



The Infinite Bandwidth Company™

MIC834

Comparator with Reference

Final Information

General Description

The MIC834 is a micropower, precision voltage comparator with an on-chip voltage reference.

The threshold is adjusted by the choice of two external resistors. Voltage detection threshold is accurate to 1.5%.

Supply current is extremely low (1.5µA, typical), making it ideal for portable applications.

The MIC834 is supplied in Micrel's IttyBitty™ 5-lead SOT-23-5 package.

Features

- Optimized for PDAs, cellular telephones, pagers, and other battery-powered devices
- Input and output can be pulled up to 6V regardless of supply voltage
- High ±1.5% voltage threshold accuracy
- Built in hysteresis for noise suppression
- Extremely low 1.5µA typical supply current
- Immune to brief input transients
- 5-lead SOT-23 package

Applications

- PDAs
- Pagers
- Cordless phones
- Consumer electronics
- Embedded controllers
- Personal electronics

Ordering Information

Part Number	Marking	Accuracy	Temperature Range	Package
MIC834BM5	B12	1.5%	-40°C to +85°C	SOT-23-5

Typical Application

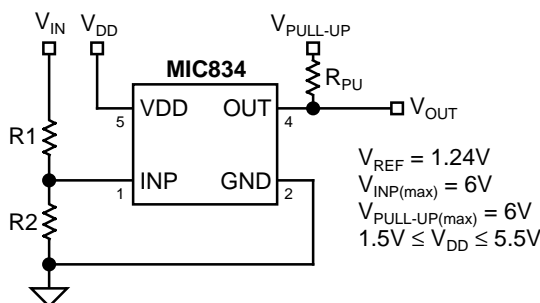

Pin Configuration

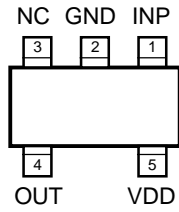

SOT-23-5 (M5)

Pin Description

Pin Number	Pin Name	Pin Function
1	INP	Input: Analog input to the comparator. When $V_{INP} > V_{REF} + V_{HYST}$, V_{OUT} is asserted to a logic-high level output.
2	GND	Ground
3	NC	No Connect
4	OUT	Output: Active-high, open-drain output. This output is de-asserted when $V_{INP} < V_{REF}$, indicating a low voltage input. The output is asserted when $V_{INP} > V_{REF} + V_{HYST}$.
5	VDD	Power Supply (Input): Independent supply input for internal circuitry.

Absolute Maximum Ratings (Note 1)

Supply Voltage (V_{DD})	-0.3V to +7V
Input Voltage (V_{INP})	+7V
Output Current (I_{OUT})	20mA
Storage Temperature (T_S)	-65°C to +150°C
ESD Rating, Note 3	2kV

Operating Ratings (Note 2)

Supply Voltage (V_{DD})	+1.5V to +5.5V
Input Voltage (V_{INP})	-0.3V to 6V
Ambient Temperature Range (T_A)	-40°C to +85°C
Junction Temperature (T_J)	Internally Limited
Package Thermal Resistance (θ_{JA})	260°C/W

Electrical Characteristics

1.5V $\leq V_{DD} \leq$ 5.5V; $T_A = +25^\circ\text{C}$, **bold** values indicate $-40^\circ\text{C} \leq T_A \leq +85^\circ\text{C}$; unless noted

Symbol	Parameter	Condition	Min	Typ	Max	Units
I_{DD}	Supply Current	output not asserted		1.5	3	μA
I_{INP}	Input Leakage Current			0.005	10	nA
V_{REF}	Reference Voltage		1.221	1.240	1.259	V
V_{HYST}	Hysteresis Voltage, Note 4		10	23	35	mV
t_D	Propagation Delay	$V_{INP} = 1.352\text{V to } 1.128\text{V}$		12		μs
		$V_{INP} = 1.143\text{V to } 1.367\text{V}$		8		μs
V_{OUT}	Output Voltage-Low, Note 5	OUT de-asserted, $I_{SINK} = 1.6\text{mA}$, $V_{DD} \geq 1.6\text{V}$		0.05	0.3	V
		OUT de-asserted, $I_{SINK} = 100\mu\text{A}$, $V_{DD} \geq 1.2\text{V}$,		0.005	0.4	V

Note 1. Exceeding the absolute maximum rating may damage the device.

Note 2. The device is not guaranteed to function outside its operating rating.

Note 3. Devices are ESD sensitive. Handling precautions recommended. Human body model, 1.5k in series with 100pF.

Note 4. $V_{HTH} = V_{REF} + V_{HYST}$.

Note 5. V_{DD} operating range is 1.5V to 5.5V. Output is guaranteed to be held low down to $V_{DD} = 1.2\text{V}$.

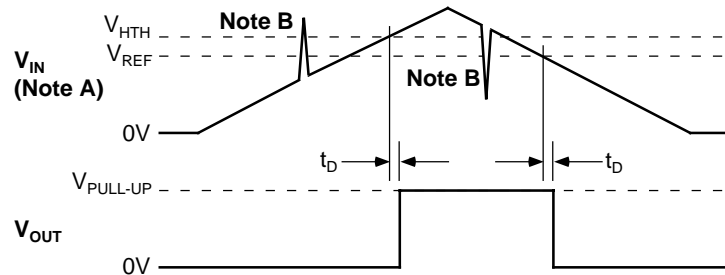
Functional Diagram

Note A. V_{IN} here represents the attenuated input voltage, as applied to the INP pin; i.e., V_{INP} .

Note B. Brief transients are ignored by the MIC834. See "Applications Information."

Block Diagram

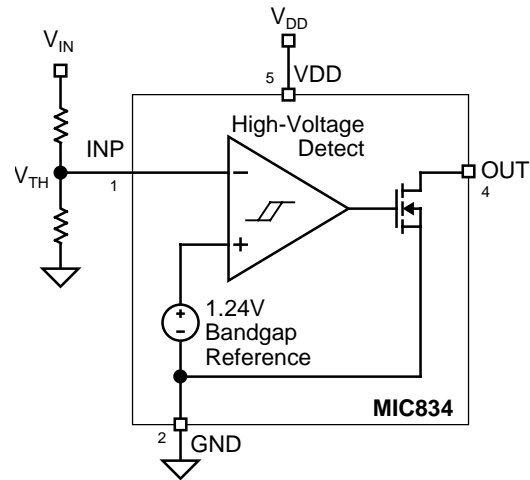

Functional Description

The MIC834 monitors the input voltage and detects when it is higher than a programmed level (plus V_{HYST}). This condition asserts the active-high output. An external pull-up resistor is used to produce a logic-one output. When the input voltage falls below the programmed threshold ($V_{\text{INP}} < V_{\text{REF}}$), the output stage is on.

Voltage Low Output

The voltage-low output (OUT) is an active-high, open-drain output which sinks current when the MIC834 detects a low input voltage.

Trip Points

Input voltage is monitored by a comparator via a voltage divider network. The divided voltage is compared to an internal reference voltage. When the voltage at the input pin INP exceeds the internal reference voltage (plus V_{HYST}), the output is pulled high by an external resistor.

V_{HYST} is typically 23mV, and is added to the programmed threshold voltage for positive-going inputs. Decreasing inputs trip at the user-programmed threshold voltage.

The tolerance of the switching threshold on the falling edge is equal to the tolerance of just the voltage reference. The tolerance of the switching threshold on the rising edge is equal to the tolerance of the voltage reference *plus* the tolerance of the hysteresis voltage.

Applications Information

Output

Since the MIC834 output is an open-drain MOSFET, most applications will require a pull-up resistor. The value of the resistor should not be too large or leakage effects may dominate. 470k Ω is the maximum recommended value. Note that the output may be pulled up as high as 6V regardless of the IC's supply voltage. See "Electrical Characteristics."

Programming the Threshold

The voltage threshold is calculated using:

$$V_{IN(lo)} = V_{REF} \left(\frac{R1+R2}{R2} \right)$$

where:

$$V_{REF} = 1.240V$$

In order to provide the additional criteria needed to solve for the resistor values, the resistors can be selected such that they have a given total value, that is, $R1 + R2 = R_{TOTAL}$. A value such as 1M Ω for R_{TOTAL} is a reasonable value because it draws minimum current but has no significant effect on accuracy.

When working with large resistors, a small amount of leakage current can cause voltage offsets that degrade system accuracy. The maximum recommended total resistance from V_{IN} to ground is 3M Ω . The accuracy of the resistors can be chosen based upon the accuracy required by the system. The inputs may be subjected to voltages as high as 6V steady-state without adverse effects of any kind regardless of the IC's supply voltage. This applies even if the supply voltage is zero. This permits the situation in which the IC's supply is turned off, but voltage is still present on the inputs. See "Electrical Characteristics."

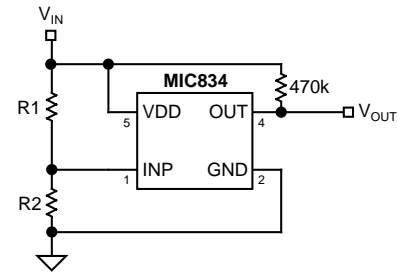

Figure 1. Example Circuit

Input Transients

The MIC834 is inherently immune to very short negative-going "glitches." Very brief transients may exceed the $V_{IN(lo)}$ threshold without tripping the output.

As shown in Figure 2, the narrower the transient, the deeper the threshold overdrive that will be ignored by the MIC834. The graph represents the typical allowable transient duration for a given amount of threshold overdrive that will not generate an output.

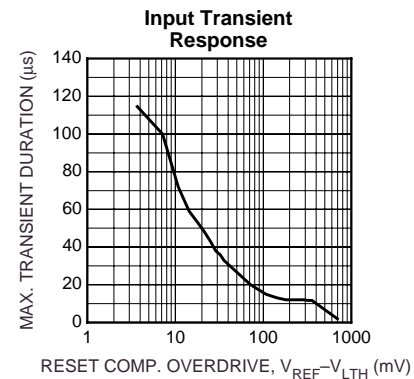
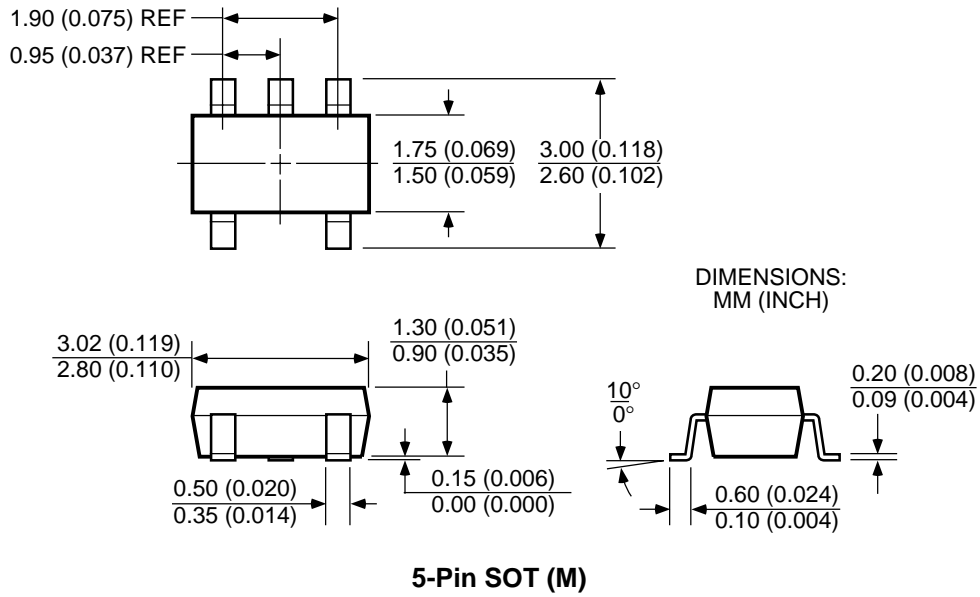

Figure 2. Input Transient Response

Package Information



MICREL INC. 1849 FORTUNE DRIVE SAN JOSE, CA 95131 USA

TEL + 1 (408) 944-0800 FAX + 1 (408) 944-0970 WEB <http://www.micrel.com>

This information is believed to be accurate and reliable, however no responsibility is assumed by Micrel for its use nor for any infringement of patents or other rights of third parties resulting from its use. No license is granted by implication or otherwise under any patent or patent right of Micrel Inc.

© 2001 Micrel Incorporated

X-ON Electronics

Largest Supplier of Electrical and Electronic Components

Click to view similar products for [Analog Comparators](#) category:

Click to view products by [Microchip](#) manufacturer:

Other Similar products are found below :

[SC2903VDR2G](#) [LM2901SNG](#) [LM339SNG](#) [55122](#) [5962-8757203IA](#) [NTE911](#) [5962-8751601DA](#) [LM339EDR2G](#) [NTE922](#) [SC2901DR2G](#)
[LM2903M/TR](#) [LM2903F-E2](#) [MCP6544-EP](#) [LM2901EDR2G](#) [TS391SN2T1G](#) [LM111JG](#) [LM239APT](#) [5962-8765801PA](#) [LT6700HVIS6-](#)
[2#TRMPBF](#) [5962-8765902CA](#) [ADCMP394ARZ-RL7](#) [LM339AMX](#) [AZV331KSTR-G1](#) [LT1716IS5#TRMPBF](#) [LTC1440CN8#PBF](#)
[LTC1542CS8#PBF](#) [LTC1445CS#PBF](#) [TL331VSN4T3G](#) [LT6700IDCB-1#TRMPBF](#) [LTC1042CN8#PBF](#) [LTC1540CMS8#PBF](#) [LT6703CDC-](#)
[2#TRMPBF](#) [ADCMP607BCPZ-R7](#) [LT1720CDD#PBF](#) [LTC1040CN#PBF](#) [LT6700MPDCB-1#TRMPBF](#) [LT6700IDCB-3#TRMPBF](#)
[LM2903WHYST](#) [TLV1701AIDRLR](#) [S-89431ACNC-HBVTFG](#) [LT1018CS8#PBF](#) [NTE1718](#) [NTE943](#) [NTE943M](#) [NTE943SM](#)
[TA75S393F,LF\(T](#) [ALD2301APAL](#) [ALD2302APAL](#) [TSX3704IYPT](#) [AD790JNZ](#)