



# 3A High-Side Load Switch with Reverse Blocking

## MIC94161/2/3/4/5 Evaluation Board

### General Description

The MIC94161/2/3/4/5 is a family of high-side load switches designed to operate from 1.7V to 5.5V input voltage. The load switch pass element is an internal 14.5mΩ  $R_{DS(ON)}$  N-Channel MOSFET which enables the device to support up to 3A of continuous current. Additionally, the load switch supports 1.5V logic level control and shutdown features in a tiny 1.5mm × 1mm 6-ball WLCSP package.

The MIC9416x provides reverse current protection when the device is disabled. The device will not allow the flow of current from the output to the input when the device is turned OFF. Additionally, the MIC94161 features overvoltage protection to protect the load when the input voltage is above 4.55V, as well as a precise enable threshold which keeps the MIC94161 in the default OFF state until the EN pin rises above 1.15V.

An input capacitor may be required when the power supply is more than 4-inches away from the device. The evaluation board includes an input capacitor of 10μF to compensate for long inductive test leads.

Datasheets and support documentation are available on Micrel's web site at: [www.micrel.com](http://www.micrel.com).

### Requirements

The MIC94161/2/3/4/5 evaluation board requires an input power source that is able to deliver at least 3A at a voltage within the range of 1.7V to 5.5V. The output load can be either active or passive.

### Precautions

The evaluation board does not have reverse polarity protection. Applying a negative voltage to the  $V_{IN}$  terminal may damage the device.

The evaluation board is tailored for a Li-Ion range input supply voltage. It should not exceed 5.5V on the input.

### Getting Started

#### 1. Connect an external supply to $V_{IN}$ .

Apply the desired input voltage to the  $V_{IN}$  (J3) and ground terminal (J6) of the evaluation board, paying careful attention to polarity and supply voltage ( $1.7V \leq V_{IN} \leq 5.5V$ ). An ammeter may be placed between the input supply and the  $V_{IN}$  terminal to the evaluation board to accurately monitor the input current. The ammeter and power lead resistance can reduce the voltage supplied to the input so monitor the supply voltage at the  $V_{IN}$  terminal.

#### 2. Enable/Disable the MIC94161/2/3/4/5.

The MIC9416x family of high side switches, have an internal 2MΩ pull down resistor to GND on the enable pin to disable the device when an enable signal is not present. To enable an output simply jumper the EN terminal (J5) to  $V_{IN}$  (J3) or apply an Active-high CMOS compatible logic to (J3).

#### 3. Connect the load to the $V_{OUT}$ terminal (J4) and ground terminal (J7).

The load can be either a passive (resistor) or active (electronic load). Be sure to monitor the output voltage at the  $V_{OUT}$  (J4) terminals.

### Ordering Information

Part Number	Description
MIC94161YCS EVB	Evaluation board with 3A High-Side switch, 2.7ms turn on, and OVP.
MIC94162YCS EVB	Evaluation board with 3A High-Side switch, 60μs turn on, and auto discharge.
MIC94163YCS EVB	Evaluation board with 3A High-Side switch and 60μs turn on.
MIC94164YCS EVB	Evaluation board with 3A High-Side switch, 2.7ms turn on, and auto discharge.
MIC94165YCS EVB	Evaluation board with 3A High-Side switch and 2.7ms turn on.

## Evaluation Board Schematic

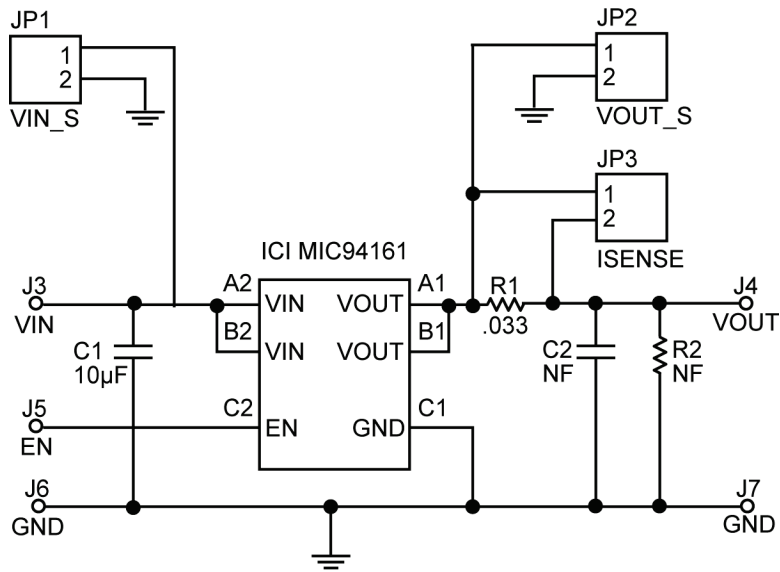

## Bill of Materials

Item	Part Number	Manufacturer	Description	Qty
C1	C1608X5R0J106M	TDK <sup>(1)</sup>	Capacitor, 10µF Ceramic, 6.3V, X5R, Size 0603	1
R3	ERJ-8BWFR033V	Panasonic <sup>(2)</sup>	Resistor, 0.033Ω, 1W, Size 1206	1
U1	<b>MIC9416xYCS</b>	<b>Micrel<sup>(3)</sup></b>	<b>3A High-Side Load Switch with Reverse Blocking</b>	<b>1</b>

**Notes:**

1. TDK: [www.tdk.com](http://www.tdk.com)
2. Panasonic: [www.panasonic.com](http://www.panasonic.com)
3. Micrel: [www.micrel.com](http://www.micrel.com)

### PCB Layout Recommendations

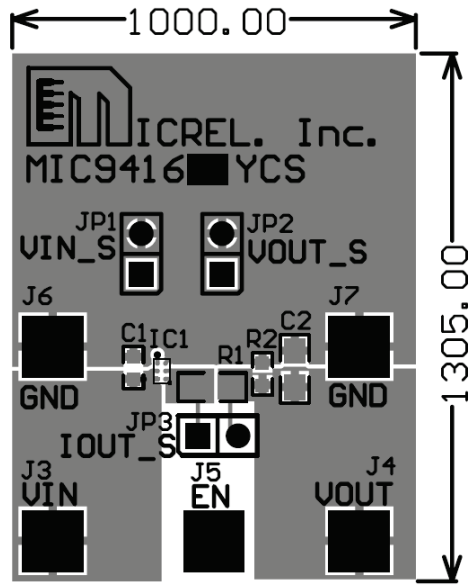

Top Layer

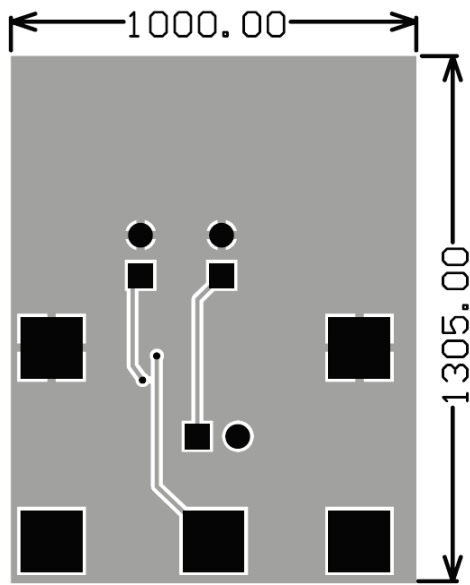

Bottom Layer

---

**MICREL, INC. 2180 FORTUNE DRIVE SAN JOSE, CA 95131 USA**  
TEL +1 (408) 944-0800 FAX +1 (408) 474-1000 WEB <http://www.micrel.com>

Micrel makes no representations or warranties with respect to the accuracy or completeness of the information furnished in this data sheet. This information is not intended as a warranty and Micrel does not assume responsibility for its use. Micrel reserves the right to change circuitry, specifications and descriptions at any time without notice. No license, whether express, implied, arising by estoppel or otherwise, to any intellectual property rights is granted by this document. Except as provided in Micrel's terms and conditions of sale for such products, Micrel assumes no liability whatsoever, and Micrel disclaims any express or implied warranty relating to the sale and/or use of Micrel products including liability or warranties relating to fitness for a particular purpose, merchantability, or infringement of any patent, copyright or other intellectual property right.

Micrel Products are not designed or authorized for use as components in life support appliances, devices or systems where malfunction of a product can reasonably be expected to result in personal injury. Life support devices or systems are devices or systems that (a) are intended for surgical implant into the body or (b) support or sustain life, and whose failure to perform can be reasonably expected to result in a significant injury to the user. A Purchaser's use or sale of Micrel Products for use in life support appliances, devices or systems is a Purchaser's own risk and Purchaser agrees to fully indemnify Micrel for any damages resulting from such use or sale.

© 2013 Micrel, Incorporated.

## X-ON Electronics

Largest Supplier of Electrical and Electronic Components

*Click to view similar products for [Power Management IC Development Tools](#) category:*

*Click to view products by [Microchip](#) manufacturer:*

Other Similar products are found below :

[EVAL6482H-DISC](#) [EVAL-AD5522EBUZ](#) [EVAL-ADM1060EBZ](#) [EVAL-ADM1073MEBZ](#) [EVAL-ADM1166TQEBZ](#) [EVAL-ADM1168LQEBZ](#) [EVAL-ADM1171EBZ](#) [EVAL-ADM1276EBZ](#) [EVB-EN5319QI](#) [EVB-EN5365QI](#) [EVB-EN6347QI](#) [EVB-EP5348UI](#) [MIC23158YML EV](#) [MIC23451-AAAYFL EV](#) [MIC5281YMME EV](#) [124352-HMC860LP3E](#) [ADM00513](#) [ADM8611-EVALZ](#) [ADM8612-EVALZ](#) [ADM8613-EVALZ](#) [ADP1046ADC1-EVALZ](#) [ADP1055-EVALZ](#) [ADP122-3.3-EVALZ](#) [ADP130-0.8-EVALZ](#) [ADP130-1.2-EVALZ](#) [ADP130-1.5-EVALZ](#) [ADP130-1.8-EVALZ](#) [ADP160UJZ-REDYKIT](#) [ADP166UJ-EVALZ](#) [ADP1712-3.3-EVALZ](#) [ADP1714-3.3-EVALZ](#) [ADP1715-3.3-EVALZ](#) [ADP1716-2.5-EVALZ](#) [ADP1740-1.5-EVALZ](#) [ADP1752-1.5-EVALZ](#) [ADP1754-1.5-EVALZ](#) [ADP1828LC-EVALZ](#) [ADP1870-0.3-EVALZ](#) [ADP1871-0.6-EVALZ](#) [ADP1873-0.6-EVALZ](#) [ADP1874-0.3-EVALZ](#) [ADP1876-EVALZ](#) [ADP1879-1.0-EVALZ](#) [ADP1882-1.0-EVALZ](#) [ADP1883-0.6-EVALZ](#) [ADP197CB-EVALZ](#) [ADP199CB-EVALZ](#) [ADP2102-1.25-EVALZ](#) [ADP2102-1.2-EVALZ](#) [ADP2102-1.875EVALZ](#)