

2-20GHz, 12.5dB Gain Low-Noise Wideband Distributed Amplifier

Features

- >16.5dBm P_{1dB} with 1.9dB NF and 12.5dB gain at 10GHz
- <2dB NF from 6-12GHz
- Single supply voltage of +8V @ 50mA
- Input and Output matched to 50Ω
- 1.5mm x 2.82mm x 0.1mm die size

Applications

- Instrumentation
- Electronic warfare
- Microwave communications
- Radar

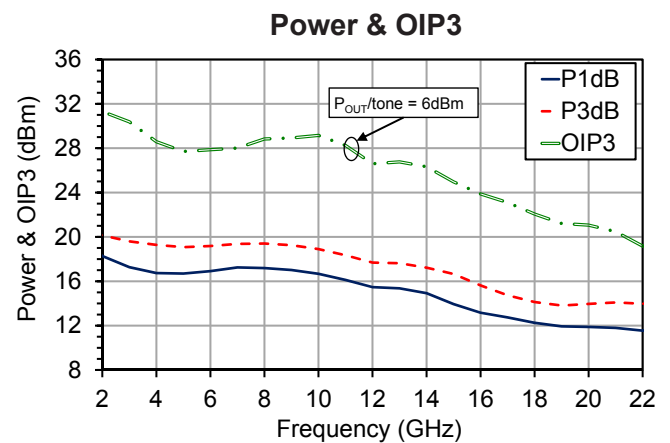
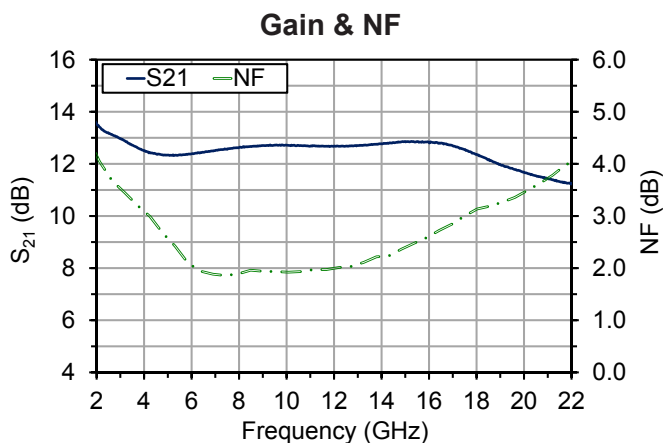
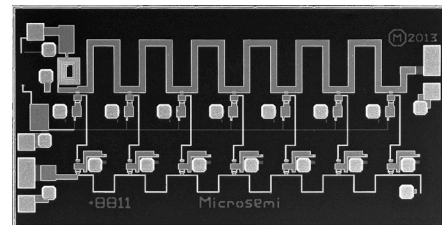

Typical Performance (CW, Typical Device, RF Probe): $T_A = 25^\circ\text{C}$, $V_{DD} = 8\text{V}$

Parameter	Min	Typ	Max	Units
Frequency	2	-	22	GHz
Small Signal Gain	11.3	-	13.5	dB
Noise Figure	1.9	2.5	4.0	dB
Output Power, P_{1dB}	12	14	18	dBm
Output Power, P_{3dB}	14	18	20	dBm
Output IP3	19	26	31	dBm
Drain Current		50		mA

Table 1: Absolute Maximum Ratings, Not Simultaneous

Parameter	Rating	Units
Drain Voltage (V_D)	+9	V
Input Power (P_{IN})	24	dBm
Channel Temperature (T_C)	150 ¹	°C
Operating Ambient Temperature (T_A)	-55 to +85	°C
Storage Temperature	-65 to +150	°C
Thermal Resistance, Channel to Die Backside	40	°C/W



Caution, ESD Sensitive Device

¹ MTTF > 10⁸ hours at $T_C = 150^\circ\text{C}$
Table 2: Specifications (CW, 100% Test): $T_A = 25^\circ\text{C}$, $V_{DD} = 8\text{V}$

Parameter		Min	Max	Units
I_{DD}	-	-	105	mA
Small Signal Gain	20GHz	9.5	-	dB
Output Power, P_{1dB}	20GHz	9.0	-	dBm

RF Probe Measurement Set-Up With Reference Planes²

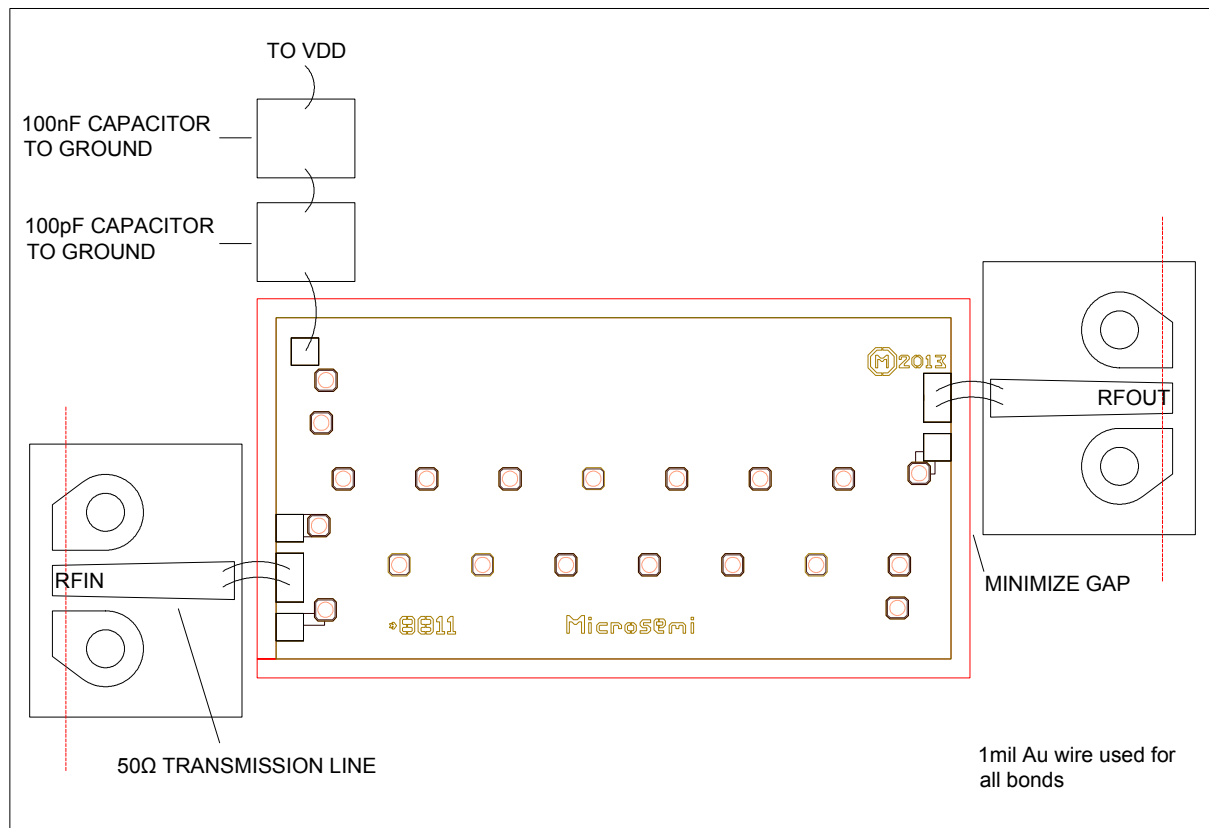
² Reference planes are the same for S-parameter files downloadable on www.microsemi.com/mmics

Typical Performance, RF Probe

$V_{DD} = 8V$, $I_{DD} = 50mA$, $T_A = 25^\circ C$ unless otherwise noted

S_{11} Over Temperature

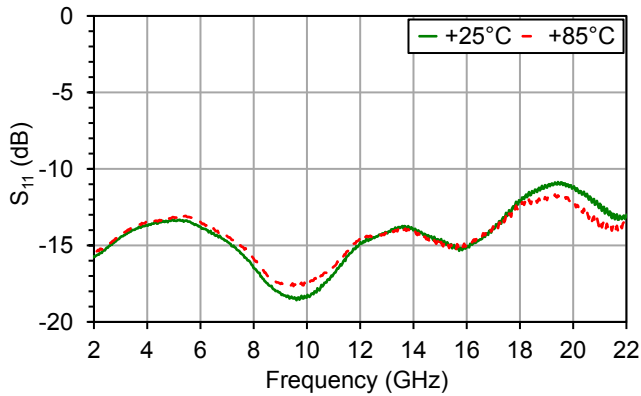

S_{22} Over Temperature

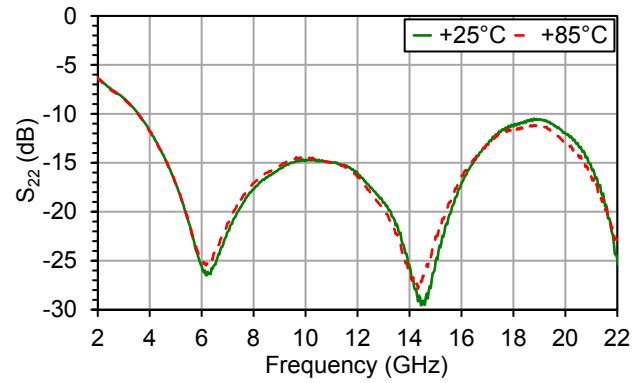

S_{21} Over Temperature

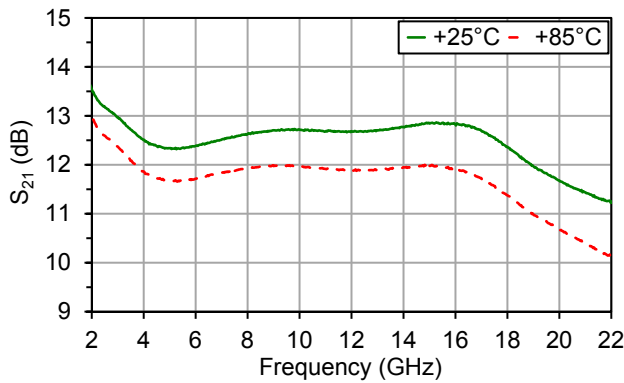

NF Over Temperature

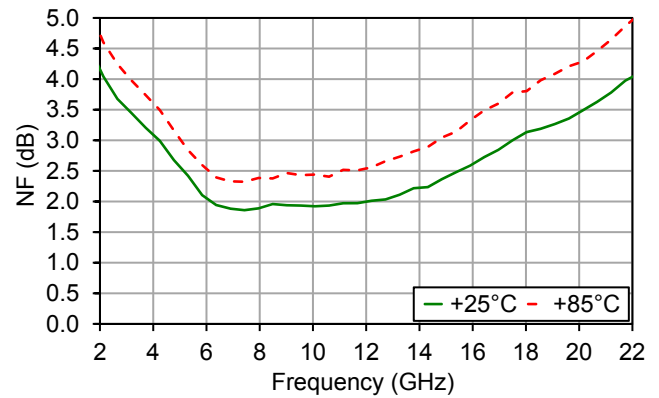

P_{1dB} Over Frequency

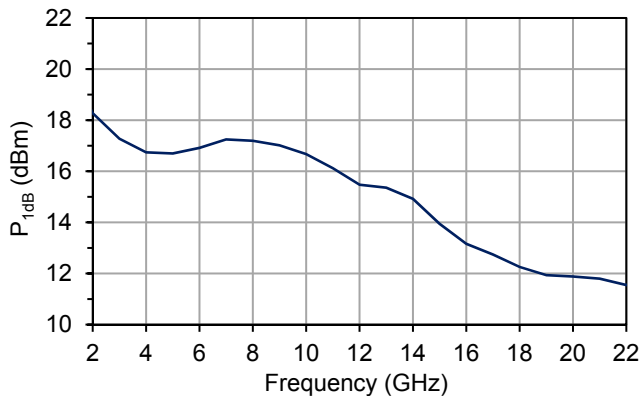

P_{3dB} Over Frequency

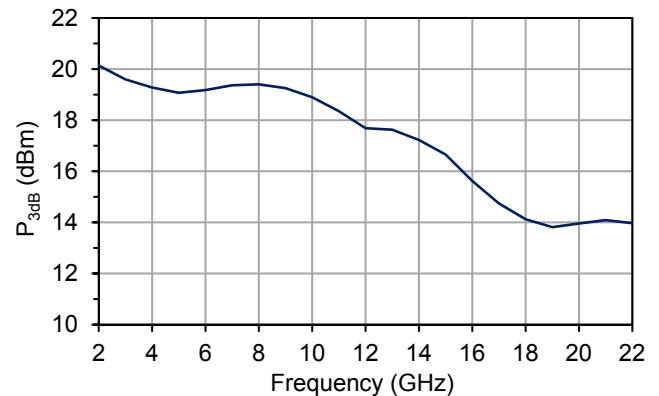

Typical Performance, RF Probe

$V_{DD} = 8V$, $I_{DD} = 50mA$, $T_A = 25^\circ C$ unless otherwise noted

OIP3 Over P_{OUT}

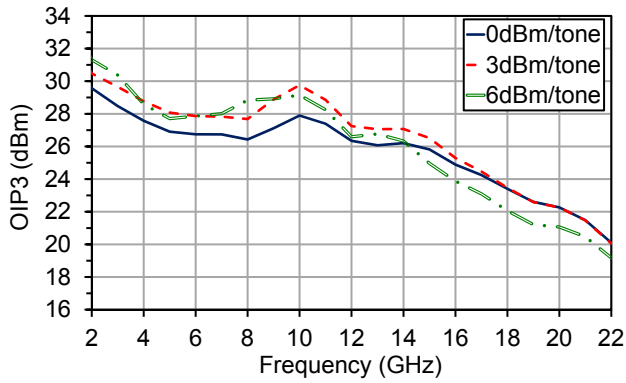

Power Sweep

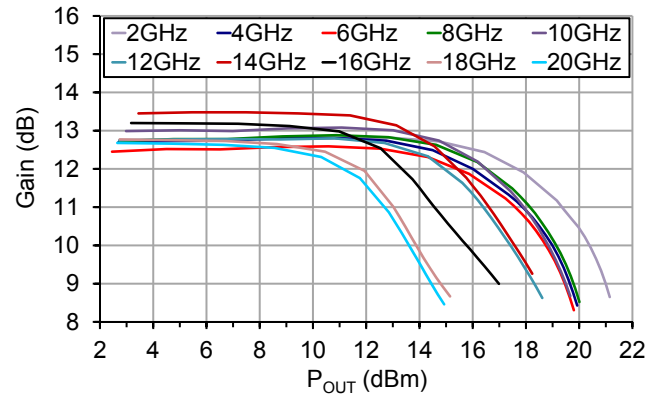

IMD3 Sweep

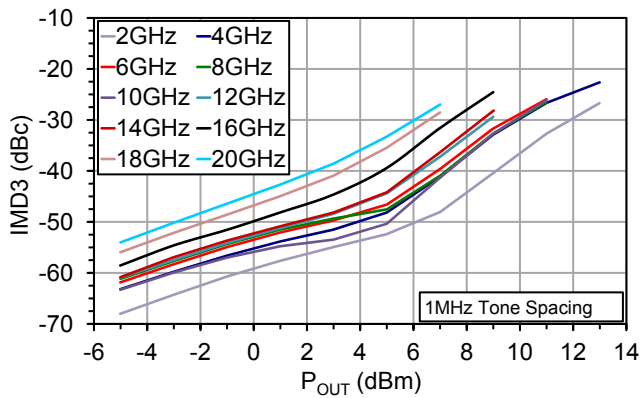

Connectorized Test Fixture

With SMK 2.92mm Connectors

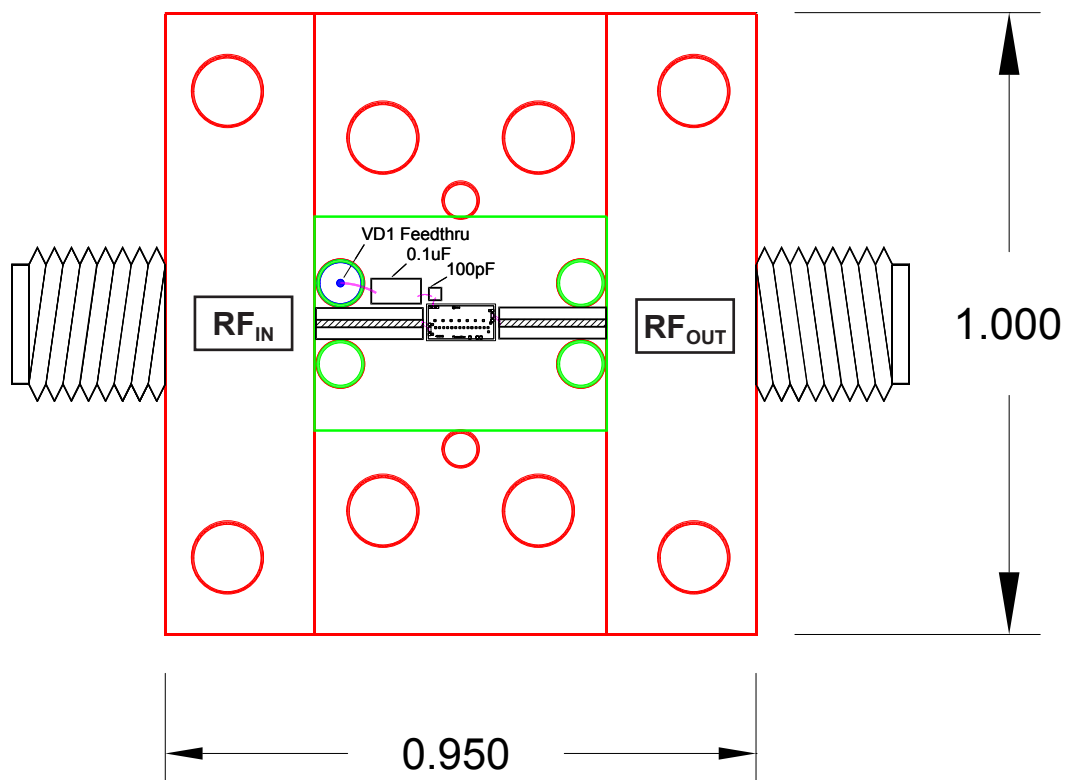

Typical Performance, Connectorized Test Fixture

$V_{DD} = 8V$, $I_{DD} = 50mA$, $T_A = 25^\circ C$ unless otherwise noted

S_{11} Over Temperature

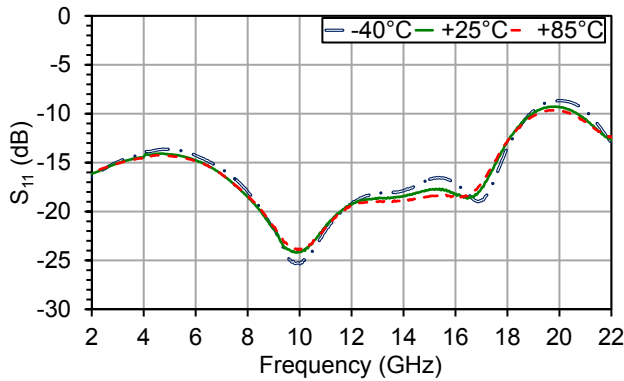

S_{22} Over Temperature

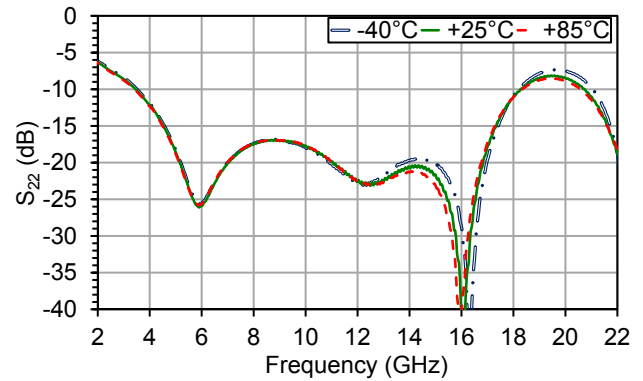

S_{21} Over Temperature

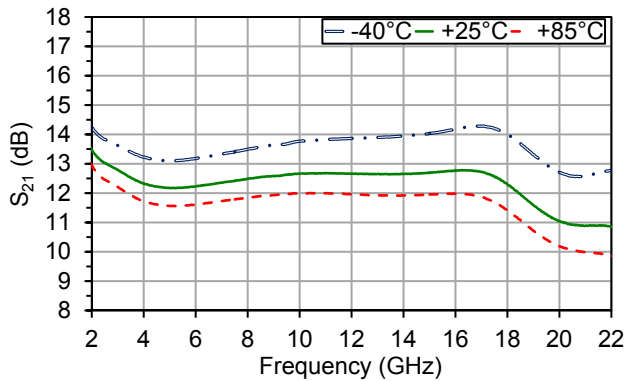

NF Over Temperature

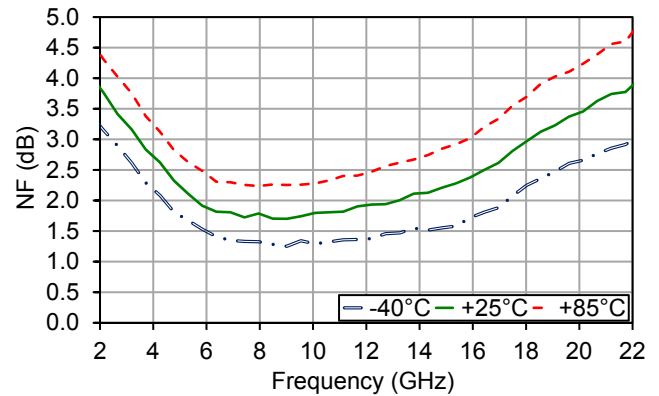

P_{1dB} Over Temperature

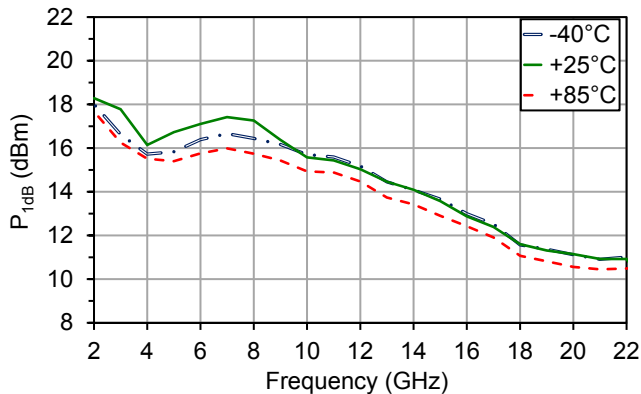

P_{3dB} Over Temperature

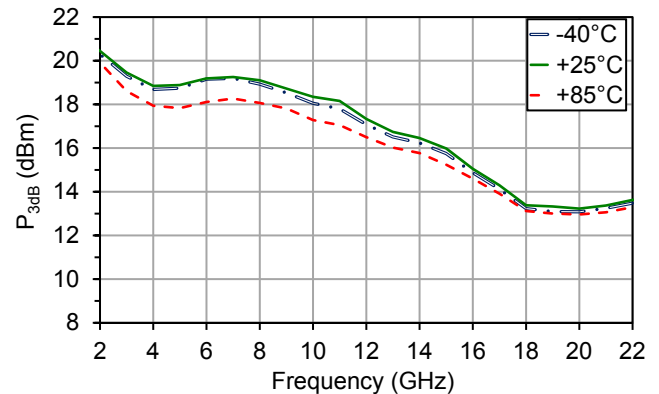

Typical Performance, Connectorized Test Fixture

$V_{DD} = 8V, I_{DD} = 50mA, T_A = 25^\circ C$ unless otherwise noted

Power Sweep, $-40^\circ C$

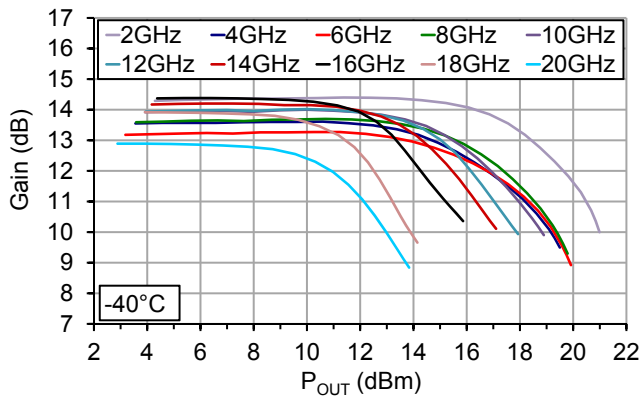

Power Sweep, $+25^\circ C$

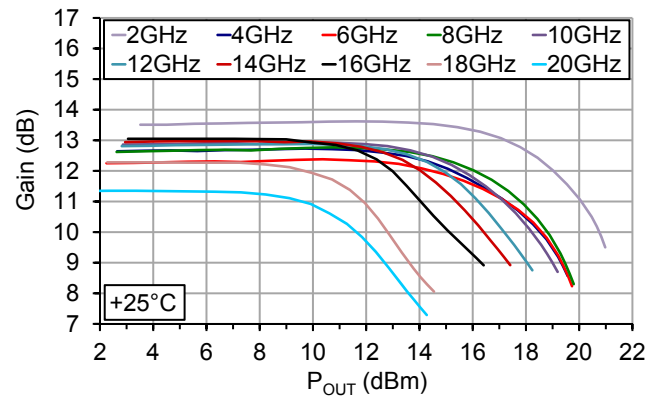

Power Sweep, $+85^\circ C$

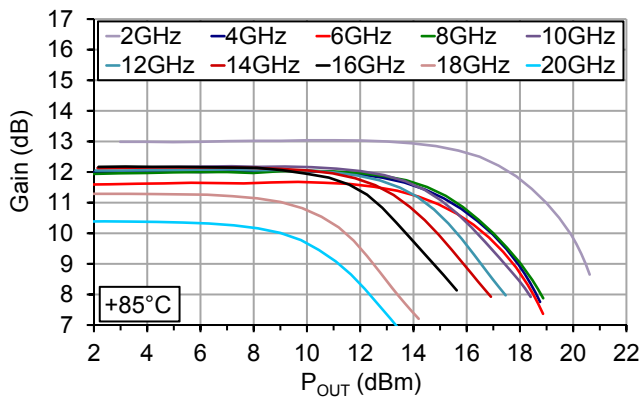

OIP3, 0dBm/tone

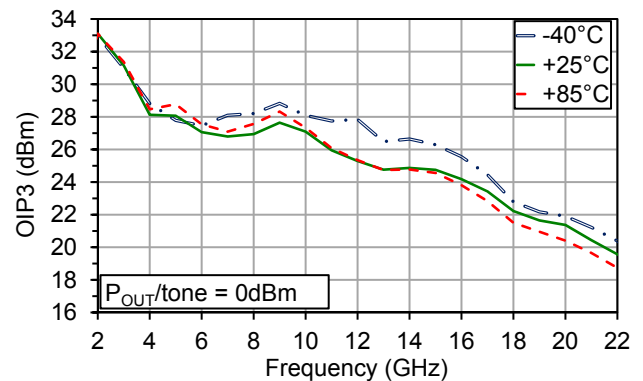

OIP3, 3dBm/tone

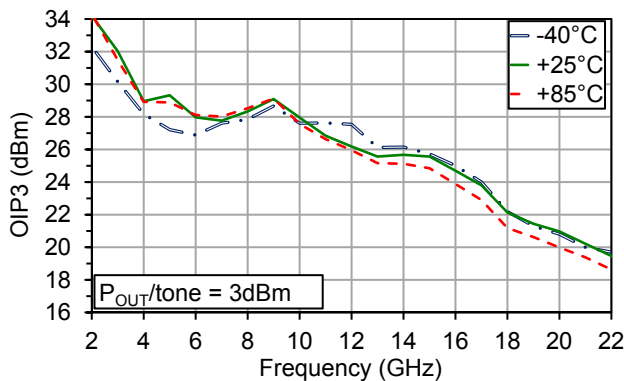

IMD3 Sweep, $-40^\circ C$

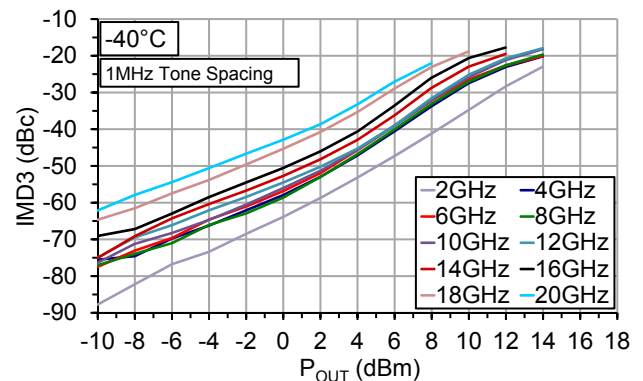

Typical Performance, Connectorized Test Fixture

$V_{DD} = 8V$, $I_{DD} = 50mA$, $T_A = 25^\circ C$ unless otherwise noted

IMD3 Sweep, +25°C, 1MHz Tone Spacing

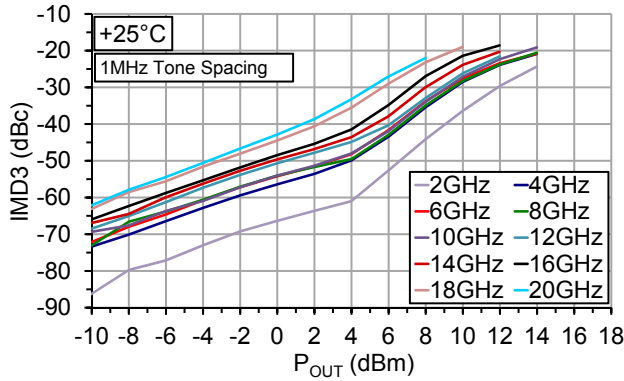

IMD3 Sweep, +85°C, 1MHz Tone Spacing

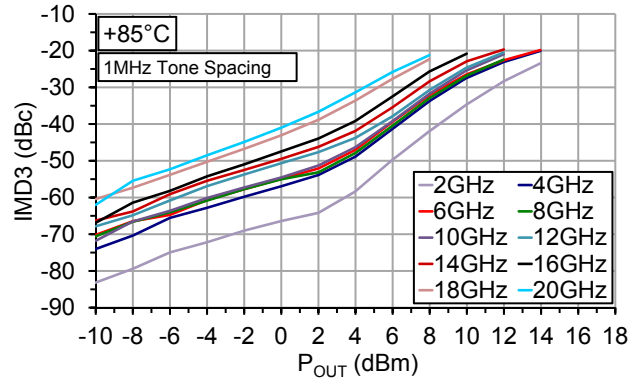

DC

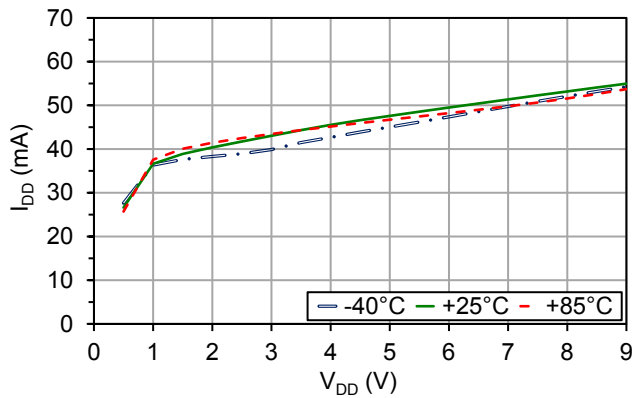

Chip layout showing pad locations.

All dimensions are in microns. Die thickness is 100 microns. Backside metal is gold, bond pad metal is gold. Refer to Die Handling Application Note MM-APP-0001 (visit www.microsemi.com/mmics).

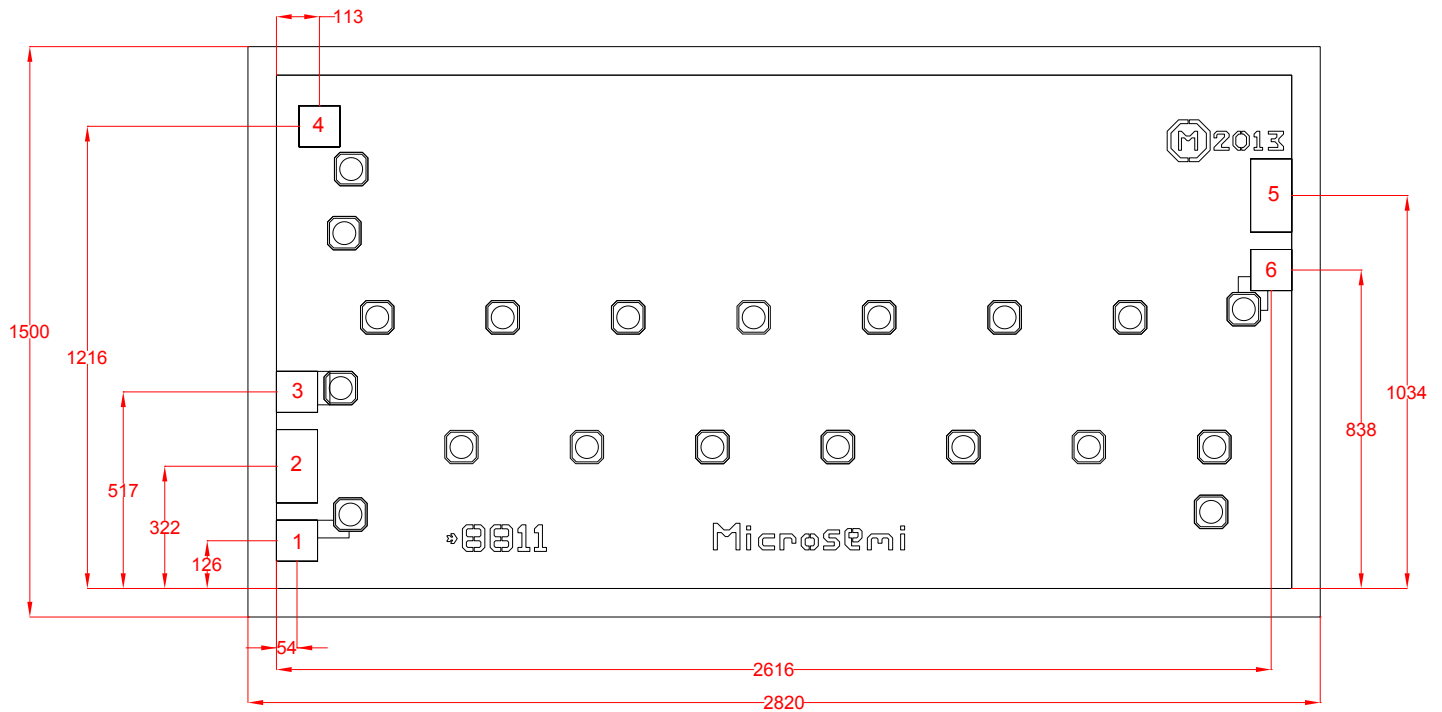
Table 3: Pad Descriptions

Pad #	Description	Pad Dimensions (μm)
1, 3, 6	Ground	100 x 100
2	RF_{IN} , AC Coupled	100 x 190
5	RF_{OUT} , AC Coupled	100 x 190
4	V_{DD}	100 x 100

Biasing

MMA003AA is a self-biased device with single positive supply. Apply V_{DD} to pad 4.

Information contained in this document is proprietary to Microsemi. This document may not be modified in any way without the express written consent of Microsemi. Product processing does not necessarily include testing of all parameters. Microsemi reserves the right to change the configuration and performance of the product and to discontinue product at any time.

Microsemi Corporate Headquarters

One Enterprise, Aliso Viejo CA 92656 USA
Within the USA: +1 (949) 380-6100
Sales: +1 (949) 380-6136
Fax: +1 (949) 215-4996

Microsemi Corporation (Nasdaq: MSCC) offers a comprehensive portfolio of semiconductor and system solutions for communications, defense and security, aerospace, and industrial markets. Products include high-performance and radiation-hardened analog mixed-signal integrated circuits, FPGAs, SoCs, and ASICs; power management products; timing and synchronization devices and precise time solutions, setting the world's standard for time; voice processing devices; RF solutions; discrete components; security technologies and scalable anti-tamper products; Power-over-Ethernet ICs and midspans; as well as custom design capabilities and services. Microsemi is headquartered in Aliso Viejo, Calif. and has approximately 3,400 employees globally. Learn more at www.microsemi.com.

© 2014 Microsemi Corporation. All rights reserved. Microsemi and the Microsemi logo are trademarks of Microsemi Corporation. All other trademarks and service marks are the property of their respective owners.

X-ON Electronics

Largest Supplier of Electrical and Electronic Components

Click to view similar products for [RF Amplifier category](#):

Click to view products by [Microchip manufacturer](#):

Other Similar products are found below :

[A82-1](#) [BGA622H6820XTSA1](#) [BGA 728L7 E6327](#) [BGB719N7ESDE6327XTMA1](#) [HMC397-SX](#) [HMC405](#) [HMC561-SX](#) [HMC8120-SX](#)
[HMC8121-SX](#) [HMC-ALH382-SX](#) [HMC-ALH476-SX](#) [SE2433T-R](#) [SMA3101-TL-E](#) [SMA39](#) [A66-1](#) [A66-3](#) [A67-1](#) [LX5535LQ](#) [LX5540LL](#)
[MAAM02350](#) [HMC3653LP3BETR](#) [HMC549MS8GETR](#) [HMC-ALH435-SX](#) [SMA101](#) [SMA32](#) [SMA411](#) [SMA531](#) [SST12LP17E-XX8E](#)
[SST12LP19E-QX6E](#) [WPM0510A](#) [HMC5929LS6TR](#) [HMC5879LS7TR](#) [HMC1126](#) [HMC1087F10](#) [HMC1086](#) [HMC1016](#) [SMA1212](#)
[MAX2689EWS+T](#) [MAAMSS0041TR](#) [MAAM37000-A1G](#) [LTC6430AIUF-15#PBF](#) [CHA5115-QDG](#) [SMA70-2](#) [SMA4011](#) [A231](#) [HMC-](#)
[AUH232](#) [LX5511LQ](#) [LX5511LQ-TR](#) [HMC7441-SX](#) [HMC-ALH310](#)