

# Atmel LED Driver-MSL1060

6-string PWM LED Driver with Digitally Compensated, 1.1MHz, 48V Boost Regulator and  $\pm 1.5\%$  LED String Current Balance

Datasheet



# Atmel LED Driver-MSL 1060

6-string PWM LED Driver with Digitally Compensated, 1.1MHz, 48V Boost Regulator and  $\pm 1.5\%$  LED String Current Balance

## General Description

The Atmel® LED Driver-MSL 1060 is an LED driver with integrated boost regulator capable of driving 6 LED strings at 30mA up to 48V for lighting applications to 8W. In a typical backlighting system it can drive up to 72 white LEDs.

The MSL 1060 incorporates a current mode PWM boost regulator with 50V internal switch and a wide, 4.75V to 36V input voltage range. The 1.1MHz switching frequency uses a small-sized inductor and output capacitors while maintaining high efficiency, low ripple, and noise.

The MSL 1060 uses a digital control loop and requires no external components to manage the LED supply and regulate LED current up to 30mA per series LED string.

The MSL 1060 is also easy to use, dimming with an external PWM signal.

Analog dimming of LED string current is available for use with an ambient light sensor (ALS) and/or temperature management with a thermistor or IC temperature sensor.

The MSL 1060 is offered in a lead-free, halogen-free, RoHS-compliant, 5 x 5mm, 24-lead TQFN package operating over a -40°C to 85°C temperature range.

## Applications

### Long Life, Efficient LED Backlighting for:

- Notebook PCs and Desktop PC Monitors
- Medical and Industrial Instrumentation
- Portable Media Players (PMPs)
- Automotive Audio-visual Displays

### Industrial Lighting

### Signage

## Ordering Information

PART	DESCRIPTION	PACKAGE
MSL1060AW	6-ch LED driver	24-pin, 5x5x0.75mm TQFN

# Atmel LED Driver-MSL 1060

6-string PWM LED Driver with Digitally Compensated, 1.1MHz, 48V Boost Regulator and  $\pm 1.5\%$  LED String Current Balance

## Key Features

- Drives 6 Strings of up to 12 LEDs per String
- Drives 72 White LEDs at 30mA for 8W Power
- Better than  $\pm 1.5\%$  String Current Accuracy
- 4.75V to 36V Wide Input Supply Range
- Boost Regulator with 50V Internal Switch
- 1.1MHz Current Mode PWM Boost
- Up to 92% Boost Regulator Efficiency
- Internal, Automatic Power Supply Management
- Adjustable LED Current up to 30mA Per String
- String Outputs can be Paralleled in Any Combination to Drive  $>30\text{mA}$  LEDs
- ALS Interface for Automatic Brightness Setting
- Temperature Sensor Interface for Temp Derating
- Individual O/C and S/C String Fault Detection
- Faulty Strings are Automatically Disabled
- FLTB Logic Output Reports Faults
- Enable Input Allows Logic On/Off Control
- PWM Input Provides Wide Dimming Range
- Adjustable Over-voltage Protection
- $-40^{\circ}\text{C}$  -  $+85^{\circ}\text{C}$  Operating Temperature Range
- Lead-free, Halogen-free, RoHS-compliant

## Application Circuit

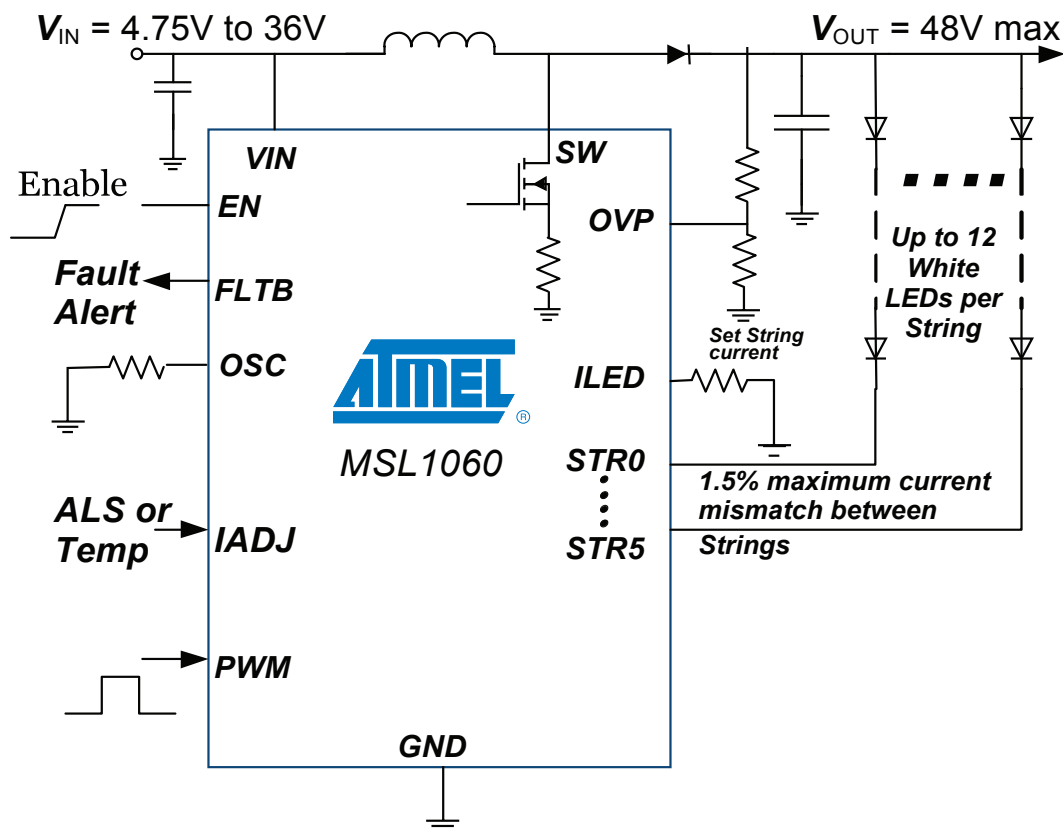



## Table of Contents

<b>Quick Start Guide</b> .....	<b>5</b>
How Many LEDs Can Be Driven by the MSL 1060/61/64.....	5
Differences between MSL 1060, MSL 1061 and MSL 1064.....	5
Capabilities With and Without Using the Serial Interface.....	6
<b>Packages and Connections</b> .....	<b>7</b>
MSL 1060 - 24 Lead, 5mm x 5mm x 0.75mm TQFN Package with 0.65mm Lead Pitch.....	7
<b>Connection Description</b> .....	<b>8</b>
<b>Absolute Maximum Rating</b> .....	<b>9</b>
<b>Electrical Characteristics</b> .....	<b>10</b>
<b>Typical Operating Characteristics</b> .....	<b>12</b>
<b>Typical Operating Characteristics (Continued)</b> .....	<b>13</b>
<b>Block Diagram</b> .....	<b>14</b>
<b>Typical Application Circuit</b> .....	<b>15</b>
<b>Detailed Description</b> .....	<b>16</b>
LED Current Sinks.....	16
PWM Brightness Control.....	16
Boost Regulator.....	17
Fault Management.....	17
<b>Application Information</b> .....	<b>18</b>
VCC and VDD Regulators.....	18
Internal Oscillator - R4.....	18
Setting the Full-scale LED String Current - R5.....	18
Enable Input - R7.....	18
IADJ Input - LED Temperature Compensation and/or Ambient Light Sensing.....	19
Boost Regulator Components.....	19
Over-voltage Protection (OVP) - R8 and R9.....	19

# Atmel LED Driver-MSL 1060

6-string PWM LED Driver with Digitally Compensated, 1.1MHz, 48V Boost Regulator and  $\pm 1.5\%$  LED String Current Balance

## Quick Start Guide

This section summarizes the capabilities of, and differences between, the MSL 1060 and the similar Atmel MSL 1061 and Atmel MSL 1064 with I<sup>2</sup>C interfaces.

The MSL 1060 and MSL 1061/64 are LED string drivers with integrated boost regulators, which power, monitor, and dim multiple LEDs at high efficiency for backlighting and signage applications. Each MSL 1060/61/64 contains six outputs, each capable of sinking up to 30mA through a string of series-connected LEDs dropping up to 45V; 8W of lighting power.

### How Many LEDs Can the Atmel LED Drivers-MSL 1060/61/64 Drive?

The MSL 1060/61/64 includes six current sinks (STR0 through STR5) that each control the LED current of multiple, series-connected, white LEDs. Any combination of the six strings may be enabled, and not all the strings need to be used.

It is important that each enabled string contain the same number of the same type of LED so that the total voltage drop for each string is the same. This is necessary because there is only one boost regulator (and, therefore, only one LED supply) available to serve all six strings. Use a single MSL 1060/61/64 to drive multiple LEDs of a single color/chemistry, such as white LED backlighting or single-color signage. For multicolor applications (e.g. RG, RGB, RGGB, RGBA), use a separate MSL 1060/61/64 per LED color/chemistry type. Each MSL 1060/61/64 manages its integrated boost regulator to optimize efficiency for its strings of identical LEDs with matched electrical characteristics.

The 48V maximum voltage rating of the boost regulator's internal power FET determines the maximum number of LEDs allowed in a string. The overvoltage protection (OVP) circuit protects the FET as well as external components. The accuracy of the OVP threshold is 2% plus another 1% for the external setting resistors, R8 and R9 (Figure 16 on page 15) reducing the operating maximum voltage to 46.5V. The total voltage needed to drive a string is the forward voltage drop across the desired LED strings, plus the 600mV headroom needed the string's output current sink (600mV) to keep it in regulation. Since the FET voltage is higher than the boost voltage by the rectifier forward voltage drop, the available voltage for LEDs is approximately 46.5V - 0.6V - 0.9V or 45V. Thus the MSL 1060 can drive up to 12 series LEDs as long as the LED forward voltage is less than 3.75V.

### Differences Between Atmel LED Drivers-MSL 1060, MSL 1061 and MSL 1064

Use the MSL 1061 in applications where one or more LED drivers are directly controlled by a PWM input signal. The PWM input signal globally controls the LED dimming. Use the MSL 1061/64 for applications where the LED drivers communicate by an I<sup>2</sup>C/SMB interface. The MSL 1064 has a single slave address, while the MSL 1061 has four available addresses which allows communication to all four LED drivers on the same I<sup>2</sup>C interface (Table 1).



**Table 1. Atmel LED Drivers-MSL1060, MSL1061, and MSL1064 Comparison**

FEATURE	MSL1060	MSL1064	MSL1061
I <sup>2</sup> C interface	Not available	1 fixed slave address (0x62)	4 selectable slave addresses by AD0 (0x60, 0x61, 0x62, 0x63)
Package	24-lead, 5mm x 5mm TQFN, 0.65mm pitch		28-lead, 5mm x 5mm TQFN, 0.5mm pitch

### Capabilities With and Without Using the Serial Interface

The MSL1060/61/64 operates as standalone LED drivers with full digital (PWM) and analog (DAC) LED dimming control and fault reporting. For the MSL1061/64, these functions are managed over the I<sup>2</sup>C or SMB serial interface. This allows LED intensity control through software. The serial interface also accesses more detailed fault management reporting as well as software controlled shutdown which turns off the LED drivers while the serial interface remains active.

**Table 2. Atmel LED Drivers-MSL1061/64 Standalone Capabilities Changes I<sup>2</sup>C Controlled Features**

FUNCTION	CONTROLS AVAILABLE BY HARDWARE INPUTS (SEE TABLE 3 ON PAGE 8)	ADDITIONAL CONTROLS AVAILABLE VIA I <sup>2</sup> C (SEE MSL1061/64 DATA SHEET)
Global on/off control	EN input	Run mode/sleep mode
Individual LED string on/off control	Not available	String enables register
Analog LED current adjustment	ILED input	Current setting register
PWM LED current adjustment	PWM input	PWM frequency and PWM duty ratio registers
Ambient light sensor (ALS) and/or auto-matic temperature LED current adjustment	IADJ input	
Fault monitoring	FLT input indicates open-string, shorted-string, and over-temperature faults	Status register identifies open/short circuit and over-temperature faults

# Atmel LED Driver-MSL 1060

6-string PWM LED Driver with Digitally Compensated, 1.1MHz, 48V Boost Regulator and  $\pm 1.5\%$  LED String Current Balance

## Packages and Connections

Atmel LED Driver-MSL1060 - 24 lead, 5mm x 5mm x 0.75mm TQFN package with 0.65mm lead pitch

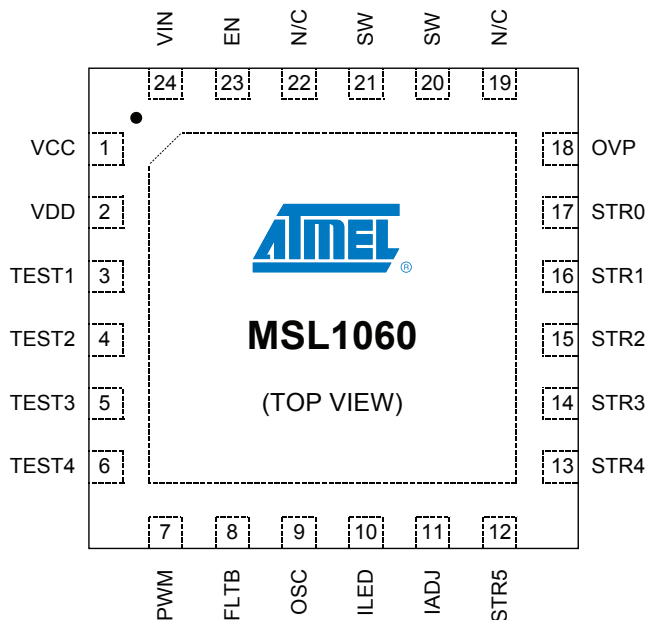
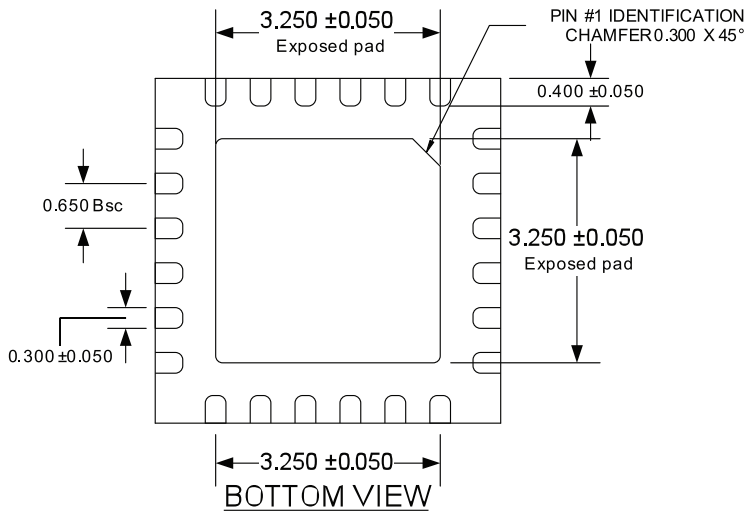
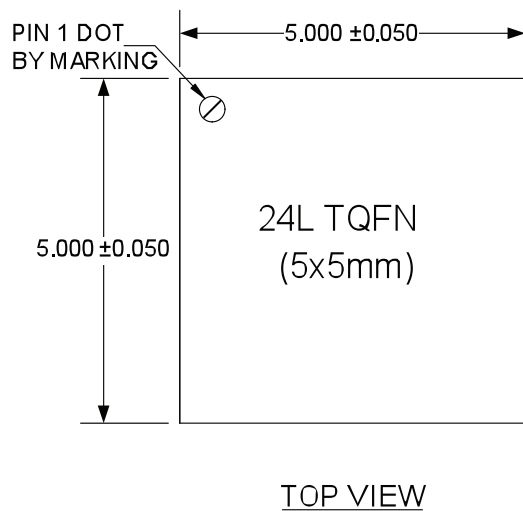

Figure 1. 24 – lead, 5mm x 5mm x 0.75mm TQFN (0.65mm lead pitch) with Exposed Pad



A	TQFN	
	MAX.	0.800
NOM.	0.750	
MIN.	0.700	

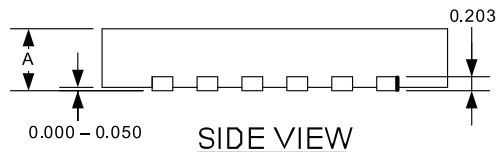

Figure 2. 24-lead TQFN Package Dimensions





## Connection Descriptions

**Table 3. Connection Assignments**

NAME	MSL1060	DESCRIPTION
VCC	1	<b>6V internal linear regulator output</b> VCC powers the internal power FET switch driver. Bypass VCC to GND either with a 10 $\mu$ F or greater ceramic capacitor. If the voltage at VIN is less than 6.5V, connect VCC directly to VIN to bypass the internal linear regulator, and power the driver directly from VIN
VDD	2	<b>2.85V internal linear regulator output</b> VDD powers internal logic Bypass VDD to GND with at least a 4.7 $\mu$ F ceramic capacitor
TEST1	3	Factory test connection. <b>Leave unconnected</b>
TEST2	4	Factory test connection. <b>Connect to GND</b>
TEST3	5	Factory test connection. <b>Connect to GND</b>
TEST4	6	Factory test connection. <b>Connect to GND</b>
PWM	7	<b>PWM control input</b> Drive PWM with a PWM signal up to 40kHz to pulse-width-modulate the LED current
FLTB	8	<b>Fault indication output (active low)</b> FLTB sinks current to GND whenever the MSL1060 detects a fault Once a fault is detected, FLTB remains low until EN is toggled low/high, or input power is cycled off/on
OSC	9	<b>Oscillator control input</b> Connect a 115k $\Omega$ , 1% resistor from OSC to GND to set the internal oscillator frequency which sets the boost regulator switching frequency to 1.1MHz
ILED	10	<b>Maximum LED current control input</b> Connect a resistor from ILED to GND to set the full-scale LED string current For example, connect a 100k $\Omega$ resistor to GND to set a 20mA sink current through each LED string
IADJ	11	<b>Analog LED current dimming input</b> Apply a voltage in the range of 0V to 1.22V to adjust LED current from 0 to 100%. Use IADJ for ambient light sensing, temperature compensation, or other LED control functions Connect IADJ to VDD if unused
STR5	12	<b>LED String 5 current sink output</b> Connect the cathode of LED String 5 to STR5 Connect STR5 to GND if unused
STR4	13	<b>LED String 4 current sink output</b> Connect the cathode of LED String 4 to STR4 Connect STR4 to GND if unused
STR3	14	<b>LED String 3 current sink output</b> Connect the cathode of LED String 3 to STR3 Connect STR3 to GND if unused
STR2	15	<b>LED String 2 current sink output</b> Connect the cathode of LED String 2 to STR2 Connect STR2 to GND if unused
STR1	16	<b>LED String 1 current sink output</b> Connect the cathode of LED String 1 to STR1 Connect STR1 to GND if unused
STR0	17	<b>LED String 0 current sink output</b> Connect the cathode of LED String 0 to STR0 Connect STR0 to GND if unused



# Atmel LED Driver-MSL 1060

6-string PWM LED Driver with Digitally Compensated, 1.1MHz, 48V Boost Regulator and  $\pm 1.5\%$  LED String Current Balance

NAME	MSL1060	DESCRIPTION
OVP	18	<b>Overvoltage detection input</b> Connect to a resistive voltage divider from the boost output voltage to OVP to set the overvoltage protection set point. The OVP threshold is 1.28V
N/C	19	No internal connection. <b>Leave unconnected</b>
SW	20, 21	<b>Drain of the internal boost power MOSFET switch</b> Connect all SW leads together and to the boost regulator inductor and rectifier
N/C	22	No internal connection. <b>Leave unconnected</b>
EN	23	<b>Active high enable input</b> Drive EN high to turn on the MSL1060, and drive it low to turn it off For automatic startup, connect EN to VIN through a 100k $\Omega$ resistor
VIN	24	<b>Supply voltage input</b> Connect the input supply voltage to VIN VIN powers the internal LDO regulator that powers VCC. Bypass VIN to GND with a 1 $\mu$ F or greater ceramic capacitor
GND	Exposed pad	<b>Ground</b>

## Absolute Maximum Ratings

### Voltage (With Respect to GND Exposed Pad on Package Underside)

VIN	-0.3V to +40V
VCC, EN	-0.3V to +8V
VDD, OVP, IADJ, FLTB, ILED, OSC, PWM	-0.3V to +3.6V
SW	-0.3V to +50V
STR0, STR1, STR2, STR3, STR4, STR5	-0.3V to +45V

### Current (Into Lead)

SW	$\pm 3$ A
STR0, STR1, STR2, STR3, STR4, STR5	$\pm 35$ mA
All other leads	$\pm 20$ mA

### Continuous Power Dissipation at 70°C

24-lead TQFN (see Note 2, Note 3)	2286mW
-----------------------------------	--------

**Ambient Operating Temperature Range  $T_A = T_{MIN}$  to  $T_{MAX}$**  ..... -40°C to +85°C

**Junction Temperature** ..... +125°C

**Storage Temperature Range** ..... -65°C to +125°C

**Lead Soldering Temperature, 10s** ..... +300°C



## Electrical Characteristics

(Circuit of Figure 16,  $V_{VIN} = 12V$ ,  $T_A = -40^{\circ}C$  to  $+85^{\circ}C$ , unless otherwise noted. Typical values are at  $T_A = +25^{\circ}C$ ) (Note 1)

PARAMETER	CONDITIONS AND NOTES	MIN	TYP	MAX	UNIT
<b>DC ELECTRICAL CHARACTERISTICS</b>					
VIN operating supply voltage	$V_{VIN} = V_{VCC}$	4.75		6.5	V
	VCC unconnected	6.5		36	V
VIN quiescent supply current	$V_{EN} = 3V, V_{PWM} = 0V$	$V_{VIN} = 12V$	4	14	mA
		$V_{VIN} = 6V, V_{VCC} = 6V$	4	14	mA
VIN shutdown supply current	$V_{EN} = V_{PWM} = 0V$	1	4	10	$\mu A$
VCC output voltage		5.6	6	6.3	V
VCC line regulation	$6.5V < V_{VIN} < 36V$	1	2	5	mV
VCC dropout voltage	$V_{VIN} = 6V, I_{VCC} = 5mA, V_{PWM} = 0V$	100	300	550	mV
VCC short-circuit current	$V_{VCC} = 0V$	30	80	150	mA
VCC UVLO threshold	$V_{VCC}$ rising, hysteresis = 150mV	4.1	4.3	4.5	V
VDD output voltage	$I_{VDD} = 1mA$	2.7	2.9	3.1	V
VDD short-circuit current	$V_{VDD} = 0V$	10	35	60	mA
VDD UVLO threshold	$V_{VDD}$ rising, hysteresis = 80mV	2.4	2.5	2.6	V
Thermal shutdown threshold (rising)			135		$^{\circ}C$
Thermal shutdown hysteresis			10		$^{\circ}C$

PARAMETER	CONDITIONS AND NOTES	MIN	TYP	MAX	UNIT
<b>DC ELECTRICAL CHARACTERISTICS - LED CURRENT CONTROL STR0 TO STR5</b>					
ILED regulation voltage	$R5 = 100k\Omega$	1.195	1.22	1.245	V
STR0 to STR5 full scale sink current	$V_{STRn} = 1V, R5 = 100k\Omega, V_{IADJ} = V_{PWM} = 3V$	19.7	20	20.3	mA
STR0 to STR5 maximum sink current	$V_{STRn} = 1V, R5 = 60k\Omega, V_{IADJ} = V_{PWM} = 3V$ (Note 4)	30			mA
STR0 to STR5 current matching	$V_{STRn} = 1V, R5 = 100k\Omega, V_{PWM} = 3V$ (Note 5)			1.5	%
STR0 to STR5 leakage current	$V_{EN} = 0V, V_{STRn} = 40V$		0.1	1	$\mu A$
	$V_{EN} = 3V, V_{STRn} = 40V, V_{PWM} = 3V$		0.1	1	$\mu A$
STR0 to STR5 short circuit detection threshold		4	4.4	4.8	V
STR0 to STR5 open circuit detection threshold			0.1		V

# Atmel LED Driver-MSL 1060

6-string PWM LED Driver with Digitally Compensated, 1.1MHz, 48V Boost Regulator and  $\pm 1.5\%$  LED String Current Balance

PARAMETER	CONDITIONS AND NOTES	MIN	TYP	MAX	UNIT
<b>DC ELECTRICAL CHARACTERISTICS - LOGIC I/Os</b>					
EN logic high input voltage		2.3			V
EN logic low input voltage				0.8	V
EN logic input current	$V_{EN} = 3V$			20	$\mu A$
EN logic input series resistance	Between EN input and internal Zener clamp		10.5		k $\Omega$
EN logic input Zener clamp			5.8		V
PWM logic high input voltage		2			V
PWM logic low input voltage				0.9	V
FLTB output low voltage	Sinking 1mA		0.1	0.2	V
IADJ, FLTB, PWM leakage current				10	$\mu A$

PARAMETER	CONDITIONS AND NOTES	MIN	TYP	MAX	UNIT
<b>DC ELECTRICAL CHARACTERISTICS - BOOST REGULATOR</b>					
SW on resistance	$I_{SW} = 100mA$		0.4	0.6	$\Omega$
SW current limit			2		A
OSC regulation voltage	$R4 = 115k\Omega \pm 1\%$	1.195	1.22	1.245	V
STR0-STR5 boost regulation voltage	$R5 = 100k\Omega$ , PWM=100% (Note 6)		600		mV
OVP threshold	$V_{OVP}$ rising	1.25	1.28	1.31	V
OVP hysteresis			60		mV
OVP leakage current	$V_{OVP} = 3.6V$			1	$\mu A$

PARAMETER	CONDITIONS AND NOTES	MIN	TYP	MAX	UNIT
<b>AC ELECTRICAL CHARACTERISTICS</b>					
PWM input frequency		0		50	kHz
PWM input duty ratio		0		100	%
Boost regulator switching frequency	$R4 = 115k\Omega \pm 1\%$	0.99	1.1	1.21	MHz
Boost regulator maximum duty ratio	$R4 = 115k\Omega \pm 1\%$	89	92		%
Boost regulator startup time			100	120	ms

Note 1. All parameters are tested at  $T_A = 25^\circ C$ , unless otherwise noted. Specifications at temperature are guaranteed by design

Note 2. Subject to thermal dissipation characteristics of the device

Note 3. When mounted according to JEDEC JEP149 and JESD51-12 for a two-layer PCB,  $\theta_{JA} = 24.1^\circ C/W$  and  $\theta_{JC} = 2.7^\circ C/W$

Note 4. Guaranteed by design and characterization. Not production tested

Note 5. STR0 to STR5 current matching is the difference between any one string current and the average of all string currents divided by the average of all string currents

Note 6. The MSL1060 selects the active string (STR0 through STR5) with the lowest voltage to control the boost regulator voltage



## Typical Operating Characteristics

(Circuit of Figure 16, VIN=12V, 6 strings of 10 LEDs per string, T<sub>A</sub> = +25°C, unless otherwise noted)

**Figure 3. System Efficiency Vs LED Duty Ratio**

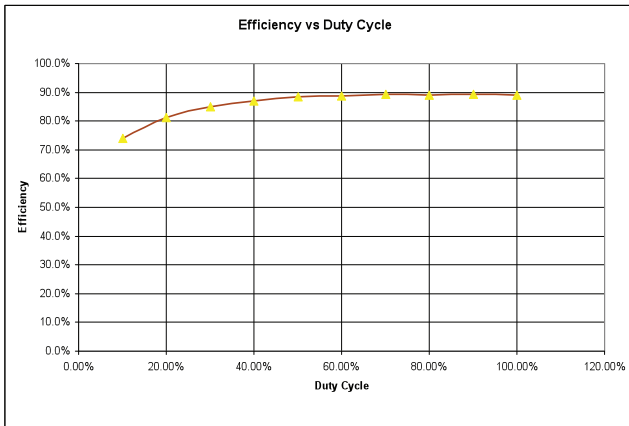

**Figure 6. Operating Current Vs VIN**

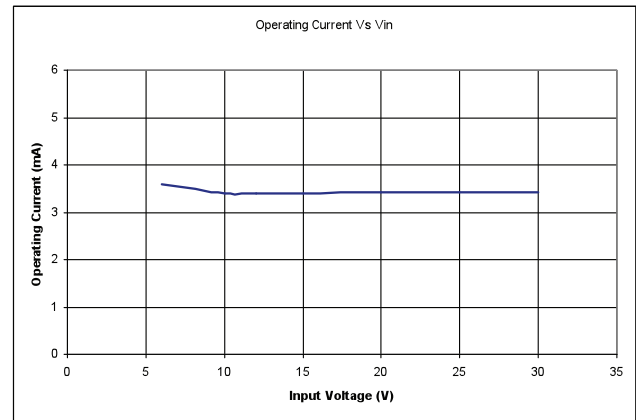

**Figure 4. LED Current Vs PWM Duty Ratio**

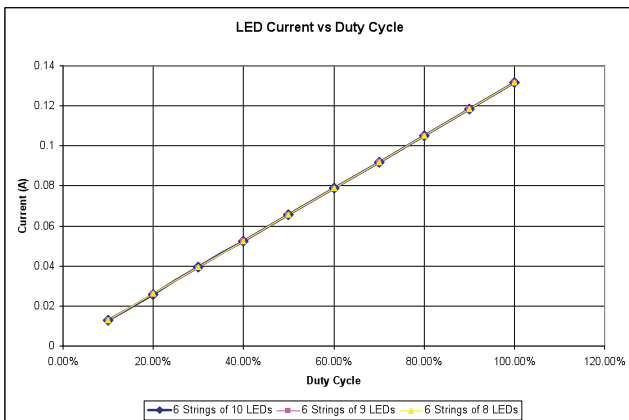

**Figure 7. VCC Load Regulation**

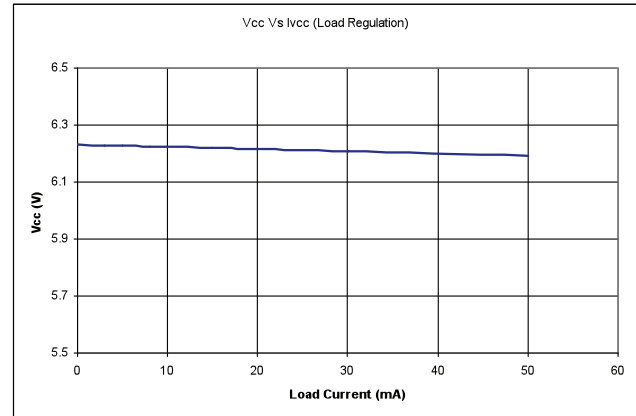

**Figure 5. Shutdown Current Vs VIN**

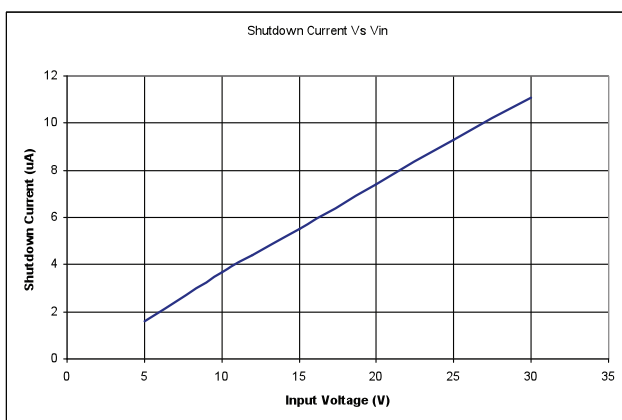

**Figure 8. VDD Load Regulation**

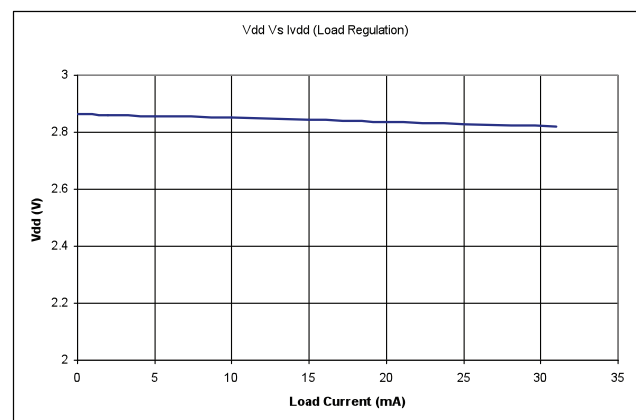

# Atmel LED Driver-MSL 1060

6-string PWM LED Driver with Digitally Compensated, 1.1MHz, 48V Boost Regulator and  $\pm 1.5\%$  LED String Current Balance

## Typical Operating Characteristics (continued)

Figure 9. IADJ Response

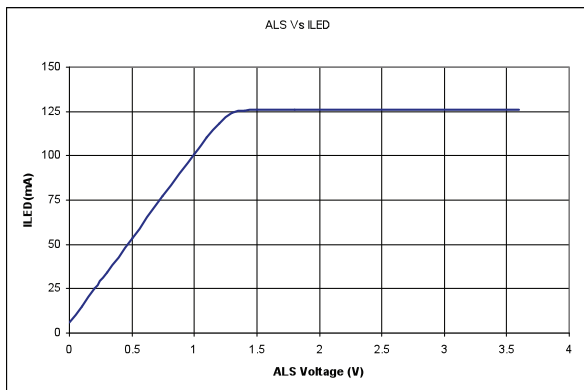

Figure 10. PWM Operation; Minimum D time

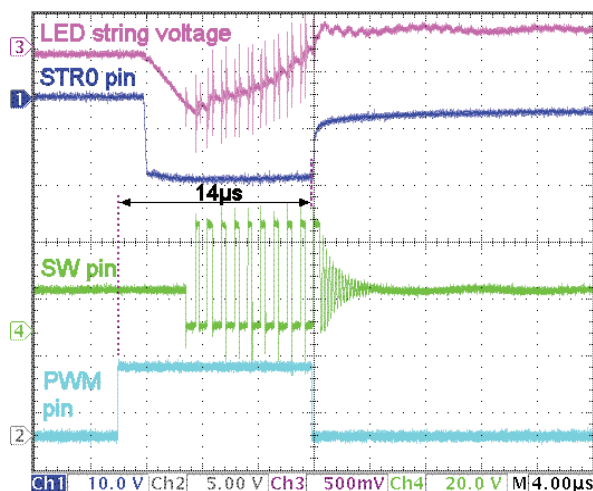

Figure 11. PWM Operation; Minimum Off Time

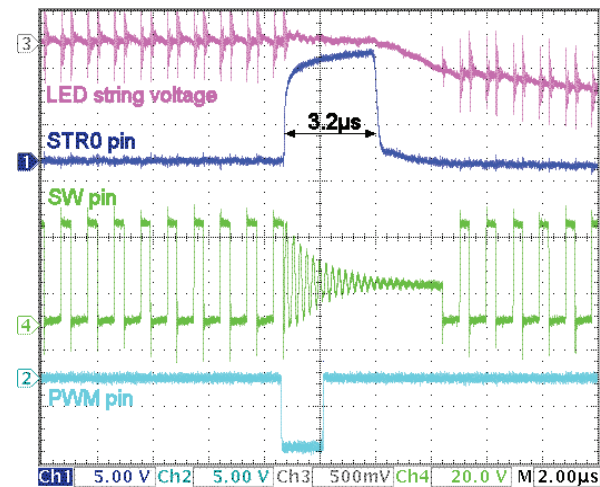

Figure 12. Open-circuit LED String Response

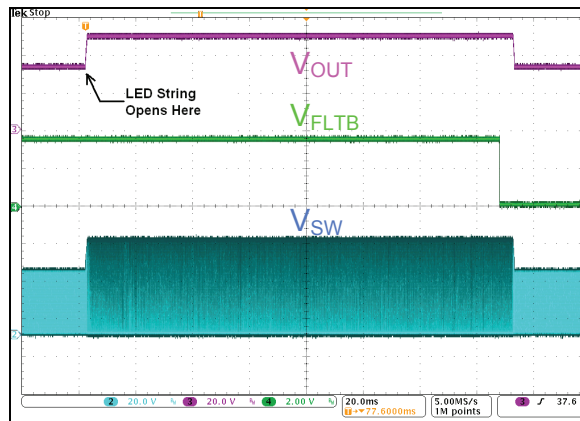

Figure 13. PWM Operation; F<sub>PWM</sub> = 200Hz, D = 10%

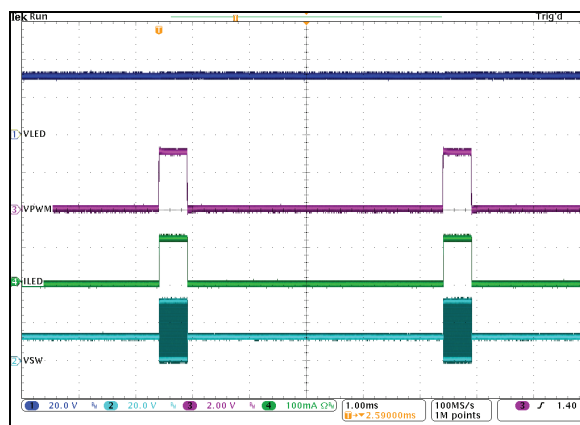
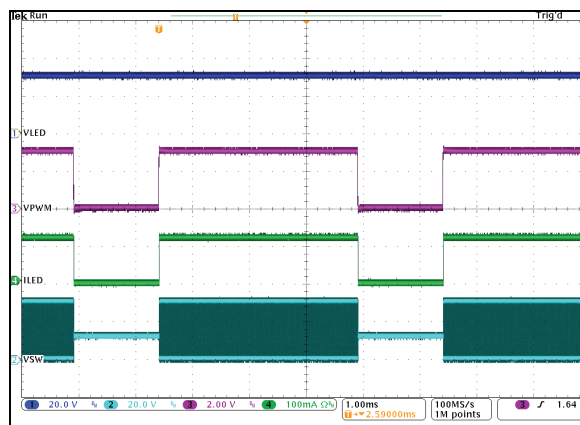

Figure 14. PWM Operation; F<sub>PWM</sub> = 200Hz, D = 70%



## Block Diagram

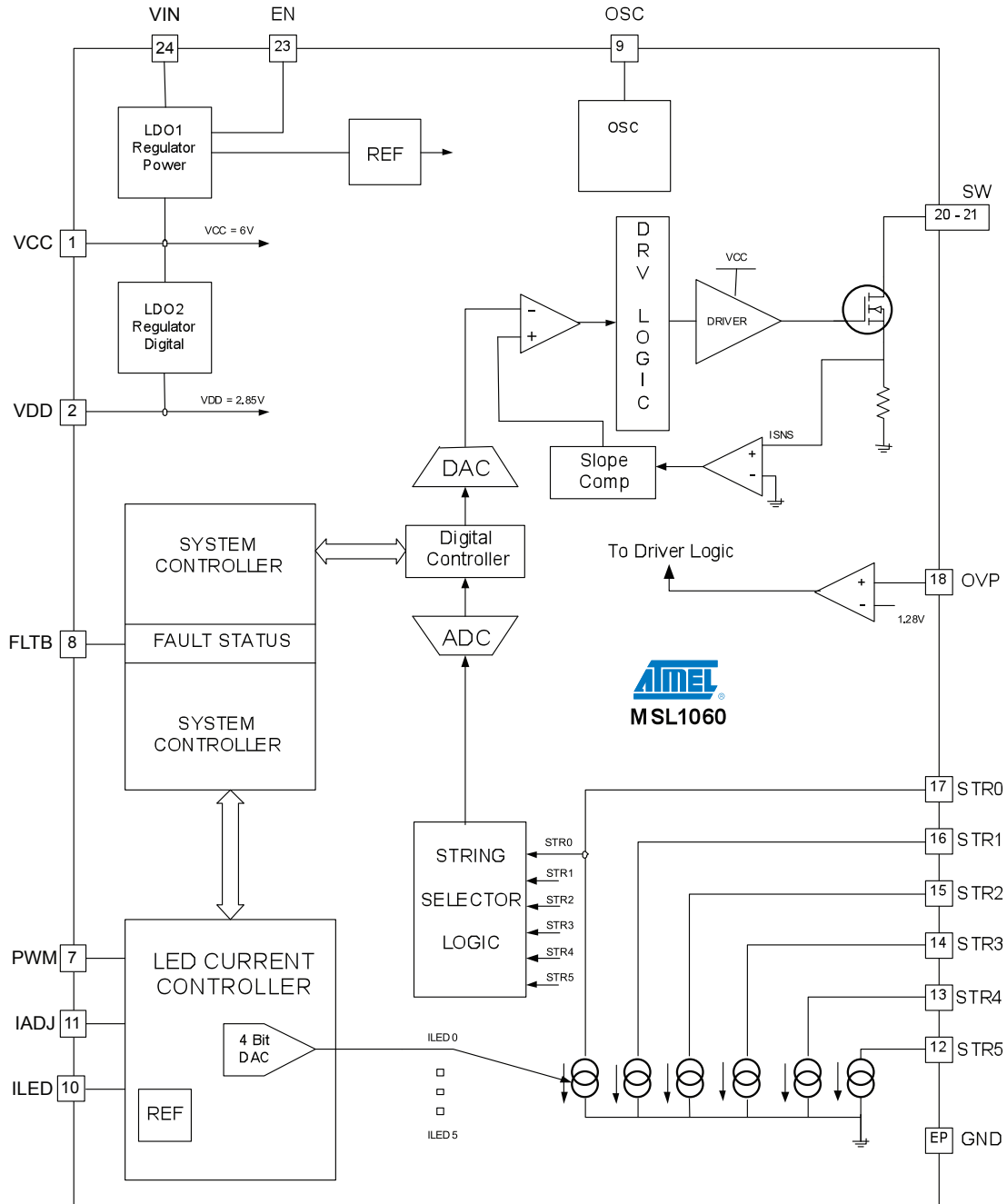

Figure 15. Atmel LED Driver-MSL1060 Block Diagram

# Atmel LED Driver-MSL 1060

6-string PWM LED Driver with Digitally Compensated, 1.1MHz, 48V Boost Regulator and  $\pm 1.5\%$  LED String Current Balance

## Typical Application Circuit

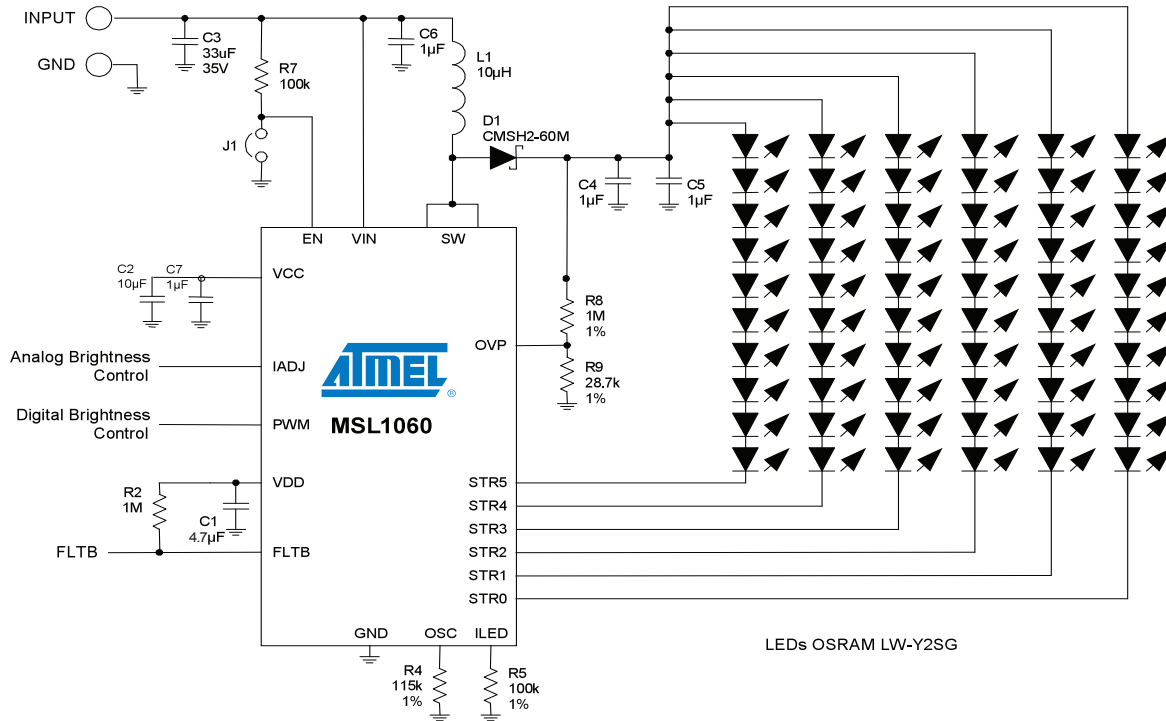

Figure 16. Backlight Example Driving 60 White LEDs

Table 4. Typ. Application Circuit Parameters

PARAMETER	VALUE
Minimum input voltage	4.75V
Maximum input voltage (set by minimum LEDs string voltage)	30V
Number of LEDs	60
Number of LED strings	6
Number of LED per string	10
LED forward current (set by R5)	20mA
White LED	Osram LW-Y3SG
Minimum LED forward voltage	2.9V
Typical LED forward voltage	3.3V
Maximum LED forward voltage	3.6V
Minimum LED string voltage	29V
Maximum LED string voltage	36V
Oscillator frequency (set by R4)	1.1MHz
Overshoot protection (OVP) trip point (set by R8 and R9)	45.9V

Table 5. Typ. Application Circuit Bill of Materials

COMPONENT	DESCRIPTION	VENDOR PART NUMBER
C4, C5, C6, C7*	1µF, 50V, X7R	
C2	10µF, 10V, X7R or tantalum (see note)	
C3	33µF, 35V, X7R	
C1	4.7µF, 6.3V, X7R	
R8	1MΩ, 1%	
R9	28.7kΩ, 1%	
R4	115kΩ, 1%	
R5	100kΩ, 1%	
R7	100kΩ, 5%	
R2	1MΩ, 5%	
L1	10µH, 1.7A	Sumida CDRH6D28-100
D1	60V, 2A Schottky	Central Semi CMSH2-60M
LEDs	60 x 30mA LED	Osram LW-Y2SG
LED driver	MSL1060	MSL1060

\* Note: C7 is only required if tantalum capacitor is used for C2





## Detailed Description

The MSL 1060 is an integrated boost regulator plus LED driver solution for driving an array of LEDs with up to 8W of power. The MSL 1060 is especially suited to drive up to 72 white LEDs for notebook computer backlighting. It is also suitable for industrial lighting and signage applications, and can for example drive a 6 string x 18 series LED array, totaling 108 red LEDs (2.5V LED forward voltage drop).

The MSL 1060 includes 6 current sinks (STR0 through STR5) that each control the LED current of series connected LEDs. A built-in step-up regulator supplies power to the LEDs. The MSL 1060 controls the output voltage of the boost regulator such that all LED strings have sufficient voltage to maintain regulated LED current. This control loop operates automatically without any user interaction.

### LED Current Sinks

The LEDs are connected in both series and parallel combinations. The MSL 1060 powers up to six parallel strings with each string having up to 12 series-connected white LEDs. The MSL 1060 internally controls the current of each string to ensure that all LEDs operate at the same current. The MSL 1060 measures the voltage at each of the current sink outputs, STR0 to STR5, and determines which has the lowest voltage. It uses this voltage to control the internal boost regulation voltage such that all current sink voltages have sufficient headroom to maintain high current accuracy and matching.

Use equal numbers of LEDs with the same part number in each LED string to maintain the same nominal voltage drop across each string. If the number or type of LEDs on each string does not match, the MSL 1060 adjusts the LED voltage so that the largest-forward-voltage string has enough voltage at its current sink for the necessary current accuracy and matching. If there's excessive variation between the voltages at the STR0 to STR5 current sinks, the MSL 1060 dissipates extra power, thereby reducing power efficiency.

By matching LED string voltages, the voltage drop across each string driver (the current sink outputs STR0 to STR5) is also matched. This allows the LED driver to adjust the boost regulator output voltage to minimize voltage headroom and thus power dissipation. Minimizing string driver dissipation optimizes efficiency.

Disable unused current sink outputs by connecting them to GND. At startup, the MSL 1060 checks each current sink output, STR0 to STR5, to determine if the respective LED string shorted to GND. If a current sink output is connected to GND, the MSL 1060 detects that as an unused string and disables it.

### PWM Brightness Control

The MSL 1060 uses an external PWM signal whose waveform (frequency and duty) directly controls the current sink outputs, STR0 to STR5. The MSL 1060 turns-on all active LED strings when the PWM input is high, and turns them off when it is low. Transition the external PWM signal between the 0.9V maximum logic low level and the 2.0V minimum logic high level as quickly as possible to allow the MSL 1060 to produce an accurate PWM dimming time without jitter. Also, the 14 $\mu$ s LED string output fall time and 3.2 $\mu$ s rise time limit the external PWM to 230Hz for 8-bit (256:1) brightness resolution at the lowest end of the PWM duty range.

# Atmel LED Driver-MSL 1060

## 6-string PWM LED Driver with Digitally Compensated, 1.1MHz, 48V Boost Regulator and $\pm 1.5\%$ LED String Current Balance

### Boost Regulator

The MSL 1060 includes a built-in boost regulator that supplies voltage to the LEDs. The boost output voltage ranges from the input voltage up to 48V. The boost regulator generates the voltage at the top (anode end) of each parallel LED string (Figure 15, Figure 16) anywhere between the boost input voltage and 48V. The voltage is automatically set by the MSL 1060 such that the LED string with the highest forward voltage remains above the minimum voltage required to ensure LED current accuracy and matching.

The boost regulator is compensated internally using digital control. This reduces the number of external components and allows the control system to save the operating point during the PWM off time, minimizing the required recovery at LED turn on. The current mode regulation system operates at a fixed 1.1MHz switching frequency for easy control of noise. The high switching frequency allows for a small external inductor and capacitors, reducing size and cost. The switch current is internally limited to 2A to prevent overstress in the event a boost regulator overload condition.

For maximum power efficiency, ensure that the minimum forward voltage of a series LED string is greater than the maximum input voltage to the boost regulator. The boost regulator by nature includes a DC path through the inductor and rectifier to the boost output voltage, and, therefore, the MSL 1060 cannot control the LED voltage lower than the input voltage. If the series LED string voltage is less than the input voltage, the boost regulator turns off and the voltage at the anode end of the string is approximately the input voltage, and so the current sink outputs STR0 to STR5 drop the difference between the string forward voltage and the input voltage. Any increase in voltage across current sink outputs STR0 to STR5 reduces power efficiency.

### Fault Management

The MSL 1060 includes comprehensive fault detection circuitry. The MSL 1060 automatically detects and corrects for open circuit LED strings, short circuit LEDs, boost regulator overload, and die over-temperature faults. The open-drain FLTB output indicates faults by sinking current to GND. Reset faults by cycling the EN input low and then high.

### LED String Faults

If an open or short circuit LED string fault occurs, the MSL 1060 automatically disables the faulty LED string, and asserts the active-low, open-drain FLTB output to alert the system of the fault.

### Die Over-temperature Fault

If the MSL 1060 detects die over-temperature ( $135^{\circ}\text{C}$ ), it turns-off until the die cools. The MSL 1060 restarts automatically when the die is cooled by  $15^{\circ}\text{C}$ , allowing control by the EN and PWM inputs.



## Application Information

### VCC and VDD Regulators

The MSL 1060 includes two linear voltage regulators to generate the internal voltage rails, VDD and VCC. The regulators allow the same higher voltage supply, VIN, which supplies the LED boost regulator to power the MSL 1060 internal circuitry. Only use the VDD and VCC regulators to power the MSL 1060's internal circuitry; do not draw any external current from the regulators.

The VCC regulator generates a 6V rail from VIN. VCC powers the boost regulator's power switch and the VDD regulator. Bypass VCC to GND either with a 10µF or greater ceramic capacitor or with a 10µF or greater tantalum capacitor in parallel with a 1µF ceramic capacitor.

In applications where there is a local 4.75V to 6.5V supply available, power VCC powered directly from this supply by connecting VCC and VIN together to this 4.75V to 6.5V supply. A higher voltage supply can still be used to power the LED boost regulator by applying the voltage to the inductor, L1 (Figure 16), and not the MSL1060.

The VDD regulator generates a 2.85V rail from VCC. VDD operates the internal low-voltage circuits. Bypass VDD to GND with a 1µF or greater capacitor.

### Internal Oscillator - R4

Set the MSL 1060 internal oscillator frequency with resistor R4 from OSC to GND (Figure 16). Use a 115kΩ ±1% resistor for R4, which also sets the boost regulator PWM frequency to 1.1MHz. Changing the internal oscillator frequency alters the boost regulator internal frequency compensation degrading performance. Do not use a different value for R4, or else the MSL 1060 performance is not guaranteed.

### Setting the Full-scale LED String Current - R5

Set the full-scale static LED current for all enabled strings with the resistor, R5 (Figure 16), from ILED to GND. The maximum full-scale LED current is 30mA. Calculate the resistor R5 value to set the full-scale LED string current  $I_{ILED}$  by the equation:

$$I_{ILED} = \frac{2000}{R5}$$

where R5 is in kilohms and ILED is in milliamperes.

Resistor R5 value of 100kΩ sets the full-scale LED current to 20mA. Use R5 value not less than 66.7kΩ, which sets the full-scale LED current to 30mA.

### Enable Input - R7

The EN input turns on/off the MSL 1060. Drive EN high (or connect to VIN through resistor R7) to turn on the MSL 1060, and drive EN low to turn it off. The EN input is internally over-voltage protected (Figure 17) to allow connection to a higher voltage than the 8V maximum input voltage rating by use of an ESD clamp at the input, which sinks current if the input exceeds typically 12V. An internal 10.5kΩ series resistor followed by a 5.8V Zener diode further limits the voltage to the internal logic buffer. Use an external series resistor, R7 to limit the ESD clamp current to no more than 20mA if EN is driven to a voltage higher than 8V. Use R7 value of 100kΩ when driving EN high to voltages above 8V, and omit R7 (directly drive EN) for voltages below 8V.

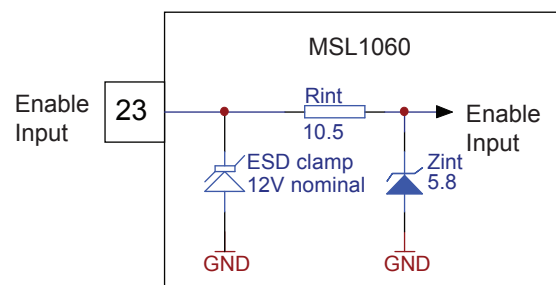

**Figure 17. Atmel LED Driver-MSL 1060 Enable Input Internal Protection Circuit**

# Atmel LED Driver-MSL 1060

## 6-string PWM LED Driver with Digitally Compensated, 1.1MHz, 48V Boost Regulator and $\pm 1.5\%$ LED String Current Balance

### IADJ Input - LED Temperature Compensation and/or Ambient Light Sensing

The MSL 1060 analog control input, IADJ, allows reduction of the full-scale static LED current from the current set by resistor R5. IADJ controls the LED current proportionally to the voltage on IADJ, between 0V and 1.22V. For example, setting IADJ to 0V reduces the full-scale static LED current to zero. Setting IADJ to 0.61 V reduces the full-scale static LED current to half. IADJ voltage greater than 1.22V retains full-scale static LED current. If analog control is not used, connect IADJ to VDD.

For automatic temperature compensation, connect a negative-temperature-co-efficient (NTC) thermistor from VDD to IADJ and a resistor from IADJ to GND. As temperature rises, the voltage at IADJ also increases, effectively increasing the LED current.

For automatic ambient light compensation, connect a photodiode or integrated ambient light sensor (ALS) to the IADJ input. As ambient light intensifies, the voltage at IADJ also increases, effectively increasing the LED current.

### Boost Regulator Components

The internally compensated boost regulator, includes an internal, high-voltage FET power switch, and requires only an inductor, rectifier, and bypass capacitors to operate. The current mode boost regulator operates in continuous conduction mode (CCM) or discontinuous conduction mode (DCM). In CCM, the inductor current does not fall to zero when operating at full power, which reduces inductor ripple current and switching noise. The boost regulator and internal compensation switches at 1.1MHz. Use 115k $\Omega$  for resistor R4 from OSC to GND (Figure 16) to set the oscillator frequency. Select the inductor, rectifier diode, and output capacitors according to the following guidelines.

To select inductor use the following equations

$$L = \frac{(V_{in}) * \left(1 - \frac{V_{in}}{V_{out}}\right)}{(0.3) * (I_{in}) * (f_{sw})}$$

Where

$V_{out}$  = Forward voltage of LED string + 0.6V

$V_{in}$  = Input voltage

$f_{sw}$  = Switching frequency of boost controller, this is 1.1MHz for MSL 1060

and

$$I_{in} = \frac{I_{LED(total)} * V_{out}}{0.9 * V_{in}}$$

Choose an inductor with a peak current rating > 2A. Common inductor values can range from 4.7 $\mu$ H to 22 $\mu$ H.

To minimize losses in the rectifier, choose a fast-switching diode with low forward drop. Ensure that the rectifier can withstand a reverse voltage equal to the regulator output voltage. The average forward current is equal to the total LED string current (for example 6 strings x 30mA = 180mA), while the peak current is equal to the inductor peak current (2A).

The boost output capacitor holds the voltage at the output of the boost regulator while the internal power switch is on. Use ceramic boost output capacitors because of their small size and high ripple current capacity. Derate ceramic capacitors for operating voltage because the voltage coefficient decreases the effective capacitance with increased operating voltage. Use two parallel-connected 1 $\mu$ F 100V X7R ceramic capacitors and a 10 $\mu$ H inductor with a 1.7A peak current rating.

### Over-voltage Protection (OVP) - R8 and R9

The OVP input sets the boost regulator's output voltage upper limit, and protects the boost regulator from common faults such as open circuit LEDs. Resistors R8 and R9 (Figure 16) set the OVP voltage  $V_{TRIP}$  is set by:

$$V_{TRIP} = V_{OVP} \frac{(R8 + R9)}{R9}$$

where  $V_{OVP}$  = 1.28V, nominal.



**Atmel Corporation**

2325 Orchard Parkway  
San Jose, CA 95131  
USA

**Tel:** (+1)(408) 441-0311

**Fax:** (+1)(408) 487-2600

[www.atmel.com](http://www.atmel.com)

**Atmel Asia Limited**

Unit 01-5 & 16, 19F  
BEA Tower, Millennium City 5  
418 Kwun Tong Road  
Kwun Tong, Kowloon  
HONG KONG

**Tel:** (+852) 2245-6100

**Fax:** (+852) 2722-1369

**Atmel Munich GmbH**

Business Campus  
Parking 4  
D-85748 Garching b. Munich  
GERMANY

**Tel:** (+49) 89-31970-0

**Fax:** (+49) 89-3194621

**Atmel Japan**

9F, Tonetsu Shinkawa Bldg.  
1-24-8 Shinkawa  
Chuo-ku, Tokyo 104-0033  
JAPAN

**Tel:** (+81)(3) 3523-3551

**Fax:** (+81)(3) 3523-7581

© 2011 Atmel Corporation. All rights reserved. / Rev.: MEM-MSL1060DS1-E-US\_06-11

Atmel®, logo and combinations thereof, and others are registered trademarks or trademarks of Atmel Corporation or its subsidiaries. Other terms and product names may be trademarks of others.

Disclaimer: The information in this document is provided in connection with Atmel products. No license, express or implied, by estoppel or otherwise, to any intellectual property right is granted by this document or in connection with the sale of Atmel products. EXCEPT AS SET FORTH IN THE ATMEL TERMS AND CONDITIONS OF SALES LOCATED ON THE ATMEL WEBSITE, ATMEL ASSUMES NO LIABILITY WHATSOEVER AND DISCLAIMS ANY EXPRESS, IMPLIED OR STATUTORY WARRANTY RELATING TO ITS PRODUCTS INCLUDING, BUT NOT LIMITED TO, THE IMPLIED WARRANTY OF MERCHANTABILITY, FITNESS FOR A PARTICULAR PURPOSE, OR NON-INFRINGEMENT. IN NO EVENT SHALL ATMEL BE LIABLE FOR ANY DIRECT, INDIRECT, CONSEQUENTIAL, PUNITIVE, SPECIAL OR INCIDENTAL DAMAGES (INCLUDING, WITHOUT LIMITATION, DAMAGES FOR LOSS AND PROFITS, BUSINESS INTERRUPTION, OR LOSS OF INFORMATION) ARISING OUT OF THE USE OR INABILITY TO USE THIS DOCUMENT, EVEN IF ATMEL HAS BEEN ADVISED OF THE POSSIBILITY OF SUCH DAMAGES. Atmel makes no representations or warranties with respect to the accuracy or completeness of the contents of this document and reserves the right to make changes to specifications and products descriptions at any time without notice. Atmel does not make any commitment to update the information contained herein. Unless specifically provided otherwise, Atmel products are not suitable for, and shall not be used in, automotive applications. Atmel products are not intended, authorized, or warranted for use as components in applications intended to support or sustain life.

## X-ON Electronics

Largest Supplier of Electrical and Electronic Components

*Click to view similar products for [LED Lighting Drivers](#) category:*

*Click to view products by [Microchip](#) manufacturer:*

Other Similar products are found below :

[LV5235V-MPB-H](#) [MB39C602PNF-G-JNEFE1](#) [MIC2871YMK-T5](#) [AL1676-10BS7-13](#) [AL1676-20AS7-13](#) [AP5726WUG-7](#) [MX877RTR](#)  
[ICL8201](#) [IS31BL3228B-UTLS2-TR](#) [IS31BL3506B-TTLS2-TR](#) [AL3157F-7](#) [AP5725FDCG-7](#) [AP5726FDCG-7](#) [LV52204MTTBG](#)  
[AP5725WUG-7](#) [STP4CMPQTR](#) [NCL30086BDR2G](#) [CAT4004BHU2-GT3](#) [LV52207AXA-VH](#) [AP1694AS-13](#) [TLE4242EJ](#) [AS3688](#)  
[IS31LT3172-GRLS4-TR](#) [TLD2311EL](#) [KTD2694EDQ-TR](#) [KTZ8864EJAA-TR](#) [IS32LT3174-GRLA3-TR](#) [ZXLD1374QESTTC](#) [MP2488DN-](#)  
[LF-Z](#) [NLM0010XTSA1](#) [AL1676-20BS7-13](#) [MPQ7220GF-AEC1-P](#) [MPQ4425BGJ-AEC1-P](#) [MPQ7220GF-AEC1-Z](#) [MPQ4425BGJ-AEC1-Z](#)  
[IS31FL3737B-QFLS4-TR](#) [IS31FL3239-QFLS4-TR](#) [KTD2058EUAC-TR](#) [KTD2037EWE-TR](#) [DIO5662ST6](#) [IS31BL3508A-TTLS2-TR](#)  
[MAX20052CATC/V+](#) [MAX25606AUP/V+](#) [BD6586MUV-E2](#) [BD9206EFV-E2](#) [BD9416FS-E2](#) [LYT4227E](#) [LYT6079C-TL](#) [MP3394SGF-P](#)  
[MP4689AGN-P](#)