

PD70211EVB50FW-5

5V/50W Isolated Active Clamp Forward Converter PD

Evaluation Board User Guide

Revision 2.0



PRODUCTION DATA – Information contained in this document is proprietary to Microsemi and is current as of publication date. This document may not be modified in any way without the express written consent of Microsemi. Product processing does not necessarily include testing of all parameters. Microsemi reserves the right to change the configuration and performance of the product and to discontinue product at any time.

1 About this Guide

This user guide provides both description and operation procedures for Microsemi's PD70211EVB50FW evaluating board. This board is used for evaluating the performance of PD70211A PD controller with integrated switching regulator, and PD70224 Dual MOSFET – Based Bridge Rectifier.

PD70211ILQ device supports both the standard IEEE802.3at PD application interface, and a PWM controller that is used to provide the PD operational voltage.

The evaluation board supports a 50 Watt, 5V output in its existing configuration, with no heat sink, at room temperature.

1.1 Audience

This user guide is intended for qualified personnel, meaning operators and technicians who have a background in basic concepts of electronics.

1.2 Organization

This guide is divided into several sections as follows:

• Chapter 1	About this Guide: Describes the objectives, audience, and organization.
• Chapter 2	Introduction: Provides an overview about evaluation board's main functions, features, physical characteristics and ordering information.
• Chapter 3	Physical Description: Provides explanation related to the physical description (switches, jumpers, connectors).
• Chapter 4	Electrical Characteristics: Provides electrical characteristics of the evaluation board.
• Chapter 5	Installation: Provides description of the installation process.
• Chapter 6	Test Data: Provides board test data information
• Chapter 7	Schematic: Provides board schematic diagram
• Chapter 8	List of Material: Provides board's list of materials.
• Chapter 9	Board Layout: Provides board Gerber files description for all layers..

1.3 Reference Documents

PD70211 datasheet, catalogue number DS_PD70211

PD70224 datasheet, catalogue number DS_PD70224

2 Introduction

Microsemi's PD70211ILQ device is part of a family of devices which are targeted for realizing the 802.3at standard PD interface.

The PD interface family of devices includes the following:

Device type	Power capability	Integrates PWM controller
PD70100	IEEE802.3at Type 1 (IEEE802.3 af level)	No
PD70101	IEEE802.3at Type 1 (IEEE802.3 af level)	Yes
PD70200	IEEE802.3at Type 2	No
PD70201	IEEE802.3at Type 2	Yes
PD70210(A)	2 x IEEE802.3at Type 2 (4 pair) HDBaseT (95W)	No
PD70211	2 x IEEE802.3at Type 2 (4 pair) HDBaseT (95W)	Yes

Microsemi's PD70211EVB50FW Evaluation Board (see

Figure 2) provides designers with an environment needed for evaluating the performance and implementation of PD applications based on PD70211 controller.

The board is using a single PD controller, PD70211ILQ, to support the Detection, Class, and Power Supplying phases on the 4 Pairs of the Cat5 cable. The board supports sync detection of the 4 pairs. PD70211ILQ supports the current of the HDBaseT over 4 Pairs, which is more than twice the power of a standard IEEE802.3AT Type 2 interface.

All necessary steps and connection instructions required to install and operate this board are provided within this document.

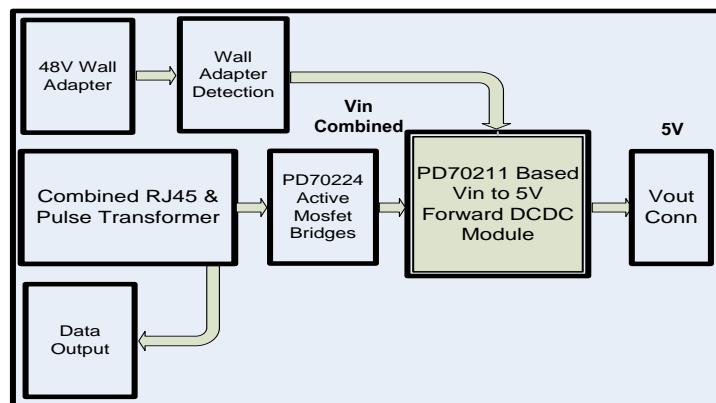

Figure 1: PD70211EVB50FW-5 Block Diagram



Figure 2: PD70211EVB50FW Evaluation Board – General View

Evaluation Boards Ordering Information

Microsemi supplies the following Evaluation Board as shown below:

Ordering Number	Description
PD70211EVB50FW-5	2 x IEEE802.3at Type 2 (4 pair) PD based on PD70211 device having 4 pair supply, controlling an isolated Forward converter , having a 5V 10 Amp output.

2.1 Evaluation Board Features

- Designed to support Data and Spare current by a single PD70211A device
- Power is supplied through the 4-pairs of the Cat5 cable
- Wall Adapter input – Standard Barrel Jack available for connecting to an external 48V Wall Adapter.
- Data pass-through connector
- On board PSE class type LED indicators
- On board AT detected LED indicator
- On board 4P_AT detected LED indicator
- On board HD detected LED indicator
- On board 4P_HD detected LED indicator
- On board Power Good LED indicator which may be configured to monitor PD Front End or VPP UVLO.
- Ta: 0° to +70°C (with derating curve)
- RoHS compliant

2.2 Physical Characteristics

Table 1 lists evaluation board's physical characteristics.

Table 1: Physical Characteristics

Parameter	Value
Mechanical dimensions in mm	165 x 57 x 16 mm (L x W x H)

3 Physical Description

3.1 Package Contents

Upon opening the Evaluation Board package, verify the following part is included.

If it seems damaged, contact local representative or Microsemi's headquarters.

Package content for standard shipments is:

- PD70211EVB50FW Evaluation Board.
- Wall Adapter Input Cable

3.2 Connectors

The following sections provide both general and detailed information regarding unit's connectors.

3.2.1 Connectors Table

Table 2 lists the Evaluation Board's connectors.

Table 2: Connectors List

#	Connector	Name	Description
1	J1	RJ45 Connector	RJ45 port for Data + Power In for PSE connection
2	J2	Wall Adapter Input	Standard Barrel Jack used for 48V Wall Adapter. Wall adapter connection will be automatically sensed and will override the PSE power connected to J1.
3	J3, TP6 (-) and TP5 (+)	Converter Output	Terminal pins for connecting a load to 5V output. J3 provides screw terminals for easy connection; TP5 and TP6 provide solder pads for soldered connection.
4	J4	RJ45 Connector	RJ45 port for Data pass – through output
5	VIN+, VINRTN	Converter Input Monitor	Converter Input Rail Monitor – Used as a monitor for DC-DC primary rail voltage.
6	TP1 and TP2	Frequency Analyzer Connection	Used to connect to an external frequency response analyzer for measuring loop stability.

3.2.2 Connectors Detailed Explanation

(The numbering is in reference to the numbers listed in Table 2.)

1. RJ45 Connectors.

See Figure 3.

Table 3: RJ45 Connectors

J1 & J4 Pin No	Signal Name	Description
J1 - 1, 2	Data and Power In	Data and power input to powered device (PoE Master Negative data port)
J1 - 3, 6	Data and Power In	Data and power input to powered device (PoE Master Positive data port)
J1 - 4, 5	Data and Power In	Data and power input to powered device (PoE Master Positive data port)

J1 & J4 Pin No	Signal Name	Description
J1 - 7, 8	Data and Power In	Data and power input to powered device (PoE Master Negative data port)
J4 - 1, 2	Data Output	Isolated data pass-through to external monitoring device.
J4 - 3, 6	Data Output	Isolated data pass-through to external monitoring device.
J4 - 4, 5	Data Output	Isolated data pass-through to external monitoring device.
J4 - 7, 8	Data Output	Isolated data pass-through to external monitoring device.

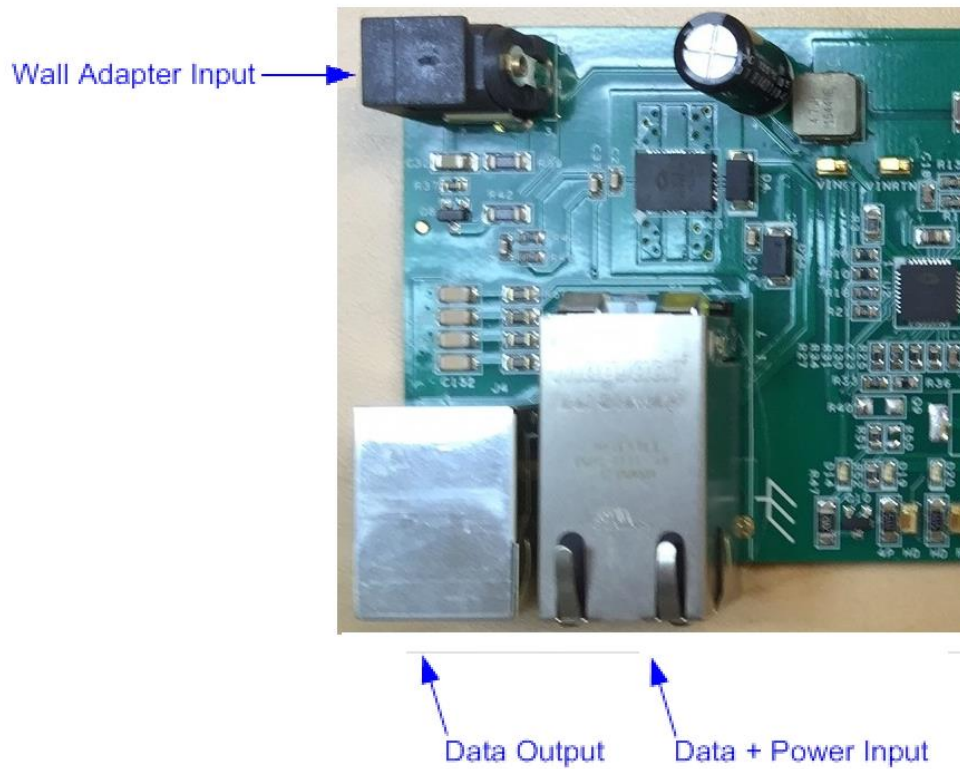

Figure 3: Front RJ45 and Auxiliary 48V Wall Adapter Connectors

2. Wall Adapter Connections

See Figure 3.

J2 Pin No	Signal Name	Description
Center Pin	VIN (+)	42V to 57V input from wall adapter.
Outer Barrel	VIN (-)	Wall Adapter Return

3. V_{out} Connections
 See Figure 4.

Table 4: Output Load Connections

Pin No.	Signal Name	Description
J3 - 2	Vout (-)	Return of DCDC output voltage
J3 - 1	Vout (+)	Positive DCDC output voltage
TP6	Vout (-)	Return of DCDC output voltage
TP5	Vout (+)	Positive DCDC output voltage

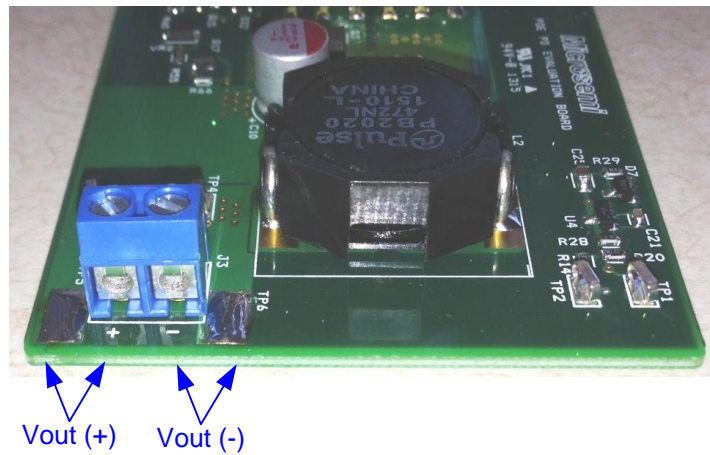

Figure 4: V_{out} Connections



3.3 Indications

The following sections provide general information regarding unit's indications.

1. LED Indication

See Figure 5.

3.3.1.1 LED Indication

See Figure 5.

D16 is the AT_FLAG indication LED, a PD70211 device output signal indicating the device has detected a 2 finger class event from the PSE side in the class stage. The flag will be operative at 3, 4, and 6 fingers detection as well.

D15 is the 4P_AT indication LED, a PD70211 device output signal indicating the device has detected a 4 finger class event from the PSE side in the class stage, or a 2 finger class event from the PSE side in the class stage, and SUPP_Sa and SUPP_Sb are both High.

The flag will be operative at 6 fingers detection as well.

D20 is the HD_FLAG indication LED, a PD70211 device output signal indicating the device has detected a 3 finger class event from the PSE side in the class stage.

The flag will be operative at 6 fingers detection as well.

D19 is the 4P_HD indication LED, a PD70211 device output signal indicating the device has detected a 6 finger class event from the PSE side in the class stage.

D14 is the Power Good indication. This LED indicates the presence of power. This indicator may be configured to monitor PD Front End VAUX (Asserts when VPP = 36V min.; de-asserts when VPP = 31V min.), or it may be configured to monitor the VPP UVLO, which is user selectable by the resistor values at VINS and HYST pins (R13, R19, and R25). See the PD70211 datasheet for further details regarding setting VPP UVLO limits. EVB default for Power Good EVB is monitoring VPP UVLO, and will track the operation of the DC-DC converter. To change Power Good to monitor PD Front End VAUX:

- 1) Remove R51, 100 Ohm Resistor (located on PCB bottom under D10).
- 2) Add R50 Zero Ohm Jumper (Also located on PCB bottom under D10).
- 3) Insure that only R51 or R50 are installed; do not operate with both resistors installed.

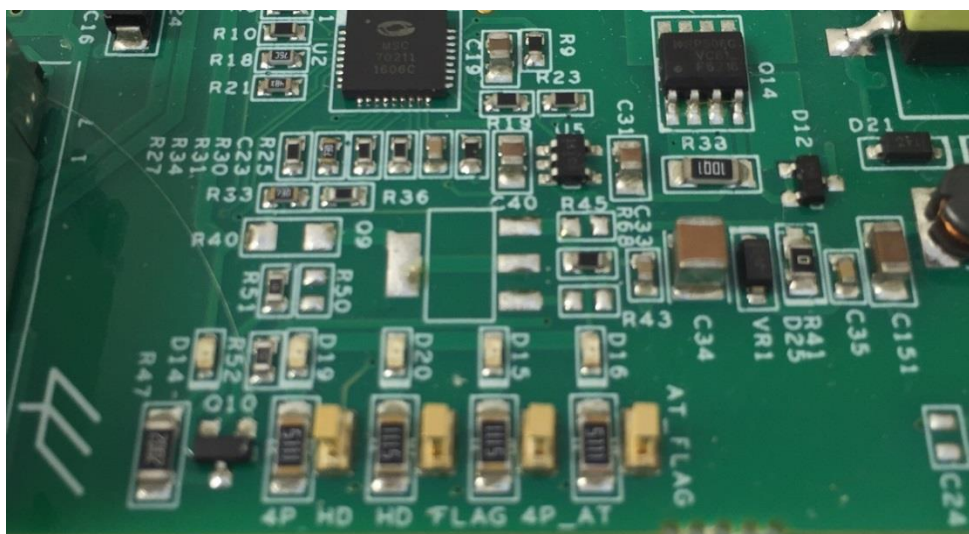

Figure 5: LED Indications

4 Electrical Characteristics

Evaluation board's electrical characteristics are described below:

Table 5: Electrical Characteristics

Parameter		Min	Max	
Main DC Supply – J1, VIN+, VINRTN		42*	57	V
Wall Adapter Supply – J2, VIN+, VINRTN		42	57	V
Maximum Available Current			10	A
Port Isolation to Chassis		-	1.5	kVrms

*After start-up, the minimum voltage is 37V with load \leq 13W per IEEE specification.

5 Installation

5.1 Preliminary Considerations and Safety Precautions

- If using an external supply in place of a PSE, verify the external power supply is turned “off” before all peripheral devices are connected. Insure the external supply is connected to the RJ45 input (J1) per Table 3.

5.2 Initial Configuration

Note: It is important to verify evaluation board is setup as shown in Figure 6 prior to starting any operation.

1. Connect load to evaluation board (J3 -1 (+) & J3 - 2 (-), or TP17 (+) & TP16 (-)).
 2. Connect a Cat5 cable from PSE to Evaluation Board (J1), or a 48V Wall Adapter to Evaluation Board (J2).
- Note: Wall Adapter will override power from PSE.

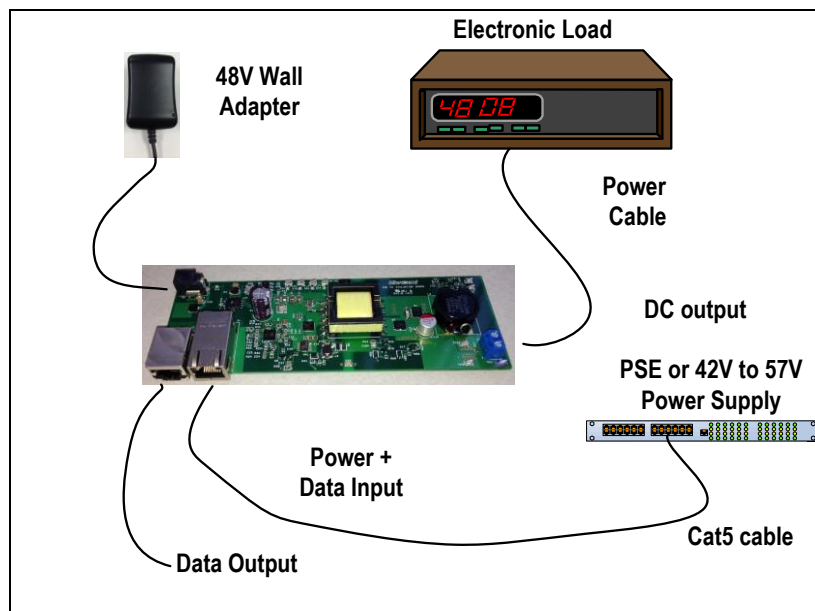

Figure 6: Test Setup

6 Test Data

This chapter describes EVB test data under various loads and POE input voltage levels. The efficiency is indicated up to 50W output power.

- Efficiency is measured at the input to the PD70224. It does not contain the RJ45 Connector or Magnetics

$$Total\ Eff = \frac{V_{out} * I_{out}}{V_{in} * I_{in}}$$

6.1 50W Efficiency vs Input Voltage to the PD70224

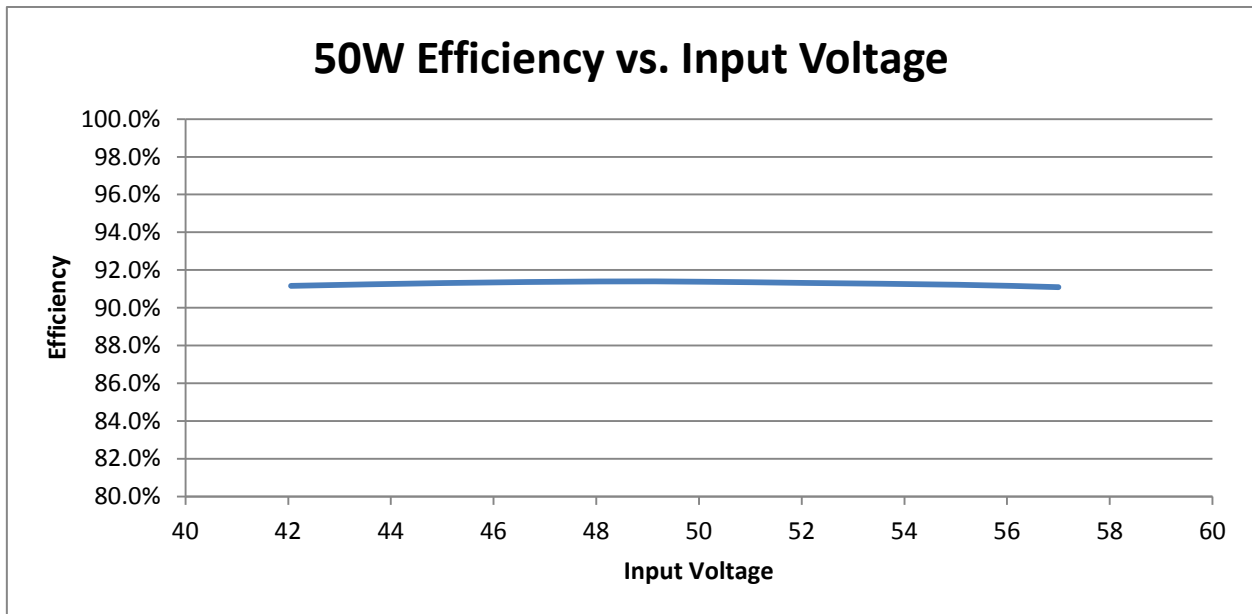

Figure 7: Efficiency vs Input Voltage



6.2 Efficiency vs. Load Current at 48V Input to the PD70224

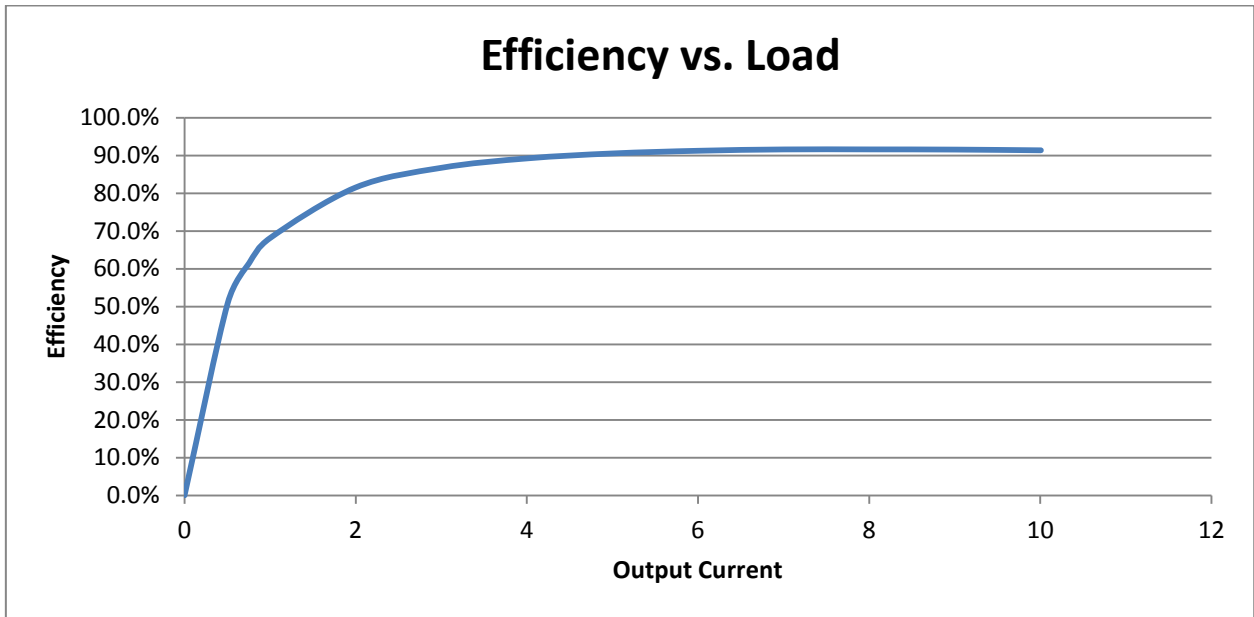

Figure 8: Efficiency at 48V Input

6.3 Load Regulation

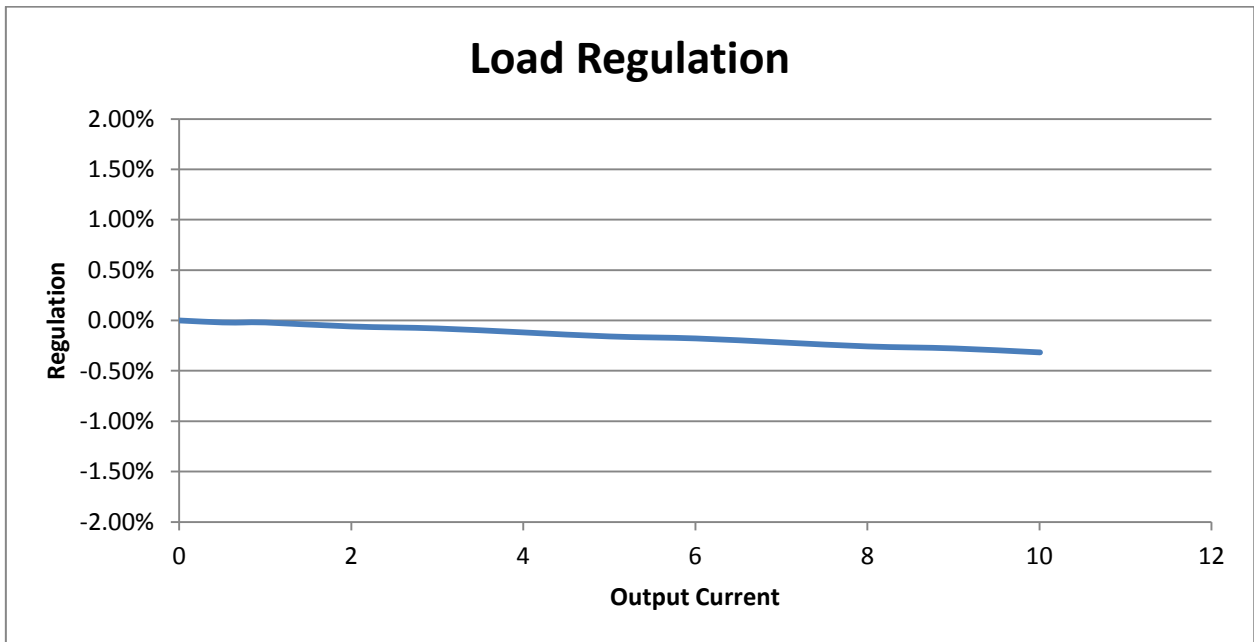

Figure 9: Load Regulation at 48V Input



Microsemi

6.4 Output Ripple

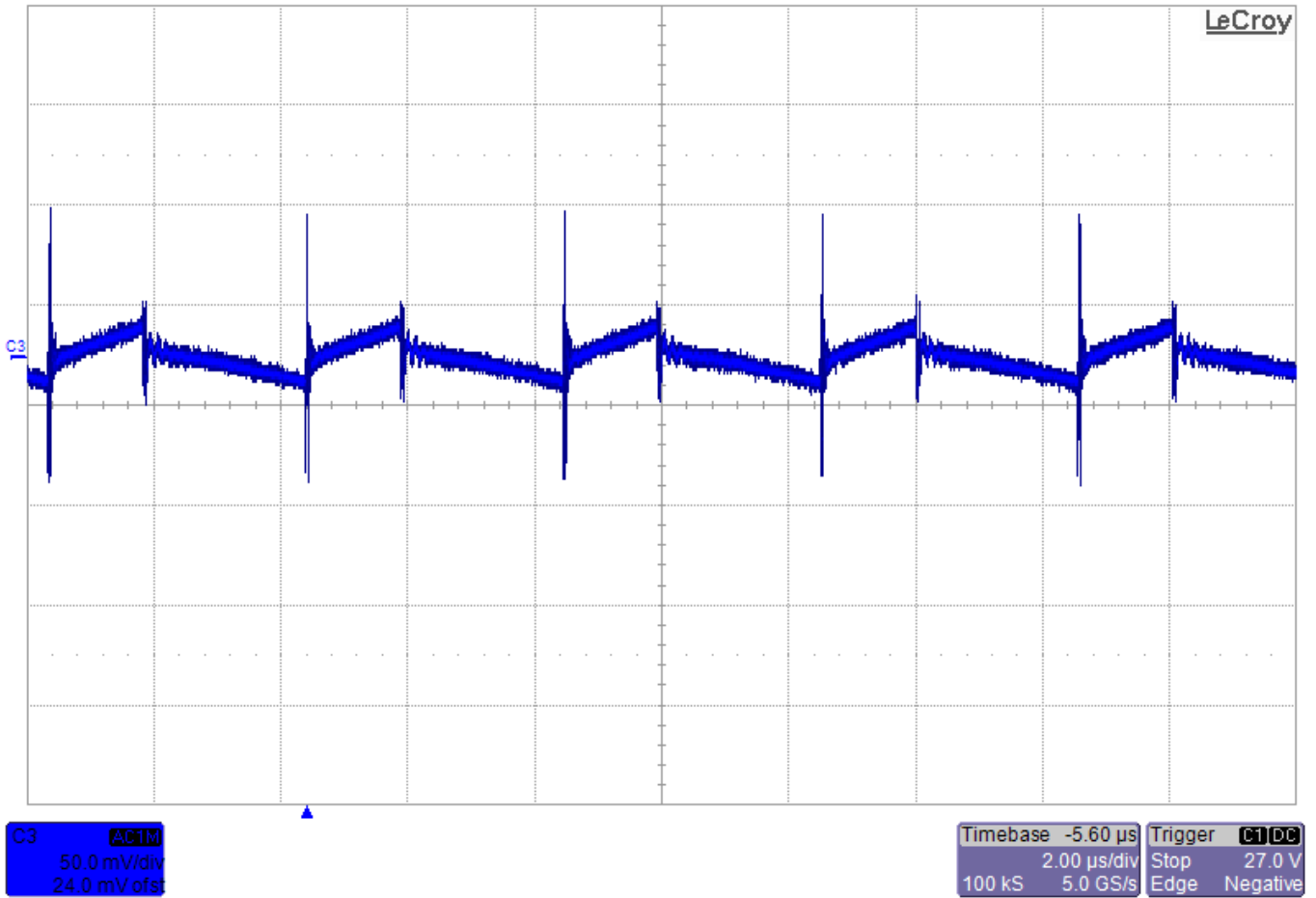
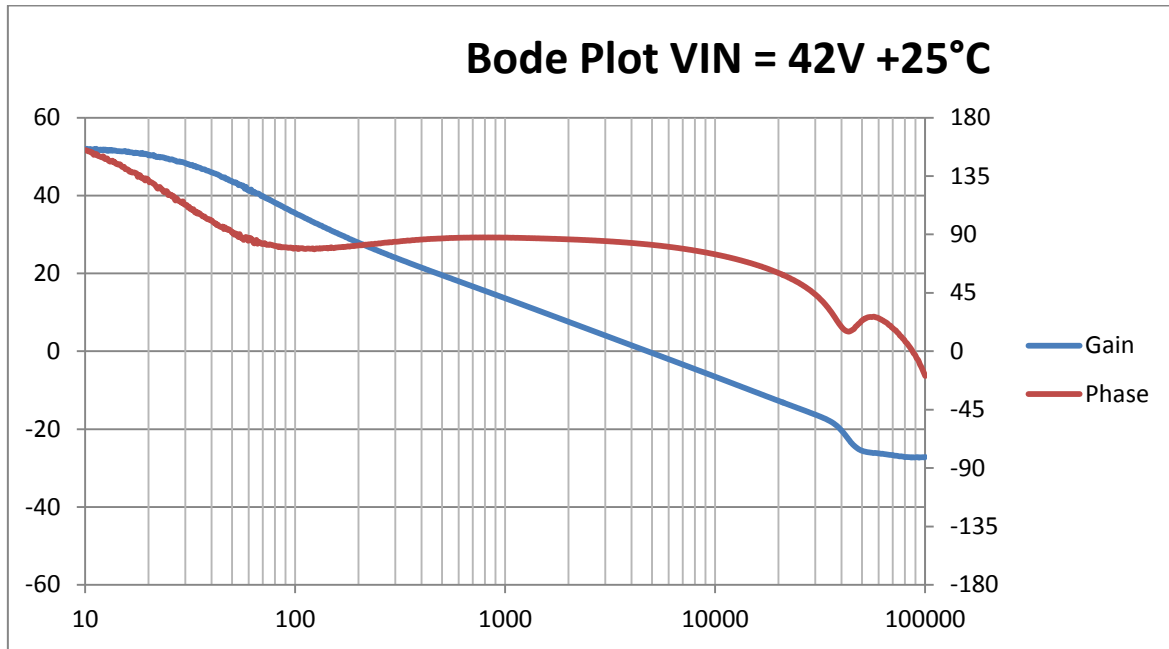

Figure 10: Full Load Voltage Ripple and Noise at 42V Input



Microsemi

6.5 Bode Plots



Bandwidth: 4731 Hz
Phase Margin: 82°
Gain Margin: -28 dB

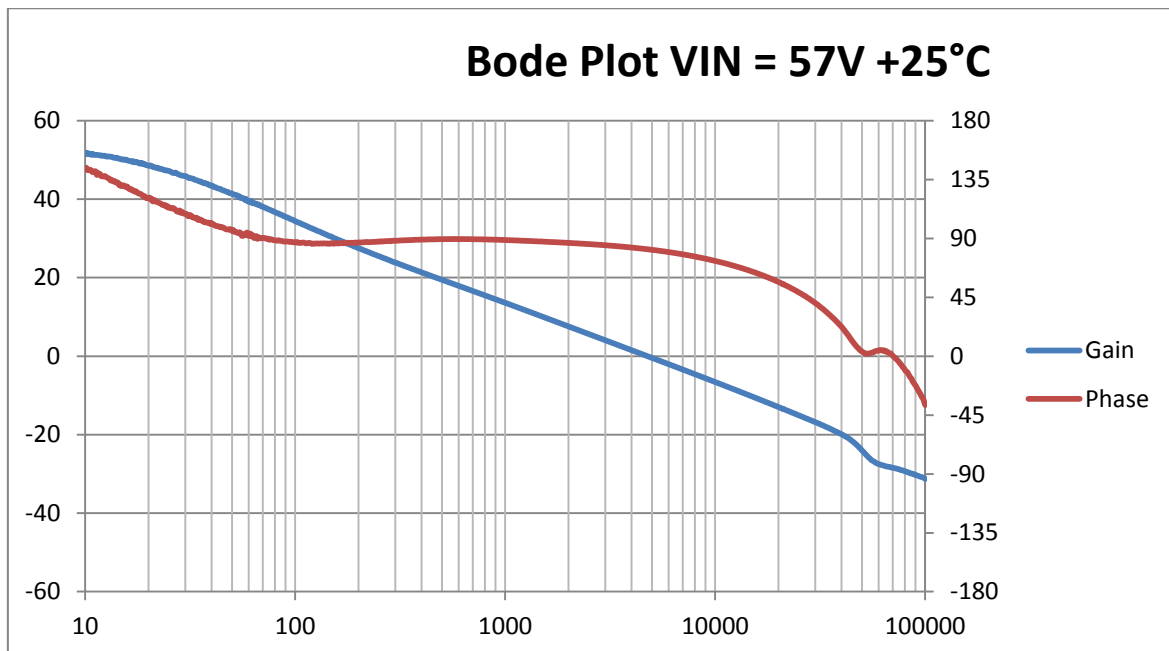

Bandwidth: 4731 Hz
Phase Margin: 82°



Microsemi®

Gain Margin: -28 dB

6.6 Step Load Response

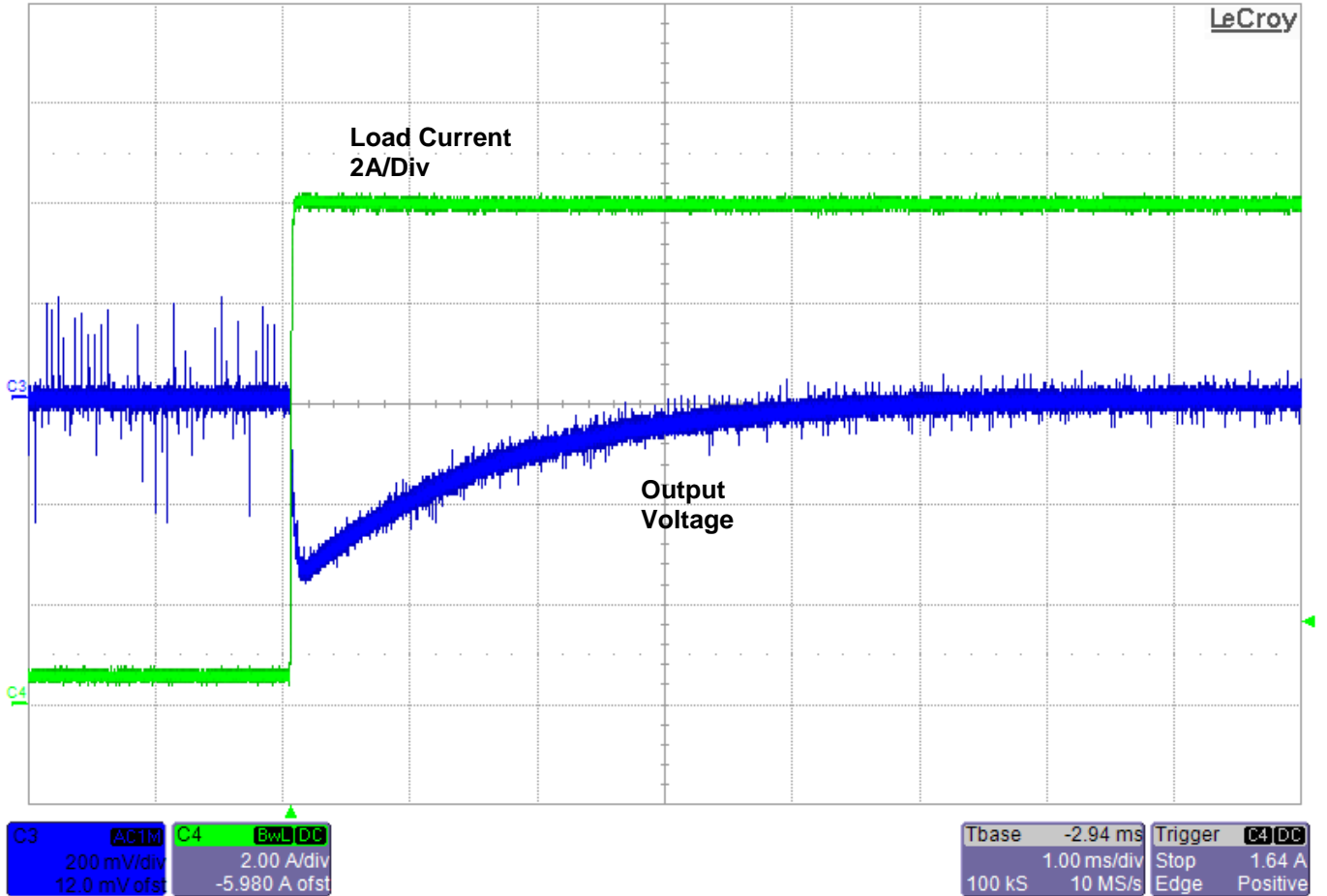

Figure 11: Load Step Response



Microsemi®

PD70211EVB50FW-5

50W Isolated Forward Converter PD
Evaluation Board

7 Schematic

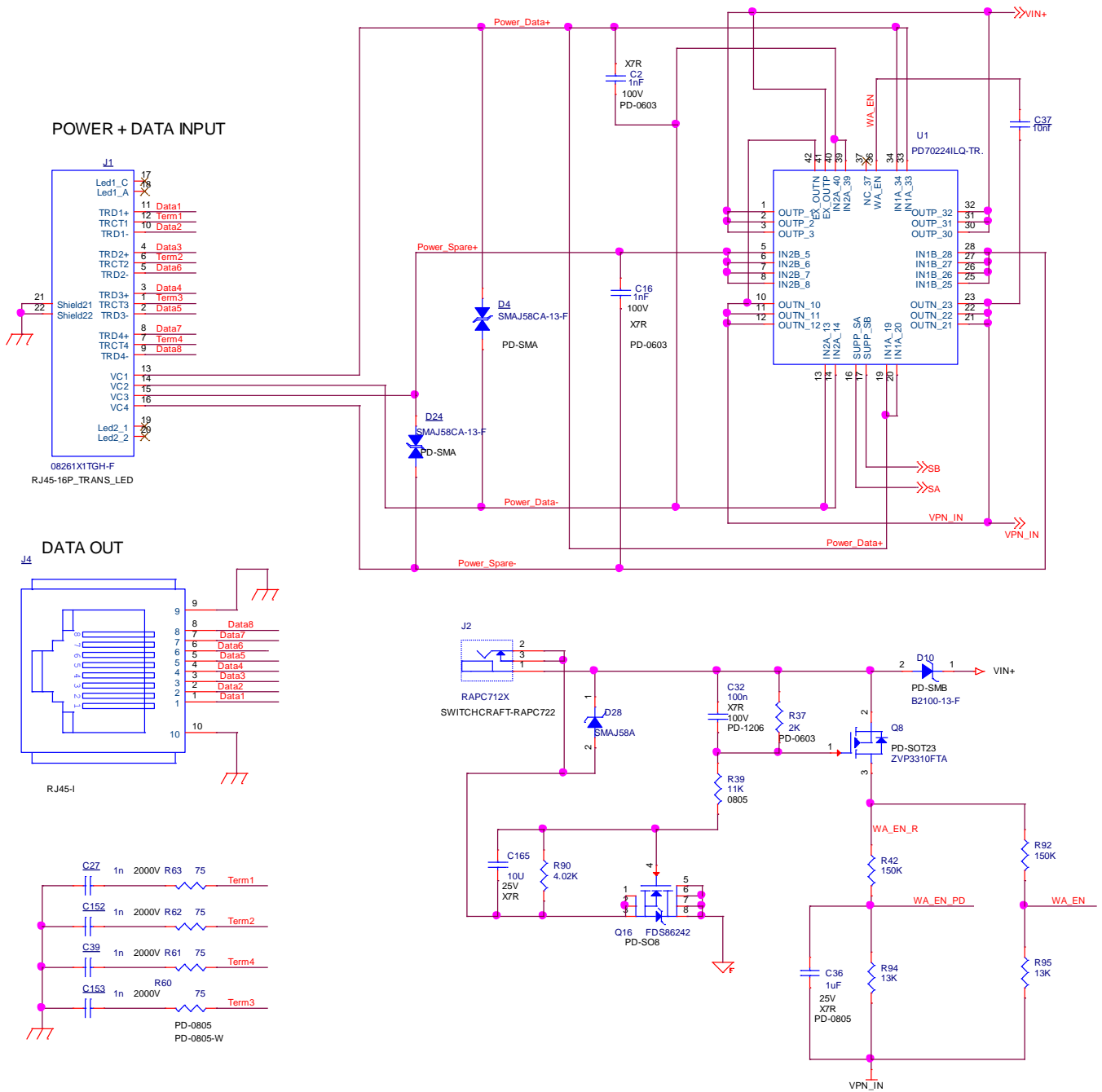

Figure 12: Evaluation Board Schematic (1 of 2)

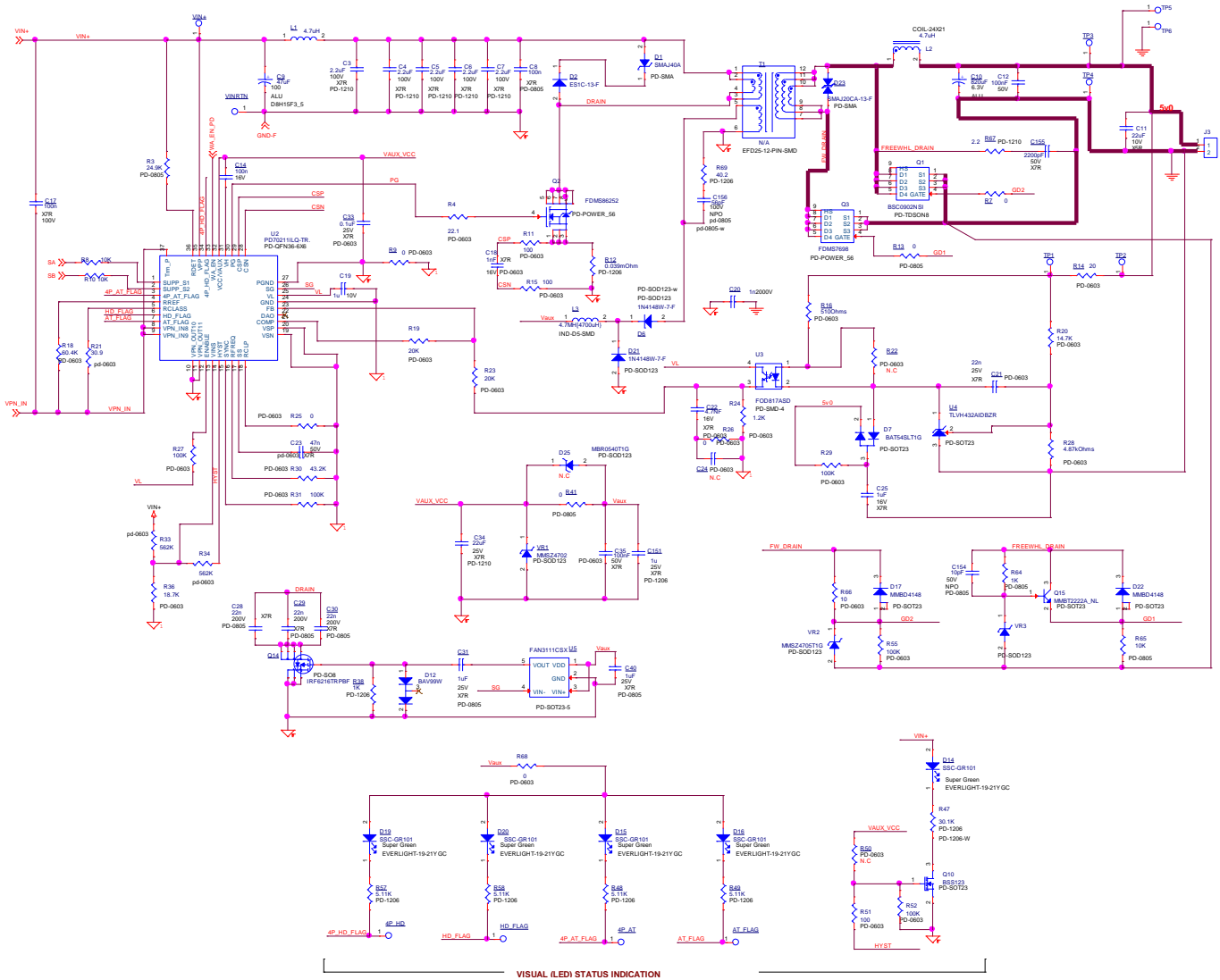

Figure 13: Evaluation Board Schematic (2 of 2)

8 List of Materials

Qty	Ref Des	Part Value	Description	Mfr. Name	Mfr. Part Number
2	C2,C16	1nF	CAP CRM 100nF 100V 10% [^] X7R 603 SMT	Any	Any
5	C3,C4, C5,C6, C7	2.2uF	CAP CER 2.2UF 100V 10% X7R 1210	Taiyo Yuden	HMK325B7225KN-T
1	C8	100n	CAP CER 0.1UF 100V 10% X7R 0805	TDK	C2012X7R2A104K12 5AA
1	C9	47uF	CAP ALUM 47UF 100V 20% RADIAL	Nichicon	UPW2A470MPD
1	C10	820uF	CAP ALUM 820UF 6.3V 20% RADIAL	Nichicon	RL80J821MDN1KX
2	C11,C12	100n	Capacitor, Ceramic, 50V, X7R, 0603	Any	Any
2	C14,C40	100n	Capacitor, Ceramic, 10V, X7R, 0805	Any	Any
2	C17,C32	100nF	CAP CRM 100nF 100V 10% [^] X7R 1206 SMT	Any	Any
1	C18	1nF	Capacitor, Ceramic, X7R, 16V, 0603	Any	Any
1	C19	1uF	Capacitor, Ceramic, 10V, X7R, 0805	Any	Any
5	C20,C27, C39, C152, C153	1nF	CAP CRM 1nF/2000V 10% X7R 1206 SMT	AVX	1206GC102KAT1A
1	C21	0.1uF	Capacitor, X7R, 10V, 10% 0603	Any	Any
1	C22	4.7n	Capacitor, Ceramic, 10V, X7R, 0603	Any	Any
1	C23	47n	Capacitor, X7R, 25V, 10% 0603	Any	Any
1	C24	TBD	Capacitor, X7R, 10V, 10% 0603	Any	Any
1	C25	1uF	CAP CER 1UF 16V 10% X7R 0805	Any	Any
1	C28	22nF	CAP CER 0.022UF 200V 10% X7R 0805	Any	Any
1	C31	1uF	CAP CER 1UF 25V 10% X7R 0805	Any	Any
2	C33,C36	100n	Capacitor, Ceramic, 25V, X7R, 0603	Any	Any
1	C34	22u	Capacitor, Ceramic, 25V, X7R, 1210	Any	Any
1	C35	100n	CAP CER 0.1UF 100V 10% X7R 0603	Any	Any
2	C36, C151	1u	CAP CRM 1uF 25V 10% X7R1206	Any	Any
1	C37	10nF	Capacitor, Ceramic, 100V 10% X7R 0603	Any	Any
1	C154	10pF	CAP CRM 10pF 50V 10% X7R 0805 SMT	Any	Any
1	C155	2200pF	Capacitor, Ceramic, 50V, X7R, 1206	Any	Any



Qty	Ref Des	Part Value	Description	Mfr. Name	Mfr. Part Number
1	C165	10uF	Capacitor, X7R, 10uF, 25V, 20% 1210	Murata	GRM32DR71E106MA12L
1	D1	1SMAJ40A	TVS DIODE 40VWM 64.5VC SMA	Diodes Inc	SMAJ40A-13-F
1	D2	ES1C	DIO FAST SWI 150V, 1A	Fairchild	ES1C
2	D4,D24	1SMA58AT3G	TVS DIODE 58VWM 93.6VC SMA	Diodes Inc	SMAJ58CA-13-F
2	D6,D21	BAT41ZFILM	DIODE SCHOTTKY 100V 0.2A SOD123	STMicroelectronics	BAT41ZFILM
1	D7	BAT54SLT1G	DIODE SCHOTTKY 30V 200MA SOT23	On Semiconductor	BAT54SLT1G
1	D10	B2100	DIODE SCHOTTKY 100V 2A SMB	Diodes Inc	B2100-13-F
3	D12,D17,D22	MMBD4148	DIODE SML SIG 100V 0.2A SOT23-3	Fairchild	MMBD4148
1	D23	SMAJ20CA	TVS DIODE 20VWM 32.4VC SMA	Diodes Inc	SMAJ20CA-13-F
5	D14,D15,D16,D19,D20	LTST-C193KGKT-5A	LED GREEN RECT CLEAR 0603	LITE-ON	LTST-C193KGKT-5A
1	J1	MagJack	CONN MAGJACK 1PORT 1000 BASE-T	Bel Stewart	8261X1TGH-F
1	J2	RAPC722X	DC Power Jack 16V 5A TH	Switchcraft	RAPC722X
1	J3	ED500/2DS	TERMINAL BLOCK 5MM 2POS PCB	On Shore Technology	ED500/2DS
1	J4	3060115907	CON RJ45 SINGLE 8 POS. SHIELDED	Kinsun	3060115907
1	L1	4.7uH	FIXED IND 4.7UH 5.5A 40 MOHM SMD	Vishay	IHLP2525CZER4R7M01
1	L2	4.7uH	FIXED IND 4.7UH 16.8A 4.5 MOHM	Pulse	PB2020.472NL
1	L3	4.7mH	FIXED IND 4.7MH 40MA 48 OHM SMD	Bourns	SDR0503-472JL
1	Q1	BSC0902NSI	MOSFET N-CH 30V 100A 8TDSON	Infineon Technologies	BSC0902NSI
1	Q2	FDMS86252	MOSFET N-CH 150V 16A POWER 56	Fairchild	FDMC86252
1	Q3	FDMS7698	MOSFET N-CH 30V 13.5A POWER56	Fairchild	FDMS7698
1	Q8	ZVP3310FTA	MOSFET P-CH 100V 75MA SOT23-3	Diodes Inc	ZVP3310FTA
1	Q9	PZTA06	TRANSISTOR GP NPN 80V SOT-223	Fairchild	PZTA06
1	Q10	BSS123	MOSFET N-CH 100V 170MA SOT-23	Fairchild	BSS123
1	Q14	IRF6216	MOSFET P-CH 150V 2.2A 8-SOIC	International Rectifier	IRF6216TRPBF
1	Q15	MMBT2222A	TRANS NPN 40V 0.6A SMD SOT23-3	Diodes Inc	MMBT2222A-7-F



Qty	Ref Des	Part Value	Description	Mfr. Name	Mfr. Part Number
1	Q16	FDS86242	N-CH POWER MOSFET 150v 4.1A SO8	Fairchild	FDS86242
1	R3	24.9K	Resistor, 1%, 1/10W, 0805	Any	Any
1	R4	2.7	Resistor, 5%, 1/10W, 0603	Any	Any
4	R7,R13, R25,R26	0	Resistor, 5%, 1/10W, 0603	Any	Any
2	R8,R10	10K	Resistor, 1%, 1/16W, 0603	Any	Any
1	R9	0	Resistor, 1%, 1/16W, 0603	Any	Any
2	R11,R15	100	Resistor, 1%, 1/16W, 0603	Any	Any
1	R12	0.043	RES SMD 0.043 OHM 1% 1/2W 1206	TE Connectivity	1-2176055-6
1	R14	20	Resistor, 5%, 1/10W, 0603	Any	Any
1	R16	510	Resistor, 5%, 1/10W, 0603	Any	Any
1	R18	60.4K	Resistor, 60.4K Ohms, 1/16 Watt, 1% 0603 Type SMD	Any	Any
2	R19,R23	20K	Resistor, 5%, 1/10W, 0603	Any	Any
1	R20	14.7K	Resistor, 1%, 1/16W, 0603	Any	Any
1	R21	30.9	Resistor, 30.9 Ohms, 1/16 Watt, 1% 0603 Type SMD	Any	Any
2	R22,R50	NC	Resistor, 5%, 1/10W, 0603	Any	Any
1	R24	1.2k	Resistor, 5%, 1/10W, 0603	Any	Any
6	R27,R29, R31,R45, R52,R55	100K	Resistor, 5%, 1/10W, 0603	Any	Any
1	R28	4.87K	Resistor, 1%, 1/16W, 0603	Any	Any
1	R30	43.2k	Resistor, 1%, 1/16W, 0603	Any	Any
1	R33	562K	Resistor, 1%, 1/10W, 0805	Any	Any
1	R34	562K	Resistor, 1%, 1/16W, 0603	Any	Any
1	R36	18.7K	Resistor, 1%, 1/16W, 0603	Any	Any
1	R37	2.00k	Resistor, 5%, 1/10W, 0603	Any	Any
1	R38	1K	Resistor, 1K Ohms, 1/4 Watt, 5% 1206 Type SMD	Any	Any
1	R39	11K	RES 11K 250 mW 1% 1206 SMT MTL FLM	Any	Any



Qty	Ref Des	Part Value	Description	Mfr. Name	Mfr. Part Number
1	R40	2.2k	Resistor, 5%, 1/4W, 1206	Any	Any
1	R41	0	Resistor, 5%, 1/10W, 0805 SMD	Any	Any
2	R42, R92	150K	RES 150K 250 mW 1% 1206 SMT MTL FLM	Any	Any
1	R43	1k	Resistor, 5%, 1/10W, 0603	Any	Any
1	R44	820	Resistor, 1%, 1/16W, 0603	Any	Any
1	R46	620	Resistor, 1%, 1/16W, 0603	Any	Any
1	R47	20K	RES TK FLM 20K 250mW 1%1206	Any	Any
2	R48,R57	5.6k	Resistor, 5%, 1/4W, 1206	Any	Any
2	R49,R58	5.6k	Resistor, 5%, 1/4W,1206	Any	Any
1	R51	100	Resistor, 5%, 1/10W, 0603	Any	Any
4	R60,R61, R62,R63	75	Resistor, 1%, 1/10W, 0805	Any	Any
1	R42	15.0K	Resistor, 1%, 1/4W, 1206	Any	Any
1	R43	1k	Resistor, 5%, 1/10W, 0603	Any	Any
1	R44	820	Resistor, 1%, 1/16W, 0603	Any	Any
1	R46	620	Resistor, 1%, 1/16W, 0603	Any	Any
1	R47	20K	RES TK FLM 20K 250mW 1%1206	Any	Any
2	R48,R57	5.6k	Resistor, 5%, 1/4W, 1206	Any	Any
2	R49,R58	5.6k	Resistor, 5%, 1/4W,1206	Any	Any
1	R51	100	Resistor, 5%, 1/10W, 0603	Any	Any
4	R60,R61, R62,R63	75	Resistor, 1%, 1/10W, 0805	Any	Any
1	R64	1K	Resistor, 5%, 1/8W, 0805	Any	Any
1	R65	10K	Resistor, 5%, 1/10W, 0603	Any	Any
1	R66	10	Resistor, 5%, 1/10W, 0603	Any	Any
1	R67	2.7	Resistor, 5%, 1/2W, 1210	Any	Any
1	R90	4.02k	Resistor, 4.02K, 1%, 1/16W 0603	Any	Any
2	R94, R95	13k	Resistor, 13K, 1%, 1/16W 0603	Any	Any



PD70211EVB50FW-5

50W Isolated Forward Converter PD Evaluation Board

Microsemi

Qty	Ref Des	Part Value	Description	Mfr. Name	Mfr. Part Number
5	TP1,TP2, TP3,TP4, VIN+	5015	Terminal, miniature style test point, SMT PCB Mount	Keystone	5015
4	4P_HD,4P_ AT, HD_FLAG, AT_FLAG	5015	TEST POINT PC MINIATURE SMT	Keystone	5015
1	T1	5V 50W	5V 50W Transformer, EFD25, SMD 12 Terminal	TMP DongGuan	DG-EFD25-0005 GP
			alternate	ICE Components	TX15060
			alternate	Shinohm	STEF25-004
1	U1	PD70224	IC, Ideal Diode Bridge	Microsemi	PD70224ILQ
1	U2	PD70211	IC, Power Over Ethernet PD Controller	Microsemi	PD70211ILQ
1	U3	FOD817A	OPTOCOUPLER TRANS 5KVRMS 4SMD	Fairchild	FOD817AS
1	U4	TLV431	IC VREF SHUNT PREC ADJ SOT-23-3	Texas Instruments	TLV431AIDBZR
1	U5	FAN3111C	IC GATE DVR SGL 1A EXTER SOT23-5	Fairchild	FAN3111CSX
1	VINRTN	5016	Terminal, Compact style test point, SMT PCB Mount	Keystone	5016
1	VR1	BZT52C15	DIODE ZENER 15V 500MW SOD123	Diodes, Inc	BZT52C15-7-F
1	VR2	BZT52C18	DIODE ZENER 18V 500MW SOD123	Diodes, Inc	BZT52C18-7-F
1	VR3	BZT52C12	DIODE ZENER 12V 500MW SOD123	Diodes, Inc	BZT52C12-7-F

9 Board Layout

This section presents the layout of the evaluation board. The board is a 4 layer board. All layers are 2 Oz layers. Below figures present the 4 copper layers and the silk of the board for tracking devices placements.

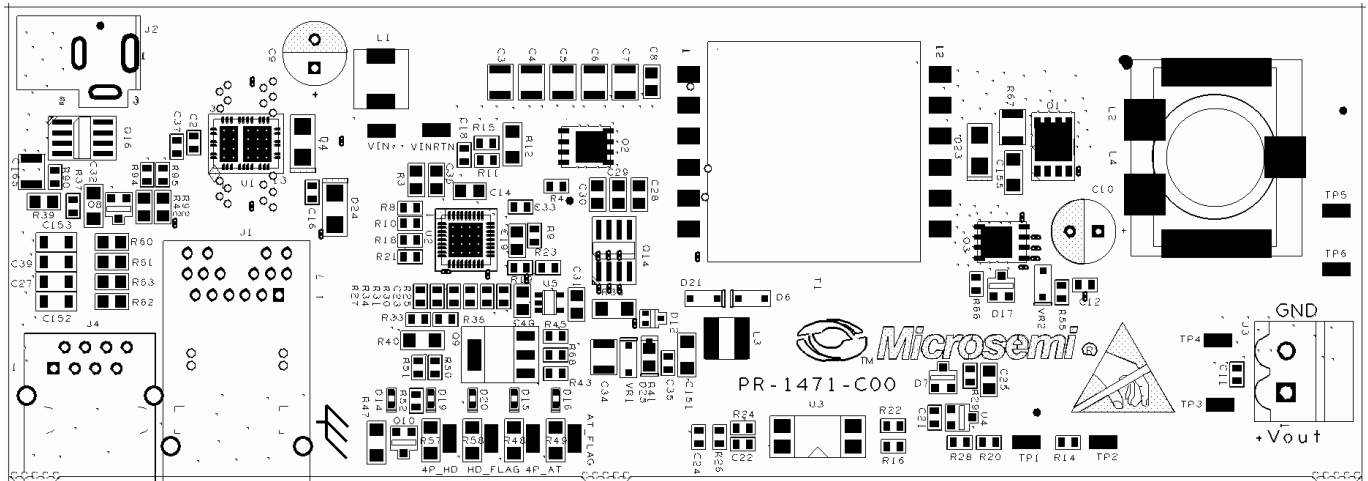

Figure 14: Top Silk and Solder Mask

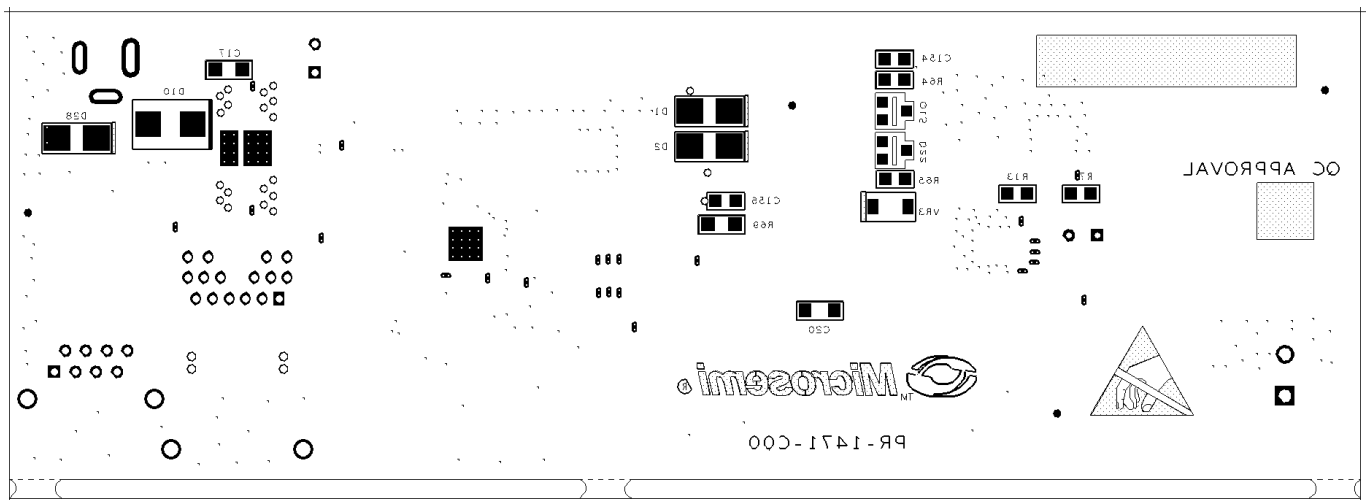

Figure 15: Bottom Silk and Solder Mask

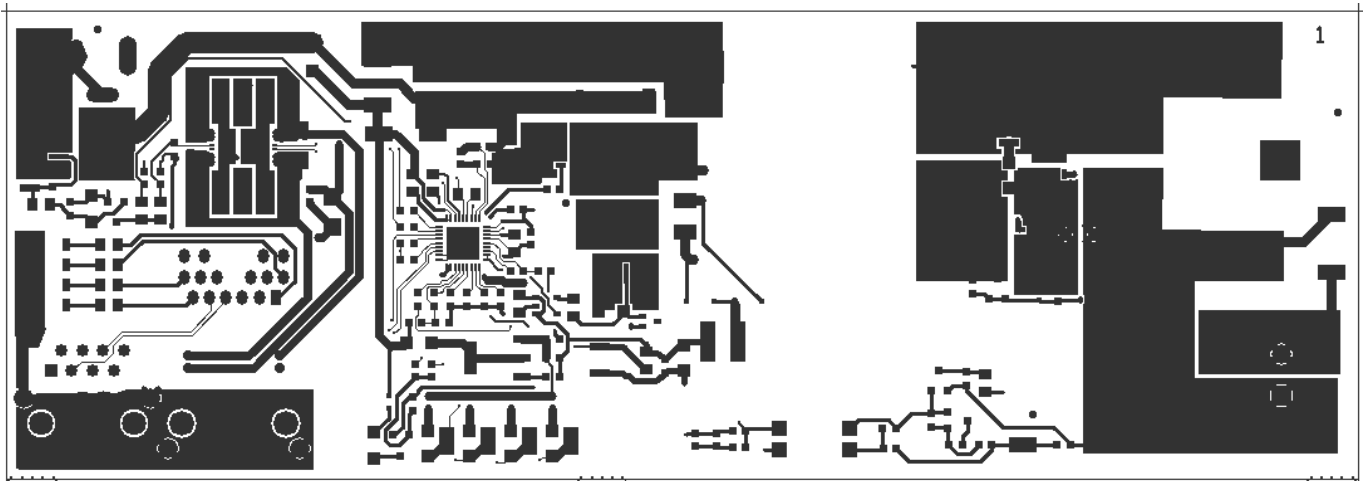

Figure 16: Top Layer

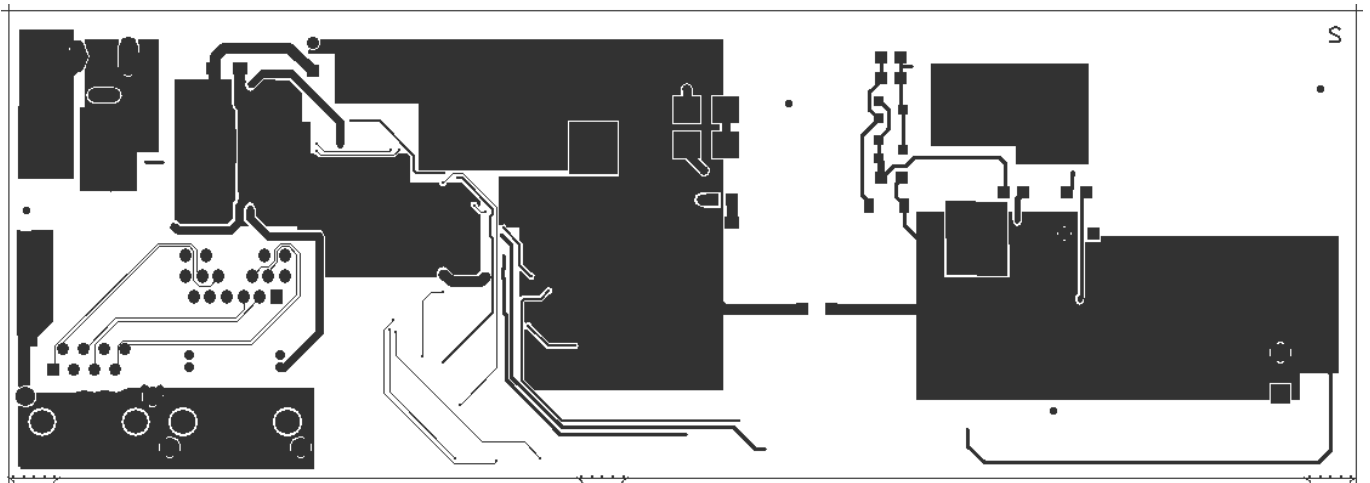

Figure 17: Bottom layer



The information contained in the document (unless it is publicly available on the Web without access restrictions) is PROPRIETARY AND CONFIDENTIAL information of Microsemi and cannot be copied, published, uploaded, posted, transmitted, distributed or disclosed or used without the express duly signed written consent of Microsemi. If the recipient of this document has entered into a disclosure agreement with Microsemi, then the terms of such Agreement will also apply. This document and the information contained herein may not be modified, by any person other than authorized personnel of Microsemi. No license under any patent, copyright, trade secret or other intellectual property right is granted to or conferred upon you by disclosure or delivery of the information, either expressly, by implication, inducement, estoppels or otherwise. Any license under such intellectual property rights must be approved by Microsemi in writing signed by an officer of Microsemi.

Microsemi reserves the right to change the configuration, functionality and performance of its products at any time without any notice. This product has been subject to limited testing and should not be used in conjunction with life-support or other mission-critical equipment or applications. Microsemi assumes no liability whatsoever, and Microsemi disclaims any express or implied warranty, relating to sale and/or use of Microsemi products including liability or warranties relating to fitness for a particular purpose, merchantability, or infringement of any patent, copyright or other intellectual property right. Any performance specifications believed to be reliable but are not verified and customer or user must conduct and complete all performance and other testing of this product as well as any user or customers final application. User or customer shall not rely on any data and performance specifications or parameters provided by Microsemi. It is the customer's and user's responsibility to independently determine suitability of any Microsemi product and to test and verify the same. The information contained herein is provided "AS IS, WHERE IS" and with all faults, and the entire risk associated with such information is entirely with the User. Microsemi specifically disclaims any liability of any kind including for consequential, incidental and punitive damages as well as lost profit. The product is subject to other terms and conditions which can be located on the web at <http://www.microsemi.com/company/terms-and-conditions>

Revision History

Revision Level / Date	Para. Affected/Page	Description
1.0 / 1-May-15		Initial revision
2.0 / 29-June-16	Par.7-9	Updated schematic, BOM and board layout

© 2015 Microsemi Corp.

All rights reserved.

For support contact: PoEsupport@microsemi.com

Visit our web site at: www.microsemi.com

Catalog Number: PD70211EVB50FW-5_UG_EVB

X-ON Electronics

Largest Supplier of Electrical and Electronic Components

Click to view similar products for [Ethernet Development Tools](#) category:

Click to view products by [Microchip](#) manufacturer:

Other Similar products are found below :

[XAUI-RISER-B](#) [KSZ8081RNB-EVAL](#) [KSZ8863FLL-EVAL](#) [KSZ8873MLL-EVAL](#) [PD-IM-7648M](#) [PD-IM-7648T4](#) [EV09H26A](#) [EV44F42A](#)
[EVAL-ADIN1200FMCZ](#) [DP83620-EVK/NOPB](#) [WIZ550S2E-232-EVB](#) [DFR0272](#) [A000024](#) [DFR0125](#) [UKIT-006GP](#) [UKIT-003FE](#) [UKIT-](#)
[002GB](#) [UKIT-001FE](#) [EVB-KSZ9477](#) [OM-E-ETH](#) [DP83867ERGZ-R-EVM](#) [UP-POE-A20-0001](#) [2971](#) [3785](#) [EVAL-CN0506-FMCZ](#)
[ASX00006](#) [ASX00021](#) [ASX00026](#) [XTIB-E](#) [ESP32-ETHERNET-KIT-VE](#) [EVB-KSZ9897-1](#) [KSZ9031MNX-EVAL](#) [AC164121](#) [AC164132](#)
[AC320004-5](#) [DM320114](#) [DM990004](#) [EV02N47A](#) [EV44C93A](#) [EVB8740](#) [EVB-KSZ8563](#) [EVB-KSZ9477-1](#) [EVB-LAN7430](#) [EVB-](#)
[LAN7431-EDS](#) [EVB-LAN7800LC-1](#) [EVB-LAN7850](#) [EVB-LAN9252-3PORT](#) [EVB-LAN9252-ADD-ON](#) [EVB-LAN9252-DIGIO](#) [EVB-](#)
[LAN9252-HBIPLUS](#)