



**PD70224 & PD70210/A EVB**  
**Ideal Diode Bridge**  
**Evaluation Board User Guide**

Revision 2.0

**PRODUCTION DATA** – Information contained in this document is proprietary to Microsemi and is current as of publication date. This document may not be modified in any way without the express written consent of Microsemi. Product processing does not necessarily include testing of all parameters. Microsemi reserves the right to change the configuration and performance of the product and to discontinue product at any time.



## Table of Contents

<b>1</b>	<b>ABOUT THIS GUIDE.....</b>	<b>3</b>
1.1	Audience .....	3
1.2	Organization .....	3
1.3	Reference Documents .....	3
<b>2</b>	<b>INTRODUCTION.....</b>	<b>4</b>
2.1	Evaluation Boards Ordering Information.....	5
2.2	Evaluation Board Features.....	5
<b>3</b>	<b>PHYSICAL DESCRIPTION .....</b>	<b>7</b>
3.1	Physical Characteristics .....	7
3.2	Package Contents .....	7
3.3	Connectors .....	7
3.4	Indications .....	9
<b>4</b>	<b>ELECTRICAL CHARACTERISTICS .....</b>	<b>10</b>
<b>5</b>	<b>INSTALLATION.....</b>	<b>11</b>
5.1	Preliminary Considerations and Safety Precautions.....	11
5.2	Initial Configuration .....	11
<b>6</b>	<b>SCHEMATICS.....</b>	<b>12</b>
<b>7</b>	<b>LIST OF MATERIALS (PD70224 + PD70210) .....</b>	<b>15</b>
<b>8</b>	<b>LIST OF MATERIALS (PD70224 + PD70210A).....</b>	<b>16</b>
<b>9</b>	<b>BOARD LAYOUT .....</b>	<b>17</b>



# 1 About this Guide

This user guide provides both description and operation procedures for Microsemi's PD70224 & PD70210/A EVB board. This board type is used for evaluating the performance of PD70224 device which is Ideal Bridge targeted for High current PD devices.

PD70224 device supports two 1-Amp input channels received from PSE side.

This current level supports full HDBaseT power. Current from PD70224 diode bridge flows to PD70210ILQ device which is PD front end for High current applications.

PD70210/A device supports HDBaseT standard PD application or twice IEEE802.3at standard PD application. The board supports a 95 Watt output at the received voltage level.

## 1.1 Audience

This user guide is intended for qualified personnel, that is, operators and technicians who have a background in basic concepts of electronics.

## 1.2 Organization

This guide is arranged according to the following:

- Chapter 1 **About this Guide:** Describes the objectives, audience, and organization.
- Chapter 2 **Introduction:** Provides an overview about evaluation board's main functions, features, physical characteristics, and ordering information.
- Chapter 3 **Physical Description:** Provides explanation related to the physical description (switches, jumpers, connectors).
- Chapter 4 **Electrical Characteristics:** Provides electrical characteristics of the evaluation board.
- Chapter 5 **Installation:** Provides a description of the installation process.
- Chapter 6 **Schematics:** Provides a board schematic diagram.
- Chapter 7 **List of Materials (PD70224 + PD70210):** Provides the board's list of materials.
- Chapter 8 **List of Materials (PD70224 + PD70210A):** Provides the board's list of materials.
- Chapter 9 **Board Layout:** Provides board Gerber files description for all layers.

## 1.3 Reference Documents

PD70224 datasheet, catalog number DS\_PD70224

PD70210/A datasheet, catalog number DS\_PD70210\_PD70210A

## 2 Introduction

Microsemi’s PD70224EVB Evaluation Board (see Figure 2) provides designers with the environment needed for evaluating the performance and implementation of PD applications based on PD70224 and PD70210/A devices.

The board uses a single PD device, PD70210ILD or PD70210AILD, to support the Detection, Class, and Power Supplying phases on the 2/4 Pairs of the Cat5 cable. Both versions support a standard Twin HDBaseT interface and compatible to IEEE802.3AT Type 2 interface. The version with PD70210A has wall adapter pin (WA\_EN) for adapter priority. The version with PD70210ILD has instead Power Good signal.

All necessary steps and connection instructions required for installing and operating this board are provided within this document.

Microsemi’s PD70210/A device is part of a family of devices which are targeted for realizing the HDBaseT or multi 802.3at standard PD interface.

High power PD interface devices family includes the following:

Device type	Power Capability	Integrates PWM Controller
PD70210ILD	Twin HDBaseT ports	No
PD70210AILD	Twin HDBaseT ports supporting Wall adapter priority	No
PD70211ILQ	Twin HDBaseT ports supporting Wall adapter connection	Yes
PD70224ILQ	Ideal diode bridge	N/A

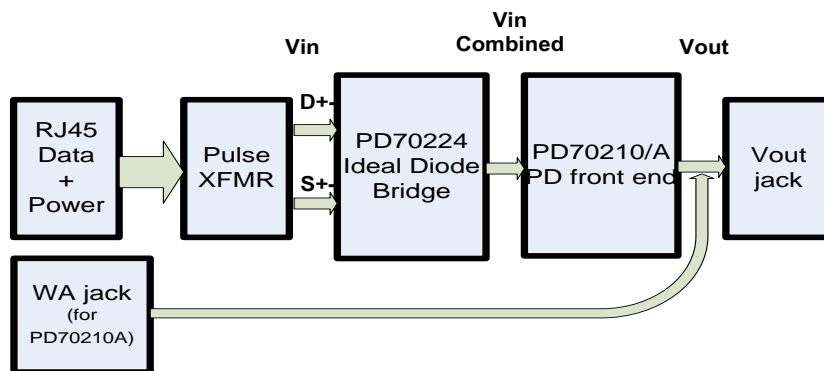

Figure 1: PD70224EVB Block Diagram



Figure 2: PD70224EVB / PD70210 Evaluation Board – General View

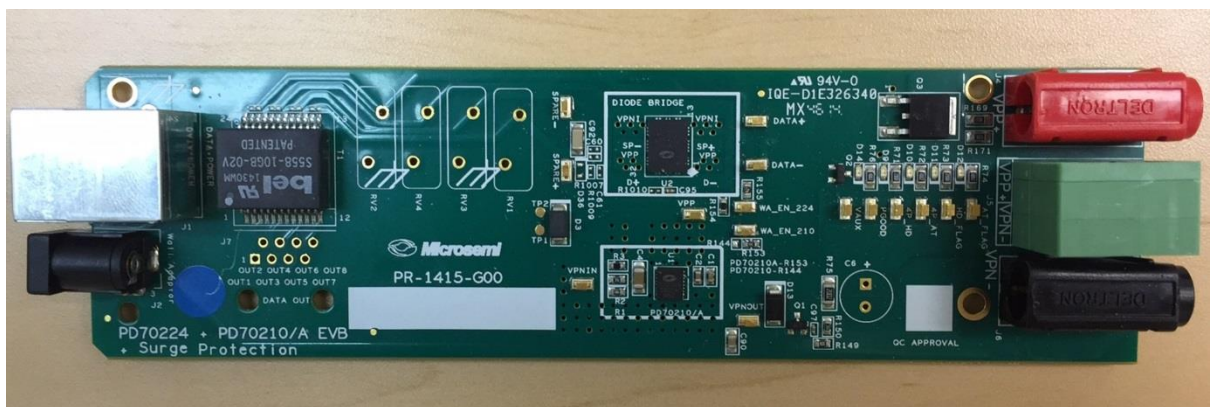

Figure 3: PD70224EVB / PD70210A Evaluation Board – General View

## 2.1 Evaluation Boards Ordering Information

Microsemi supplies the following Evaluation Boards:

Ordering Number	Description
PD70224 + PD70210 EVB	Dual IEEE802.3AT Type 2 PD/ Twin HDBaseT board, based on PD70210 device. Using PD70224 Ideal diode bridge
PD70224 + PD70210A EVB	Dual IEEE802.3AT Type 2 PD/ Twin HDBaseT board, based on PD70210A device. Using PD70224 Ideal diode bridge

## 2.2 Evaluation Board Features

- Designed to support Data and Spare current using a single PD70210/A device
- Data and Power in RJ45 connector
- Output voltage connector
- Wall adapter connector (on PD70210A version)
- On board Power Good LED indicator (on PD70210 version)
- On board AT detected LED indicator
- On board 4P\_AT detected LED indicator
- On board HD detected LED indicator



- On board 4P\_HD detected LED indicator
- Evaluation Board working temperature: 0° to +70°C
- RoHS compliant



## 3 Physical Description

### 3.1 Physical Characteristics

The following table lists the evaluation board's physical characteristics.

**Table 1: Physical Characteristics**

Parameter	Value
Mechanical dimensions in mm	160 x 45 x 19mm (L x W x H)

### 3.2 Package Contents

Upon opening the Evaluation Board package, verify the following part is included. If it seems damaged, contact your local representative or Microsemi's headquarters.

Package content for standard shipments is:

PD70224EVB + PD70210/A Evaluation Board

### 3.3 Connectors

The following sections provide both general and detailed information regarding unit's connectors.

#### 3.3.1 Connectors Table

Lists of the Evaluation Board's connectors.

**Table 2: Connectors List**

#	Connector	Name	Description
1	J1	RJ45 Connector	RJ45 port for Data and Power In for PSE connection
2	J5	PD device Output	Terminal blocks for connecting a load to PD output.
3	J4,J6	PD device Output	Banana Jacks for connecting a load to PD output.
4	J2	Wall adapter connector	A jack for connecting auxiliary wall adapter (on PD70210A version only)

#### 3.3.2 Connectors Detailed Explanation

The numbering is in reference to the numbers listed in the schematics.

##### 1. RJ45 Connector

There is a Data+Power dedicated RJ45 connector, See Figure 4.

**Table 3: RJ45 Connectors**

CON1 Pin No	Signal Name	Description
1, 2	Data and Power In	Data and power input to powered device (HDBaseT Master Negative data port)
3, 6	Data and Power In	Data and power input to powered device (HDBaseT Master Positive data port)

4, 5	Data and Power In	Data and power input to powered device (HDBaseT Master Positive data port)
7, 8	Data and Power In	Data and power input to powered device (HDBaseT Master Negative data port)

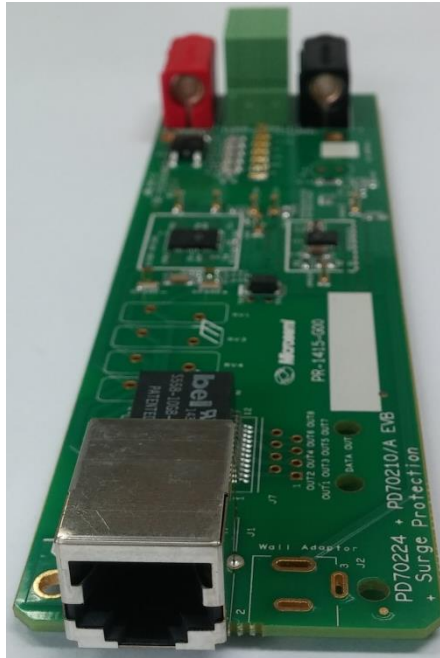

Figure 4: Front RJ45 Connector

**2. V<sub>out</sub> Connectors**

See Figure 5.

J5 – DCDC output connection, used for connecting to external load.

For easy connection, Black and Red Banana jacks are parallel to J5 connections.

**Table 4: J5 Connector (Green)**

Pin No.	Signal Name	Description
J5 (Left) – Pin 1	Vout_Rtn	Return PD received output voltage
J5 (Right) – Pin 2	Vout	Positive PD received output voltage



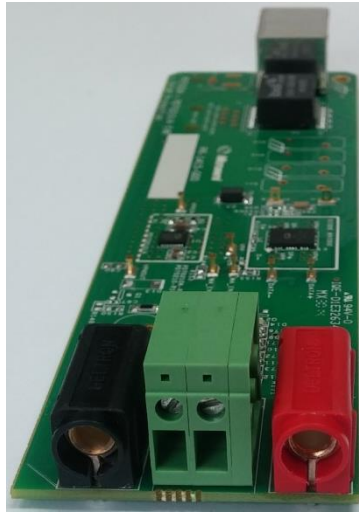

Figure 5: V<sub>out</sub> Connectors

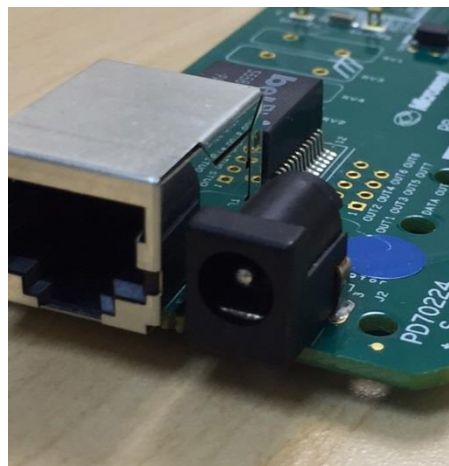

Figure 6. Wall adapter jack

### 3.4 Indications

The following sections provide general information regarding unit indications.

#### 3.4.1 LED Indication

See Figure .

D14 is the Power\_GOOD indication LED, a PD70210 device output signal indicating the device isolation switch is operated. This flag is lit in every operating state (PD70210 versions only)

D12 is the AT\_FLAG indication LED, a PD70210 device output signal indicating the device has detected a 2 finger class event from the PSE side in the class stage. The flag will be operative at 3, 4, and 6 fingers detection as well.

D10 is the 4P\_AT indication LED, a PD70210 device output signal indicating the device has detected a 4 finger class event from the PSE side in the class stage, or a 2 finger class event from the PSE side in the class stage, and both SUPP\_Sa and SUPP\_Sb are High.

The flag will be operative at 6 fingers detection as well.

D11 is the HD\_FLAG indication LED, a PD70210 device output signal indicating the device has detected a 3 finger class event from the PSE side in the class stage.

The flag will be operative at 6 fingers detection as well.

D9 is the 4P\_HD indication LED, a PD70210 device output signal indicating the device has detected a 6 finger class event from the PSE side in the class stage.

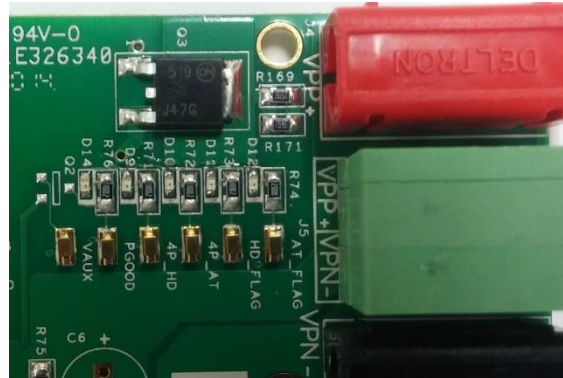

Figure 7: LED Indications

## 4 Electrical Characteristics

Evaluation board electrical characteristics are described below:

Table 5: Electrical Characteristics

Parameter	Min	Max	
RJ45 connector	42	57	V
Maximum Available Current	2		A

## 5 Installation

### 5.1 Preliminary Considerations and Safety Precautions

Verify board's power supply is turned off before all peripheral devices are connected.

**Note:** In maximum power at the output, some of the devices may reach high temperatures (still less than 70 Celsius degrees). Pay attention while testing these devices.

### 5.2 Initial Configuration

**Note:** Prior to starting any operation, it is important to verify that the Evaluation Board is setup as shown in Figure .

1. Connect a Cat5 cable from PSE to Evaluation Board (J1)
2. When there is a need to test the Ethernet data, connect Ethernet cable from Evaluation Board (CON2) to PD Ethernet Host.
3. After the PD is On, PGOOD is Lit, the load can be connected to J5.

Caution: connect the load after the PD is On

If a resistive load is connected to board output, before PGOOD is lit, then 70210 will be limiting the current and the voltage in the output will never reach the required voltage.

This may also cause a constant high power dissipation of PD70210.

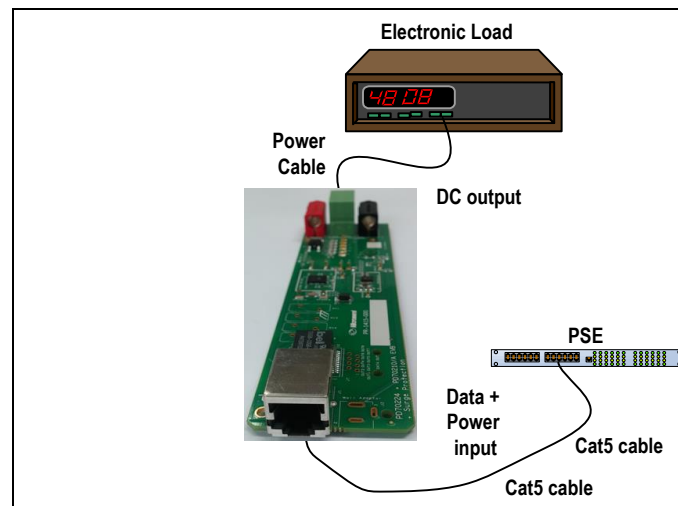

Figure 8: An example of test Setup



# 6 Schematics

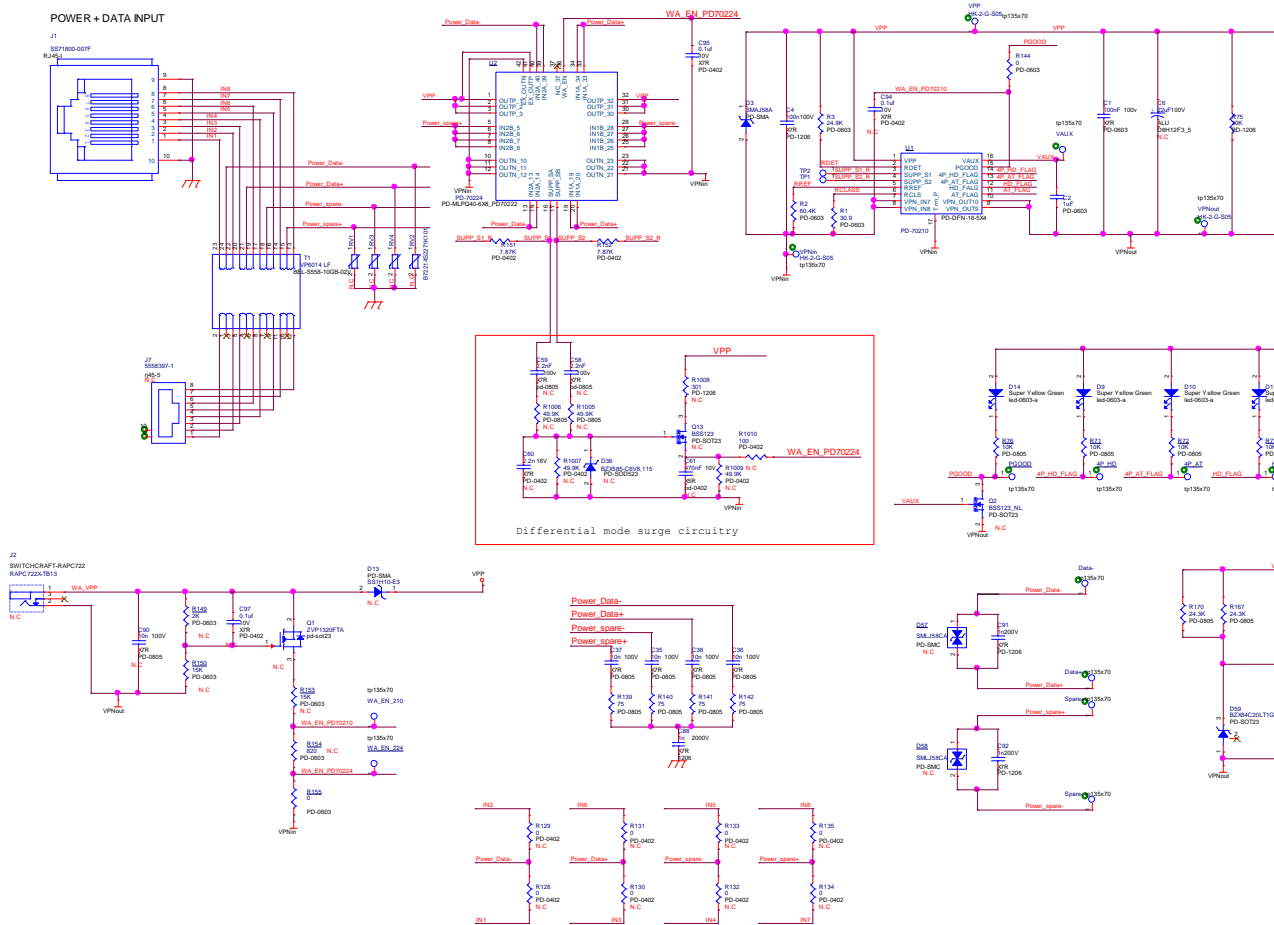

Figure 9: PD70224 + PD70210 Board Schematic



PD70224EVB Evaluation

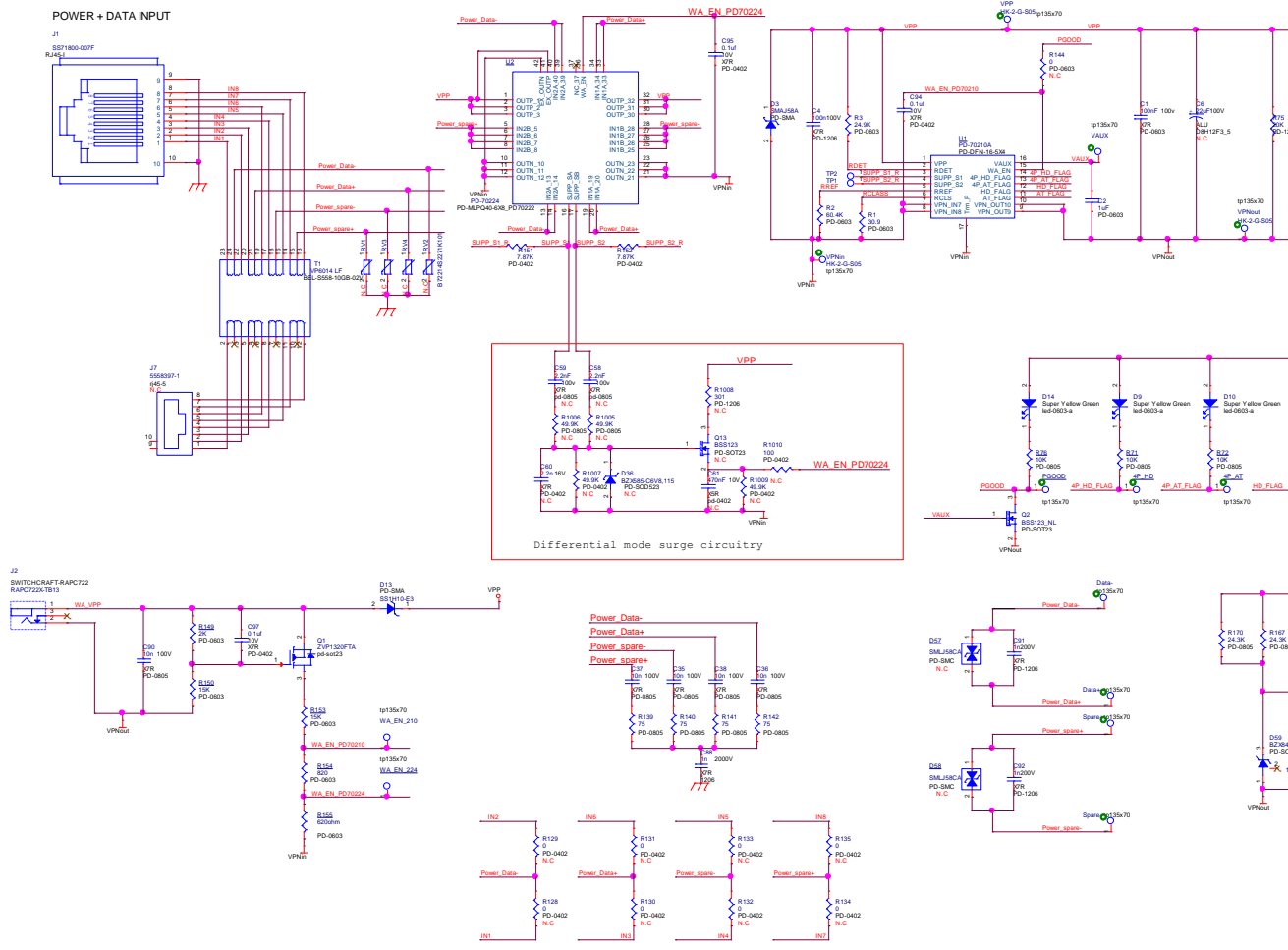

Figure 10: PD70224 + PD70210A board Schematic



**Note:** the voltage regulator that is built of Q3 D59 is not needed in real application; It exists only for evaluation purposes. of a DCDC after PD70210, and this DCDC typically have an auxiliary output voltage for converter powering. The Auxiliary This low voltage output at primary side can be used for Flags pull up voltage.



## 7 List of Materials (PD70224 + PD70210)

Item	Description	Qty	Reference	Mfr Name	Mfr Part Number
1	HDbaseT, AF/AT PD CHIP Front End PD70210	1	U1	Microsemi	PD70210ILD
2	Ideal Diode Bridg dual bridge 6x8 SMT PD70224k	1	U2	Microsemi	PD70224ILQ
3	Capacitor, X7R, 100nF,100v, 10% 0603	2	C1,C96	Murata	GRM188R72A104KA35D
4	Capacitor,X7R, 1uF, 25V, 10% 0603	1	C2	Murata	GRM188R71E105KA12D
5	CAP CRM 100nF 100V 10% <sup>^</sup> X7R 1206 SMT	1	C4	AVX	12061C104KAT2A
6	CAP CRM 10nF 100V 5% X7R 0805 SMT	4	C35,C36,C37,C38	Kemet	C0805C103J1RAC
7	CAP CRM 1nF/2000V 10% <sup>++</sup> X7R 1206 SMT	1	C88	Walsin	1206B102K202CT
8	CAP CRM 1nF 200V 10% X7R 1206 SMT	2	C91,C92	Vishay	VJ1206Y102KXCT
9	CAP CER 0.1uF 10V X7R 10% 0402 SMT	1	C95	Nic	NMC0402X7R104K10TRP
10	DIO TVS 58V 40A SRG 400WPK SMA SMT	1	D3	Diodes Inc.	SMAJ58A
11	LED SuperYelGrn 100-130o 0603 SMD	5	D9,D10,D11,D12,D14	Everlight	19-21-SYGCS530E3TR8
12	DIO 20V 225mW 5% Ir=50nASOT23 SMT	1	D59	ON Semi	BZX84C20LT1G
13	DIO DUAL 70V 200mA 250mW COM. CAT SOT23	1	D60	Infineon	BAV70
14	CON RJ45 SINGLE 8 POS. SHILDED	1	J1	Bel Stewart	SS71800-007F
15	Insulated Banana Socket 4mm Red	1	J4	Deltron	571-0500
16	Terminal block 2 pole interlocking 5mm pitch	1	J5	Degson	DG105R-5.0-02P-14
17	Insulated Banana Socket 4mm Black	1	J6	Deltron	571-0100
18	TRN NPN 250V 1A 15W D-Pak SMT	1	Q3	Fairchild	MJD47TF
19	Resistor, 30.9R 1%, 1/10W 0603	1	R1	Yageo	RC0603FR-0730R9L
20	RES TCK FLM 60.4K 62.5mW 1%0603 SMT	1	R2	Rohm	MCR03EZPFX6042
21	RES TCK FLM 24.9K 62.5mW 1%0603 SMT	1	R3	Samsung	RC1608F2492CS
22	RES 10K 125mW 1%0805 SMT Thick Film	5	R71,R72,R73,R74,R76	KOA	RK73H2ATTD1002F
23	RES TK FLM 20K 250mW 1%1206	1	R75	Rohm	MCR18EZPF2002
24	RES 75R 125mW 1% 0805SMT	4	R139,R140,R141,R142	Bourns	CR0805-FX-75R0-E
25	RES TCK FLM 0R 62.5mW 5% 0603 SMT	1	R144	Samsung	RC1608J000CS
26	RES TCK FLM 7.87K 1% 62.5mW 0402 SMT	2	R151,R152	Yageo	RC0402FR-077K87L
27	RES TCK FLM 0R 62.5mW 5% 0603 SMT	1	R155	Panasonic	ERJ3GEY0R00V
28	RES TCK FLM 24.3K 100mW 1%0805 SMT	2	R167,R170	Yageo	RC0805FRF0724K3L
29	RES 3.65K 125mW 1%0805 SMT MTL FLM	2	R169,R171	Vishay	CRCW08053K65FKET1
30	1000 BASE-T SINGLE PORT MAGNETICS SMT	1	T1	Bel Fuse	S558-10GB-02V



## 8 List of Materials (PD70224 + PD70210A)

Item	Description	Qty	Reference	Mfr Name	Mfr Part Number
1	HDbaseT, AF/AT PD CHIP Front End PD70210A	1	U1	Microsemi	PD70210AILD
2	Ideal Diode Bridg dual bridge 6x8 SMT PD70224k	1	U2	Microsemi	PD70224ILQ
3	Capacitor, X7R, 100nF, 100v, 10% 0603	2	C1,C96	Murata	GRM188R72A104KA35D
4	Capacitor,X7R, 1uF, 25V, 10% 0603	1	C2	Murata	GRM188R71E105KA12D
5	CAP CRM 100nF 100V 10% X7R 1206 SMT	1	C4	AVX	12061C104KAT2A
6	CAP CRM 10nF 100V 5% X7R 0805 SMT	4	C35,C36,C37,C38, C90	Kemet	C0805C103J1RAC
7	CAP CRM 1nF/2000V 10% X7R 1206 SMT	1	C88	Walsin	1206B102K202CT
8	CAP CRM 1nF 200V 10% X7R 1206 SMT	2	C91,C92	Vishay	VJ1206Y102KXCT
9	CAP CER 0.1uF 10V X7R 10% 0402 SMT	2	C95, C97	Nic	NMC0402X7R104K10TRP
10	DIO TVS 58V 40A SRG 400WPK SMA SMT	1	D3	Diodes Inc.	SMAJ58A
11	LED SuperYelGrn 100-130o 0603 SMD	5	D9,D10,D11,D12,D14	Everlight	19-21-SYGCS530E3TR8
12	DIO SCHOTTKY 90V 1A SMAREC SMT	1	D13	Vishay	SS1H10-E3
13	DIO 20V 225mW 5% Ir=50nASOT23 SMT	1	D59	ON Semi	BZX84C20LT1G
14	DIO DUAL 70V 200mA 250mW COM. CAT SOT23	1	D60	Infineon	BAV70
15	CON RJ45 SINGLE 8 POS. SHILDED	1	J1	Bel Stewart	SS71800-007F
16	Insulated Banana Socket 4mm Red	1	J4	Deltron	571-0500
17	Terminal block 2 pole interlocking 5mm pitch	1	J5	Degson	DG105R-5.0-02P-14
18	Insulated Banana Socket 4mm Black	1	J6	Deltron	571-0100
19	TRN NPN 250V 1A 15W D-Pak SMT	1	Q3	Fairchild	MJD47TF
20	Resistor, 30.9R 1%, 1/10W 0603	1	R1	Yageo	RC0603FR-0730R9L
21	RES TCK FLM 60.4K 62.5mW 1%0603 SMT	1	R2	Rohm	MCR03EZPFX6042
22	RES TCK FLM 24.9K 62.5mW 1%0603 SMT	1	R3	Samsung	RC1608F2492CS
23	RES 10K 125mW 1%0805 SMT Thick Film	5	R71,R72,R73,R74,R76	KOA	RK73H2ATTD1002F
24	RES TK FLM 20K 250mW 1%1206	1	R75	Rohm	MCR18EZPF2002
25	RES 75R 125mW 1% 0805SMT	4	R139,R140,R141,R142	Bourns	CR0805-FX-75R0-E
26	RES TCK FLM 2K 62.5mW 5%0603 SMT	1	R149	Samsung	RC1608J202CS
27	RES TCK FLM 15K 0.25W 1% 1206 SMT	2	R150, R153	Rohm	LTR18EZPF1502
28	RES TCK FLM 7.87K 1% 62.5mW 0402 SMT	2	R151,R152	Yageo	RC0402FR-077K87L
29	Resistor, 820 Ohm, 1%, 1/16W 0603	1	R154	Vishay	CRCW0603820RFKEA
30	RES 620 OHM 1/10W 1% 0603 SMT	1	R155	Yageo	RC0603JR-07620RL
31	RES TCK FLM 24.3K 100mW 1%0805 SMT	2	R167,R170	Yageo	RC0805FRF0724K3L
32	RES 3.65K 125mW 1%0805 SMT MTL FLM	2	R169,R171	Vishay	CRCW08053K65FKET1
33	1000 BASE-T SINGLE PORT MAGNETICS SMT	1	T1	Bel Fuse	S558-10GB-02V
34	MOSFET P-CH 200V 35MA SOT23-3	1	Q1	Diodes Inc.	ZVP1320FTA
35	CON DC POWER JACK RA2.0X6.3 T/H	1	J2	Switchcraft	RAPC722X-TB13



## 9 Board Layout

This paragraph presents the layout of the evaluation board.

The board is a 2-layers board. The layers are 2 Oz layers. Below figures present the two copper layers and the silk of the board for tracking devices placements.

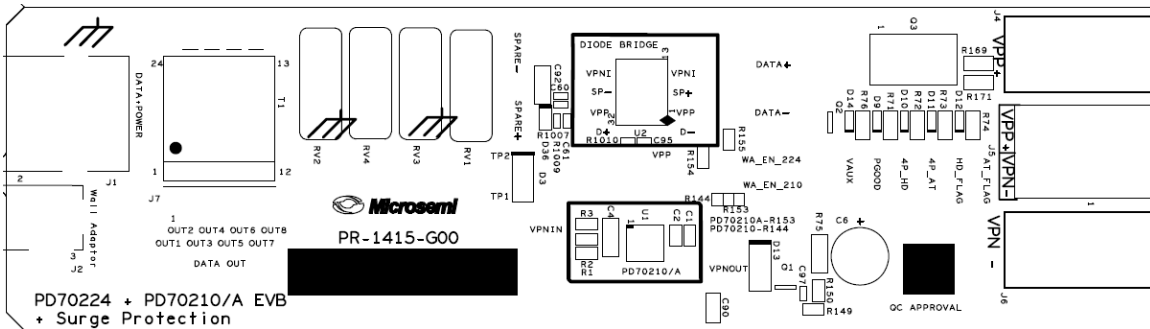

Figure 3: PD70224EVB PCB Silk Top

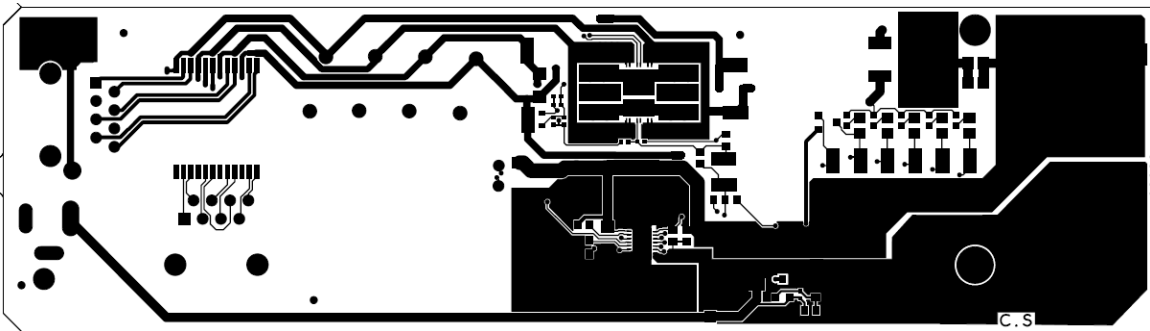

Figure 4: PD70224EVB PCB Top Copper

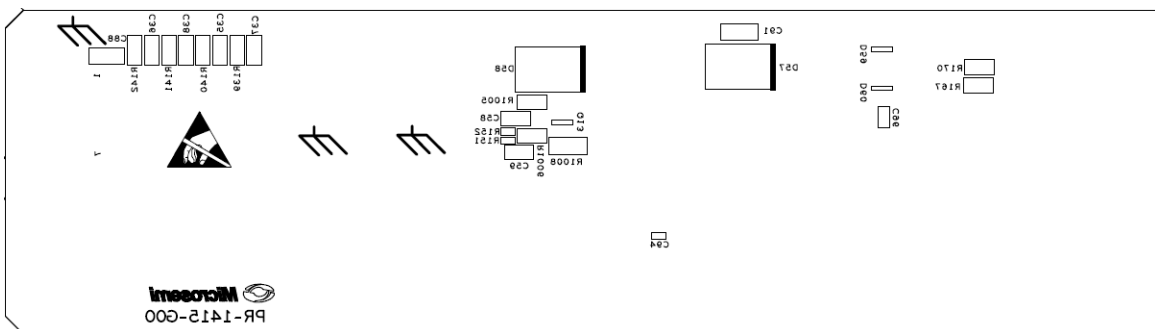

Figure 5: PD70224EVB PCB Silk Bottom

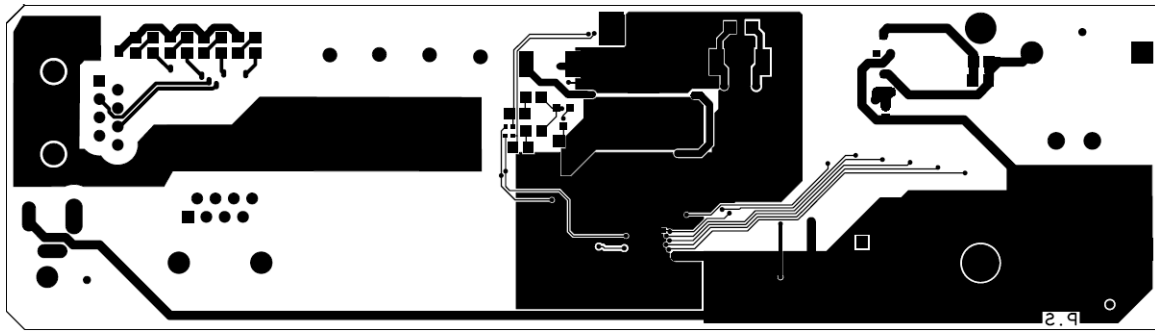

Figure 6: PD70224EVB PCB Bottom Copper



The information contained in the document is PROPRIETARY AND CONFIDENTIAL information of Microsemi and cannot be copied, published, uploaded, posted, transmitted, distributed or disclosed or used without the express duly signed written consent of Microsemi. If the recipient of this document has entered into a disclosure agreement with Microsemi, then the terms of such Agreement will also apply. This document and the information contained herein may not be modified, by any person other than authorized personnel of Microsemi. No license under any patent, copyright, trade secret or other intellectual property right is granted to or conferred upon you by disclosure or delivery of the information, either expressly, by implication, inducement, estoppels or otherwise. Any license under such intellectual property rights must be approved by Microsemi in writing signed by an officer of Microsemi.

Microsemi reserves the right to change the configuration, functionality and performance of its products at anytime without any notice. This product has been subject to limited testing and should not be used in conjunction with life-support or other mission-critical equipment or applications. Microsemi assumes no liability whatsoever, and Microsemi disclaims any express or implied warranty, relating to sale and/or use of Microsemi products including liability or warranties relating to fitness for a particular purpose, merchantability, or infringement of any patent, copyright or other intellectual property right. The product is subject to other terms and conditions which can be located on the web at <http://www.microsemi.com/legal/tnc.asp>

### Revision History

Revision Level / Date	Para. Affected/Page	Description
0.1 / 20-Jan-14		Initial revision
1.0 / 04-Nov-14		Update the board schematics, pictures and layers due to a new PCB revision
2.0 / 08-Feb-17		Added information on the version with WA and PD70210A

© 2014 Microsemi Corp.

All rights reserved.

For support contact: [PoEsupport@microsemi.com](mailto:PoEsupport@microsemi.com)

Visit our web site at: [www.microsemi.com](http://www.microsemi.com)

Catalog Number: PD70224\_UG\_EVB

## X-ON Electronics

Largest Supplier of Electrical and Electronic Components

*Click to view similar products for [Other Development Tools](#) category:*

*Click to view products by [Microchip](#) manufacturer:*

Other Similar products are found below :

[BK0004](#) [BK0012](#) [MAX9684EVKIT#](#) [EVAL01-HMC749LC3C](#) [410-320](#) [TPD6F002-Q1EVM](#) [TS9002DB](#) [118777-HMC722LC3C](#) [118777-HMC723LC3C](#) [DC1765A-A](#) [125614-HMC851LC3C](#) [DC2062A-A](#) [LMH6321MR-EVAL/NOPB](#) [EVAL01-HMC747LC3C](#) [4537](#) [DK-M3F-1.8-TRK-1.5-S](#) [DK-M3-FS-1.8-1.5-M12/16](#) [DK-M3-LS-1.8-6](#) [ADALP2000](#) [EVAL-CN0202-SDPZ](#) [EVAL-CN0203-SDPZ](#) [EVAL-CN0204-SDPZ](#) [EVAL-CN0209-SDPZ](#) [EVAL-CN0229-SDPZ](#) [EVAL-CN0251-SDPZ](#) [EVAL-CN0272-SDPZ](#) [EVAL-CN0301-SDPZ](#) [EVAL-CN0355-PMDZ](#) [EVAL-CN0364-SDPZ](#) [EVAL-SDP-CB1Z](#) [MAX4951AEEVKIT+](#) [MAXREFDES60#](#) [BK0010](#) [EFIELDDEV](#) [PD70224EVB](#) [MIKROE-3319](#) [MIKROE-3357](#) [MIKROE-4048](#) [MIKROE-1370](#) [MIKROE-1899](#) [MIKROE-1901](#) [MIKROE-1910](#) [MIKROE-1917](#) [MIKROE-1993](#) [MIKROE-3116](#) [MIKROE-957](#) [BB-GEVK](#) [NCS2200AGEVB](#) [27115](#) [64019](#)