



# **PIC12F519**

## **Data Sheet**

### **8-Pin, 8-Bit Flash Microcontrollers**

\*8-bit, 8-pin devices protected by Microchip's Low Pin Count Patent: U.S. Patent No. 5,847,450. Additional U.S. and foreign patents and applications may be issued or pending.

---

**Note the following details of the code protection feature on Microchip devices:**

- Microchip products meet the specification contained in their particular Microchip Data Sheet.
- Microchip believes that its family of products is one of the most secure families of its kind on the market today, when used in the intended manner and under normal conditions.
- There are dishonest and possibly illegal methods used to breach the code protection feature. All of these methods, to our knowledge, require using the Microchip products in a manner outside the operating specifications contained in Microchip's Data Sheets. Most likely, the person doing so is engaged in theft of intellectual property.
- Microchip is willing to work with the customer who is concerned about the integrity of their code.
- Neither Microchip nor any other semiconductor manufacturer can guarantee the security of their code. Code protection does not mean that we are guaranteeing the product as "unbreakable."

Code protection is constantly evolving. We at Microchip are committed to continuously improving the code protection features of our products. Attempts to break Microchip's code protection feature may be a violation of the Digital Millennium Copyright Act. If such acts allow unauthorized access to your software or other copyrighted work, you may have a right to sue for relief under that Act.

---

Information contained in this publication regarding device applications and the like is provided only for your convenience and may be superseded by updates. It is your responsibility to ensure that your application meets with your specifications. MICROCHIP MAKES NO REPRESENTATIONS OR WARRANTIES OF ANY KIND WHETHER EXPRESS OR IMPLIED, WRITTEN OR ORAL, STATUTORY OR OTHERWISE, RELATED TO THE INFORMATION, INCLUDING BUT NOT LIMITED TO ITS CONDITION, QUALITY, PERFORMANCE, MERCHANTABILITY OR FITNESS FOR PURPOSE. Microchip disclaims all liability arising from this information and its use. Use of Microchip devices in life support and/or safety applications is entirely at the buyer's risk, and the buyer agrees to defend, indemnify and hold harmless Microchip from any and all damages, claims, suits, or expenses resulting from such use. No licenses are conveyed, implicitly or otherwise, under any Microchip intellectual property rights.

**Trademarks**

The Microchip name and logo, the Microchip logo, Accuron, dsPIC, KEELOQ, KEELOQ logo, MPLAB, PIC, PICmicro, PICSTART, rPIC, SmartShunt and UNI/O are registered trademarks of Microchip Technology Incorporated in the U.S.A. and other countries.

FilterLab, Linear Active Thermistor, MXDEV, MXLAB, SEEVAL, SmartSensor and The Embedded Control Solutions Company are registered trademarks of Microchip Technology Incorporated in the U.S.A.

Analog-for-the-Digital Age, Application Maestro, CodeGuard, dsPICDEM, dsPICDEM.net, dsPICworks, dsSPEAK, ECAN, ECONOMONITOR, FanSense, In-Circuit Serial Programming, ICSP, ICEPIC, Mindi, MiWi, MPASM, MPLAB Certified logo, MPLIB, MPLINK, mTouch, PICkit, PICDEM, PICDEM.net, PICTail, PIC<sup>32</sup> logo, PowerCal, PowerInfo, PowerMate, PowerTool, REAL ICE, rLAB, Select Mode, Total Endurance, WiperLock and ZENA are trademarks of Microchip Technology Incorporated in the U.S.A. and other countries.

SQTP is a service mark of Microchip Technology Incorporated in the U.S.A.

All other trademarks mentioned herein are property of their respective companies.

© 2008, Microchip Technology Incorporated, Printed in the U.S.A., All Rights Reserved.

 Printed on recycled paper.

**QUALITY MANAGEMENT SYSTEM**  
**CERTIFIED BY DNV**  
**== ISO/TS 16949:2002 ==**

*Microchip received ISO/TS-16949:2002 certification for its worldwide headquarters, design and wafer fabrication facilities in Chandler and Tempe, Arizona; Gresham, Oregon and design centers in California and India. The Company's quality system processes and procedures are for its PIC<sup>®</sup> MCUs and dsPIC<sup>®</sup> DSCs, KEELOQ<sup>®</sup> code hopping devices, Serial EEPROMs, microperipherals, nonvolatile memory and analog products. In addition, Microchip's quality system for the design and manufacture of development systems is ISO 9001:2000 certified.*

---

---

## 8-Pin, 8-Bit Flash Microcontroller

---

---

### High-Performance RISC CPU:

- Only 33 Single-Word Instructions
- All Single-Cycle Instructions except for Program Branches which are Two-Cycle
- Two-Level Deep Hardware Stack
- Direct, Indirect and Relative Addressing modes for Data and Instructions
- Operating Speed:
  - DC – 8 MHz Oscillator
  - DC – 500 ns instruction cycle
- On-chip Flash Program Memory
  - 1024 x 12
- General Purpose Registers (SRAM)
  - 41 x 8
- Flash Data Memory
  - 64 x 8

### Special Microcontroller Features:

- 8 MHz Precision Internal Oscillator
  - Factory calibrated to  $\pm 1\%$
- In-Circuit Serial Programming™ (ICSP™)
- In-Circuit Debugging (ICD) Support
- Power-on Reset (POR)
- Device Reset Timer (DRT)
- Watchdog Timer (WDT) with Dedicated On-Chip RC Oscillator for Reliable Operation
- Programmable Code Protection
- Multiplexed MCLR Input Pin
- Internal Weak Pull-ups on I/O Pins
- Power-Saving Sleep mode
- Wake-up from Sleep on Pin Change
- Selectable Oscillator Options:
  - INTRC: 4 MHz or 8 MHz precision Internal RC oscillator
  - EXTRC: External low-cost RC oscillator
  - XT: Standard crystal/resonator
  - LP: Power-saving, low-frequency crystal

### Low-Power Features/CMOS Technology:

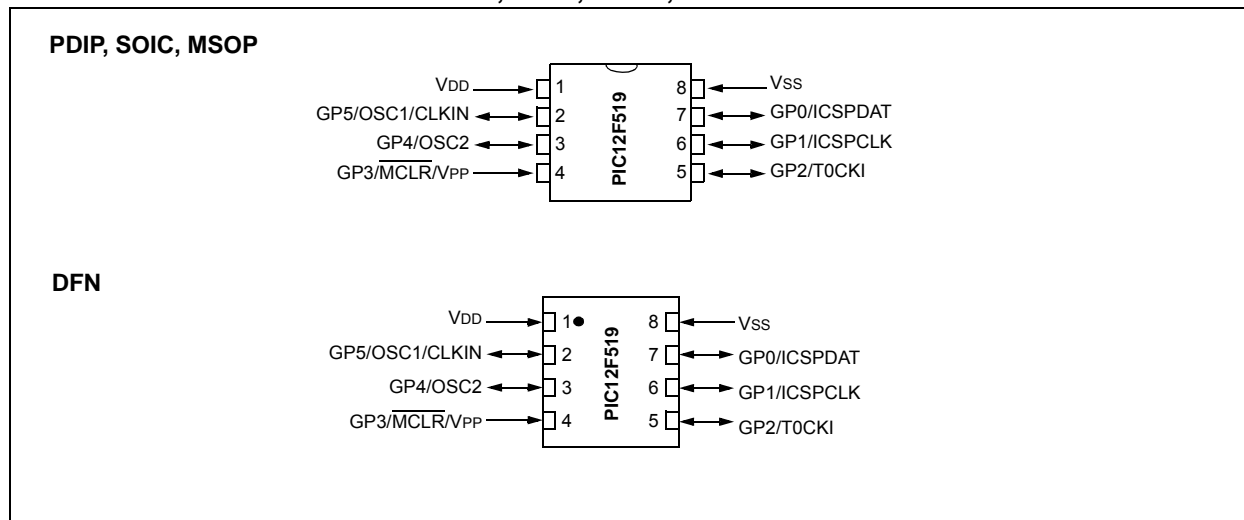
- Standby Current:
  - 100 nA @ 2.0V, typical
- Operating Current:
  - 11  $\mu\text{A}$  @ 32 kHz, 2.0V, typical
  - 175  $\mu\text{A}$  @ 4 MHz, 2.0V, typical
- Watchdog Timer Current:
  - 1  $\mu\text{A}$  @ 2.0V, typical
  - 7  $\mu\text{A}$  @ 5.0V, typical
- High Endurance Program and Flash Data Memory Cells
  - 100,000 write Program Memory endurance
  - 1,000,000 write Flash Data Memory endurance
  - Program and Flash Data retention: >40 years
- Fully Static Design
- Wide Operating Voltage Range: 2.0V to 5.5V
  - Wide temperature range
  - Industrial: -40°C to +85°C
  - Extended: -40°C to +125°C

### Peripheral Features:

- 6 I/O Pins
  - 5 I/O pins with individual direction control
  - 1 input-only pin
  - High current sink/source for direct LED drive
- 8-bit Real-Time Clock/Counter (TMR0) with 8-bit Programmable Prescaler.

# PIC12F519

**FIGURE 1: PIC12F519 8-PIN PDIP, SOIC, MSOP, 2X3 DFN DIAGRAM**



Device	Program Memory	Data Memory		I/O	Timers 8-bit
	Flash (words)	SRAM (bytes)	Flash (bytes)		
PIC12F519	1024	41	64	6	1

## Table of Contents

1.0	General Description .....	5
2.0	PIC12F519 Device Varieties .....	7
3.0	Architectural Overview .....	9
4.0	Memory Organization .....	13
5.0	Flash Data Memory .....	21
6.0	I/O Port .....	23
7.0	Timer0 Module and TMR0 Register .....	31
8.0	Special Features Of The CPU .....	37
9.0	Instruction Set Summary .....	49
10.0	Development Support .....	57
11.0	Electrical Characteristics .....	61
12.0	DC and AC Characteristics Graphs and Charts .....	73
13.0	Packaging Information .....	83
	Index .....	89
	The Microchip Web Site .....	91
	Customer Change Notification Service .....	91
	Customer Support .....	91
	Reader Response .....	92
	Product Identification System .....	93

## TO OUR VALUED CUSTOMERS

It is our intention to provide our valued customers with the best documentation possible to ensure successful use of your Microchip products. To this end, we will continue to improve our publications to better suit your needs. Our publications will be refined and enhanced as new volumes and updates are introduced.

If you have any questions or comments regarding this publication, please contact the Marketing Communications Department via E-mail at [docerrors@mail.microchip.com](mailto:docerrors@mail.microchip.com) or fax the **Reader Response Form** in the back of this data sheet to (480) 792-4150. We welcome your feedback.

### Most Current Data Sheet

To obtain the most up-to-date version of this data sheet, please register at our Worldwide Web site at:

<http://www.microchip.com>

You can determine the version of a data sheet by examining its literature number found on the bottom outside corner of any page. The last character of the literature number is the version number, (e.g., DS30000A is version A of document DS30000).

### Errata

An errata sheet, describing minor operational differences from the data sheet and recommended workarounds, may exist for current devices. As device/documentation issues become known to us, we will publish an errata sheet. The errata will specify the revision of silicon and revision of document to which it applies.

To determine if an errata sheet exists for a particular device, please check with one of the following:

- Microchip's Worldwide Web site; <http://www.microchip.com>
- Your local Microchip sales office (see last page)
- The Microchip Corporate Literature Center; U.S. FAX: (480) 792-7277

When contacting a sales office or the literature center, please specify which device, revision of silicon and data sheet (include literature number) you are using.

### Customer Notification System

Register on our web site at [www.microchip.com/cn](http://www.microchip.com/cn) to receive the most current information on all of our products.

# PIC12F519

---

NOTES:

## 1.0 GENERAL DESCRIPTION

The PIC12F519 device from Microchip Technology is low-cost, high-performance, 8-bit, fully-static, Flash-based CMOS microcontrollers. They employ a RISC architecture with only 33 single-word/single-cycle instructions. All instructions are single cycle except for program branches, which take two cycles. The PIC12F519 device delivers performance an order of magnitude higher than their competitors in the same price category. The 12-bit wide instructions are highly symmetrical, resulting in a typical 2:1 code compression over other 8-bit microcontrollers in its class. The easy-to-use and easy to remember instruction set reduces development time significantly.

The PIC12F519 product is equipped with special features that reduce system cost and power requirements. The Power-on Reset (POR) and Device Reset Timer (DRT) eliminate the need for external Reset circuitry. There are four oscillator configurations to choose from including INTRC Internal Oscillator mode and the power-saving LP (Low-power) Oscillator mode. Power-Saving Sleep mode, Watchdog Timer and code protection features improve system cost, power and reliability.

The PIC12F519 device is available in the cost-effective Flash programmable version, which is suitable for production in any volume. The customer can take full advantage of Microchip's price leadership in Flash programmable microcontrollers, while benefiting from the Flash programmable flexibility.

The PIC12F519 product is supported by a full-featured macro assembler, a software simulator, an in-circuit emulator, a low-cost development programmer and a full featured programmer. All the tools are supported on PC and compatible machines.

## 1.1 Applications

The PIC12F519 device fits in applications ranging from personal care appliances and security systems to low-power remote transmitters/receivers. The Flash technology makes customizing application programs (transmitter codes, appliance settings, receiver frequencies, etc.) extremely fast and convenient. The small footprint packages, for through hole or surface mounting, make these microcontrollers perfect for applications with space limitations. Low cost, low power, high performance, ease of use and I/O flexibility make the PIC12F519 device very versatile even in areas where no microcontroller use has been considered before (e.g., timer functions, logic and PLDs in larger systems and coprocessor applications).

**TABLE 1-1: FEATURES AND MEMORY OF PIC12F519**

		PIC12F519
Clock	Maximum Frequency of Operation (MHz)	8
Memory	Flash Program Memory	1024
	SRAM Data Memory (bytes)	41
	Flash Data Memory (bytes)	64
Peripherals	Timer Module(s)	TMR0
	Wake-up from Sleep on Pin Change	Yes
Features	I/O Pins	5
	Input Pins	1
	Internal Pull-ups	Yes
	In-Circuit Serial Programming™	Yes
	Number of Instructions	33
	Packages	8-pin PDIP, SOIC, MSOP, 2X3 DFN

The PIC12F519 device has Power-on Reset, selectable Watchdog Timer, selectable code-protect, high I/O current capability and precision internal oscillator.

The PIC12F519 device uses serial programming with data pin GP0 and clock pin GP1.

# PIC12F519

---

NOTES:



## 2.0 PIC12F519 DEVICE VARIETIES

When placing orders, please use the PIC12F519 Product Identification System at the back of this data sheet to specify the correct part number. A variety of packaging options are available. Depending on application and production requirements, the proper device option can be selected using the information in this section.

### 2.1 Quick Turn Programming (QTP) Devices

Microchip offers a QTP programming service for factory production orders. This service is made available for users who choose not to program medium-to-high quantity units and whose code patterns have stabilized. The devices are identical to the Flash devices but with all Flash locations and fuse options already programmed by the factory. Certain code and prototype verification procedures do apply before production shipments are available. Please contact your local Microchip Technology sales office for more details.

### 2.2 Serialized Quick Turn Programming<sup>SM</sup> (SQTP<sup>SM</sup>) Devices

Microchip offers a unique programming service, where a few user-defined locations in each device are programmed with different serial numbers. The serial numbers may be random, pseudo-random or sequential.

Serial programming allows each device to have a unique number, which can serve as an entry code, password or ID number.

# PIC12F519

---

NOTES:

## 3.0 ARCHITECTURAL OVERVIEW

The high performance of the PIC12F519 device can be attributed to a number of architectural features commonly found in RISC microprocessors. To begin with, the PIC12F519 device uses a Harvard architecture in which program and data are accessed on separate buses. This improves bandwidth over traditional von Neumann architectures where program and data are fetched on the same bus. Separating program and data memory further allows instructions to be sized differently than the 8-bit wide data word. Instruction opcodes are 12 bits wide, making it possible to have all single-word instructions. A 12-bit wide program memory access bus fetches a 12-bit instruction in a single cycle. A two-stage pipeline overlaps fetch and execution of instructions. Consequently, all instructions (33) execute in a single cycle (500 ns @ 8 MHz, 1  $\mu$ s @ 4 MHz) except for program branches.

Table 3-1 below lists memory supported by the PIC12F519 device.

**TABLE 3-1: PIC12F519 MEMORY**

Device	Program Memory	Data Memory	
	Flash (words)	SRAM (bytes)	Flash Data (bytes)
PIC12F519	1024	41	64

The PIC12F519 device can directly or indirectly address its register files and data memory. All Special Function Registers (SFR), including the PC, are mapped in the data memory. The PIC12F519 device has a highly orthogonal (symmetrical) instruction set that makes it possible to carry out any operation, on any register, using any addressing mode. This symmetrical nature and lack of “special optimal situations” make programming with the PIC12F519 device simple, yet efficient. In addition, the learning curve is reduced significantly.

The PIC12F519 device contains an 8-bit ALU and working register. The ALU is a general purpose arithmetic unit. It performs arithmetic and Boolean functions between data in the working register and any register file.

The ALU is 8 bits wide and capable of addition, subtraction, shift and logical operations. Unless otherwise mentioned, arithmetic operations are two's complement in nature. In two-operand instructions, one operand is typically the W (working) register. The other operand is either a file register or an immediate constant. In single operand instructions, the operand is either the W register or a file register.

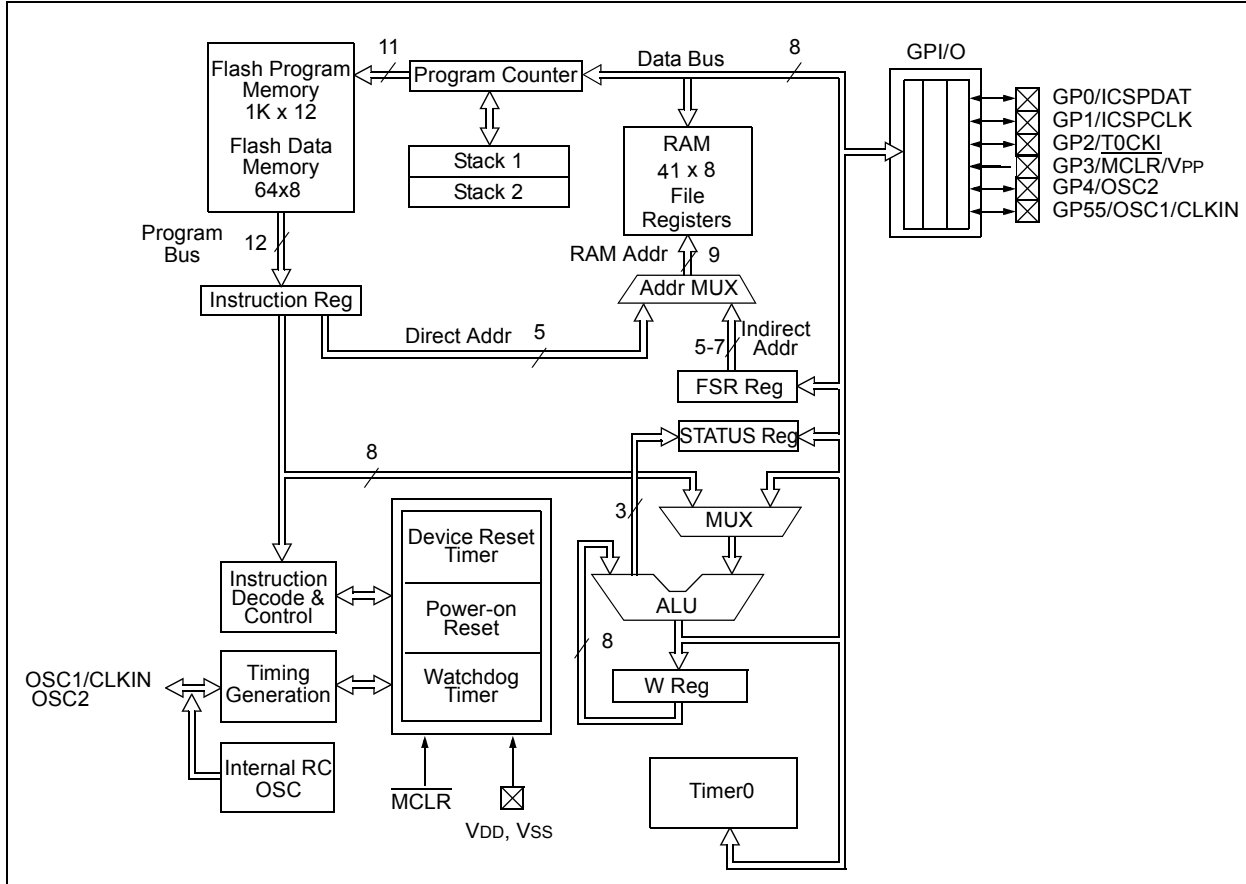
The W register is an 8-bit working register used for ALU operations. It is not an addressable register.

Depending on the instruction executed, the ALU may affect the values of the Carry (C), Digit Carry (DC) and Zero (Z) bits in the STATUS register. The C and DC bits operate as a borrow and digit borrow out bit, respectively, in subtraction. See the SUBWF and ADDWF instructions for examples.

A simplified block diagram is shown in Figure 3-1, with the corresponding device pins described in Table 3-2.

# PIC12F519

FIGURE 3-1: PIC12F519 ARCHITECTURAL BLOCK DIAGRAM



**TABLE 3-2: PIC12F519 PINOUT DESCRIPTION**

Name	Function	Type	Input Type	Output Type	Description
GP0/ICSPDAT	GP0	I/O	TTL	CMOS	Bidirectional I/O port with weak pull-up
	ICSPDAT	I/O	ST	CMOS	ICSP™ mode Schmitt Trigger
GP1/ICSPCLK	GP1	I/O	TTL	CMOS	Bidirectional I/O port with weak pull-up
	ICSPCLK	I	ST	—	ICSP™ mode Schmitt Trigger
GP2/T0CKI	GP2	I/O	TTL	CMOS	Bidirectional I/O port
	T0CKI	I	ST	—	Timer0 clock input
GP3/MCLR/VPP	GP3	I	TTL	—	Standard TTL input with weak pull-up
	MCLR	I	ST	—	MCLR input (Weak pull-up always enabled in this mode)
	VPP	I	High Voltage	—	Test mode high voltage pin
GP4/OSC2	GP4	I/O	TTL	CMOS	Bidirectional I/O port
	OSC2	O	—	XTAL	XTAL oscillator output pin
GP5/OSC1/CLKIN	GP5	I/O	TTL	CMOS	Bidirectional I/O port
	OSC1	I	XTAL	—	XTAL oscillator input pin
	CLKIN	I	ST	—	EXTRC Schmitt Trigger input
VDD	VDD	P	—	—	Positive supply for logic and I/O pins
VSS	VSS	P	—	—	Ground reference for logic and I/O pins

**Legend:** I = Input, O = Output, I/O = Input/Output, P = Power, — = Not Used, TTL = TTL input, ST = Schmitt Trigger input, AN = Analog Voltage

# PIC12F519

## 3.1 Clocking Scheme/Instruction Cycle

The clock input (OSC1/CLKIN pin) is internally divided by four to generate four non-overlapping quadrature clocks, namely Q1, Q2, Q3 and Q4. Internally, the PC is incremented every Q1 and the instruction is fetched from program memory and latched into the instruction register in Q4. It is decoded and executed during the following Q1 through Q4. The clocks and instruction execution flow is shown in Figure 3-2 and Example 3-1.

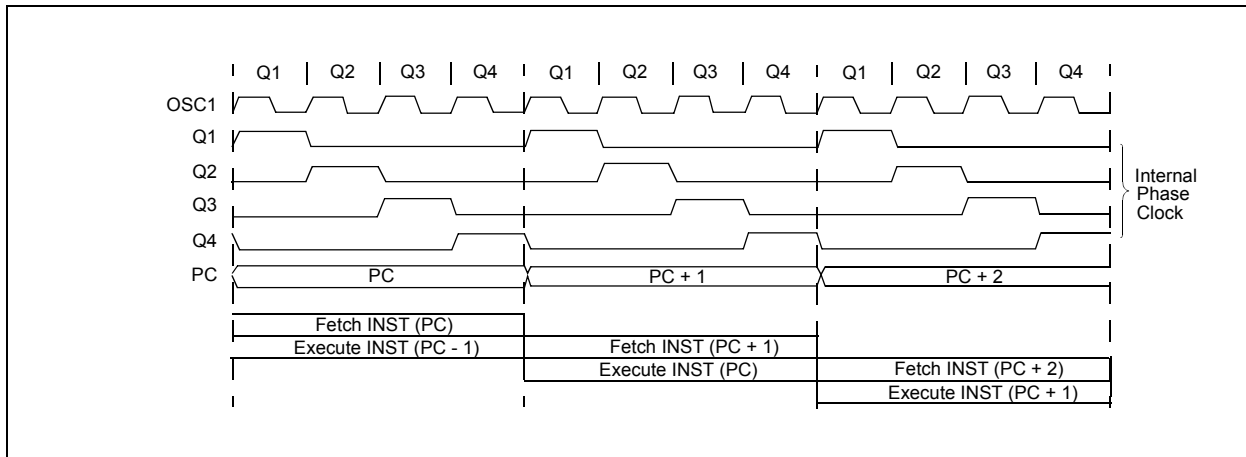
## 3.2 Instruction Flow/Pipelining

An instruction cycle consists of four Q cycles (Q1, Q2, Q3 and Q4). The instruction fetch and execute are pipelined such that fetch takes one instruction cycle, while decode and execute take another instruction cycle. However, due to the pipelining, each instruction effectively executes in one cycle. If an instruction causes the PC to change (e.g., GOTO), then two cycles are required to complete the instruction (Example 3-1).

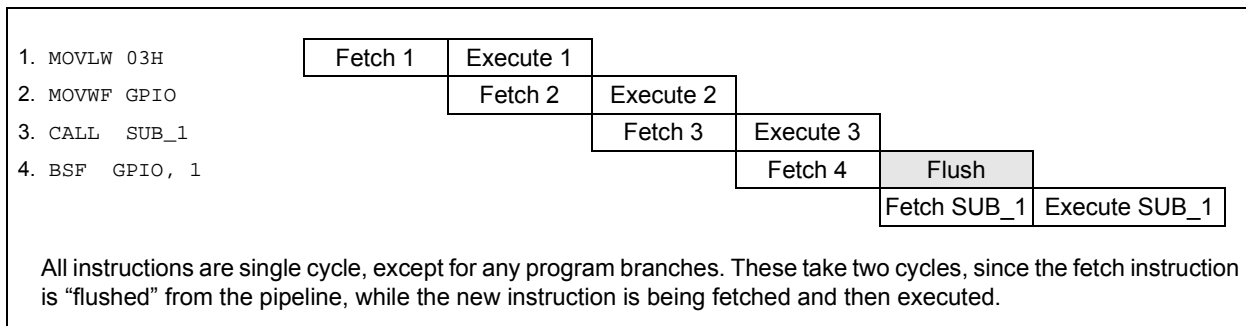
A fetch cycle begins with the PC incrementing in Q1.

In the execution cycle, the fetched instruction is latched into the Instruction Register (IR) in cycle Q1. This instruction is then decoded and executed during the Q2, Q3 and Q4 cycles. Data memory is read during Q2 (operand read) and written during Q4 (destination write).

**FIGURE 3-2: CLOCK/INSTRUCTION CYCLE**



**EXAMPLE 3-1: INSTRUCTION PIPELINE FLOW**



## 4.0 MEMORY ORGANIZATION

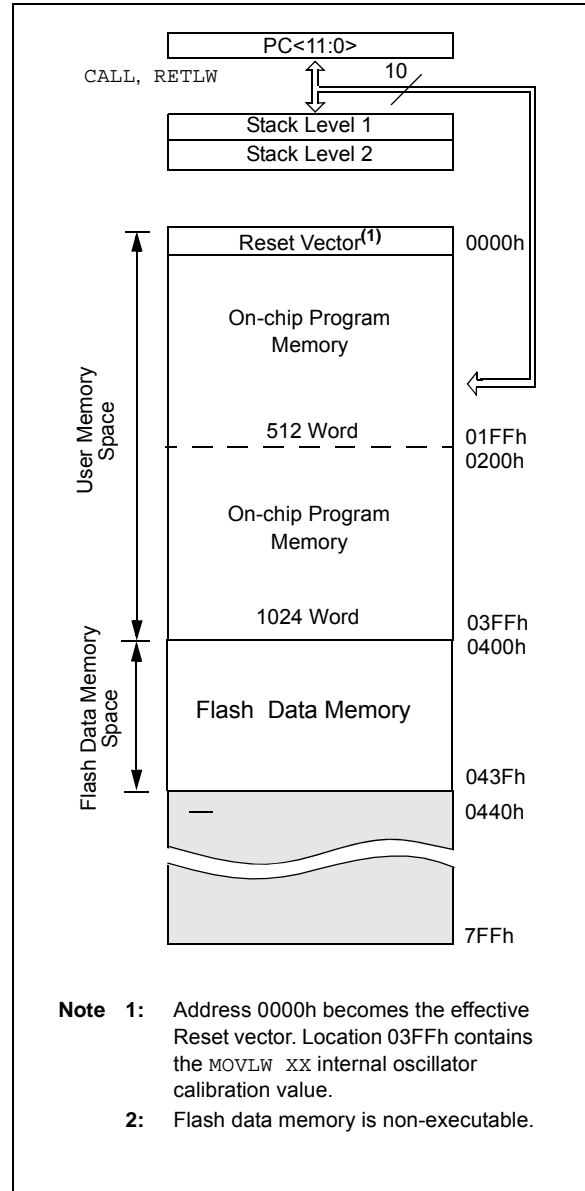
The PIC12F519 memory is organized into program memory and data memory (SRAM). The self-writable portion of the program memory called Flash data memory, is located at addresses 400h-43Fh. As the device has more than 512 bytes of program memory, a paging scheme is used. Program memory pages are accessed using STATUS register bit, PA0. For the PIC12F519, with data memory register files of more than 32 registers, a banking scheme is used. Data memory banks are accessed using the File Select Register (FSR).

### 4.1 Program Memory Organization for the PIC12F519

The PIC12F519 device has an 11-bit Program Counter (PC) capable of addressing a 2K x 12 program memory space.

Only the first 1K x 12 (0000h-03FFh) are physically implemented (see Figure 4-1). Accessing a location above these boundaries will cause a wrap-around within the 1K x 12 space. The effective Reset vector is a 0000h (see Figure 4-1). Location 03FFh contains the internal clock oscillator calibration value. This value should never be overwritten.

FIGURE 4-1: MEMORY MAP



# PIC12F519

## 4.2 Data Memory (SRAM and FSRs)

Data memory is composed of registers or bytes of SRAM. Therefore, data memory for a device is specified by its register file. The register file is divided into two functional groups: Special Function Registers (SFR) and General Purpose Registers (GPR).

The Special Function Registers include the TMR0 register, the Program Counter Low (PCL), the STATUS register, the I/O register (port) and the File Select Register (FSR). In addition, the EECON, EEDATA and EEADR registers provide for interface with the Flash data memory.

The PIC12F519 register file is composed of 10 Special Function Registers and 41 General Purpose Registers.

### 4.2.1 GENERAL PURPOSE REGISTER FILE

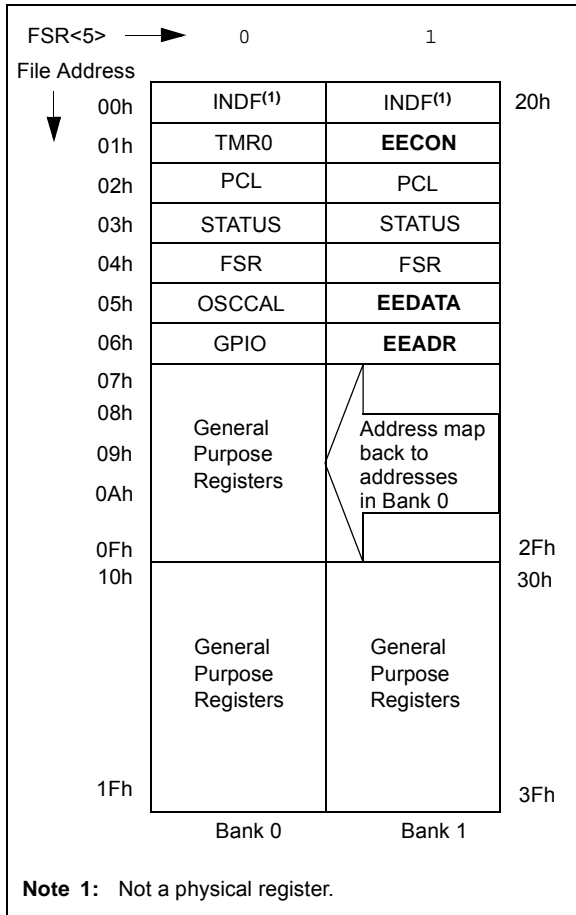
The General Purpose Register file is accessed, either directly or indirectly, through the File Select Register (FSR). See **Section 4.8 “Indirect Data Addressing: INDF and FSR Registers”**.

### 4.2.2 SPECIAL FUNCTION REGISTERS

The Special Function Registers (SFRs) are registers used by the CPU and peripheral functions to control the operation of the device (Table 4-1).

The Special Function Registers can be classified into two sets. The Special Function Registers associated with the “core” functions are described in this section. Those related to the operation of the peripheral features are described in the section for each peripheral feature.

**FIGURE 4-2: REGISTER FILE MAP**





**TABLE 4-1: SPECIAL FUNCTION REGISTER SUMMARY**

Addr	Name	Bit 7	Bit 6	Bit 5	Bit 4	Bit 3	Bit 2	Bit 1	Bit 0	Value on Power-on Reset
N/A	TRISGPIO	—	—	TRISGPIO5	TRISGPIO4	TRISGPIO3	TRISGPIO2	TRISGPIO1	TRISGPIO0	--11 1111
N/A	OPTION	Contains Control Bits to Configure Timer0 and Timer0/WDT Prescaler								1111 1111
00h	INDF	Uses Contents of FSR to Address Data Memory (not a physical register)								xxxx xxxx
01h	TMR0	Timer0 Module Register								xxxx xxxx
02h <sup>(1)</sup>	PCL	Low Order 8 bits of PC								1111 1111
03h	STATUS	GPWUF	—	PA0	$\overline{TO}$	$\overline{PD}$	Z	DC	C	0-01 1xxxx
04h	FSR	Indirect Data Memory Address Pointer								110x xxxx
05h	OSCCAL	CAL6	CAL5	CAL4	CAL3	CAL2	CAL1	CAL0	—	1111 111-
06h	GPIO	—	—	GP5	GP4	GP3	GP2	GP1	GP0	--xx xxxx
21h	EECON	—	—	—	FREE	WRERR	WREN	WR	RD	---0 x000
25h	EEDATA	EEDATA7	EEDATA6	EEDATA5	EEDATA4	EEDATA3	EEDATA2	EEDATA1	EEDATA0	xxxx xxxx
26h	EEADR	—	—	EEADR5	EEADR4	EEADR3	EEADR2	EEADR1	EEADR0	--xx xxxx

**Legend:** x = unknown, u = unchanged, — = unimplemented, read as '0' (if applicable). Shaded cells = unimplemented or unused

**Note 1:** The upper byte of the Program Counter is not directly accessible. See Section 4.6 "Program Counter" for an explanation of how to access these bits.

# PIC12F519

## 4.3 STATUS register

This register contains the arithmetic status of the ALU, the Reset status and the page preselect bit.

The STATUS register can be the destination for any instruction, as with any other register. If the STATUS register is the destination for an instruction that affects the Z, DC or C bits, then the write to these three bits is disabled. These bits are set or cleared according to the device logic. Furthermore, the  $\overline{TO}$  and  $\overline{PD}$  bits are not writable. Therefore, the result of an instruction with the STATUS register as destination may be different than intended.

For example, `CLRF STATUS`, will clear the upper three bits and set the Z bit. This leaves the STATUS register as '000u u1uu' (where u = unchanged).

Therefore, it is recommended that only `BCF`, `BSF` and `MOVWF` instructions be used to alter the STATUS register. These instructions do not affect the Z, DC or C bits from the STATUS register. For other instructions which do affect Status bits, see **Section 9.0 "Instruction Set Summary"**.

**REGISTER 4-1: STATUS: STATUS REGISTER**

R/W-0	U-0	R/W-0	R-1	R-1	R/W-x	R/W-x	R/W-x
GPWUF	—	PA0	$\overline{TO}$	$\overline{PD}$	Z	DC	C
bit 7							bit 0

**Legend:**

R = Readable bit	W = Writable bit	U = Unimplemented bit, read as '0'
-n = Value at POR	'1' = Bit is set	'0' = Bit is cleared
		x = Bit is unknown

- bit 7      **GPWUF:** Wake-up From Sleep on Pin Change bit  
1 = Reset due to wake-up from Sleep on pin change  
0 = After power-up or other Reset
- bit 6      **Unimplemented:** Read as '0'
- bit 5      **PA0:** Program Page Preselect bit  
1 = Page 1 (000h-1FFh)  
0 = Page 0 (200h-3FFh)
- bit 4       **$\overline{TO}$ :** Time-out bit  
1 = After power-up, `CLRWDT` instruction, or `SLEEP` instruction  
0 = A WDT time-out occurred
- bit 3       **$\overline{PD}$ :** Power-down bit  
1 = After power-up or by the `CLRWDT` instruction  
0 = By execution of the `SLEEP` instruction
- bit 2      **Z:** Zero bit  
1 = The result of an arithmetic or logic operation is zero  
0 = The result of an arithmetic or logic operation is not zero
- bit 1      **DC:** Digit carry/borrow bit (for `ADDWF` and `SUBWF` instructions)  
ADDWF :  
1 = A carry from the 4th low-order bit of the result occurred  
0 = A carry from the 4th low-order bit of the result did not occur  
SUBWF :  
1 = A borrow from the 4th low-order bit of the result did not occur  
0 = A borrow from the 4th low-order bit of the result occurred
- bit 0      **C:** Carry/borrow bit (for `ADDWF`, `SUBWF` and `RRF`, `RLF` instructions)  
ADDWF :                      SUBWF :                      RRF or RLF :  
1 = A carry occurred      1 = A borrow did not occur      Load bit with LSB or MSb, respectively  
0 = A carry did not occur      0 = A borrow occurred

## 4.4 OPTION Register

The OPTION register is a 8-bit wide, write-only register, which contains various control bits to configure the Timer0/WDT prescaler and Timer0.

By executing the OPTION instruction, the contents of the W register will be transferred to the OPTION register. A Reset sets the OPTION<7:0> bits.

**Note:** If the T0SC bit is set to '1', it will override the TRIS function on the T0CKI pin.

### REGISTER 4-2: OPTION: OPTION REGISTER

W-1	W-1	W-1	W-1	W-1	W-1	W-1	W-1
$\overline{\text{GPWU}}$	$\overline{\text{GPPU}}$	T0CS	T0SE	PSA	PS2	PS1	PS0
bit 7							bit 0

**Legend:**

R = Readable bit	W = Writable bit	x = Bit is unknown
-n = Value at POR	'1' = Bit is set	'0' = Bit is cleared

- bit 7      **GPWU:** Enable Wake-up On Pin Change bit  
1 = Disabled  
0 = Enabled
- bit 6      **GPPU:** Enable Weak Pull-ups bit  
1 = Disabled  
0 = Enabled
- bit 5      **T0CS:** Timer0 Clock Source Select bit  
1 = Transition on T0CKI pin  
0 = Internal instruction cycle clock (CLKOUT)
- bit 4      **T0SE:** Timer0 Source Edge Select bit  
1 = Increment on high-to-low transition on T0CKI pin  
0 = Increment on low-to-high transition on T0CKI pin
- bit 3      **PSA:** Prescaler Assignment bit  
1 = Prescaler assigned to the WDT  
0 = Prescaler assigned to Timer0
- bit 2-0    **PS<2:0>:** Prescaler Rate Select bits

Bit Value	Timer0 Rate	WDT Rate
000	1 : 2	1 : 1
001	1 : 4	1 : 2
010	1 : 8	1 : 4
011	1 : 16	1 : 8
100	1 : 32	1 : 16
101	1 : 64	1 : 32
110	1 : 128	1 : 64
111	1 : 256	1 : 128

# PIC12F519

## 4.5 OSCCAL Register

The Oscillator Calibration (OSCCAL) register is used to calibrate the 8 MHz internal oscillator macro. It contains 7 bits of calibration that uses a two's complement scheme for controlling the oscillator speed. See Register 4-3 for details.

**REGISTER 4-3: OSCCAL: OSCILLATOR CALIBRATION REGISTER**

R/W-1	R/W-1	R/W-1	R/W-1	R/W-1	R/W-1	R/W-1	U-0
CAL6	CAL5	CAL4	CAL3	CAL2	CAL1	CAL0	—
bit 7							bit 0

**Legend:**

R = Readable bit	W = Writable bit	U = Unimplemented bit, read as '0'	
-n = Value at POR	'1' = Bit is set	'0' = Bit is cleared	x = Bit is unknown

bit 7-1      **CAL<6:0>**: Oscillator Calibration bits  
0111111 = Maximum frequency  
•  
•  
•  
0000001  
0000000 = Center frequency  
1111111  
•  
•  
•  
1000000 =Minimum frequency  
bit 0      **Unimplemented**: Read as '0'

## 4.6 Program Counter

As a program instruction is executed, the Program Counter (PC) will contain the address of the next program instruction to be executed. The PC value is increased by one every instruction cycle, unless an instruction changes the PC.

For a `GOTO` instruction, bits <8:0> of the PC are provided by the `GOTO` instruction word. The Program Counter (PCL) is mapped to PC<7:0>. Bit 5 of the STATUS register provides page information to bit 9 of the PC (Figure 4-3).

For a `CALL` instruction, or any instruction where the PCL is the destination, bits <7:0> of the PC again are provided by the instruction word. However, PC<8> does not come from the instruction word, but is always cleared (Figure 4-3).

Instructions where the PCL is the destination, or modify PCL instructions, include `MOVWF PCL`, `ADDWF PCL` and `BSF PCL, 5`.

**Note:** Because PC<8> is cleared in the `CALL` instruction or any modify PCL instruction, all subroutine calls or computed jumps are limited to the first 256 locations of any program memory page (512 words long).

### 4.6.1 EFFECTS OF RESET

The PC is set upon a Reset, which means that the PC addresses the last location in the last page (i.e., the oscillator calibration instruction). After executing `MOVLW XX`, the PC will roll over to location 00h and begin executing user code.

The STATUS register page preselect bits are cleared upon a Reset, which means that page 0 is pre-selected.

Therefore, upon a Reset, a `GOTO` instruction will automatically cause the program to jump to page 0 until the value of the page bits is altered.

## 4.7 Stack

The PIC12F519 device has a two-deep, 12-bit wide hardware PUSH/POP stack.

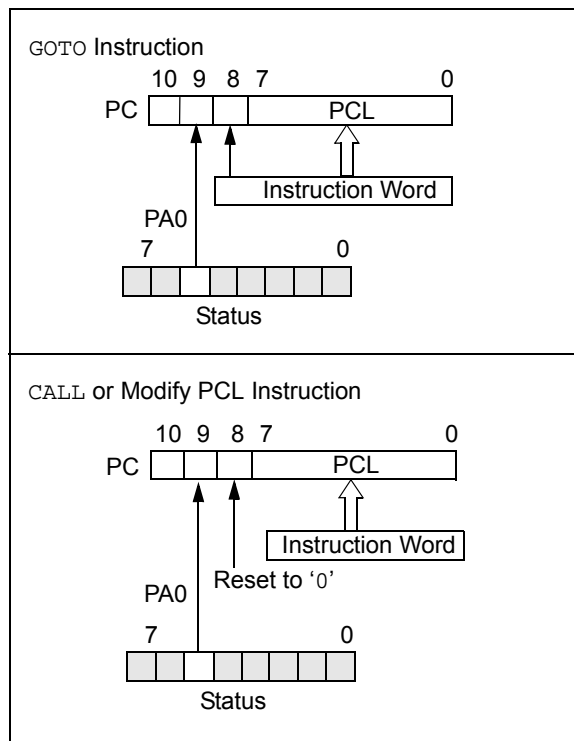
A `CALL` instruction will PUSH the current value of Stack 1 into Stack 2 and then PUSH the current PC value, incremented by one, into Stack Level 1. If more than two sequential `CALLs` are executed, only the most recent two return addresses are stored.

A `RETLW` instruction will POP the contents of Stack Level 1 into the PC and then copy Stack Level 2 contents into Stack Level 1. If more than two sequential `RETLWs` are executed, the stack will be filled with the address previously stored in Stack Level 2. Note that the W register will be loaded with the literal value specified in the instruction. This is particularly useful for the implementation of data look-up tables within the program memory.

**Note 1:** There are no Status bits to indicate stack overflows or stack underflow conditions.

**2:** There are no instruction mnemonics called PUSH or POP. These are actions that occur from the execution of the `CALL` and `RETLW` instructions.

**FIGURE 4-3: LOADING OF PC BRANCH INSTRUCTIONS**



# PIC12F519

## 4.8 Indirect Data Addressing: INDF and FSR Registers

The INDF register is not a physical register. Addressing INDF actually addresses the register whose address is contained in the FSR register (FSR is a *pointer*). This is indirect addressing.

Reading INDF itself indirectly (FSR = 0) will produce 00h. Writing to the INDF register indirectly results in a no-operation (although Status bits may be affected).

The FSR is an 8-bit wide register. It is used in conjunction with the INDF Register to indirectly address the data memory area.

The FSR<4:0> bits are used to select data memory addresses 00h to 1Fh.

FSR<5> is used to select between banks (0 = Bank 0, 1 = Bank 1).

FSR<7:6> are unimplemented and read as '11'.

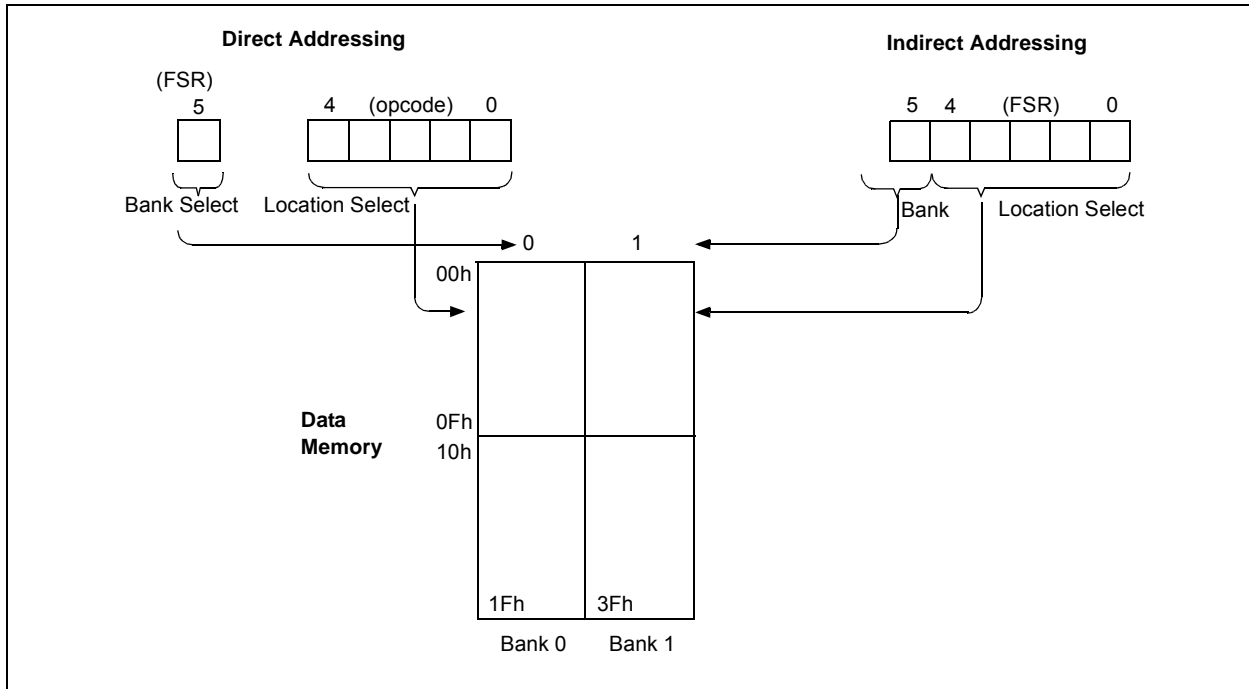
### EXAMPLE 4-1: HOW TO CLEAR RAM USING INDIRECT ADDRESSING

```

MOV LW 0x10 ;initialize pointer
MOV WF FSR ;to RAM
NEXT CLR F INDF ;clear INDF
;register
INCF FSR,F ;inc pointer
BT FSC FSR,4 ;all done?
GOTO NEXT ;NO, clear next
CONTINUE
: ;YES, continue
:

```

FIGURE 4-4: DIRECT/INDIRECT ADDRESSING



## 5.0 FLASH DATA MEMORY CONTROL

The Flash data memory is readable and writable during normal operation (full VDD range). This memory is not directly mapped in the register file space. Instead, it is indirectly addressed through the Special Function Registers (SFRs).

### 5.1 Reading Flash Data Memory

To read a Flash data memory location the user must:

- Write the EEADR register
- Set the RD bit of the EECON register

The value written to the EEADR register determines which Flash data memory location is read. Setting the RD bit of the EECON register initiates the read. Data from the Flash data memory read is available in the EEDATA register immediately. The EEDATA register will hold this value until another read is initiated or it is modified by a write operation. Program execution is suspended while the read cycle is in progress. Execution will continue with the instruction following the one that sets the WR bit. See Example 1 for sample code.

#### EXAMPLE 1: READING FROM FLASH DATA MEMORY

```
BANKSEL EEADR      ;
MOVWF DATA_EE_ADDR, W ;
MOVWF EEADR        ;Data Memory
                   ;Address to read

BANKSEL EECON1     ;

BSF EECON, RD      ;EE Read
MOVWF EEDATA, W    ;W = EEDATA
```

**Note:** Only a BSF command will work to enable the Flash data memory read documented in Example 1. No other sequence of commands will work, no exceptions.

### 5.2 Writing and Erasing Flash Data Memory

Flash data memory is erased one row at a time and written one byte at a time. The 64-byte array is made up of eight rows. A row contains eight sequential bytes. Row boundaries exist every eight bytes.

Generally, the procedure to write a byte of data to Flash data memory is:

1. Identify the row containing the address where the byte will be written.
2. If there is other information in that row that must be saved, copy those bytes from Flash data memory to RAM.
3. Perform a row erase of the row of interest.

4. Write the new byte of data and any saved bytes back to the appropriate addresses in Flash data memory.

To prevent accidental corruption of the Flash Data Memory, an unlock sequence is required to initiate a write or erase cycle. This sequence requires that the bit set instructions used to configure the EECON register happen exactly as shown in Example 2 and Example 3, depending on the operation requested.

#### 5.2.1 ERASING FLASH DATA MEMORY

A row must be manually erased before writing new data. The following sequence must be performed for a single row erase.

1. Load EEADR with an address in the row to be erased.
2. Set the FREE bit to enable the erase.
3. Set the WREN bit to enable write access to the array.
4. Set the WR bit to initiate the erase cycle.

If the WREN bit is not set in the instruction cycle after the FREE bit is set, the FREE bit will be cleared in hardware.

If the WR bit is not set in the instruction cycle after the WREN bit is set, the WREN bit will be cleared in hardware.

Sample code that follows this procedure is included in Example 2.

Program execution is suspended while the erase cycle is in progress. Execution will continue with the instruction following the one that sets the WR bit.

#### EXAMPLE 2: ERASING A FLASH DATA MEMORY ROW

```
BANKSEL EEADR
MOVLW EE_ADR_ERASE ; LOAD ADDRESS OF ROW TO
                   ; ERASE
MOVWF EEADR ;
BSF EECON, FREE ; SELECT ERASE
BSF EECON, WREN ; ENABLE WRITES
BSF EECON, WR ; INITIATE ERASE
```

**Note 1:** The FREE bit may be set by any command normally used by the core. However, the WREN and WR bits can only be set using a series of BSF commands, as documented in Example 1. No other sequence of commands will work, no exceptions.

**2:** Bits <5:3> of the EEADR register indicate which row is to be erased.

# PIC12F519

## 5.2.2 WRITING TO FLASH DATA MEMORY

Once a cell is erased, new data can be written. Program execution is suspended during the write cycle. The following sequence must be performed for a single byte write.

1. Load EEADR with the address.
2. Load EEDATA with the data to write.
3. Set the WREN bit to enable write access to the array.
4. Set the WR bit to initiate the erase cycle.

If the WR bit is not set in the instruction cycle after the WREN bit is set, the WREN bit will be cleared in hardware.

Sample code that follows this procedure is included in Example 3.

### EXAMPLE 3: WRITING A FLASH DATA MEMORY ROW

```
BANKSEL    EEADR
MOVLW     EE_ADR_WRITE    ; LOAD ADDRESS
MOVWF     EEADR           ;
MOVLW     EE_DATA_TO_WRITE ; LOAD DATA
MOVWF     EEDATA          ; INTO EEDATA REGISTER
BSF       EECON,WREN      ; ENABLE WRITES
BSF       EECON,WR        ; INITITATE ERASE
```

**Note 1:** Only a series of BSF commands will work to enable the memory write sequence documented in Example 2. No other sequence of commands will work, no exceptions.

- 2: For reads, erases and writes to the Flash data memory, there is no need to insert a NOP into the user code as is done on mid-range devices. The instruction immediately following the “BSF EECON,WR/RD” will be fetched and executed properly.

## 5.3 Write Verify

Depending on the application, good programming practice may dictate that data written to the Flash data memory be verified. Example 4 is an example of a write verify.

### EXAMPLE 4: WRITE VERIFY OF DATA EEPROM

```
MOVF      EEDATA, W      ;EEDATA has not changed
                                ;from previous write
BSF       EECON, RD      ;Read the value written
XORWF     EEDATA, W      ;
BTFSS     STATUS, Z      ;Is data the same
GOTO      WRITE_ERR      ;No, handle error
                                ;Yes, continue
```

## 5.4 Code Protection

Code protection does not prevent the CPU from performing read or write operations on the Flash data memory. Refer to the code protection chapter for more information.



## 6.0 I/O PORT

As with any other register, the I/O register(s) can be written and read under program control. However, read instructions (e.g., `MOVF PORTB, W`) always read the I/O pins independent of the pin's Input/Output modes. On Reset, all I/O ports are defined as input (inputs are at high-impedance) since the I/O control registers are all set.

### 6.1 GPIO

GPIO is an 8-bit I/O register. Only the low-order 6 bits are used (GP<5:0>). Bits 7 and 6 are unimplemented and read as '0's. Please note that GP3 is an input-only pin. The Configuration Word can set several I/O's to alternate functions. When acting as alternate functions, the pins will read as '0' during a port read. Pins GP0, GP1, and GP3 can be configured with weak pull-ups and also for wake-up on change. The wake-up on change and weak pull-up functions are not pin selectable. If GP3/MCLR is configured as MCLR, weak pull-up is always on and wake-up on change for this pin is not enabled.

## 6.2 TRIS Registers

The Output Driver Control registers are loaded with the contents of the W Register by executing the `TRIS F` instruction. A '1' from a TRISGPIO Register bit puts the corresponding output driver in a high-impedance (Input) mode. A '0' puts the contents of the output data latch on the selected pins, enabling the output buffer.

The TRISGPIO register is "write-only". Bits <5:0> are set (output drivers disabled) upon Reset.

**Note:** If the T0CS bit is set to '1', it will override the TRISGPIO function on the T0CKI pin.

**TABLE 6-1: WEAK PULL-UP ENABLED PINS**

Pin	WPU	WU
GP0	Y	Y
GP1	Y	Y
GP2	N	N
GP3	Y <sup>(1)</sup>	Y
GP4	N	N
GP5	N	N
GP6	N	N

**Note 1:** When MCLRE = 1, the weak pull-up on GP3/MCLR is always enabled.

**2:** WPU = Weak pull-up; WU = Wake-up.

# PIC12F519

## REGISTER 6-1: GPIO: GPIO REGISTER

U-0	U-0	R/W-x	R/W-x	R/W-x	R/W-x	R/W-x	R/W-x
—	—	GP5	GP4	GP3	GP2	GP1	GP0
bit 7							bit 0

**Legend:**

R = Readable bit                      W = Writable bit                      U = Unimplemented bit, read as '0'  
 -n = Value at POR                      '1' = Bit is set                      '0' = Bit is cleared                      x = Bit is unknown

bit 7-6                      **Unimplemented:** Read as '0'

bit 5-0                      **GP<5:0>:** GPIO I/O Pin bits  
 1 = GPIO pin is >V<sub>IH</sub> min.  
 0 = GPIO pin is <V<sub>IL</sub> max.

## REGISTER 6-2: TRISGPIO: TRI-STATE GPIO REGISTER

U-0	U-0	W-1	W-1	W-1	W-1	W-1	W-1
—	—	TRISGPIO5	TRISGPIO4	TRISGPIO3	TRISGPIO2	TRISGPIO1	TRISGPIO0
bit 7							bit 0

**Legend:**

R = Readable bit                      W = Writable bit                      U = Unimplemented bit, read as '0'  
 -n = Value at POR                      '1' = Bit is set                      '0' = Bit is cleared                      x = Bit is unknown

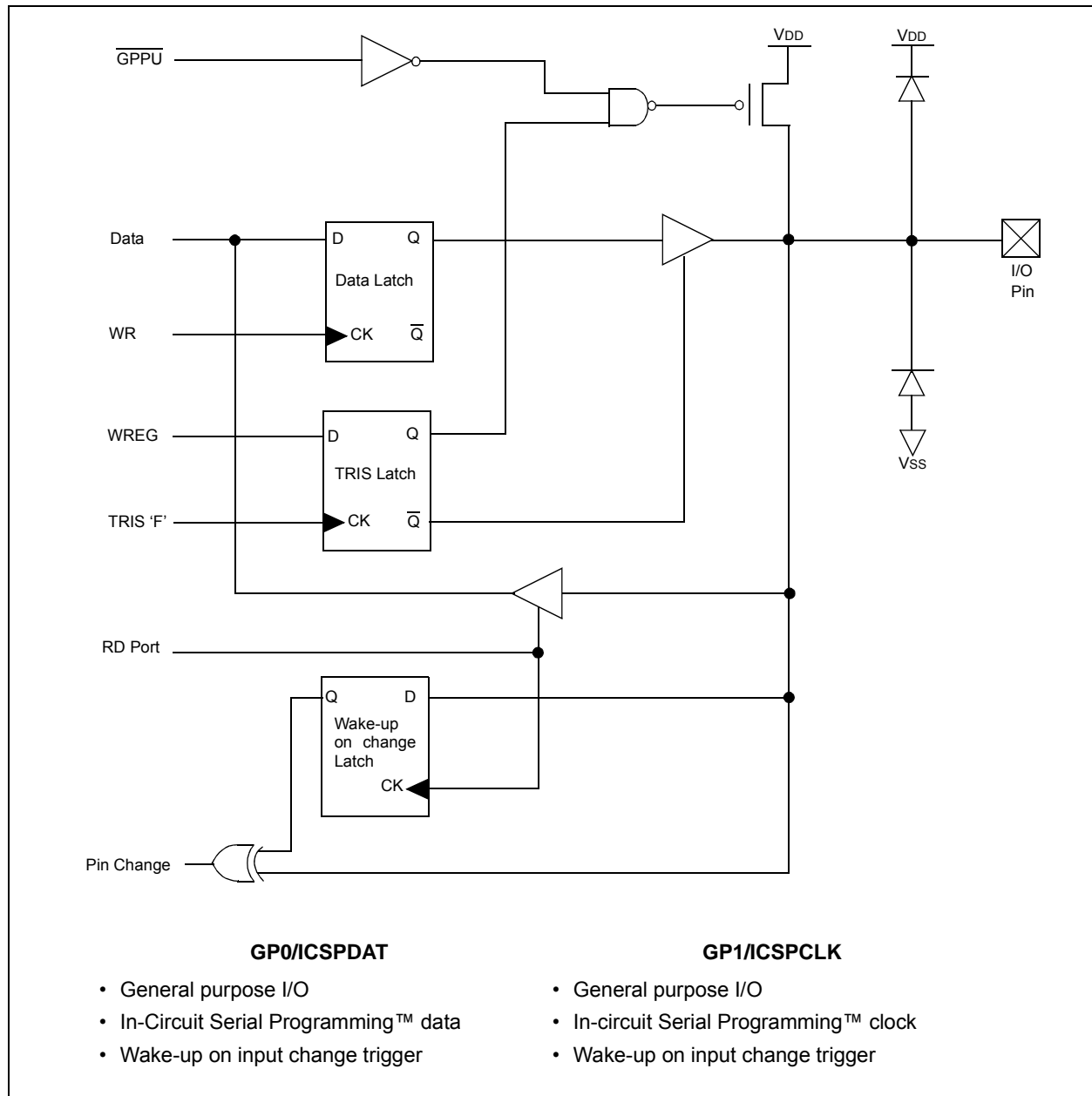
bit 7-6                      **Unimplemented:** Read as '0'

bit 5-0                      **TRISGPIO<5:0>:** GPIO Tri-State Control bits  
 1 = GPIO pin configured as an input (tri-stated)  
 0 = GPIO pin configured as an output

## 6.3 I/O Interfacing

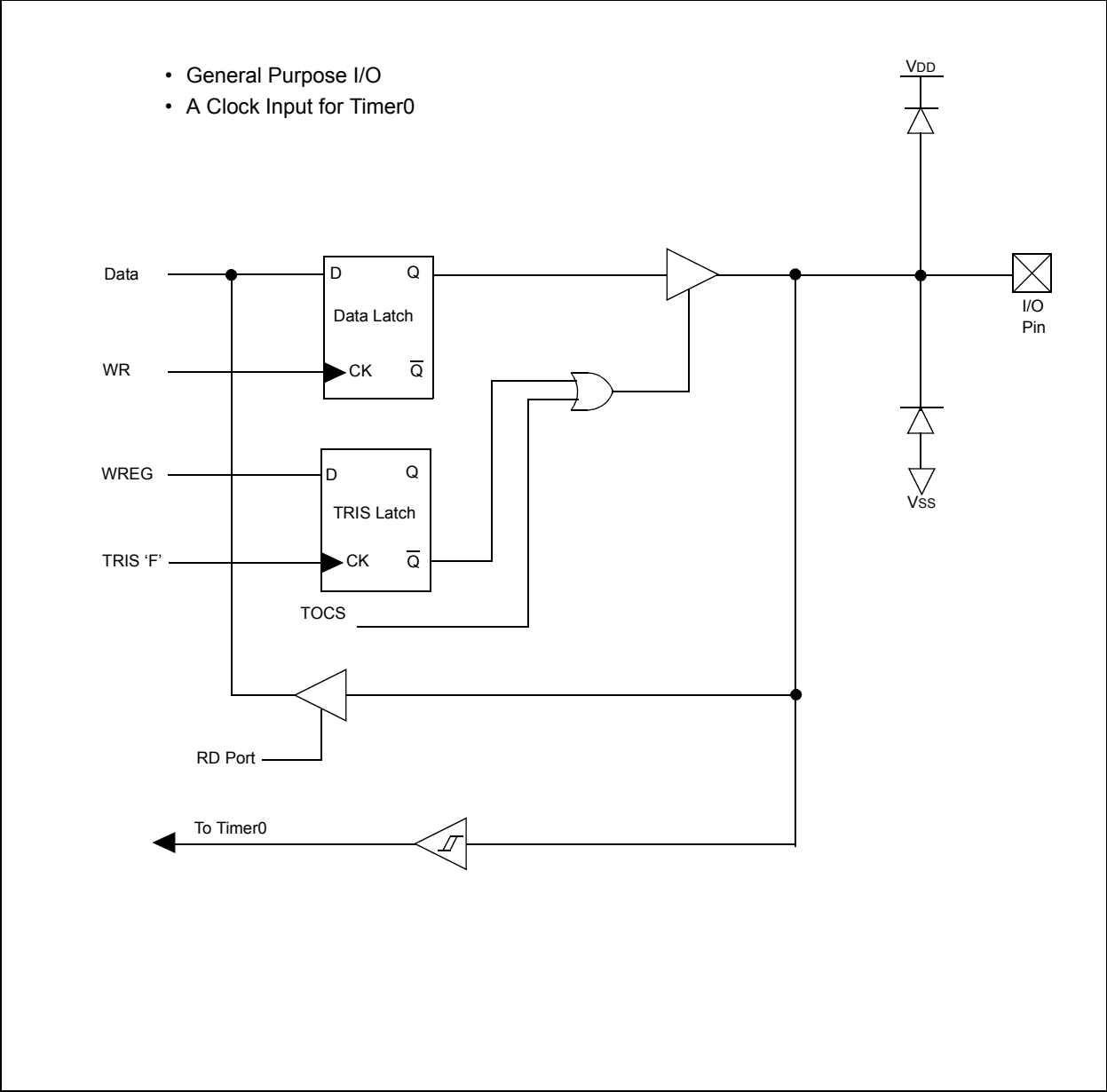
The equivalent circuit for an I/O port pin is shown in Figure 6-1. All port pins, except GP3 which is input only, may be used for both input and output operations. For input operations, these ports are non-latching. Any input must be present until read by an input instruction (e.g., `MOVF GPIO, W`). The outputs are latched and remain unchanged until the output latch is rewritten. To use a port pin as output, the corresponding direction control bit in TRISGPIO must be cleared (= 0). For use as an input, the corresponding TRISGPIO bit must be set. Any I/O pin (except GP3) can be programmed individually as input or output.

**FIGURE 6-1: PIC12F519 EQUIVALENT CIRCUIT FOR I/O PINS – GP0/GP1**



# PIC12F519

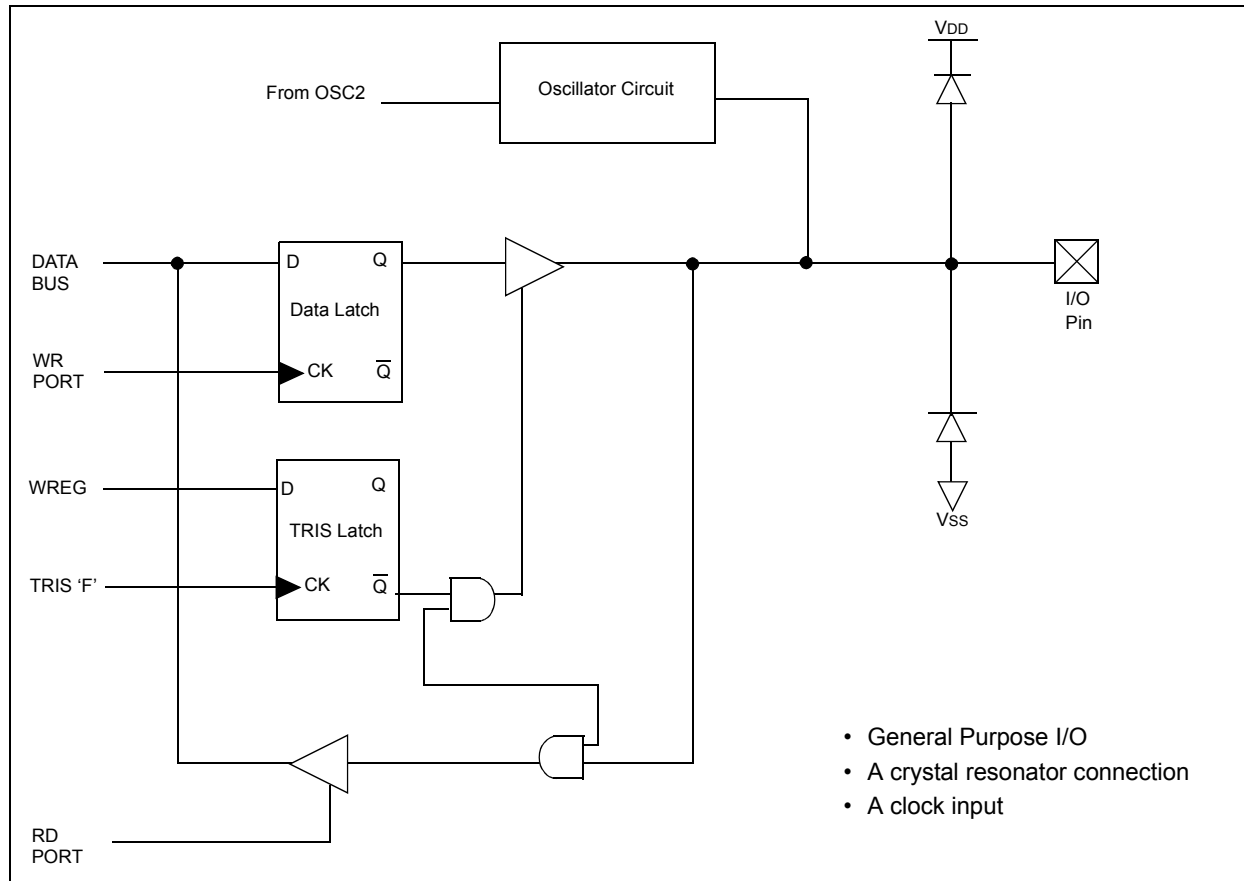
FIGURE 6-2: GP2/TOCK1



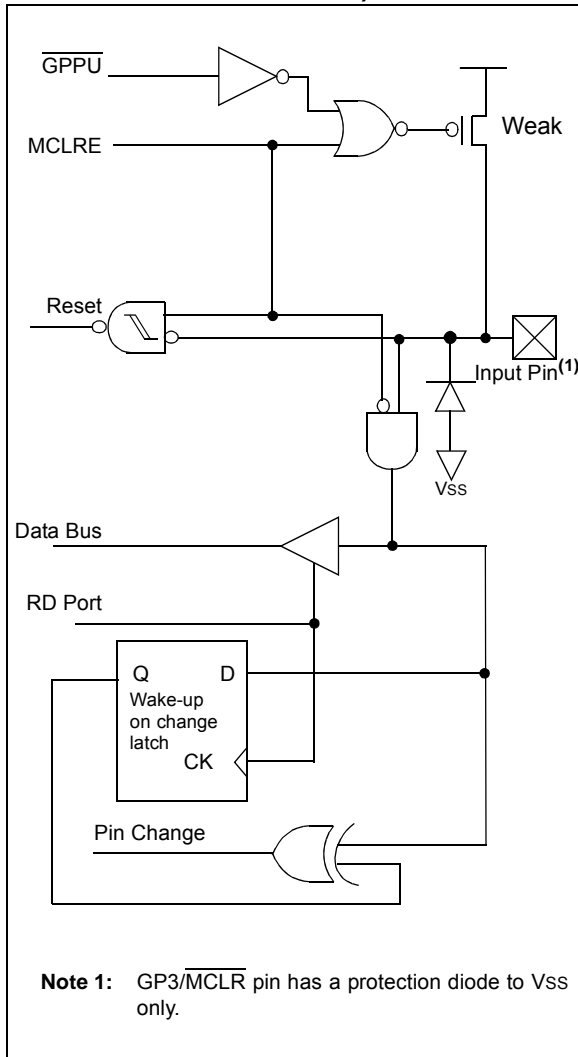


# PIC12F519

FIGURE 6-4: GP5/OSC1/CLKIN



**FIGURE 6-5: GP3 (WITH WEAK PULL-UP AND WAKE-UP ON CHANGE)**



**TABLE 6-2: SUMMARY OF PORT REGISTERS**

Name	Bit 7	Bit 6	Bit 5	Bit 4	Bit 3	Bit 2	Bit 1	Bit 0	Value on POR	Value on all other Resets
GPIO	—	—	GP5	GP4	GP3	GP2	GP1	GP0	--xx xxxx	--uu uuuu
TRISGPIO	—	—	TRISGPIO5	TRISGPIO4	TRISGPIO3	TRISGPIO2	TRISGPIO1	TRISGPIO0	--11 1111	--11 1111
STATUS	GPWUF	—	PA0	$\overline{TO}$	$\overline{PD}$	Z	DC	C	0-01 1xxx	q-0q quuu
OPTION	$\overline{GPWU}$	$\overline{GPPU}$	T0CS	T0SE	PSA	PS2	PS1	PS0	1111 1111	1111 1111

**Legend:** x = unknown, u = unchanged, — = unimplemented, read as '0', Shaded cells = unimplemented, read as '0', q = depends on the condition

# PIC12F519

## 6.4 I/O Programming Considerations

### 6.4.1 BIDIRECTIONAL I/O PORTS

Some instructions operate internally as read followed by write operations. The BCF and BSF instructions, for example, read the entire port into the CPU, execute the bit operation and re-write the result. Caution must be used when these instructions are applied to a port where one or more pins are used as input/outputs. For example, a BSF operation on bit 5 of GPIO will cause all eight bits of GPIO to be read into the CPU, bit 5 to be set and the GPIO value to be written to the output latches. If another bit of GPIO is used as a bidirectional I/O pin (say bit 0) and it is defined as an input at this time, the input signal present on the pin itself would be read into the CPU and rewritten to the data latch of this particular pin, overwriting the previous content. As long as the pin stays in the Input mode, no problem occurs. However, if bit 0 is switched into Output mode later on, the content of the data latch may now be unknown.

Example 6-1 shows the effect of two sequential Read-Modify-Write instructions (e.g., BCF, BSF, etc.) on an I/O port.

A pin actively outputting a high or a low should not be driven from external devices at the same time in order to change the level on this pin (“wired OR”, “wired AND”). The resulting high output currents may damage the chip.

### EXAMPLE 6-1: READ-MODIFY-WRITE INSTRUCTIONS ON AN I/O PORT

```

;Initial GPIO Settings
;GPIO<5:3> Inputs
;GPIO<2:0> Outputs
;
;
;           GPIO latch  GPIO pins
;           -----  -----
BCF  GPIO, 5  ;--01 -ppp  --11 pppp
BCF  GPIO, 4  ;--10 -ppp  --11 pppp
MOVLW 007h;
TRIS  GPIO   ;--10 -ppp  --11 pppp
;

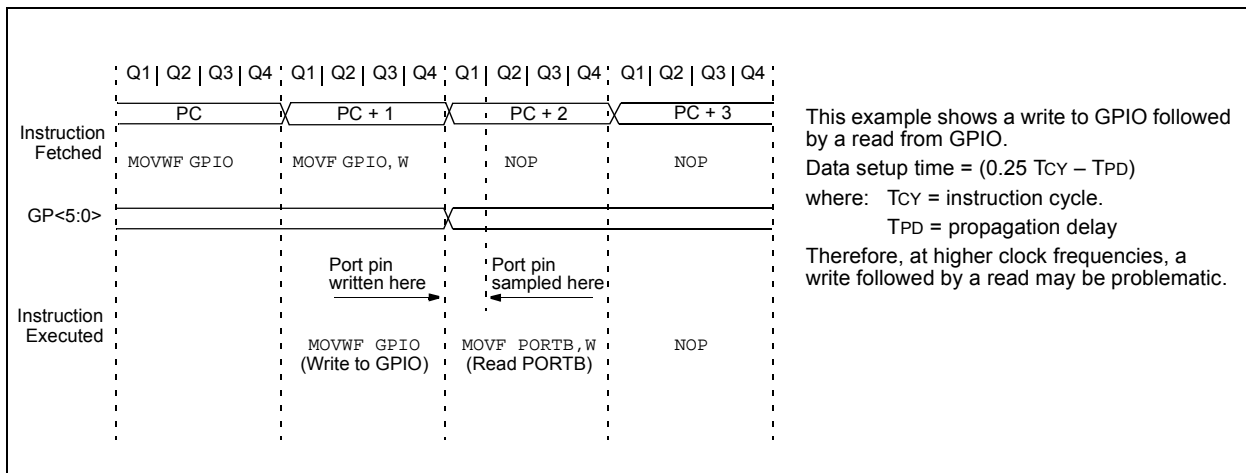
```

**Note 1:** The user may have expected the pin values to be ‘--00 pppp’. The 2nd BCF caused GP5 to be latched as the pin value (High).

### 6.4.2 SUCCESSIVE OPERATIONS ON I/O PORTS

The actual write to an I/O port happens at the end of an instruction cycle, whereas for reading, the data must be valid at the beginning of the instruction cycle (Figure 6-6). Therefore, care must be exercised if a write followed by a read operation is carried out on the same I/O port. The sequence of instructions should allow the pin voltage to stabilize (load dependent) before the next instruction causes that pin to be read into the CPU. Otherwise, the previous state of that pin may be read into the CPU rather than the new state. When in doubt, it is better to separate these instructions with a NOP or another instruction not accessing this I/O port.

**FIGURE 6-6: SUCCESSIVE I/O OPERATION**





## 7.0 TIMER0 MODULE AND TMR0 REGISTER

The Timer0 module has the following features:

- 8-bit timer/counter register, TMR0
- Readable and writable
- 8-bit software programmable prescaler
- Internal or external clock select:
  - Edge select for external clock

Figure 7-1 is a simplified block diagram of the Timer0 module.

Timer mode is selected by clearing the T0CS bit (OPTION<5>). In Timer mode, the Timer0 module will increment every instruction cycle (without prescaler). If TMR0 register is written, the increment is inhibited for the following two cycles (Figure 7-2 and Figure 7-3). The user can work around this by writing an adjusted value to the TMR0 register.

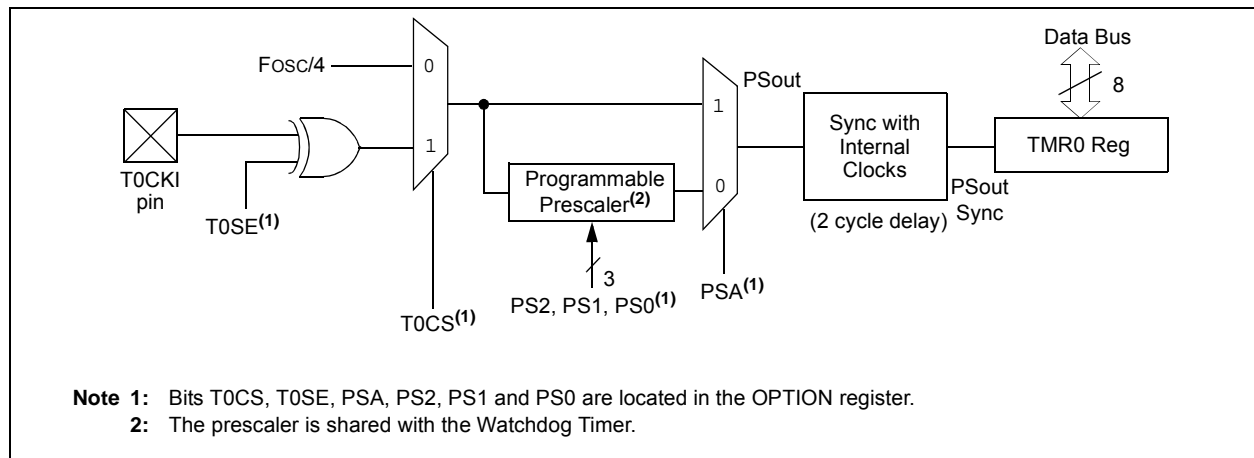
Counter mode is selected by setting the T0CS bit (OPTION<5>). In this mode, Timer0 will increment either on every rising or falling edge of pin T0CKI. The T0SE bit (OPTION<4>) determines the source edge. Clearing the T0SE bit selects the rising edge. Restrictions on the external clock input are discussed in detail in **Section 7.1 “Using Timer0 with an External Clock”**.

The prescaler may be used by either the Timer0 module or the Watchdog Timer, but not both. The prescaler assignment is controlled in software by the control bit, PSA (OPTION<3>). Clearing the PSA bit will assign the prescaler to Timer0. The prescaler is not readable or writable. When the prescaler is assigned to the Timer0 module, prescale values of 1:2, 1:4, ..., 1:256 are selectable. **Section 7.2 “Prescaler”** details the operation of the prescaler.

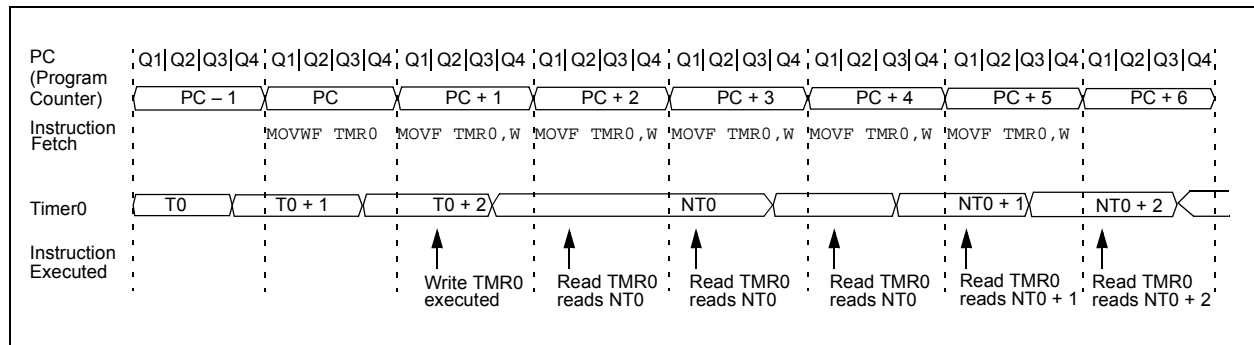
A summary of registers associated with the Timer0 module is found in Table 7-1.

The Timer0 contained in the CPU core follows the standard baseline definition.

**FIGURE 7-1: TIMER0 BLOCK DIAGRAM**

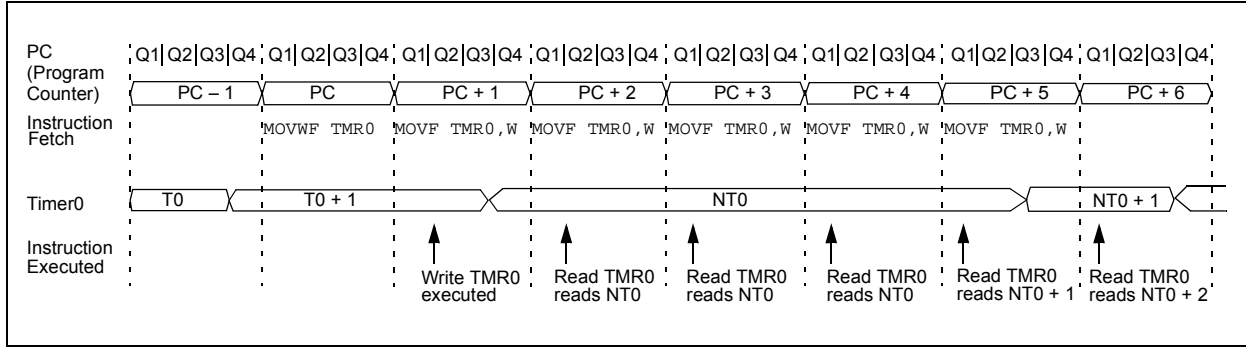


**FIGURE 7-2: TIMER0 TIMING: INTERNAL CLOCK/NO PRESCALE**



# PIC12F519

**FIGURE 7-3: TIMER0 TIMING: INTERNAL CLOCK/PRESCALE 1:2**



**TABLE 7-1: REGISTERS ASSOCIATED WITH TIMER0**

Add res s	Name	Bit 7	Bit 6	Bit 5	Bit 4	Bit 3	Bit 2	Bit 1	Bit 0	Value on Power-on Reset	Value on All Other Resets
01h	TMR0	Timer0 – 8-bit Real-Time Clock/Counter								xxxx xxxx	uuuu uuuu
N/A	OPTION	$\overline{\text{GPWU}}$	$\overline{\text{GPPU}}$	T0CS	T0SE	PSA	PS2	PS1	PS0	1111 1111	1111 1111
N/A	TRISGPIO	—	—	TRISGPIO5	TRISGPIO4	TRISGPIO3	TRISGPIO2	TRISGPIO1	TRISGPIO0	--11 1111	--11 1111

**Legend:** x = unknown, u = unchanged, – = unimplemented, read as '0', Shaded cells = unimplemented, read as '0'

## 7.1 Using Timer0 with an External Clock

When an external clock input is used for Timer0, it must meet certain requirements. The external clock requirement is due to internal phase clock (Tosc) synchronization. Also, there is a delay in the actual incrementing of Timer0 after synchronization.

### 7.1.1 EXTERNAL CLOCK SYNCHRONIZATION

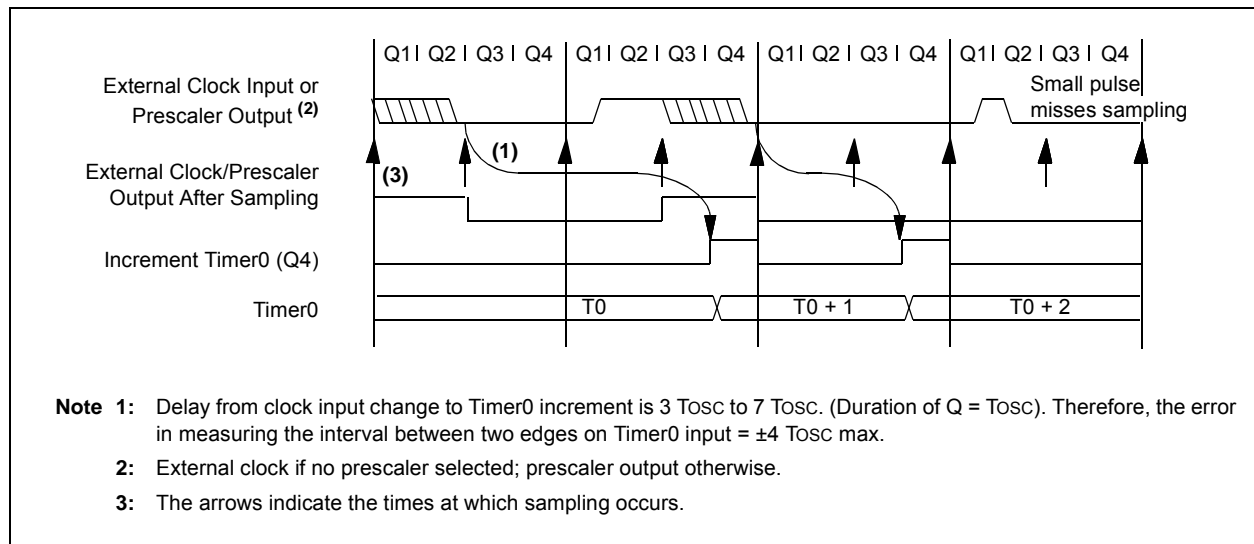
When no prescaler is used, the external clock input is the same as the prescaler output. The synchronization of T0CKI with the internal phase clocks is accomplished by sampling the prescaler output on the Q2 and Q4 cycles of the internal phase clocks (Figure 7-4). Therefore, it is necessary for T0CKI to be high for at least 2 Tosc (and a small RC delay of 2 Tt0H) and low for at least 2 Tosc (and a small RC delay of 2 Tt0H). Refer to the electrical specification of the desired device.

When a prescaler is used, the external clock input is divided by the asynchronous ripple counter-type prescaler, so that the prescaler output is symmetrical. For the external clock to meet the sampling requirement, the ripple counter must be taken into account. Therefore, it is necessary for T0CKI to have a period of at least 4 Tosc (and a small RC delay of 4 Tt0H) divided by the prescaler value. The only requirement on T0CKI high and low time is that they do not violate the minimum pulse width requirement of Tt0H. Refer to parameters 40, 41 and 42 in the electrical specification of the desired device.

### 7.1.2 TIMER0 INCREMENT DELAY

Since the prescaler output is synchronized with the internal clocks, there is a small delay from the time the external clock edge occurs to the time the Timer0 module is actually incremented. Figure 7-4 shows the delay from the external clock edge to the timer incrementing.

**FIGURE 7-4: TIMER0 TIMING WITH EXTERNAL CLOCK**



# PIC12F519

## 7.2 Prescaler

An 8-bit counter is available as a prescaler for the Timer0 module or as a postscaler for the Watchdog Timer (WDT), respectively (see **Section 8.6 “Watchdog Timer (WDT)”**). For simplicity, this counter is being referred to as “prescaler” throughout this data sheet.

**Note:** The prescaler may be used by either the Timer0 module or the WDT, but not both. Thus, a prescaler assignment for the Timer0 module means that there is no prescaler for the WDT and vice versa.

The PSA and PS<2:0> bits (OPTION<3:0>) determine prescaler assignment and prescale ratio.

When assigned to the Timer0 module, all instructions writing to the TMR0 register (e.g., CLRWF TMR0, MOVWF TMR0, etc.) will clear the prescaler. When assigned to WDT, a CLRWDT instruction will clear the prescaler along with the WDT. The prescaler is neither readable nor writable. On a Reset, the prescaler contains all '0's.

### 7.2.1 SWITCHING PRESCALER ASSIGNMENT

The prescaler assignment is fully under software control (i.e., it can be changed “on-the-fly” during program execution). To avoid an unintended device Reset, the following instruction sequence (Example 7-1) must be executed when changing the prescaler assignment from Timer0 to the WDT.

### EXAMPLE 7-1: CHANGING PRESCALER (TIMER0 → WDT)

```
CLRWDT          ;Clear WDT
CLRWF  TMR0     ;Clear TMR0 and Prescaler
MOVLW  b'00xx1111'
OPTION

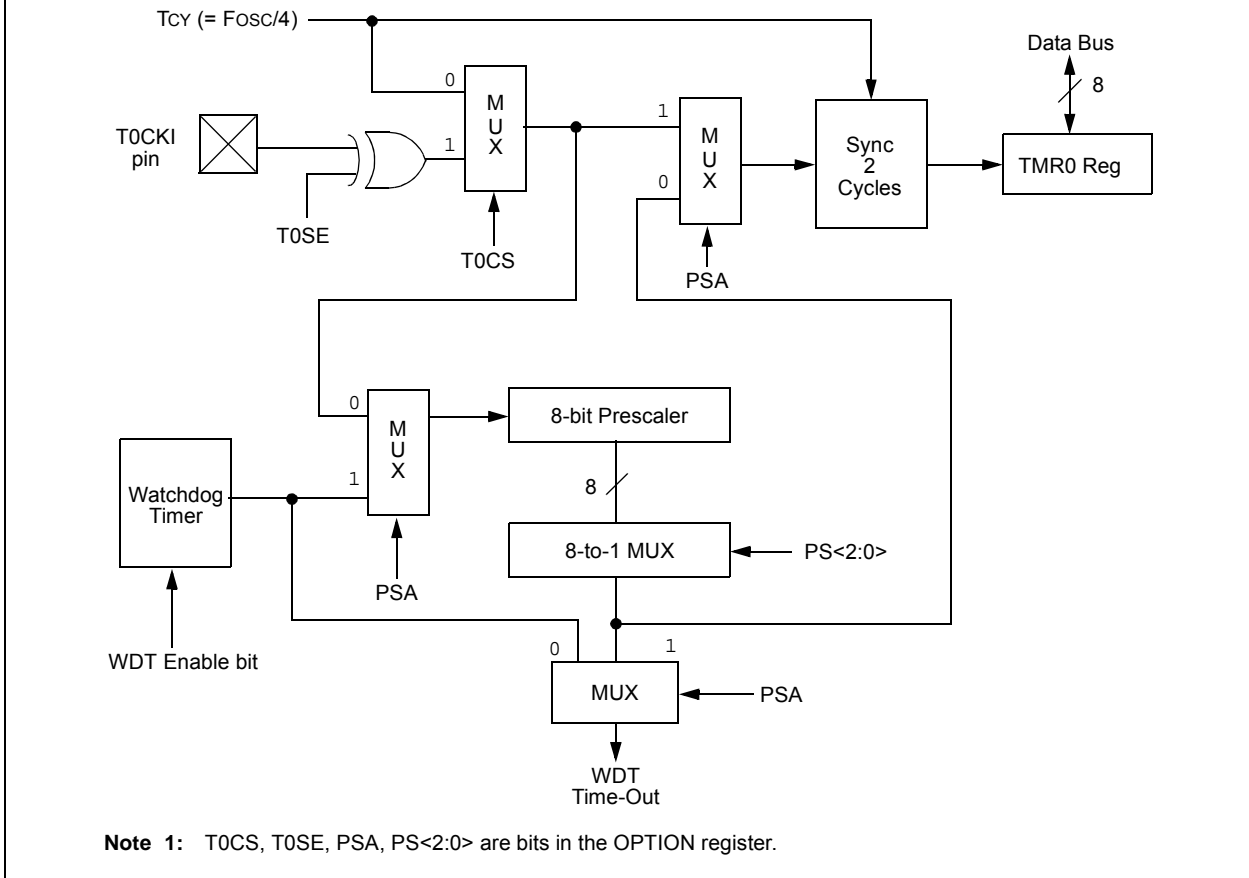
CLRWDT          ;PS<2:0> are 000 or 001
MOVLW  b'00xx1xxx' ;Set Postscaler to
OPTION          ;desired WDT rate
```

To change the prescaler from the WDT to the Timer0 module, use the sequence shown in Example 7-2. This sequence must be used even if the WDT is disabled. A CLRWDT instruction should be executed before switching the prescaler.

### EXAMPLE 7-2: CHANGING PRESCALER (WDT → TIMER0)

```
CLRWDT          ;Clear WDT and
                ;prescaler
MOVLW  b'xxxx0xxx' ;Select TMR0, new
                ;prescale value and
                ;clock source
OPTION
```

FIGURE 7-5: BLOCK DIAGRAM OF THE TIMER0/ WDT PRESCALER<sup>(1)</sup>



# PIC12F519

---

NOTES:

## 8.0 SPECIAL FEATURES OF THE CPU

What sets a microcontroller apart from other processors are special circuits that deal with the needs of real-time applications. The PIC12F519 microcontroller has a host of such features intended to maximize system reliability, minimize cost through elimination of external components, provide power-saving operating modes and offer code protection. These features are:

- Oscillator Selection
- Reset:
  - Power-on Reset (POR)
  - Device Reset Timer (DRT)
  - Wake-up from Sleep on Pin Change
- Watchdog Timer (WDT)
- Sleep
- Code Protection
- ID Locations
- In-Circuit Serial Programming™

The PIC12F519 device has a Watchdog Timer, which can be shut off only through Configuration bit WDTE. It runs off of its own RC oscillator for added reliability. If using XT or LP selectable oscillator options, there is always an 18 ms (nominal) delay provided by the Device Reset Timer (DRT), intended to keep the chip in Reset until the crystal oscillator is stable. If using INTRC or EXTRC, the DRT provides a 1 ms (nominal) delay.

The Sleep mode is designed to offer a very low-current Power-Down mode. The user can wake-up from Sleep through a change-on-input-pins or through a Watchdog Timer time-out. Several oscillator options are also made available to allow the part to fit the application, including an internal 4 MHz or 8 MHz oscillator. The EXTRC oscillator option saves system cost while the LP crystal option saves power. A set of Configuration bits are used to select various options.

### 8.1 Configuration Bits

The PIC12F519 Configuration Words consist of 12 bits. Configuration bits can be programmed to select various device configurations. Two bits are for the selection of the oscillator type; one bit is the Watchdog Timer enable bit, one bit is the MCLR enable bit and one bit is for code protection (Register 8-1).

# PIC12F519

## REGISTER 8-1: CONFIG: CONFIGURATION WORD REGISTER<sup>(1)</sup>

—	$\overline{\text{CPDF}}$	IOSCFS	MCLRE	$\overline{\text{CP}}$	WDTE	FOSC1	FOSC0
bit 7							bit 0

- bit 7      **Unimplemented:** Read as '1'
- bit 6       **$\overline{\text{CPDF}}$ :** Code Protection bit - Flash Data Memory  
1 = Code protection off  
0 = Code protection on
- bit 5      **IOSCFS:** Internal Oscillator Frequency Select bit  
1 = 8 MHz INTOSC frequency  
0 = 4 MHz INTOSC frequency
- bit 4      **MCLRE:** Master Clear Enable bit  
1 = GP3/ $\overline{\text{MCLR}}$  pin functions as  $\overline{\text{MCLR}}$   
0 = GP3/ $\overline{\text{MCLR}}$  pin functions as GP3,  $\overline{\text{MCLR}}$  internally tied to VDD
- bit 3       **$\overline{\text{CP}}$ :** Code Protection bit - User Program Memory  
1 = Code protection off  
0 = Code protection on
- bit 2      **WDTE:** Watchdog Timer Enable bit  
1 = WDT enabled  
0 = WDT disabled
- bit 1-0    **FOSC<1:0>:** Oscillator Selection bits  
00 = LP oscillator with 18 ms DRT<sup>(2)</sup>  
01 = XT oscillator with 18 ms DRT<sup>(2)</sup>  
10 = INTOSC with 1 ms DRT<sup>(2)</sup>  
11 = EXTRC with 1 ms DRT<sup>(2)</sup>

**Note 1:** Refer to the "PIC12F519 Memory Programming Specification", DS41316 to determine how to program/erase the Configuration Word.

- 2:** DRT length (18 ms or 1 ms) is a function of clock mode selection. It is the responsibility of the application designer to ensure the use of either 18 ms (nominal) DRT or the 1 ms (nominal) DRT will result in acceptable operation. Refer to Figure 11-1 and Table 11-2 for VDD rise time and stability requirements for this mode of operation.



## 8.2 Oscillator Configurations

### 8.2.1 OSCILLATOR TYPES

The PIC12F519 device can be operated in up to four different oscillator modes. The user can program using the Configuration bits (FOSC<1:0>), to select one of these modes:

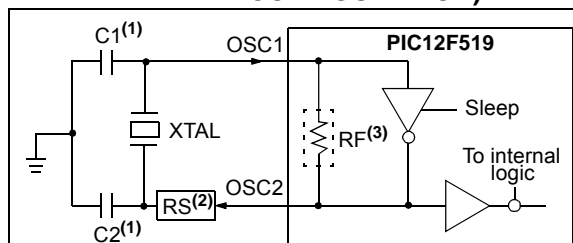
- LP: Low-Power Crystal
- XT: Crystal/Resonator
- INTRC: Internal 4 MHz or 8 MHz Oscillator
- EXTRC: External Resistor/Capacitor

### 8.2.2 CRYSTAL OSCILLATOR/CERAMIC RESONATORS

In XT or LP modes, a crystal or ceramic resonator is connected to the (GP5)/OSC1/(CLKIN) and (GP4)/OSC2 pins to establish oscillation (Figure 8-1). The PIC12F519 oscillator designs require the use of a parallel cut crystal. Use of a series cut crystal may give a frequency out of the crystal manufacturers specifications. When in XT or LP modes, the device can have an external clock source drive the (GP5)/OSC1/CLKIN pin (Figure 8-2). When the part is used in this fashion, the output drive levels on the OSC2 pin are very weak. This pin should be left open and unloaded. Also when using this mode, the external clock should observe the frequency limits for the clock mode chosen (XT or LP).

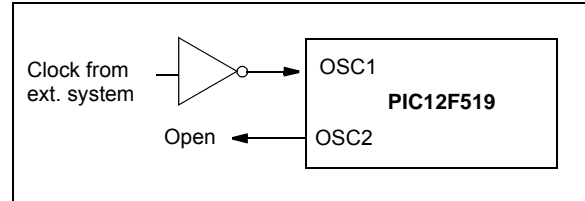
**Note 1:** The user should verify that the device oscillator starts and performs as expected. Adjusting the loading capacitor values and/or the Oscillator mode may be required.

**FIGURE 8-1: CRYSTAL OPERATION (OR CERAMIC RESONATOR) (XT OR LP OSC CONFIGURATION)**



- Note 1:** See Capacitor Selection tables for recommended values of C1 and C2.
- Note 2:** A series resistor (RS) may be required for AT strip cut crystals.
- Note 3:** RF approx. value = 10 MΩ.

**FIGURE 8-2: EXTERNAL CLOCK INPUT OPERATION (XT OR LP OSC CONFIGURATION)**



**TABLE 8-1: CAPACITOR SELECTION FOR CERAMIC RESONATORS**

Osc Type	Resonator Freq.	Cap. Range C1	Cap. Range C2
XT	4.0 MHz	30 pF	30 pF

**Note:** Component values shown are for design guidance only. Since each resonator has its own characteristics, the user should consult the resonator manufacturer for appropriate values of external components.

**TABLE 8-2: CAPACITOR SELECTION FOR CRYSTAL OSCILLATOR – PIC12F519(2)**

Osc Type	Resonator Freq.	Cap. Range C1	Cap. Range C2
LP	32 kHz <sup>(1)</sup>	15 pF	15 pF
XT	200 kHz	47-68 pF	47-68 pF
	1 MHz	15 pF	15 pF
	4 MHz	15 pF	15 pF

- Note 1:** For VDD > 4.5V, C1 = C2 ≈ 30 pF is recommended.
- Note 2:** Component values shown are for design guidance only. Rs may be required to avoid overdriving crystals with low drive level specification. Since each crystal has its own characteristics, the user should consult the crystal manufacturer for appropriate values of external components.

# PIC12F519

## 8.2.3 EXTERNAL CRYSTAL OSCILLATOR CIRCUIT

Either a prepackaged oscillator or a simple oscillator circuit with TTL gates can be used as an external crystal oscillator circuit. Prepackaged oscillators provide a wide operating range and better stability. A well-designed crystal oscillator will provide good performance with TTL gates. Two types of crystal oscillator circuits can be used: one with parallel resonance, or one with series resonance.

Figure 8-3 shows implementation of a parallel resonant oscillator circuit. The circuit is designed to use the fundamental frequency of the crystal. The 74AS04 inverter performs the 180-degree phase shift that a parallel oscillator requires. The 4.7 k $\Omega$  resistor provides the negative feedback for stability. The 10 k $\Omega$  potentiometers bias the 74AS04 in the linear region. This circuit could be used for external oscillator designs.

**FIGURE 8-3: EXTERNAL PARALLEL RESONANT CRYSTAL OSCILLATOR CIRCUIT**

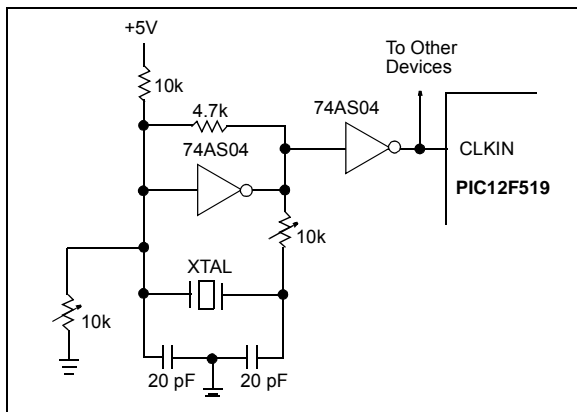
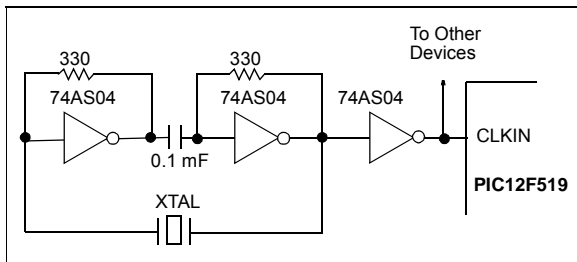


Figure 8-4 shows a series resonant oscillator circuit. This circuit is also designed to use the fundamental frequency of the crystal. The inverter performs a 180-degree phase shift in a series resonant oscillator circuit. The 330 $\Omega$  resistors provide the negative feedback to bias the inverters in their linear region.

**FIGURE 8-4: EXTERNAL SERIES RESONANT CRYSTAL OSCILLATOR CIRCUIT**



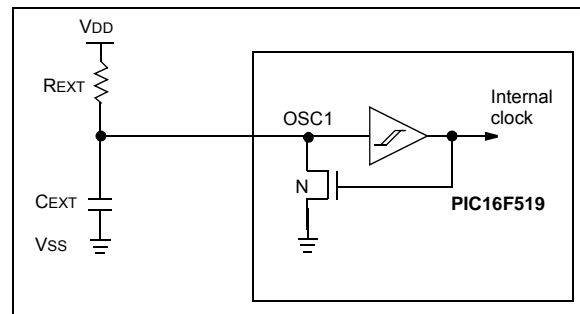
## 8.2.4 EXTERNAL RC OSCILLATOR

For timing insensitive applications, the RC circuit option offers additional cost savings. The RC oscillator frequency is a function of the supply voltage, the resistor (R<sub>EXT</sub>) and capacitor (C<sub>EXT</sub>) values, and the operating temperature. In addition to this, the oscillator frequency will vary from unit-to-unit due to normal process parameter variation. Furthermore, the difference in lead frame capacitance between package types will also affect the oscillation frequency, especially for low C<sub>EXT</sub> values. The user also needs to take into account variation due to tolerance of external R and C components used.

Figure 8-5 shows how the R/C combination is connected to the PIC12F519 device. For R<sub>EXT</sub> values below 3.0 k $\Omega$ , the oscillator operation may become unstable, or stop completely. For very high R<sub>EXT</sub> values (e.g., 1 M $\Omega$ ), the oscillator becomes sensitive to noise, humidity and leakage. It is recommended keeping R<sub>EXT</sub> between 5.0 k $\Omega$  and 100 k $\Omega$ .

Although the oscillator will operate with no external capacitor (C<sub>EXT</sub> = 0 pF), it is recommended using values above 20 pF for noise and stability reasons. With no or small external capacitance, the oscillation frequency can vary dramatically due to changes in external capacitances, such as PCB trace capacitance or package lead frame capacitance. See Figure 11-1 and Figure 11-2.

**FIGURE 8-5: EXTERNAL RC OSCILLATOR MODE**



## 8.2.5 INTERNAL 4/8 MHz RC OSCILLATOR

The internal RC oscillator provides a fixed 4/8 MHz (nominal) system clock at V<sub>DD</sub> = 3.5V and 25°C, (see **Section 11.0 “Electrical Characteristics”** for information on variation over voltage and temperature).

In addition, a calibration instruction is programmed into the last address of memory, which contains the calibration value for the internal RC oscillator. This location is always non-code protected, regardless of the code-protect settings. This value is programmed as a MOVLW XX instruction where XX is the calibration value, and is placed at the Reset vector. This will load the W register with the calibration value upon Reset and the

PC will then roll over to the users program at address 0x000. The user then has the option of writing the value to the OSCCAL Register (05h) or ignoring it.

OSCCAL, when written to with the calibration value, will “trim” the internal oscillator to remove process variation from the oscillator frequency.

**Note:** Erasing the device will also erase the pre-programmed internal calibration value for the internal oscillator. The calibration value must be read prior to erasing the part so it can be reprogrammed correctly later.

For the PIC12F519 device, only bits <7:1> of OSCCAL are used for calibration. See Register 4-3 for more information.

**Note:** The bit 0 of the OSCCAL register is unimplemented and should be written as ‘0’ when modifying OSCCAL for compatibility with future devices.

## 8.3 Reset

The device differentiates between various kinds of Reset:

- Power-on Reset (POR)
- $\overline{\text{MCLR}}$  Reset during normal operation
- $\overline{\text{MCLR}}$  Reset during Sleep
- WDT Time-out Reset during normal operation
- WDT Time-out Reset during Sleep
- Wake-up from Sleep on pin change

Some registers are not reset in any way, and they are unknown on Power-on Reset (POR) and unchanged in any other Reset. Most other registers are reset to “Reset state” on Power-on Reset (POR),  $\overline{\text{MCLR}}$ , WDT or Wake-up on pin change Reset during normal operation. They are not affected by a WDT Reset during Sleep or  $\overline{\text{MCLR}}$  Reset during Sleep, since these Resets are viewed as resumption of normal operation. The exceptions to this are  $\overline{\text{TO}}$ ,  $\overline{\text{PD}}$  and GPWUF bits. They are set or cleared differently in different Reset situations. These bits are used in software to determine the nature of Reset. See Table 8-3 for a full description of Reset states of all registers.

**TABLE 8-3: RESET CONDITIONS FOR REGISTERS**

Register	Address	Power-on Reset	$\overline{\text{MCLR}}$ Reset, WDT Time-out, Wake-up On Pin Change
W	—	qqqq qq0 <sup>(1)</sup>	qqqq qq0 <sup>(1)</sup>
INDF	00h	xxxx xxxx	uuuu uuuu
TMR0	01h	xxxx xxxx	uuuu uuuu
PCL	02h	1111 1111	1111 1111
STATUS	03h	0-01 1xxx	q-0q quuu <sup>(2), (3)</sup>
FSR	04h	110x xxxx	11uu uuuu
OSCCAL	05h	1111 111-	uuuu uu-
PORTB	06h	--xx xxxx	--uu uuuu
OPTION	—	1111 1111	1111 1111
TRIS	—	--11 1111	--11 1111
EECON	21h	---0 x000	---0 q000
EEDATA	25h	xxxx xxxx	uuuu uuuu
EEADR	26h	--xx xxxx	--uu uuuu

**Legend:** u = unchanged, x = unknown, - = unimplemented bit, read as ‘0’, q = value depends on condition.

**Note 1:** Bits <7:1> of W register contain oscillator calibration values due to `MOVLW XX` instruction at top of memory.

**2:** See Table 8-4 for Reset value for specific conditions.

**3:** If Reset was due to wake-up on pin change, then bit 7 = 1. All other Resets will cause bit 7 = 0.

# PIC12F519

**TABLE 8-4: RESET CONDITION FOR SPECIAL REGISTERS**

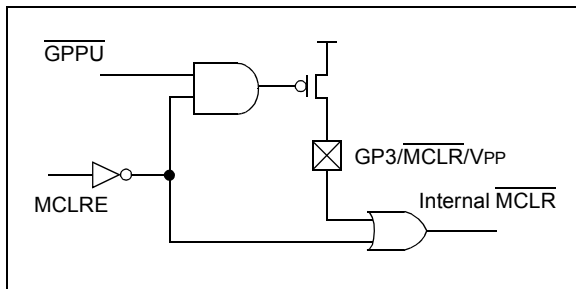
	STATUS Addr: 03h
Power-on Reset	0-01 1xxx
MCLR Reset during normal operation	0-0u uuuu
MCLR Reset during Sleep	0-01 0uuu
WDT Reset during Sleep	0-00 0uuu
WDT Reset normal operation	0-00 uuuu
Wake-up from Sleep on pin change	1-01 0uuu

**Legend:** u = unchanged, x = unknown

## 8.3.1 MCLR ENABLE

This Configuration bit, when unprogrammed (left in the '1' state), enables the external MCLR function. When programmed, the MCLR function is tied to the internal VDD and the pin is assigned to be a I/O. See Figure 8-6.

**FIGURE 8-6: MCLR SELECT**



## 8.4 Power-on Reset (POR)

The PIC12F519 device incorporates an on-chip Power-on Reset (POR) circuitry, which provides an internal chip Reset for most power-up situations.

The on-chip POR circuit holds the chip in Reset until VDD has reached a high enough level for proper operation. To take advantage of the internal POR, program the GP3/MCLR/VPP pin as MCLR and tie through a resistor to VDD, or program the pin as GP3, in which case, an internal weak pull-up resistor is implemented using a transistor (refer to Table 11-4 for the pull-up resistor ranges). This will eliminate external RC components usually needed to create a Power-on Reset. A maximum rise time for VDD is specified. See **Section 11.0 “Electrical Characteristics”** for details.

When the devices start normal operation (exit the Reset condition), device operating parameters (voltage, frequency, temperature,...) must be met to ensure operation. If these conditions are not met, the devices must be held in Reset until the operating parameters are met.

A simplified block diagram of the on-chip Power-on Reset circuit is shown in Figure 8-7.

The Power-on Reset circuit and the Device Reset Timer (see **Section 8.5 “Device Reset Timer (DRT)”**) circuit are closely related. On power-up, the Reset latch is set and the DRT is reset. The DRT timer begins counting once it detects MCLR to be high. After the time-out period, which is typically 18 ms or 1 ms, it will reset the Reset latch and thus end the on-chip Reset signal.

A power-up example where MCLR is held low is shown in Figure 8-8. VDD is allowed to rise and stabilize before bringing MCLR high. The chip will actually come out of Reset TDRT after MCLR goes high.

In Figure 8-9, the on-chip Power-on Reset feature is being used (MCLR and VDD are tied together or the pin is programmed to be GP3). The VDD is stable before the Start-up timer times out and there is no problem in getting a proper Reset. However, Figure 8-10 depicts a problem situation where VDD rises too slowly. The time between when the DRT senses that MCLR is high and when MCLR and VDD actually reach their full value, is too long. In this situation, when the start-up timer times out, VDD has not reached the VDD (min) value and the chip may not function correctly. For such situations, we recommend that external RC circuits be used to achieve longer POR delay times (Figure 8-9).

**Note:** When the devices start normal operation (exit the Reset condition), device operating parameters (voltage, frequency, temperature, etc.) must be met to ensure operation. If these conditions are not met, the device must be held in Reset until the operating conditions are met.

For additional information, refer to Application Note AN522, “Power-Up Considerations” (DS00522)

FIGURE 8-7: SIMPLIFIED BLOCK DIAGRAM OF ON-CHIP RESET CIRCUIT

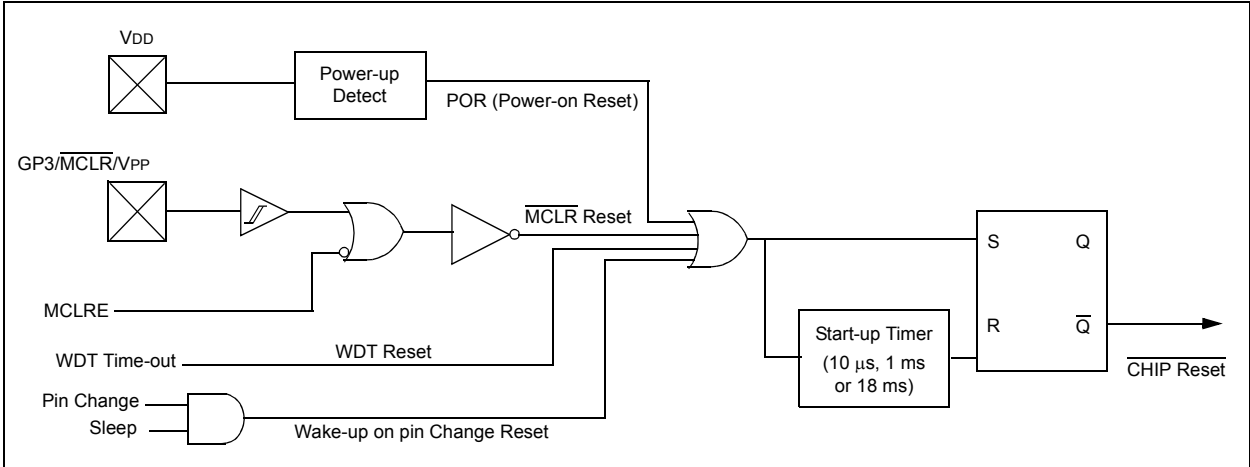


FIGURE 8-8: TIME-OUT SEQUENCE ON POWER-UP ( $\overline{\text{MCLR}}$  PULLED LOW)

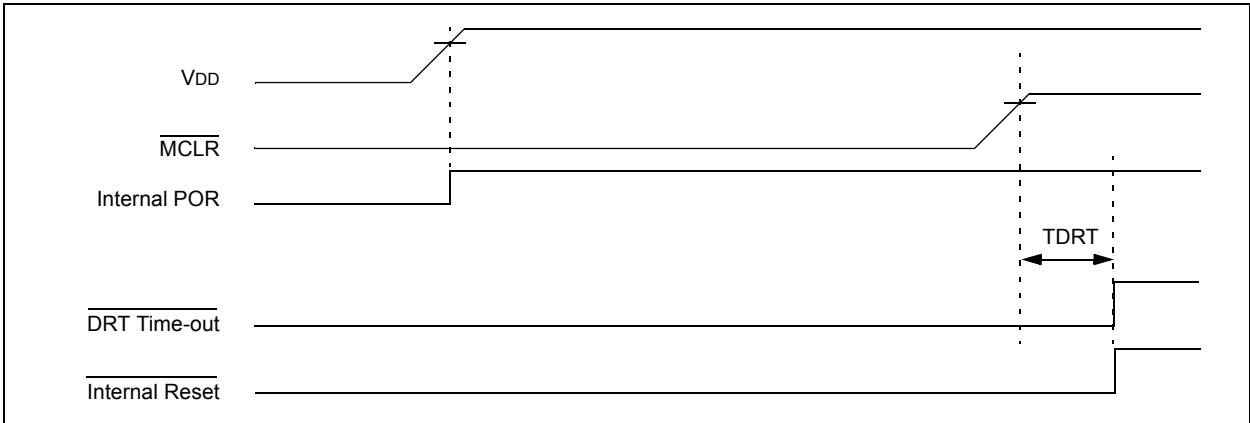
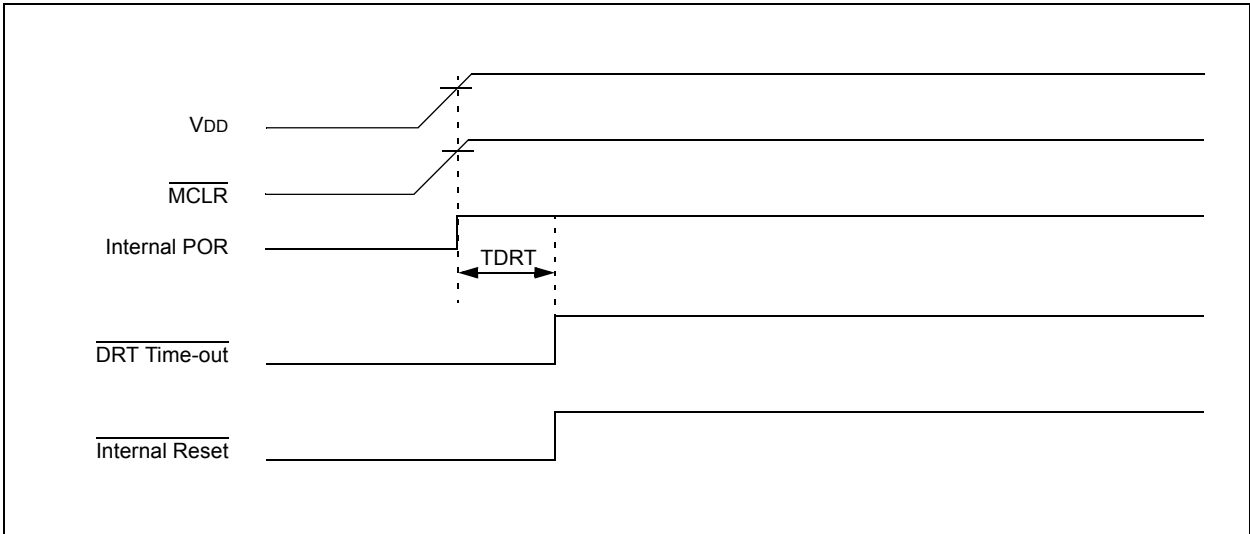
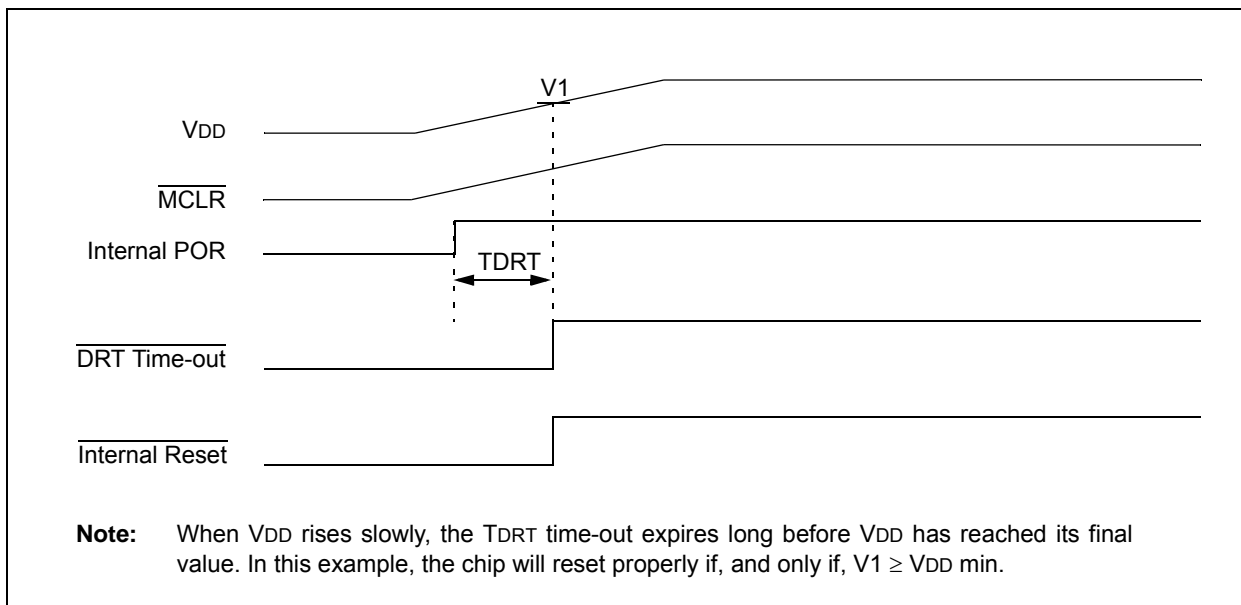


FIGURE 8-9: TIME-OUT SEQUENCE ON POWER-UP ( $\overline{\text{MCLR}}$  TIED TO  $V_{DD}$ ): FAST  $V_{DD}$  RISE TIME



# PIC12F519

FIGURE 8-10: TIME-OUT SEQUENCE ON POWER-UP ( $\overline{\text{MCLR}}$  TIED TO  $V_{\text{DD}}$ ): SLOW  $V_{\text{DD}}$  RISE TIME



## 8.5 Device Reset Timer (DRT)

On the PIC12F519 device, the DRT runs any time the device is powered up. DRT runs from Reset and varies based on oscillator selection and Reset type (see Table 8-5).

The DRT operates on an internal RC oscillator. The processor is kept in Reset as long as the DRT is active. The DRT delay allows VDD to rise above VDD min. and for the oscillator to stabilize.

Oscillator circuits based on crystals or ceramic resonators require a certain time after power-up to establish a stable oscillation. The on-chip DRT keeps the devices in a Reset condition after  $\overline{MCLR}$  has reached a logic high ( $V_{IH}$  MCLR) level. Programming GP3/MCLR/VPP as MCLR and using an external RC network connected to the MCLR input is not required in most cases. This allows savings in cost-sensitive and/or space restricted applications, as well as allowing the use of the GP3/MCLR/VPP pin as a general purpose input.

The Device Reset Time delays will vary from chip-to-chip due to VDD, temperature and process variation. See AC parameters for details.

The DRT will also be triggered upon a Watchdog Timer time-out from Sleep. This is particularly important for applications using the WDT to wake from Sleep mode automatically.

Reset sources are POR,  $\overline{MCLR}$ , WDT time-out and wake-up on pin change. See Section 8.8.2 "Wake-up from Sleep", Notes 1, 2 and 3.

**TABLE 8-5: DRT (DEVICE RESET TIMER PERIOD)**

Oscillator Configuration	POR Reset	Subsequent Resets
INTOSC, EXTRC	1 ms (typical)	10 $\mu$ s (typical)
LP, XT	18 ms (typical)	18 ms (typical)

## 8.6 Watchdog Timer (WDT)

The Watchdog Timer (WDT) is a free running on-chip RC oscillator, which does not require any external components. This RC oscillator is separate from the external RC oscillator of the (GP5)/OSC1/CLKIN pin and the internal 4 or 8 MHz oscillator. This means that the WDT will run even if the main processor clock has been stopped, for example, by execution of a SLEEP instruction. During normal operation or Sleep, a WDT Reset or wake-up Reset, generates a device Reset.

The TO bit (STATUS<4>) will be cleared upon a Watchdog Timer Reset.

The WDT can be permanently disabled by programming the configuration WDTE as a '0' (see Section 8.1 "Configuration Bits"). Refer to the PIC12F519 Programming Specification (DS41316) to determine how to access the Configuration Word.

### 8.6.1 WDT PERIOD

The WDT has a nominal time-out period of 18 ms, (with no prescaler). If a longer time-out period is desired, a prescaler with a division ratio of up to 1:128 can be assigned to the WDT (under software control) by writing to the OPTION register. Thus, a time-out period of a nominal 2.3 seconds can be realized. These periods vary with temperature, VDD and part-to-part process variations (see DC specs).

Under worst-case conditions (VDD = Min., Temperature = Max., max. WDT prescaler), it may take several seconds before a WDT time-out occurs.

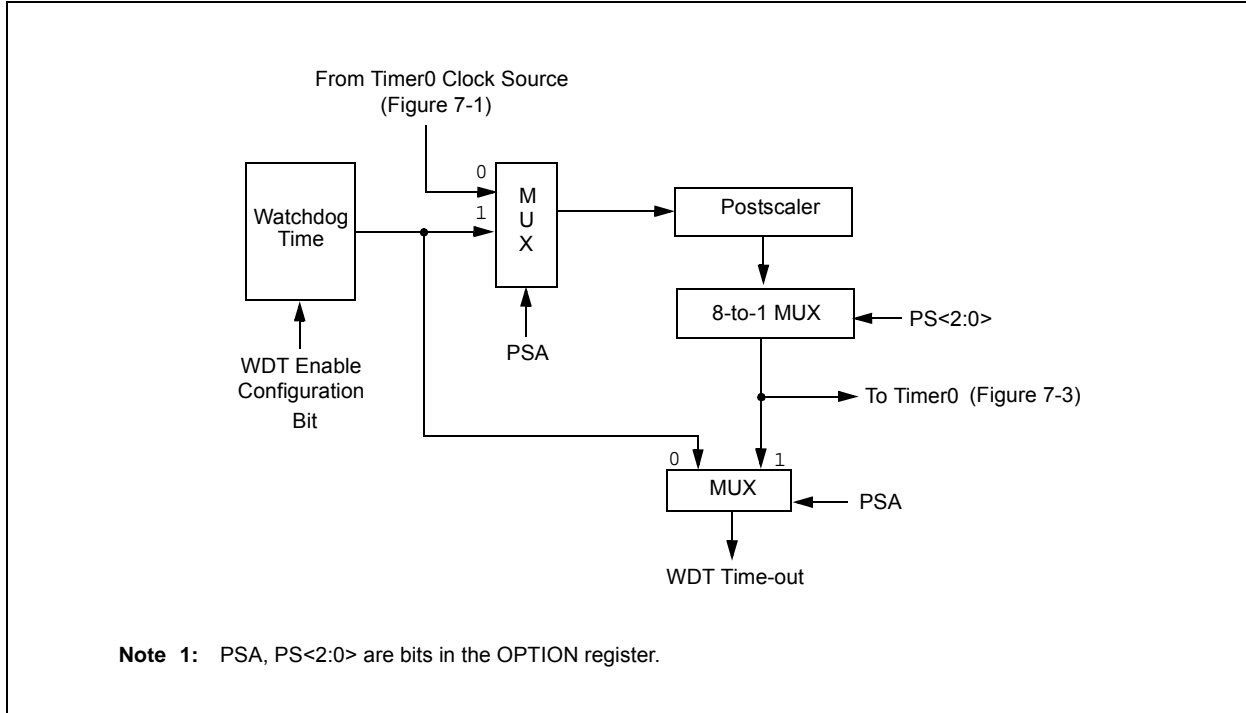
### 8.6.2 WDT PROGRAMMING CONSIDERATIONS

The CLRWDT instruction clears the WDT and the postscaler, if assigned to the WDT, and prevents it from timing out and generating a device Reset.

The SLEEP instruction resets the WDT and the postscaler, if assigned to the WDT. This gives the maximum Sleep time before a WDT wake-up Reset.

# PIC12F519

**FIGURE 8-11: WATCHDOG TIMER BLOCK DIAGRAM**



**TABLE 8-6: SUMMARY OF REGISTER ASSOCIATED WITH THE WATCHDOG TIMER**

Name	Bit 7	Bit 6	Bit 5	Bit 4	Bit 3	Bit 2	Bit 1	Bit 0	Value on POR, BOR	Value on all other Resets
OPTION	GPWU	GPPU	T0CS	T0SE	PSA	PS2	PS1	PS0	1111 1111	1111 1111

**Legend:** Shaded boxes = Not used by Watchdog Timer.



## 8.7 Time-out Sequence, Power-down and Wake-up from Sleep Status Bits ( $\overline{TO}$ , $\overline{PD}$ , GPWUF)

The  $\overline{TO}$ ,  $\overline{PD}$  and (GPWUF) bits in the STATUS register can be tested to determine if a Reset condition has been caused by a power-up condition, a  $\overline{MCLR}$  or Watchdog Timer (WDT) Reset.

**TABLE 8-7:  $\overline{TO}/\overline{PD}/(GPWUF)$  STATUS AFTER RESET**

GPWUF	$\overline{TO}$	$\overline{PD}$	Reset Caused By
0	0	0	WDT wake-up from Sleep
0	0	u	WDT time-out (not from Sleep)
0	1	0	$\overline{MCLR}$ wake-up from Sleep
0	1	1	Power-up
0	u	u	$\overline{MCLR}$ not during Sleep
1	1	0	Wake-up from Sleep on pin change

**Legend:** u = unchanged

**Note 1:** The  $\overline{TO}$ ,  $\overline{PD}$  and GPWUF bits maintain their status (u) until a Reset occurs. A low-pulse on the  $\overline{MCLR}$  input does not change the  $\overline{TO}$ ,  $\overline{PD}$  and GPWUF Status bits.

## 8.8 Power-down Mode (Sleep)

A device may be powered down (Sleep) and later powered up (wake-up from Sleep).

### 8.8.1 SLEEP

The Power-down mode is entered by executing a SLEEP instruction.

If enabled, the Watchdog Timer will be cleared but keeps running, the  $\overline{TO}$  bit (STATUS<4>) is set, the  $\overline{PD}$  bit (STATUS<3>) is cleared and the oscillator driver is turned off. The I/O ports maintain the status they had before the SLEEP instruction was executed (driving high, driving low or high-impedance).

**Note:** A Reset generated by a WDT time-out does not drive the  $\overline{MCLR}$  pin low.

For lowest current consumption while powered down, the T0CKI input should be at VDD or VSS and the GP3/ $\overline{MCLR}/VPP$  pin must be at a logic high level if  $\overline{MCLR}$  is enabled.

### 8.8.2 WAKE-UP FROM SLEEP

The device can wake-up from Sleep through one of the following events:

5. An external Reset input on GP3/ $\overline{MCLR}/VPP$  pin, when configured as  $\overline{MCLR}$ .
6. A Watchdog Timer Time-out Reset (if WDT was enabled).
7. A change on input pin GP0, GP1 and GP3 when wake-up on change is enabled.

These events cause a device Reset. The  $\overline{TO}$ ,  $\overline{PD}$  and GPWUF bits can be used to determine the cause of device Reset. The  $\overline{TO}$  bit is cleared if a WDT time-out occurred (and caused wake-up). The  $\overline{PD}$  bit, which is set on power-up, is cleared when SLEEP is invoked. The GPWUF bit indicates a change in state while in Sleep at pins GP0, GP1 and GP3 (since the last file or bit operation on GPIO port).

**Note:** **Caution:** Right before entering Sleep, read the input pins. When in Sleep, wake up occurs when the values at the pins change from the state they were in at the last reading. If a wake-up on change occurs and the pins are not read before re-entering Sleep, a wake-up will occur immediately even if no pins change while in Sleep mode.

The WDT is cleared when the device wakes from Sleep, regardless of the wake-up source.

# PIC12F519

## 8.9 Program Verification/Code Protection

If the code protection bits have not been programmed, the on-chip program and data memory can be read out for verification purposes.

The first 64 locations and the last location (OSCCAL) can be read, regardless of the setting of the program memory's code protection bit. If the code protect bit specific to the FLASH data memory is programmed, then none of the contents of this memory region can be verified externally.

## 8.10 ID Locations

Four memory locations are designated as ID locations where users can store checksum or other code identification numbers. These locations are not accessible during normal execution, but are readable and writable during program/verify.

Use only the lower 4 bits of the ID locations. The upper bits should be programmed as 0s.

## 8.11 In-Circuit Serial Programming™

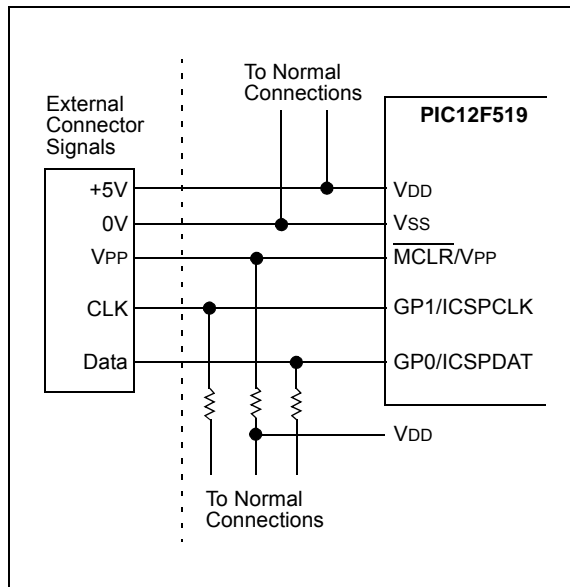
The PIC12F519 device can be serially programmed while in the end application circuit. This is simply done with two lines for clock and data, and three other lines for power, ground and the programming voltage. This allows users to manufacture boards with unprogrammed PIC12F519 device and then program the PIC12F519 device just before shipping the product. This also allows the most recent firmware, or a custom firmware, to be programmed.

The PIC12F519 device is placed into a Program/Verify mode by holding the GP1 and GP0 pins low while raising the MCLR (VPP) pin from  $V_{IL}$  to  $V_{IH}$  (see programming specification). The GP1 pin becomes the programming clock, and the GP0 pin becomes the programming data. Both GP1 and GP0 pins are Schmitt Trigger inputs in this mode.

After Reset, a 6-bit command is then supplied to the device. Depending on the command, 14 bits of program data are then supplied to or from the device, depending if the command was a Load or a Read. For complete details of serial programming, please refer to the "PIC12F519 Memory Programming Specification," (DS41316).

A typical In-Circuit Serial Programming connection is shown in Figure 8-12.

FIGURE 8-12: TYPICAL IN-CIRCUIT SERIAL PROGRAMMING CONNECTION



## 9.0 INSTRUCTION SET SUMMARY

The PIC12F519 instruction set is highly orthogonal and is comprised of three basic categories.

- **Byte-oriented** operations
- **Bit-oriented** operations
- **Literal and control** operations

Each PIC12F519 instruction is a 12-bit word divided into an **opcode**, which specifies the instruction type, and one or more **operands** which further specify the operation of the instruction. The formats for each of the categories is presented in Figure 9-1, while the various opcode fields are summarized in Table 9-1.

For **byte-oriented** instructions, 'f' represents a file register designator and 'd' represents a destination designator. The file register designator specifies which file register is to be used by the instruction.

The destination designator specifies where the result of the operation is to be placed. If 'd' is '0', the result is placed in the W register. If 'd' is '1', the result is placed in the file register specified in the instruction.

For **bit-oriented** instructions, 'b' represents a bit field designator which selects the number of the bit affected by the operation, while 'f' represents the number of the file in which the bit is located.

For **literal and control** operations, 'k' represents an 8 or 9-bit constant or literal value.

**TABLE 9-1: OPCODE FIELD DESCRIPTIONS**

Field	Description
f	Register file address (0x00 to 0x7F)
W	Working register (accumulator)
b	Bit address within an 8-bit file register
k	Literal field, constant data or label
x	Don't care location (= 0 or 1) The assembler will generate code with x = 0. It is the recommended form of use for compatibility with all Microchip software tools.
d	Destination select; d = 0 (store result in W) d = 1 (store result in file register 'f') Default is d = 1
label	Label name
TOS	Top-of-Stack
PC	Program Counter
WDT	Watchdog Timer counter
$\overline{TO}$	Time-out bit
$\overline{PD}$	Power-down bit
dest	Destination, either the W register or the specified register file location
[ ]	Options
( )	Contents
→	Assigned to
< >	Register bit field
∈	In the set of
<i>italics</i>	User defined term (font is courier)

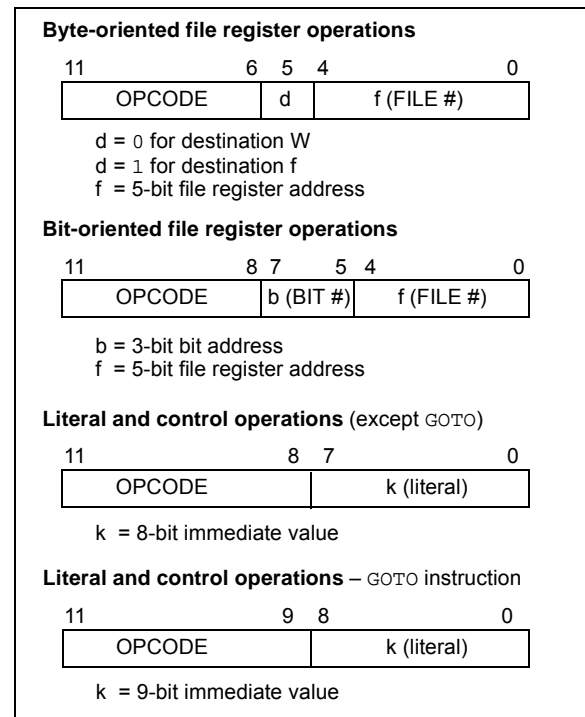
All instructions are executed within a single instruction cycle, unless a conditional test is true or the program counter is changed as a result of an instruction. In this case, the execution takes two instruction cycles. One instruction cycle consists of four oscillator periods. Thus, for an oscillator frequency of 4 MHz, the normal instruction execution time is 1  $\mu$ s. If a conditional test is true or the program counter is changed as a result of an instruction, the instruction execution time is 2  $\mu$ s.

Figure 9-1 shows the three general formats that the instructions can have. All examples in the figure use the following format to represent a hexadecimal number:

0xhhh

where 'h' signifies a hexadecimal digit.

**FIGURE 9-1: GENERAL FORMAT FOR INSTRUCTIONS**



# PIC12F519

**TABLE 9-2: INSTRUCTION SET SUMMARY**

Mnemonic, Operands	Description	Cycles	12-Bit Opcode			Status Affected	Notes
			MSb	LSb			
ADDWF f, d	Add W and f	1	0001	11df	ffff	C, DC, Z	1, 2, 4
ANDWF f, d	AND W with f	1	0001	01df	ffff	Z	2, 4
CLRF f	Clear f	1	0000	011f	ffff	Z	4
CLRW –	Clear W	1	0000	0100	0000	Z	
COMF f, d	Complement f	1	0010	01df	ffff	Z	
DECF f, d	Decrement f	1	0000	11df	ffff	Z	2, 4
DECFSZ f, d	Decrement f, Skip if 0	1(2)	0010	11df	ffff	None	2, 4
INCF f, d	Increment f	1	0010	10df	ffff	Z	2, 4
INCFSZ f, d	Increment f, Skip if 0	1(2)	0011	11df	ffff	None	2, 4
IORWF f, d	Inclusive OR W with f	1	0001	00df	ffff	Z	2, 4
MOVF f, d	Move f	1	0010	00df	ffff	Z	2, 4
MOVWF f	Move W to f	1	0000	001f	ffff	None	1, 4
NOP –	No Operation	1	0000	0000	0000	None	
RLF f, d	Rotate left f through Carry	1	0011	01df	ffff	C	2, 4
RRF f, d	Rotate right f through Carry	1	0011	00df	ffff	C	2, 4
SUBWF f, d	Subtract W from f	1	0000	10df	ffff	C, DC, Z	1, 2, 4
SWAPF f, d	Swap f	1	0011	10df	ffff	None	2, 4
XORWF f, d	Exclusive OR W with f	1	0001	10df	ffff	Z	2, 4
<b>BIT-ORIENTED FILE REGISTER OPERATIONS</b>							
BCF f, b	Bit Clear f	1	0100	bbbdf	ffff	None	2, 4
BSF f, b	Bit Set f	1	0101	bbbdf	ffff	None	2, 4
BTFSC f, b	Bit Test f, Skip if Clear	1(2)	0110	bbbdf	ffff	None	
BTFSS f, b	Bit Test f, Skip if Set	1(2)	0111	bbbdf	ffff	None	
<b>LITERAL AND CONTROL OPERATIONS</b>							
ANDLW k	AND literal with W	1	1110	kkkk	kkkk	Z	
CALL k	Call Subroutine	2	1001	kkkk	kkkk	None	1
CLRWDT –	Clear Watchdog Timer	1	0000	0000	0100	TO, PD	
GOTO k	Unconditional branch	2	101k	kkkk	kkkk	None	
IORLW k	Inclusive OR literal with W	1	1101	kkkk	kkkk	Z	
MOVLW k	Move literal to W	1	1100	kkkk	kkkk	None	
OPTION –	Load OPTION register	1	0000	0000	0010	None	
RETLW k	Return, place literal in W	2	1000	kkkk	kkkk	None	
SLEEP –	Go into Standby mode	1	0000	0000	0011	TO, PD	
TRISGPIO f	Load TRISGPIO register	1	0000	0000	0fff	None	3
XORLW k	Exclusive OR literal to W	1	1111	kkkk	kkkk	Z	

**Note 1:** The 9th bit of the program counter will be forced to a '0' by any instruction that writes to the PC except for GOTO. See Section 4.6 "Program Counter".

- 2: When an I/O register is modified as a function of itself (e.g. MOVF GPIO, 1), the value used will be that value present on the pins themselves. For example, if the data latch is '1' for a pin configured as input and is driven low by an external device, the data will be written back with a '0'.
- 3: The instruction TRIS f, where f = 6, causes the contents of the W register to be written to the tri-state latches of GPIO. A '1' forces the pin to a high-impedance state and disables the output buffers.
- 4: If this instruction is executed on the TMR0 register (and, where applicable, d = 1), the prescaler will be cleared (if assigned to TMR0).

---

## **ADDWF**      **Add W and f**

---

Syntax:      [ *label* ] ADDWF    f,d  
 Operands:     $0 \leq f \leq 31$   
                $d \in [0,1]$   
 Operation:    (W) + (f) → (dest)  
 Status Affected: C, DC, Z  
 Description:    Add the contents of the W register and register 'f'. If 'd' is '0', the result is stored in the W register. If 'd' is '1', the result is stored back in register 'f'.

---

## **BCF**            **Bit Clear f**

---

Syntax:      [ *label* ] BCF    f,b  
 Operands:     $0 \leq f \leq 31$   
                $0 \leq b \leq 7$   
 Operation:     $0 \rightarrow (f<b>)$   
 Status Affected: None  
 Description:    Bit 'b' in register 'f' is cleared.

---

## **ANDLW**        **AND literal with W**

---

Syntax:      [ *label* ] ANDLW    k  
 Operands:     $0 \leq k \leq 255$   
 Operation:    (W).AND. (k) → (W)  
 Status Affected: Z  
 Description:    The contents of the W register are AND'ed with the eight-bit literal 'k'. The result is placed in the W register.

---

## **BSF**            **Bit Set f**

---

Syntax:      [ *label* ] BSF    f,b  
 Operands:     $0 \leq f \leq 31$   
                $0 \leq b \leq 7$   
 Operation:     $1 \rightarrow (f<b>)$   
 Status Affected: None  
 Description:    Bit 'b' in register 'f' is set.

---

## **ANDWF**        **AND W with f**

---

Syntax:      [ *label* ] ANDWF    f,d  
 Operands:     $0 \leq f \leq 31$   
                $d \in [0,1]$   
 Operation:    (W) .AND. (f) → (dest)  
 Status Affected: Z  
 Description:    The contents of the W register are AND'ed with register 'f'. If 'd' is '0', the result is stored in the W register. If 'd' is '1', the result is stored back in register 'f'.

---

## **BTFSC**        **Bit Test f, Skip if Clear**

---

Syntax:      [ *label* ] BTFSC    f,b  
 Operands:     $0 \leq f \leq 31$   
                $0 \leq b \leq 7$   
 Operation:    skip if (f<b>) = 0  
 Status Affected: None  
 Description:    If bit 'b' in register 'f' is '0', then the next instruction is skipped.  
                   If bit 'b' is '0', then the next instruction fetched during the current instruction execution is discarded, and a NOP is executed instead, making this a two-cycle instruction.

# PIC12F519

---

<b>BTFS</b>	<b>Bit Test f, Skip if Set</b>
Syntax:	[ <i>label</i> ] BTFS f,b
Operands:	$0 \leq f \leq 31$ $0 \leq b < 7$
Operation:	skip if (f<b>) = 1
Status Affected:	None
Description:	If bit 'b' in register 'f' is '1', then the next instruction is skipped. If bit 'b' is '1', then the next instruction fetched during the current instruction execution, is discarded and a NOP is executed instead, making this a two-cycle instruction.

<b>CALL</b>	<b>Subroutine Call</b>
Syntax:	[ <i>label</i> ] CALL k
Operands:	$0 \leq k \leq 255$
Operation:	(PC) + 1 → Top-of-Stack; k → PC<7:0>; (STATUS<6:5>) → PC<10:9>; 0 → PC<8>
Status Affected:	None
Description:	Subroutine call. First, return address (PC + 1) is pushed onto the stack. The eight-bit immediate address is loaded into PC bits <7:0>. The upper bits PC<10:9> are loaded from STATUS<6:5>, PC<8> is cleared. CALL is a two-cycle instruction.

<b>CLRF</b>	<b>Clear f</b>
Syntax:	[ <i>label</i> ] CLRF f
Operands:	$0 \leq f \leq 31$
Operation:	00h → (f); 1 → Z
Status Affected:	Z
Description:	The contents of register 'f' are cleared and the Z bit is set.

<b>CLRW</b>	<b>Clear W</b>
Syntax:	[ <i>label</i> ] CLRW
Operands:	None
Operation:	00h → (W); 1 → Z
Status Affected:	Z
Description:	The W register is cleared. Zero bit (Z) is set.

<b>CLRWD</b>	<b>Clear Watchdog Timer</b>
Syntax:	[ <i>label</i> ] CLRWD
Operands:	None
Operation:	00h → WDT; 0 → WDT prescaler (if assigned); 1 → $\overline{TO}$ ; 1 → $\overline{PD}$
Status Affected:	$\overline{TO}$ , $\overline{PD}$
Description:	The CLRWD instruction resets the WDT. It also resets the prescaler, if the prescaler is assigned to the WDT and not Timer0. Status bits $\overline{TO}$ and $\overline{PD}$ are set.

<b>COMF</b>	<b>Complement f</b>
Syntax:	[ <i>label</i> ] COMF f,d
Operands:	$0 \leq f \leq 31$ d ∈ [0,1]
Operation:	(f) → (dest)
Status Affected:	Z
Description:	The contents of register 'f' are complemented. If 'd' is '0', the result is stored in the W register. If 'd' is '1', the result is stored back in register 'f'.

<b>DECF</b>	<b>Decrement f</b>
Syntax:	[ <i>label</i> ] DECF f,d
Operands:	$0 \leq f \leq 31$ $d \in [0,1]$
Operation:	$(f) - 1 \rightarrow (\text{dest})$
Status Affected:	Z
Description:	Decrement register 'f'. If 'd' is '0', the result is stored in the W register. If 'd' is '1', the result is stored back in register 'f'.

<b>INCF</b>	<b>Increment f</b>
Syntax:	[ <i>label</i> ] INCF f,d
Operands:	$0 \leq f \leq 31$ $d \in [0,1]$
Operation:	$(f) + 1 \rightarrow (\text{dest})$
Status Affected:	Z
Description:	The contents of register 'f' are incremented. If 'd' is '0', the result is placed in the W register. If 'd' is '1', the result is placed back in register 'f'.

<b>DECFSZ</b>	<b>Decrement f, Skip if 0</b>
Syntax:	[ <i>label</i> ] DECFSZ f,d
Operands:	$0 \leq f \leq 31$ $d \in [0,1]$
Operation:	$(f) - 1 \rightarrow d$ ; skip if result = 0
Status Affected:	None
Description:	The contents of register 'f' are decremented. If 'd' is '0', the result is placed in the W register. If 'd' is '1', the result is placed back in register 'f'. If the result is '0', the next instruction, which is already fetched, is discarded and a NOP is executed instead making it a two-cycle instruction.

<b>INCFSZ</b>	<b>Increment f, Skip if 0</b>
Syntax:	[ <i>label</i> ] INCFSZ f,d
Operands:	$0 \leq f \leq 31$ $d \in [0,1]$
Operation:	$(f) + 1 \rightarrow (\text{dest})$ , skip if result = 0
Status Affected:	None
Description:	The contents of register 'f' are incremented. If 'd' is '0', the result is placed in the W register. If 'd' is '1', the result is placed back in register 'f'. If the result is '0', then the next instruction, which is already fetched, is discarded and a NOP is executed instead making it a two-cycle instruction.

<b>GOTO</b>	<b>Unconditional Branch</b>
Syntax:	[ <i>label</i> ] GOTO k
Operands:	$0 \leq k \leq 511$
Operation:	$k \rightarrow \text{PC}<8:0>$ ; $\text{STATUS}<6:5> \rightarrow \text{PC}<10:9>$
Status Affected:	None
Description:	GOTO is an unconditional branch. The 9-bit immediate value is loaded into PC bits <8:0>. The upper bits of PC are loaded from STATUS<6:5>. GOTO is a two-cycle instruction.

<b>IORLW</b>	<b>Inclusive OR literal with W</b>
Syntax:	[ <i>label</i> ] IORLW k
Operands:	$0 \leq k \leq 255$
Operation:	$(W) .\text{OR}. (k) \rightarrow (W)$
Status Affected:	Z
Description:	The contents of the W register are OR'ed with the eight-bit literal 'k'. The result is placed in the W register.

# PIC12F519

---

## **IORWF**      **Inclusive OR W with f**

---

Syntax:      [ *label* ] IORWF f,d  
Operands:     $0 \leq f \leq 31$   
               $d \in [0,1]$   
Operation:    (W).OR. (f) → (dest)  
Status Affected: Z  
Description:    Inclusive OR the W register with register 'f'. If 'd' is '0', the result is placed in the W register. If 'd' is '1', the result is placed back in register 'f'.

## **MOVWF**      **Move W to f**

---

Syntax:      [ *label* ] MOVWF f  
Operands:     $0 \leq f \leq 31$   
Operation:    (W) → (f)  
Status Affected: None  
Description:    Move data from the W register to register 'f'.

## **MOVF**      **Move f**

---

Syntax:      [ *label* ] MOVF f,d  
Operands:     $0 \leq f \leq 31$   
               $d \in [0,1]$   
Operation:    (f) → (dest)  
Status Affected: Z  
Description:    The contents of register 'f' are moved to destination 'd'. If 'd' is '0', destination is the W register. If 'd' is '1', the destination is file register 'f'. 'd' = 1 is useful as a test of a file register, since status flag Z is affected.

## **NOP**      **No Operation**

---

Syntax:      [ *label* ] NOP  
Operands:    None  
Operation:    No operation  
Status Affected: None  
Description:    No operation.

## **MOVLW**      **Move Literal to W**

---

Syntax:      [ *label* ] MOVLW k  
Operands:     $0 \leq k \leq 255$   
Operation:     $k \rightarrow (W)$   
Status Affected: None  
Description:    The eight-bit literal 'k' is loaded into the W register. The "don't cares" will be assembled as '0's.

## **OPTION**      **Load OPTION Register**

---

Syntax:      [ *label* ] OPTION  
Operands:    None  
Operation:    (W) → OPTION  
Status Affected: None  
Description:    The content of the W register is loaded into the OPTION register.



**RETLW**      **Return with Literal in W**

---

Syntax:      [ *label* ] RETLW k

Operands:     $0 \leq k \leq 255$

Operation:     $k \rightarrow (W)$ ;  
TOS  $\rightarrow$  PC

Status Affected: None

Description:    The W register is loaded with the eight-bit literal 'k'. The program counter is loaded from the top of the stack (the return address). This is a two-cycle instruction.

**SLEEP**      **Enter SLEEP Mode**

---

Syntax:      [ *label* ] SLEEP

Operands:    None

Operation:    00h  $\rightarrow$  WDT;  
0  $\rightarrow$  WDT prescaler;  
1  $\rightarrow$   $\overline{TO}$ ;  
0  $\rightarrow$  PD

Status Affected:  $\overline{TO}$ ,  $\overline{PD}$ , GPWUF

Description:    Time-out Status bit ( $\overline{TO}$ ) is set. The Power-down Status bit ( $\overline{PD}$ ) is cleared.  
GPWUF is unaffected.  
The WDT and its prescaler are cleared.  
The processor is put into Sleep mode with the oscillator stopped.  
See **Section 8.8 "Power-down Mode (Sleep)"** on Sleep for more details.

**RLF**          **Rotate Left f through Carry**

---

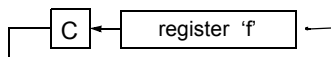
Syntax:      [ *label* ]          RLF f,d

Operands:     $0 \leq f \leq 31$   
 $d \in [0,1]$

Operation:    See description below

Status Affected: C

Description:    The contents of register 'f' are rotated one bit to the left through the Carry flag. If 'd' is '0', the result is placed in the W register. If 'd' is '1', the result is stored back in register 'f'.



**SUBWF**      **Subtract W from f**

---

Syntax:      [ *label* ] SUBWF f,d

Operands:     $0 \leq f \leq 31$   
 $d \in [0,1]$

Operation:     $(f) - (W) \rightarrow (dest)$

Status Affected: C, DC, Z

Description:    Subtract (two's complement method) the W register from register 'f'. If 'd' is '0', the result is stored in the W register. If 'd' is '1', the result is stored back in register 'f'.

**RRF**          **Rotate Right f through Carry**

---

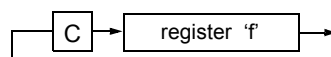
Syntax:      [ *label* ] RRF f,d

Operands:     $0 \leq f \leq 31$   
 $d \in [0,1]$

Operation:    See description below

Status Affected: C

Description:    The contents of register 'f' are rotated one bit to the right through the Carry flag. If 'd' is '0', the result is placed in the W register. If 'd' is '1', the result is placed back in register 'f'.



**SWAPF**      **Swap Nibbles in f**

---

Syntax:      [ *label* ] SWAPF f,d

Operands:     $0 \leq f \leq 31$   
 $d \in [0,1]$

Operation:     $(f<3:0>) \rightarrow (dest<7:4>)$ ;  
 $(f<7:4>) \rightarrow (dest<3:0>)$

Status Affected: None

Description:    The upper and lower nibbles of register 'f' are exchanged. If 'd' is '0', the result is placed in W register. If 'd' is '1', the result is placed in register 'f'.

# PIC12F519

---

## **TRIS**                    **Load TRIS Register**

---

Syntax:            [ *label* ] TRIS    f  
Operands:        f = 6  
Operation:        (W) → TRIS register f  
Status Affected: None  
Description:     TRIS register 'f' (f = 6 or 7) is loaded with the contents of the W register.

## **XORLW**                **Exclusive OR literal with W**

---

Syntax:            [ *label* ] XORLW k  
Operands:        0 ≤ k ≤ 255  
Operation:        (W) .XOR. k → (W)  
Status Affected: Z  
Description:     The contents of the W register are XOR'ed with the eight-bit literal 'k'. The result is placed in the W register.

## **XORWF**                **Exclusive OR W with f**

---

Syntax:            [ *label* ] XORWF   f,d  
Operands:        0 ≤ f ≤ 31  
                      d ∈ [0,1]  
Operation:        (W) .XOR. (f) → (dest)  
Status Affected: Z  
Description:     Exclusive OR the contents of the W register with register 'f'. If 'd' is '0', the result is stored in the W register. If 'd' is '1', the result is stored back in register 'f'.

## 10.0 DEVELOPMENT SUPPORT

The PIC<sup>®</sup> microcontrollers are supported with a full range of hardware and software development tools:

- Integrated Development Environment
  - MPLAB<sup>®</sup> IDE Software
- Assemblers/Compilers/Linkers
  - MPASM<sup>™</sup> Assembler
  - MPLAB C18 and MPLAB C30 C Compilers
  - MPLINK<sup>™</sup> Object Linker/  
MPLIB<sup>™</sup> Object Librarian
  - MPLAB ASM30 Assembler/Linker/Library
- Simulators
  - MPLAB SIM Software Simulator
- Emulators
  - MPLAB ICE 2000 In-Circuit Emulator
  - MPLAB REAL ICE<sup>™</sup> In-Circuit Emulator
- In-Circuit Debugger
  - MPLAB ICD 2
- Device Programmers
  - PICSTART<sup>®</sup> Plus Development Programmer
  - MPLAB PM3 Device Programmer
  - PICKit<sup>™</sup> 2 Development Programmer
- Low-Cost Demonstration and Development Boards and Evaluation Kits

## 10.1 MPLAB Integrated Development Environment Software

The MPLAB IDE software brings an ease of software development previously unseen in the 8/16-bit microcontroller market. The MPLAB IDE is a Windows<sup>®</sup> operating system-based application that contains:

- A single graphical interface to all debugging tools
  - Simulator
  - Programmer (sold separately)
  - Emulator (sold separately)
  - In-Circuit Debugger (sold separately)
- A full-featured editor with color-coded context
- A multiple project manager
- Customizable data windows with direct edit of contents
- High-level source code debugging
- Visual device initializer for easy register initialization
- Mouse over variable inspection
- Drag and drop variables from source to watch windows
- Extensive on-line help
- Integration of select third party tools, such as HI-TECH Software C Compilers and IAR C Compilers

The MPLAB IDE allows you to:

- Edit your source files (either assembly or C)
- One touch assemble (or compile) and download to PIC MCU emulator and simulator tools (automatically updates all project information)
- Debug using:
  - Source files (assembly or C)
  - Mixed assembly and C
  - Machine code

MPLAB IDE supports multiple debugging tools in a single development paradigm, from the cost-effective simulators, through low-cost in-circuit debuggers, to full-featured emulators. This eliminates the learning curve when upgrading to tools with increased flexibility and power.

# PIC12F519

---

## 10.2 MPASM Assembler

The MPASM Assembler is a full-featured, universal macro assembler for all PIC MCUs.

The MPASM Assembler generates relocatable object files for the MPLINK Object Linker, Intel® standard HEX files, MAP files to detail memory usage and symbol reference, absolute LST files that contain source lines and generated machine code and COFF files for debugging.

The MPASM Assembler features include:

- Integration into MPLAB IDE projects
- User-defined macros to streamline assembly code
- Conditional assembly for multi-purpose source files
- Directives that allow complete control over the assembly process

## 10.3 MPLAB C18 and MPLAB C30 C Compilers

The MPLAB C18 and MPLAB C30 Code Development Systems are complete ANSI C compilers for Microchip's PIC18 and PIC24 families of microcontrollers and the dsPIC30 and dsPIC33 family of digital signal controllers. These compilers provide powerful integration capabilities, superior code optimization and ease of use not found with other compilers.

For easy source level debugging, the compilers provide symbol information that is optimized to the MPLAB IDE debugger.

## 10.4 MPLINK Object Linker/ MPLIB Object Librarian

The MPLINK Object Linker combines relocatable objects created by the MPASM Assembler and the MPLAB C18 C Compiler. It can link relocatable objects from precompiled libraries, using directives from a linker script.

The MPLIB Object Librarian manages the creation and modification of library files of precompiled code. When a routine from a library is called from a source file, only the modules that contain that routine will be linked in with the application. This allows large libraries to be used efficiently in many different applications.

The object linker/library features include:

- Efficient linking of single libraries instead of many smaller files
- Enhanced code maintainability by grouping related modules together
- Flexible creation of libraries with easy module listing, replacement, deletion and extraction

## 10.5 MPLAB ASM30 Assembler, Linker and Librarian

MPLAB ASM30 Assembler produces relocatable machine code from symbolic assembly language for dsPIC30F devices. MPLAB C30 C Compiler uses the assembler to produce its object file. The assembler generates relocatable object files that can then be archived or linked with other relocatable object files and archives to create an executable file. Notable features of the assembler include:

- Support for the entire dsPIC30F instruction set
- Support for fixed-point and floating-point data
- Command line interface
- Rich directive set
- Flexible macro language
- MPLAB IDE compatibility

## 10.6 MPLAB SIM Software Simulator

The MPLAB SIM Software Simulator allows code development in a PC-hosted environment by simulating the PIC MCUs and dsPIC® DSCs on an instruction level. On any given instruction, the data areas can be examined or modified and stimuli can be applied from a comprehensive stimulus controller. Registers can be logged to files for further run-time analysis. The trace buffer and logic analyzer display extend the power of the simulator to record and track program execution, actions on I/O, most peripherals and internal registers.

The MPLAB SIM Software Simulator fully supports symbolic debugging using the MPLAB C18 and MPLAB C30 C Compilers, and the MPASM and MPLAB ASM30 Assemblers. The software simulator offers the flexibility to develop and debug code outside of the hardware laboratory environment, making it an excellent, economical software development tool.

## 10.7 MPLAB ICE 2000 High-Performance In-Circuit Emulator

The MPLAB ICE 2000 In-Circuit Emulator is intended to provide the product development engineer with a complete microcontroller design tool set for PIC microcontrollers. Software control of the MPLAB ICE 2000 In-Circuit Emulator is advanced by the MPLAB Integrated Development Environment, which allows editing, building, downloading and source debugging from a single environment.

The MPLAB ICE 2000 is a full-featured emulator system with enhanced trace, trigger and data monitoring features. Interchangeable processor modules allow the system to be easily reconfigured for emulation of different processors. The architecture of the MPLAB ICE 2000 In-Circuit Emulator allows expansion to support new PIC microcontrollers.

The MPLAB ICE 2000 In-Circuit Emulator system has been designed as a real-time emulation system with advanced features that are typically found on more expensive development tools. The PC platform and Microsoft® Windows® 32-bit operating system were chosen to best make these features available in a simple, unified application.

## 10.8 MPLAB REAL ICE In-Circuit Emulator System

MPLAB REAL ICE In-Circuit Emulator System is Microchip's next generation high-speed emulator for Microchip Flash DSC® and MCU devices. It debugs and programs PIC® and dsPIC® Flash microcontrollers with the easy-to-use, powerful graphical user interface of the MPLAB Integrated Development Environment (IDE), included with each kit.

The MPLAB REAL ICE probe is connected to the design engineer's PC using a high-speed USB 2.0 interface and is connected to the target with either a connector compatible with the popular MPLAB ICD 2 system (RJ11) or with the new high speed, noise tolerant, low-voltage differential signal (LVDS) interconnection (CAT5).

MPLAB REAL ICE is field upgradeable through future firmware downloads in MPLAB IDE. In upcoming releases of MPLAB IDE, new devices will be supported, and new features will be added, such as software breakpoints and assembly code trace. MPLAB REAL ICE offers significant advantages over competitive emulators including low-cost, full-speed emulation, real-time variable watches, trace analysis, complex breakpoints, a ruggedized probe interface and long (up to three meters) interconnection cables.

## 10.9 MPLAB ICD 2 In-Circuit Debugger

Microchip's In-Circuit Debugger, MPLAB ICD 2, is a powerful, low-cost, run-time development tool, connecting to the host PC via an RS-232 or high-speed USB interface. This tool is based on the Flash PIC MCUs and can be used to develop for these and other PIC MCUs and dsPIC DSCs. The MPLAB ICD 2 utilizes the in-circuit debugging capability built into the Flash devices. This feature, along with Microchip's In-Circuit Serial Programming™ (ICSP™) protocol, offers cost-effective, in-circuit Flash debugging from the graphical user interface of the MPLAB Integrated Development Environment. This enables a designer to develop and debug source code by setting breakpoints, single stepping and watching variables, and CPU status and peripheral registers. Running at full speed enables testing hardware and applications in real time. MPLAB ICD 2 also serves as a development programmer for selected PIC devices.

## 10.10 MPLAB PM3 Device Programmer

The MPLAB PM3 Device Programmer is a universal, CE compliant device programmer with programmable voltage verification at VDDMIN and VDDMAX for maximum reliability. It features a large LCD display (128 x 64) for menus and error messages and a modular, detachable socket assembly to support various package types. The ICSP™ cable assembly is included as a standard item. In Stand-Alone mode, the MPLAB PM3 Device Programmer can read, verify and program PIC devices without a PC connection. It can also set code protection in this mode. The MPLAB PM3 connects to the host PC via an RS-232 or USB cable. The MPLAB PM3 has high-speed communications and optimized algorithms for quick programming of large memory devices and incorporates an SD/MMC card for file storage and secure data applications.

# PIC12F519

---

## 10.11 PICSTART Plus Development Programmer

The PICSTART Plus Development Programmer is an easy-to-use, low-cost, prototype programmer. It connects to the PC via a COM (RS-232) port. MPLAB Integrated Development Environment software makes using the programmer simple and efficient. The PICSTART Plus Development Programmer supports most PIC devices in DIP packages up to 40 pins. Larger pin count devices, such as the PIC16C92X and PIC17C76X, may be supported with an adapter socket. The PICSTART Plus Development Programmer is CE compliant.

## 10.12 PICkit 2 Development Programmer

The PICkit™ 2 Development Programmer is a low-cost programmer and selected Flash device debugger with an easy-to-use interface for programming many of Microchip's baseline, mid-range and PIC18F families of Flash memory microcontrollers. The PICkit 2 Starter Kit includes a prototyping development board, twelve sequential lessons, software and HI-TECH's PICC™ Lite C compiler, and is designed to help get up to speed quickly using PIC® microcontrollers. The kit provides everything needed to program, evaluate and develop applications using Microchip's powerful, mid-range Flash memory family of microcontrollers.

## 10.13 Demonstration, Development and Evaluation Boards

A wide variety of demonstration, development and evaluation boards for various PIC MCUs and dsPIC DSCs allows quick application development on fully functional systems. Most boards include prototyping areas for adding custom circuitry and provide application firmware and source code for examination and modification.

The boards support a variety of features, including LEDs, temperature sensors, switches, speakers, RS-232 interfaces, LCD displays, potentiometers and additional EEPROM memory.

The demonstration and development boards can be used in teaching environments, for prototyping custom circuits and for learning about various microcontroller applications.

In addition to the PICDEM™ and dsPICDEM™ demonstration/development board series of circuits, Microchip has a line of evaluation kits and demonstration software for analog filter design, KEELOQ® security ICs, CAN, IrDA®, PowerSmart battery management, SEEVAL® evaluation system, Sigma-Delta ADC, flow rate sensing, plus many more.

Check the Microchip web page ([www.microchip.com](http://www.microchip.com)) and the latest "Product Selector Guide" (DS00148) for the complete list of demonstration, development and evaluation kits.

## 11.0 ELECTRICAL CHARACTERISTICS

### Absolute Maximum Ratings<sup>(†)</sup>

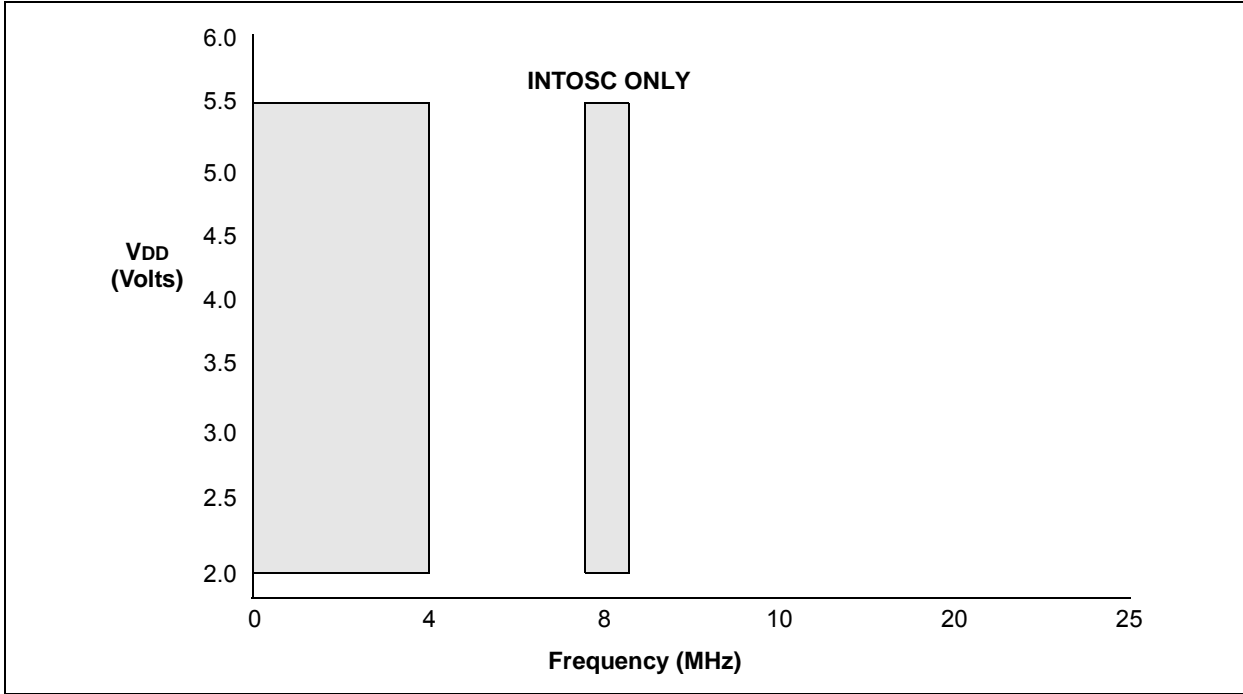
Ambient temperature under bias .....	-40°C to +125°C
Storage temperature .....	-65°C to +150°C
Voltage on V <sub>DD</sub> with respect to V <sub>SS</sub> .....	0 to +6.5V
Voltage on $\overline{\text{MCLR}}$ with respect to V <sub>SS</sub> .....	0 to +13.5V
Voltage on all other pins with respect to V <sub>SS</sub> .....	-0.3V to (V <sub>DD</sub> + 0.3V)
Total power dissipation <sup>(1)</sup> .....	700 mW
Max. current out of V <sub>SS</sub> pin .....	200 mA
Max. current into V <sub>DD</sub> pin .....	150 mA
Input clamp current, I <sub>IK</sub> (V <sub>I</sub> < 0 or V <sub>I</sub> > V <sub>DD</sub> ) .....	±20 mA
Output clamp current, I <sub>OK</sub> (V <sub>O</sub> < 0 or V <sub>O</sub> > V <sub>DD</sub> ) .....	±20 mA
Max. output current sunk by any I/O pin .....	25 mA
Max. output current sourced by any I/O pin .....	25 mA
Max. output current sourced by I/O port .....	75 mA
Max. output current sunk by I/O port .....	75 mA

**Note 1:** Power dissipation is calculated as follows:  $P_{DIS} = V_{DD} \times \{I_{DD} - \sum I_{OH}\} + \sum \{(V_{DD} - V_{OH}) \times I_{OH}\} + \sum (V_{OL} \times I_{OL})$

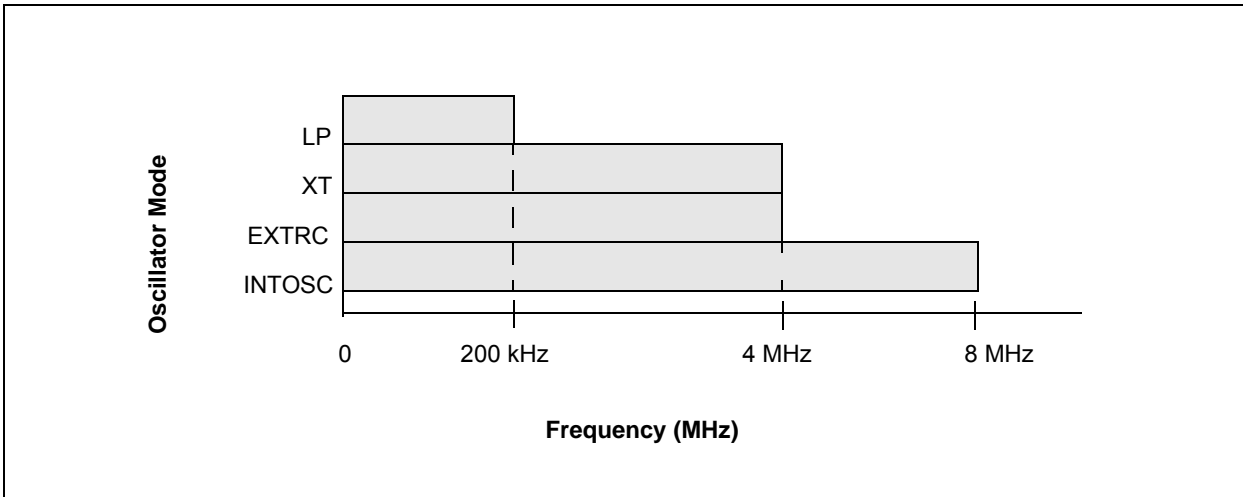
<sup>†</sup>NOTICE: Stresses above those listed under “Absolute Maximum Ratings” may cause permanent damage to the device. This is a stress rating only and functional operation of the device at those or any other conditions above those indicated in the operation listings of this specification is not implied. Exposure to maximum rating conditions for extended periods may affect device reliability.

# PIC12F519

**FIGURE 11-1: PIC12F519 VOLTAGE-FREQUENCY GRAPH,  $-40^{\circ}\text{C} \leq T_A \leq +125^{\circ}\text{C}$**



**FIGURE 11-2: MAXIMUM OSCILLATOR FREQUENCY TABLE**





## 11.1 DC Characteristics

**TABLE 11-1: DC CHARACTERISTICS: PIC12F519 (INDUSTRIAL)**

DC CHARACTERISTICS			Standard Operating Conditions (unless otherwise specified) Operating Temperature $-40^{\circ}\text{C} \leq T_A \leq +85^{\circ}\text{C}$ (industrial)				
Param No.	Sym.	Characteristic	Min.	Typ <sup>(1)</sup>	Max.	Units	Conditions
D001	VDD	Supply Voltage	2.0		5.5	V	See Figure 11-1
D002	VDR	RAM Data Retention Voltage <sup>(2)</sup>	—	1.5*	—	V	Device in Sleep mode
D003	VPOR	VDD Start Voltage to ensure Power-on Reset	—	VSS	—	V	See Section 8.4 “Power-on Reset (POR)” for details
D004	SVDD	VDD Rise Rate to ensure Power-on Reset	0.05*	—	—	V/ms	See Section 8.4 “Power-on Reset (POR)” for details
D005	IDDP	Supply Current During Prog/Erase.	—	250*	—	μA	
D010	IDD	Supply Current <sup>(3,4)</sup>	—	175	250	μA	FOSC = 4 MHz, VDD = 2.0V
			—	400	700	μA	FOSC = 4 MHz, VDD = 5.0V
			—	250	400	μA	FOSC = 8 MHz, VDD = 2.0V
			—	0.75	1.2	mA	FOSC = 8 MHz, VDD = 5.0V
			—	11	20	μA	FOSC = 32 kHz, VDD = 2.0V
			—	38	54	μA	FOSC = 32 kHz, VDD = 5.0V
D020	IPD	Power-down Current <sup>(5)</sup>	—	0.1	1.2	μA	VDD = 2.0V
			—	0.35	2.2	μA	VDD = 5.0V
D022	IWDT	WDT Current	—	1.0	3.0	μA	VDD = 2.0V
			—	7.0	16.0	μA	VDD = 5.0V

\* These parameters are characterized but not tested.

- Note 1:** Data in the Typical (“Typ”) column is based on characterization results at 25°C. This data is for design guidance only and is not tested.
- 2:** This is the limit to which VDD can be lowered in Sleep mode without losing RAM data.
- 3:** The supply current is mainly a function of the operating voltage and frequency. Other factors such as bus loading, oscillator type, bus rate, internal code execution pattern and temperature also have an impact on the current consumption.
- 4:** The test conditions for all IDD measurements in active operation mode are:  
OSC1 = external square wave, from rail-to-rail for external clock modes; all I/O pins tri-stated, pulled to VSS, TOCKI = VDD, MCLR = VDD; WDT enabled/disabled as specified.
- 5:** For standby current measurements, the conditions are the same as IDD, except that the device is in Sleep mode. If a module current is listed, the current is for that specific module enabled and the device in Sleep.

# PIC12F519

**TABLE 11-2: DC CHARACTERISTICS: PIC12F519 (Extended)**

DC CHARACTERISTICS			Standard Operating Conditions (unless otherwise specified) Operating Temperature $-40^{\circ}\text{C} \leq T_A \leq +125^{\circ}\text{C}$ (extended)				
Param No.	Sym.	Characteristic	Min.	Typ <sup>(1)</sup>	Max.	Units	Conditions
D001	VDD	<b>Supply Voltage</b>	2.0		5.5	V	See <b>Figure 11-1</b>
D002	VDR	<b>RAM Data Retention Voltage<sup>(2)</sup></b>	—	1.5*	—	V	Device in Sleep mode
D003	VPOR	<b>VDD Start Voltage</b> to ensure Power-on Reset	—	VSS	—	V	See <b>Section 8.4 “Power-on Reset (POR)”</b> for details
D004	SVDD	<b>VDD Rise Rate</b> to ensure Power-on Reset	0.05*	—	—	V/ms	See <b>Section 8.4 “Power-on Reset (POR)”</b> for details
D005	IDDP	<b>Supply Current</b> During Prog/Erase.	—	250*	—	$\mu\text{A}$	
D010	IDD	<b>Supply Current<sup>(3,4)</sup></b>	—	175	250	$\mu\text{A}$	FOSC = 4 MHz, VDD = 2.0V
			—	400	700	mA	FOSC = 4 MHz, VDD = 5.0V
			—	250	400	$\mu\text{A}$	FOSC = 8 MHz, VDD = 2.0V
			—	0.75	1.2	mA	FOSC = 8 MHz, VDD = 5.0V
			—	11	24	$\mu\text{A}$	FOSC = 32 kHz, VDD = 2.0V
			—	38	110	$\mu\text{A}$	FOSC = 32 kHz, VDD = 5.0V
D020	IPD	<b>Power-down Current<sup>(5)</sup></b>	—	0.1	9.0	$\mu\text{A}$	VDD = 2.0V
			—	0.35	15.0	$\mu\text{A}$	VDD = 5.0V
D022	IWDT	<b>WDT Current</b>	—	1.0	18	$\mu\text{A}$	VDD = 2.0V
			—	7.0	22	$\mu\text{A}$	VDD = 5.0V

\* These parameters are characterized but not tested.

- Note 1:** Data in the Typical (“Typ”) column is based on characterization results at 25°C. This data is for design guidance only and is not tested.
- 2:** This is the limit to which VDD can be lowered in Sleep mode without losing RAM data.
- 3:** The supply current is mainly a function of the operating voltage and frequency. Other factors such as bus loading, oscillator type, bus rate, internal code execution pattern and temperature also have an impact on the current consumption.
- 4:** The test conditions for all IDD measurements in active operation mode are:  
OSC1 = external square wave, from rail-to-rail for external clock modes; all I/O pins tri-stated, pulled to VSS, T0CKI = VDD, MCLR = VDD; WDT enabled/disabled as specified.
- 5:** For standby current measurements, the conditions are the same as IDD, except that the device is in Sleep mode. If a module current is listed, the current is for that specific module enabled and the device in Sleep.

**TABLE 11-3: DC CHARACTERISTICS: PIC12F519 (Industrial, Extended)**

DC CHARACTERISTICS		Standard Operating Conditions (unless otherwise specified) Operating temperature -40°C ≤ TA ≤ +85°C (industrial) -40°C ≤ TA ≤ +125°C (extended) Operating voltage VDD range as described in DC specification.					
Param No.	Sym.	Characteristic	Min.	Typ†	Max.	Units	Conditions
	VIL	<b>Input Low Voltage</b>					
D030		I/O ports	Vss	—	0.8	V	For all 4.5 ≤ VDD ≤ 5.5V
D030A		with TTL buffer	Vss	—	0.15 VDD	V	Otherwise
D031		with Schmitt Trigger buffer	Vss	—	0.15 VDD	V	
D032		MCLR, T0CKI	Vss	—	0.15 VDD	V	
D033		OSC1 (EXTRC mode)	Vss	—	0.15 VDD	V	<b>(Note 1)</b>
D033A		OSC1 (XT and LP modes)	Vss	—	0.3	V	
	VIH	<b>Input High Voltage</b>					
D040		I/O ports	2.0	—	VDD	V	4.5 ≤ VDD ≤ 5.5V
D040A		with TTL buffer	0.25 VDD + 0.8V	—	VDD	V	Otherwise
D041		with Schmitt Trigger buffer	0.85 VDD	—	VDD	V	For entire VDD range
D042		MCLR, T0CKI	0.85 VDD	—	VDD	V	
D042A		OSC1 (EXTRC mode)	0.85 VDD	—	VDD	V	<b>(Note 1)</b>
D043		OSC1 (XT and LP modes)	1.6	—	VDD	V	
D070	IPUR	<b>I/O PORT weak pull-up current<sup>(5)</sup></b>	50	250	400	μA	VDD = 5V, VPIN = VSS
	IIL	<b>Input Leakage Current<sup>(2), (3)</sup></b>					
D060		I/O ports	—	—	±1	μA	VSS ≤ VPIN ≤ VDD, Pin at high-impedance
D061		GP3/MCLR <sup>(4)</sup>	—	±0.7	±5	μA	VSS ≤ VPIN ≤ VDD
D063		OSC1	—	—	±5	μA	VSS ≤ VPIN ≤ VDD, XT and LP osc configuration
		<b>Output Low Voltage</b>					
D080		I/O ports	—	—	0.6	V	IOL = 8.5 mA, VDD = 4.5V, -40°C to +85°C
D080A			—	—	0.6	V	IOL = 7.0 mA, VDD = 4.5V, -40°C to +125°C
		<b>Output High Voltage</b>					
D090		I/O ports <sup>(3)</sup>	VDD - 0.7	—	—	V	I <sub>OH</sub> = -3.0 mA, VDD = 4.5V, -40°C to +85°C
D090A			VDD - 0.7	—	—	V	I <sub>OH</sub> = -2.5 mA, VDD = 4.5V, -40°C to +125°C
		<b>Capacitive Loading Specs on Output Pins</b>					
D101		All I/O pins	—	—	50	pF	
		<b>Flash Data Memory</b>					
D120	ED	Byte endurance	100K	1M	—	E/W	-40°C ≤ TA ≤ +85°C
D120A	ED	Byte endurance	10K	100K	—	E/W	+85°C ≤ TA ≤ +125°C
D121	VDRW	VDD for read/write	VMIN	—	5.5	V	

- † Data in "Typ" column is at 5V, 25°C unless otherwise stated. These parameters are for design guidance only and are not tested.
- Note 1:** In EXTRC oscillator configuration, the OSC1/CLKIN pin is a Schmitt Trigger input. It is not recommended that the PIC12F519 be driven with external clock in RC mode.
- 2:** The leakage current on the MCLR pin is strongly dependent on the applied voltage level. The specified levels represent normal operating conditions. Higher leakage current may be measured at different input voltages.
- 3:** Negative current is defined as coming out of the pin.
- 4:** This specification applies to GP3/MCLR configured as GP3 with internal pull-up disabled.
- 5:** This specification applies to all weak pull-up devices, including the weak pull-up found on GP3/MCLR. The current value listed will be the same whether or not the pin is configured as GP3 with pull-up enabled or MCLR.

# PIC12F519

TABLE 11-4: PULL-UP RESISTOR RANGES

V <sub>DD</sub> (Volts)	Temperature (°C)	Min.	Typ.	Max.	Units
<b>GP0/GP1</b>					
2.0	-40	73K	105K	186K	Ω
	25	73K	113K	187K	Ω
	85	82K	123K	190K	Ω
	125	86K	132K	190K	Ω
5.5	-40	15K	21K	33K	Ω
	25	15K	22K	34K	Ω
	85	19K	26K	35K	Ω
	125	23K	29K	35K	Ω
<b>GP3</b>					
2.0	-40	63K	81K	96K	Ω
	25	77K	93K	116K	Ω
	85	82K	96K	116K	Ω
	125	86K	100K	119K	Ω
5.5	-40	16K	20K	22K	Ω
	25	16K	21K	23K	Ω
	85	24K	25K	28K	Ω
	125	26K	27K	29K	Ω

## 11.2 Timing Parameter Symbology and Load Conditions – PIC12F519

The timing parameter symbols have been created following one of the following formats:

1. TppS2ppS
2. TppS

<b>T</b>	F Frequency	T Time
----------	-------------	--------

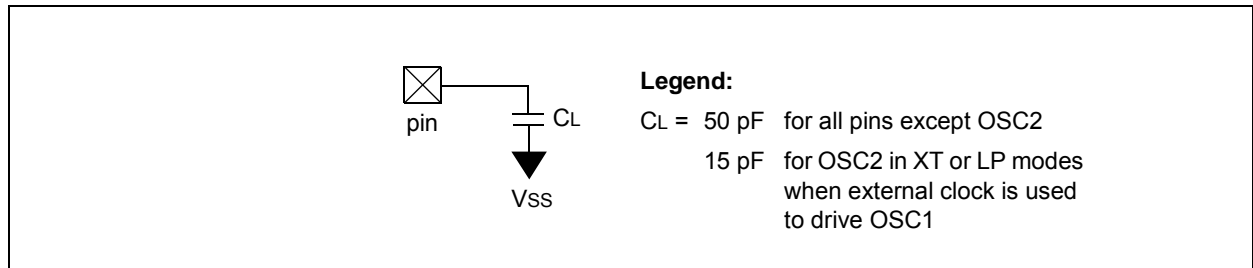
Lowercase subscripts (pp) and their meanings:

<b>pp</b>	2 to	mc	$\overline{\text{MCLR}}$
	ck CLKOUT	osc	Oscillator
	cy Cycle time	os	OSC1
	drt Device Reset Timer	t0	T0CKI
	io I/O port	wdt	Watchdog Timer

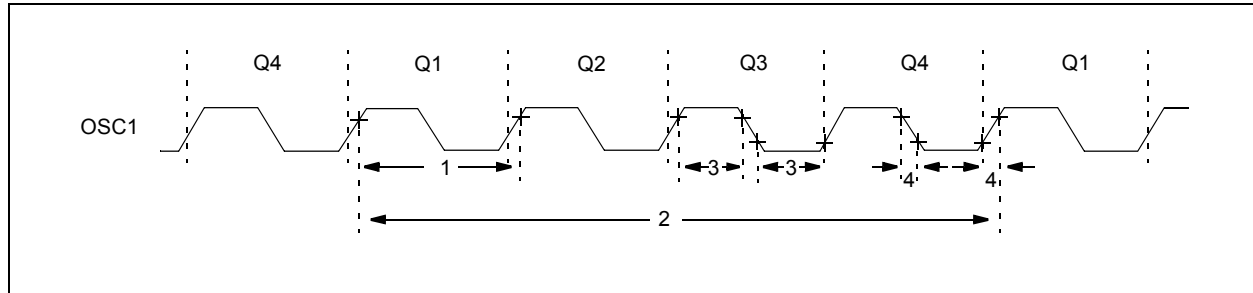
Uppercase letters and their meanings:

<b>S</b>	F Fall	P	Period
	H High	R	Rise
	I Invalid (high-impedance)	V	Valid
	L Low	Z	High-impedance

**FIGURE 11-3: LOAD CONDITIONS – PIC12F519**



**FIGURE 11-4: EXTERNAL CLOCK TIMING – PIC12F519**



# PIC12F519

## 11.3 AC Characteristics

**TABLE 11-5: EXTERNAL CLOCK TIMING REQUIREMENTS**

AC CHARACTERISTICS		Standard Operating Conditions (unless otherwise specified) Operating Temperature $-40^{\circ}\text{C} \leq T_A \leq +85^{\circ}\text{C}$ (industrial), $-40^{\circ}\text{C} \leq T_A \leq +125^{\circ}\text{C}$ (extended) Operating Voltage $V_{DD}$ range is described in Section 11.0 “Electrical Characteristics”					
Param No.	Sym.	Characteristic	Min.	Typ <sup>(1)</sup>	Max.	Units	Conditions
1A	FOSC	External CLKIN Frequency <sup>(2)</sup>	DC	—	4	MHz	XT Oscillator mode
			DC	—	200	kHz	LP Oscillator mode
		Oscillator Frequency <sup>(2)</sup>	DC	—	4	MHz	EXTRC Oscillator mode
			0.1	—	4	MHz	XT Oscillator mode
1	TOSC	External CLKIN Period <sup>(2)</sup>	DC	—	—	ns	XT Oscillator mode
			5	—	—	μs	LP Oscillator mode
		Oscillator Period <sup>(2)</sup>	250	—	—	ns	EXTRC Oscillator mode
			250	—	10,000	ns	XT Oscillator mode
			5	—	—	μs	LP Oscillator mode
2	Tcy	Instruction Cycle Time	200	4/FOSC	DC	ns	
3	TosL, TosH	Clock in (OSC1) Low or High Time	50*	—	—	ns	XT Oscillator
			2*	—	—	μs	LP Oscillator
4	TosR, TosF	Clock in (OSC1) Rise or Fall Time	—	—	25*	ns	XT Oscillator
			—	—	50*	ns	LP Oscillator

\* These parameters are characterized but not tested.

**Note 1:** Data in the Typical (“Typ”) column is at 5V, 25°C unless otherwise stated. These parameters are for design guidance only and are not tested.

**2:** All specified values are based on characterization data for that particular oscillator type under standard operating conditions with the device executing code. Exceeding these specified limits may result in an unstable oscillator operation and/or higher than expected current consumption. When an external clock input is used, the “max” cycle time limit is “DC” (no clock) for all devices.

**TABLE 11-6: CALIBRATED INTERNAL RC FREQUENCIES**

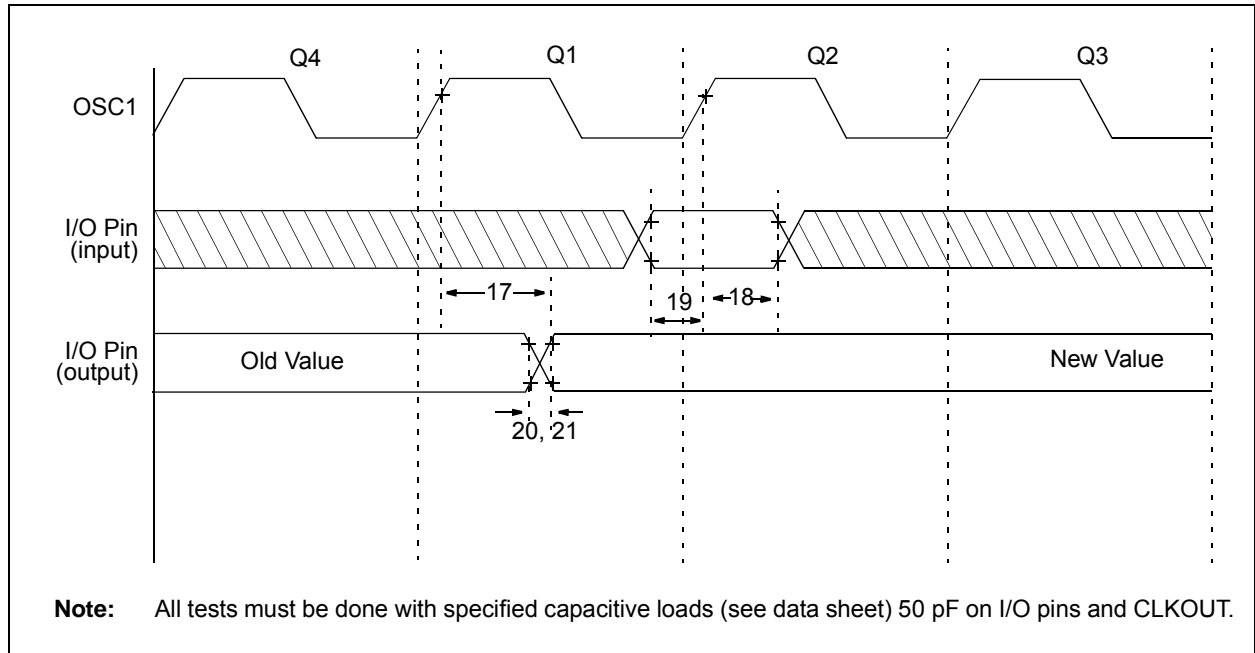
AC CHARACTERISTICS			Standard Operating Conditions (unless otherwise specified)					
			Operating Temperature $-40^{\circ}\text{C} \leq T_A \leq +85^{\circ}\text{C}$ (industrial), $-40^{\circ}\text{C} \leq T_A \leq +125^{\circ}\text{C}$ (extended)					
			Operating Voltage $V_{DD}$ range is described in Section 10.1					
Param No.	Sym.	Characteristic	Freq. Tolerance	Min.	Typ†	Max.	Units	Conditions
F10	FOSC	Internal Calibrated INTOSC Frequency <sup>(1)</sup>	$\pm 1\%$	7.92	8.00	8.08	MHz	3.5V, 25C
			$\pm 2\%$	7.84	8.00	8.16	MHz	$2.5\text{V} \leq V_{DD} \leq 5.5\text{V}$ $0^{\circ}\text{C} \leq T_A \leq +85^{\circ}\text{C}$
			$\pm 5\%$	7.60	8.00	8.40	MHz	$2.0\text{V} \leq V_{DD} \leq 5.5\text{V}$ $-40^{\circ}\text{C} \leq T_A \leq +85^{\circ}\text{C}$ (Ind.) $-40^{\circ}\text{C} \leq T_A \leq +125^{\circ}\text{C}$ (Ext.)

\* These parameters are characterized but not tested.

† Data in the Typical (“Typ”) column is at 5V, 25°C unless otherwise stated. These parameters are for design guidance only and are not tested.

**Note 1:** To ensure these oscillator frequency tolerances,  $V_{DD}$  and  $V_{SS}$  must be capacitively decoupled as close to the device as possible. 0.1 uF and 0.01 uF values in parallel are recommended.

**FIGURE 11-5: I/O TIMING**



# PIC12F519

**TABLE 11-7: TIMING REQUIREMENTS**

AC CHARACTERISTICS		Standard Operating Conditions (unless otherwise specified) Operating Temperature $-40^{\circ}\text{C} \leq T_A \leq +85^{\circ}\text{C}$ (industrial) $-40^{\circ}\text{C} \leq T_A \leq +125^{\circ}\text{C}$ (extended) Operating Voltage $V_{DD}$ range is described in				
Param No.	Sym.	Characteristic	Min.	Typ <sup>(1)</sup>	Max.	Units
17	ToSH2IoV	OSC1 $\uparrow$ (Q1 cycle) to Port Out Valid <sup>(2), (3)</sup>	—	—	100*	ns
18	ToSH2IoI	OSC1 $\uparrow$ (Q2 cycle) to Port Input Invalid (I/O in hold time) <sup>(2)</sup>	50	—	—	ns
19	TioV2osH	Port Input Valid to OSC1 $\uparrow$ (I/O in setup time)	20	—	—	ns
20	TioR	Port Output Rise Time <sup>(3)</sup>	—	10	50**	ns
21	TioF	Port Output Fall Time <sup>(3)</sup>	—	10	50**	ns

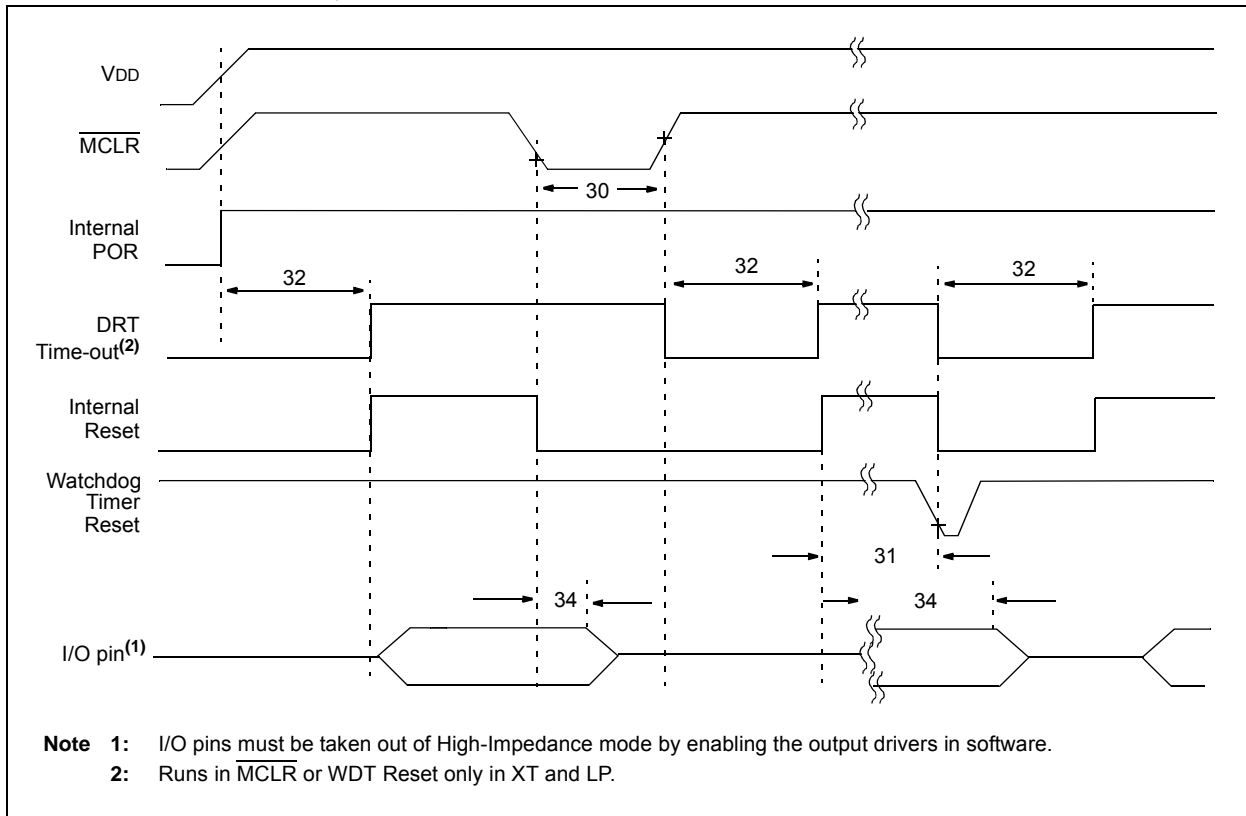
TBD = To be determined.

\* These parameters are characterized but not tested.

\*\* These parameters are design targets and are not tested.

- Note 1:** Data in the Typical (“Typ”) column is at 5V, 25°C unless otherwise stated. These parameters are for design guidance only and are not tested.
- 2:** Measurements are taken in EXTRC mode.
- 3:** See Figure 11-3 for loading conditions.

**FIGURE 11-6: RESET, WATCHDOG TIMER AND DEVICE RESET TIMER TIMING**





**TABLE 11-8: RESET, WATCHDOG TIMER AND DEVICE RESET TIMER – PIC12F519**

AC CHARACTERISTICS		Standard Operating Conditions (unless otherwise specified) Operating Temperature $-40^{\circ}\text{C} \leq T_A \leq +85^{\circ}\text{C}$ (industrial) $-40^{\circ}\text{C} \leq T_A \leq +125^{\circ}\text{C}$ (extended) Operating Voltage $V_{DD}$ range is described in <b>Section TABLE 11-3: “DC CHARACTERISTICS: PIC12F519 (Industrial, Extended)”</b>					
Param No.	Sym.	Characteristic	Min.	Typ <sup>(1)</sup>	Max.	Units	Conditions
30	TMCL	$\overline{\text{MCLR}}$ Pulse Width (low)	2000*	—	—	ns	$V_{DD} = 5.0\text{V}$
31	TWD $\overline{\text{T}}$	Watchdog Timer Time-out Period (no prescaler)	9*	18*	30*	ms	$V_{DD} = 5.0\text{V}$ (Industrial)
			9*	18*	40*	ms	$V_{DD} = 5.0\text{V}$ (Extended)
32	TDRT	Device Reset Timer Period					
		Standard	9*	18*	30*	ms	$V_{DD} = 5.0\text{V}$ (Industrial)
			9*	18*	40*	ms	$V_{DD} = 5.0\text{V}$ (Extended)
		Short	0.5*	1.125*	2*	ms	$V_{DD} = 5.0\text{V}$ (Industrial)
			0.5*	1.125*	2.5*	ms	$V_{DD} = 5.0\text{V}$ (Extended)
34	TIOZ	I/O High-impedance from $\overline{\text{MCLR}}$ low	—	—	2000*	ns	

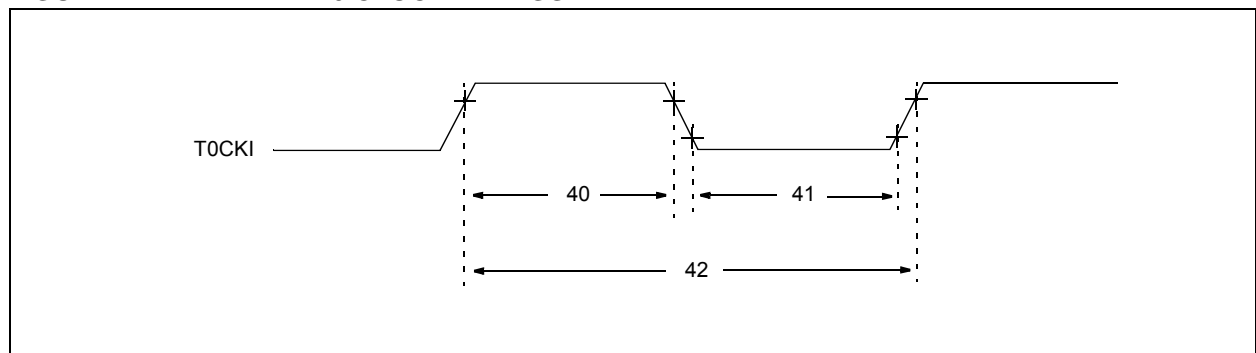
\* These parameters are characterized but not tested.

**Note 1:** Data in the Typical (“Typ”) column is at 5V, 25°C unless otherwise stated. These parameters are for design guidance only and are not tested.

**TABLE 11-9: DRT (DEVICE RESET TIMER PERIOD)**

Oscillator Configuration	POR Reset	Subsequent Resets
IntRC and ExtRC	1 ms (typical)	10 $\mu\text{s}$ (typical)
XT and LP	18 ms (typical)	18 ms (typical)

**FIGURE 11-7: TIMER0 CLOCK TIMINGS**



# PIC12F519

**TABLE 11-10: TIMER0 CLOCK REQUIREMENTS**

AC CHARACTERISTICS		Standard Operating Conditions (unless otherwise specified) Operating Temperature $-40^{\circ}\text{C} \leq T_A \leq +85^{\circ}\text{C}$ (industrial) $-40^{\circ}\text{C} \leq T_A \leq +125^{\circ}\text{C}$ (extended) Operating Voltage $V_{DD}$ range is described in <b>Section TABLE 11-3: "DC CHARACTERISTICS: PIC12F519 (Industrial, Extended)"</b>						
Param No.	Sym.	Characteristic	Min.	Typ <sup>(1)</sup>	Max.	Units	Conditions	
40	Tt0H	T0CKI High Pulse Width	No Prescaler	$0.5 T_{CY} + 20^*$	—	—	ns	
			With Prescaler	$10^*$	—	—	ns	
41	Tt0L	T0CKI Low Pulse Width	No Prescaler	$0.5 T_{CY} + 20^*$	—	—	ns	
			With Prescaler	$10^*$	—	—	ns	
42	Tt0P	T0CKI Period	$20$ or $T_{CY} + 40^* N$	—	—	ns	Whichever is greater. N = Prescale Value (1, 2, 4, ..., 256)	

\* These parameters are characterized but not tested.

**Note 1:** Data in the Typical ("Typ") column is at 5V, 25°C unless otherwise stated. These parameters are for design guidance only and are not tested.

**TABLE 11-11: FLASH DATA MEMORY WRITE/ERASE REQUIREMENTS**

AC CHARACTERISTICS		Standard Operating Conditions (unless otherwise specified) Operating Temperature $-40^{\circ}\text{C} \leq T_A \leq +85^{\circ}\text{C}$ (industrial) $-40^{\circ}\text{C} \leq T_A \leq +125^{\circ}\text{C}$ (extended) Operating Voltage $V_{DD}$ range is described in <b>Section TABLE 11-3: "DC CHARACTERISTICS: PIC12F519 (Industrial, Extended)"</b>						
Param No.	Sym.	Characteristic	Min.	Typ <sup>(1)</sup>	Max.	Units	Conditions	
43	TDW	Flash Data Memory Write Cycle Time	2	3.5	5	ms		
44	TDE	Flash Data Memory Erase Cycle Time	2	3	4	ms		

\* These parameters are characterized but not tested.

**Note 1:** Data in the Typical ("Typ") column is at 5V, 25°C unless otherwise stated. These parameters are for design guidance only and are not tested.

## 12.0 DC AND AC CHARACTERISTICS GRAPHS AND CHARTS

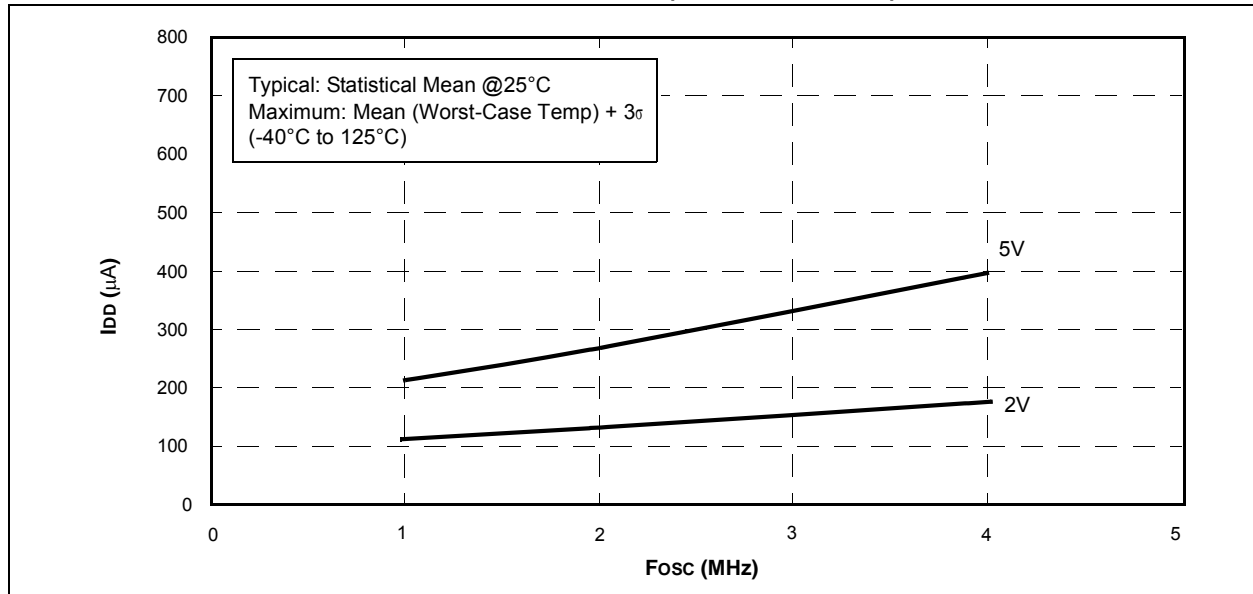
The graphs and tables provided in this section are for **design guidance** and are **not tested**.

In some graphs or tables, the data presented are **outside specified operating range** (i.e., outside specified  $V_{DD}$  range). This is for **information only** and devices are ensured to operate properly only within the specified range.

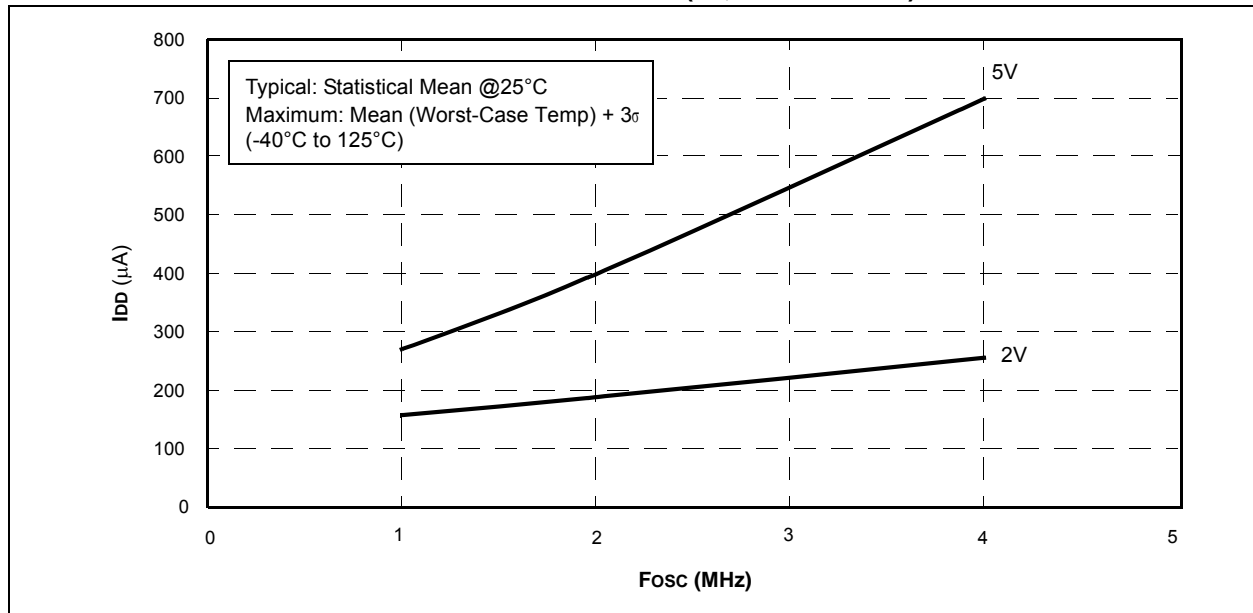
**Note:** The graphs and tables provided following this note are a statistical summary based on a limited number of samples and are provided for informational purposes only. The performance characteristics listed herein are not tested or guaranteed. In some graphs or tables, the data presented may be outside the specified operating range (e.g., outside specified power supply range) and therefore, outside the warranted range.

“Typical” represents the mean of the distribution at 25°C. “Maximum” or “minimum” represents (mean + 3 $\sigma$ ) or (mean - 3 $\sigma$ ) respectively, where  $\sigma$  is a standard deviation, over each temperature range.

**FIGURE 12-1: TYPICAL  $I_{DD}$  vs. Fosc OVER  $V_{DD}$  (XT, EXTRC mode)**

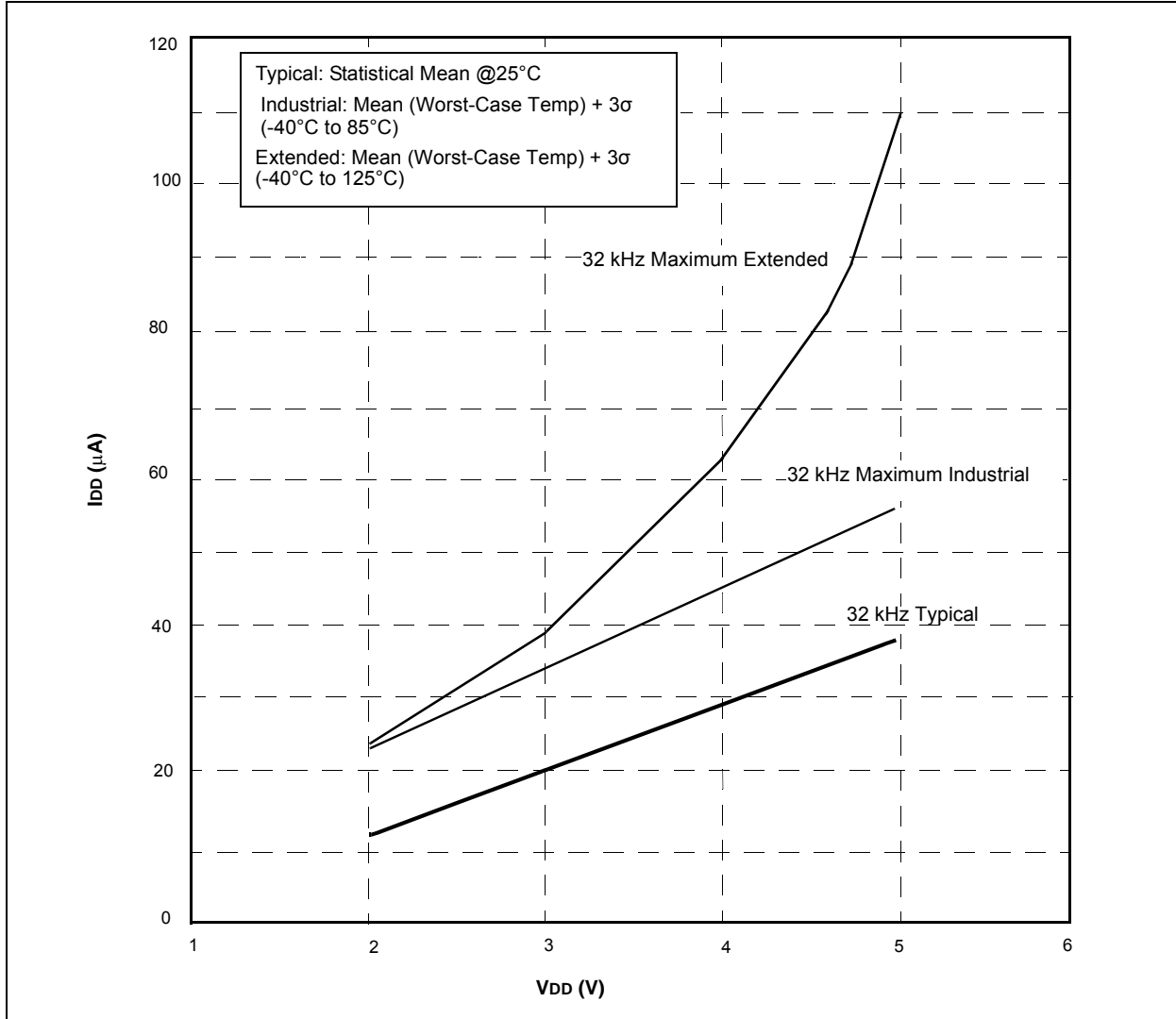


**FIGURE 12-2: MAXIMUM  $I_{DD}$  vs. Fosc OVER  $V_{DD}$  (XT, EXTRC mode)**

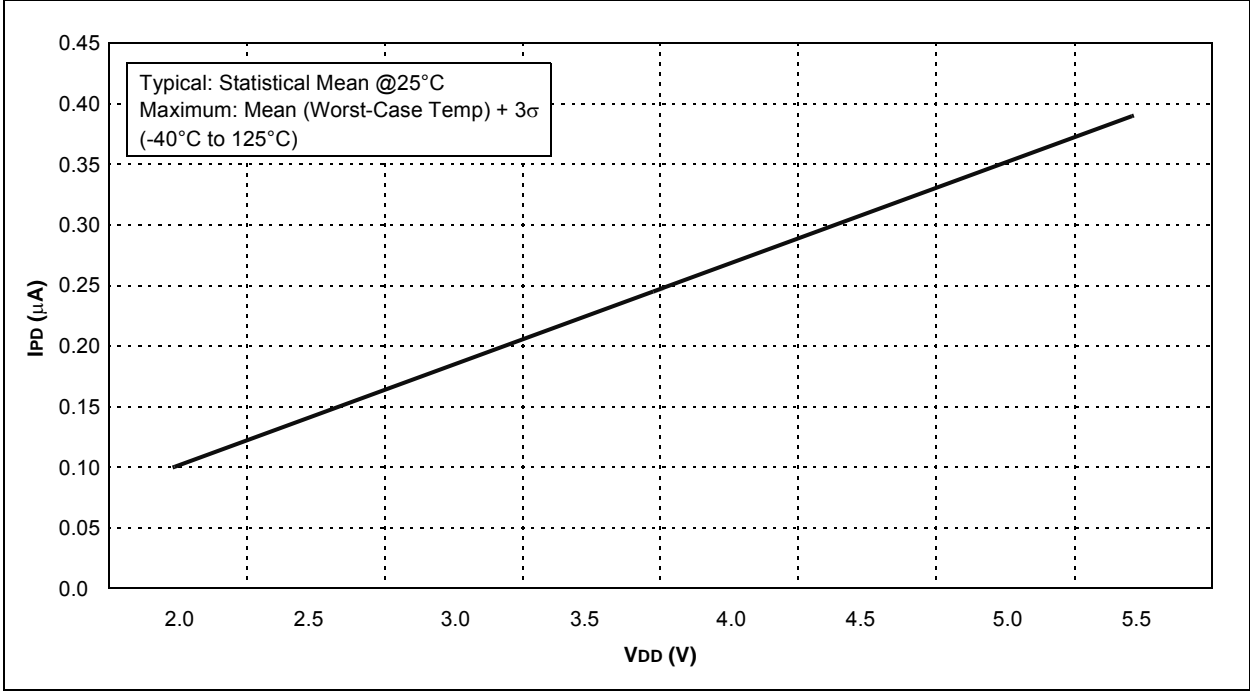


# PIC12F519

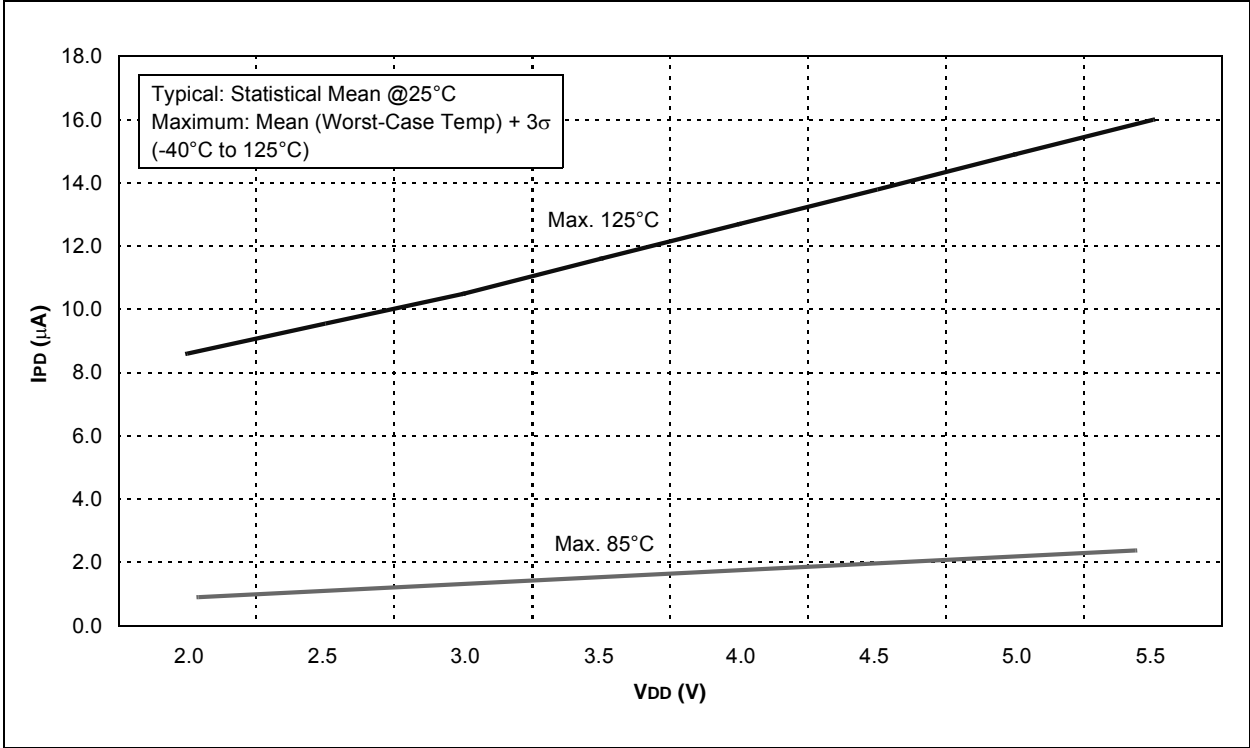
FIGURE 12-3:  $I_{DD}$  vs.  $V_{DD}$  OVER  $F_{osc}$  (LP MODE)



**FIGURE 12-4: TYPICAL IPD vs. VDD (SLEEP MODE, ALL PERIPHERALS DISABLED)**



**FIGURE 12-5: MAXIMUM IPD vs. VDD (SLEEP MODE, ALL PERIPHERALS DISABLED)**



# PIC12F519

FIGURE 12-6: TYPICAL WDT IPD vs. VDD

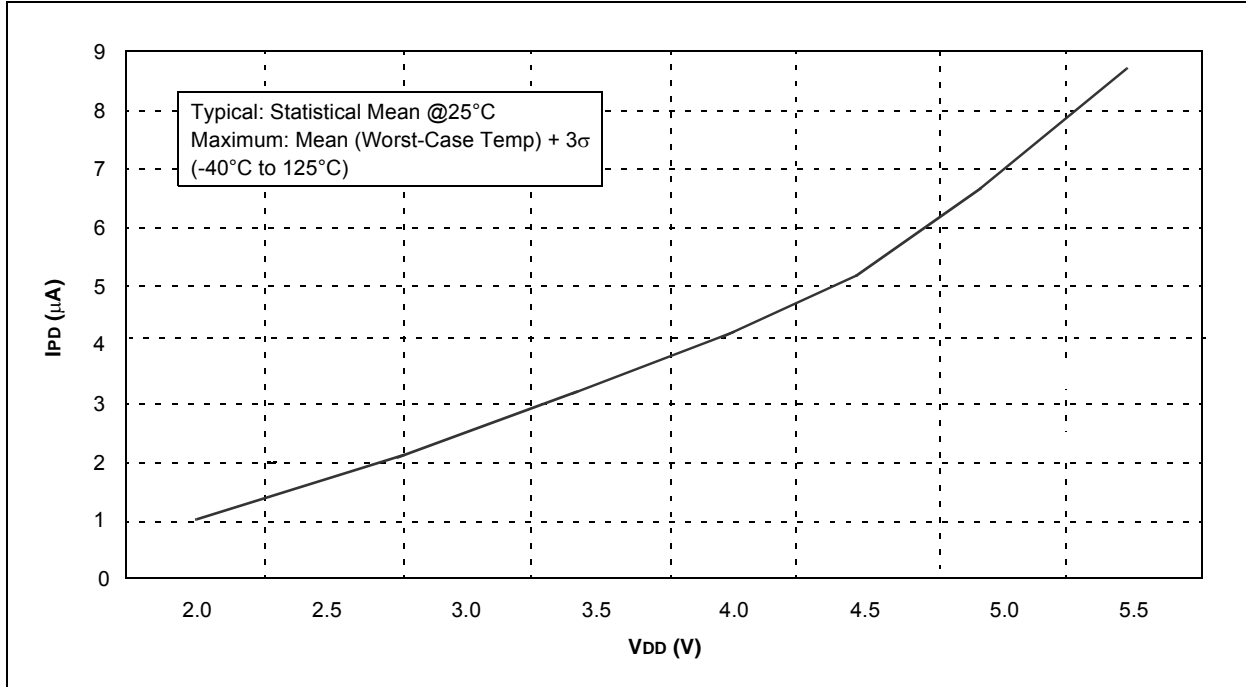
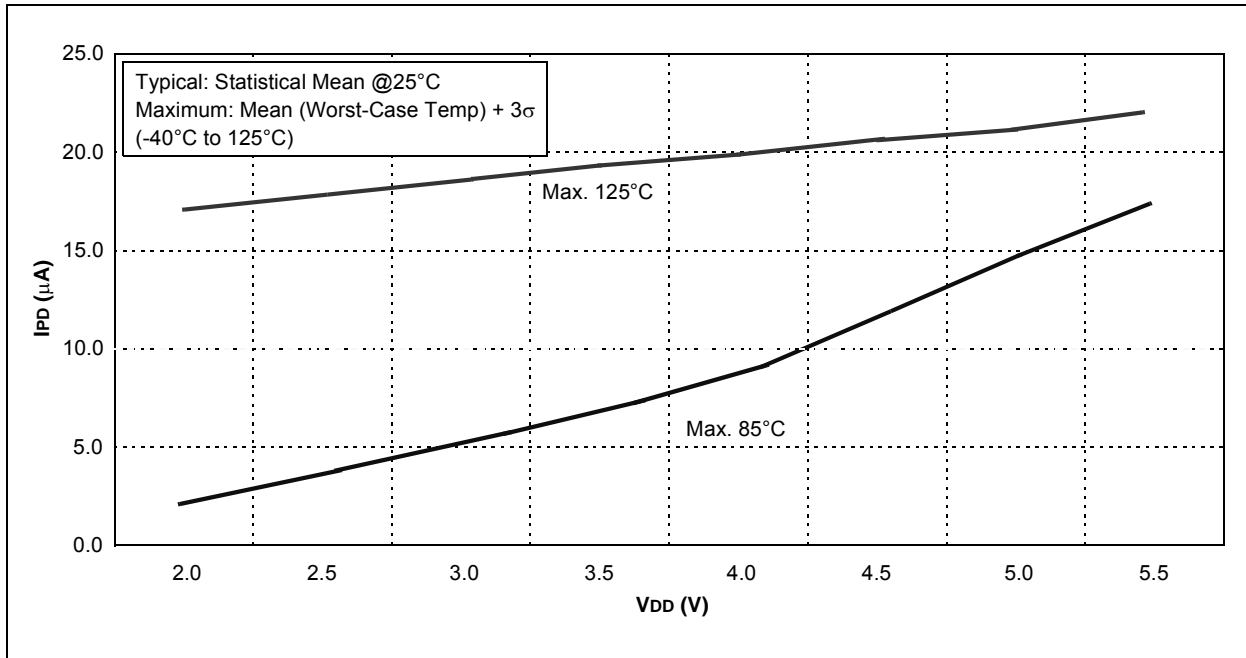
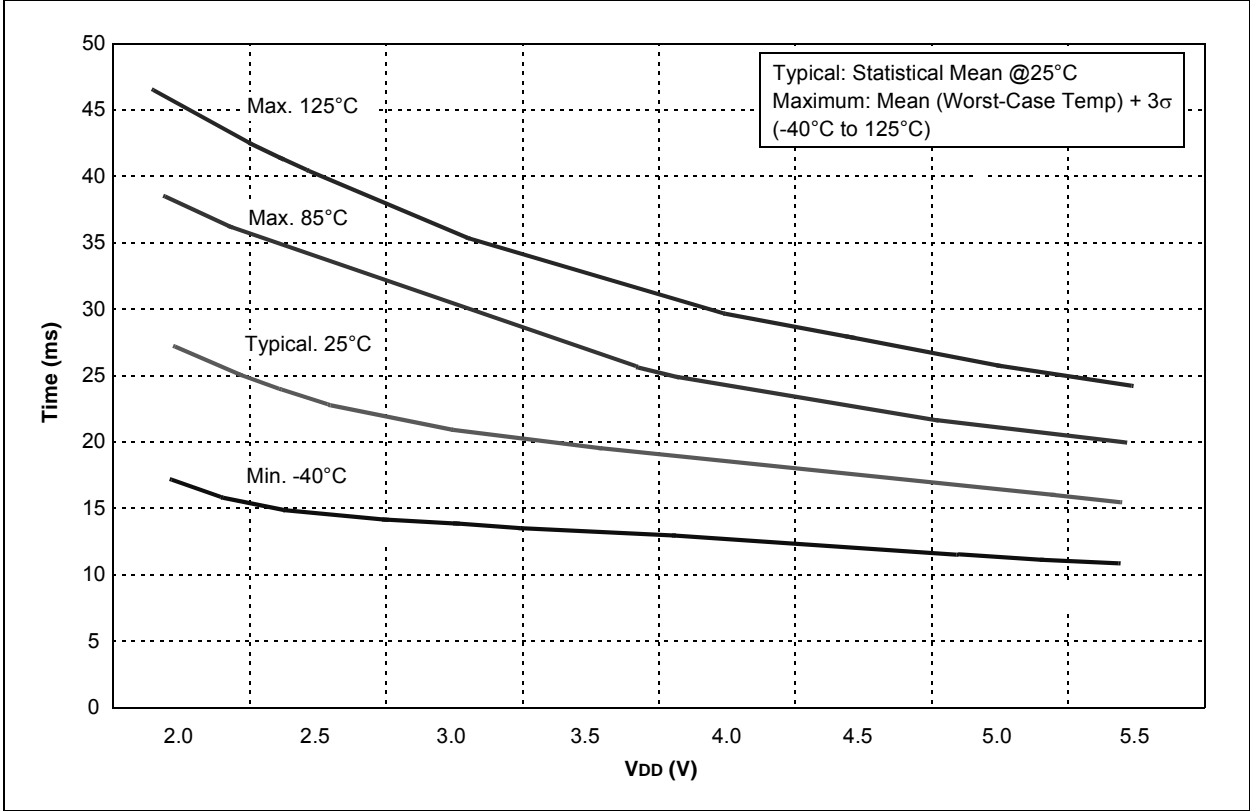


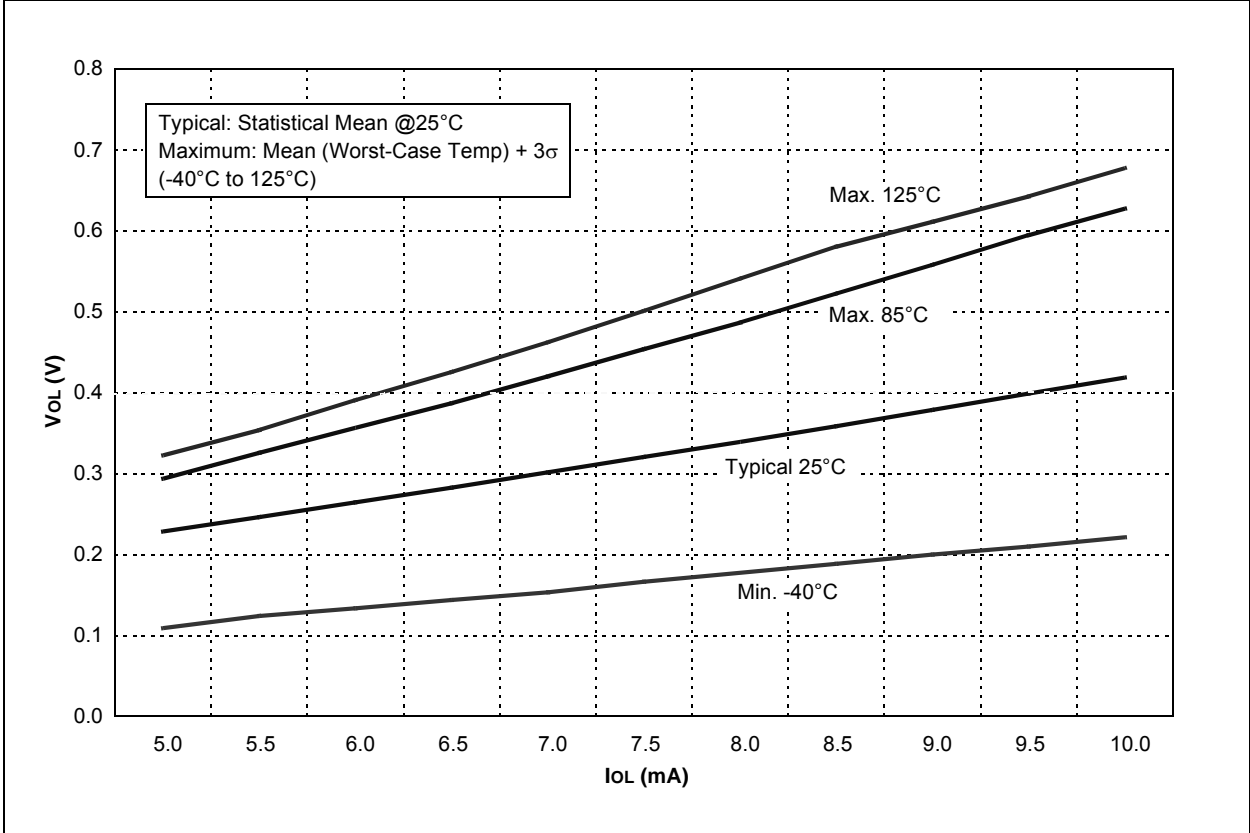
FIGURE 12-7: MAXIMUM WDT IPD vs. VDD OVER TEMPERATURE



**FIGURE 12-8: WDT TIME-OUT vs. VDD OVER TEMPERATURE (NO PRESCALER)**

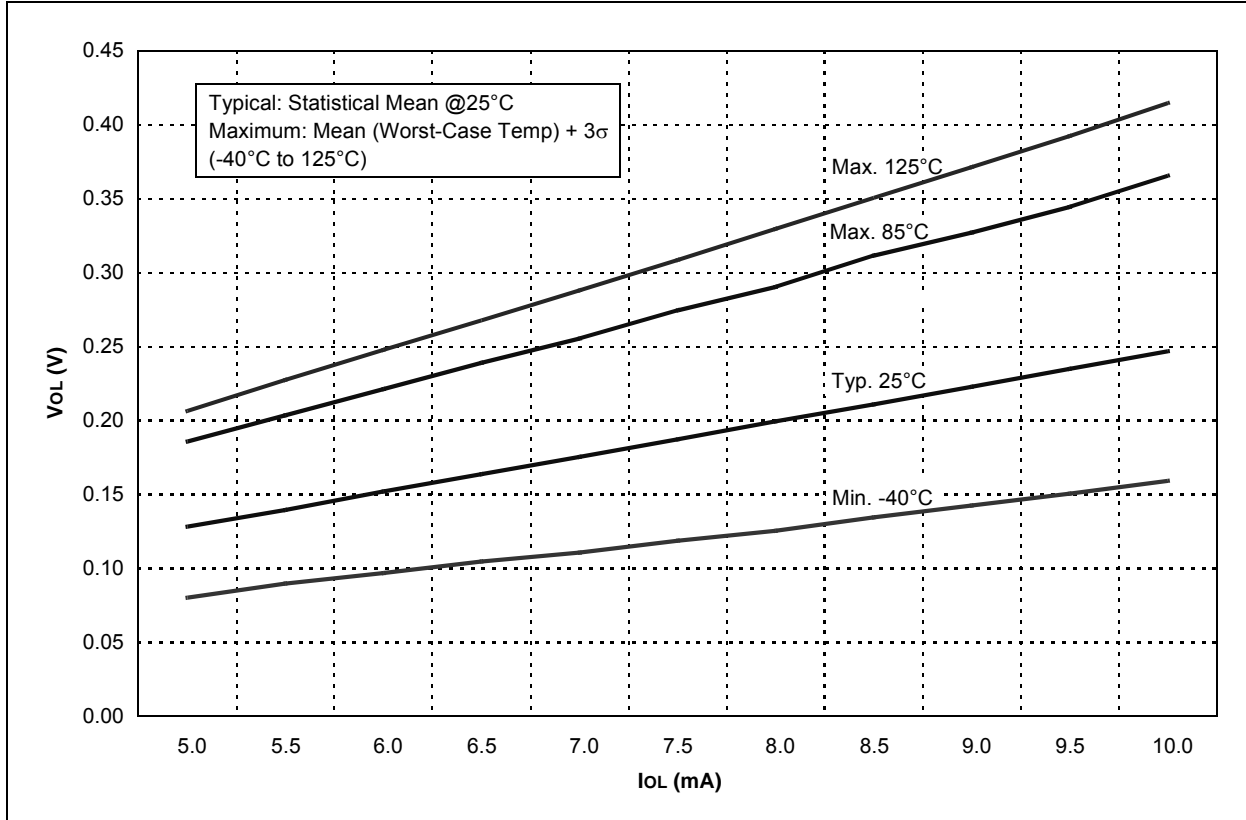


**FIGURE 12-9: VOL vs. IOL OVER TEMPERATURE (VDD = 3.0V)**

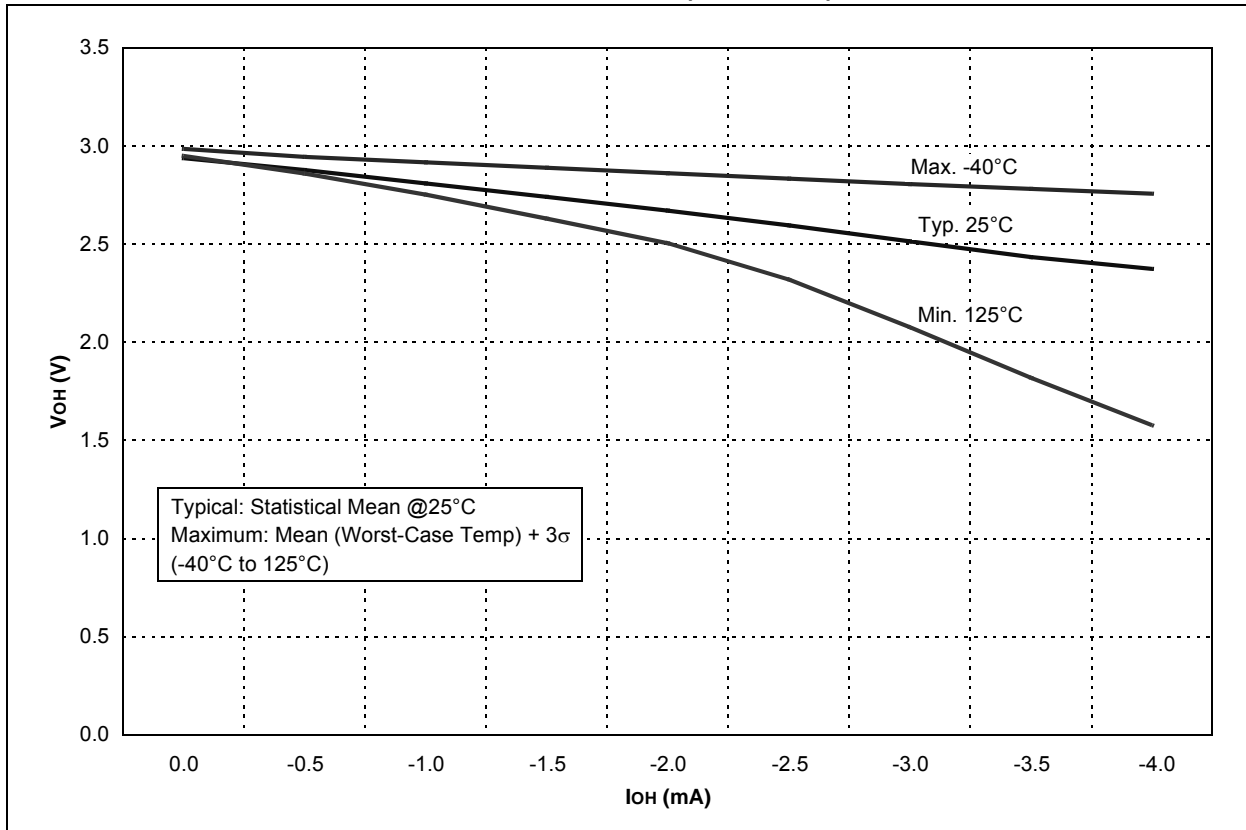


# PIC12F519

**FIGURE 12-10:  $V_{OL}$  vs.  $I_{OL}$  OVER TEMPERATURE ( $V_{DD} = 5.0V$ )**

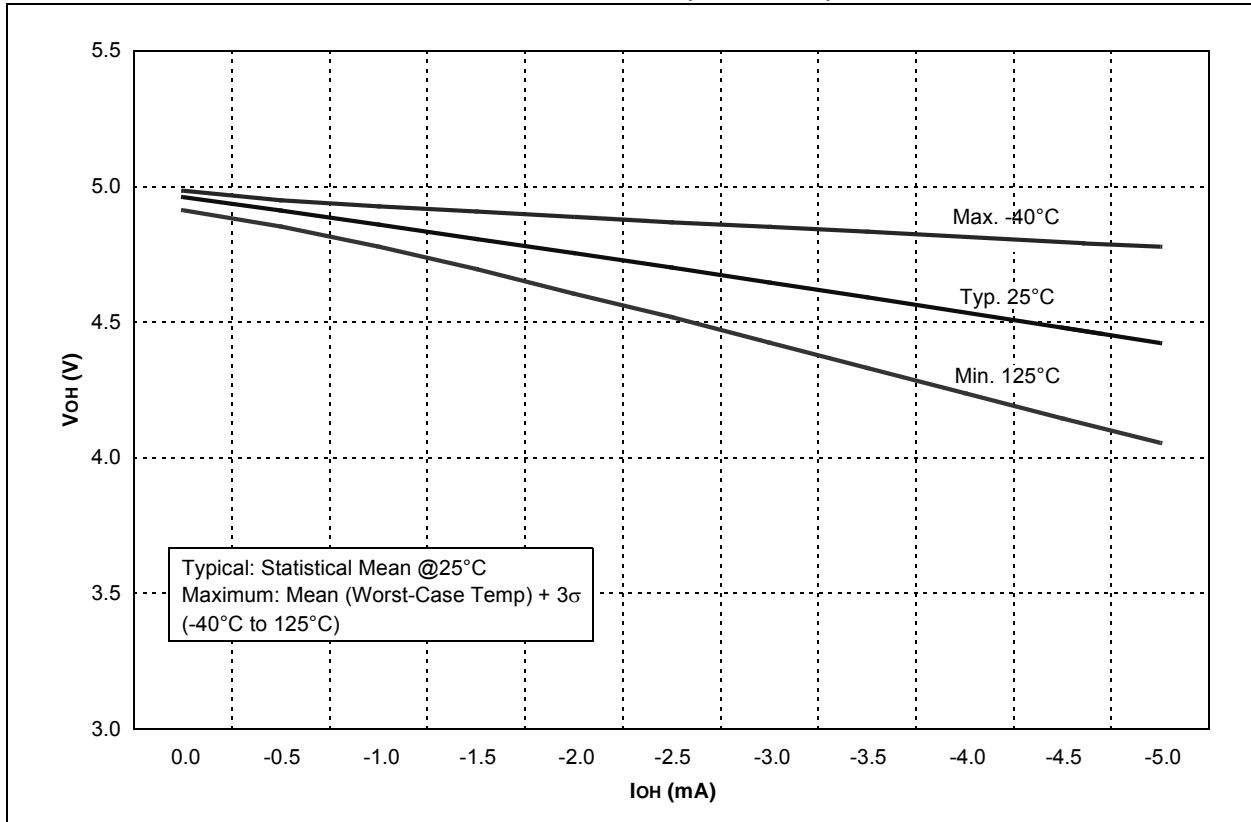


**FIGURE 12-11:  $V_{OH}$  vs.  $I_{OH}$  OVER TEMPERATURE ( $V_{DD} = 3.0V$ )**

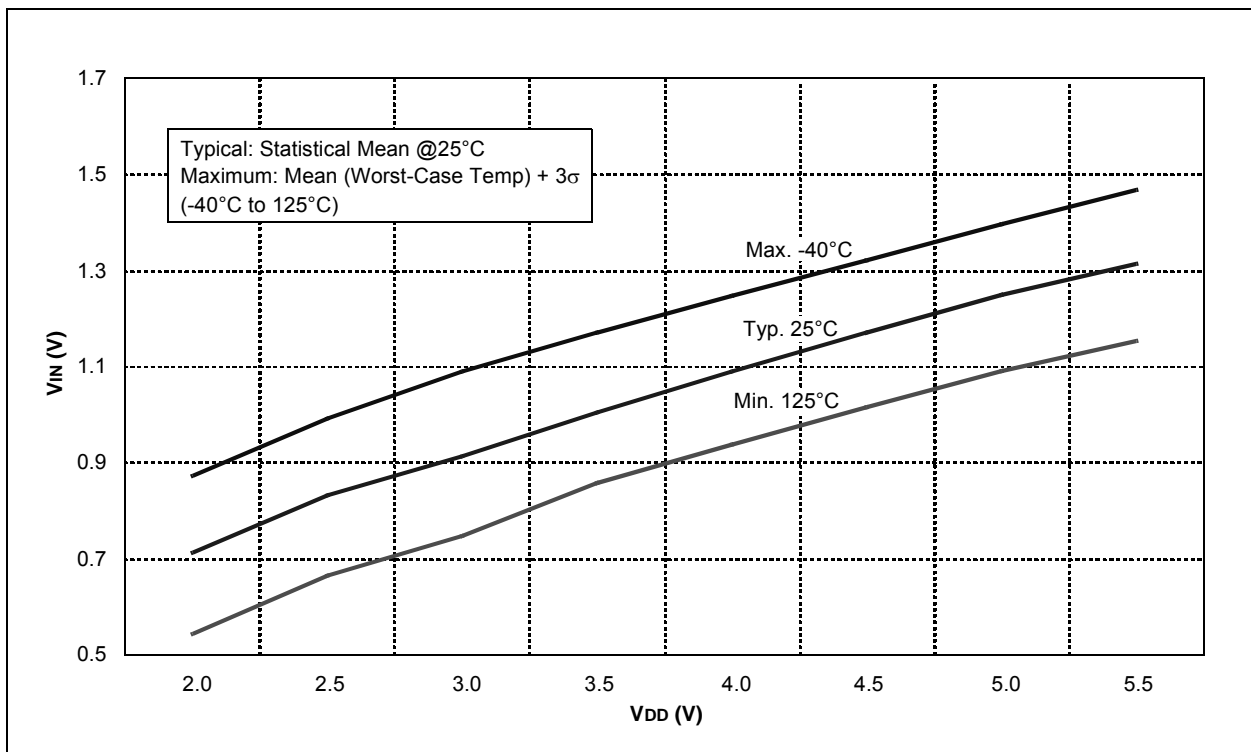




**FIGURE 12-12:  $V_{OH}$  vs.  $I_{OH}$  OVER TEMPERATURE ( $V_{DD} = 5.0V$ )**



**FIGURE 12-13: TTL INPUT THRESHOLD  $V_{IN}$  vs.  $V_{DD}$**



# PIC12F519

FIGURE 12-14: SCHMITT TRIGGER INPUT THRESHOLD  $V_{IN}$  vs.  $V_{DD}$

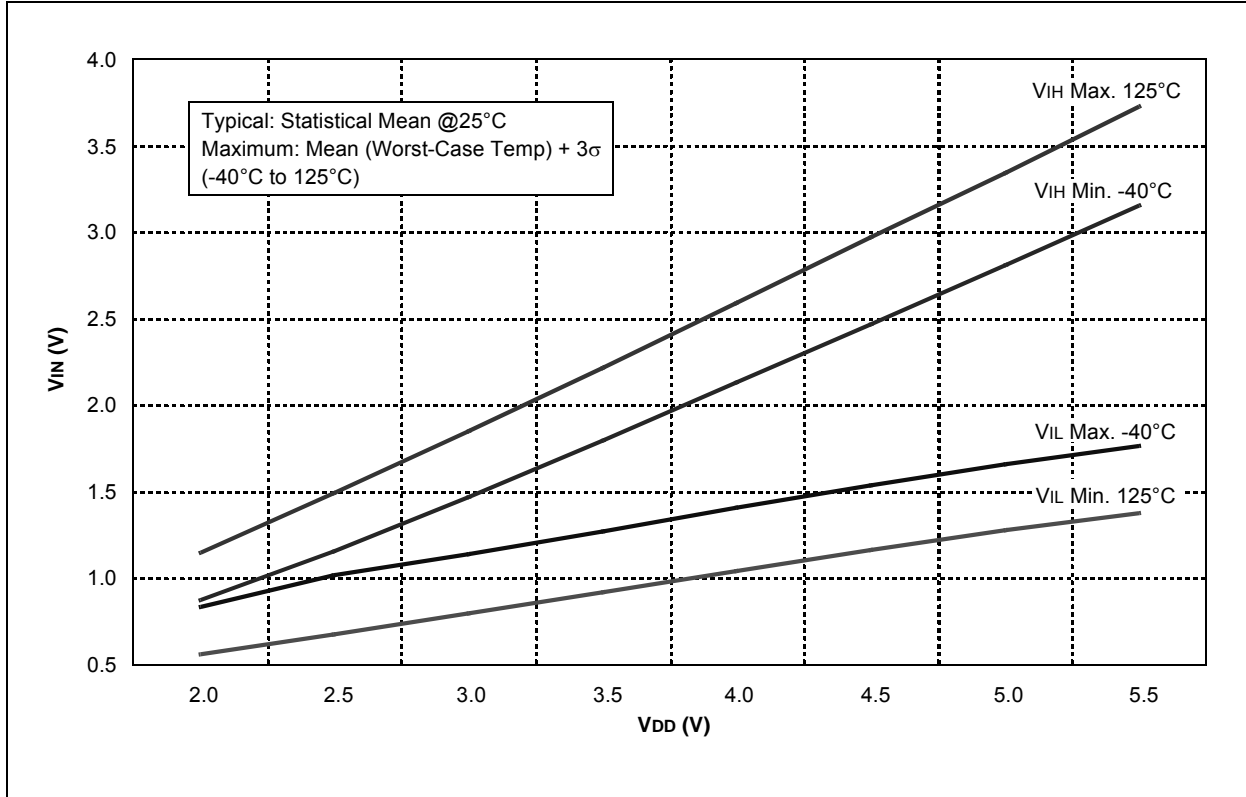
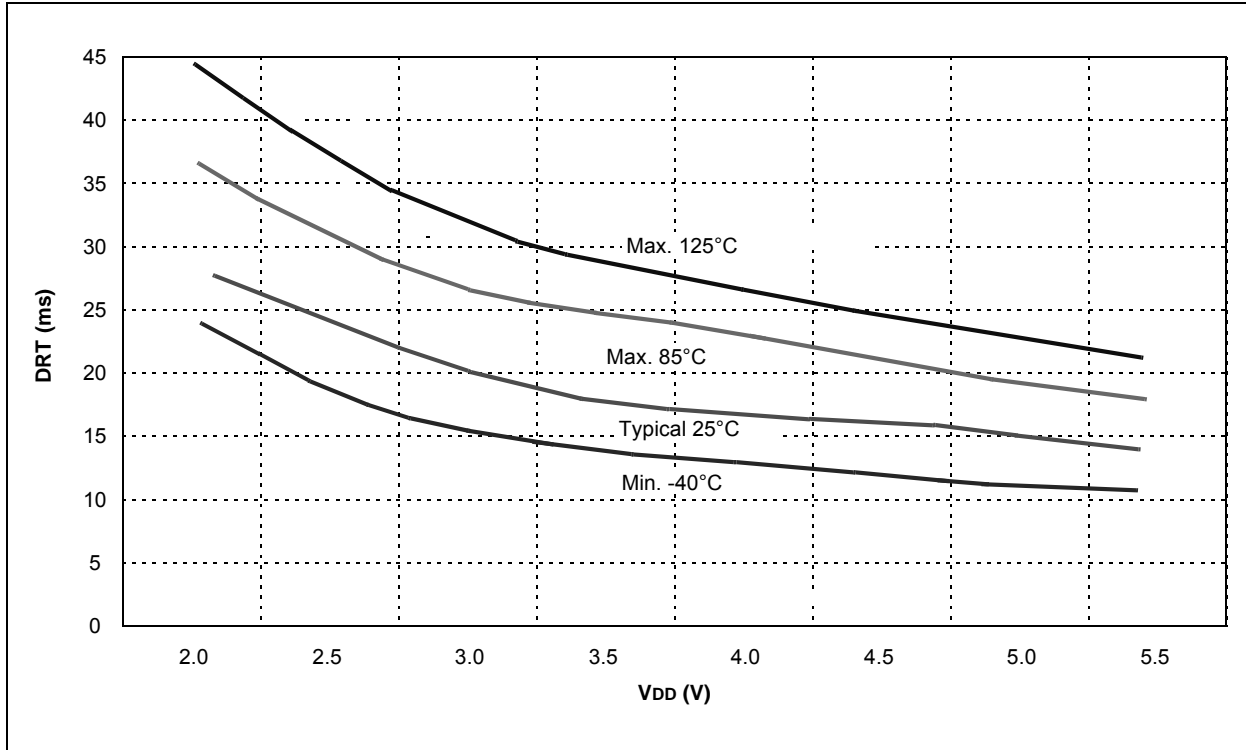


FIGURE 12-15: DEVICE RESET TIMER (XT AND LP) vs.  $V_{DD}$



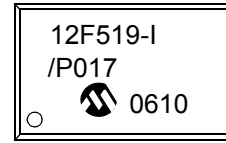
## 13.0 PACKAGING INFORMATION

### 13.1 Package Marking Information

8-Lead PDIP



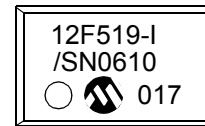
Example



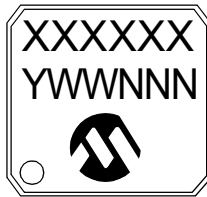
8-Lead SOIC (3.90 mm)



Example



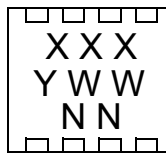
8-Lead MSOP



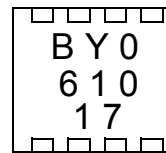
Example



8-Lead 2x3 DFN\*



Example



<b>Legend:</b>	XX...X	Customer-specific information
	Y	Year code (last digit of calendar year)
	YY	Year code (last 2 digits of calendar year)
	WW	Week code (week of January 1 is week '01')
	NNN	Alphanumeric traceability code
	(e3)	Pb-free JEDEC designator for Matte Tin (Sn)
	*	This package is Pb-free. The Pb-free JEDEC designator (e3) can be found on the outer packaging for this package.

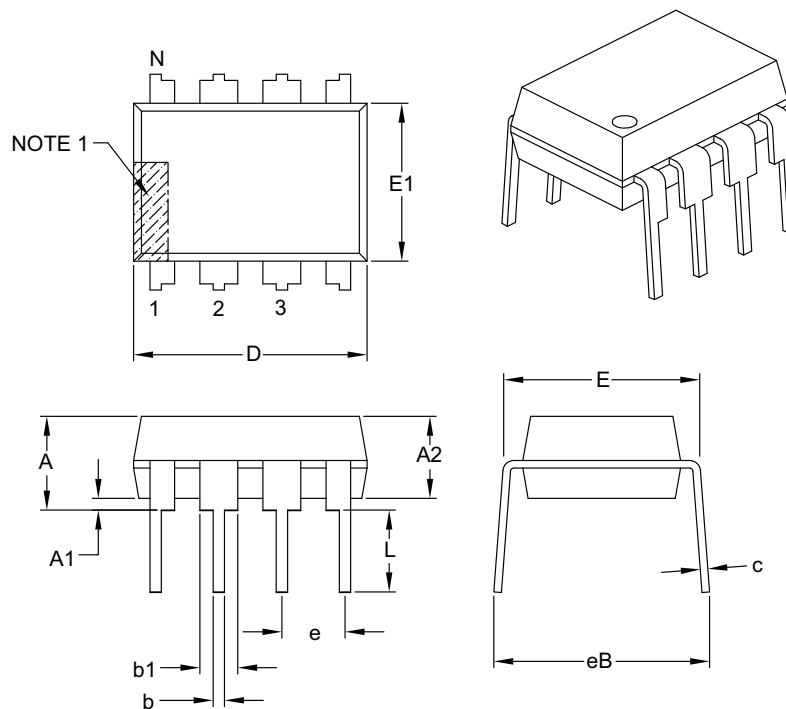
**Note:** In the event the full Microchip part number cannot be marked on one line, it will be carried over to the next line, thus limiting the number of available characters for customer-specific information.

\* Standard PIC® device marking consists of Microchip part number, year code, week code, and traceability code. For PIC device marking beyond this, certain price adders apply. Please check with your Microchip Sales Office. For QTP devices, any special marking adders are included in QTP price.

# PIC12F519

## 8-Lead Plastic Dual In-Line (P) – 300 mil Body [PDIP]

**Note:** For the most current package drawings, please see the Microchip Packaging Specification located at <http://www.microchip.com/packaging>



Dimension Limits	Units	INCHES		
		MIN	NOM	MAX
Number of Pins	N	8		
Pitch	e	.100 BSC		
Top to Seating Plane	A	–	–	.210
Molded Package Thickness	A2	.115	.130	.195
Base to Seating Plane	A1	.015	–	–
Shoulder to Shoulder Width	E	.290	.310	.325
Molded Package Width	E1	.240	.250	.280
Overall Length	D	.348	.365	.400
Tip to Seating Plane	L	.115	.130	.150
Lead Thickness	c	.008	.010	.015
Upper Lead Width	b1	.040	.060	.070
Lower Lead Width	b	.014	.018	.022
Overall Row Spacing §	eB	–	–	.430

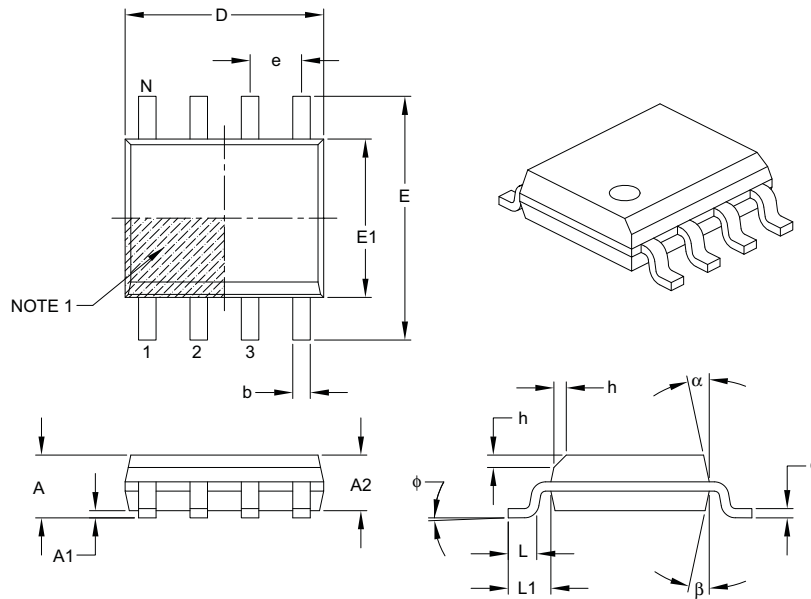
**Notes:**

- Pin 1 visual index feature may vary, but must be located with the hatched area.
- § Significant Characteristic.
- Dimensions D and E1 do not include mold flash or protrusions. Mold flash or protrusions shall not exceed .010" per side.
- Dimensioning and tolerancing per ASME Y14.5M.  
BSC: Basic Dimension. Theoretically exact value shown without tolerances.

Microchip Technology Drawing C04-018B

## 8-Lead Plastic Small Outline (SN) – Narrow, 3.90 mm Body [SOIC]

**Note:** For the most current package drawings, please see the Microchip Packaging Specification located at <http://www.microchip.com/packaging>



Dimension Limits	Units	MILLIMETERS		
		MIN	NOM	MAX
Number of Pins	N	8		
Pitch	e	1.27 BSC		
Overall Height	A	–	–	1.75
Molded Package Thickness	A2	1.25	–	–
Standoff §	A1	0.10	–	0.25
Overall Width	E	6.00 BSC		
Molded Package Width	E1	3.90 BSC		
Overall Length	D	4.90 BSC		
Chamfer (optional)	h	0.25	–	0.50
Foot Length	L	0.40	–	1.27
Footprint	L1	1.04 REF		
Foot Angle	$\phi$	0°	–	8°
Lead Thickness	c	0.17	–	0.25
Lead Width	b	0.31	–	0.51
Mold Draft Angle Top	$\alpha$	5°	–	15°
Mold Draft Angle Bottom	$\beta$	5°	–	15°

**Notes:**

- Pin 1 visual index feature may vary, but must be located within the hatched area.
- § Significant Characteristic.
- Dimensions D and E1 do not include mold flash or protrusions. Mold flash or protrusions shall not exceed 0.15 mm per side.
- Dimensioning and tolerancing per ASME Y14.5M.

BSC: Basic Dimension. Theoretically exact value shown without tolerances.

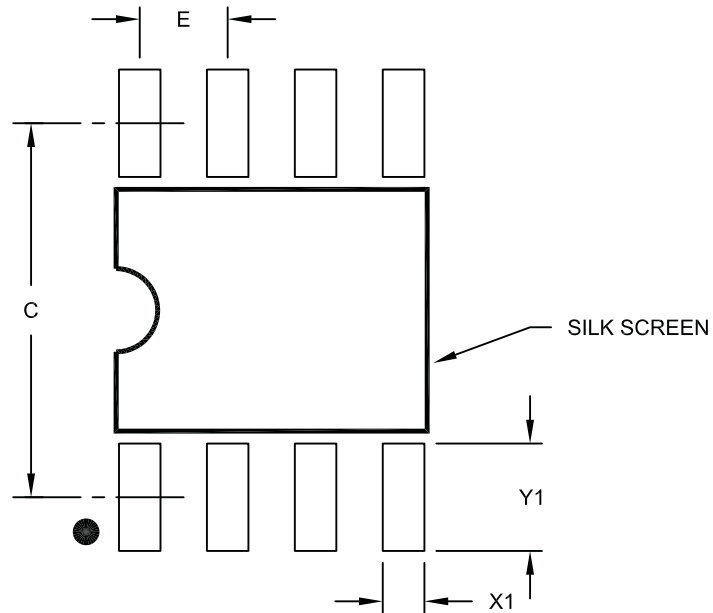
REF: Reference Dimension, usually without tolerance, for information purposes only.

Microchip Technology Drawing C04-057B

# PIC12F519

## 8-Lead Plastic Small Outline (SN) – Narrow, 3.90 mm Body [SOIC]

**Note:** For the most current package drawings, please see the Microchip Packaging Specification located at <http://www.microchip.com/packageing>



RECOMMENDED LAND PATTERN

		Units	MILLIMETERS		
		Dimension Limits	MIN	NOM	MAX
Contact Pitch	E		1.27 BSC		
Contact Pad Spacing	C		5.40		
Contact Pad Width (X8)	X1				0.60
Contact Pad Length (X8)	Y1				1.55

Notes:

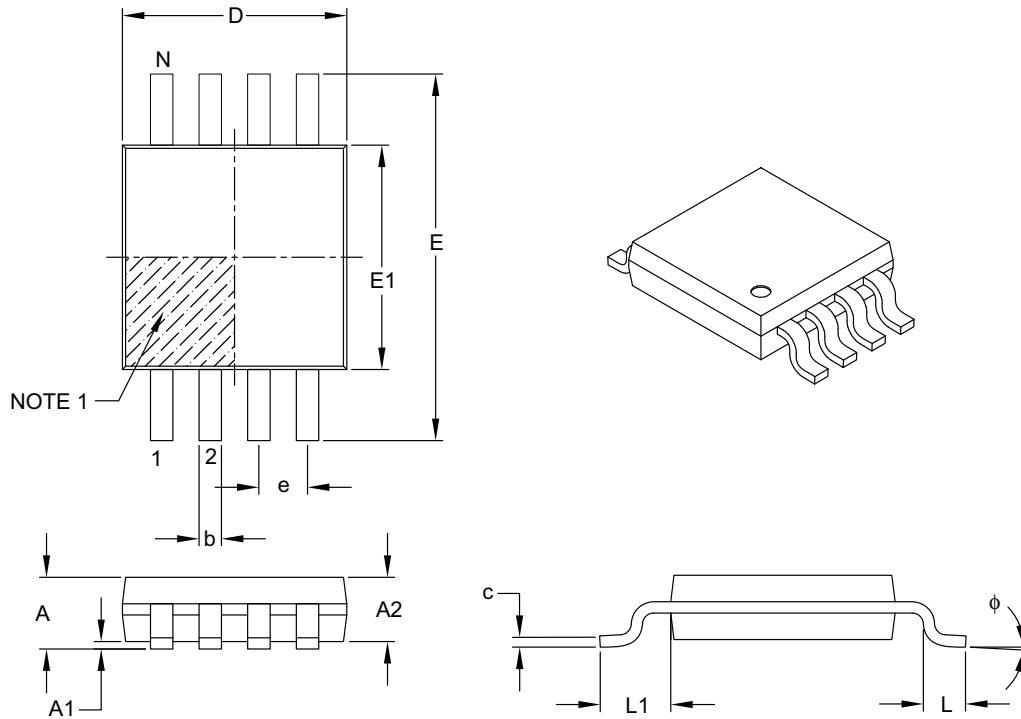
1. Dimensioning and tolerancing per ASME Y14.5M

BSC: Basic Dimension. Theoretically exact value shown without tolerances.

Microchip Technology Drawing No. C04-2057A

## 8-Lead Plastic Micro Small Outline Package (MS) [MSOP]

**Note:** For the most current package drawings, please see the Microchip Packaging Specification located at <http://www.microchip.com/packaging>



Dimension Limits	Units	MILLIMETERS		
		MIN	NOM	MAX
Number of Pins	N	8		
Pitch	e	0.65 BSC		
Overall Height	A	–	–	1.10
Molded Package Thickness	A2	0.75	0.85	0.95
Standoff	A1	0.00	–	0.15
Overall Width	E	4.90 BSC		
Molded Package Width	E1	3.00 BSC		
Overall Length	D	3.00 BSC		
Foot Length	L	0.40	0.60	0.80
Footprint	L1	0.95 REF		
Foot Angle	$\phi$	0°	–	8°
Lead Thickness	c	0.08	–	0.23
Lead Width	b	0.22	–	0.40

**Notes:**

- Pin 1 visual index feature may vary, but must be located within the hatched area.
- Dimensions D and E1 do not include mold flash or protrusions. Mold flash or protrusions shall not exceed 0.15 mm per side.
- Dimensioning and tolerancing per ASME Y14.5M.

BSC: Basic Dimension. Theoretically exact value shown without tolerances.

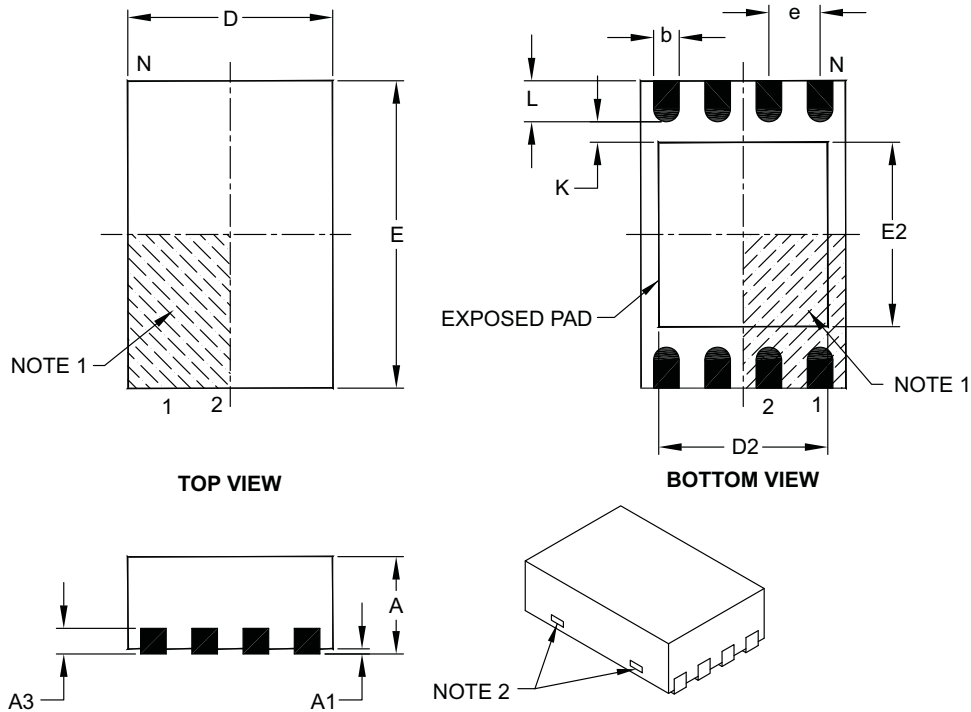
REF: Reference Dimension, usually without tolerance, for information purposes only.

Microchip Technology Drawing C04-111B

# PIC12F519

## 8-Lead Plastic Dual Flat, No Lead Package (MC) – 2x3x0.9 mm Body [DFN]

**Note:** For the most current package drawings, please see the Microchip Packaging Specification located at <http://www.microchip.com/packaging>



Dimension Limits	Units	MILLIMETERS		
		MIN	NOM	MAX
Number of Pins	N	8		
Pitch	e	0.50 BSC		
Overall Height	A	0.80	0.90	1.00
Standoff	A1	0.00	0.02	0.05
Contact Thickness	A3	0.20 REF		
Overall Length	D	2.00 BSC		
Overall Width	E	3.00 BSC		
Exposed Pad Length	D2	1.30	–	1.55
Exposed Pad Width	E2	1.50	–	1.75
Contact Width	b	0.20	0.25	0.30
Contact Length	L	0.30	0.40	0.50
Contact-to-Exposed Pad	K	0.20	–	–

**Notes:**

- Pin 1 visual index feature may vary, but must be located within the hatched area.
- Package may have one or more exposed tie bars at ends.
- Package is saw singulated.
- Dimensioning and tolerancing per ASME Y14.5M.

BSC: Basic Dimension. Theoretically exact value shown without tolerances.

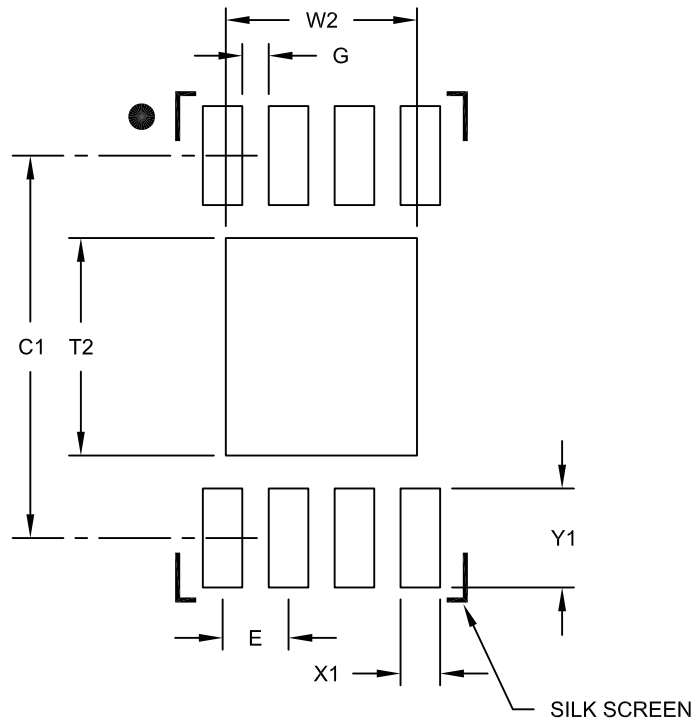
REF: Reference Dimension, usually without tolerance, for information purposes only.

Microchip Technology Drawing C04-123C



## 8-Lead Plastic Dual Flat, No Lead Package (MC) – 2x3x0.9 mm Body [DFN]

**Note:** For the most current package drawings, please see the Microchip Packaging Specification located at <http://www.microchip.com/packaging>



RECOMMENDED LAND PATTERN

Dimension Limits	Units	MILLIMETERS		
		MIN	NOM	MAX
Contact Pitch	E	0.50 BSC		
Optional Center Pad Width	W2			1.45
Optional Center Pad Length	T2			1.75
Contact Pad Spacing	C1		2.90	
Contact Pad Width (X8)	X1			0.30
Contact Pad Length (X8)	Y1			0.75
Distance Between Pads	G	0.20		

**Notes:**

1. Dimensioning and tolerancing per ASME Y14.5M

BSC: Basic Dimension. Theoretically exact value shown without tolerances.

Microchip Technology Drawing No. C04-2123A

# PIC12F519

---

## APPENDIX A: REVISION HISTORY

### Revision A (May 2007)

Original release of this document.

### Revision B (September 2008)

Added DC and AC Characteristics graphs; Updated Electrical Characteristics section; Updated Package Drawings and made general edits.

## INDEX

### A

ALU .....	9
Assembler	
MPASM Assembler .....	58

### B

Block Diagram	
On-Chip Reset Circuit .....	43
Timer0 .....	31
TMR0/WDT Prescaler .....	35
Watchdog Timer .....	46

### C

C Compilers	
MPLAB C18 .....	58
MPLAB C30 .....	58
Carry .....	9
Clocking Scheme .....	12
Code Protection .....	37, 48
CONFIG1 Register .....	38
Configuration Bits .....	37
Customer Change Notification Service .....	91
Customer Notification Service .....	91
Customer Support .....	91

### D

DC and AC Characteristics .....	73
Graphs and Tables .....	73
Development Support .....	57
Digit Carry .....	9

### E

Errata .....	3
--------------	---

### F

FSR .....	20
FSR Register .....	20
Fuses. See Configuration Bits	

### G

GPIO .....	23
------------	----

### I

I/O Interfacing .....	25
I/O Port .....	23
I/O Ports .....	23
I/O Programming Considerations .....	30
ID Locations .....	37, 48
INDF .....	20
INDF Register .....	20
Indirect Data Addressing .....	20
Instruction Cycle .....	12
Instruction Flow/Pipelining .....	12
Instruction Set Summary .....	50
Internet Address .....	91

### L

Loading of PC .....	19
---------------------	----

### M

Memory Map	
PIC12F519 .....	13
Memory Organization .....	13
Data EEPROM Memory .....	21
Program Memory (PIC12F519) .....	13
Microchip Internet Web Site .....	91
MPLAB ASM30 Assembler, Linker, Librarian .....	58
MPLAB ICD 2 In-Circuit Debugger .....	59
MPLAB ICE 2000 High-Performance Universal In-Circuit Emulator .....	59
MPLAB Integrated Development Environment Software .....	57
MPLAB PM3 Device Programmer .....	59
MPLAB REAL ICE In-Circuit Emulator System .....	59
MPLINK Object Linker/MPLIB Object Librarian .....	58

### O

OPTION Register .....	17
OSC selection .....	37
OSCCAL Register .....	18
Oscillator Configurations .....	39
Oscillator Types	
HS .....	39
LP .....	39
RC .....	39
XT .....	39

### P

PIC12F519 Device Varieties .....	7
PICSTART Plus Development Programmer .....	60
POR	
Device Reset Timer (DRT) .....	37, 45
PD .....	47
TO .....	47
Power-down Mode .....	47
Prescaler .....	34
Program Counter .....	19

### Q

Q cycles .....	12
----------------	----

### R

RC Oscillator .....	40
Reader Response .....	92
Read-Modify-Write .....	30
Register File Map	
PIC16C57/CR57 .....	14
Registers	
CONFIG1 (Configuration Word Register 1) .....	38
Special Function .....	14
Reset .....	37

### S

Sleep .....	37, 47
Software Simulator (MPLAB SIM) .....	58
Special Features of the CPU .....	37
Special Function Registers .....	14
Stack .....	19
STATUS Register .....	9, 16

# PIC12F519

---

## T

Timer0	
Timer0 (TMR0) Module .....	31
TMR0 with External Clock.....	33
Timing Diagrams and Specifications .....	67
Timing Parameter Symbology and Load Conditions.....	67
TRIS Registers.....	23

## W

Wake-up from Sleep .....	47
Watchdog Timer (WDT) .....	37, 45
Period.....	45
Programming Considerations .....	45
WWW Address.....	91
WWW, On-Line Support.....	3

## Z

Zero bit.....	9
---------------	---

## THE MICROCHIP WEB SITE

Microchip provides online support via our WWW site at [www.microchip.com](http://www.microchip.com). This web site is used as a means to make files and information easily available to customers. Accessible by using your favorite Internet browser, the web site contains the following information:

- **Product Support** – Data sheets and errata, application notes and sample programs, design resources, user's guides and hardware support documents, latest software releases and archived software
- **General Technical Support** – Frequently Asked Questions (FAQ), technical support requests, online discussion groups, Microchip consultant program member listing
- **Business of Microchip** – Product selector and ordering guides, latest Microchip press releases, listing of seminars and events, listings of Microchip sales offices, distributors and factory representatives

## CUSTOMER CHANGE NOTIFICATION SERVICE

Microchip's customer notification service helps keep customers current on Microchip products. Subscribers will receive e-mail notification whenever there are changes, updates, revisions or errata related to a specified product family or development tool of interest.

To register, access the Microchip web site at [www.microchip.com](http://www.microchip.com), click on Customer Change Notification and follow the registration instructions.

## CUSTOMER SUPPORT

Users of Microchip products can receive assistance through several channels:

- Distributor or Representative
- Local Sales Office
- Field Application Engineer (FAE)
- Technical Support
- Development Systems Information Line

Customers should contact their distributor, representative or field application engineer (FAE) for support. Local sales offices are also available to help customers. A listing of sales offices and locations is included in the back of this document.

**Technical support is available through the web site at: <http://support.microchip.com>**

# PIC12F519

---

---

## READER RESPONSE

It is our intention to provide you with the best documentation possible to ensure successful use of your Microchip product. If you wish to provide your comments on organization, clarity, subject matter, and ways in which our documentation can better serve you, please FAX your comments to the Technical Publications Manager at (480) 792-4150.

Please list the following information, and use this outline to provide us with your comments about this document.

To: Technical Publications Manager  
RE: Reader Response  
Total Pages Sent \_\_\_\_\_

From: Name \_\_\_\_\_  
Company \_\_\_\_\_  
Address \_\_\_\_\_  
City / State / ZIP / Country \_\_\_\_\_  
Telephone: (\_\_\_\_\_) \_\_\_\_\_ - \_\_\_\_\_ FAX: (\_\_\_\_\_) \_\_\_\_\_ - \_\_\_\_\_

Application (optional):

Would you like a reply? \_\_\_Y \_\_\_N

Device: PIC12F519

Literature Number: DS41319B

Questions:

1. What are the best features of this document?

---

---

2. How does this document meet your hardware and software development needs?

---

---

3. Do you find the organization of this document easy to follow? If not, why?

---

---

4. What additions to the document do you think would enhance the structure and subject?

---

---

5. What deletions from the document could be made without affecting the overall usefulness?

---

---

6. Is there any incorrect or misleading information (what and where)?

---

---

7. How would you improve this document?

---

---

## PRODUCT IDENTIFICATION SYSTEM

To order or obtain information, e.g., on pricing or delivery, refer to the factory or the listed sales office.

<u>PART NO.</u>	<u>X</u>	<u>XX</u>	<u>XXX</u>
Device	Temperature Range	Package	Pattern
<b>Device:</b> PIC12F519 PIC12F519T (Tape and Reel)	<b>Temperature Range:</b> I = -40°C to +85°C (Industrial) E = -40°C to +125°C (Extended)	<b>Package:</b> MC = 8L DFN 2x3 (DUAL Flatpack No-Leads) MS = MSOP (Pb-free) P = 300 mil PDIP (Pb-free) SN = 3.90 mm SOIC, 8-LD (Pb-free)	<b>Pattern:</b> Special Requirements
<b>Note:</b> Tape and Reel available for only the following packages: SOIC, DFN and MSOP.			

**Examples:**

- a) PIC12F519-I/P = Industrial temp., PDIP package (Pb-free)
- b) PIC12F519T-I/SN = Tape and Reel, Industrial temp., SOIC package
- c) PIC12F519 - E/MS 303 = Extended temp., MSOP package, QTP pattern #303



## WORLDWIDE SALES AND SERVICE

### AMERICAS

**Corporate Office**  
2355 West Chandler Blvd.  
Chandler, AZ 85224-6199  
Tel: 480-792-7200  
Fax: 480-792-7277  
Technical Support:  
<http://support.microchip.com>  
Web Address:  
[www.microchip.com](http://www.microchip.com)

**Atlanta**  
Duluth, GA  
Tel: 678-957-9614  
Fax: 678-957-1455

**Boston**  
Westborough, MA  
Tel: 774-760-0087  
Fax: 774-760-0088

**Chicago**  
Itasca, IL  
Tel: 630-285-0071  
Fax: 630-285-0075

**Dallas**  
Addison, TX  
Tel: 972-818-7423  
Fax: 972-818-2924

**Detroit**  
Farmington Hills, MI  
Tel: 248-538-2250  
Fax: 248-538-2260

**Kokomo**  
Kokomo, IN  
Tel: 765-864-8360  
Fax: 765-864-8387

**Los Angeles**  
Mission Viejo, CA  
Tel: 949-462-9523  
Fax: 949-462-9608

**Santa Clara**  
Santa Clara, CA  
Tel: 408-961-6444  
Fax: 408-961-6445

**Toronto**  
Mississauga, Ontario,  
Canada  
Tel: 905-673-0699  
Fax: 905-673-6509

### ASIA/PACIFIC

**Asia Pacific Office**  
Suites 3707-14, 37th Floor  
Tower 6, The Gateway  
Harbour City, Kowloon  
Hong Kong  
Tel: 852-2401-1200  
Fax: 852-2401-3431

**Australia - Sydney**  
Tel: 61-2-9868-6733  
Fax: 61-2-9868-6755

**China - Beijing**  
Tel: 86-10-8528-2100  
Fax: 86-10-8528-2104

**China - Chengdu**  
Tel: 86-28-8665-5511  
Fax: 86-28-8665-7889

**China - Hong Kong SAR**  
Tel: 852-2401-1200  
Fax: 852-2401-3431

**China - Nanjing**  
Tel: 86-25-8473-2460  
Fax: 86-25-8473-2470

**China - Qingdao**  
Tel: 86-532-8502-7355  
Fax: 86-532-8502-7205

**China - Shanghai**  
Tel: 86-21-5407-5533  
Fax: 86-21-5407-5066

**China - Shenyang**  
Tel: 86-24-2334-2829  
Fax: 86-24-2334-2393

**China - Shenzhen**  
Tel: 86-755-8203-2660  
Fax: 86-755-8203-1760

**China - Wuhan**  
Tel: 86-27-5980-5300  
Fax: 86-27-5980-5118

**China - Xiamen**  
Tel: 86-592-2388138  
Fax: 86-592-2388130

**China - Xian**  
Tel: 86-29-8833-7252  
Fax: 86-29-8833-7256

**China - Zhuhai**  
Tel: 86-756-3210040  
Fax: 86-756-3210049

### ASIA/PACIFIC

**India - Bangalore**  
Tel: 91-80-4182-8400  
Fax: 91-80-4182-8422

**India - New Delhi**  
Tel: 91-11-4160-8631  
Fax: 91-11-4160-8632

**India - Pune**  
Tel: 91-20-2566-1512  
Fax: 91-20-2566-1513

**Japan - Yokohama**  
Tel: 81-45-471- 6166  
Fax: 81-45-471-6122

**Korea - Daegu**  
Tel: 82-53-744-4301  
Fax: 82-53-744-4302

**Korea - Seoul**  
Tel: 82-2-554-7200  
Fax: 82-2-558-5932 or  
82-2-558-5934

**Malaysia - Kuala Lumpur**  
Tel: 60-3-6201-9857  
Fax: 60-3-6201-9859

**Malaysia - Penang**  
Tel: 60-4-227-8870  
Fax: 60-4-227-4068

**Philippines - Manila**  
Tel: 63-2-634-9065  
Fax: 63-2-634-9069

**Singapore**  
Tel: 65-6334-8870  
Fax: 65-6334-8850

**Taiwan - Hsin Chu**  
Tel: 886-3-572-9526  
Fax: 886-3-572-6459

**Taiwan - Kaohsiung**  
Tel: 886-7-536-4818  
Fax: 886-7-536-4803

**Taiwan - Taipei**  
Tel: 886-2-2500-6610  
Fax: 886-2-2508-0102

**Thailand - Bangkok**  
Tel: 66-2-694-1351  
Fax: 66-2-694-1350

### EUROPE

**Austria - Wels**  
Tel: 43-7242-2244-39  
Fax: 43-7242-2244-393

**Denmark - Copenhagen**  
Tel: 45-4450-2828  
Fax: 45-4485-2829

**France - Paris**  
Tel: 33-1-69-53-63-20  
Fax: 33-1-69-30-90-79

**Germany - Munich**  
Tel: 49-89-627-144-0  
Fax: 49-89-627-144-44

**Italy - Milan**  
Tel: 39-0331-742611  
Fax: 39-0331-466781

**Netherlands - Drunen**  
Tel: 31-416-690399  
Fax: 31-416-690340

**Spain - Madrid**  
Tel: 34-91-708-08-90  
Fax: 34-91-708-08-91

**UK - Wokingham**  
Tel: 44-118-921-5869  
Fax: 44-118-921-5820



## X-ON Electronics

Largest Supplier of Electrical and Electronic Components

*Click to view similar products for [Microprocessors - MPU category](#):*

*Click to view products by [Microchip manufacturer](#):*

Other Similar products are found below :

[A2C00010998 A](#) [ALXD800EEXJCVD C3](#) [A2C00010729 A](#) [TS68040MF33A](#) [BOXSTCK1A8LFCL](#) [UPD78F0503AMCA-CAB-G](#)  
[Z8018008VEG](#) [LS1021ASN7KQB](#) [T2080NXE8PTB](#) [T2080NSE8PTB](#) [CM8063501521600S R19L](#) [T2080NXE8T1B](#) [FH8067303534005S](#)  
[R3ZM](#) [R9A07G044L24GBG#AC0](#) [HW8076502640002S R38F](#) [R7S721030VLFP#AA0](#) [MCIMX6U5DVM10AC](#) [TEN54LSDV23GME](#)  
[MPC8314VRAGDA](#) [MPC8315VRAGDA](#) [PIC16F1828-I/SS](#) [PIC16F690T-I/SS](#) [PIC16F1823-I/SL](#) [NS7520B-1-I46](#) [AT91SAM9G35-CU](#)  
[AT91SAM9X25-CU](#) [ST7FLIT35F2DAKTR](#) [Z84C0006PEG](#) [AM1808EZWT4](#) [AT91SAM9G25-CFU](#) [GD32F303RCT6](#) [MPC5121YVY400B](#)  
[SMS3700HAX4DQE](#) [ADD4200IAA5DOE](#) [ST7PLITE05OBXTR](#) [AT91SAM9260B-CU-999](#) [AT91RM9200-CJ-002](#) [AT91RM9200-QU-002](#)  
[AT91SAM9260B-CU](#) [AT91SAM9CN12B-CFU](#) [AT91SAM9G20B-CFU](#) [AT91SAM9G20B-CU](#) [AT91SAM9G15-CU](#) [AT91SAM9X35-CU](#)  
[ATSAMA5D35A-CU](#) [MCIMX6Q5EYM10AD](#) [ALXC700EETH2VD C3](#) [AM1707DZKB4](#) [SC91F729BD14U](#) [STC15W408AS-35I-DIP16](#)