

## PIC18-Q84 Family Product Brief

### Introduction

The PIC18-Q84 microcontroller family is available in 28/40/44/48-pin devices for many automotive and industrial applications. The many communication peripherals found on the product family, such as CAN, SPI, I<sup>2</sup>C, two UARTs, can handle a wide range of wired and wireless (using external modules) communication protocols for intelligent applications. This, combined with the Core Independent Peripherals integration capabilities, enable functions for motor control, power supply, sensor, signal and user interface applications. Additionally, this family includes a 12-bit ADC with Computation and Context Switching extensions for automated signal analysis to reduce the complexity of the application.

### PIC18-Q84 Family Types

Table 1. Devices Included in This Data Sheet

Device	Program Memory Flash (bytes)	Data SRAM (bytes)	Data EEPROM (bytes)	Memory Access Partition/ Device Information Area	I/O Pins/ Peripheral Pin Select	8-Bit Timer with HLT/ 16-Bit Timers	16-Bit Dual PWM/ CCP	Complimentary Waveform Generator	Signal Measurement Timer	16-Bit Universal Timer	Numerically Controlled Oscillator	Configurable Logic Cell	12-Bit ADC w/Computation and Context Switching (channels)	8-Bit DAC	Comparator/ Zero-Cross Detect	High-Low Voltage Detect	CAN FD	SPI/I <sup>2</sup> C	UART/ UART with Protocol Support	Direct Memory Access (DMA)	Windowed Watchdog Timer	32-Bit CRC with Scanner	Vectored Interrupts	Peripheral Module Disable	Temperature Indicator
PIC18F26Q84	64k	8192	1024	Y/Y	25/Y	3/3	4/3	3	1	2	3	8	24	1	2/1	1	Y	2/1	3/2	8	Y	Y	Y	Y	Y
PIC18F27Q84	128k	12800	1024	Y/Y	25/Y	3/3	4/3	3	1	2	3	8	24	1	2/1	1	Y	2/1	3/2	8	Y	Y	Y	Y	Y
PIC18F46Q84	64k	8192	1024	Y/Y	36/Y	3/3	4/3	3	1	2	3	8	24	1	2/1	1	Y	2/1	3/2	8	Y	Y	Y	Y	Y
PIC18F47Q84	128k	12800	1024	Y/Y	36/Y	3/3	4/3	3	1	2	3	8	24	1	2/1	1	Y	2/1	3/2	8	Y	Y	Y	Y	Y
PIC18F56Q84	64k	8192	1024	Y/Y	44/Y	3/3	4/3	3	1	2	3	8	35	1	2/1	1	Y	2/1	3/2	8	Y	Y	Y	Y	Y
PIC18F57Q84	128k	12800	1024	Y/Y	44/Y	3/3	4/3	3	1	2	3	8	35	1	2/1	1	Y	2/1	3/2	8	Y	Y	Y	Y	Y

### Features

- C Compiler Optimized RISC Architecture
- Operating Speed:
  - DC – 64 MHz clock input
  - 62.5 ns minimum instruction cycle
- Eight Direct Memory Access (DMA) Controllers:

- Data transfers to SFR/GPR spaces from either Program Flash Memory, Data EEPROM or SFR/GPR spaces
- User programmable source and destination sizes
- Hardware and software triggered data transfers
- Vectored Interrupt Capability:
  - Selectable high/low priority
  - Fixed interrupt latency of three instruction cycles
  - Programmable vector table base address
  - Backwards compatible with previous interrupt capabilities
- 128-Level Deep Hardware Stack
- Low-Current Power-on Reset (POR)
- Configurable Power-up Timer (PWRT)
- Brown-out Reset (BOR)
- Low-Power BOR (LPBOR) Option
- Windowed Watchdog Timer (WWDT):
  - Watchdog Reset on too long or too short interval between watchdog clear events
  - Variable prescaler selection
  - Variable window size selection

## Memory

---

- Up to 128 KB of Program Flash Memory
- Up to 13 KB of Data SRAM Memory
- 1024 Bytes Data EEPROM
- Memory Access Partition: The Program Flash Memory can be partitioned into:
  - Application Block
  - Boot Block
  - Storage Area Flash (SAF) Block
- Programmable Code Protection and Write Protection
- Device Information Area (DIA) Stores:
  - Temperature indicator factory calibrated data
  - Fixed Voltage Reference measurement data
  - Microchip unique identifier
- Device Characteristics Information (DCI) Area Stores:
  - Program/erase row sizes
  - Pin count details
  - EEPROM size
- Direct, Indirect and Relative Addressing modes

## Operating Characteristics

---

- Operating Voltage Range:
  - 1.8V to 5.5V
- Temperature Range:
  - Industrial: -40°C to 85°C
  - Extended: -40°C to 125°C

---

## Power-Saving Functionality

---

- Doze: CPU and Peripherals Running at Different Cycle Rates (typically CPU is lower)
- Idle: CPU Halted While Peripherals Operate
- Sleep: Lowest Power Consumption
- Peripheral Module Disable (PMD):
  - Ability to selectively disable hardware module to minimize active power consumption of unused peripherals
- Low-Power Mode Features:
  - Sleep: < 1 $\mu$ A typical @ 3V
  - Operating Current:
    - 48 $\mu$ A @ 32 kHz, 3V, typical

---

## Digital Peripherals

---

- Four 16-Bit Pulse-Width Modulators (PWM):
  - Dual outputs for each PWM module
  - Integrated 16-bit timer/counter
  - Double-buffered user registers for duty cycles
  - Right/Left/Center/Variable aligned modes of operation
  - Multiple clock and Reset signal selections
- Three 16-Bit Timers (TMR0/1/3)
- Three 8-Bit Timers (TMR2/4/6) with Hardware Limit Timer (HLT)
- Two Universal Timers (TMRU16A/16B):
  - New Timer modules with features of TMR0/TMR1/TMR2 (Gate, Hardware Limit)
  - Two 16-bit timers can be chained together to create a combined 32-bit timer
- Eight Configurable Logic Cell (CLC):
  - Integrated combinational and sequential logic
- Three Complimentary Waveform Generators (CWG):
  - Rising and falling edge dead-band control
  - Full-bridge, half-bridge, 1-channel drive
  - Multiple signal sources
  - Programmable dead band
  - Fault-shutdown input
- Three Capture/Compare/PWM (CCP) modules:
  - 16-bit resolution for Capture/Compare modes
  - 10-bit resolution for PWM mode
- Three Numerically Controlled Oscillators (NCO):
  - Generates true linear frequency control and increased frequency resolution
  - Input clock up to 64 MHz
- Signal Measurement Timer (SMT):
  - 24-bit timer/counter with prescaler
  - Several modes of operation like Time-of-Flight, Period and Duty Cycle measurement, etc.
- Data Signal Modulator (DSM):
  - Multiplex two carrier clocks, with glitch prevention feature
  - Multiple sources for each carrier
- Programmable CRC with Memory Scan:
  - Reliable data/program memory monitoring for Fail-Safe operation (e.g., Class B)
  - Calculate 16-bit CRC over any portion of Program Flash Memory
- CAN Flexible Data-Rate (FD) module:

- Functional in CAN FD or CAN 2.0B modes
- One dedicated transmit FIFO
- Three Programmable Transmit/Receive FIFOs
- One Transmit Event Queue
- 12 Acceptance Masks/Filters
- Calculate 16-bit CRC over any portion of Program Flash Memory
- Five UART modules:
  - LIN master and slave, DMX mode, DALI gear and device protocols
  - Asynchronous UART, RS-232, RS-485 compatible
  - Automatic and user timed BREAK period generation
  - Automatic checksums
  - Programmable 1, 1.5, and two Stop bits
  - Wake-up on BREAK reception
  - DMA compatible
- Two SPI modules:
  - Configurable length bytes
  - Arbitrary length data packets
  - Transmit-without-receive and receive-without-transmit options
  - Transfer byte counter
  - Separate transmit and receive buffers with 2-byte FIFO and DMA capabilities
- One I<sup>2</sup>C module, SMBus, PMBus™ Compatible:
  - 7-bit and 10-bit addressing modes with address masking modes
  - Dedicated address, transmit and receive buffers and DMA capabilities
  - Bus collision detection with arbitration
  - Bus time-out detection and handling
  - I<sup>2</sup>C, SMBus 2.0 and SMBus 3.0, and 1.8V input level selections
  - Multi-Master mode, including self-addressing
- Device I/O Port Features:
  - 25 I/O pins (PIC18F26/27Q84)
  - 36 I/O pins (PIC18F46/47Q84)
  - 44 I/O pins (PIC18F56/57Q84)
  - Individually programmable I/O direction, open-drain, slew rate and weak pull-up control
  - Interrupt-on-change on most pins
  - Three programmable external interrupt pins
- Peripheral Pin Select (PPS):
  - Enables pin mapping of digital I/O

## Analog Peripherals

---

- Analog-to-Digital Converter with Computation and Context Saving:
  - Up to 43 external channels
  - Automated math functions on input signals:
    - Averaging, filter calculations, oversampling and threshold comparison
  - 4 Separate Contexts (settings and results) saved and accessible separately
  - Contexts can be accessed through firmware or DMA
  - Operates in Sleep
  - Five internal analog channels
  - Hardware Capacitive Voltage Divider (CVD) Support:
    - Adjustable sample and hold capacitor array

- Guard ring digital output drive
- Automates touch sampling and reduces software size and CPU usage when touch or proximity sensing is required
- 8-Bit Digital-to-Analog Converter (DAC):
  - Buffered output available on two I/O pins
  - Internal connections to ADC and Comparators
- Two Comparators (CMP):
  - Four external inputs
  - Configurable output polarity
  - External output via Peripheral Pin Select
- Zero-Cross Detect (ZCD):
  - Detect when AC signal on pin crosses ground
- Voltage Reference:
  - Fixed Voltage Reference with 1.024V, 2.048V and 4.096V output levels
  - Internal connections to ADC, Comparator and DAC

## Clocking Structure

---

- High-Precision Internal Oscillator Block (HFINTOSC):
  - Selectable frequencies up to 64 MHz
  - $\pm 1\%$  at calibration
  - Active Clock Tuning of HFINTOSC for better accuracy
- 32 kHz Low-Power Internal Oscillator (LFINTOSC)
- External 32 kHz Crystal Oscillator (SOSC)
- External High-frequency Oscillator Block:
  - Three crystal/resonator modes
  - Digital Clock Input mode
  - 4x PLL with external sources
- Fail-Safe Clock Monitor:
  - Allows for operational recovery if external clock stops
- Oscillator Start-up Timer (OST):
  - Ensures stability of crystal oscillator sources

## Programming/Debug Features

---

- In-Circuit Serial Programming™ (ICSP™) via Two Pins
- In-Circuit Debug (ICD) with Three Breakpoints via Two Pins
- Debug Integrated On-Chip

---

## **Table of Contents**

---

Introduction.....	1
PIC18-Q84 Family Types.....	1
Features.....	1
Memory.....	2
Operating Characteristics.....	2
Power-Saving Functionality.....	3
Digital Peripherals.....	3
Analog Peripherals.....	4
Clocking Structure.....	5
Programming/Debug Features.....	5
1. Packages.....	7
2. Pin Diagrams.....	8
3. Pin Allocation Tables.....	13
The Microchip Website.....	18
Product Change Notification Service.....	18
Customer Support.....	18
Microchip Devices Code Protection Feature.....	18
Legal Notice.....	18
Trademarks.....	19
Quality Management System.....	19
Worldwide Sales and Service.....	20

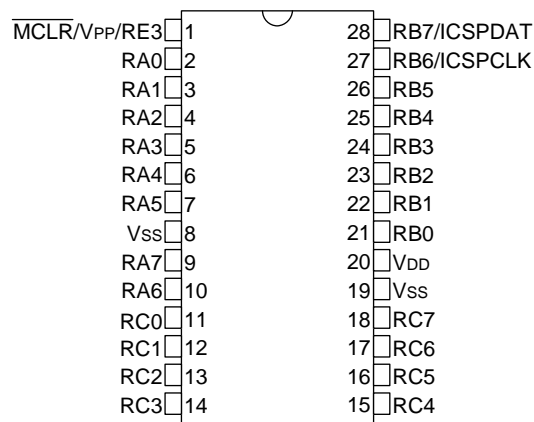
## 1. Packages

**Table 1-1. Packages**

Device	28-Pin SPDIP	28-Pin SOIC	28-Pin SSOP	28-Pin VQFN 6x6x1	40-Pin PDIP	40-Pin VQFN 5x5x0.9	44-Pin TQFP	48-Pin TQFP 7x7x1	48-Pin VQFN 6x6x0.9
PIC18F26Q84	•	•	•	•					
PIC18F27Q84	•	•	•	•					
PIC18F46Q84					•	•	•		
PIC18F47Q84					•	•	•		
PIC18F56Q84								•	•
PIC18F57Q84								•	•

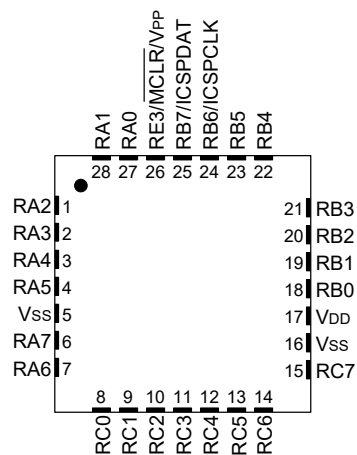
## 2. Pin Diagrams

Figure 2-1. 28-Pin SPDIP, SSOP, SOIC



Rev. 00-000028A  
10/2016

Figure 2-2. 28-Pin , VQFN

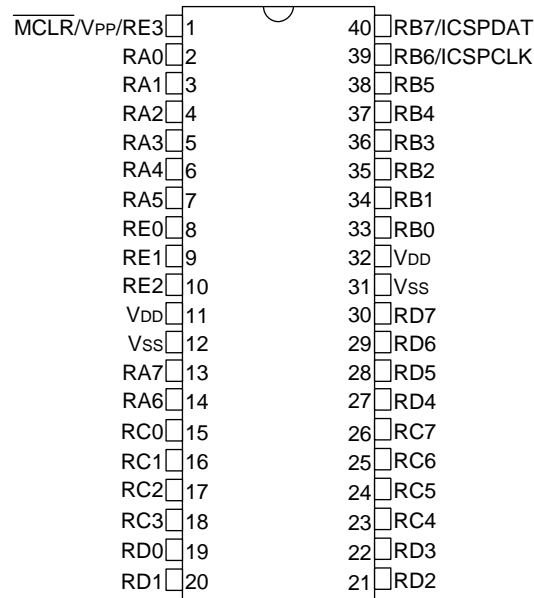


Rev. 00-000028B  
6/23/2017

**Note:** It is recommended that the exposed bottom pad be connected to V<sub>SS</sub>, however it must not be the only V<sub>SS</sub> connection to the device.

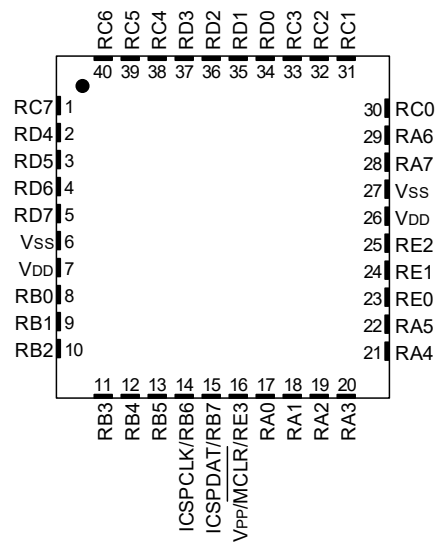


Figure 2-3. 40-Pin PDIP



Rev. 00-00040A  
10/3/2018

Figure 2-4. 40-Pin, VQFN



Rev. 00-00040B  
11/6/2017

**Note:** It is recommended that the exposed bottom pad be connected to  $V_{SS}$ , however it must not be the only  $V_{SS}$  connection to the device.

Figure 2-5. 44-Pin TQFP

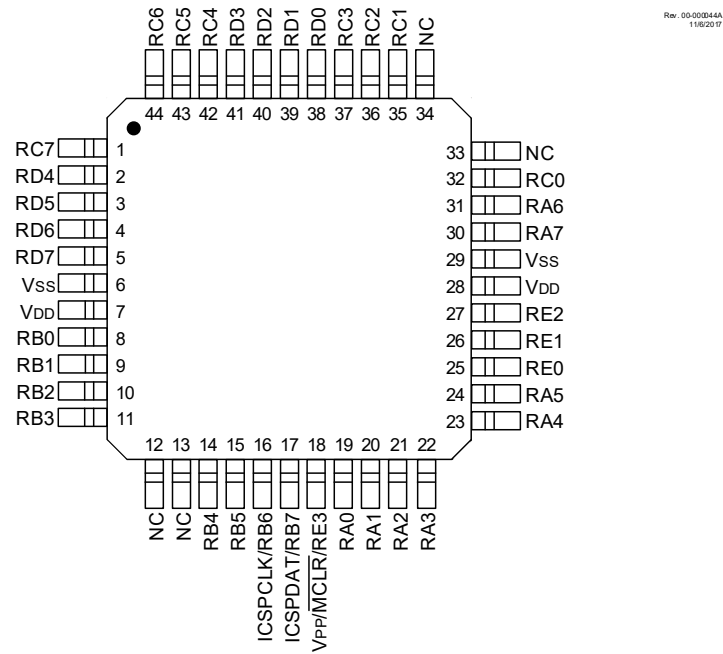


Figure 2-6. 48-Pin TQFP

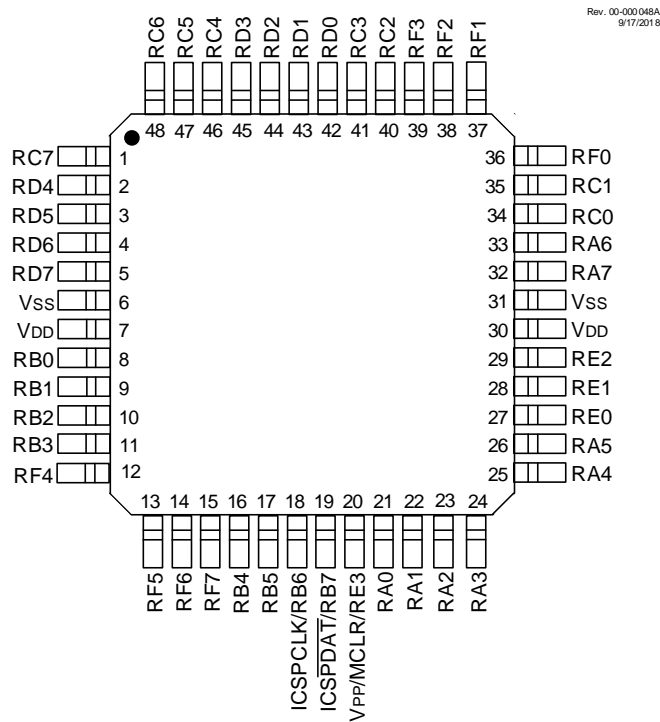


Figure 2-7. 48-Pin VQFN

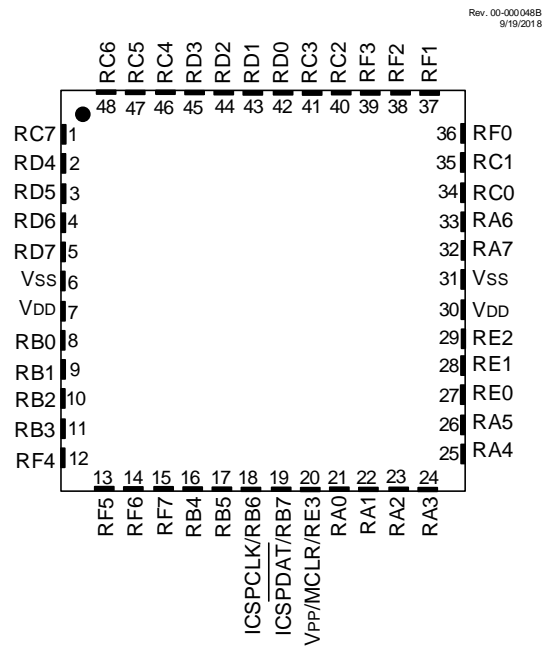


Figure 2-8. 64-Pin TQFP

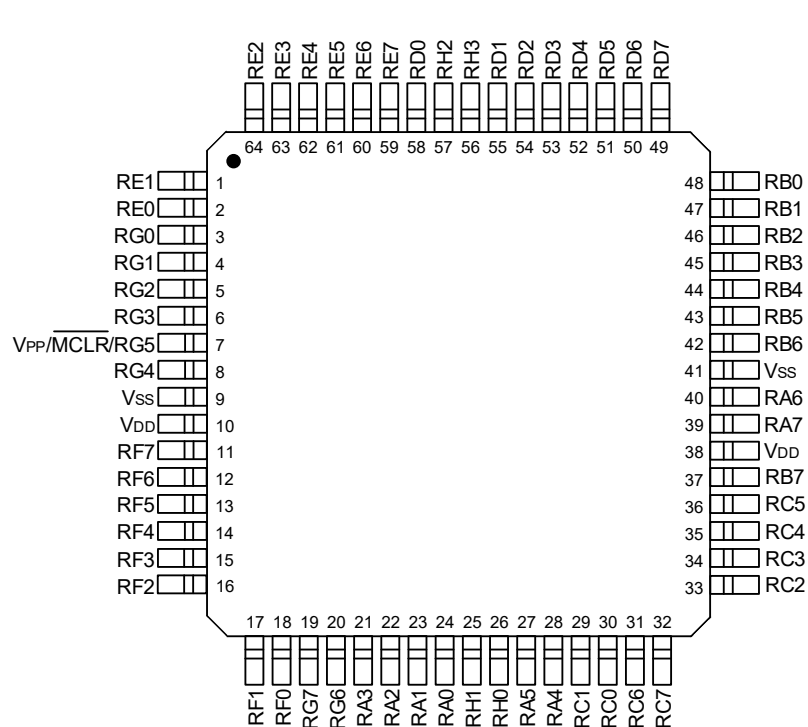
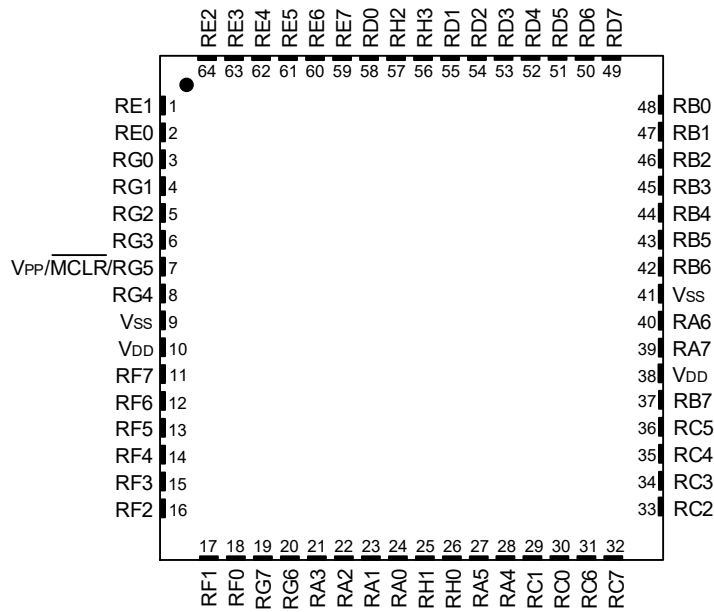


Figure 2-9. 64-Pin QFN

Rev. 00-000664B  
3/12/17



**Note:** It is recommended that the exposed bottom pad be connected to V<sub>SS</sub>, however it must not be the only V<sub>SS</sub> connection to the device.

Table 3-1. 28-Pin Allocation Table

I/O(2)	28-Pin SPDIP, SOIC, SSOP	28-Pin VQFN	A/D	Reference	Comparator	ZCD	Timers/SMT	16-Bit PWM/ CCP	CWG	CLC	SPI	I <sup>2</sup> C	UART	DSM	IOC	Interrupt	CAN FD	CRC
RA0	2	27	ANA0	—	C1IN0- C2IN0-	—	—	—	—	CLCIN0(1) CLCIN4(1)	—	—	—	—	IOCA0	—	—	—
RA1	3	28	ANA1	—	C1IN1- C2IN1-	—	—	—	—	CLCIN1(1) CLCIN5(1)	—	—	—	—	IOCA1	—	—	—
RA2	4	1	ANA2	DAC1OUT1 VREF- (DAC) VREF- (ADC)	C1IN0+ C2IN0+	—	—	—	—	—	—	—	—	—	IOCA2	—	—	BO
RA3	5	2	ANA3	VREF+ (DAC) VREF+ (ADC)	C1IN1+	—	—	—	—	—	—	—	—	MDCARL(1)	IOCA3	—	—	—
RA4	6	3	ANA4	—	—	—	TOCKI(1)	—	—	—	SS2(1)	—	CTS5(1)	MDCARH(1)	IOCA4	—	—	BO
RA5	7	4	ANA5	—	—	—	—	—	—	—	SS1(1)	—	RX5(1)	MDSRC(1)	IOCA5	—	—	—
RA6	10	7	ANA6	—	—	—	—	—	—	—	—	—	CTS3(1)	—	IOCA6	—	—	—
RA7	9	6	ANA7	—	—	—	—	—	—	—	—	—	RX3(1)	—	IOCA7	—	—	—
RB0	21	18	ANB0	—	C2IN1+	ZCDIN	—	—	CWG1(1)	—	—	—	—	—	IOCB0	INT0(1)	—	—
RB1	22	19	ANB1	—	C1IN3- C2IN3-	—	—	—	CWG2(1)	—	—	—(4)	—	—	IOCB1	INT1(1)	—	—
RB2	23	20	ANB2	—	—	—	—	—	CWG3(1)	—	SDI2(1)	—(4)	—	—	IOCB2	INT2(1)	—	—
RB3	24	21	ANB3	—	C1IN2- C2IN2-	—	—	—	—	—	SCK2(1)	—	—	—	IOCB3	—	CANRX(1)	—
RB4	25	22	ANB4 ADACT(1)	—	—	—	T5G(1)	—	—	—	—	—	CTS4(1)	—	IOCB4	—	—	—
RB5	26	23	ANB5	—	—	—	T1G(1)	CCP3(1)	—	—	—	—	RX4(1)	—	IOCB5	—	—	—
RB6	27	24	ANB6	—	—	—	—	—	—	CLCIN2(1) CLCIN6(1)	—	—	CTS2(1)	—	IOCB6	—	—	—
RB7	28	25	ANB7	DAC1OUT2	—	—	T6IN(1)	PWM3ERS(1)	—	CLCIN3(1) CLCIN7(1)	—	—	RX2(1)	—	IOCB7	—	—	—
RC0	11	8	ANC0	—	—	—	T1CKI(1) T3CKI(1) T3G(1) SMT1WIN(1)	—	—	—	—	—	—	—	IOCC0	—	—	—
RC1	12	9	ANC1	—	—	—	SMT1SIG(1)	CCP2(1)	—	—	—	—	—	—	IOCC1	—	—	—

.....continued																			
I/O <sup>(2)</sup>	28-Pin SPDIP, SOIC, SSOP	28-Pin VQFN	A/D	Reference	Comparator	ZCD	Timers/SMT	16-Bit PWM/ CCP	CWG	CLC	SPI	I <sup>2</sup> C	UART	DSM	IOC	Interrupt	CAN FD	CRC	
RC2	13	10	ANC2	—	—	—	T5CKI <sup>(1)</sup>	PWMIN0 <sup>(1)</sup> CCP1 <sup>(1)</sup>	—	—	—	—	—	—	IOCC2	—	—		
RC3	14	11	ANC3	—	—	—	T2IN <sup>(1)</sup>	PWM1ERS <sup>(1)</sup>	—	—	SCK1 <sup>(1)</sup>	SCL1 <sup>(3,4)</sup>	—	—	IOCC3	—	—		
RC4	15	12	ANC4	—	—	—	—	—	—	—	SDI1 <sup>(1)</sup>	SDA <sup>(3,4)</sup>	—	—	IOCC4	—	—		BO
RC5	16	13	ANC5	—	—	—	T4IN <sup>(1)</sup>	PWM2ERS <sup>(1)</sup>	—	—	—	—	—	—	IOCC5	—	—		BO
RC6	17	14	ANC6	—	—	—	—	PWMIN1 <sup>(1)</sup>	—	—	—	—	CTS1 <sup>(1)</sup>	—	IOCC6	—	—		
RC7	18	15	ANC7	—	—	—	—	—	—	—	—	—	RX1 <sup>(1)</sup>	—	IOCC7	—	—		
RE3	1	26	—	—	—	—	—	—	—	—	—	—	—	—	IOCE3	—	—		
VSS	19	16	—	—	—	—	—	—	—	—	—	—	—	—	—	—	—		
VDD <sup>(5)</sup>	20	17	—	—	—	—	—	—	—	—	—	—	—	—	—	—	—		
VSS	8	5	—	—	—	—	—	—	—	—	—	—	—	—	—	—	—		
OUT <sup>(2)</sup>	—	—	ADGRDA ADGRDB	—	C1OUT C2OUT	—	TMR0	PWM11 PWM12 PWM21 PWM22 PWM31 PWM32 CCP1 CCP2 CCP3 CWG1A CWG1B CWG1C CWG1D CWG2A CWG2B CWG2C CWG2D CWG3A CWG3B CWG3C CWG3D	CLC1OUT CLC2OUT CLC3OUT CLC4OUT CLC5OUT CLC6OUT CLC7OUT CLC8OUT	SS1 SCK1 SDO1 SS2 SCK2 SDO2	SDA1 SCL1	DTR1 RTS1 TX1 DTR2 RTS2 TX2 DTR3 RTS3 TX3 DTR4 RTS4 TX4 DTR5 RTS5 TX5	DSM1	—	—	CANTX			

**Note:**

1. This is a PPS remappable input signal. The input function may be moved from the default location shown to one of several other PORTx pins. Refer to the peripheral input selection table for details on which PORT pin.
2. All output signals shown in this row are PPS remappable. These signals may be mapped to output onto one of several PORTx pin options as described in the peripheral output selection table.
3. This is a bidirectional signal. For normal module operation, the firmware should map this signal to the same pin in both the PPS input and PPS output registers.
4. These pins are configured for I<sup>2</sup>C logic levels; The SCLx/SDAx signals may be assigned to any of these pins. PPS assignments to the other pins (e.g., RB1) will operate, but input logic levels will be standard TTL/ST.
5. A 0.1 uF bypass capacitor to VSS is required on the VDD pin.

Table 3-2. 40/44/48-Pin Allocation Table

I/O(2)	40-Pin PDIP	40-Pin VQFN	44-Pin TQFP	48-Pin TQFP / VQFN	A/D	Reference	Comparator	ZCD	Timers/SMT	16-Bit PWM/ CCP	CWG	CLC	SPI	I <sup>2</sup> C	UART	DSM	IOC	Interrupt
RA0	2	17	19	21	ANA0	—	C1IN0- C2IN0-	—	—	—	—	CLCIN0 <sup>(1)</sup> CLCIN4 <sup>(1)</sup>	—	—	—	—	IOCA0	—
RA1	3	18	20	22	ANA1	—	C1IN1- C2IN1-	—	—	—	—	CLCIN1 <sup>(1)</sup> CLCIN5 <sup>(1)</sup>	—	—	—	—	IOCA1	—
RA2	4	19	21	23	ANA2	DAC1OUT1 VREF- (DAC) VREF- (ADC)	C1IN0+ C2IN0+	—	—	—	—	—	—	—	—	—	IOCA2	—
RA3	5	20	22	24	ANA3	VREF+ (DAC) VREF+ (ADC)	C1IN1+	—	—	—	—	—	—	—	—	MDCARL <sup>(1)</sup>	IOCA3	—
RA4	6	21	23	25	ANA4	—	—	—	TOCKI <sup>(1)</sup>	—	—	—	SS2 <sup>(1)</sup>	—	CTS5 <sup>(1)</sup>	MDCARH <sup>(1)</sup>	IOCA4	—
RA5	7	22	24	26	ANA5	—	—	—	—	—	—	—	SS1 <sup>(1)</sup>	—	RX5 <sup>(1)</sup>	MDSRC <sup>(1)</sup>	IOCA5	—
RA6	14	29	31	33	ANA6	—	—	—	—	—	—	—	—	—	CTS3 <sup>(1)</sup>	—	IOCA6	—
RA7	13	28	30	32	ANA7	—	—	—	—	—	—	—	—	—	RX3 <sup>(1)</sup>	—	IOCA7	—
RB0	33	8	8	8	ANB0	—	C2IN1+	ZCDIN	—	—	CWG1 <sup>(1)</sup>	—	—	—	—	—	IOCB0	INT0
RB1	34	9	9	9	ANB1	—	C1IN3- C2IN3-	—	—	—	CWG2 <sup>(1)</sup>	—	—	— <sup>(4)</sup>	—	—	IOCB1	INT1
RB2	35	10	10	10	ANB2	—	—	—	—	—	CWG3 <sup>(1)</sup>	—	SDI2 <sup>(1)</sup>	— <sup>(4)</sup>	—	—	IOCB2	INT2
RB3	36	11	11	11	ANB3	—	C1IN2- C2IN2-	—	—	—	—	—	SCK2 <sup>(1)</sup>	—	—	—	IOCB3	—
RB4	37	12	14	16	ANB4 ADACT <sup>(1)</sup>	—	—	—	T5G <sup>(1)</sup>	—	—	—	—	—	CTS4 <sup>(1)</sup>	—	IOCB4	—
RB5	38	13	15	17	ANB5	—	—	—	T1G <sup>(1)</sup>	CCP3 <sup>(1)</sup>	—	—	—	—	RX4 <sup>(1)</sup>	—	IOCB5	—
RB6	39	14	16	18	ANB6	—	—	—	—	—	—	CLCIN2 <sup>(1)</sup> CLCIN6 <sup>(1)</sup>	—	—	CTS2 <sup>(1)</sup>	—	IOCB6	—





.....continued																		
I/O(2)	40- Pin PDIP	40- Pin VQFN	44- Pin TQFP	48- Pin TQFP / VQFN	A/D	Reference	Comparator	ZCD	Timers/SMT	16-Bit PWM/ CCP	CWG	CLC	SPI	I <sup>2</sup> C	UART	DSM	IOC	Interru
RF6	—	—	—	14	ANF6	—	—	—	—	—	—	—	—	—	—	—	—	—
RF7	—	—	—	15	ANF7	—	—	—	—	—	—	—	—	—	—	—	—	—
VSS	12, 31	6, 27	6, 29	6,31	—	—	—	—	—	—	—	—	—	—	—	—	—	—
VDD <sup>(5)</sup>	11, 32	7, 26	7, 28	7, 30	—	—	—	—	—	—	—	—	—	—	—	—	—	—
OUT <sup>(2)</sup>					ADGRDA ADGRDB	—	C1OUT C2OUT	—	TMR0	PWM11 PWM12 PWM21 PWM22 PWM31 PWM32 CCP1 CCP2 CCP3	CWG1A CWG1B CWG1C CWG1D CWG2A CWG2B CWG2C CWG3A CWG3B CWG3C CWG3D	CLC1OUT CLC2OUT CLC3OUT CLC4OUT CLC5OUT CLC6OUT CLC7OUT CLC8OUT	SS1 SCK1 SDO1 SS2 SCK2 SDO2	SDA1 SCL1	DTR1 RTS1 TX1 DTR2 RTS2 TX2 DTR3 RTS3 TX3 DTR4 RTS4 TX4 DTR5 RTS5 TX5	DSM1	—	—

**Note:**

1. This is a PPS remappable input signal. The input function may be moved from the default location shown to one of several other PORTx pins. Refer to the peripheral input selection table for more information. This signal may be used for this signal.
2. All output signals shown in this row are PPS remappable. These signals may be mapped to output onto one of several PORTx pin options as described in the peripheral output selection table for more information.
3. This is a bidirectional signal. For normal module operation, the firmware should map this signal to the same pin in both the PPS input and PPS output registers.
4. These pins are configured for I<sup>2</sup>C logic levels; The SCLx/SDAx signals may be assigned to any of these pins. PPS assignments to the other pins (e.g., RB1) will operate, but input logic levels will be selected by the INLVL register, instead of the I<sup>2</sup>C specific or SMBus input buffer thresholds.
5. A 0.1 uF bypass capacitor to VSS is required on all VDD pins.

---

## The Microchip Website

---

Microchip provides online support via our website at <http://www.microchip.com/>. This website is used to make files and information easily available to customers. Some of the content available includes:

- **Product Support** – Data sheets and errata, application notes and sample programs, design resources, user's guides and hardware support documents, latest software releases and archived software
- **General Technical Support** – Frequently Asked Questions (FAQs), technical support requests, online discussion groups, Microchip design partner program member listing
- **Business of Microchip** – Product selector and ordering guides, latest Microchip press releases, listing of seminars and events, listings of Microchip sales offices, distributors and factory representatives

---

## Product Change Notification Service

---

Microchip's product change notification service helps keep customers current on Microchip products. Subscribers will receive email notification whenever there are changes, updates, revisions or errata related to a specified product family or development tool of interest.

To register, go to <http://www.microchip.com/pcn> and follow the registration instructions.

---

## Customer Support

---

Users of Microchip products can receive assistance through several channels:

- Distributor or Representative
- Local Sales Office
- Embedded Solutions Engineer (ESE)
- Technical Support

Customers should contact their distributor, representative or ESE for support. Local sales offices are also available to help customers. A listing of sales offices and locations is included in this document.

Technical support is available through the website at: <http://www.microchip.com/support>

---

## Microchip Devices Code Protection Feature

---

Note the following details of the code protection feature on Microchip devices:

- Microchip products meet the specification contained in their particular Microchip Data Sheet.
- Microchip believes that its family of products is one of the most secure families of its kind on the market today, when used in the intended manner and under normal conditions.
- There are dishonest and possibly illegal methods used to breach the code protection feature. All of these methods, to our knowledge, require using the Microchip products in a manner outside the operating specifications contained in Microchip's Data Sheets. Most likely, the person doing so is engaged in theft of intellectual property.
- Microchip is willing to work with the customer who is concerned about the integrity of their code.
- Neither Microchip nor any other semiconductor manufacturer can guarantee the security of their code. Code protection does not mean that we are guaranteeing the product as "unbreakable."

Code protection is constantly evolving. We at Microchip are committed to continuously improving the code protection features of our products. Attempts to break Microchip's code protection feature may be a violation of the Digital Millennium Copyright Act. If such acts allow unauthorized access to your software or other copyrighted work, you may have a right to sue for relief under that Act.

---

## Legal Notice

---

Information contained in this publication regarding device applications and the like is provided only for your convenience and may be superseded by updates. It is your responsibility to ensure that your application meets with

your specifications. MICROCHIP MAKES NO REPRESENTATIONS OR WARRANTIES OF ANY KIND WHETHER EXPRESS OR IMPLIED, WRITTEN OR ORAL, STATUTORY OR OTHERWISE, RELATED TO THE INFORMATION, INCLUDING BUT NOT LIMITED TO ITS CONDITION, QUALITY, PERFORMANCE, MERCHANTABILITY OR FITNESS FOR PURPOSE. Microchip disclaims all liability arising from this information and its use. Use of Microchip devices in life support and/or safety applications is entirely at the buyer's risk, and the buyer agrees to defend, indemnify and hold harmless Microchip from any and all damages, claims, suits, or expenses resulting from such use. No licenses are conveyed, implicitly or otherwise, under any Microchip intellectual property rights unless otherwise stated.

---

## **Trademarks**

---

The Microchip name and logo, the Microchip logo, Adaptec, AnyRate, AVR, AVR logo, AVR Freaks, BesTime, BitCloud, chipKIT, chipKIT logo, CryptoMemory, CryptoRF, dsPIC, FlashFlex, flexPWR, HELDO, IGLOO, JukeBlox, KeeLoq, Kleer, LANCheck, LinkMD, maXStylus, maXTouch, MediaLB, megaAVR, Microsemi, Microsemi logo, MOST, MOST logo, MPLAB, OptoLyzer, PackeTime, PIC, picoPower, PICSTART, PIC32 logo, PolarFire, Prochip Designer, QTouch, SAM-BA, SenGenuity, SpyNIC, SST, SST Logo, SuperFlash, Symmetricom, SyncServer, Tachyon, TempTrackr, TimeSource, tinyAVR, UNI/O, Vectron, and XMEGA are registered trademarks of Microchip Technology Incorporated in the U.S.A. and other countries.

APT, ClockWorks, The Embedded Control Solutions Company, EtherSynch, FlashTec, Hyper Speed Control, HyperLight Load, IntelliMOS, Libero, motorBench, mTouch, Powermite 3, Precision Edge, ProASIC, ProASIC Plus, ProASIC Plus logo, Quiet-Wire, SmartFusion, SyncWorld, Temux, TimeCesium, TimeHub, TimePictra, TimeProvider, Vite, WinPath, and ZL are registered trademarks of Microchip Technology Incorporated in the U.S.A.

Adjacent Key Suppression, AKS, Analog-for-the-Digital Age, Any Capacitor, AnyIn, AnyOut, BlueSky, BodyCom, CodeGuard, CryptoAuthentication, CryptoAutomotive, CryptoCompanion, CryptoController, dsPICDEM, dsPICDEM.net, Dynamic Average Matching, DAM, ECAN, EtherGREEN, In-Circuit Serial Programming, ICSP, INICnet, Inter-Chip Connectivity, JitterBlocker, KleerNet, KleerNet logo, memBrain, Mindi, MiWi, MPASM, MPF, MPLAB Certified logo, MPLIB, MPLINK, MultiTRAK, NetDetach, Omniscient Code Generation, PICDEM, PICDEM.net, PICkit, PICtail, PowerSmart, PureSilicon, QMatrix, REAL ICE, Ripple Blocker, SAM-ICE, Serial Quad I/O, SMART-I.S., SQI, SuperSwitcher, SuperSwitcher II, Total Endurance, TSHARC, USBCheck, VariSense, ViewSpan, WiperLock, Wireless DNA, and ZENA are trademarks of Microchip Technology Incorporated in the U.S.A. and other countries.

SQTP is a service mark of Microchip Technology Incorporated in the U.S.A.

The Adaptec logo, Frequency on Demand, Silicon Storage Technology, and Symmcom are registered trademarks of Microchip Technology Inc. in other countries.

GestIC is a registered trademark of Microchip Technology Germany II GmbH & Co. KG, a subsidiary of Microchip Technology Inc., in other countries.

All other trademarks mentioned herein are property of their respective companies.

© 2020, Microchip Technology Incorporated, Printed in the U.S.A., All Rights Reserved.

ISBN: 978-1-5224-5753-4

---

## **Quality Management System**

---

For information regarding Microchip's Quality Management Systems, please visit <http://www.microchip.com/quality>.

## Worldwide Sales and Service

AMERICAS	ASIA/PACIFIC	ASIA/PACIFIC	EUROPE
<p><b>Corporate Office</b> 2355 West Chandler Blvd. Chandler, AZ 85224-6199 Tel: 480-792-7200 Tel: 480-792-7277 Technical Support: <a href="http://www.microchip.com/support">http://www.microchip.com/support</a> Web Address: <a href="http://www.microchip.com">http://www.microchip.com</a></p> <p><b>Atlanta</b> Duluth, GA Tel: 678-957-9614 Fax: 678-957-1455</p> <p><b>Austin, TX</b> Tel: 512-257-3370</p> <p><b>Boston</b> Westborough, MA Tel: 774-760-0087 Fax: 774-760-0088</p> <p><b>Chicago</b> Itasca, IL Tel: 630-285-0071 Fax: 630-285-0075</p> <p><b>Dallas</b> Addison, TX Tel: 972-818-7423 Fax: 972-818-2924</p> <p><b>Detroit</b> Novi, MI Tel: 248-848-4000</p> <p><b>Houston, TX</b> Tel: 281-894-5983</p> <p><b>Indianapolis</b> Noblesville, IN Tel: 317-773-8323 Fax: 317-773-5453 Tel: 317-536-2380</p> <p><b>Los Angeles</b> Mission Viejo, CA Tel: 949-462-9523 Fax: 949-462-9608 Tel: 951-273-7800</p> <p><b>Raleigh, NC</b> Tel: 919-844-7510</p> <p><b>New York, NY</b> Tel: 631-435-6000</p> <p><b>San Jose, CA</b> Tel: 408-735-9110 Tel: 408-436-4270</p> <p><b>Canada - Toronto</b> Tel: 905-695-1980 Fax: 905-695-2078</p>	<p><b>Australia - Sydney</b> Tel: 61-2-9868-6733</p> <p><b>China - Beijing</b> Tel: 86-10-8569-7000</p> <p><b>China - Chengdu</b> Tel: 86-28-8665-5511</p> <p><b>China - Chongqing</b> Tel: 86-23-8980-9588</p> <p><b>China - Dongguan</b> Tel: 86-769-8702-9880</p> <p><b>China - Guangzhou</b> Tel: 86-20-8755-8029</p> <p><b>China - Hangzhou</b> Tel: 86-571-8792-8115</p> <p><b>China - Hong Kong SAR</b> Tel: 852-2943-5100</p> <p><b>China - Nanjing</b> Tel: 86-25-8473-2460</p> <p><b>China - Qingdao</b> Tel: 86-532-8502-7355</p> <p><b>China - Shanghai</b> Tel: 86-21-3326-8000</p> <p><b>China - Shenyang</b> Tel: 86-24-2334-2829</p> <p><b>China - Shenzhen</b> Tel: 86-755-8864-2200</p> <p><b>China - Suzhou</b> Tel: 86-186-6233-1526</p> <p><b>China - Wuhan</b> Tel: 86-27-5980-5300</p> <p><b>China - Xian</b> Tel: 86-29-8833-7252</p> <p><b>China - Xiamen</b> Tel: 86-592-2388138</p> <p><b>China - Zhuhai</b> Tel: 86-756-3210040</p>	<p><b>India - Bangalore</b> Tel: 91-80-3090-4444</p> <p><b>India - New Delhi</b> Tel: 91-11-4160-8631</p> <p><b>India - Pune</b> Tel: 91-20-4121-0141</p> <p><b>Japan - Osaka</b> Tel: 81-6-6152-7160</p> <p><b>Japan - Tokyo</b> Tel: 81-3-6880-3770</p> <p><b>Korea - Daegu</b> Tel: 82-53-744-4301</p> <p><b>Korea - Seoul</b> Tel: 82-2-554-7200</p> <p><b>Malaysia - Kuala Lumpur</b> Tel: 60-3-7651-7906</p> <p><b>Malaysia - Penang</b> Tel: 60-4-227-8870</p> <p><b>Philippines - Manila</b> Tel: 63-2-634-9065</p> <p><b>Singapore</b> Tel: 65-6334-8870</p> <p><b>Taiwan - Hsin Chu</b> Tel: 886-3-577-8366</p> <p><b>Taiwan - Kaohsiung</b> Tel: 886-7-213-7830</p> <p><b>Taiwan - Taipei</b> Tel: 886-2-2508-8600</p> <p><b>Thailand - Bangkok</b> Tel: 66-2-694-1351</p> <p><b>Vietnam - Ho Chi Minh</b> Tel: 84-28-5448-2100</p>	<p><b>Austria - Wels</b> Tel: 43-7242-2244-39 Fax: 43-7242-2244-393</p> <p><b>Denmark - Copenhagen</b> Tel: 45-4485-5910 Fax: 45-4485-2829</p> <p><b>Finland - Espoo</b> Tel: 358-9-4520-820</p> <p><b>France - Paris</b> Tel: 33-1-69-53-63-20 Fax: 33-1-69-30-90-79</p> <p><b>Germany - Garching</b> Tel: 49-8931-9700</p> <p><b>Germany - Haan</b> Tel: 49-2129-3766400</p> <p><b>Germany - Heilbronn</b> Tel: 49-7131-72400</p> <p><b>Germany - Karlsruhe</b> Tel: 49-721-625370</p> <p><b>Germany - Munich</b> Tel: 49-89-627-144-0 Fax: 49-89-627-144-44</p> <p><b>Germany - Rosenheim</b> Tel: 49-8031-354-560</p> <p><b>Israel - Ra'anana</b> Tel: 972-9-744-7705</p> <p><b>Italy - Milan</b> Tel: 39-0331-742611 Fax: 39-0331-466781</p> <p><b>Italy - Padova</b> Tel: 39-049-7625286</p> <p><b>Netherlands - Drunen</b> Tel: 31-416-690399 Fax: 31-416-690340</p> <p><b>Norway - Trondheim</b> Tel: 47-72884388</p> <p><b>Poland - Warsaw</b> Tel: 48-22-3325737</p> <p><b>Romania - Bucharest</b> Tel: 40-21-407-87-50</p> <p><b>Spain - Madrid</b> Tel: 34-91-708-08-90 Fax: 34-91-708-08-91</p> <p><b>Sweden - Gothenberg</b> Tel: 46-31-704-60-40</p> <p><b>Sweden - Stockholm</b> Tel: 46-8-5090-4654</p> <p><b>UK - Wokingham</b> Tel: 44-118-921-5800 Fax: 44-118-921-5820</p>

## X-ON Electronics

Largest Supplier of Electrical and Electronic Components

*Click to view similar products for [8-bit Microcontrollers - MCU category](#):*

*Click to view products by [Microchip manufacturer](#):*

Other Similar products are found below :

[CY8C20524-12PVXIT](#) [CY8C28433-24PVXIT](#) [MB95F012KPFT-G-SNE2](#) [MB95F013KPMC-G-SNE2](#) [MB95F263KPF-G-SNE2](#)  
[MB95F264KPFT-G-SNE2](#) [MB95F398KPMC-G-SNE2](#) [MB95F478KPMC2-G-SNE2](#) [MB95F562KPF-G-SNE2](#) [MB95F564KPF-G-SNE2](#)  
[MB95F634KPMC-G-SNE2](#) [MB95F636KWQN-G-SNE1](#) [MB95F696KPMC-G-SNE2](#) [MB95F698KPMC1-G-SNE2](#) [MB95F698KPMC2-G-SNE2](#) [MB95F698KPMC-G-SNE2](#) [MB95F818KPMC1-G-SNE2](#) [MC908JK1ECDWER](#) [MC9S08PA32AVLD](#) [MC9S08PT60AVLD](#)  
[R5F1076CMSPV0](#) [R5F5631ECDFBV0](#) [C8051F389-B-GQ](#) [C8051F392-A-GMR](#) [ISD-ES1600\\_USB\\_PROG](#) [901015X](#) [S9S08SL8F1CTJR](#)  
[SC705C8AE0VFBE](#) [STM8TL53G4U6](#) [PIC16F877-04/P-B](#) [R5F10Y17ASP#30](#) [CY8C3MFIDOCK-125](#) [403708R](#) [MB95F354EPF-G-SNE2](#)  
[MB95F564KPFT-G-SNE2](#) [MB95F564KWQN-G-SNE1](#) [MB95F636KP-G-SH-SNE2](#) [MB95F636KPMC-G-SNE2](#) [MB95F694KPMC-G-SNE2](#)  
[MB95F778JPMC1-G-SNE2](#) [MB95F818KPMC-G-SNE2](#) [MC908QY8CDWER](#) [MC9S08PT16AVLD](#) [MC9S08PT32AVLH](#)  
[MC9S08PT60AVLC](#) [MC9S08PT60AVLH](#) [C8051F500-IQR](#) [LC87F0G08AUJA-AH](#) [CP8361BT](#) [STM8S207C6T3](#)