



# PIC18F87J72 FAMILY

## 80-Pin, High-Performance Microcontrollers with Dual-Channel AFE and LCD Driver

### Analog Features:

- Dual-Channel, 24-Bit Analog Front End (AFE):
  - 90 dB SINAD, -101 dBc THD (to 35th harmonic), 103 dB SFDR for each channel
  - 10 ppm INL
  - Differential voltage input pins
  - Low drift internal voltage reference (12 ppm/°C)
  - Programmable data rate to 64 ksps
  - High-gain PGA on each channel (up to 32 V/V)
  - Phase delay compensation between channels (1  $\mu$ s resolution)
- 12-Bit, 12-Channel SAR A/D Converter:
  - Auto-acquisition
  - Conversion available during Sleep
- Two Analog Comparators
- Programmable Reference Voltage for Comparators
- Charge Time Measurement Unit (CTMU):
  - Capacitance measurement
  - Time measurement with 1 ns typical resolution
  - Temperature sensing

### LCD Driver and Keypad Interface Features:

- Direct LCD Panel Drive Capability:
  - Can drive LCD panel while in Sleep mode
  - Wake-up from interrupt
- Up to 33 Segments and 132 Pixels: Software Selectable
- Programmable LCD Timing module:
  - Multiple LCD timing sources available
  - Up to four commons: static, 1/2, 1/3 or 1/4 multiplex
  - Static, 1/2 or 1/3 bias configuration
- On-Chip LCD Boost Voltage Regulator for Contrast Control
- CTMU for Capacitive Touch Sensing
- ADC for Resistive Touch Sensing

### Flexible Oscillator Structure:

- External Crystal and Clock modes, with operation up to 48 MHz
- 4x Phase Lock Loop (PLL)
- Internal Oscillator Block with PLL:
  - Eight user-selectable frequencies from 31.25 kHz to 8 MHz
- Secondary Oscillator using Timer1 at 32 kHz
- Fail-Safe Clock Monitor (FSCM):
  - Allows for safe shutdown if peripheral clock fails

### Low-Power Features:

- Power-Managed modes:
  - Run: CPU on, peripherals on
  - Idle: CPU off, peripherals on
  - Sleep: CPU off, peripherals off
- Two-Speed Oscillator Start-up

### Peripheral Highlights:

- High-Current Sink/Source 25 mA/25 mA (PORTB and PORTC)
- Up to Four External Interrupts
- Four 8-Bit/16-Bit Timer/Counter modules
- Two Capture/Compare/PWM (CCP) modules
- Master Synchronous Serial Port (MSSP) module with Two Modes of Operation:
  - 3-wire/4-wire SPI (supports all four SPI modes)
  - I<sup>2</sup>C Master and Slave mode
- One Addressable USART module
- One Enhanced Addressable USART module:
  - LIN/J2602 support
  - Auto-wake-up on Start bit and Break character
  - Auto-Baud Detect (ABD)
- Hardware Real-Time Clock and Calendar (RTCC) with Clock, Calendar and Alarm Functions

### Special Microcontroller Features:

- 10,000 Erase/Write Cycle Flash Program Memory, Typical
- Flash Retention 20 Years, Minimum
- Self-Programmable under Software Control
- Word Write Capability for Flash Program Memory for Data EEPROM Emulators
- Priority Levels for Interrupts
- 8 x 8 Single-Cycle Hardware Multiplier
- Extended Watchdog Timer (WDT):
  - Programmable period from 4 ms to 131s
- Selectable Open-Drain Configuration for Serial Communication and CCP pins for Driving Outputs up to 5V
- In-Circuit Serial Programming™ (ICSP™) via Two Pins
- In-Circuit Debug via Two Pins
- Operating Voltage Range: 4.5V to 5.5V ( $\Delta\Sigma$  ADC), 2.0V to 3.6V (digital and SAR ADC)
- 5.5V Tolerant Input (digital pins only)
- On-Chip 2.5V Regulator

### Target Applications:

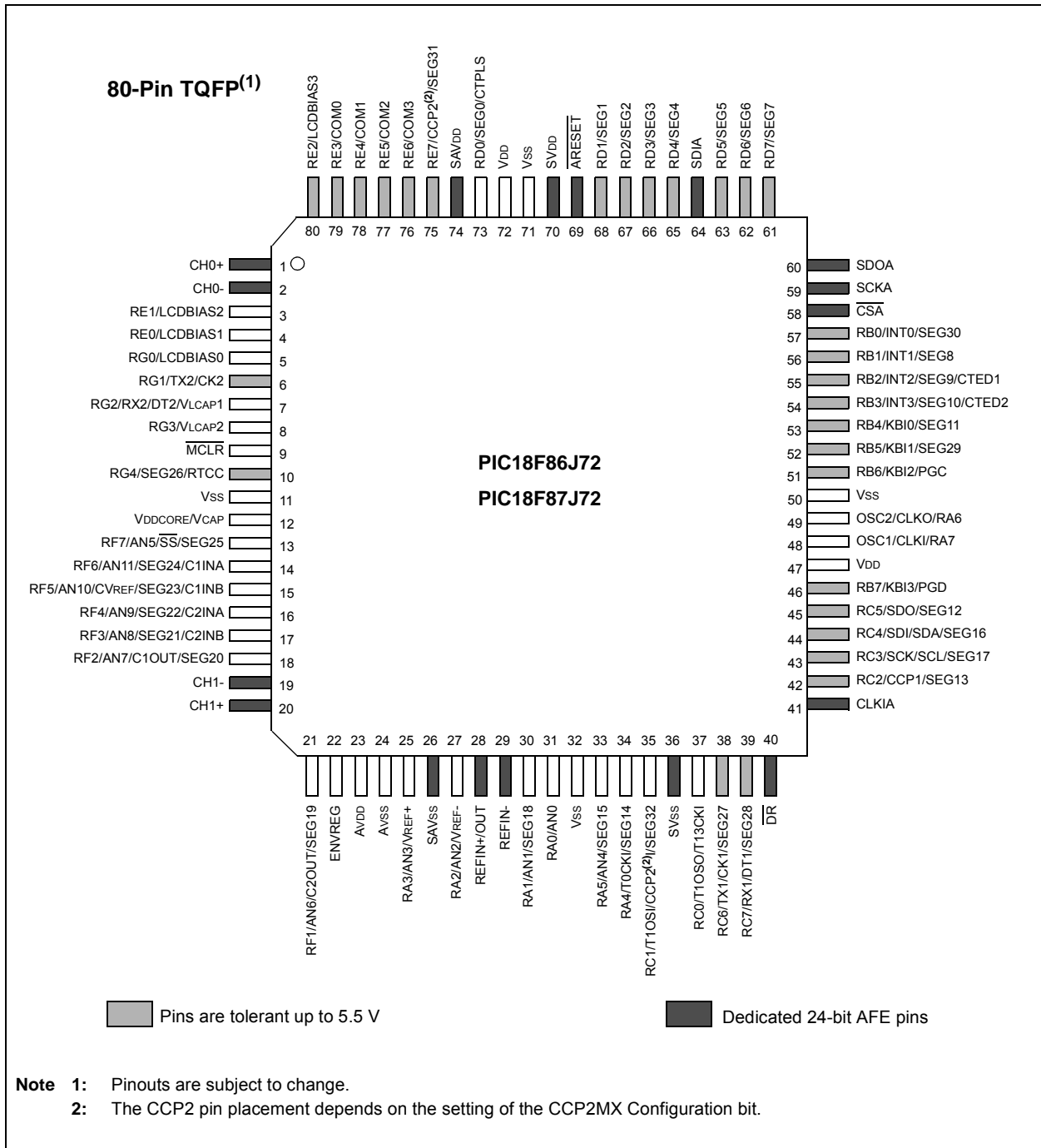
- Energy Metering
- Power Measurement and Monitoring
- Portable Instrumentation
- Medical Monitoring

# PIC18F87J72

TABLE 1: PIC18F87J72 FAMILY TYPES

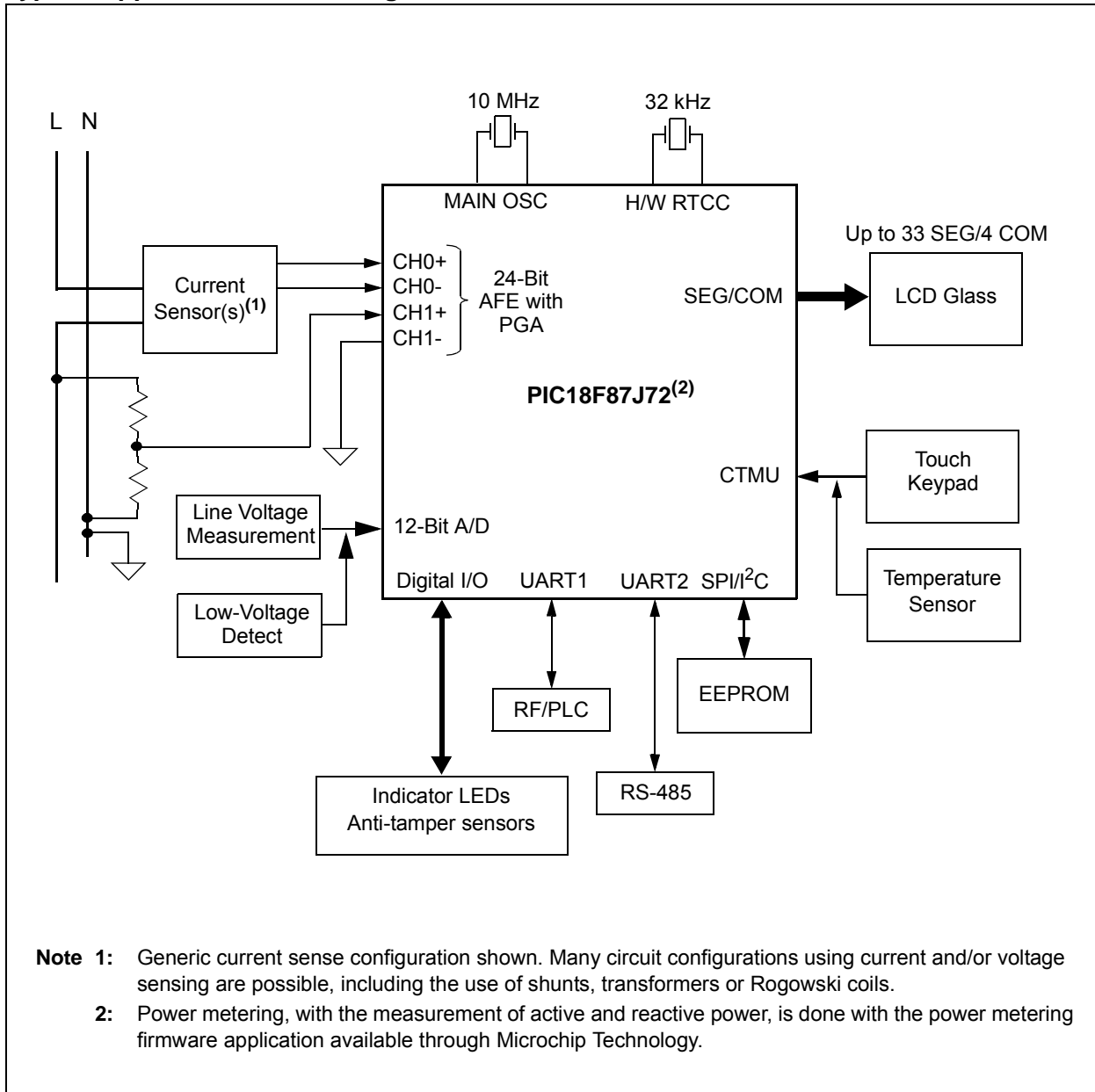
Device	Flash Program Memory (bytes)	SRAM Data Memory (bytes)	LCD (Pixels)	I/O	A/D		Comparators	CCP	BOR/LVD	MSSP	A/EUSART	Timers 8-bit/16-bit	RTCC	CTMU
					12-Bit SAR (channels)	24-bit AFE (channels)								
PIC18F86J72	64K	3,923	132	51	12	2	2	2	Y	1	1/1	1/3	Y	Y
PIC18F87J72	128K	3,923	132	51	12	2	2	2	Y	1	1/1	1/3	Y	Y

## Pin Diagram



# PIC18F87J72

## Typical Application Circuit: Single-Phase Power Meter



## Table of Contents

1.0	Device Overview .....	7
2.0	Guidelines for Getting Started with PIC18FJ Microcontrollers .....	19
3.0	Oscillator Configurations .....	23
4.0	Power-Managed Modes .....	32
5.0	Reset .....	39
6.0	Memory Organization .....	51
7.0	Flash Program Memory .....	73
8.0	8 x 8 Hardware Multiplier .....	83
9.0	Interrupts .....	85
10.0	I/O Ports .....	101
11.0	Timer0 Module .....	120
12.0	Timer1 Module .....	123
13.0	Timer2 Module .....	129
14.0	Timer3 Module .....	131
15.0	Real-Time Clock and Calendar (RTCC) .....	134
16.0	Capture/Compare/PWM (CCP) Modules .....	151
17.0	Liquid Crystal Display (LCD) Driver Module .....	160
18.0	Master Synchronous Serial Port (MSSP) Module .....	187
19.0	Enhanced Universal Synchronous Asynchronous Receiver Transmitter (EUSART) .....	231
20.0	Addressable Universal Synchronous Asynchronous Receiver Transmitter (AUSART) .....	252
21.0	12-Bit Analog-to-Digital Converter (A/D) Module .....	266
22.0	Dual-Channel, 24-Bit Analog Front End (AFE) .....	275
23.0	Comparator Module .....	285
24.0	Comparator Voltage Reference Module .....	290
25.0	Charge Time Measurement Unit (CTMU) .....	293
26.0	Special Features of the CPU .....	308
27.0	Instruction Set Summary .....	321
28.0	Development Support .....	372
29.0	Electrical Characteristics .....	376
30.0	Packaging Information .....	417
	Appendix A: Revision History .....	420
	Appendix B: Dual-Channel, 24-Bit AFE Reference .....	421
	The Microchip Website .....	451
	Customer Change Notification Service .....	451
	Customer Support .....	451
	Product Identification System .....	452

## TO OUR VALUED CUSTOMERS

It is our intention to provide our valued customers with the best documentation possible to ensure successful use of your Microchip products. To this end, we will continue to improve our publications to better suit your needs. Our publications will be refined and enhanced as new volumes and updates are introduced.

If you have any questions or comments regarding this publication, please contact the Marketing Communications Department via E-mail at [docerrors@microchip.com](mailto:docerrors@microchip.com). We welcome your feedback.

### Most Current Data Sheet

To obtain the most up-to-date version of this data sheet, please register at our Worldwide Website at:

<http://www.microchip.com>

You can determine the version of a data sheet by examining its literature number found on the bottom outside corner of any page. The last character of the literature number is the version number, (e.g., DS30000000A is version A of document DS30000000).

### Errata

An errata sheet, describing minor operational differences from the data sheet and recommended workarounds, may exist for current devices. As device/documentation issues become known to us, we will publish an errata sheet. The errata will specify the revision of silicon and revision of document to which it applies.

To determine if an errata sheet exists for a particular device, please check with one of the following:

- Microchip's Worldwide Website; <http://www.microchip.com>
- Your local Microchip sales office (see last page)

When contacting a sales office, please specify which device, revision of silicon and data sheet (include literature number) you are using.

### Customer Notification System

Register on our website at [www.microchip.com](http://www.microchip.com) to receive the most current information on all of our products.

## 1.0 DEVICE OVERVIEW

This document contains device-specific information for the following devices:

- PIC18F86J72
- PIC18F87J72

This family combines the traditional advantages of all PIC18 microcontrollers – namely, high computational performance and a rich feature set – with a versatile on-chip LCD driver and a high-performance, high-accuracy analog front end. These features make the PIC18F87J72 family a logical choice for many high-performance power and metering applications where price is a primary consideration.

### 1.1 Core Features

#### 1.1.1 LOW-POWER MODES

All of the devices in the PIC18F87J72 family incorporate a range of features that can significantly reduce power consumption during operation. Key items include:

- **Alternate Run Modes:** By clocking the controller from the Timer1 source or the internal RC oscillator, power consumption during code execution can be reduced by as much as 90%.
- **Multiple Idle Modes:** The controller can also run with its CPU core disabled but the peripherals still active. In these states, power consumption can be reduced even further, to as little as 4% of normal operation requirements.
- **On-the-Fly Mode Switching:** The power-managed modes are invoked by user code during operation, allowing the user to incorporate power-saving ideas into their application's software design.

#### 1.1.2 OSCILLATOR OPTIONS AND FEATURES

All of the devices in the PIC18F87J72 family offer six different oscillator options, allowing users a range of choices in developing application hardware. These include:

- Two Crystal modes using crystals or ceramic resonators.
- Two External Clock modes offering the option of a divide-by-4 clock output.
- A Phase Lock Loop (PLL) frequency multiplier, available to the external oscillator modes which allows clock speeds of up to 40 MHz. PLL can also be used with the internal oscillator.
- An internal oscillator block which provides an 8 MHz clock ( $\pm 2\%$  accuracy) and an INTRC source (approximately 31 kHz, stable over temperature and VDD), as well as a range of six user-selectable clock frequencies, between 125 kHz to 4 MHz, for a total of eight clock frequencies. This option frees the two oscillator pins for use as additional general purpose I/O.

The internal oscillator block provides a stable reference source that gives the family additional features for robust operation:

- **Fail-Safe Clock Monitor:** This option constantly monitors the main clock source against a reference signal provided by the internal oscillator. If a clock failure occurs, the controller is switched to the internal oscillator, allowing for continued low-speed operation or a safe application shutdown.
- **Two-Speed Start-up:** This option allows the internal oscillator to serve as the clock source from Power-on Reset, or wake-up from Sleep mode, until the primary clock source is available.

#### 1.1.3 MEMORY OPTIONS

The PIC18F87J72 family provides ample room for application code with 128 Kbytes of code space. The Flash cells for program memory are rated to last up to 10,000 erase/write cycles. Data retention without refresh is conservatively estimated to be greater than 20 years.

The Flash program memory is readable and writable. During normal operation, the PIC18F87J72 family also provides plenty of room for dynamic application data with up to 3,923 bytes of data RAM.

#### 1.1.4 EXTENDED INSTRUCTION SET

The PIC18F87J72 family implements the optional extension to the PIC18 instruction set, adding 8 new instructions and an Indexed Addressing mode. Enabled as a device configuration option, the extension has been specifically designed to optimize re-entrant application code originally developed in high-level languages, such as 'C'.

#### 1.1.5 EASY MIGRATION

Regardless of the memory size, all devices share the same rich set of peripherals, allowing for a smooth migration path as applications grow and evolve.

The consistent pinout scheme used throughout the entire family also aids in migrating to the next larger device.

The PIC18F87J72 family is also largely pin compatible with other PIC18 families, such as the PIC18F8720 and PIC18F8722, the PIC18F85J11, and the PIC18F8490 and PIC18F85J90 families of microcontrollers with LCD drivers. This allows a new dimension to the evolution of applications, allowing developers to select different price points within Microchip's PIC18 portfolio, while maintaining a similar feature set.

# PIC18F86J72

---

## 1.2 Analog Features

- **Dual-Channel, 24-Bit ADC Front End (AFE):** This module contains two synchronous sampling,  $\Delta\Sigma$  Analog-to-Digital (A/D) Converters, plus supporting Programmable Gain Amplifiers (PGAs) and an internal voltage reference, to perform high-accuracy and low noise analog conversions. The AFE is controlled, and its data read, through a dedicated, high-speed (20 MHz) SPI interface.
- **12-Bit A/D Converter:** In addition to the AFE, PIC18F87J72 family devices also include a standard SAR A/D Converter with 12 independent analog inputs. The module incorporates programmable acquisition time, allowing for a channel to be selected and a conversion to be initiated without waiting for a sampling period and thus, reducing code overhead.
- **Charge Time Measurement Unit (CTMU):** The CTMU is a flexible analog module that provides accurate differential time measurement between pulse sources, as well as asynchronous pulse generation. Together with other on-chip analog modules, the CTMU can precisely measure time, measure capacitance or relative changes in capacitance, or generate output pulses that are independent of the system clock.

## 1.3 LCD Driver

The on-chip LCD driver includes many features that make the integration of displays in low-power applications easier. These include an integrated voltage regulator with charge pump that allows contrast control in software and display operation above device  $V_{DD}$ .

## 1.4 Other Special Features

- **Communications:** The PIC18F87J72 family incorporates a range of serial communication peripherals, including an Addressable USART, a separate Enhanced USART that supports LIN/J2602 specification 1.2, and one Master SSP module capable of both SPI and  $I^2C$  (Master and Slave) modes of operation.
- **CCP Modules:** All devices in the family incorporate two Capture/Compare/PWM (CCP) modules. Up to four different time bases may be used to perform several different operations at once.
- **Extended Watchdog Timer (WDT):** This enhanced version incorporates a 16-bit prescaler, allowing an extended time-out range that is stable across operating voltage and temperature. See [Section 29.0 “Electrical Characteristics”](#) for time-out periods.
- **Real Time Clock and Calendar Module (RTCC):** The RTCC module is intended for applications requiring that accurate time be maintained for extended periods of time with minimum to no intervention from the CPU. The module is a 100-year clock and calendar with automatic leap year detection. The range of the clock is from 00:00:00 (midnight) on January 1, 2000 to 23:59:59 on December 31, 2099.



## 1.5 Details on Individual Family Members

Devices in the PIC18F87J72 family are available in 80-pin packages. Block diagrams for the two groups are shown in [Figure 1-1](#).

The devices are differentiated in that PIC18F86J72 devices have a Flash program memory of 64 Kbytes and PIC18F87J72 devices memory is 128 Kbytes

All other features for the devices are identical. These are summarized in [Table 1-1](#).

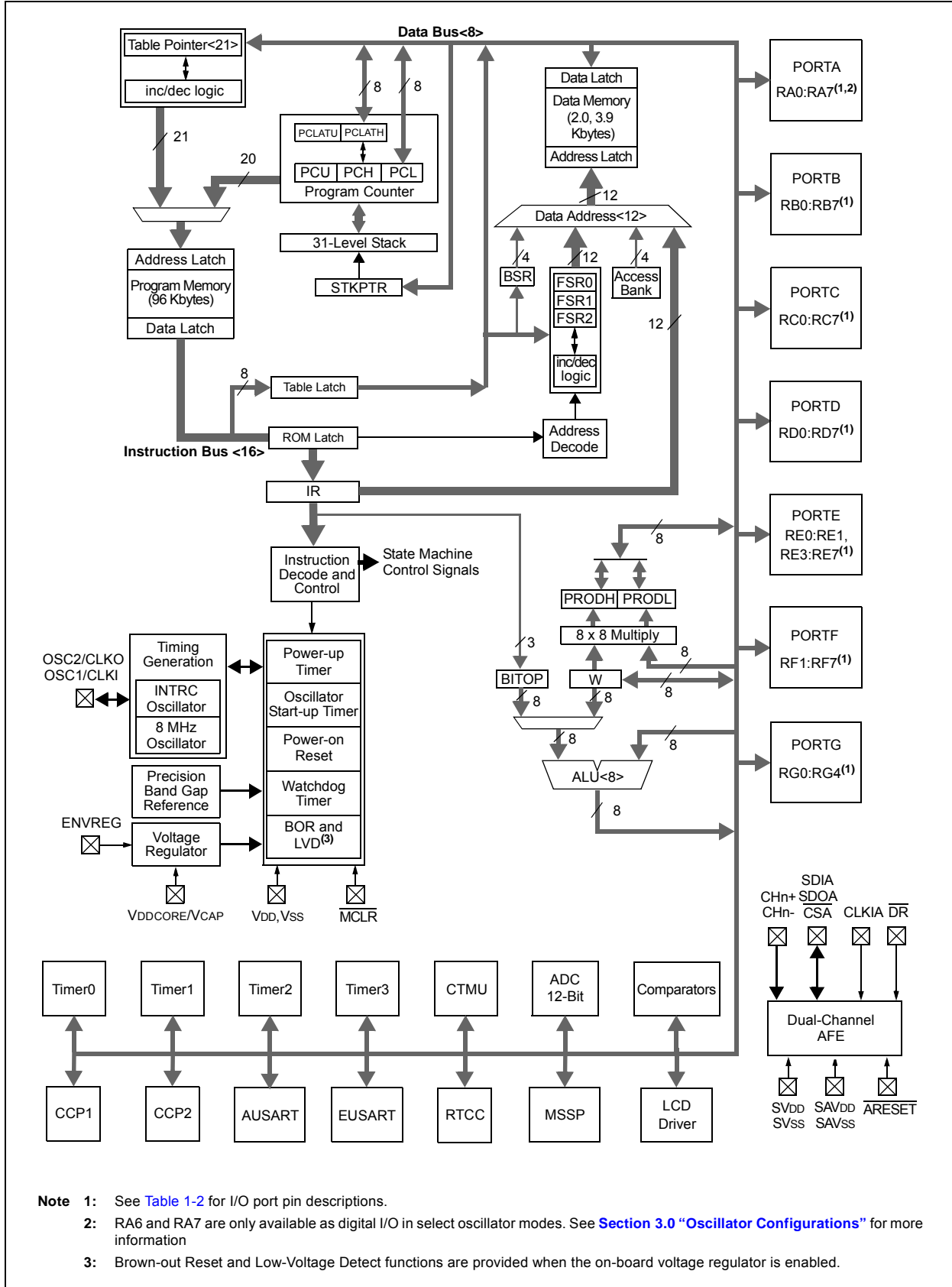
The pinouts for all devices are listed in [Table 1-2](#).

**TABLE 1-1: DEVICE FEATURES FOR THE PIC18F8XJ72 (80-PIN DEVICES)**

Features	PIC18F86J72	PIC18F87J72
Operating Frequency	DC – 48 MHz	
Program Memory (Bytes)	64K	128K
Program Memory (Instructions)	32,768	65,536
Data Memory (Bytes)	3,923	3,923
Interrupt Sources	29	
I/O Ports	Ports A, B, C, D, E, F, G	
LCD Driver (available pixels to drive)	132 (33 SEGs x 4 COMs)	
Timers	4	
Comparators	2	
CTMU	Yes	
RTCC	Yes	
Capture/Compare/PWM Modules	2	
Serial Communications	MSSP, Addressable USART, Enhanced USART	
12-Bit Analog-to-Digital Module	12 Input Channels	
Dual-Channel 24-Bit Analog Front End	Yes	
Resets (and Delays)	POR, BOR, RESET Instruction, Stack Full, Stack Underflow, MCLR, WDT (PWRT, OST)	
Instruction Set	75 Instructions, 83 with Extended Instruction Set Enabled	
Packages	80-Pin TQFP	

# PIC18F86J72

FIGURE 1-1: PIC18F8XJ72 (80-PIN) BLOCK DIAGRAM





# PIC18F86J72

**TABLE 1-2: PIC18F8XJ72 PINOUT I/O DESCRIPTIONS (CONTINUED)**

Pin Name	Pin Number	Pin Type	Buffer Type	Description
	TQFP			
				PORTB is a bidirectional I/O port. PORTB can be software programmed for internal weak pull-ups on all inputs.
RB0/INT0/SEG30 RB0 INT0 SEG30	57	I/O I O	TTL ST Analog	Digital I/O. External Interrupt 0. SEG30 output for LCD.
RB1/INT1/SEG8 RB1 INT1 SEG8	56	I/O I O	TTL ST Analog	Digital I/O. External Interrupt 1. SEG8 output for LCD.
RB2/INT2/SEG9/ CTED1 RB2 INT2 CTED1 SEG9	55	I/O I I O	TTL ST ST Analog	Digital I/O. External Interrupt 2. CTMU Edge 1 input. SEG9 output for LCD.
RB3/INT3/SEG10/ CTED2 RB3 INT3 SEG10 CTED2	54	I/O I O I	TTL ST Analog ST	Digital I/O. External Interrupt 3. SEG10 output for LCD. CTMU Edge 2 input.
RB4/KBI0/SEG11 RB4 KBI0 SEG11	53	I/O I O	TTL TTL Analog	Digital I/O. Interrupt-on-change pin. SEG11 output for LCD.
RB5/KBI1/SEG29 RB5 KBI1 SEG29	52	I/O I O	TTL TTL Analog	Digital I/O. Interrupt-on-change pin. SEG29 output for LCD.
RB6/KBI2/PGC RB6 KBI2 PGC	51	I/O I I/O	TTL TTL ST	Digital I/O. Interrupt-on-change pin. In-Circuit Debugger and ICSP™ programming clock pin.
RB7/KBI3/PGD RB7 KBI3 PGD	46	I/O I I/O	TTL TTL ST	Digital I/O. Interrupt-on-change pin. In-Circuit Debugger and ICSP programming data pin.

**Legend:** TTL = TTL compatible input      CMOS = CMOS compatible input or output  
 ST = Schmitt Trigger input with CMOS levels      Analog = Analog input  
 I<sup>2</sup>C = I<sup>2</sup>C/SMBus compatible input      OD = Open-Drain (no P diode to VDD)  
 I = Input      O = Output  
 P = Power

**Note 1:** Default assignment for CCP2 when the CCP2MX Configuration bit is set.  
**Note 2:** Alternate assignment for CCP2 when the CCP2MX Configuration bit is cleared.

**TABLE 1-2: PIC18F8XJ72 PINOUT I/O DESCRIPTIONS (CONTINUED)**

Pin Name	Pin Number	Pin Type	Buffer Type	Description
	TQFP			
RC0/T1OSO/T13CKI	37	I/O	ST	PORTC is a bidirectional I/O port. Digital I/O. Timer1 oscillator output. Timer1/Timer3 external clock input.
RC0		O	—	
T1OSO		I	ST	
T13CKI				
RC1/T1OSI/CCP2/SEG32	35	I/O	ST	Digital I/O. Timer1 oscillator input. Capture 2 input/Compare 2 output/PWM2 output. SEG32 output for LCD.
RC1		I	CMOS	
T1OSI		I/O	ST	
CCP2 <sup>(1)</sup> SEG32		O	Analog	
RC2/CCP1/SEG13	42	I/O	ST	Digital I/O. Capture 1 input/Compare 1 output/PWM1 output. SEG13 output for LCD.
RC2		I/O	ST	
CCP1		O	Analog	
SEG13				
RC3/SCK/SCL/SEG17	43	I/O	ST	Digital I/O. Synchronous serial clock input/output for SPI mode. Synchronous serial clock input/output for I <sup>2</sup> C mode. SEG17 output for LCD.
RC3		I/O	ST	
SCK		I/O	I <sup>2</sup> C	
SCL		O	Analog	
SEG17				
RC4/SDI/SDA/SEG16	44	I/O	ST	Digital I/O. SPI data in. I <sup>2</sup> C data I/O. SEG16 output for LCD.
RC4		I	ST	
SDI		I/O	I <sup>2</sup> C	
SDA		O	Analog	
SEG16				
RC5/SDO/SEG12	45	I/O	ST	Digital I/O. SPI data out. SEG12 output for LCD.
RC5		O	—	
SDO		O	Analog	
SEG12				
RC6/TX1/CK1/SEG27	38	I/O	ST	Digital I/O. EUSART asynchronous transmit. EUSART synchronous clock (see related RX1/DT1). SEG27 output for LCD.
RC6		O	—	
TX1		I/O	ST	
CK1		O	Analog	
SEG27				
RC7/RX1/DT1/SEG28	39	I/O	ST	Digital I/O. EUSART asynchronous receive. EUSART synchronous data (see related TX1/CK1). SEG28 output for LCD.
RC7		I	ST	
RX1		I/O	ST	
DT1		O	Analog	
SEG28				

**Legend:** TTL = TTL compatible input      CMOS = CMOS compatible input or output  
 ST = Schmitt Trigger input with CMOS levels      Analog = Analog input  
 I<sup>2</sup>C = I<sup>2</sup>C/SMBus compatible input      OD = Open-Drain (no P diode to VDD)  
 I = Input      O = Output  
 P = Power

**Note 1:** Default assignment for CCP2 when the CCP2MX Configuration bit is set.  
**Note 2:** Alternate assignment for CCP2 when the CCP2MX Configuration bit is cleared.

# PIC18F86J72

**TABLE 1-2: PIC18F8XJ72 PINOUT I/O DESCRIPTIONS (CONTINUED)**

Pin Name	Pin Number	Pin Type	Buffer Type	Description
	TQFP			
RD0/SEG0/CTPLS	73	I/O	ST	PORTD is a bidirectional I/O port. Digital I/O. SEG0 output for LCD. CTMU pulse generator output.
RD0		O	Analog	
SEG0		O	—	
RD1/SEG1	68	I/O	ST	Digital I/O. SEG1 output for LCD.
RD1		O	Analog	
RD2/SEG2	67	I/O	ST	Digital I/O. SEG2 output for LCD.
RD2		O	Analog	
RD3/SEG3	66	I/O	ST	Digital I/O. SEG3 output for LCD.
RD3		O	Analog	
RD4/SEG4	65	I/O	ST	Digital I/O. SEG4 output for LCD.
RD4		O	Analog	
RD5/SEG5	63	I/O	ST	Digital I/O. SEG5 output for LCD.
RD5		O	Analog	
RD6/SEG6	62	I/O	ST	Digital I/O. SEG6 output for LCD.
RD6		O	Analog	
RD7/SEG7	61	I/O	ST	Digital I/O. SEG7 output for LCD.
RD7		O	Analog	

**Legend:** TTL = TTL compatible input      CMOS = CMOS compatible input or output  
 ST = Schmitt Trigger input with CMOS levels      Analog = Analog input  
 I<sup>2</sup>C = I<sup>2</sup>C/SMBus compatible input      OD = Open-Drain (no P diode to VDD)  
 I = Input      O = Output  
 P = Power

**Note 1:** Default assignment for CCP2 when the CCP2MX Configuration bit is set.  
**Note 2:** Alternate assignment for CCP2 when the CCP2MX Configuration bit is cleared.

**TABLE 1-2: PIC18F8XJ72 PINOUT I/O DESCRIPTIONS (CONTINUED)**

Pin Name	Pin Number	Pin Type	Buffer Type	Description
	TQFP			
RE0/LCDBIAS1 RE0 LCDBIAS1	4	I/O I	ST Analog	<p>PORTE is a bidirectional I/O port.</p> <p>Digital I/O. BIAS1 input for LCD.</p>
RE1/LCDBIAS2 RE1 LCDBIAS2	3	I/O I	ST Analog	<p>Digital I/O. BIAS2 input for LCD.</p>
RE2/LCDBIAS3 RE2 LCDBIAS3	80	I/O I	ST Analog	<p>Digital I/O. BIAS3 input for LCD.</p>
RE3/COM0 RE3 COM0	79	I/O O	ST Analog	<p>Digital I/O. COM0 output for LCD.</p>
RE4/COM1 RE4 COM1	78	I/O O	ST Analog	<p>Digital I/O. COM1 output for LCD.</p>
RE5/COM2 RE5 COM2	77	I/O O	ST Analog	<p>Digital I/O. COM2 output for LCD.</p>
RE6/COM3 RE6 COM3	76	I/O O	ST Analog	<p>Digital I/O. COM3 output for LCD.</p>
RE7/CCP2/SEG31 RE7 CCP2 <sup>(2)</sup> SEG31	75	I/O I/O O	ST ST Analog	<p>Digital I/O. Capture 2 input/Compare 2 output/PWM2 output. SEG31 output for LCD.</p>

**Legend:** TTL = TTL compatible input      CMOS = CMOS compatible input or output  
ST = Schmitt Trigger input with CMOS levels      Analog = Analog input  
I<sup>2</sup>C = I<sup>2</sup>C/SMBus compatible input      OD = Open-Drain (no P diode to VDD)  
I = Input      O = Output  
P = Power

- Note 1:** Default assignment for CCP2 when the CCP2MX Configuration bit is set.  
**2:** Alternate assignment for CCP2 when the CCP2MX Configuration bit is cleared.

# PIC18F86J72

**TABLE 1-2: PIC18F8XJ72 PINOUT I/O DESCRIPTIONS (CONTINUED)**

Pin Name	Pin Number	Pin Type	Buffer Type	Description
	TQFP			
RF1/AN6/C2OUT/ SEG19	21			PORTF is a bidirectional I/O port.
RF1		I/O	ST	Digital I/O.
AN6		I	Analog	Analog Input 6.
C2OUT		O	—	Comparator 2 output.
SEG19		O	Analog	SEG19 output for LCD.
RF2/AN7/C1OUT/ SEG20	18			
RF2		I/O	ST	Digital I/O.
AN7		I	Analog	Analog Input 7.
C1OUT		O	—	Comparator 1 output.
SEG20		O	Analog	SEG20 output for LCD.
RF3/AN8/SEG21/ C2INB	17			
RF3		I/O	ST	Digital I/O.
AN8		I	Analog	Analog Input 8.
SEG21		O	Analog	SEG21 output for LCD.
C2INB		I	Analog	Comparator 2 Input B.
RF4/AN9/SEG22/ C2INA	16			
RF4		I/O	ST	Digital I/O.
AN9		I	Analog	Analog Input 9.
SEG22		O	Analog	SEG22 output for LCD
C2INA		I	Analog	Comparator 2 Input A.
RF5/AN10/CVREF/ SEG23/C1INB	15			
RF5		I/O	ST	Digital I/O.
AN10		I	Analog	Analog Input 10.
CVREF		O	Analog	Comparator reference voltage output.
SEG23		O	Analog	SEG23 output for LCD.
C1INB		I	Analog	Comparator 1 Input B.
RF6/AN11/SEG24/ C1INA	14			
RF6		I/O	ST	Digital I/O.
AN11		I	Analog	Analog Input 11.
SEG24		O	Analog	SEG24 output for LCD
C1INA		I	Analog	Comparator 1 Input A.
RF7/AN5/ $\overline{SS}$ /SEG25	13			
RF7		I/O	ST	Digital I/O.
AN5		O	Analog	Analog Input 5.
$\overline{SS}$		I	TTL	SPI slave select input.
SEG25		O	Analog	SEG25 output for LCD.

**Legend:** TTL = TTL compatible input  
 ST = Schmitt Trigger input with CMOS levels  
 $I^2C$  =  $I^2C$ /SMBus compatible input  
 I = Input  
 P = Power  
 CMOS = CMOS compatible input or output  
 Analog = Analog input  
 OD = Open-Drain (no P diode to VDD)  
 O = Output

**Note 1:** Default assignment for CCP2 when the CCP2MX Configuration bit is set.  
**2:** Alternate assignment for CCP2 when the CCP2MX Configuration bit is cleared.



**TABLE 1-2: PIC18F8XJ72 PINOUT I/O DESCRIPTIONS (CONTINUED)**

Pin Name	Pin Number	Pin Type	Buffer Type	Description
	TQFP			
RG0/LCDBIAS0 RG0 LCDBIAS0	5	I/O I	ST Analog	PORTG is a bidirectional I/O port.  Digital I/O. BIAS0 input for LCD.
RG1/TX2/CK2 RG1 TX2 CK2	6	I/O O I/O	ST — ST	Digital I/O. AUSART asynchronous transmit. AUSART synchronous clock (see related RX2/DT2).
RG2/RX2/DT2/VLCAP 1 RG2 RX2 DT2 VLCAP1	7	I/O I I/O I	ST ST ST Analog	Digital I/O. AUSART asynchronous receive. AUSART synchronous data (see related TX2/CK2). LCD charge pump capacitor input.
RG3/VLCAP2 RG3 VLCAP2	8	I/O I	ST Analog	Digital I/O. LCD charge pump capacitor input.
RG4/SEG26/RTCC RG4 SEG26 RTCC	10	I/O O O	ST Analog —	Digital I/O. SEG26 output for LCD. RTCC output.
Vss	11,32,50, 71	P	—	Ground reference for logic and I/O pins.
VDD	47, 72	P	—	Positive supply for logic and I/O pins.
AVss	24	P	—	Ground reference for analog modules.
AVDD	23	P	—	Positive supply for analog modules.
ENVREG	22	I	ST	Enable for on-chip voltage regulator.
VDDCORE/VCAP VDDCORE  VCAP	12	P  P	—  —	Core logic power or external filter capacitor connection. Positive supply for microcontroller core logic (regulator disabled).  External filter capacitor connection (regulator enabled).

**Legend:** TTL = TTL compatible input  
ST = Schmitt Trigger input with CMOS levels  
I<sup>2</sup>C = I<sup>2</sup>C/SMBus compatible input  
I = Input  
P = Power

CMOS = CMOS compatible input or output  
Analog = Analog input  
OD = Open-Drain (no P diode to VDD)  
O = Output

**Note 1:** Default assignment for CCP2 when the CCP2MX Configuration bit is set.

**2:** Alternate assignment for CCP2 when the CCP2MX Configuration bit is cleared.

# PIC18F86J72

TABLE 1-2: PIC18F8XJ72 PINOUT I/O DESCRIPTIONS (CONTINUED)

Pin Name	Pin Number	Pin Type	Buffer Type	Description
	TQFP			
RESET	69	I	ST	AFE Master Reset logic input pin.
SVDD	70	P	—	AFE digital power supply pin.
SAVDD	74	P	—	AFE analog power supply reference pin.
CH0+	1	I	Analog	Channel 0 non-inverting analog input pin.
CH0-	2	I	Analog	Channel 0 inverting analog input pin.
CH1-	19	I	Analog	Channel 1 inverting analog input pin.
CH1+	20	I	Analog	Channel 1 Non-Inverting Analog Input Pin
SAVSS	26	P	—	AFE analog ground pin (return path for analog circuitry).
REFIN+/OUT REFIN+ REFOUT	28	I O	Analog Analog	AFE non-inverting voltage reference input. Internal reference output pin.
REFIN-	29	I	Analog	Inverting voltage reference input pin.
SVSS	36	P	—	AFE digital ground pin (return path for digital circuitry).
DR	40		—	AFE data ready signal output pin.
CLKIA	41	I	CMOS	AFE oscillator crystal connection pin or external clock input pin.
CSA	58	I	TTL	AFE serial interface chip select pin.
SCKA	59	I	TTL	AFE serial interface clock pin.
SDOA	60	O	TTL	AFE serial interface data output pin.
SDIA	64	I	TTL	AFE serial interface data input pin.

**Legend:** TTL = TTL compatible input  
ST = Schmitt Trigger input with CMOS levels  
I<sup>2</sup>C = I<sup>2</sup>C/SMBus compatible input  
I = Input  
P = Power  
CMOS = CMOS compatible input or output  
Analog = Analog input  
OD = Open-Drain (no P diode to VDD)  
O = Output

- Note 1:** Default assignment for CCP2 when the CCP2MX Configuration bit is set.  
**Note 2:** Alternate assignment for CCP2 when the CCP2MX Configuration bit is cleared.

## 2.0 GUIDELINES FOR GETTING STARTED WITH PIC18FJ MICROCONTROLLERS

### 2.1 Basic Connection Requirements

Getting started with the PIC18F87J72 family of 8-bit microcontrollers requires attention to a minimal set of device pin connections before proceeding with development.

The following pins must always be connected:

- All VDD and VSS pins (see [Section 2.2 “Power Supply Pins”](#))
- All AVDD and AVSS pins, regardless of whether or not the analog device features are used (see [Section 2.2 “Power Supply Pins”](#))
- MCLR pin (see [Section 2.3 “Master Clear \(MCLR\) Pin”](#))
- ENVREG (if implemented) and VCAP/VDDCORE pins (see [Section 2.4 “Voltage Regulator Pins \(ENVREG and VCAP/VDDCORE\)”](#))

These pins must also be connected if they are being used in the end application:

- PGC/PGD pins used for In-Circuit Serial Programming™ (ICSP™) and debugging purposes (see [Section 2.5 “ICSP Pins”](#))
- OSCI and OSCO pins when an external oscillator source is used (see [Section 2.6 “External Oscillator Pins”](#))

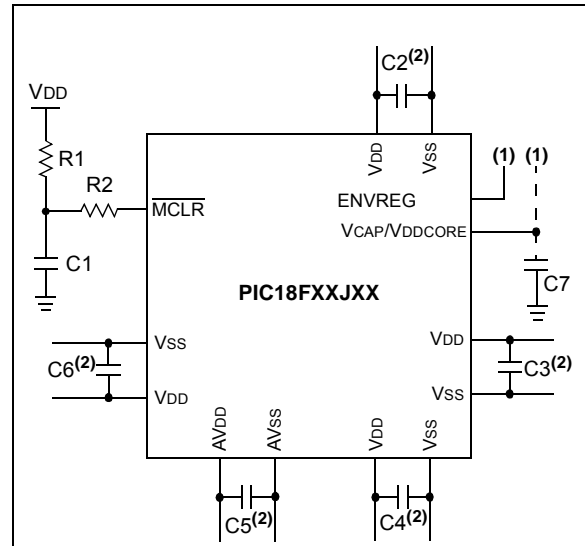
Additionally, the following pins may be required:

- VREF+/VREF- pins are used when external voltage reference for analog modules is implemented

**Note:** The AVDD and AVSS pins must always be connected, regardless of whether any of the analog modules are being used.

The minimum mandatory connections are shown in [Figure 2-1](#).

**FIGURE 2-1: RECOMMENDED MINIMUM CONNECTIONS**



**Key (all values are recommendations):**

C1 through C6: 0.1  $\mu$ F, 20V ceramic

C7: 10  $\mu$ F, 6.3V or greater, tantalum or ceramic

R1: 10 k $\Omega$

R2: 100 $\Omega$  to 470 $\Omega$

- Note 1:** See [Section 2.4 “Voltage Regulator Pins \(ENVREG and VCAP/VDDCORE\)”](#) for explanation of ENVREG pin connections.
- 2:** The example shown is for a PIC18F device with five VDD/VSS and AVDD/AVSS pairs. Other devices may have more or less pairs; adjust the number of decoupling capacitors appropriately.

# PIC18F87J72

## 2.2 Power Supply Pins

### 2.2.1 DECOUPLING CAPACITORS

The use of decoupling capacitors on every pair of power supply pins, such as VDD, VSS, AVDD and AVSS, is required.

Consider the following criteria when using decoupling capacitors:

- **Value and type of capacitor:** A 0.1  $\mu\text{F}$  (100 nF), 10-20V capacitor is recommended. The capacitor should be a low-ESR device, with a resonance frequency in the range of 200 MHz and higher. Ceramic capacitors are recommended.
- **Placement on the printed circuit board:** The decoupling capacitors should be placed as close to the pins as possible. It is recommended to place the capacitors on the same side of the board as the device. If space is constricted, the capacitor can be placed on another layer on the PCB using a via; however, ensure that the trace length from the pin to the capacitor is no greater than 0.25 inch (6 mm).
- **Handling high-frequency noise:** If the board is experiencing high-frequency noise (upward of tens of MHz), add a second ceramic type capacitor in parallel to the above described decoupling capacitor. The value of the second capacitor can be in the range of 0.01  $\mu\text{F}$  to 0.001  $\mu\text{F}$ . Place this second capacitor next to each primary decoupling capacitor. In high-speed circuit designs, consider implementing a decade pair of capacitances as close to the power and ground pins as possible (e.g., 0.1  $\mu\text{F}$  in parallel with 0.001  $\mu\text{F}$ ).
- **Maximizing performance:** On the board layout from the power supply circuit, run the power and return traces to the decoupling capacitors first, and then to the device pins. This ensures that the decoupling capacitors are first in the power chain. Equally important is to keep the trace length between the capacitor and the power pins to a minimum, thereby reducing PCB trace inductance.

### 2.2.2 TANK CAPACITORS

On boards with power traces running longer than six inches in length, it is suggested to use a tank capacitor for integrated circuits, including microcontrollers, to supply a local power source. The value of the tank capacitor should be determined based on the trace resistance that connects the power supply source to the device, and the maximum current drawn by the device in the application. In other words, select the tank capacitor so that it meets the acceptable voltage sag at the device. Typical values range from 4.7  $\mu\text{F}$  to 47  $\mu\text{F}$ .

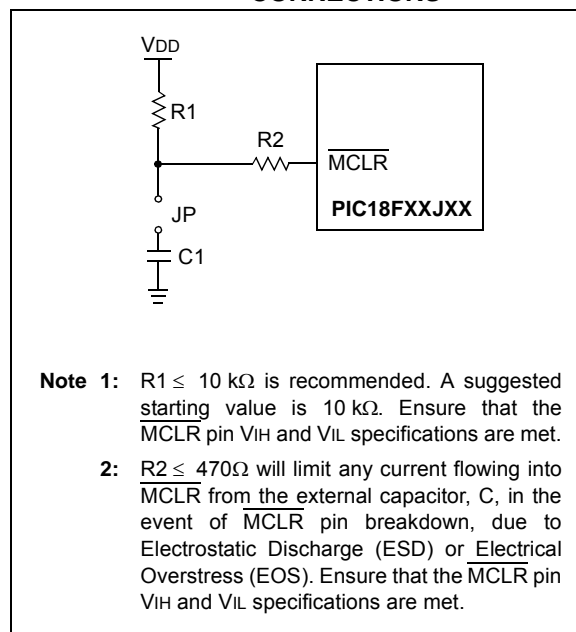
## 2.3 Master Clear ( $\overline{\text{MCLR}}$ ) Pin

The  $\overline{\text{MCLR}}$  pin provides two specific device functions: Device Reset, and Device Programming and Debugging. If programming and debugging are not required in the end application, a direct connection to VDD may be all that is required. The addition of other components, to help increase the application's resistance to spurious Resets from voltage sags, may be beneficial. A typical configuration is shown in Figure 2-1. Other circuit designs may be implemented, depending on the application's requirements.

During programming and debugging, the resistance and capacitance that can be added to the pin must be considered. Device programmers and debuggers drive the  $\overline{\text{MCLR}}$  pin. Consequently, specific voltage levels ( $V_{IH}$  and  $V_{IL}$ ) and fast signal transitions must not be adversely affected. Therefore, specific values of R1 and C1 will need to be adjusted based on the application and PCB requirements. For example, it is recommended that the capacitor, C1, be isolated from the  $\overline{\text{MCLR}}$  pin during programming and debugging operations by using a jumper (Figure 2-2). The jumper is replaced for normal run-time operations.

Any components associated with the  $\overline{\text{MCLR}}$  pin should be placed within 0.25 inch (6 mm) of the pin.

**FIGURE 2-2: EXAMPLE OF  $\overline{\text{MCLR}}$  PIN CONNECTIONS**



## 2.4 Voltage Regulator Pins (ENVREG and VCAP/VDDCORE)

The on-chip voltage regulator enable pin, ENVREG, must always be connected directly to either a supply voltage or to ground. Tying ENVREG to VDD enables the regulator, while tying it to ground disables the regulator. Refer to [Section 26.3 “On-Chip Voltage Regulator”](#) for details on connecting and using the on-chip regulator.

When the regulator is enabled, a low-ESR ( $< 5\Omega$ ) capacitor is required on the VCAP/VDDCORE pin to stabilize the voltage regulator output voltage. The VCAP/VDDCORE pin must not be connected to VDD and must use a capacitor of 10  $\mu\text{F}$  connected to ground. The type can be ceramic or tantalum. A suitable example is the Murata GRM21BF50J106ZE01 (10  $\mu\text{F}$ , 6.3V) or equivalent. Designers may use [Figure 2-3](#) to evaluate ESR equivalence of candidate devices.

It is recommended that the trace length not exceed 0.25 inch (6 mm). Refer to [Section 29.0 “Electrical Characteristics”](#) for additional information.

When the regulator is disabled, the VCAP/VDDCORE pin must be tied to a voltage supply at the VDDCORE level. Refer to [Section 29.0 “Electrical Characteristics”](#) for information on VDD and VDDCORE.

Note that the “LF” versions of some low pin count PIC18FJ parts (e.g., the PIC18LF45J10) do not have the ENVREG pin. These devices are provided with the voltage regulator permanently disabled; they must always be provided with a supply voltage on the VDDCORE pin.

## 2.5 ICSP Pins

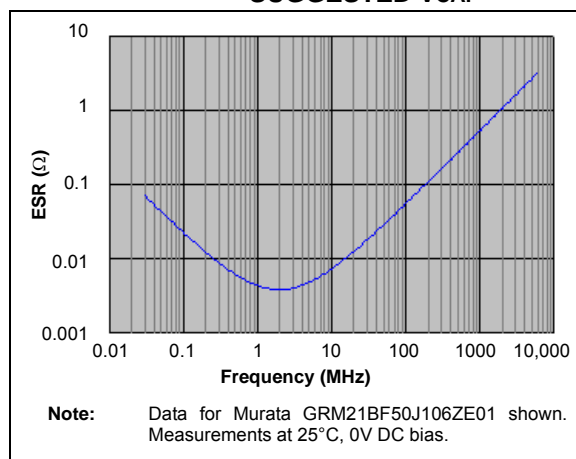
The PGC and PGD pins are used for In-Circuit Serial Programming™ (ICSP™) and debugging purposes. It is recommended to keep the trace length between the ICSP connector and the ICSP pins on the device as short as possible. If the ICSP connector is expected to experience an ESD event, a series resistor is recommended, with the value in the range of a few tens of ohms, not to exceed 100 $\Omega$ .

Pull-up resistors, series diodes, and capacitors on the PGC and PGD pins are not recommended as they will interfere with the programmer/debugger communications to the device. If such discrete components are an application requirement, they should be removed from the circuit during programming and debugging. Alternatively, refer to the AC/DC characteristics and timing requirements information in the respective device Flash programming specification for information on capacitive loading limits, and pin input voltage high ( $V_{IH}$ ) and input low ( $V_{IL}$ ) requirements.

For device emulation, ensure that the “Communication Channel Select” (i.e., PGCx/PGDx pins) programmed into the device matches the physical connections for the ICSP to the Microchip debugger/emulator tool.

For more information on available Microchip development tools connection requirements, refer to [Section 28.0 “Development Support”](#).

**FIGURE 2-3: FREQUENCY vs. ESR PERFORMANCE FOR SUGGESTED VCAP**



## 2.6 External Oscillator Pins

Many microcontrollers have options for at least two oscillators: a high-frequency primary oscillator and a low-frequency secondary oscillator (refer to [Section 3.0 “Oscillator Configurations”](#) for details).

The oscillator circuit should be placed on the same side of the board as the device. Place the oscillator circuit close to the respective oscillator pins with no more than 0.5 inch (12 mm) between the circuit components and the pins. The load capacitors should be placed next to the oscillator itself, on the same side of the board.

Use a grounded copper pour around the oscillator circuit to isolate it from surrounding circuits. The grounded copper pour should be routed directly to the MCU ground. Do not run any signal traces or power traces inside the ground pour. Also, if using a two-sided board, avoid any traces on the other side of the board where the crystal is placed.

Layout suggestions are shown in Figure 2-4. In-line packages may be handled with a single-sided layout that completely encompasses the oscillator pins. With fine-pitch packages, it is not always possible to completely surround the pins and components. A suitable solution is to tie the broken guard sections to a mirrored ground layer. In all cases, the guard trace(s) must be returned to ground.

In planning the application’s routing and I/O assignments, ensure that adjacent port pins and other signals in close proximity to the oscillator are benign (i.e., free of high frequencies, short rise and fall times, and other similar noise).

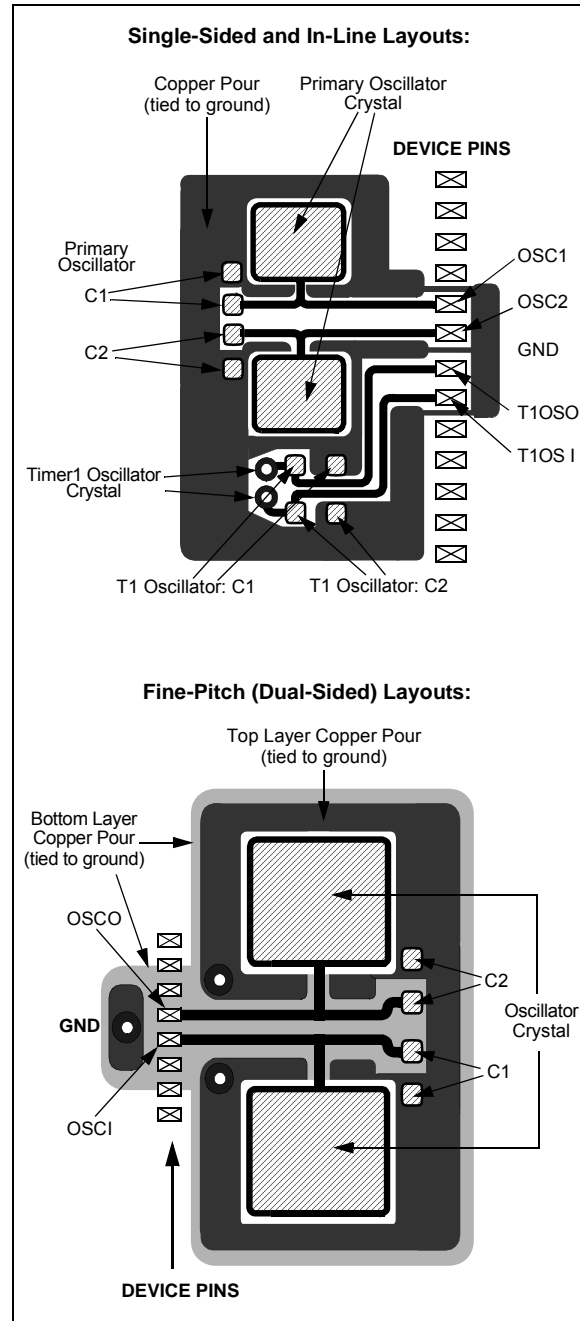
For additional information and design guidance on oscillator circuits, please refer to these Microchip Application Notes, available at the corporate website ([www.microchip.com](http://www.microchip.com)):

- AN826, “Crystal Oscillator Basics and Crystal Selection for rPIC™ and PICmicro® Devices”
- AN849, “Basic PICmicro® Oscillator Design”
- AN943, “Practical PICmicro® Oscillator Analysis and Design”
- AN949, “Making Your Oscillator Work”

## 2.7 Unused I/Os

Unused I/O pins should be configured as outputs and driven to a logic low state. Alternatively, connect a 1 kΩ to 10 kΩ resistor to Vss on unused pins and drive the output to logic low.

**FIGURE 2-4: SUGGESTED PLACEMENT OF THE OSCILLATOR CIRCUIT**



## 3.0 OSCILLATOR CONFIGURATIONS

### 3.1 Oscillator Types

The PIC18F87J72 family of devices can be operated in eight different oscillator modes:

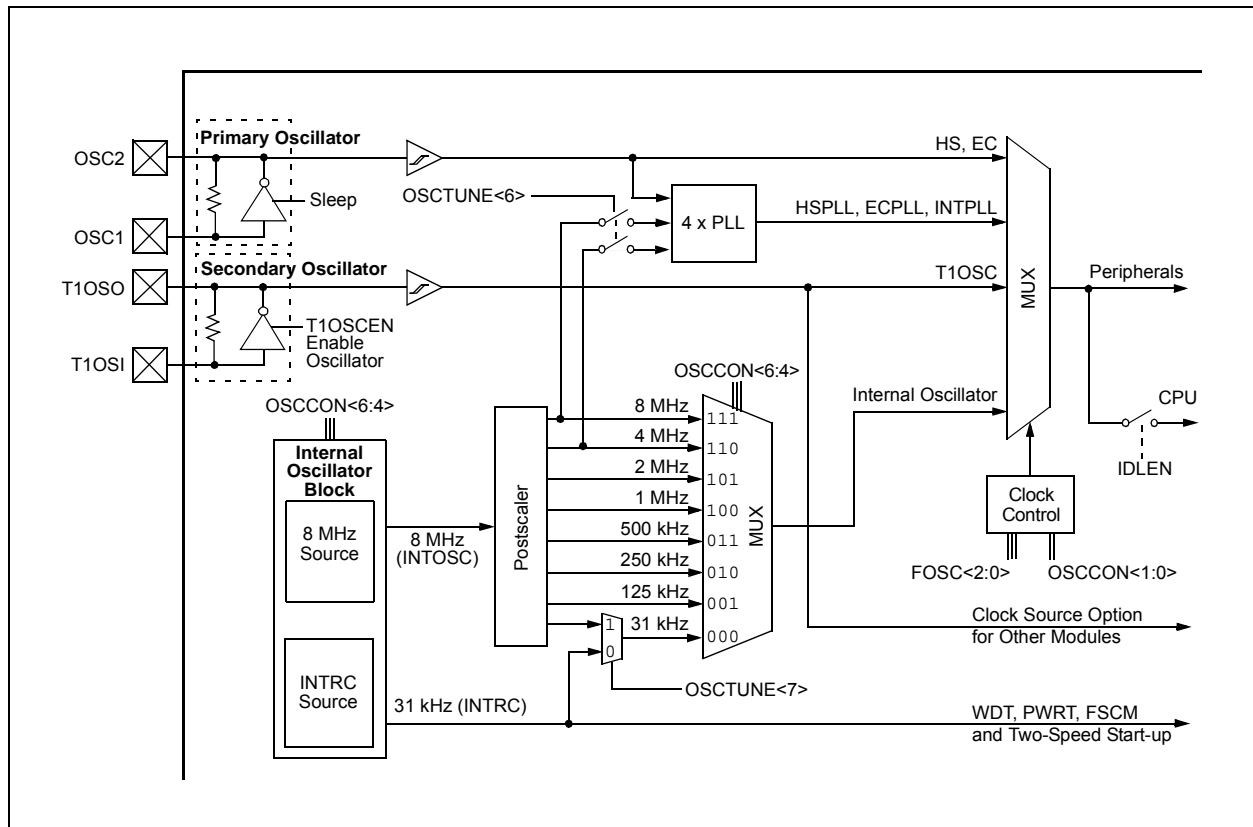
1. ECPLL OSC1/OSC2 as primary; ECPLL oscillator with PLL enabled, CLKO on RA6
2. EC OSC1/OSC2 as primary; external clock with Fosc/4 output
3. HSPLL OSC1/OSC2 as primary; high-speed crystal/resonator with software PLL control
4. HS OSC1/OSC2 as primary; high-speed crystal/resonator
5. INTPLL1 Internal oscillator block with software PLL control, Fosc/4 output on RA6 and I/O on RA7
6. INTIO1 Internal oscillator block with Fosc/4 output on RA6 and I/O on RA7
7. INTPLL2 Internal oscillator block with software PLL control and I/O on RA6 and RA7
8. INTIO2 Internal oscillator block with I/O on RA6 and RA7

All of these modes are selected by the user by programming the FOSC<2:0> Configuration bits.

In addition, PIC18F87J72 family devices can switch between different clock sources, either under software control or automatically under certain conditions. This allows for additional power savings by managing device clock speed in real time without resetting the application.

The clock sources for the PIC18F87J72 family of devices are shown in [Figure 3-1](#).

**FIGURE 3-1: PIC18F87J72 FAMILY CLOCK DIAGRAM**



# PIC18F87J72

## 3.2 Control Registers

The OSCCON register ([Register 3-1](#)) controls the main aspects of the device clock's operation. It selects the oscillator type to be used, which of the power-managed modes to invoke and the output frequency of the INTOSC source. It also provides status on the oscillators.

The OSCTUNE register ([Register 3-2](#)) controls the tuning and operation of the internal oscillator block. It also implements the PLEN bits which control the operation of the Phase-Locked Loop (PLL) (see [Section 3.4.3 "PLL Frequency Multiplier"](#)).

**REGISTER 3-1: OSCCON: OSCILLATOR CONTROL REGISTER<sup>(1)</sup>**

R/W-0	R/W-1	R/W-1	R/W-0	R <sup>(2)</sup>	R-0	R/W-0	R/W-0
IDLEN	IRCF2 <sup>(3)</sup>	IRCF1 <sup>(3)</sup>	IRCF0 <sup>(3)</sup>	OSTS	IOFS	SCS1 <sup>(5)</sup>	SCS0 <sup>(5)</sup>
bit 7							bit 0

Legend:

R = Readable bit

W = Writable bit

U = Unimplemented bit, read as '0'

-n = Value at POR

'1' = Bit is set

'0' = Bit is cleared

x = Bit is unknown

bit 7 **IDLEN:** Idle Enable bit

1 = Device enters an Idle mode when a SLEEP instruction is executed

0 = Device enters Sleep mode when a SLEEP instruction is executed

bit 6-4 **IRCF<2:0>:** INTOSC Source Frequency Select bits<sup>(3)</sup>

111 = 8 MHz (INTOSC drives clock directly)

110 = 4 MHz (default)

101 = 2 MHz

100 = 1 MHz

011 = 500 kHz

010 = 250 kHz

001 = 125 kHz

000 = 31 kHz (from either INTOSC/256 or INTRC)<sup>(4)</sup>

bit 3 **OSTS:** Oscillator Start-up Timer Time-out Status bit<sup>(2)</sup>

1 = Oscillator Start-up Timer (OST) time-out has expired; primary oscillator is running

0 = Oscillator Start-up Timer (OST) time-out is running; primary oscillator is not ready

bit 2 **IOFS:** INTOSC Frequency Stable bit

1 = Fast RC oscillator frequency is stable

0 = Fast RC oscillator frequency is not stable

bit 1-0 **SCS<1:0>:** System Clock Select bits<sup>(5)</sup>

11 = Internal oscillator block

10 = Primary oscillator

01 = Timer1 oscillator

00 = Default primary oscillator (as defined by FOSC<2:0> Configuration bits)

**Note 1:** Default (legacy) SFR at this address; available when WDTCON<4> = 0.

**2:** Reset state depends on the state of the IESO Configuration bit.

**3:** Modifying these bits will cause an immediate clock frequency switch if the internal oscillator is providing the device clocks.

**4:** Source selected by the INTSRC bit (OSCTUNE<7>), see text.

**5:** Modifying these bits will cause an immediate clock source switch.



## REGISTER 3-2: OSCTUNE: OSCILLATOR TUNING REGISTER

R/W-0	R/W-0	R/W-0	R/W-0	R/W-0	R/W-0	R/W-0	R/W-0
INTSRC	PLEN	TUN5	TUN4	TUN3	TUN2	TUN1	TUN0
bit 7							bit 0

### Legend:

R = Readable bit

W = Writable bit

U = Unimplemented bit, read as '0'

-n = Value at POR

'1' = Bit is set

'0' = Bit is cleared

x = Bit is unknown

bit 7	<p><b>INTSRC:</b> Internal Oscillator Low-Frequency Source Select bit</p> <p>1 = 31.25 kHz device clock derived from 8 MHz INTOSC source (divide-by-256 enabled)</p> <p>0 = 31 kHz device clock derived from INTRC 31 kHz oscillator</p>
bit 6	<p><b>PLEN:</b> Frequency Multiplier PLL Enable bit</p> <p>1 = PLL is enabled</p> <p>0 = PLL is disabled</p>
bit 5-0	<p><b>TUN&lt;5:0&gt;:</b> Fast RC Oscillator (INTOSC) Frequency Tuning bits</p> <p>011111 = Maximum frequency</p> <p>. . . . .</p> <p>. . . . .</p> <p>000001</p> <p>000000 = Center frequency. Fast RC oscillator is running at the calibrated frequency.</p> <p>111111</p> <p>. . . . .</p> <p>. . . . .</p> <p>100000 = Minimum frequency</p>

### 3.3 Clock Sources and Oscillator Switching

Essentially, PIC18F87J72 family devices have three independent clock sources:

- Primary oscillators
- Secondary oscillators
- Internal oscillator

The **primary oscillators** can be thought of as the main device oscillators. These are any external oscillators connected to the OSC1 and OSC2 pins, and include the External Crystal and Resonator modes and the External Clock modes. If selected by the FOSC<2:0> Configuration bits, the internal oscillator block (either the 31 kHz INTRC or the 8 MHz INTOSC source) may be considered a primary oscillator. The particular mode is defined by the FOSC Configuration bits. The details of these modes are covered in [Section 3.4 “External Oscillator Modes”](#).

The **secondary oscillators** are external clock sources that are not connected to the OSC1 or OSC2 pins. These sources may continue to operate even after the controller is placed in a power-managed mode. PIC18F87J72 family devices offer the Timer1 oscillator

as a secondary oscillator source. This oscillator, in all power-managed modes, is often the time base for functions such as a Real-Time Clock (RTC). The Timer1 oscillator is discussed in greater detail in [Section 12.0 “Timer1 Module”](#).

In addition to being a primary clock source in some circumstances, the **internal oscillator** is available as a power-managed mode clock source. The INTRC source is also used as the clock source for several special features, such as the WDT and Fail-Safe Clock Monitor. The internal oscillator block is discussed in more detail in [Section 3.5 “Internal Oscillator Block”](#).

The PIC18F87J72 family includes features that allow the device clock source to be switched from the main oscillator, chosen by device configuration, to one of the alternate clock sources. When an alternate clock source is enabled, various power-managed operating modes are available.

# PIC18F87J72

## 3.3.1 CLOCK SOURCE SELECTION

The System Clock Select bits, SCS<1:0> (OSCCON<1:0>), select the clock source. The available clock sources are the primary clock defined by the FOSC<2:0> Configuration bits, the secondary clock (Timer1 oscillator) and the internal oscillator. The clock source changes after one or more of the bits is written to, following a brief clock transition interval.

The OSTS (OSCCON<3>) and T1RUN (T1CON<6>) bits indicate which clock source is currently providing the device clock. The OSTS bit indicates that the Oscillator Start-up Timer (OST) has timed out and the primary clock is providing the device clock in primary clock modes. The T1RUN bit indicates when the Timer1 oscillator is providing the device clock in secondary clock modes. In power-managed modes, only one of these bits will be set at any time. If neither of these bits is set, the INTRC is providing the clock or the internal oscillator has just started and is not yet stable.

The IDLEN bit determines if the device goes into Sleep mode or one of the Idle modes when the SLEEP instruction is executed.

The use of the flag and control bits in the OSCCON register is discussed in more detail in [Section 4.0 “Power-Managed Modes”](#).

**Note 1:** The Timer1 oscillator must be enabled to select the secondary clock source. The Timer1 oscillator is enabled by setting the T1OSCEN bit in the Timer1 Control register (T1CON<3>). If the Timer1 oscillator is not enabled, then any attempt to select a secondary clock source when executing a SLEEP instruction will be ignored.

**2:** It is recommended that the Timer1 oscillator be operating and stable before executing the SLEEP instruction or a very long delay may occur while the Timer1 oscillator starts.

### 3.3.1.1 System Clock Selection and Device Resets

Since the SCS bits are cleared on all forms of Reset, this means the primary oscillator defined by the FOSC<2:0> Configuration bits is used as the primary clock source on device Resets. This could either be the internal oscillator block by itself or one of the other primary clock source (HS, EC, HSPLL, ECPLL1/2 or INTPLL1/2).

In those cases, when the internal oscillator block without PLL, is the default clock on Reset, the Fast RC oscillator (INTOSC) will be used as the device clock source. It will initially start at 1 MHz, which is the postscaler selection that corresponds to the Reset value of the IRCF<2:0> bits ('100').

Regardless of which primary oscillator is selected, INTRC will always be enabled on device power-up. It serves as the clock source until the device has loaded its configuration values from memory. It is at this point that the FOSC Configuration bits are read and the oscillator selection of the operational mode is made.

Note that either the primary clock source, or the internal oscillator, will have two bit setting options for the possible values of the SCS<1:0> bits at any given time.

### 3.3.2 OSCILLATOR TRANSITIONS

PIC18F87J72 family devices contain circuitry to prevent clock “glitches” when switching between clock sources. A short pause in the device clock occurs during the clock switch. The length of this pause is the sum of two cycles of the old clock source and three to four cycles of the new clock source. This formula assumes that the new clock source is stable.

Clock transitions are discussed in greater detail in [Section 4.1.2 “Entering Power-Managed Modes”](#).

## 3.4 External Oscillator Modes

### 3.4.1 CRYSTAL OSCILLATOR/CERAMIC RESONATORS (HS MODES)

In HS or HSPLL Oscillator modes, a crystal or ceramic resonator is connected to the OSC1 and OSC2 pins to establish oscillation. Figure 3-2 shows the pin connections.

The oscillator design requires the use of a crystal rated for parallel resonant operation.

**Note:** Use of a crystal rated for series resonant operation may give a frequency out of the crystal manufacturer's specifications.

**TABLE 3-1: CAPACITOR SELECTION FOR CERAMIC RESONATORS**

Typical Capacitor Values Used:			
Mode	Freq.	OSC1	OSC2
HS	8.0 MHz	27 pF	27 pF
	16.0 MHz	22 pF	22 pF

**Capacitor values are for design guidance only.**

Different capacitor values may be required to produce acceptable oscillator operation. The user should test the performance of the oscillator over the expected VDD and temperature range for the application. Refer to the following application notes for oscillator specific information:

- AN588, "PIC® Microcontroller Oscillator Design Guide"
- AN826, "Crystal Oscillator Basics and Crystal Selection for rPIC® and PIC® Devices"
- AN849, "Basic PIC® Oscillator Design"
- AN943, "Practical PIC® Oscillator Analysis and Design"
- AN949, "Making Your Oscillator Work"

See the notes following Table 3-2 for additional information.

**TABLE 3-2: CAPACITOR SELECTION FOR CRYSTAL OSCILLATOR**

Osc Type	Crystal Freq.	Typical Capacitor Values Tested:	
		C1	C2
HS	4 MHz	27 pF	27 pF
	8 MHz	22 pF	22 pF
	20 MHz	15 pF	15 pF

**Capacitor values are for design guidance only.**

Different capacitor values may be required to produce acceptable oscillator operation. The user should test the performance of the oscillator over the expected VDD and temperature range for the application.

Refer to the Microchip application notes cited in Table 3-1 for oscillator specific information. Also see the notes following this table for additional information.

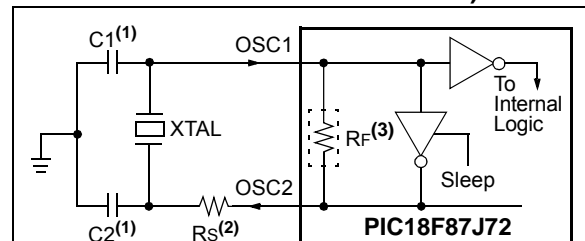
**Note 1:** Higher capacitance increases the stability of oscillator but also increases the start-up time.

**2:** Since each resonator/crystal has its own characteristics, the user should consult the resonator/crystal manufacturer for appropriate values of external components.

**3:** Rs may be required to avoid overdriving crystals with low drive level specification.

**4:** Always verify oscillator performance over the VDD and temperature range that is expected for the application.

**FIGURE 3-2: CRYSTAL/CERAMIC RESONATOR OPERATION (HS OR HSPLL CONFIGURATION)**



**Note 1:** See Table 3-1 and Table 3-2 for initial values of C1 and C2.

**2:** A series resistor (Rs) may be required for AT strip cut crystals.

**3:** Rf varies with the oscillator mode chosen.

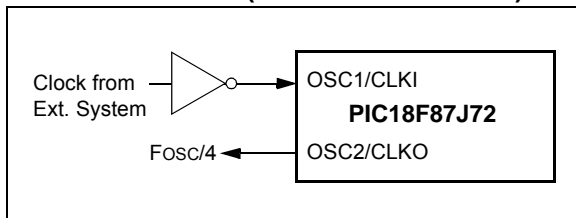
# PIC18F87J72

## 3.4.2 EXTERNAL CLOCK INPUT (EC MODES)

The EC and ECPLL Oscillator modes require an external clock source to be connected to the OSC1 pin. There is no oscillator start-up time required after a Power-on Reset or after an exit from Sleep mode.

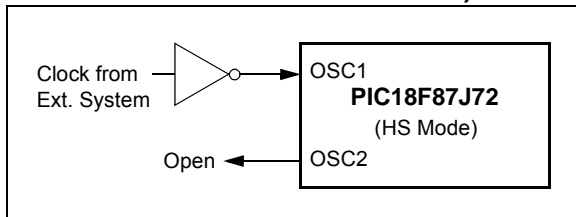
In the EC Oscillator mode, the oscillator frequency divided by 4 is available on the OSC2 pin. This signal may be used for test purposes or to synchronize other logic. [Figure 3-3](#) shows the pin connections for the EC Oscillator mode.

**FIGURE 3-3: EXTERNAL CLOCK INPUT OPERATION (EC CONFIGURATION)**



An external clock source may also be connected to the OSC1 pin in the HS mode, as shown in [Figure 3-4](#). In this configuration, the divide-by-4 output on OSC2 is not available. Current consumption in this configuration will be somewhat higher than EC mode, as the internal oscillator's feedback circuitry will be enabled (in EC mode, the feedback circuit is disabled).

**FIGURE 3-4: EXTERNAL CLOCK INPUT OPERATION (HS OSC CONFIGURATION)**



## 3.4.3 PLL FREQUENCY MULTIPLIER

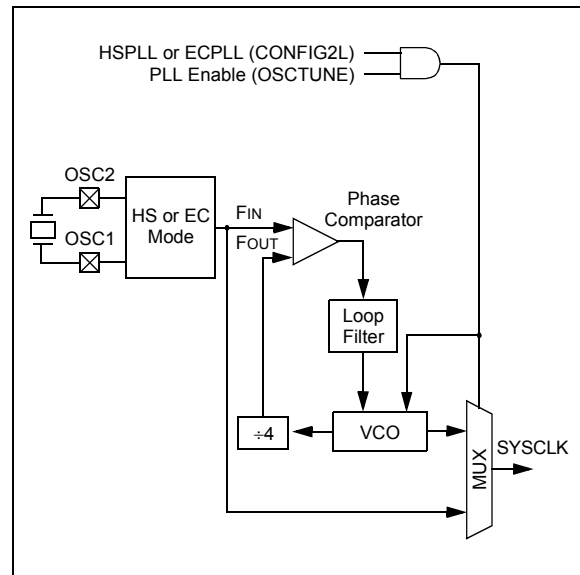
A Phase-Locked Loop (PLL) circuit is provided as an option for users who want to use a lower frequency oscillator circuit, or to clock the device up to its highest rated frequency from a crystal oscillator. This may be useful for customers who are concerned with EMI due to high-frequency crystals, or users who require higher clock speeds from an internal oscillator.

### 3.4.3.1 HSPLL and ECPLL Modes

The HSPLL and ECPLL modes provide the ability to selectively run the device at four times the external oscillating source to produce frequencies up to 40 MHz.

The PLL is enabled by programming the FOSC<2:0> Configuration bits to either '111' (for ECPLL) or '101' (for HSPLL). In addition, the PLEN bit (OSCTUNE<6>) must also be set. Clearing PLEN disables the PLL, regardless of the chosen oscillator configuration. It also allows additional flexibility for controlling the application's clock speed in software.

**FIGURE 3-5: PLL BLOCK DIAGRAM**



### 3.4.3.2 PLL and INTOSC

The PLL is also available to the internal oscillator block when the internal oscillator block is configured as the primary clock source. In this configuration, the PLL is enabled in software and generates a clock output of up to 32 MHz. The operation of INTOSC with the PLL is described in [Section 3.5.2 "INTPLL Modes"](#).

## 3.5 Internal Oscillator Block

The PIC18F87J72 family of devices includes an internal oscillator block which generates two different clock signals; either can be used as the microcontroller's clock source. This may eliminate the need for an external oscillator circuit on the OSC1 and/or OSC2 pins.

The main output is the Fast RC oscillator, or INTOSC, an 8 MHz clock source which can be used to directly drive the device clock. It also drives a postscaler, which can provide a range of clock frequencies from 31 kHz to 4 MHz. INTOSC is enabled when a clock frequency from 125 kHz to 8 MHz is selected. The INTOSC output can also be enabled when 31 kHz is selected, depending on the INTSRC bit (OSCTUNE<7>).

The other clock source is the Internal RC (INTRC) oscillator, which provides a nominal 31 kHz output. INTRC is enabled if it is selected as the device clock source. It is also enabled automatically when any of the following are enabled:

- Power-up Timer
- Fail-Safe Clock Monitor
- Watchdog Timer
- Two-Speed Start-up

These features are discussed in greater detail in [Section 26.0 "Special Features of the CPU"](#).

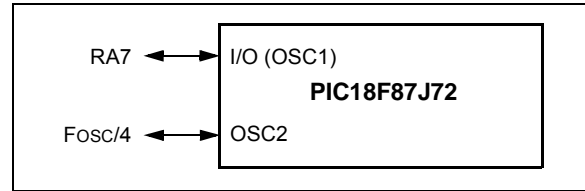
The clock source frequency (INTOSC direct, INTOSC with postscaler or INTRC direct) is selected by configuring the IRCF bits of the OSCCON register. The default frequency on device Resets is 4 MHz.

### 3.5.1 INTIO MODES

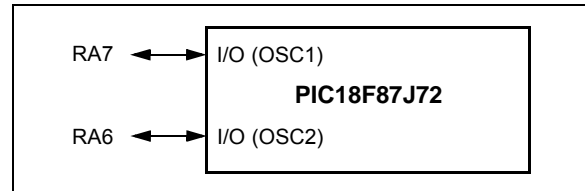
Using the internal oscillator as the clock source eliminates the need for up to two external oscillator pins, which can then be used for digital I/O. Two distinct oscillator configurations, which are determined by the FOSC Configuration bits, are available:

- In INTIO1 mode, the OSC2 pin outputs  $F_{osc}/4$  while OSC1 functions as RA7 (see [Figure 3-6](#)) for digital input and output.
- In INTIO2 mode, OSC1 functions as RA7 and OSC2 functions as RA6 (see [Figure 3-7](#)), both for digital input and output.

**FIGURE 3-6: INTIO1 OSCILLATOR MODE**



**FIGURE 3-7: INTIO2 OSCILLATOR MODE**



### 3.5.2 INTPLL MODES

The 4x Phase-Locked Loop (PLL) can be used with the internal oscillator block to produce faster device clock speeds than are normally possible with the internal oscillator sources. When enabled, the PLL produces a clock speed of 16 MHz or 32 MHz.

PLL operation is controlled through software. The control bit, PLEN (OSCTUNE<6>), is used to enable or disable its operation. The PLL is available only to INTOSC when the device is configured to use one of the INTPLL modes as the primary clock source (FOSC<2:0> = 011 or 001). Additionally, the PLL will only function when the selected output frequency is either 4 MHz or 8 MHz (OSCCON<6:4> = 111 or 110).

Like the INTIO modes, there are two distinct INTPLL modes available:

- In INTPLL1 mode, the OSC2 pin outputs  $F_{osc}/4$ , while OSC1 functions as RA7 for digital input and output. Externally, this is identical in appearance to INTIO1 ([Figure 3-6](#)).
- In INTPLL2 mode, OSC1 functions as RA7 and OSC2 functions as RA6, both for digital input and output. Externally, this is identical to INTIO2 ([Figure 3-7](#)).

## 3.5.3 INTERNAL OSCILLATOR OUTPUT FREQUENCY AND TUNING

The internal oscillator block is calibrated at the factory to produce an INTOSC output frequency of 8 MHz. It can be adjusted in the user's application by writing to TUN<5:0> (OSCTUNE<5:0>) in the OSCTUNE register ([Register 3-2](#)).

When the OSCTUNE register is modified, the INTOSC frequency will begin shifting to the new frequency. The oscillator will stabilize within 1 ms. Code execution continues during this shift and there is no indication that the shift has occurred.

The INTRC oscillator operates independently of the INTOSC source. Any changes in INTOSC across voltage and temperature are not necessarily reflected by changes in INTRC or vice versa. The frequency of INTRC is not affected by OSCTUNE.

## 3.5.4 INTOSC FREQUENCY DRIFT

The INTOSC frequency may drift as V<sub>DD</sub> or temperature changes and can affect the controller operation in a variety of ways. It is possible to adjust the INTOSC frequency by modifying the value in the OSCTUNE register. Depending on the device, this may have no effect on the INTRC clock source frequency.

Tuning INTOSC requires knowing when to make the adjustment, in which direction it should be made, and in some cases, how large a change is needed. Three compensation techniques are shown here.

### 3.5.4.1 Compensating with the EUSART

An adjustment may be required when the EUSART begins to generate framing errors or receives data with errors while in Asynchronous mode. Framing errors indicate that the device clock frequency is too high. To adjust for this, decrement the value in OSCTUNE to reduce the clock frequency. On the other hand, errors in data may suggest that the clock speed is too low. To compensate, increment OSCTUNE to increase the clock frequency.

### 3.5.4.2 Compensating with the Timers

This technique compares device clock speed to some reference clock. Two timers may be used; one timer is clocked by the peripheral clock, while the other is clocked by a fixed reference source, such as the Timer1 oscillator.

Both timers are cleared, but the timer clocked by the reference generates interrupts. When an interrupt occurs, the internally clocked timer is read and both timers are cleared. If the internally clocked timer value is much greater than expected, then the internal oscillator block is running too fast. To adjust for this, decrement the OSCTUNE register.

### 3.5.4.3 Compensating with the CCP Module in Capture Mode

A CCP module can use free-running Timer1 (or Timer3), clocked by the internal oscillator block and an external event with a known period (i.e., AC power frequency). The time of the first event is captured in the CCPRxH:CCPRxL registers and is recorded for use later. When the second event causes a capture, the time of the first event is subtracted from the time of the second event. Since the period of the external event is known, the time difference between events can be calculated.

If the measured time is much greater than the calculated time, the internal oscillator block is running too fast. To compensate, decrement the OSCTUNE register. If the measured time is much less than the calculated time, the internal oscillator block is running too slow. To compensate, increment the OSCTUNE register.

## 3.6 Effects of Power-Managed Modes on the Various Clock Sources

When PRI\_IDLE mode is selected, the designated primary oscillator continues to run without interruption. For all other power-managed modes, the oscillator using the OSC1 pin is disabled. The OSC1 pin (and OSC2 pin if used by the oscillator) will stop oscillating.

In secondary clock modes (SEC\_RUN and SEC\_IDLE), the Timer1 oscillator is operating and providing the device clock. The Timer1 oscillator may also run in all power-managed modes if required to clock Timer1 or Timer3.

In RC\_RUN and RC\_IDLE modes, the internal oscillator provides the device clock source. The 31 kHz INTRC output can be used directly to provide the clock and may be enabled to support various special features, regardless of the power-managed mode (see [Section 26.2 “Watchdog Timer \(WDT\)”](#) through [Section 26.5 “Fail-Safe Clock Monitor”](#) for more information on WDT, Fail-Safe Clock Monitor and Two-Speed Start-up).

If the Sleep mode is selected, all clock sources are stopped. Since all the transistor switching currents have been stopped, Sleep mode achieves the lowest current consumption of the device (only leakage currents).

Enabling any on-chip feature that will operate during Sleep will increase the current consumed during Sleep. The INTRC is required to support WDT operation. The Timer1 oscillator may be operating to support a Real-Time Clock (RTC). Other features may be operating that do not require a device clock source (i.e., MSSP slave, INTx pins and others).

Peripherals that may add significant current consumption are listed in [Section 29.1 “DC Characteristics: Power-Down and Supply Current PIC18F87J72 Family \(Industrial\)”](#).

## 3.7 Power-up Delays

Power-up delays are controlled by two timers, so that no external Reset circuitry is required for most applications. The delays ensure that the device is kept in Reset until the device power supply is stable under normal circumstances, and the primary clock is operating and stable. For additional information on power-up delays, see [Section 5.6 “Power-up Timer \(PWRT\)”](#).

The first timer is the Power-up Timer (PWRT), which provides a fixed delay on power-up (parameter 33, [Table 29-2](#)); it is always enabled.

The second timer is the Oscillator Start-up Timer (OST), intended to keep the chip in Reset until the crystal oscillator is stable (HS modes). The OST does this by counting 1024 oscillator cycles before allowing the oscillator to clock the device.

There is a delay of interval, TcSD (parameter 38, [Table 29-2](#)), following POR, while the controller becomes ready to execute instructions.

**TABLE 3-3: OSC1 AND OSC2 PIN STATES IN SLEEP MODE**

Oscillator Mode	OSC1 Pin	OSC2 Pin
EC, ECPLL	Floating, pulled by external clock	At logic low (clock/4 output)
HS, HSPLL	Feedback inverter disabled at quiescent voltage level	Feedback inverter disabled at quiescent voltage level
INTOSC, INTPLL1/2	I/O pin, RA6, direction controlled by TRISA<6>	I/O pin, RA6, direction controlled by TRISA<7>

**Note:** See [Section 5.0 “Reset”](#) for time-outs due to Sleep and MCLR Reset.

# PIC18F87J72

## 4.0 POWER-MANAGED MODES

The PIC18F87J72 family devices provide the ability to manage power consumption by simply managing clocking to the CPU and the peripherals. In general, a lower clock frequency and a reduction in the number of circuits being clocked constitutes lower consumed power. For the sake of managing power in an application, there are three primary modes of operation:

- Run mode
- Idle mode
- Sleep mode

These modes define which portions of the device are clocked and at what speed. The Run and Idle modes may use any of the three available clock sources (primary, secondary or internal oscillator block); the Sleep mode does not use a clock source.

The power-managed modes include several power-saving features offered on previous PIC® devices. One is the clock switching feature, offered in other PIC18 devices, allowing the controller to use the Timer1 oscillator in place of the primary oscillator. Also included is the Sleep mode, offered by all PIC devices, where all device clocks are stopped.

### 4.1 Selecting Power-Managed Modes

Selecting a power-managed mode requires two decisions: if the CPU is to be clocked or not and which clock source is to be used. The IDLEN bit (OSCCON<7>) controls CPU clocking, while the SCS<1:0> bits (OSCCON<1:0>) select the clock source. The individual modes, bit settings, clock sources and affected modules are summarized in [Table 4-1](#).

TABLE 4-1: POWER-MANAGED MODES

Mode	OSCCON Bits		Module Clocking		Available Clock and Oscillator Source
	IDLEN<7> <sup>(1)</sup>	SCS<1:0>	CPU	Peripherals	
Sleep	0	N/A	Off	Off	None – All clocks are disabled
PRI_RUN	N/A	10	Clocked	Clocked	Primary – HS, EC, HSPLL, ECPLL; this is the normal full-power execution mode
SEC_RUN	N/A	01	Clocked	Clocked	Secondary – Timer1 Oscillator
RC_RUN	N/A	11	Clocked	Clocked	Internal Oscillator
PRI_IDLE	1	10	Off	Clocked	Primary – HS, EC, HSPLL, ECPLL
SEC_IDLE	1	01	Off	Clocked	Secondary – Timer1 Oscillator
RC_IDLE	1	11	Off	Clocked	Internal Oscillator

**Note 1:** IDLEN reflects its value when the SLEEP instruction is executed.

### 4.1.1 CLOCK SOURCES

The SCS<1:0> bits allow the selection of one of three clock sources for power-managed modes. They are:

- the primary clock, as defined by the FOSC<2:0> Configuration bits
- the secondary clock (Timer1 oscillator)
- the internal oscillator

### 4.1.2 ENTERING POWER-MANAGED MODES

Switching from one power-managed mode to another begins by loading the OSCCON register. The SCS<1:0> bits select the clock source and determine which Run or Idle mode is to be used. Changing these bits causes an immediate switch to the new clock source, assuming that it is running. The switch may also be subject to clock transition delays. These are discussed in [Section 4.1.3 “Clock Transitions and Status Indicators”](#) and subsequent sections.

Entry to the power-managed Idle or Sleep modes is triggered by the execution of a SLEEP instruction. The actual mode that results depends on the status of the IDLEN bit.

Depending on the current mode and the mode being switched to, a change to a power-managed mode does not always require setting all of these bits. Many transitions may be done by changing the oscillator select bits, or changing the IDLEN bit, prior to issuing a SLEEP instruction. If the IDLEN bit is already configured correctly, it may only be necessary to perform a SLEEP instruction to switch to the desired mode.



## 4.1.3 CLOCK TRANSITIONS AND STATUS INDICATORS

The length of the transition between clock sources is the sum of two cycles of the old clock source and three to four cycles of the new clock source. This formula assumes that the new clock source is stable.

Two bits indicate the current clock source and its status: OSTS (OSCCON<3>) and T1RUN (T1CON<6>). In general, only one of these bits will be set while in a given power-managed mode. When the OSTS bit is set, the primary clock is providing the device clock. When the T1RUN bit is set, the Timer1 oscillator is providing the clock. If neither of these bits is set, INTRC is clocking the device.

**Note:** Executing a `SLEEP` instruction does not necessarily place the device into Sleep mode. It acts as the trigger to place the controller into either the Sleep mode, or one of the Idle modes, depending on the setting of the IDLEN bit.

## 4.1.4 MULTIPLE SLEEP COMMANDS

The power-managed mode that is invoked with the `SLEEP` instruction is determined by the setting of the IDLEN bit at the time the instruction is executed. If another `SLEEP` instruction is executed, the device will enter the power-managed mode specified by IDLEN at that time. If IDLEN has changed, the device will enter the new power-managed mode specified by the new setting.

## 4.2 Run Modes

In the Run modes, clocks to both the core and peripherals are active. The difference between these modes is the clock source.

### 4.2.1 PRI\_RUN MODE

The PRI\_RUN mode is the normal, full-power execution mode of the microcontroller. This is also the default mode upon a device Reset unless Two-Speed Start-up is enabled (see [Section 26.4 “Two-Speed Start-up”](#) for details). In this mode, the OSTS bit is set (see [Section 3.2 “Control Registers”](#)).

### 4.2.2 SEC\_RUN MODE

The SEC\_RUN mode is the compatible mode to the “clock switching” feature offered in other PIC18 devices. In this mode, the CPU and peripherals are clocked from the Timer1 oscillator. This gives users the option of lower power consumption while still using a high-accuracy clock source.

SEC\_RUN mode is entered by setting the SCS<1:0> bits to ‘01’. The device clock source is switched to the Timer1 oscillator (see [Figure 4-1](#)), the primary oscillator is shut down, the T1RUN bit (T1CON<6>) is set and the OSTS bit is cleared.

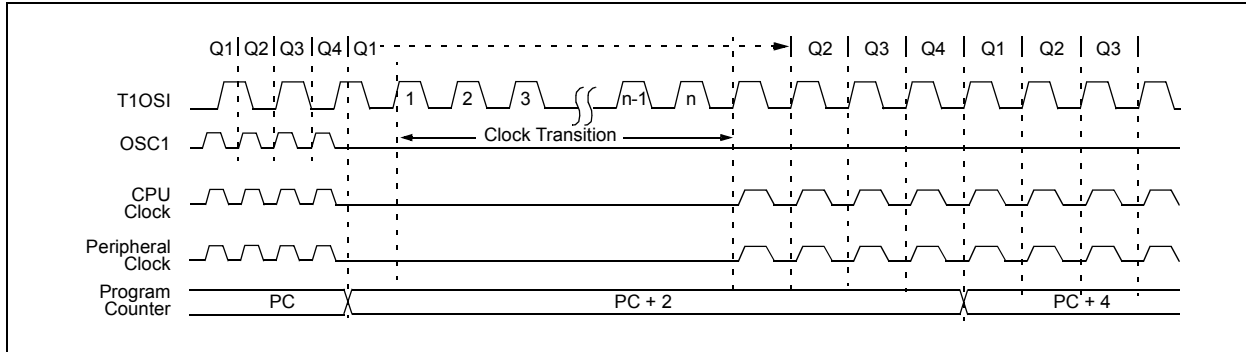
**Note:** The Timer1 oscillator should already be running prior to entering SEC\_RUN mode. If the T1OSCEN bit is not set when the SCS<1:0> bits are set to ‘01’, entry to SEC\_RUN mode will not occur. If the Timer1 oscillator is enabled, but not yet running, device clocks will be delayed until the oscillator has started. In such situations, initial oscillator operation is far from stable and unpredictable operation may result.

# PIC18F87J72

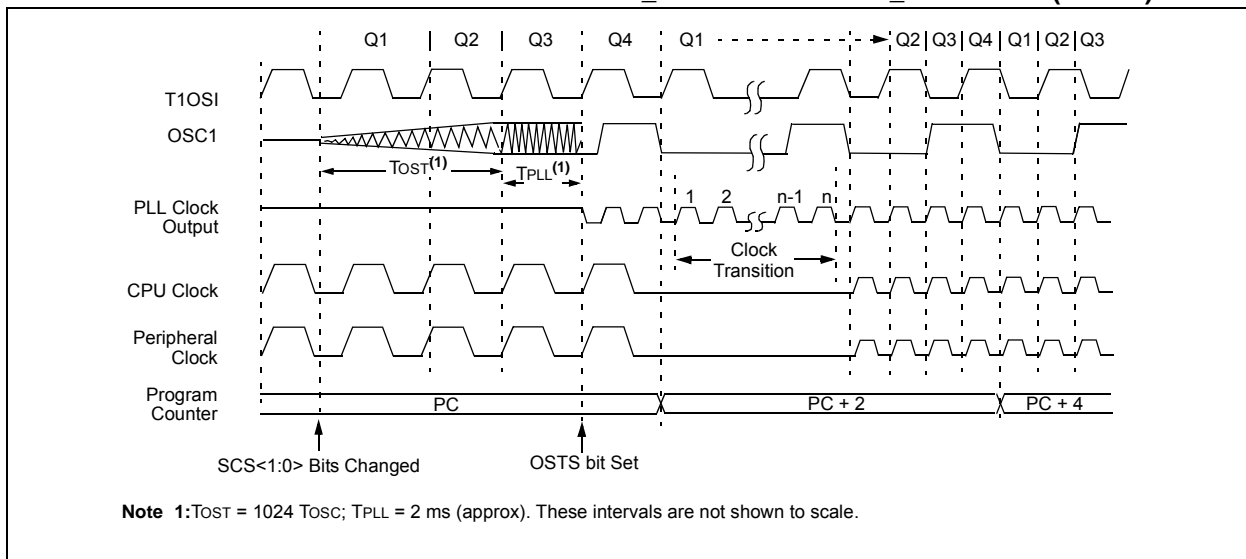
On transitions from SEC\_RUN mode to PRI\_RUN mode, the peripherals and CPU continue to be clocked from the Timer1 oscillator while the primary clock is started. When the primary clock becomes ready, a clock switch back to the primary clock occurs (see

Figure 4-2). When the clock switch is complete, the T1RUN bit is cleared, the OSTS bit is set and the primary clock is providing the clock. The IDLEN and SCS bits are not affected by the wake-up; the Timer1 oscillator continues to run.

**FIGURE 4-1: TRANSITION TIMING FOR ENTRY TO SEC\_RUN MODE**



**FIGURE 4-2: TRANSITION TIMING FROM SEC\_RUN MODE TO PRI\_RUN MODE (HSPLL)**



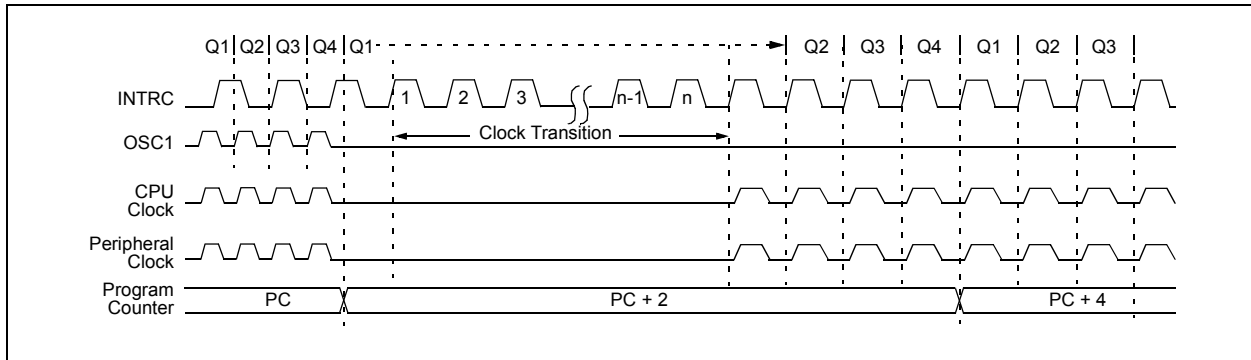
## 4.2.3 RC\_RUN MODE

In RC\_RUN mode, the CPU and peripherals are clocked from the internal oscillator; the primary clock is shut down. This mode provides the best power conservation of all the Run modes while still executing code. It works well for user applications which are not highly timing-sensitive or do not require high-speed clocks at all times.

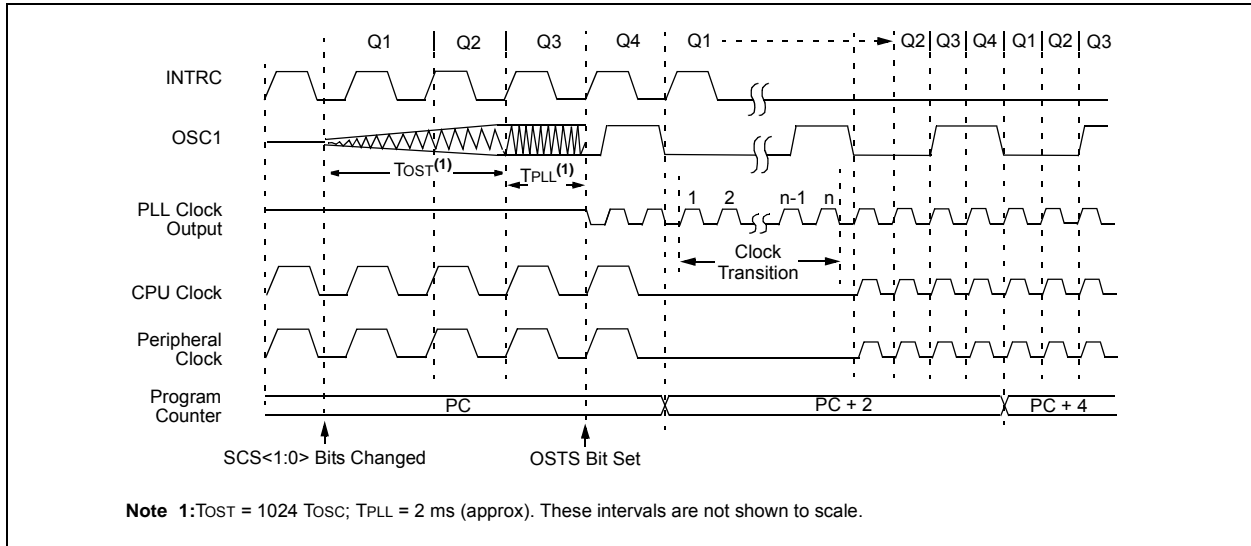
This mode is entered by setting SCS bits to '11'. When the clock source is switched to the INTRC (see Figure 4-3), the primary oscillator is shut down and the OSTS bit is cleared.

On transitions from RC\_RUN mode to PRI\_RUN mode, the device continues to be clocked from the INTRC while the primary clock is started. When the primary clock becomes ready, a clock switch to the primary clock occurs (see Figure 4-4). When the clock switch is complete, the OSTS bit is set and the primary clock is providing the device clock. The IDLEN and SCS bits are not affected by the switch. The INTRC source will continue to run if either the WDT or the Fail-Safe Clock Monitor is enabled.

**FIGURE 4-3: TRANSITION TIMING TO RC\_RUN MODE**



**FIGURE 4-4: TRANSITION TIMING FROM RC\_RUN MODE TO PRI\_RUN MODE**



# PIC18F87J72

## 4.3 Sleep Mode

The power-managed Sleep mode is identical to the legacy Sleep mode offered in all other PIC devices. It is entered by clearing the IDLEN bit (the default state on device Reset) and executing the `SLEEP` instruction. This shuts down the selected oscillator (Figure 4-5). All clock source Status bits are cleared.

Entering the Sleep mode from any other mode does not require a clock switch. This is because no clocks are needed once the controller has entered Sleep. If the WDT is selected, the INTRC source will continue to operate. If the Timer1 oscillator is enabled, it will also continue to run.

When a wake event occurs in Sleep mode (by interrupt, Reset or WDT time-out), the device will not be clocked until the clock source selected by the `SCS<1:0>` bits becomes ready (see Figure 4-6), or it will be clocked from the internal oscillator if either the Two-Speed Start-up or the Fail-Safe Clock Monitor is enabled (see Section 26.0 “Special Features of the CPU”). In either case, the OSTS bit is set when the primary clock is providing the device clocks. The IDLEN and `SCS` bits are not affected by the wake-up.

## 4.4 Idle Modes

The Idle modes allow the controller’s CPU to be selectively shut down while the peripherals continue to operate. Selecting a particular Idle mode allows users to further manage power consumption.

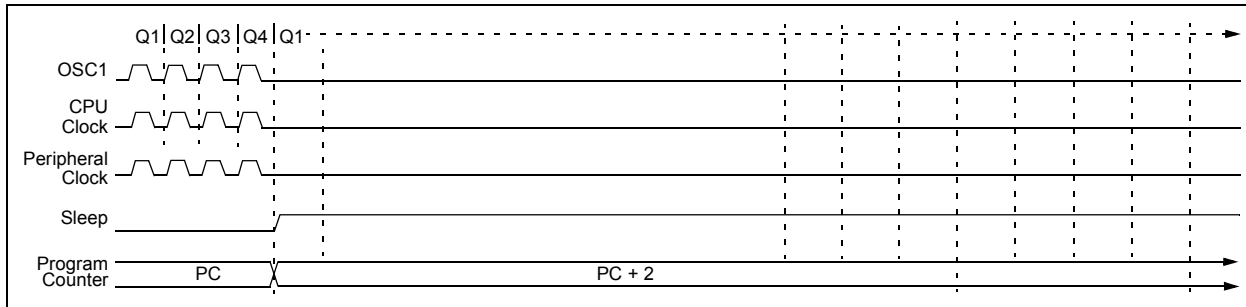
If the IDLEN bit is set to a ‘1’ when a `SLEEP` instruction is executed, the peripherals will be clocked from the clock source selected using the `SCS<1:0>` bits; however, the CPU will not be clocked. The clock source Status bits are not affected. Setting IDLEN and executing a `SLEEP` instruction provides a quick method of switching from a given Run mode to its corresponding Idle mode.

If the WDT is selected, the INTRC source will continue to operate. If the Timer1 oscillator is enabled, it will also continue to run.

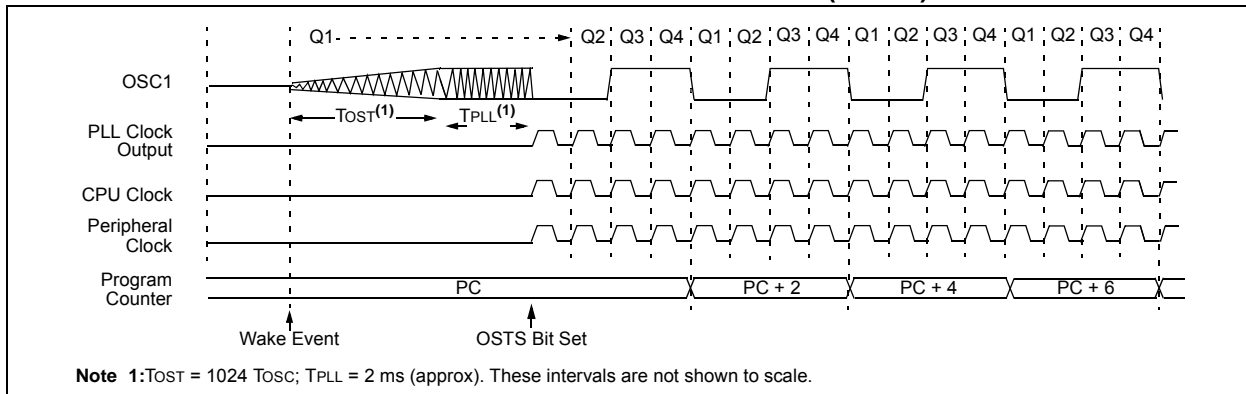
Since the CPU is not executing instructions, the only exits from any of the Idle modes are by interrupt, WDT time-out or a Reset. When a wake event occurs, CPU execution is delayed by an interval of `TCSD` (parameter 38, Table 29-2) while it becomes ready to execute code. When the CPU begins executing code, it resumes with the same clock source for the current Idle mode. For example, when waking from `RC_IDLE` mode, the internal oscillator block will clock the CPU and peripherals (in other words, `RC_RUN` mode). The IDLEN and `SCS` bits are not affected by the wake-up.

While in any Idle mode or the Sleep mode, a WDT time-out will result in a WDT wake-up to the Run mode currently specified by the `SCS<1:0>` bits.

**FIGURE 4-5: TRANSITION TIMING FOR ENTRY TO SLEEP MODE**



**FIGURE 4-6: TRANSITION TIMING FOR WAKE FROM SLEEP (HSPLL)**



## 4.4.1 PRI\_IDLE MODE

This mode is unique among the three low-power Idle modes, in that it does not disable the primary device clock. For timing-sensitive applications, this allows for the fastest resumption of device operation with its more accurate primary clock source, since the clock source does not have to “warm up” or transition from another oscillator.

PRI\_IDLE mode is entered from PRI\_RUN mode by setting the IDLEN bit and executing a SLEEP instruction. If the device is in another Run mode, set IDLEN first, then set the SCS bits to ‘10’ and execute SLEEP. Although the CPU is disabled, the peripherals continue to be clocked from the primary clock source specified by the FOSC<1:0> Configuration bits. The OSTS bit remains set (see Figure 4-7).

When a wake event occurs, the CPU is clocked from the primary clock source. A delay of interval, TCSD, is required between the wake event and when code execution starts. This is required to allow the CPU to become ready to execute instructions. After the wake-up, the OSTS bit remains set. The IDLEN and SCS bits are not affected by the wake-up (see Figure 4-8).

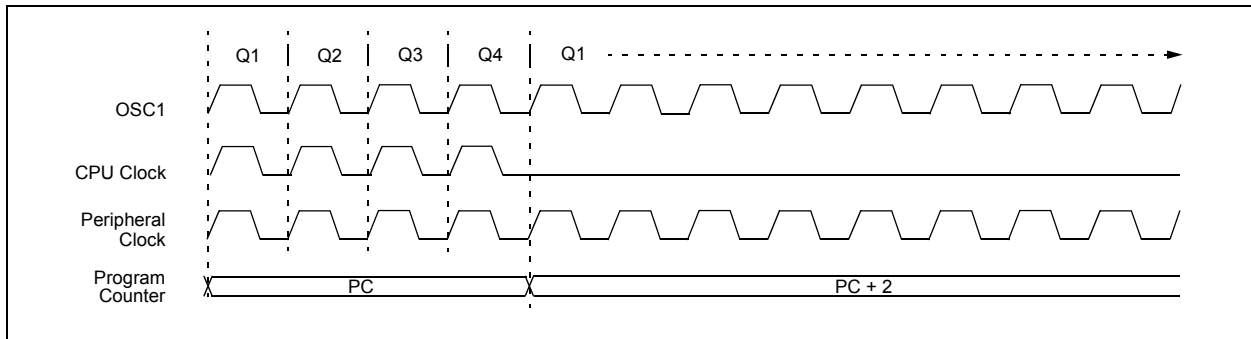
## 4.4.2 SEC\_IDLE MODE

In SEC\_IDLE mode, the CPU is disabled but the peripherals continue to be clocked from the Timer1 oscillator. This mode is entered from SEC\_RUN by setting the IDLEN bit and executing a SLEEP instruction. If the device is in another Run mode, set IDLEN first, then set SCS<1:0> to ‘01’ and execute SLEEP. When the clock source is switched to the Timer1 oscillator, the primary oscillator is shut down, the OSTS bit is cleared and the T1RUN bit is set.

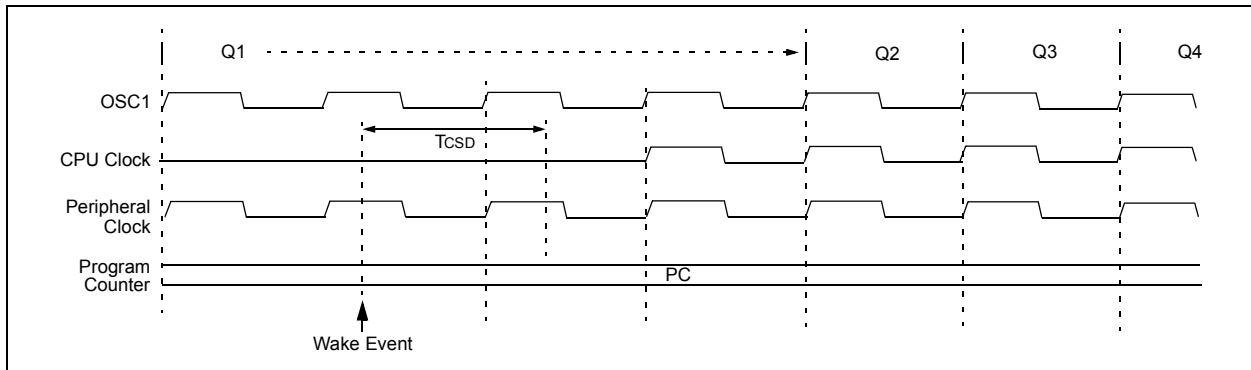
When a wake event occurs, the peripherals continue to be clocked from the Timer1 oscillator. After an interval of TCSD, following the wake event, the CPU begins executing code being clocked by the Timer1 oscillator. The IDLEN and SCS bits are not affected by the wake-up; the Timer1 oscillator continues to run (see Figure 4-8).

**Note:** The Timer1 oscillator should already be running prior to entering SEC\_IDLE mode. If the T1OSCEN bit is not set when the SLEEP instruction is executed, the SLEEP instruction will be ignored and entry to SEC\_IDLE mode will not occur. If the Timer1 oscillator is enabled, but not yet running, peripheral clocks will be delayed until the oscillator has started. In such situations, initial oscillator operation is far from stable and unpredictable operation may result.

**FIGURE 4-7: TRANSITION TIMING FOR ENTRY TO IDLE MODE**



**FIGURE 4-8: TRANSITION TIMING FOR WAKE FROM IDLE TO RUN MODE**



# PIC18F87J72

---

## 4.4.3 RC\_IDLE MODE

In RC\_IDLE mode, the CPU is disabled but the peripherals continue to be clocked from the internal oscillator. This mode allows for controllable power conservation during Idle periods.

From RC\_RUN, this mode is entered by setting the IDLEN bit and executing a SLEEP instruction. If the device is in another Run mode, first set IDLEN, then clear the SCS bits and execute SLEEP. When the clock source is switched to the INTRC, the primary oscillator is shut down and the OSTC bit is cleared.

When a wake event occurs, the peripherals continue to be clocked from the INTOSC. After a delay of T<sub>CSD</sub>, following the wake event, the CPU begins executing code being clocked by the INTOSC. The IDLEN and SCS bits are not affected by the wake-up. The INTOSC source will continue to run if either the WDT or the Fail-Safe Clock Monitor is enabled.

## 4.5 Exiting Idle and Sleep Modes

An exit from Sleep mode, or any of the Idle modes, is triggered by an interrupt, a Reset or a WDT time-out. This section discusses the triggers that cause exits from power-managed modes. The clocking subsystem actions are discussed in each of the power-managed mode sections (see [Section 4.2 “Run Modes”](#), [Section 4.3 “Sleep Mode”](#) and [Section 4.4 “Idle Modes”](#)).

### 4.5.1 EXIT BY INTERRUPT

Any of the available interrupt sources can cause the device to exit from an Idle mode, or the Sleep mode, to a Run mode. To enable this functionality, an interrupt source must be enabled by setting its enable bit in one of the INTCON or PIE registers. The exit sequence is initiated when the corresponding interrupt flag bit is set.

On all exits from Idle or Sleep modes, by interrupt, code execution branches to the interrupt vector if the GIE/GIEH bit (INTCON<7>) is set. Otherwise, code execution continues or resumes without branching (see [Section 9.0 “Interrupts”](#)).

A fixed delay of interval, T<sub>CSD</sub>, following the wake event is required when leaving Sleep and Idle modes. This delay is required for the CPU to prepare for execution. Instruction execution resumes on the first clock cycle following this delay.

### 4.5.2 EXIT BY WDT TIME-OUT

A WDT time-out will cause different actions depending on which power-managed mode the device is in when the time-out occurs.

If the device is not executing code (all Idle modes and Sleep mode), the time-out will result in an exit from the power-managed mode (see [Section 4.2 “Run Modes”](#) and [Section 4.3 “Sleep Mode”](#)). If the device is executing code (all Run modes), the time-out will result in a WDT Reset (see [Section 26.2 “Watchdog Timer \(WDT\)”](#)).

The Watchdog Timer and postscaler are cleared by one of the following events:

- executing a SLEEP or CLRWDT instruction
- the loss of a currently selected clock source (if the Fail-Safe Clock Monitor is enabled)

### 4.5.3 EXIT BY RESET

Exiting an Idle or Sleep mode by Reset automatically forces the device to run from the INTRC.

### 4.5.4 EXIT WITHOUT AN OSCILLATOR START-UP DELAY

Certain exits from power-managed modes do not invoke the OST at all. There are two cases:

- PRI\_IDLE mode, where the primary clock source is not stopped; and
- the primary clock source is either the EC or ECPLL mode.

In these instances, the primary clock source either does not require an oscillator start-up delay, since it is already running (PRI\_IDLE), or normally does not require an oscillator start-up delay (EC). However, a fixed delay of interval, T<sub>CSD</sub>, following the wake event is still required when leaving Sleep and Idle modes to allow the CPU to prepare for execution. Instruction execution resumes on the first clock cycle following this delay.

## 5.0 RESET

The PIC18F87J72 family of devices differentiates between various kinds of Reset:

- Power-on Reset (POR)
- $\overline{\text{MCLR}}$  Reset during normal operation
- $\overline{\text{MCLR}}$  Reset during power-managed modes
- Watchdog Timer (WDT) Reset (during execution)
- Brown-out Reset (BOR)
- Configuration Mismatch (CM)
- RESET Instruction
- Stack Full Reset
- Stack Underflow Reset

This section discusses Resets generated by  $\overline{\text{MCLR}}$ , POR and BOR, and covers the operation of the various start-up timers. Stack Reset events are covered in [Section 6.1.0.1 “Stack Full and Underflow Resets”](#). WDT Resets are covered in [Section 26.2 “Watchdog Timer \(WDT\)”](#).

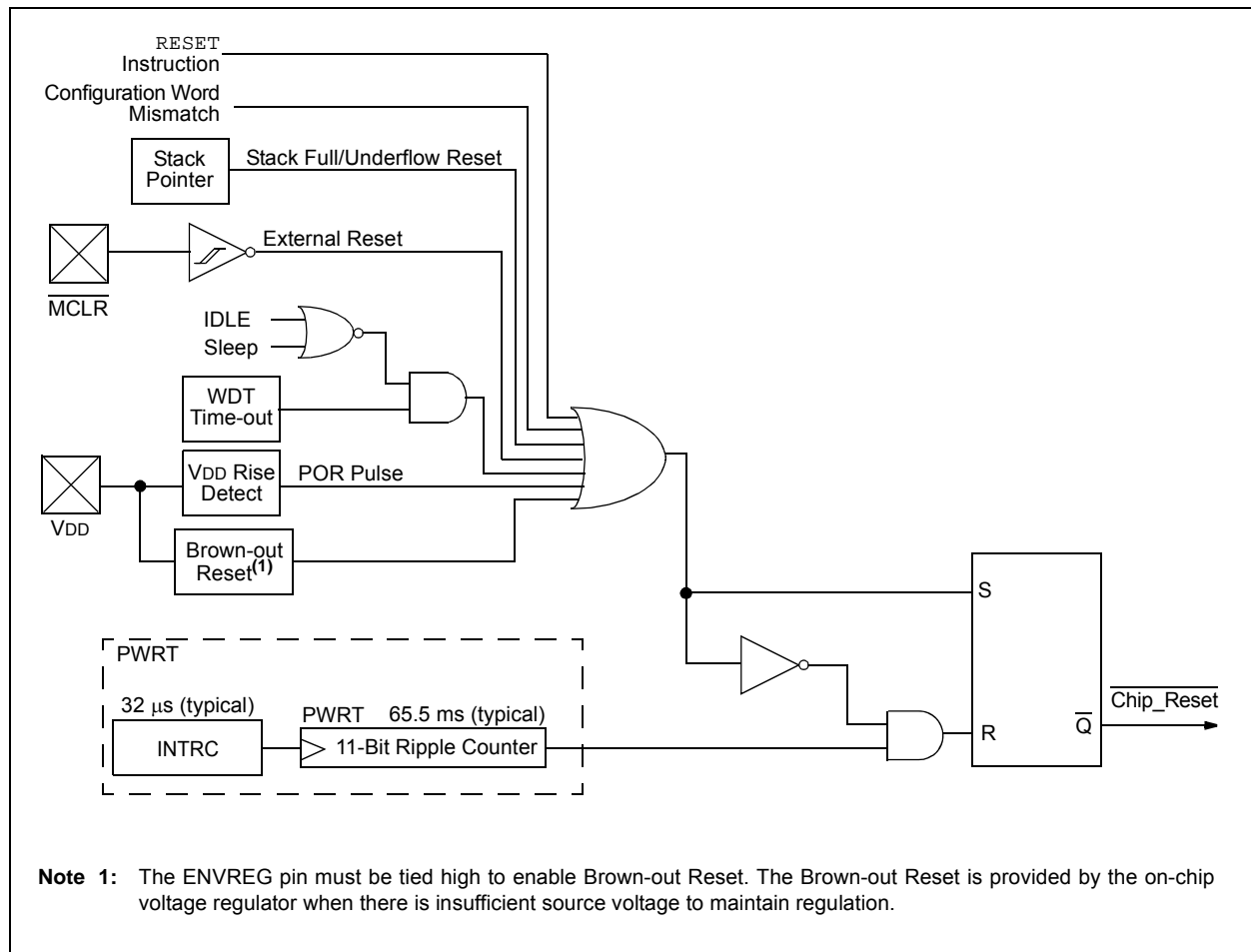
A simplified block diagram of the on-chip Reset circuit is shown in [Figure 5-1](#).

## 5.1 RCON Register

Device Reset events are tracked through the RCON register ([Register 5-1](#)). The lower five bits of the register indicate that a specific Reset event has occurred. In most cases, these bits can only be set by the event and must be cleared by the application after the event. The state of these flag bits, taken together, can be read to indicate the type of Reset that just occurred. This is described in more detail in [Section 5.7 “Reset State of Registers”](#).

The RCON register also has a control bit for setting interrupt priority (IPEN). Interrupt priority is discussed in [Section 9.0 “Interrupts”](#).

**FIGURE 5-1: SIMPLIFIED BLOCK DIAGRAM OF ON-CHIP RESET CIRCUIT**



# PIC18F87J72

## REGISTER 5-1: RCON: RESET CONTROL REGISTER

R/W-0	U-0	R/W-1	R/W-1	R-1	R-1	R/W-0	R/W-0
IPEN	—	$\overline{\text{CM}}$	$\overline{\text{RI}}$	$\overline{\text{TO}}$	$\overline{\text{PD}}$	$\overline{\text{POR}}$	$\overline{\text{BOR}}$
bit 7							bit 0

### Legend:

R = Readable bit                      W = Writable bit                      U = Unimplemented bit, read as '0'  
 -n = Value at POR                      '1' = Bit is set                      '0' = Bit is cleared                      x = Bit is unknown

- bit 7            **IPEN:** Interrupt Priority Enable bit  
 1 = Enable priority levels on interrupts  
 0 = Disable priority levels on interrupts (PIC16XXXX Compatibility mode)
- bit 6            **Unimplemented:** Read as '0'
- bit 5             **$\overline{\text{CM}}$ :** Configuration Mismatch (CM) Flag bit  
 1 = A Configuration Mismatch has not occurred  
 0 = A Configuration Mismatch has occurred (Must be set in software after a Configuration Mismatch Reset occurs.)
- bit 4             **$\overline{\text{RI}}$ :** RESET Instruction Flag bit  
 1 = The RESET instruction was not executed (set by firmware only)  
 0 = The RESET instruction was executed causing a device Reset (must be set in software after a Brown-out Reset occurs)
- bit 3             **$\overline{\text{TO}}$ :** Watchdog Time-out Flag bit  
 1 = Set by power-up, CLRWDT instruction or SLEEP instruction  
 0 = A WDT time-out occurred
- bit 2             **$\overline{\text{PD}}$ :** Power-Down Detection Flag bit  
 1 = Set by power-up or by the CLRWDT instruction  
 0 = Set by execution of the SLEEP instruction
- bit 1             **$\overline{\text{POR}}$ :** Power-on Reset Status bit  
 1 = A Power-on Reset has not occurred (set by firmware only)  
 0 = A Power-on Reset occurred (must be set in software after a Power-on Reset occurs)
- bit 0             **$\overline{\text{BOR}}$ :** Brown-out Reset Status bit  
 1 = A Brown-out Reset has not occurred (set by firmware only)  
 0 = A Brown-out Reset occurred (must be set in software after a Brown-out Reset occurs)

- Note 1:** It is recommended that the  $\overline{\text{POR}}$  bit be set after a Power-on Reset has been detected, so that subsequent Power-on Resets may be detected.
- 2:** If the on-chip voltage regulator is disabled,  $\overline{\text{BOR}}$  remains '0' at all times. See [Section 5.4.1 “Detecting BOR”](#) for more information.
- 3:** Brown-out Reset is said to have occurred when  $\overline{\text{BOR}}$  is '0' and  $\overline{\text{POR}}$  is '1' (assuming that  $\overline{\text{POR}}$  was set to '1' by software immediately after a Power-on Reset).



## 5.2 Master Clear ( $\overline{\text{MCLR}}$ )

The  $\overline{\text{MCLR}}$  pin provides a method for triggering a hard external Reset of the device. A Reset is generated by holding the pin low. PIC18 extended microcontroller devices have a noise filter in the  $\overline{\text{MCLR}}$  Reset path which detects and ignores small pulses.

The  $\overline{\text{MCLR}}$  pin is not driven low by any internal Resets, including the WDT.

## 5.3 Power-on Reset (POR)

A Power-on Reset condition is generated on-chip whenever  $V_{DD}$  rises above a certain threshold. This allows the device to start in the initialized state when  $V_{DD}$  is adequate for operation.

To take advantage of the POR circuitry, tie the  $\overline{\text{MCLR}}$  pin through a resistor (1 k $\Omega$  to 10 k $\Omega$ ) to  $V_{DD}$ . This will eliminate external RC components usually needed to create a Power-on Reset delay. A minimum rise rate for  $V_{DD}$  is specified (parameter D004). For a slow rise time, see Figure 5-2.

When the device starts normal operation (i.e., exits the Reset condition), device operating parameters (voltage, frequency, temperature, etc.) must be met to ensure operation. If these conditions are not met, the device must be held in Reset until the operating conditions are met.

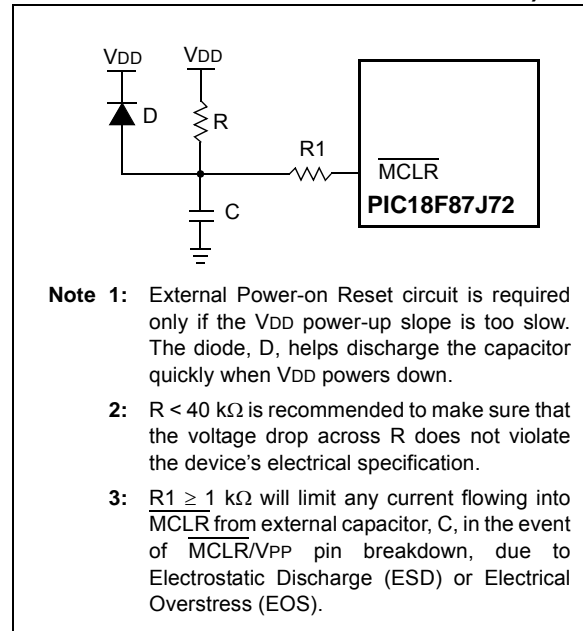
Power-on Reset events are captured by the  $\overline{\text{POR}}$  bit (RCON<1>). The state of the bit is set to '0' whenever a Power-on Reset occurs; it does not change for any other Reset event.  $\overline{\text{POR}}$  is not reset to '1' by any hardware event. To capture multiple events, the user manually resets the bit to '1' in software following any Power-on Reset.

## 5.4 Brown-out Reset (BOR)

The PIC18F87J72 family of devices incorporates a simple BOR function when the internal regulator is enabled (ENVREG pin is tied to  $V_{DD}$ ). The voltage regulator will trigger a Brown-out Reset when output of the regulator to the device core approaches the voltage at which the device is unable to run at full speed. The BOR circuit also keeps the device in Reset as  $V_{DD}$  rises, until the regulator's output level is sufficient for full-speed operation.

Once a BOR has occurred, the Power-up Timer will keep the chip in Reset for  $T_{PWRT}$  (parameter 33). If  $V_{DD}$  drops below the threshold for full-speed operation while the Power-up Timer is running, the chip will go back into a Brown-out Reset and the Power-up Timer will be initialized. Once  $V_{DD}$  rises to the point where regulator output is sufficient, the Power-up Timer will execute the additional time delay.

**FIGURE 5-2: EXTERNAL POWER-ON RESET CIRCUIT (FOR SLOW  $V_{DD}$  POWER-UP)**



### 5.4.1 DETECTING BOR

The  $\overline{\text{BOR}}$  bit always resets to '0' on any Brown-out Reset or Power-on Reset event. This makes it difficult to determine if a Brown-out Reset event has occurred just by reading the state of  $\overline{\text{BOR}}$  alone. A more reliable method is to simultaneously check the state of both  $\overline{\text{POR}}$  and  $\overline{\text{BOR}}$ . This assumes that the  $\overline{\text{POR}}$  bit is reset to '1' in software immediately after any Power-on Reset event. If  $\overline{\text{BOR}}$  is '0' while  $\overline{\text{POR}}$  is '1', it can be reliably assumed that a Brown-out Reset event has occurred.

If the voltage regulator is disabled, Brown-out Reset functionality is disabled. In this case, the  $\overline{\text{BOR}}$  bit cannot be used to determine a Brown-out Reset event. The  $\overline{\text{BOR}}$  bit is still cleared by a Power-on Reset event.

## 5.5 Configuration Mismatch (CM)

The Configuration Mismatch (CM) Reset is designed to detect, and attempt to recover from, random memory corrupting events. These include Electrostatic Discharge (ESD) events that can cause widespread, single bit changes throughout the device and result in catastrophic failure.

In PIC18F87J72 family Flash devices, the device Configuration registers (located in the configuration memory space) are continuously monitored during operation by comparing their values to complimentary shadow registers. If a mismatch is detected between the two sets of registers, a  $\overline{\text{CM}}$  Reset automatically occurs. These events are captured by the CM bit (RCON<5>). The state of the bit is set to '0' whenever a CM event occurs. The bit does not change for any other Reset event.

# PIC18F87J72

## 5.6 Power-up Timer (PWRT)

PIC18F87J72 family devices incorporate an on-chip Power-up Timer (PWRT) to help regulate the Power-on Reset process. The PWRT is always enabled. The main function is to ensure that the device voltage is stable before code is executed.

The Power-up Timer (PWRT) of the PIC18F87J72 family devices is an 11-bit counter which uses the INTRC source as the clock input. This yields an approximate time interval of  $2048 \times 32 \mu\text{s} = 65.6 \text{ ms}$ . While the PWRT is counting, the device is held in Reset.

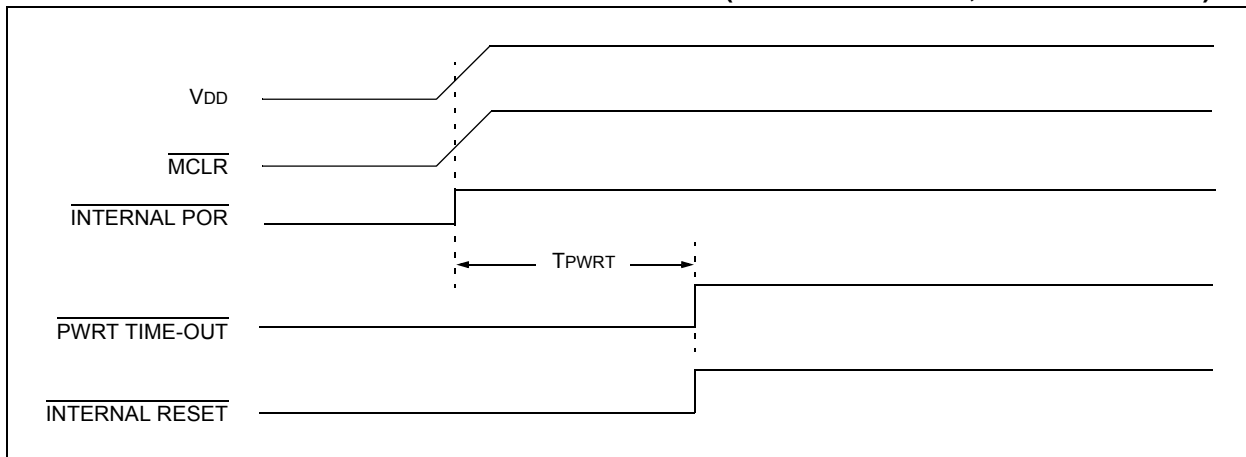
The power-up time delay depends on the INTRC clock and will vary from chip to chip due to temperature and process variation. See DC Parameter 33 for details.

### 5.6.1 TIME-OUT SEQUENCE

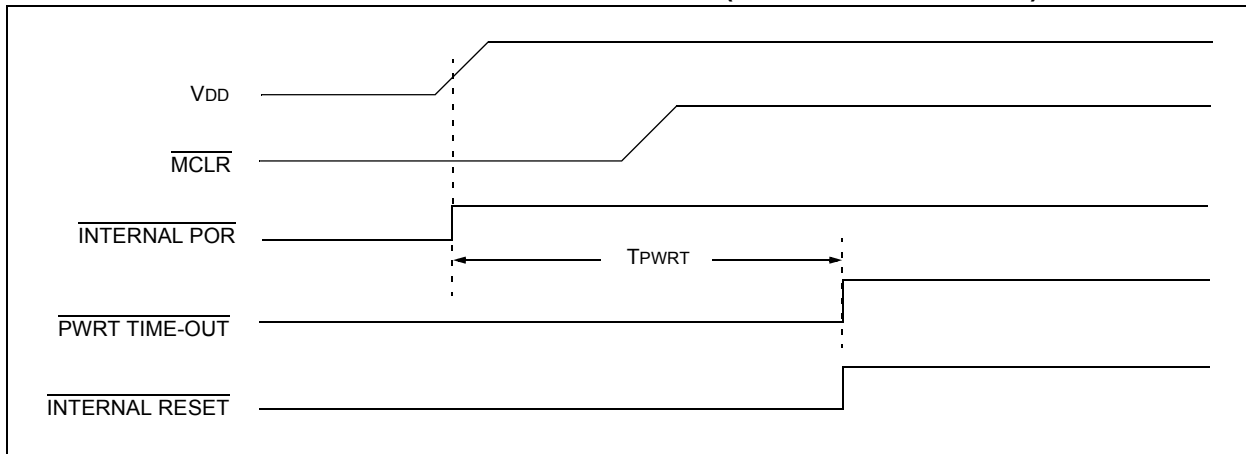
If enabled, the PWRT time-out is invoked after the POR pulse has cleared. The total time-out will vary based on the status of the PWRT. [Figure 5-3](#), [Figure 5-4](#), [Figure 5-5](#) and [Figure 5-6](#) all depict time-out sequences on power-up with the Power-up Timer enabled.

Since the time-outs occur from the POR pulse, if  $\overline{\text{MCLR}}$  is kept low long enough, the PWRT will expire. Bringing  $\overline{\text{MCLR}}$  high will begin execution immediately ([Figure 5-5](#)). This is useful for testing purposes, or to synchronize more than one PIC18FXXXX device operating in parallel.

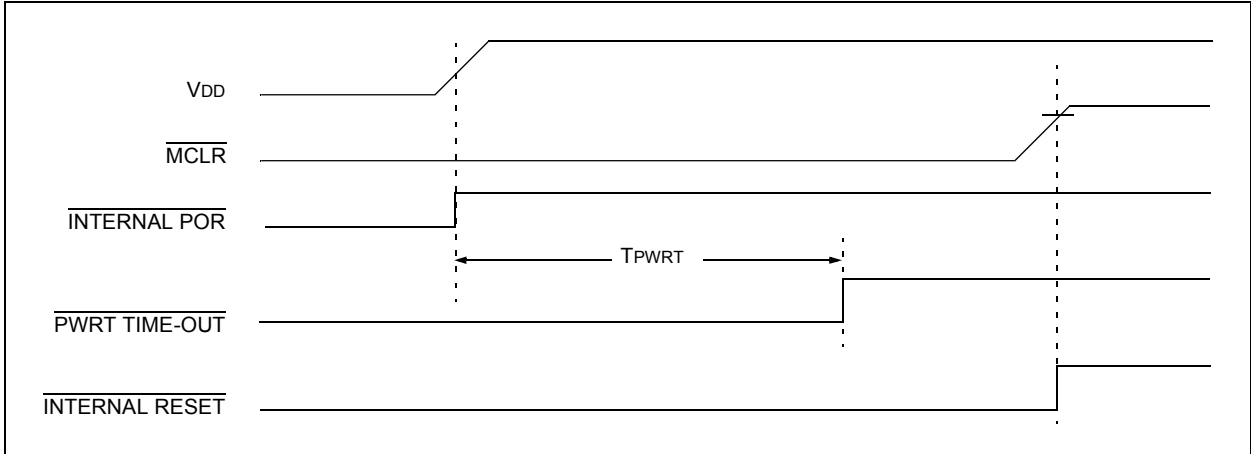
**FIGURE 5-3: TIME-OUT SEQUENCE ON POWER-UP ( $\overline{\text{MCLR}}$  TIED TO  $V_{DD}$ ,  $V_{DD}$  RISE  $<$   $T_{PWRT}$ )**



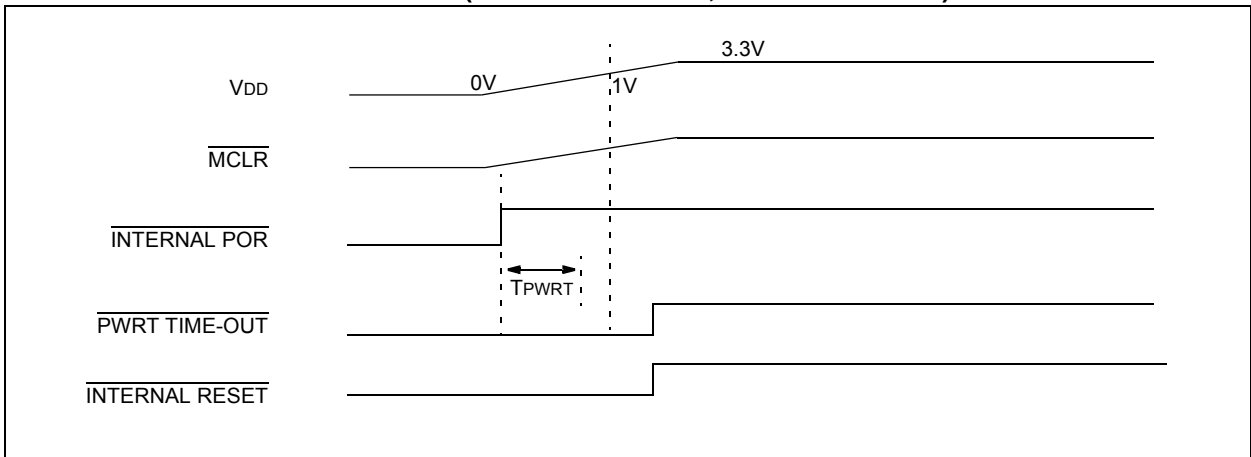
**FIGURE 5-4: TIME-OUT SEQUENCE ON POWER-UP ( $\overline{\text{MCLR}}$  NOT TIED TO  $V_{DD}$ ): CASE 1**



**FIGURE 5-5: TIME-OUT SEQUENCE ON POWER-UP ( $\overline{\text{MCLR}}$  NOT TIED TO  $V_{DD}$ ): CASE 2**



**FIGURE 5-6: SLOW RISE TIME ( $\overline{\text{MCLR}}$  TIED TO  $V_{DD}$ ,  $V_{DD}$  RISE >  $T_{PWRT}$ )**



# PIC18F87J72

## 5.7 Reset State of Registers

Most registers are unaffected by a Reset. Their status is unknown on POR and unchanged by all other Resets. The other registers are forced to a “Reset state” depending on the type of Reset that occurred.

Most registers are not affected by a WDT wake-up, since this is viewed as the resumption of normal operation. Status bits from the RCON register,  $\overline{RI}$ ,  $\overline{TO}$ ,  $\overline{PD}$ ,  $\overline{POR}$  and  $\overline{BOR}$ , are set or cleared differently in different Reset situations, as indicated in Table 5-1. These bits are used in software to determine the nature of the Reset.

Table 5-2 describes the Reset states for all of the Special Function Registers. These are categorized by Power-on and Brown-out Resets, Master Clear and WDT Resets and WDT wake-ups.

**TABLE 5-1: STATUS BITS, THEIR SIGNIFICANCE AND THE INITIALIZATION CONDITION FOR RCON REGISTER**

Condition	Program Counter <sup>(1)</sup>	RCON Register					STKPTR Register	
		$\overline{RI}$	$\overline{TO}$	$\overline{PD}$	$\overline{POR}$	$\overline{BOR}$	STKFUL	STKUNF
Power-on Reset	0000h	1	1	1	0	0	0	0
RESET Instruction	0000h	0	u	u	u	u	u	u
Brown-out Reset	0000h	1	1	1	u	0	u	u
$\overline{MCLR}$ during power-managed Run modes	0000h	u	1	u	u	u	u	u
$\overline{MCLR}$ during power-managed Idle modes and Sleep mode	0000h	u	1	0	u	u	u	u
WDT time-out during full power or power-managed Run modes	0000h	u	0	u	u	u	u	u
$\overline{MCLR}$ during full power execution	0000h	u	u	u	u	u	u	u
Stack Full Reset (STVREN = 1)	0000h	u	u	u	u	u	1	u
Stack Underflow Reset (STVREN = 1)	0000h	u	u	u	u	u	u	1
Stack Underflow Error (not an actual Reset, STVREN = 0)	0000h	u	u	u	u	u	u	1
WDT time-out during power-managed Idle or Sleep modes	PC + 2	u	0	0	u	u	u	u
Interrupt exit from power-managed modes	PC + 2	u	u	0	u	u	u	u

Legend: u = unchanged

**Note 1:** When the wake-up is due to an interrupt and the GIEH or GIEL bit is set, the PC is loaded with the interrupt vector (0008h or 0018h).

**TABLE 5-2: INITIALIZATION CONDITIONS FOR ALL REGISTERS**

Register	Applicable Devices	Power-on Reset, Brown-out Reset	MCLR Resets WDT Reset RESET Instruction Stack Resets	Wake-up via WDT or Interrupt
TOSU	PIC18F8XJ72	---0 0000	---0 0000	---0 uuuu <sup>(1)</sup>
TOSH	PIC18F8XJ72	0000 0000	0000 0000	uuuu uuuu <sup>(1)</sup>
TOSL	PIC18F8XJ72	0000 0000	0000 0000	uuuu uuuu <sup>(1)</sup>
STKPTR	PIC18F8XJ72	uu-0 0000	00-0 0000	uu-u uuuu <sup>(1)</sup>
PCLATU	PIC18F8XJ72	---0 0000	---0 0000	---u uuuu
PCLATH	PIC18F8XJ72	0000 0000	0000 0000	uuuu uuuu
PCL	PIC18F8XJ72	0000 0000	0000 0000	PC + 2 <sup>(2)</sup>
TBLPTRU	PIC18F8XJ72	--00 0000	--00 0000	--uu uuuu
TBLPTRH	PIC18F8XJ72	0000 0000	0000 0000	uuuu uuuu
TBLPTRL	PIC18F8XJ72	0000 0000	0000 0000	uuuu uuuu
TABLAT	PIC18F8XJ72	0000 0000	0000 0000	uuuu uuuu
PRODH	PIC18F8XJ72	xxxx xxxx	uuuu uuuu	uuuu uuuu
PRODL	PIC18F8XJ72	xxxx xxxx	uuuu uuuu	uuuu uuuu
INTCON	PIC18F8XJ72	0000 000x	0000 000u	uuuu uuuu <sup>(3)</sup>
INTCON2	PIC18F8XJ72	1111 1111	1111 1111	uuuu uuuu <sup>(3)</sup>
INTCON3	PIC18F8XJ72	1100 0000	1100 0000	uuuu uuuu <sup>(3)</sup>
INDF0	PIC18F8XJ72	N/A	N/A	N/A
POSTINC0	PIC18F8XJ72	N/A	N/A	N/A
POSTDEC0	PIC18F8XJ72	N/A	N/A	N/A
PREINC0	PIC18F8XJ72	N/A	N/A	N/A
PLUSW0	PIC18F8XJ72	N/A	N/A	N/A
FSR0H	PIC18F8XJ72	---- xxxx	---- uuuu	---- uuuu
FSR0L	PIC18F8XJ72	xxxx xxxx	uuuu uuuu	uuuu uuuu
WREG	PIC18F8XJ72	xxxx xxxx	uuuu uuuu	uuuu uuuu
INDF1	PIC18F8XJ72	N/A	N/A	N/A
POSTINC1	PIC18F8XJ72	N/A	N/A	N/A
POSTDEC1	PIC18F8XJ72	N/A	N/A	N/A
PREINC1	PIC18F8XJ72	N/A	N/A	N/A
PLUSW1	PIC18F8XJ72	N/A	N/A	N/A

Legend: u = unchanged, x = unknown, - = unimplemented bit, read as '0', α = value depends on condition.  
Shaded cells indicate conditions do not apply for the designated device.

- Note 1:** When the wake-up is due to an interrupt and the GIEL or GIEH bit is set, the TOSU, TOSH and TOSL are updated with the current value of the PC. The STKPTR is modified to point to the next location in the hardware stack.
- 2:** When the wake-up is due to an interrupt and the GIEL or GIEH bit is set, the PC is loaded with the interrupt vector (0008h or 0018h).
- 3:** One or more bits in the INTCONx or PIRx registers will be affected (to cause wake-up).
- 4:** See [Table 5-1](#) for Reset value for specific condition.
- 5:** Bits 6 and 7 of PORTA, LATA and TRISA are enabled depending on the oscillator mode selected. When not enabled as PORTA pins, they are disabled and read as '0'.

# PIC18F87J72

**TABLE 5-2: INITIALIZATION CONDITIONS FOR ALL REGISTERS (CONTINUED)**

Register	Applicable Devices	Power-on Reset, Brown-out Reset	MCLR Resets WDT Reset RESET Instruction Stack Resets	Wake-up via WDT or Interrupt
FSR1H	PIC18F8XJ72	---- xxxx	---- uuuu	---- uuuu
FSR1L	PIC18F8XJ72	xxxx xxxx	uuuu uuuu	uuuu uuuu
BSR	PIC18F8XJ72	---- 0000	---- 0000	---- uuuu
INDF2	PIC18F8XJ72	N/A	N/A	N/A
POSTINC2	PIC18F8XJ72	N/A	N/A	N/A
POSTDEC2	PIC18F8XJ72	N/A	N/A	N/A
PREINC2	PIC18F8XJ72	N/A	N/A	N/A
PLUSW2	PIC18F8XJ72	N/A	N/A	N/A
FSR2H	PIC18F8XJ72	---- xxxx	---- uuuu	---- uuuu
FSR2L	PIC18F8XJ72	xxxx xxxx	uuuu uuuu	uuuu uuuu
STATUS	PIC18F8XJ72	---x xxxx	---u uuuu	---u uuuu
TMR0H	PIC18F8XJ72	0000 0000	0000 0000	uuuu uuuu
TMR0L	PIC18F8XJ72	xxxx xxxx	uuuu uuuu	uuuu uuuu
T0CON	PIC18F8XJ72	1111 1111	1111 1111	uuuu uuuu
OSCCON	PIC18F8XJ72	0110 q000	0110 q000	uuuu quuu
LCDREG	PIC18F8XJ72	-011 1100	-011 1000	-uuu uuuu
WDTCON	PIC18F8XJ72	0--- ---0	0--- ---0	u--- ---u
RCON <sup>(4)</sup>	PIC18F8XJ72	0-11 11q0	0-0q qquu	u-uu qquu
TMR1H	PIC18F8XJ72	xxxx xxxx	uuuu uuuu	uuuu uuuu
TMR1L	PIC18F8XJ72	xxxx xxxx	uuuu uuuu	uuuu uuuu
T1CON	PIC18F8XJ72	0000 0000	u0uu uuuu	uuuu uuuu
TMR2	PIC18F8XJ72	0000 0000	0000 0000	uuuu uuuu
PR2	PIC18F8XJ72	1111 1111	1111 1111	1111 1111
T2CON	PIC18F8XJ72	-000 0000	-000 0000	-uuu uuuu
SSPBUF	PIC18F8XJ72	xxxx xxxx	uuuu uuuu	uuuu uuuu
SSPADD	PIC18F8XJ72	0000 0000	0000 0000	uuuu uuuu
SSPSTAT	PIC18F8XJ72	0000 0000	0000 0000	uuuu uuuu
SSPCON1	PIC18F8XJ72	0000 0000	0000 0000	uuuu uuuu
SSPCON2	PIC18F8XJ72	0000 0000	0000 0000	uuuu uuuu

Legend: u = unchanged, x = unknown, - = unimplemented bit, read as '0', q = value depends on condition. Shaded cells indicate conditions do not apply for the designated device.

- Note 1:** When the wake-up is due to an interrupt and the GIEL or GIEH bit is set, the TOSU, TOSH and TOSL are updated with the current value of the PC. The STKPTR is modified to point to the next location in the hardware stack.
- 2:** When the wake-up is due to an interrupt and the GIEL or GIEH bit is set, the PC is loaded with the interrupt vector (0008h or 0018h).
- 3:** One or more bits in the INTCONx or PIRx registers will be affected (to cause wake-up).
- 4:** See [Table 5-1](#) for Reset value for specific condition.
- 5:** Bits 6 and 7 of PORTA, LATA and TRISA are enabled depending on the oscillator mode selected. When not enabled as PORTA pins, they are disabled and read as '0'.

**TABLE 5-2: INITIALIZATION CONDITIONS FOR ALL REGISTERS (CONTINUED)**

Register	Applicable Devices	Power-on Reset, Brown-out Reset	MCLR Resets WDT Reset RESET Instruction Stack Resets	Wake-up via WDT or Interrupt
ADRESH	PIC18F8XJ72	xxxx xxxx	uuuu uuuu	uuuu uuuu
ADRESL	PIC18F8XJ72	xxxx xxxx	uuuu uuuu	uuuu uuuu
ADCON0	PIC18F8XJ72	0-00 0000	0-00 0000	u-uu uuuu
ADCON1	PIC18F8XJ72	0-00 0000	0-00 0000	u-uu uuuu
ADCON2	PIC18F8XJ72	0-00 0000	0-00 0000	u-uu uuuu
LCDDATA4	PIC18F8XJ72	---- -x	---- -u	---- -u
LCDDATA3	PIC18F8XJ72	xxxx xxxx	uuuu uuuu	uuuu uuuu
LCDDATA2	PIC18F8XJ72	xxxx xxxx	uuuu uuuu	uuuu uuuu
LCDDATA1	PIC18F8XJ72	xxxx xxxx	uuuu uuuu	uuuu uuuu
LCDDATA0	PIC18F8XJ72	xxxx xxxx	uuuu uuuu	uuuu uuuu
LCDSE4	PIC18F8XJ72	---- -0	---- -u	---- -u
LCDSE3	PIC18F8XJ72	0000 0000	uuuu uuuu	uuuu uuuu
LCDSE2	PIC18F8XJ72	0000 0000	uuuu uuuu	uuuu uuuu
LCDSE1	PIC18F8XJ72	0000 0000	uuuu uuuu	uuuu uuuu
CVRCON	PIC18F8XJ72	0000 0000	0000 0000	uuuu uuuu
CMCON	PIC18F8XJ72	0000 0111	0000 0111	uuuu uuuu
TMR3H	PIC18F8XJ72	xxxx xxxx	uuuu uuuu	uuuu uuuu
TMR3L	PIC18F8XJ72	xxxx xxxx	uuuu uuuu	uuuu uuuu
T3CON	PIC18F8XJ72	0000 0000	uuuu uuuu	uuuu uuuu
SPBRG1	PIC18F8XJ72	0000 0000	0000 0000	uuuu uuuu
RCREG1	PIC18F8XJ72	0000 0000	0000 0000	uuuu uuuu
TXREG1	PIC18F8XJ72	0000 0000	0000 0000	uuuu uuuu
TXSTA1	PIC18F8XJ72	0000 0010	0000 0010	uuuu uuuu
RCSTA1	PIC18F8XJ72	0000 000x	0000 000x	uuuu uuuu
LCDPS	PIC18F8XJ72	0000 0000	0000 0000	uuuu uuuu
LCDSE0	PIC18F8XJ72	0000 0000	uuuu uuuu	uuuu uuuu
LCDCON	PIC18F8XJ72	000- 0000	000- 0000	uuu- uuuu
EECON2	PIC18F8XJ72	---- ----	---- ----	---- ----
EECON1	PIC18F8XJ72	---0 x00-	---0 u00-	---0 u00-

Legend: u = unchanged, x = unknown, - = unimplemented bit, read as '0', q = value depends on condition. Shaded cells indicate conditions do not apply for the designated device.

- Note 1:** When the wake-up is due to an interrupt and the GIEL or GIEH bit is set, the TOSU, TOSH and TOSL are updated with the current value of the PC. The STKPTR is modified to point to the next location in the hardware stack.
- 2:** When the wake-up is due to an interrupt and the GIEL or GIEH bit is set, the PC is loaded with the interrupt vector (0008h or 0018h).
- 3:** One or more bits in the INTCONx or PIRx registers will be affected (to cause wake-up).
- 4:** See [Table 5-1](#) for Reset value for specific condition.
- 5:** Bits 6 and 7 of PORTA, LATA and TRISA are enabled depending on the oscillator mode selected. When not enabled as PORTA pins, they are disabled and read as '0'.

# PIC18F87J72

**TABLE 5-2: INITIALIZATION CONDITIONS FOR ALL REGISTERS (CONTINUED)**

Register	Applicable Devices	Power-on Reset, Brown-out Reset	MCLR Resets WDT Reset RESET Instruction Stack Resets	Wake-up via WDT or Interrupt
IPR3	PIC18F8XJ72	-111 1111	-111 1111	-uuu 1111
PIR3	PIC18F8XJ72	-000 0000	-000 0000	-uuu 0000 <sup>(3)</sup>
PIE3	PIC18F8XJ72	-000 0000	-000 0000	-uuu 0000
IPR2	PIC18F8XJ72	11-- 111-	11-- 111-	uu-- uu-
PIR2	PIC18F8XJ72	00-- 000-	00-- 000-	uu-- uu- <sup>(3)</sup>
PIE2	PIC18F8XJ72	00-- 000-	00-- 000-	uu-- uu-
IPR1	PIC18F8XJ72	-111 1-11	-111 1-11	-uuu u-uu
PIR1	PIC18F8XJ72	-000 0-00	-000 0-00	-uuu u-uu <sup>(3)</sup>
PIE1	PIC18F8XJ72	-000 0-00	-000 0-00	-uuu u-uu
OSCTUNE	PIC18F8XJ72	0000 0000	0000 0000	uuuu uuuu
TRISG	PIC18F8XJ72	0001 1111	0001 1111	uuuu uuuu
TRISF	PIC18F8XJ72	1111 111-	1111 111-	uuuu uu-
TRISE	PIC18F8XJ72	1111 1-11	1111 1-11	uuuu u-uu
TRISD	PIC18F8XJ72	1111 1111	1111 1111	uuuu uuuu
TRISC	PIC18F8XJ72	1111 1111	1111 1111	uuuu uuuu
TRISB	PIC18F8XJ72	1111 1111	1111 1111	uuuu uuuu
TRISA <sup>(5)</sup>	PIC18F8XJ72	1111 1111 <sup>(5)</sup>	1111 1111 <sup>(5)</sup>	uuuu uuuu <sup>(5)</sup>
LATG	PIC18F8XJ72	00-x xxxx	00-u uuuu	uu-u uuuu
LATF	PIC18F8XJ72	xxxx xxx-	uuuu uu-	uuuu uu-
LATE	PIC18F8XJ72	xxxx x-xx	uuuu u-uu	uuuu u-uu
LATD	PIC18F8XJ72	xxxx xxxx	uuuu uuuu	uuuu uuuu
LATC	PIC18F8XJ72	xxxx xxxx	uuuu uuuu	uuuu uuuu
LATB	PIC18F8XJ72	xxxx xxxx	uuuu uuuu	uuuu uuuu
LATA <sup>(5)</sup>	PIC18F8XJ72	xxxx xxxx <sup>(5)</sup>	uuuu uuuu <sup>(5)</sup>	uuuu uuuu <sup>(5)</sup>
PORTG	PIC18F8XJ72	000x xxxx	000u uuuu	000u uuuu
PORTF	PIC18F8XJ72	xxxx xxx-	uuuu uu-	uuuu uu-
PORTE	PIC18F8XJ72	xxxx x-xx	uuuu u-uu	uuuu u-uu
PORTD	PIC18F8XJ72	xxxx xxxx	uuuu uuuu	uuuu uuuu
PORTC	PIC18F8XJ72	xxxx xxxx	uuuu uuuu	uuuu uuuu
PORTB	PIC18F8XJ72	xxxx xxxx	uuuu uuuu	uuuu uuuu
PORTA <sup>(5)</sup>	PIC18F8XJ72	xx0x 0000 <sup>(5)</sup>	uu0u 0000 <sup>(5)</sup>	uuuu uuuu <sup>(5)</sup>

Legend: u = unchanged, x = unknown, - = unimplemented bit, read as '0', q = value depends on condition. Shaded cells indicate conditions do not apply for the designated device.

**Note 1:** When the wake-up is due to an interrupt and the GIEL or GIEH bit is set, the TOSU, TOSH and TOSL are updated with the current value of the PC. The STKPTR is modified to point to the next location in the hardware stack.

**2:** When the wake-up is due to an interrupt and the GIEL or GIEH bit is set, the PC is loaded with the interrupt vector (0008h or 0018h).

**3:** One or more bits in the INTCONx or PIRx registers will be affected (to cause wake-up).

**4:** See [Table 5-1](#) for Reset value for specific condition.

**5:** Bits 6 and 7 of PORTA, LATA and TRISA are enabled depending on the oscillator mode selected. When not enabled as PORTA pins, they are disabled and read as '0'.



**TABLE 5-2: INITIALIZATION CONDITIONS FOR ALL REGISTERS (CONTINUED)**

Register	Applicable Devices	Power-on Reset, Brown-out Reset	MCLR Resets WDT Reset RESET Instruction Stack Resets	Wake-up via WDT or Interrupt
SPBRGH1	PIC18F8XJ72	0000 0000	0000 0000	uuuu uuuu
BAUDCON1	PIC18F8XJ72	0100 0-00	0100 0-00	uuuu u-uu
LCDDATA22	PIC18F8XJ72	---- -x	---- -u	---- -u
LCDDATA22	PIC18F8XJ72	xxxx xxxx	uuuu uuuu	uuuu uuuu
LCDDATA21	PIC18F8XJ72	xxxx xxxx	uuuu uuuu	uuuu uuuu
LCDDATA20	PIC18F8XJ72	xxxx xxxx	uuuu uuuu	uuuu uuuu
LCDDATA19	PIC18F8XJ72	xxxx xxxx	uuuu uuuu	uuuu uuuu
LCDDATA18	PIC18F8XJ72	xxxx xxxx	uuuu uuuu	uuuu uuuu
LCDDATA16	PIC18F8XJ72	---- -x	---- -u	---- -u
LCDDATA16	PIC18F8XJ72	xxxx xxxx	uuuu uuuu	uuuu uuuu
LCDDATA15	PIC18F8XJ72	xxxx xxxx	uuuu uuuu	uuuu uuuu
LCDDATA14	PIC18F8XJ72	xxxx xxxx	uuuu uuuu	uuuu uuuu
LCDDATA13	PIC18F8XJ72	xxxx xxxx	uuuu uuuu	uuuu uuuu
LCDDATA12	PIC18F8XJ72	xxxx xxxx	uuuu uuuu	uuuu uuuu
LCDDATA10	PIC18F8XJ72	---- -x	---- -u	---- -u
LCDDATA10	PIC18F8XJ72	xxxx xxxx	uuuu uuuu	uuuu uuuu
LCDDATA9	PIC18F8XJ72	xxxx xxxx	uuuu uuuu	uuuu uuuu
LCDDATA8	PIC18F8XJ72	xxxx xxxx	uuuu uuuu	uuuu uuuu
LCDDATA7	PIC18F8XJ72	xxxx xxxx	uuuu uuuu	uuuu uuuu
LCDDATA6	PIC18F8XJ72	xxxx xxxx	uuuu uuuu	uuuu uuuu
CCPR1H	PIC18F8XJ72	xxxx xxxx	uuuu uuuu	uuuu uuuu
CCPR1L	PIC18F8XJ72	xxxx xxxx	uuuu uuuu	uuuu uuuu
CCP1CON	PIC18F8XJ72	--00 0000	--00 0000	--uu uuuu
CCPR2H	PIC18F8XJ72	xxxx xxxx	uuuu uuuu	uuuu uuuu
CCPR2L	PIC18F8XJ72	xxxx xxxx	uuuu uuuu	uuuu uuuu
CCP2CON	PIC18F8XJ72	--00 0000	--00 0000	--uu uuuu

Legend: u = unchanged, x = unknown, - = unimplemented bit, read as '0', q = value depends on condition. Shaded cells indicate conditions do not apply for the designated device.

- Note 1:** When the wake-up is due to an interrupt and the GIEL or GIEH bit is set, the TOSU, TOSH and TOSL are updated with the current value of the PC. The STKPTR is modified to point to the next location in the hardware stack.
- 2:** When the wake-up is due to an interrupt and the GIEL or GIEH bit is set, the PC is loaded with the interrupt vector (0008h or 0018h).
- 3:** One or more bits in the INTCONx or PIRx registers will be affected (to cause wake-up).
- 4:** See [Table 5-1](#) for Reset value for specific condition.
- 5:** Bits 6 and 7 of PORTA, LATA and TRISA are enabled depending on the oscillator mode selected. When not enabled as PORTA pins, they are disabled and read as '0'.

# PIC18F87J72

**TABLE 5-2: INITIALIZATION CONDITIONS FOR ALL REGISTERS (CONTINUED)**

Register	Applicable Devices	Power-on Reset, Brown-out Reset	MCLR Resets WDT Reset RESET Instruction Stack Resets	Wake-up via WDT or Interrupt
SPBRG2	PIC18F8XJ72	0000 0000	0000 0000	uuuu uuuu
RCREG2	PIC18F8XJ72	0000 0000	0000 0000	uuuu uuuu
TXREG2	PIC18F8XJ72	0000 0000	0000 0000	uuuu uuuu
TXSTA2	PIC18F8XJ72	0000 -010	0000 -010	uuuu -uuu
RCSTA2	PIC18F8XJ72	0000 000x	0000 000x	uuuu uuuu
RTCCFG	PIC18F8XJ72	0-00 0000	0-00 0000	u-uu uuuu
RTCCAL	PIC18F8XJ72	0000 0000	0000 0000	uuuu uuuu
RTCVALH	PIC18F8XJ72	xxxx xxxx	uuuu uuuu	uuuu uuuu
RTCVALL	PIC18F8XJ72	xxxx xxxx	uuuu uuuu	uuuu uuuu
ALRMCFG	PIC18F8XJ72	0000 0000	0000 0000	uuuu uuuu
ALMRPT	PIC18F8XJ72	0000 0000	0000 0000	uuuu uuuu
ALRMVALH	PIC18F8XJ72	xxxx xxxx	uuuu uuuu	uuuu uuuu
ALRMVALL	PIC18F8XJ72	xxxx xxxx	uuuu uuuu	uuuu uuuu
CTMUCONH	PIC18F8XJ72	0-00 0000	0-00 0000	u-uu uuuu
CTMUCONL	PIC18F8XJ72	0000 0000	0000 0000	uuuu uuuu
CTMUICONH	PIC18F8XJ72	0000 0000	0000 0000	uuuu uuuu
PADCFG1	PIC18F8XJ72	---- -00-	---- -00-	---- -uu-

Legend: u = unchanged, x = unknown, - = unimplemented bit, read as '0', q = value depends on condition.  
Shaded cells indicate conditions do not apply for the designated device.

- Note 1:** When the wake-up is due to an interrupt and the GIEL or GIEH bit is set, the TOSU, TOSH and TOSL are updated with the current value of the PC. The STKPTR is modified to point to the next location in the hardware stack.
- 2:** When the wake-up is due to an interrupt and the GIEL or GIEH bit is set, the PC is loaded with the interrupt vector (0008h or 0018h).
- 3:** One or more bits in the INTCONx or PIRx registers will be affected (to cause wake-up).
- 4:** See [Table 5-1](#) for Reset value for specific condition.
- 5:** Bits 6 and 7 of PORTA, LATA and TRISA are enabled depending on the oscillator mode selected. When not enabled as PORTA pins, they are disabled and read as '0'.

## 6.0 MEMORY ORGANIZATION

There are two types of memory in PIC18 Flash microcontroller devices:

- Program Memory
- Data RAM

As Harvard architecture devices, the data and program memories use separate busses; this allows for concurrent access of the two memory spaces.

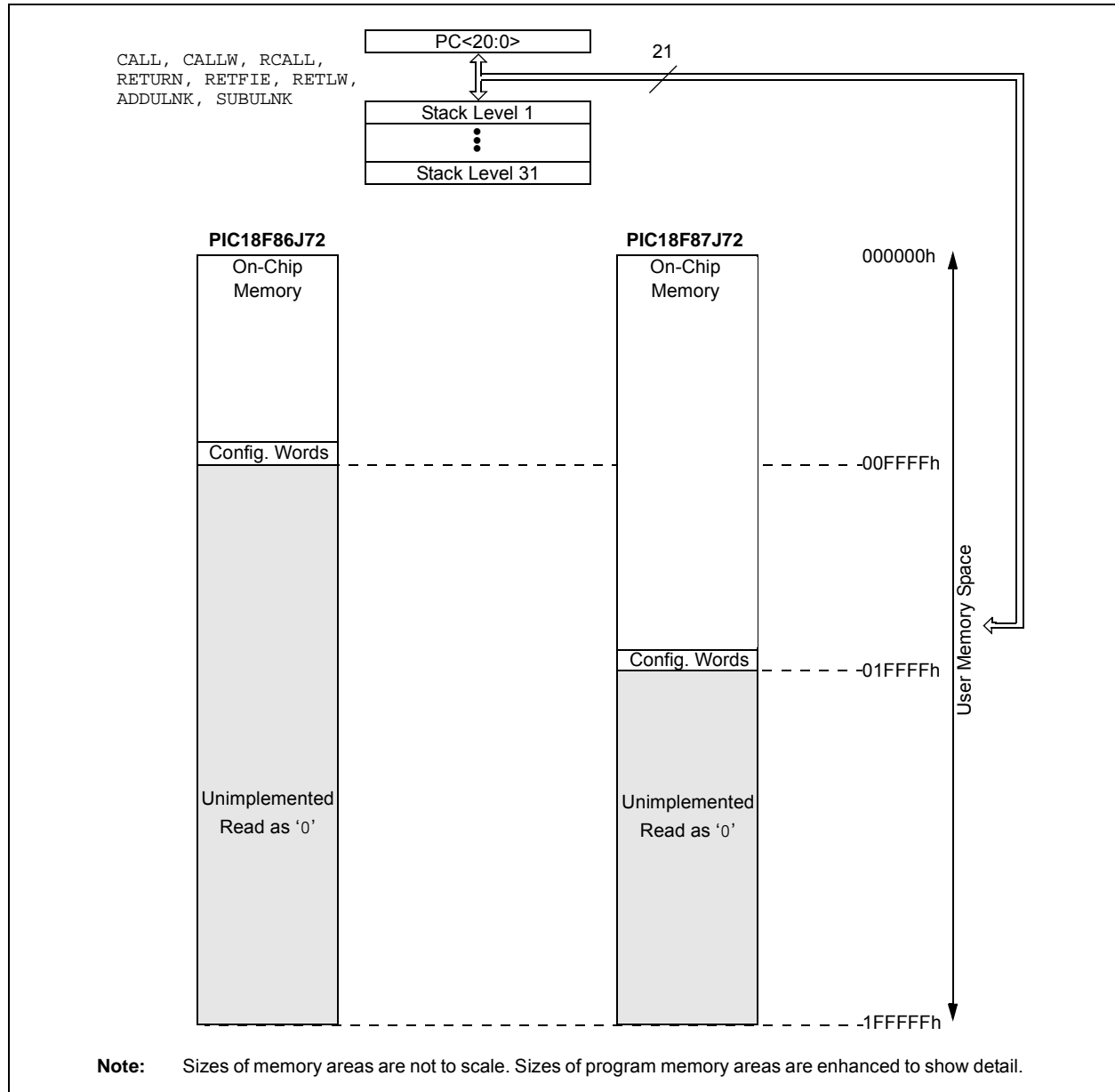
Additional detailed information on the operation of the Flash program memory is provided in [Section 7.0 “Flash Program Memory”](#).

## 6.1 Program Memory Organization

PIC18 microcontrollers implement a 21-bit program counter which is capable of addressing a 2-Mbyte program memory space. Accessing a location between the upper boundary of the physically implemented memory and the 2-Mbyte address will return all ‘0’s (a NOP instruction).

The PIC18F87J72 family has a Flash program memory size of 128 Kbytes (65,536 single-word instructions). The program memory maps for individual family members are shown in [Figure 6-1](#).

**FIGURE 6-1: MEMORY MAPS FOR PIC18F87J72 FAMILY DEVICES**



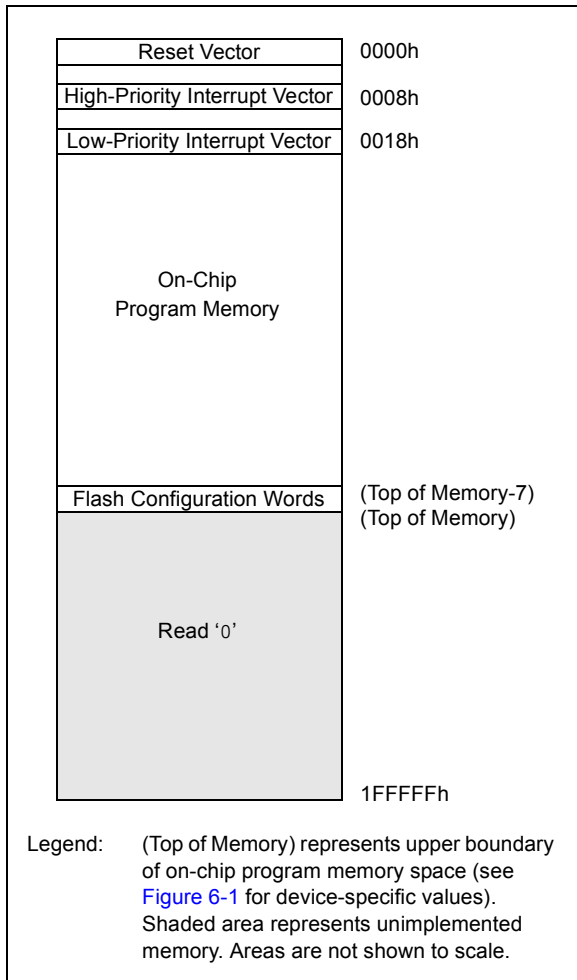
# PIC18F87J72

## 6.1.1 HARD MEMORY VECTORS

All PIC18 devices have a total of three hard-coded return vectors in their program memory space. The Reset vector address is the default value to which the program counter returns on all device Resets; it is located at 0000h.

PIC18 devices also have two interrupt vector addresses for the handling of high-priority and low-priority interrupts. The high-priority interrupt vector is located at 0008h and the low-priority interrupt vector is at 0018h. Their locations in relation to the program memory map are shown in [Figure 6-2](#).

**FIGURE 6-2: HARD VECTOR AND CONFIGURATION WORD LOCATIONS FOR PIC18F87J72 FAMILY DEVICES**



## 6.1.2 FLASH CONFIGURATION WORDS

Because PIC18F87J72 family devices do not have persistent configuration memory, the top four words of on-chip program memory are reserved for configuration information. On Reset, the configuration information is copied into the Configuration registers.

The Configuration Words are stored in their program memory location in numerical order, starting with the lower byte of CONFIG1 at the lowest address and ending with the upper byte of CONFIG4. For these devices, only Configuration Words, CONFIG1 through CONFIG3, are used; CONFIG4 is reserved. The actual addresses of the Flash Configuration Word for devices in the PIC18F87J72 family are shown in [Table 6-1](#). Their location in the memory map is shown with the other memory vectors in [Figure 6-2](#).

Additional details on the device Configuration Words are provided in [Section 26.1 "Configuration Bits"](#).

**TABLE 6-1: FLASH CONFIGURATION WORD FOR PIC18F87J72 FAMILY DEVICES**

Device	Program Memory (Kbytes)	Configuration Word Addresses
PIC18F86J72	64	FFF8h to FFFFh
PIC18F87J72	128	1FFF8h to 1FFFFh

## 6.1.3 PROGRAM COUNTER

The Program Counter (PC) specifies the address of the instruction to fetch for execution. The PC is 21 bits wide and is contained in three separate 8-bit registers. The low byte, known as the PCL register, is both readable and writable. The high byte, or PCH register, contains the PC<15:8> bits; it is not directly readable or writable. Updates to the PCH register are performed through the PCLATH register. The upper byte is called PCU. This register contains the PC<20:16> bits; it is also not directly readable or writable. Updates to the PCU register are performed through the PCLATU register.

The contents of PCLATH and PCLATU are transferred to the program counter by any operation that writes PCL. Similarly, the upper two bytes of the program counter are transferred to PCLATH and PCLATU by an operation that reads PCL. This is useful for computed offsets to the PC (see [Section 6.1.2.1 “Computed GOTO”](#)).

The PC addresses bytes in the program memory. To prevent the PC from becoming misaligned with word instructions, the Least Significant bit (LSb) of PCL is fixed to a value of ‘0’. The PC increments by 2 to address sequential instructions in the program memory.

The CALL, RCALL, GOTO and program branch instructions write to the program counter directly. For these instructions, the contents of PCLATH and PCLATU are not transferred to the program counter.

## 6.1.4 RETURN ADDRESS STACK

The return address stack allows any combination of up to 31 program calls and interrupts to occur. The PC is pushed onto the stack when a CALL or RCALL instruction is executed, or an interrupt is Acknowledged. The PC value is pulled off the stack on a RETURN, RETLW or a RETFIE instruction (and on ADDULNK and SUBULNK instructions if the extended instruction set is enabled). PCLATU and PCLATH are not affected by any of the RETURN or CALL instructions.

The stack operates as a 31-word by 21-bit RAM and a 5-bit Stack Pointer, STKPTR. The stack space is not part of either program or data space. The Stack Pointer is readable and writable and the address on the top of the stack is readable and writable through the Top-of-Stack Special Function Registers. Data can also be pushed to, or popped from the stack, using these registers.

A CALL type instruction causes a push onto the stack. The Stack Pointer is first incremented and the location pointed to by the Stack Pointer is written with the contents of the PC (already pointing to the instruction following the CALL). A RETURN type instruction causes a pop from the stack. The contents of the location pointed to by the STKPTR are transferred to the PC and then the Stack Pointer is decremented.

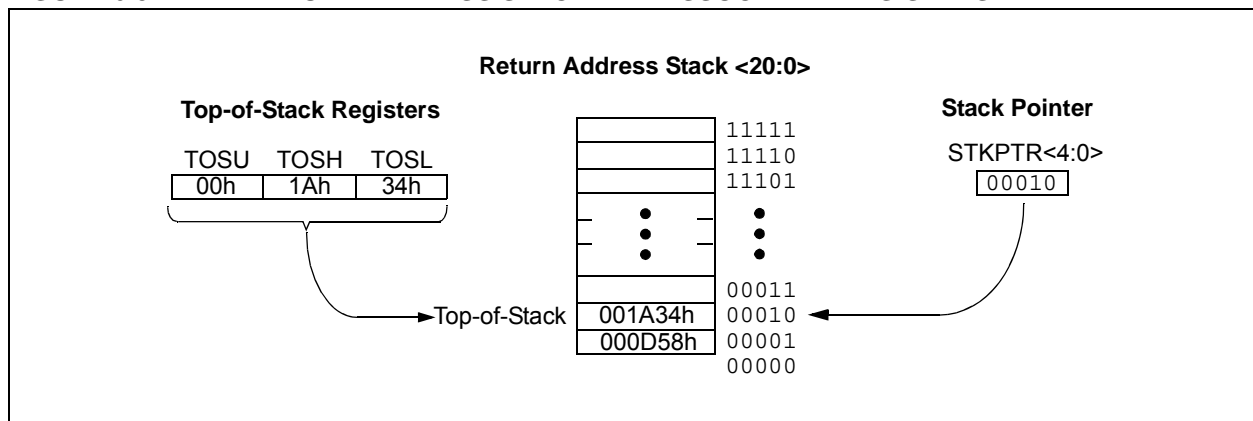
The Stack Pointer is initialized to ‘00000’ after all Resets. There is no RAM associated with the location corresponding to a Stack Pointer value of ‘00000’; this is only a Reset value. Status bits indicate if the stack is full, has overflowed or has underflowed.

### 6.1.4.1 Top-of-Stack Access

Only the top of the return address stack (TOS) is readable and writable. A set of three registers, TOSU:TOSH:TOSL, holds the contents of the stack location pointed to by the STKPTR register ([Figure 6-3](#)). This allows users to implement a software stack if necessary. After a CALL, RCALL or interrupt (and ADDULNK and SUBULNK instructions if the extended instruction set is enabled), the software can read the pushed value by reading the TOSU:TOSH:TOSL registers. These values can be placed on a user-defined software stack. At return time, the software can return these values to TOSU:TOSH:TOSL and do a return.

The user must disable the global interrupt enable bits while accessing the stack to prevent inadvertent stack corruption.

**FIGURE 6-3: RETURN ADDRESS STACK AND ASSOCIATED REGISTERS**



# PIC18F87J72

## 6.1.4.2 Return Stack Pointer (STKPTR)

The STKPTR register (Register 6-1) contains the Stack Pointer value, the STKFUL (Stack Full) Status bit and the STKUNF (Stack Underflow) Status bits. The value of the Stack Pointer can be 0 through 31. The Stack Pointer increments before values are pushed onto the stack and decrements after values are popped off the stack. On Reset, the Stack Pointer value will be zero. The user may read and write the Stack Pointer value. This feature can be used by a Real-Time Operating System (RTOS) for return stack maintenance.

After the PC is pushed onto the stack 31 times (without popping any values off the stack), the STKFUL bit is set. The STKFUL bit is cleared by software or by a POR.

The action that takes place when the stack becomes full depends on the state of the STVREN (Stack Overflow Reset Enable) Configuration bit. (Refer to Section 26.1 “Configuration Bits” for a description of the device Configuration bits.) If STVREN is set (default), the 31st push will push the (PC + 2) value onto the stack, set the STKFUL bit and reset the device. The STKFUL bit will remain set and the Stack Pointer will be set to zero.

If STVREN is cleared, the STKFUL bit will be set on the 31st push and the Stack Pointer will increment to 31. Any additional pushes will not overwrite the 31st push and the STKPTR will remain at 31.

When the stack has been popped enough times to unload the stack, the next pop will return a value of zero to the PC and set the STKUNF bit while the Stack Pointer remains at zero. The STKUNF bit will remain set until cleared by software or until a POR occurs.

**Note:** Returning a value of zero to the PC on an underflow has the effect of vectoring the program to the Reset vector, where the stack conditions can be verified and appropriate actions can be taken. This is not the same as a Reset, as the contents of the SFRs are not affected.

## 6.1.4.3 PUSH and POP Instructions

Since the Top-of-Stack is readable and writable, the ability to push values onto the stack and pull values off the stack, without disturbing normal program execution, is a desirable feature. The PIC18 instruction set includes two instructions, PUSH and POP, that permit the TOS to be manipulated under software control. TOSU, TOSH and TOSL can be modified to place data or a return address on the stack.

The PUSH instruction places the current PC value onto the stack. This increments the Stack Pointer and loads the current PC value onto the stack.

The POP instruction discards the current TOS by decrementing the Stack Pointer. The previous value pushed onto the stack then becomes the TOS value.

**REGISTER 6-1: STKPTR: STACK POINTER REGISTER**

R/C-0	R/C-0	U-0	R/W-0	R/W-0	R/W-0	R/W-0	R/W-0
STKFUL <sup>(1)</sup>	STKUNF <sup>(1)</sup>	—	SP4	SP3	SP2	SP1	SP0
bit 7							bit 0

Legend:	C = Clearable bit	U = Unimplemented bit, read as '0'
R = Readable bit	W = Writable bit	'0' = Bit is cleared
-n = Value at POR	'1' = Bit is set	x = Bit is unknown

- bit 7      **STKFUL:** Stack Full Flag bit<sup>(1)</sup>  
           1 = Stack became full or overflowed  
           0 = Stack has not become full or overflowed
- bit 6      **STKUNF:** Stack Underflow Flag bit<sup>(1)</sup>  
           1 = Stack underflow occurred  
           0 = Stack underflow did not occur
- bit 5      **Unimplemented:** Read as '0'
- bit 4-0    **SP<4:0>:** Stack Pointer Location bits

**Note 1:** Bit 7 and bit 6 are cleared by user software or by a POR.

## 6.1.0.1 Stack Full and Underflow Resets

Device Resets on stack overflow and stack underflow conditions are enabled by setting the STVREN bit in Configuration Register 1L. When STVREN is set, a full or underflow condition will set the appropriate STKFUL or STKUNF bit and then cause a device Reset. When STVREN is cleared, a full or underflow condition will set the appropriate STKFUL or STKUNF bit, but not cause a device Reset. The STKFUL or STKUNF bits are cleared by the user software or a Power-on Reset.

## 6.1.1 FAST REGISTER STACK

A Fast Register Stack is provided for the STATUS, WREG and BSR registers to provide a “fast return” option for interrupts. This stack is only one level deep and is neither readable nor writable. It is loaded with the current value of the corresponding register when the processor vectors for an interrupt. All interrupt sources will push values into the Stack registers. The values in the registers are then loaded back into the working registers if the RETFIE, FAST instruction is used to return from the interrupt.

If both low and high-priority interrupts are enabled, the Stack registers cannot be used reliably to return from low-priority interrupts. If a high-priority interrupt occurs while servicing a low-priority interrupt, the Stack register values stored by the low-priority interrupt will be overwritten. In these cases, users must save the key registers in software during a low-priority interrupt.

If interrupt priority is not used, all interrupts may use the Fast Register Stack for returns from interrupt. If no interrupts are used, the Fast Register Stack can be used to restore the STATUS, WREG and BSR registers at the end of a subroutine call. To use the Fast Register Stack for a subroutine call, a CALL label, FAST instruction must be executed to save the STATUS, WREG and BSR registers to the Fast Register Stack. A RETURN, FAST instruction is then executed to restore these registers from the Fast Register Stack.

[Example 6-1](#) shows a source code example that uses the Fast Register Stack during a subroutine call and return.

### EXAMPLE 6-1: FAST REGISTER STACK CODE EXAMPLE

```
CALL SUB1, FAST      ;STATUS, WREG, BSR
                    ;SAVED IN FAST REGISTER
                    ;STACK
    .
    .
SUB1    .
    .
        RETURN FAST  ;RESTORE VALUES SAVED
                    ;IN FAST REGISTER STACK
```

## 6.1.2 LOOK-UP TABLES IN PROGRAM MEMORY

There may be programming situations that require the creation of data structures, or look-up tables, in program memory. For PIC18 devices, look-up tables can be implemented in two ways:

- Computed GOTO
- Table Reads

### 6.1.2.1 Computed GOTO

A computed GOTO is accomplished by adding an offset to the program counter. An example is shown in [Example 6-2](#).

A look-up table can be formed with an ADDWF PCL instruction and a group of RETLW nn instructions. The W register is loaded with an offset into the table before executing a call to that table. The first instruction of the called routine is the ADDWF PCL instruction. The next instruction executed will be one of the RETLW nn instructions that returns the value ‘nn’ to the calling function.

The offset value (in WREG) specifies the number of bytes that the program counter should advance and should be multiples of 2 (LSb = 0).

In this method, only one data byte may be stored in each instruction location and room on the return address stack is required.

### EXAMPLE 6-2: COMPUTED GOTO USING AN OFFSET VALUE

```
MOVWF OFFSET, W
CALL TABLE
ORG nn00h
TABLE ADDWF PCL
      RETLW nnh
      RETLW nnh
      RETLW nnh
      .
      .
      .
```

### 6.1.2.2 Table Reads

A better method of storing data in program memory allows two bytes of data to be stored in each instruction location.

Look-up table data may be stored, two bytes per program word, while programming. The Table Pointer (TBLPTR) specifies the byte address and the Table Latch (TABLAT) contains the data that is read from the program memory. Data is transferred from program memory, one byte at a time.

Table read operation is discussed further in [Section 7.1 “Table Reads and Table Writes”](#).

# PIC18F87J72

## 6.2 PIC18 Instruction Cycle

### 6.2.1 CLOCKING SCHEME

The microcontroller clock input, whether from an internal or external source, is internally divided by four to generate four non-overlapping quadrature clocks (Q1, Q2, Q3 and Q4). Internally, the program counter is incremented on every Q1; the instruction is fetched from the program memory and latched into the Instruction Register (IR) during Q4. The instruction is decoded and executed during the following Q1 through Q4. The clocks and instruction execution flow are shown in Figure 6-1.

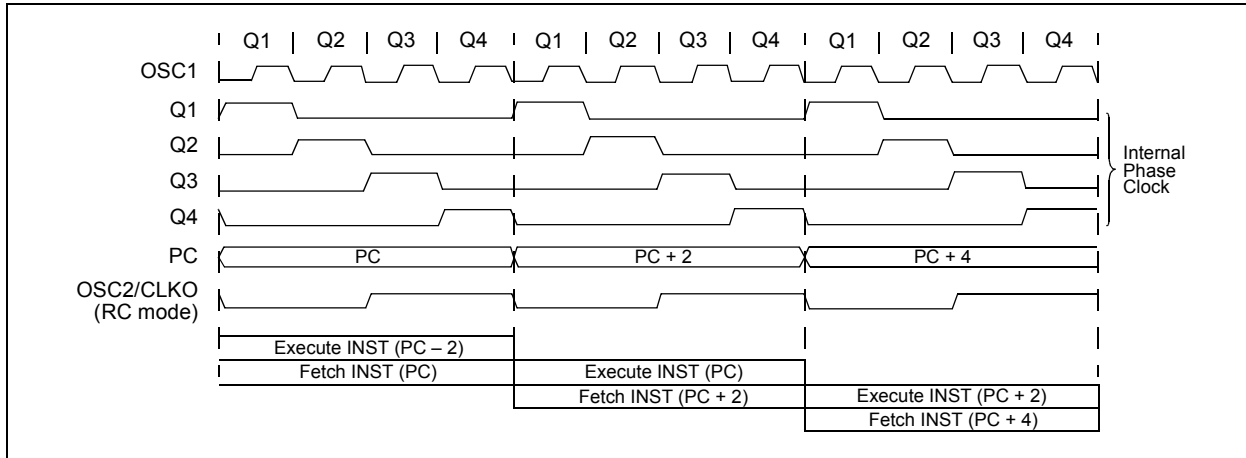
### 6.2.2 INSTRUCTION FLOW/PIPELINING

An “Instruction Cycle” consists of four Q cycles, Q1 through Q4. The instruction fetch and execute are pipelined in such a manner that a fetch takes one instruction cycle, while the decode and execute take another instruction cycle. However, due to the pipelining, each instruction effectively executes in one cycle. If an instruction causes the program counter to change (e.g., GOTO), then two cycles are required to complete the instruction (Example 6-3).

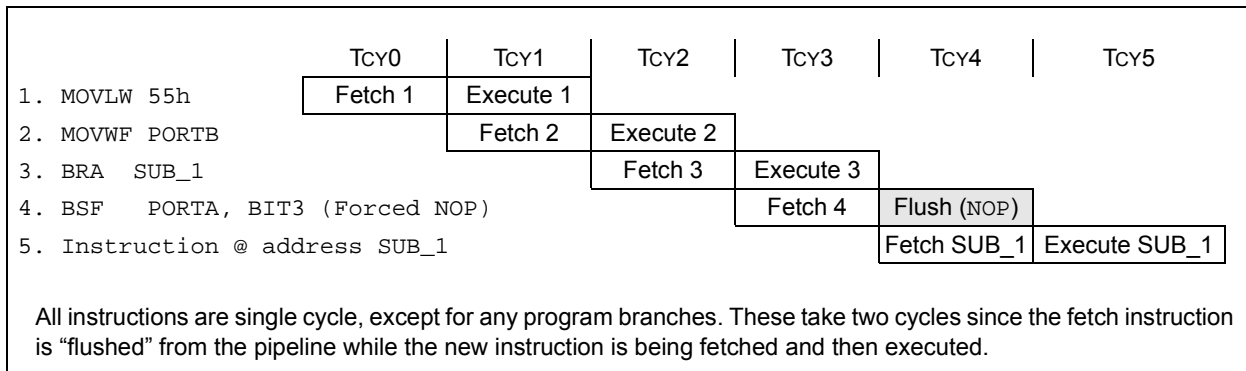
A fetch cycle begins with the Program Counter (PC) incrementing in Q1.

In the execution cycle, the fetched instruction is latched into the Instruction Register (IR) in cycle Q1. This instruction is then decoded and executed during the Q2, Q3 and Q4 cycles. Data memory is read during Q2 (operand read) and written during Q4 (destination write).

**FIGURE 6-1: CLOCK/INSTRUCTION CYCLE**



**EXAMPLE 6-3: INSTRUCTION PIPELINE FLOW**





## 6.2.3 INSTRUCTIONS IN PROGRAM MEMORY

The program memory is addressed in bytes. Instructions are stored as two bytes or four bytes in program memory. The Least Significant Byte (LSB) of an instruction word is always stored in a program memory location with an even address (LSB = 0). To maintain alignment with instruction boundaries, the PC increments in steps of 2 and the LSB will always read '0' (see [Section 6.1.3 "Program Counter"](#)).

[Figure 6-2](#) shows an example of how instruction words are stored in the program memory.

The CALL and GOTO instructions have the absolute program memory address embedded into the instruction. Since instructions are always stored on word boundaries, the data contained in the instruction is a word address. The word address is written to PC<20:1>, which accesses the desired byte address in program memory. Instruction #2 in [Figure 6-2](#) shows how the instruction, GOTO 0006h, is encoded in the program memory. Program branch instructions, which encode a relative address offset, operate in the same manner. The offset value stored in a branch instruction represents the number of single-word instructions that the PC will be offset by. [Section 27.0 "Instruction Set Summary"](#) provides further details of the instruction set.

**FIGURE 6-2: INSTRUCTIONS IN PROGRAM MEMORY**

Program Memory Byte Locations →			Word Address		
			LSB = 1	LSB = 0	
				000000h	
				000002h	
				000004h	
				000006h	
Instruction 1:	MOVLW	055h	0Fh	55h	000008h
Instruction 2:	GOTO	0006h	EFh	03h	00000Ah
			F0h	00h	00000Ch
Instruction 3:	MOVFF	123h, 456h	C1h	23h	00000Eh
			F4h	56h	000010h
					000012h
					000014h

## 6.2.4 TWO-WORD INSTRUCTIONS

The standard PIC18 instruction set has four two-word instructions: CALL, MOVFF, GOTO and LSFR. In all cases, the second word of the instructions always has '1111' as its four Most Significant bits; the other 12 bits are literal data, usually a data memory address.

The use of '1111' in the 4 MSBs of an instruction specifies a special form of NOP. If the instruction is executed in proper sequence – immediately after the first word – the data in the second word is accessed and used by the instruction sequence.

If the first word is skipped for some reason and the second word is executed by itself, a NOP is executed instead. This is necessary for cases when the two-word instruction is preceded by a conditional instruction that changes the PC. [Example 6-4](#) shows how this works.

**Note:** See [Section 6.4 "Program Memory and the Extended Instruction Set"](#) for information on two-word instructions in the extended instruction set.

**EXAMPLE 6-4: TWO-WORD INSTRUCTIONS**

CASE 1:		
Object Code	Source Code	
0110 0110 0000 0000	TSTFSZ	REG1 ; is RAM location 0?
1100 0001 0010 0011	MOVFF	REG1, REG2 ; No, skip this word
1111 0100 0101 0110		; Execute this word as a NOP
0010 0100 0000 0000	ADDWF	REG3 ; continue code
CASE 2:		
Object Code	Source Code	
0110 0110 0000 0000	TSTFSZ	REG1 ; is RAM location 0?
1100 0001 0010 0011	MOVFF	REG1, REG2 ; Yes, execute this word
1111 0100 0101 0110		; 2nd word of instruction
0010 0100 0000 0000	ADDWF	REG3 ; continue code

# PIC18F87J72

## 6.3 Data Memory Organization

**Note:** The operation of some aspects of data memory are changed when the PIC18 extended instruction set is enabled. See [Section 6.5 “Data Memory and the Extended Instruction Set”](#) for more information.

The data memory in PIC18 devices is implemented as static RAM. Each register in the data memory has a 12-bit address, allowing up to 4,096 bytes of data memory. The memory space is divided into as many as 16 banks that contain 256 bytes each. PIC18F86J72 and PIC18F87J72 devices implement all 16 complete banks, for a total of 4 Kbytes. [Figure 6-3](#) and [Figure 6-4](#) show the data memory organization for the devices.

The data memory contains Special Function Registers (SFRs) and General Purpose Registers (GPRs). The SFRs are used for control and status of the controller and peripheral functions, while GPRs are used for data storage and scratchpad operations in the user's application. Any read of an unimplemented location will read as '0's.

The instruction set and architecture allow operations across all banks. The entire data memory may be accessed by Direct, Indirect or Indexed Addressing modes. Addressing modes are discussed later in this section.

To ensure that commonly used registers (select SFRs and select GPRs) can be accessed in a single cycle, PIC18 devices implement an Access Bank. This is a 256-byte memory space that provides fast access to select SFRs and the lower portion of GPR Bank 0 without using the BSR. [Section 6.3.2 “Access Bank”](#) provides a detailed description of the Access RAM.

### 6.3.1 BANK SELECT REGISTER

Large areas of data memory require an efficient addressing scheme to make rapid access to any address possible. Ideally, this means that an entire address does not need to be provided for each read or write operation. For PIC18 devices, this is accomplished with a RAM banking scheme. This divides the memory space into 16 contiguous banks of 256 bytes. Depending on the instruction, each location can be addressed directly by its full 12-bit address, or an 8-bit low-order address and a 4-bit Bank Pointer.

Most instructions in the PIC18 instruction set make use of the Bank Pointer, known as the Bank Select Register (BSR). This SFR holds the four Most Significant bits of a location's address; the instruction itself includes the eight Least Significant bits. Only the four lower bits of the BSR are implemented (BSR<3:0>). The upper four bits are unused; they will always read '0' and cannot be written to. The BSR can be loaded directly by using the `MOVLB` instruction.

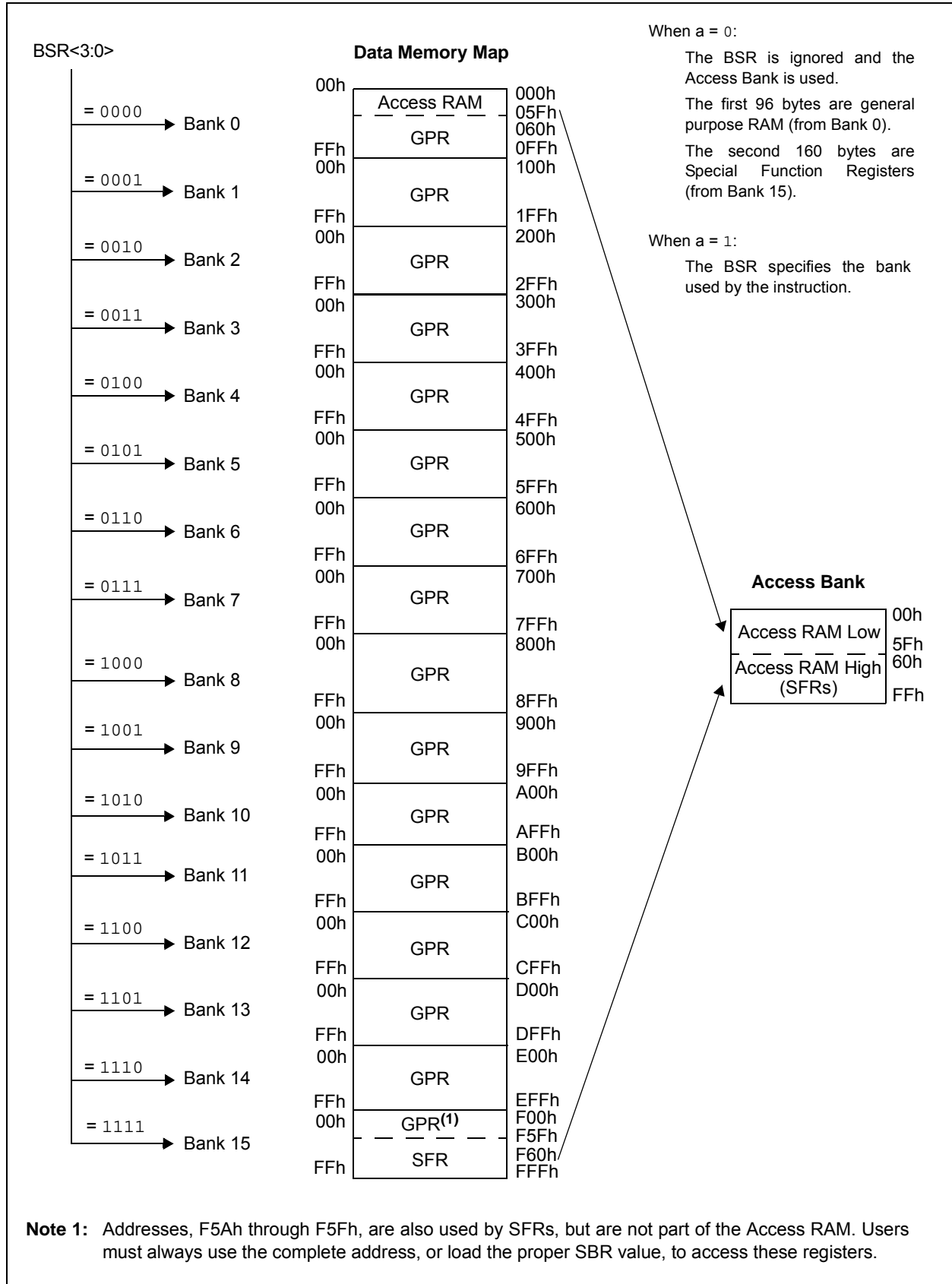
The value of the BSR indicates the bank in data memory. The eight bits in the instruction show the location in the bank and can be thought of as an offset from the bank's lower boundary. The relationship between the BSR's value and the bank division in data memory is shown in [Figure 6-4](#).

Since up to 16 registers may share the same low-order address, the user must always be careful to ensure that the proper bank is selected before performing a data read or write. For example, writing what should be program data to an 8-bit address of F9h while the BSR is 0Fh, will end up resetting the program counter.

While any bank can be selected, only those banks that are actually implemented can be read or written to. Writes to unimplemented banks are ignored, while reads from unimplemented banks will return '0's. Even so, the STATUS register will still be affected as if the operation was successful. The data memory map in [Figure 6-3](#) indicates which banks are implemented.

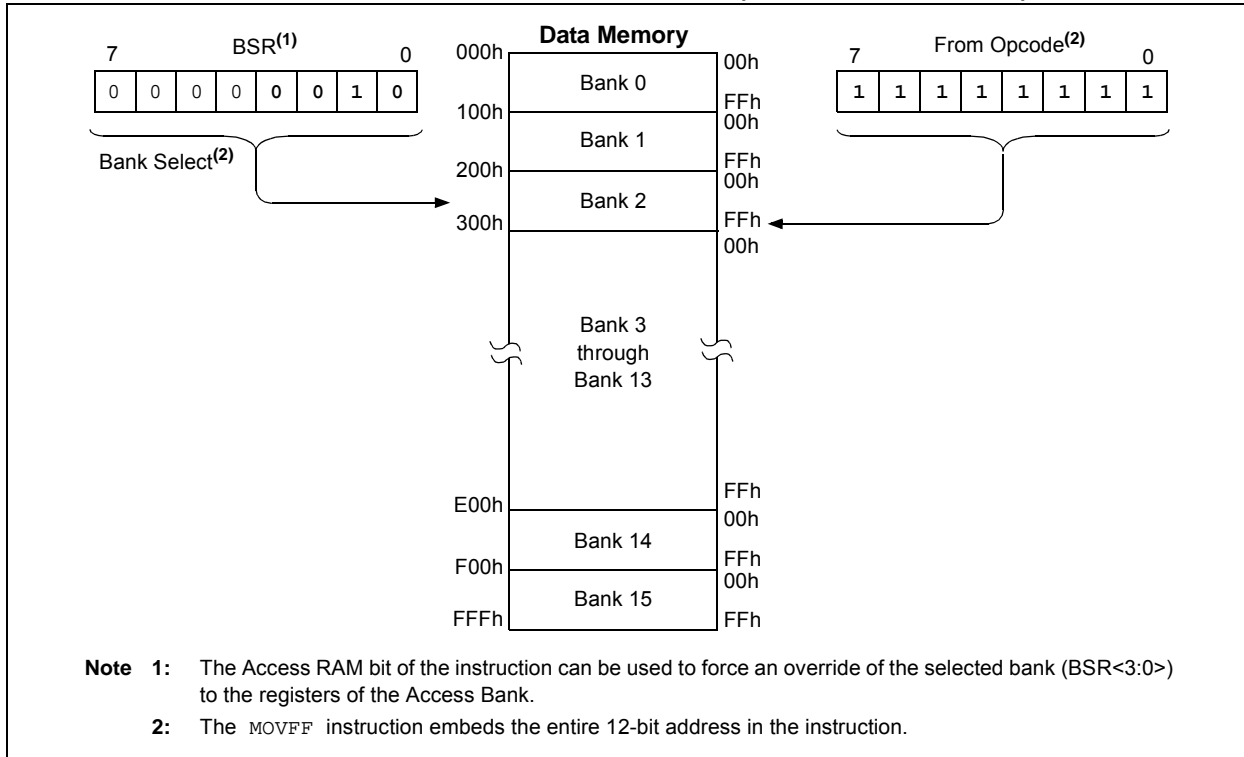
In the core PIC18 instruction set, only the `MOVFF` instruction fully specifies the 12-bit address of the source and target registers. This instruction ignores the BSR completely when it executes. All other instructions include only the low-order address as an operand and must use either the BSR or the Access Bank to locate their target registers.

**FIGURE 6-3: DATA MEMORY MAP FOR PIC18F86J72 AND PIC18F87J72 DEVICES**



# PIC18F87J72

**FIGURE 6-4: USE OF THE BANK SELECT REGISTER (DIRECT ADDRESSING)**



## 6.3.2 ACCESS BANK

While the use of the BSR with an embedded 8-bit address allows users to address the entire range of data memory, it also means that the user must always ensure that the correct bank is selected. Otherwise, data may be read from, or written to, the wrong location. This can be disastrous if a GPR is the intended target of an operation, but an SFR is written to instead. Verifying and/or changing the BSR for each read or write to data memory can become very inefficient.

To streamline access for the most commonly used data memory locations, the data memory is configured with an Access Bank, which allows users to access a mapped block of memory without specifying a BSR. The Access Bank consists of the first 96 bytes of memory (00h-5Fh) in Bank 0 and the last 160 bytes of memory (60h-FFh) in Bank 15. The lower half is known as the “Access RAM” and is composed of GPRs. The upper half is where the device’s SFRs are mapped. These two areas are mapped contiguously in the Access Bank and can be addressed in a linear fashion by an 8-bit address (Figure 6-3).

The Access Bank is used by core PIC18 instructions that include the Access RAM bit (the ‘a’ parameter in the instruction). When ‘a’ is equal to ‘1’, the instruction uses the BSR and the 8-bit address included in the opcode for the data memory address. When ‘a’ is ‘0’, however, the instruction is forced to use the Access Bank address map; the current value of the BSR is ignored entirely.

Using this “forced” addressing allows the instruction to operate on a data address in a single cycle without updating the BSR first. For 8-bit addresses of 60h and above, this means that users can evaluate and operate on SFRs more efficiently. The Access RAM below 60h is a good place for data values that the user might need to access rapidly, such as immediate computational results or common program variables. Access RAM also allows for faster and more code efficient context saving and switching of variables.

The mapping of the Access Bank is slightly different when the extended instruction set is enabled (XINST Configuration bit = 1). This is discussed in more detail in [Section 6.5.3 “Mapping the Access Bank in Indexed Literal Offset Mode”](#).

## 6.3.3 GENERAL PURPOSE REGISTER FILE

PIC18 devices may have banked memory in the GPR area. This is data RAM which is available for use by all instructions. GPRs start at the bottom of Bank 0 (address 000h) and grow upwards towards the bottom of the SFR area. GPRs are not initialized by a Power-on Reset and are unchanged on all other Resets.

## 6.3.4 SPECIAL FUNCTION REGISTERS

The Special Function Registers (SFRs) are registers used by the CPU and peripheral modules for controlling the desired operation of the device. These registers are implemented as static RAM. SFRs start at the top of data memory (FFFh) and extend downward to occupy more than the top half of Bank 15 (F60h to FFFh). A list of these registers is given in [Table 6-1](#) and [Table 6-2](#).

The SFRs can be classified into two sets: those associated with the “core” device functionality (ALU, Resets and interrupts) and those related to the peripheral functions. The Reset and Interrupt registers are described in their respective chapters, while the ALU’s STATUS register is described later in this section. Registers related to the operation of the peripheral features are described in the chapter for that peripheral.

The SFRs are typically distributed among the peripherals whose functions they control. Unused SFR locations are unimplemented and read as ‘0’s.

**TABLE 6-1: SPECIAL FUNCTION REGISTER MAP FOR PIC18F87J72 FAMILY DEVICES**

Addr.	Name	Addr.	Name	Addr.	Name	Addr.	Name	Addr.	Name	Addr.	Name
FFFh	TOSU	FDfH	INDF2 <sup>(1)</sup>	FBFh	LCDDATA4	F9Fh	IPR1	F7Fh	SPBRGH1	F5Fh	RTCCFG
FFEh	TOSH	FDEh	POSTINC2 <sup>(1)</sup>	FBEh	LCDDATA3	F9Eh	PIR1	F7Eh	BAUDCON1	F5Eh	RTCCAL
FFDh	TOSL	FDDh	POSTDEC2 <sup>(1)</sup>	FBDh	LCDDATA2	F9Dh	PIE1	F7Dh	__ <sup>(2)</sup>	F5Dh	RTCVALH
FFCh	STKPTR	FDCh	PREINC2 <sup>(1)</sup>	FBCh	LCDDATA1	F9Ch	__ <sup>(2)</sup>	F7Ch	LCDDATA22	F5Ch	RTCVALL
FFBh	PCLATU	FDBh	PLUSW2 <sup>(1)</sup>	FBBh	LCDDATA0	F9Bh	OSCTUNE	F7Bh	LCDDATA21	F5Bh	ALRMCFG
FFAh	PCLATH	FDAh	FSR2H	FBAh	__ <sup>(2)</sup>	F9Ah	TRISJ	F7Ah	LCDDATA20	F5Ah	ALRMRPT
FF9h	PCL	FD9h	FSR2L	FB9h	LCDSE4	F99h	TRISH	F79h	LCDDATA19	F59h	ALRMVALH
FF8h	TBLPTRU	FD8h	STATUS	FB8h	LCDSE3	F98h	TRISG	F78h	LCDDATA18	F58h	ALRMVALL
FF7h	TBLPTRH	FD7h	TMR0H	FB7h	LCDSE2	F97h	TRISF	F77h	__ <sup>(2)</sup>	F57h	CTMUCONH
FF6h	TBLPTRL	FD6h	TMR0L	FB6h	LCDSE1	F96h	TRISE	F76h	LCDDATA16	F56h	CTMUCONL
FF5h	TABLAT	FD5h	T0CON	FB5h	CVRCON	F95h	TRISD	F75h	LCDDATA15	F55h	CTMUICONH
FF4h	PRODH	FD4h	__ <sup>(2)</sup>	FB4h	CMCON	F94h	TRISC	F74h	LCDDATA14	F54h	PADCFG1
FF3h	PRODL	FD3h	OSCCON	FB3h	TMR3H	F93h	TRISB	F73h	LCDDATA13		
FF2h	INTCON	FD2h	LCDREG	FB2h	TMR3L	F92h	TRISA	F72h	LCDDATA12		
FF1h	INTCON2	FD1h	WDTCON	FB1h	T3CON	F91h	LATJ	F71h	__ <sup>(2)</sup>		
FF0h	INTCON3	FD0h	RCON	FB0h	__ <sup>(2)</sup>	F90h	LATH	F70h	LCDDATA10		
FEFh	INDF0 <sup>(1)</sup>	FCFh	TMR1H	FAFh	SPBRG1	F8Fh	LATG	F6Fh	LCDDATA9		
FEeh	POSTINC0 <sup>(1)</sup>	FCEh	TMR1L	FAEh	RCREG1	F8Eh	LATF	F6Eh	LCDDATA8		
FEDh	POSTDEC0 <sup>(1)</sup>	FCDh	T1CON	FADh	TXREG1	F8Dh	LATE	F6Dh	LCDDATA7		
FECh	PREINC0 <sup>(1)</sup>	FCCh	TMR2	FACH	TXSTA1	F8Ch	LATD	F6Ch	LCDDATA6		
FEBh	PLUSW0 <sup>(1)</sup>	FCBh	PR2	FABh	RCSTA1	F8Bh	LATC	F6Bh	__ <sup>(2)</sup>		
FEAh	FSR0H	FCAh	T2CON	FAAh	LCDPS	F8Ah	LATB	F6Ah	CCPR1H		
FE9h	FSR0L	FC9h	SSPBUF	FA9h	LCDSE0	F89h	LATA	F69h	CCPR1L		
FE8h	WREG	FC8h	SSPADD	FA8h	LCDCON	F88h	PORTJ	F68h	CCP1CON		
FE7h	INDF1 <sup>(1)</sup>	FC7h	SSPSTAT	FA7h	EECON2	F87h	PORTH	F67h	CCPR2H		
FE6h	POSTINC1 <sup>(1)</sup>	FC6h	SSPCON1	FA6h	EECON1	F86h	PORTG	F66h	CCPR2L		
FE5h	POSTDEC1 <sup>(1)</sup>	FC5h	SSPCON2	FA5h	IPR3	F85h	PORTF	F65h	CCP2CON		
FE4h	PREINC1 <sup>(1)</sup>	FC4h	ADRESH	FA4h	PIR3	F84h	PORTE	F64h	SPBRG2		
FE3h	PLUSW1 <sup>(1)</sup>	FC3h	ADRESL	FA3h	PIE3	F83h	PORTD	F63h	RCREG2		
FE2h	FSR1H	FC2h	ADCON0	FA2h	IPR2	F82h	PORTC	F62h	TXREG2		
FE1h	FSR1L	FC1h	ADCON1	FA1h	PIR2	F81h	PORTB	F61h	TXSTA2		
FE0h	BSR	FC0h	ADCON2	FA0h	PIE2	F80h	PORTA	F60h	RCSTA2		

**Note 1:** This is not a physical register.  
**Note 2:** Unimplemented registers are read as ‘0’.

# PIC18F87J72

**TABLE 6-2: PIC18F87J72 FAMILY REGISTER FILE SUMMARY**

File Name	Bit 7	Bit 6	Bit 5	Bit 4	Bit 3	Bit 2	Bit 1	Bit 0	Value on POR, BOR	Details on page	
TOSU	—	—	—	Top-of-Stack Upper Byte (TOS<20:16>)				---	0000	45, 53	
TOSH	Top-of-Stack High Byte (TOS<15:8>)							0000	0000	45, 53	
TOSL	Top-of-Stack Low Byte (TOS<7:0>)							0000	0000	45, 53	
STKPTR	STKFUL	STKUNF	—	Return Stack Pointer				uu-	0000	45, 54	
PCLATU	—	—	bit 21 <sup>(1)</sup>	Holding Register for PC<20:16>				---	0000	45, 53	
PCLATH	Holding Register for PC<15:8>							0000	0000	45, 53	
PCL	PC Low Byte (PC<7:0>)							0000	0000	45, 53	
TBLPTRU	—	—	bit 21	Program Memory Table Pointer Upper Byte (TBLPTR<20:16>)				--	0000	45, 76	
TBLPTRH	Program Memory Table Pointer High Byte (TBLPTR<15:8>)							0000	0000	45, 76	
TBLPTRL	Program Memory Table Pointer Low Byte (TBLPTR<7:0>)							0000	0000	45, 76	
TABLAT	Program Memory Table Latch							0000	0000	45, 76	
PRODH	Product Register High Byte							xxxx	xxxx	45, 83	
PRODL	Product Register Low Byte							xxxx	xxxx	45, 83	
INTCON	GIE/GIEH	PEIE/GIEL	TMR0IE	INT0IE	RBIE	TMR0IF	INT0IF	RBIF	0000 000x	45, 87	
INTCON2	RBPU	INTEDG0	INTEDG1	INTEDG2	INTEDG3	TMR0IP	INT3IP	RBIP	1111 1111	45, 88	
INTCON3	INT2IP	INT1IP	INT3IE	INT2IE	INT1IE	INT3IF	INT2IF	INT1IF	1100 0000	45, 89	
INDF0	Uses contents of FSR0 to address data memory – value of FSR0 not changed (not a physical register)							N/A		45, 68	
POSTINC0	Uses contents of FSR0 to address data memory – value of FSR0 post-incremented (not a physical register)							N/A		45, 69	
POSTDEC0	Uses contents of FSR0 to address data memory – value of FSR0 post-decremented (not a physical register)							N/A		45, 69	
PREINC0	Uses contents of FSR0 to address data memory – value of FSR0 pre-incremented (not a physical register)							N/A		45, 69	
PLUSW0	Uses contents of FSR0 to address data memory – value of FSR0 pre-incremented (not a physical register) – value of FSR0 offset by W							N/A		45, 69	
FSR0H	—	—	—	—	Indirect Data Memory Address Pointer 0 High Byte				----	xxxxx	45, 68
FSR0L	Indirect Data Memory Address Pointer 0 Low Byte							xxxxx	xxxxx	45, 68	
WREG	Working Register							xxxxx	xxxxx	45	
INDF1	Uses contents of FSR1 to address data memory – value of FSR1 not changed (not a physical register)							N/A		45, 68	
POSTINC1	Uses contents of FSR1 to address data memory – value of FSR1 post-incremented (not a physical register)							N/A		45, 69	
POSTDEC1	Uses contents of FSR1 to address data memory – value of FSR1 post-decremented (not a physical register)							N/A		45, 69	
PREINC1	Uses contents of FSR1 to address data memory – value of FSR1 pre-incremented (not a physical register)							N/A		45, 69	
PLUSW1	Uses contents of FSR1 to address data memory – value of FSR1 pre-incremented (not a physical register) – value of FSR1 offset by W							N/A		45, 69	
FSR1H	—	—	—	—	Indirect Data Memory Address Pointer 1 High Byte				----	xxxxx	46, 68
FSR1L	Indirect Data Memory Address Pointer 1 Low Byte							xxxxx	xxxxx	46, 68	
BSR	—	—	—	—	Bank Select Register				----	0000	46, 58
INDF2	Uses contents of FSR2 to address data memory – value of FSR2 not changed (not a physical register)							N/A		46, 68	
POSTINC2	Uses contents of FSR2 to address data memory – value of FSR2 post-incremented (not a physical register)							N/A		46, 69	
POSTDEC2	Uses contents of FSR2 to address data memory – value of FSR2 post-decremented (not a physical register)							N/A		46, 69	
PREINC2	Uses contents of FSR2 to address data memory – value of FSR2 pre-incremented (not a physical register)							N/A		46, 69	
PLUSW2	Uses contents of FSR2 to address data memory – value of FSR2 pre-incremented (not a physical register) – value of FSR2 offset by W							N/A		46, 69	
FSR2H	—	—	—	—	Indirect Data Memory Address Pointer 2 High Byte				----	xxxxx	46, 68
FSR2L	Indirect Data Memory Address Pointer 2 Low Byte							xxxxx	xxxxx	46, 68	
STATUS	—	—	—	N	OV	Z	DC	C	---x	xxxxx	46, 66

Legend: x = unknown, u = unchanged, - = unimplemented, q = value depends on condition, r = reserved, do not modify

**Note 1:** Bit 21 of the PC is only available in Test mode and Serial Programming modes.

**Note 2:** Alternate names and definitions for these bits when the MSSP module is operating in I<sup>2</sup>C Slave mode. See [Section 18.4.3.2 “Address Masking”](#) for details.

**Note 3:** The PLEN bit is only available in specific oscillator configurations; otherwise, it is disabled and reads as ‘0’. See [Section 3.4.3 “PLL Frequency Multiplier”](#) for details.

**Note 4:** RA<7:6> and their associated latch and direction bits are configured as port pins only when the internal oscillator is selected as the default clock source (FOSC2 Configuration bit = 0); otherwise, they are disabled and these bits read as ‘0’.

**TABLE 6-2: PIC18F87J72 FAMILY REGISTER FILE SUMMARY (CONTINUED)**

File Name	Bit 7	Bit 6	Bit 5	Bit 4	Bit 3	Bit 2	Bit 1	Bit 0	Value on POR, BOR	Details on page
TMR0H	Timer0 Register High Byte								0000 0000	46, 122
TMR0L	Timer0 Register Low Byte								xxxx xxxx	46, 122
T0CON	TMR0ON	T08BIT	T0CS	T0SE	PSA	T0PS2	T0PS1	T0PS0	1111 1111	46, 120
OSCCON	IDLEN	IRCF2	IRCF1	IRCF0	OSTS	IOFS	SCS1	SCS0	0110 q000	24, 46
LCDREG	—	CPEN	BIAS2	BIAS1	BIAS0	MODE13	CKSEL1	CKSEL0	-011 1100	46, 166
WDTCON	REGSLP	—	—	—	—	—	—	SWDTEN	0--- --0	46, 315
RCON	IPEN	—	CM	RI	TO	PD	POR	BOR	0-11 11q0	40, 46
TMR1H	Timer1 Register High Byte								xxxx xxxx	46, 128
TMR1L	Timer1 Register Low Byte								xxxx xxxx	46, 128
T1CON	RD16	T1RUN	T1CKPS1	T1CKPS0	T1OSCEN	T1SYN $\bar{C}$	TMR1CS	TMR1ON	0000 0000	46, 123
TMR2	Timer2 Register								0000 0000	46, 130
PR2	Timer2 Period Register								1111 1111	46, 130
T2CON	—	T2OUTPS3	T2OUTPS2	T2OUTPS1	T2OUTPS0	TMR2ON	T2CKPS1	T2CKPS0	-000 0000	46, 129
SSPBUF	MSSP Receive Buffer/Transmit Register								xxxx xxxx	46, 195, 230
SSPADD	MSSP Address Register in I <sup>2</sup> C Slave mode. MSSP1 Baud Rate Reload Register in I <sup>2</sup> C Master mode.								0000 0000	46, 230
SSPSTAT	SMP	CKE	D/ $\bar{A}$	P	S	R/ $\bar{W}$	UA	BF	0000 0000	46, 188, 197
SSPCON1	WCOL	SSPOV	SSPEN	CKP	SSPM3	SSPM2	SSPM1	SSPM0	0000 0000	46, 189, 198
SSPCON2	GCEN	ACKSTAT	ACKDT	ACKEN	RCEN	PEN	RSEN	SEN	0000 0000	46, 199, 200
	GCEN	ACKSTAT	ADMSK5 <sup>(2)</sup>	ADMSK4 <sup>(2)</sup>	ADMSK3 <sup>(2)</sup>	ADMSK2 <sup>(2)</sup>	ADMSK1 <sup>(2)</sup>	SEN		
ADRESH	A/D Result Register High Byte								xxxx xxxx	47, 274
ADRESL	A/D Result Register Low Byte								xxxx xxxx	47, 274
ADCON0	ADCAL	—	CHS3	CHS2	CHS1	CHS0	GO/ $\bar{D}$ ONE	ADON	0-00 0000	47, 266
ADCON1	TRIGSEL	—	VCFG1	VCFG0	PCFG3	PCFG2	PCFG1	PCFG0	0-00 0000	47, 267
ADCON2	ADFM	—	ACQT2	ACQT1	ACQT0	ADCS2	ADCS1	ADCS0	0-00 0000	47, 268
LCDDATA4	—	—	—	—	—	—	—	S32C0	xxxx xxxx	47, 164
LCDDATA3	S31C0	S30C0	S29C0	S28C0	S27C0	S26C0	S25C0	S24C0	xxxx xxxx	47, 164
LCDDATA2	S23C0	S22C0	S21C0	S20C0	S19C0	S18C0	S17C0	S16C0	xxxx xxxx	47, 164
LCDDATA1	S15C0	S14C0	S13C0	S12C0	S11C0	S10C0	S09C0	S08C0	xxxx xxxx	47, 164
LCDDATA0	S07C0	S06C0	S05C0	S04C0	S03C0	S02C0	S01C0	S00C0	xxxx xxxx	47, 164
LCDSE4	—	—	—	—	—	—	—	SE32	0000 0000	47, 164
LCDSE3	SE31	SE30	SE29	SE28	SE27	SE26	SE25	SE24	0000 0000	47, 164
LCDSE2	SE23	SE22	SE21	SE20	SE19	SE18	SE17	SE16	0000 0000	47, 164
LCDSE1	SE15	SE14	SE13	SE12	SE11	SE10	SE09	SE08	0000 0000	47, 164
CVRCON	CVREN	CVROE	CVRR	CVRSS	CVR3	CVR2	CVR1	CVR0	0000 0000	47, 290
CMCON	C2OUT	C1OUT	C2INV	C1INV	CIS	CM2	CM1	CM0	0000 0111	47, 285
TMR3H	Timer3 Register High Byte								xxxx xxxx	47, 133
TMR3L	Timer3 Register Low Byte								xxxx xxxx	47, 133
T3CON	RD16	T3CCP2	T3CKPS1	T3CKPS0	T3CCP1	T3SYN $\bar{C}$	TMR3CS	TMR3ON	0000 0000	47, 131

Legend: x = unknown, u = unchanged, - = unimplemented, q = value depends on condition, r = reserved, do not modify

**Note 1:** Bit 21 of the PC is only available in Test mode and Serial Programming modes.

**2:** Alternate names and definitions for these bits when the MSSP module is operating in I<sup>2</sup>C Slave mode. See [Section 18.4.3.2 "Address Masking"](#) for details.

**3:** The PLEN bit is only available in specific oscillator configurations; otherwise, it is disabled and reads as '0'. See [Section 3.4.3 "PLL Frequency Multiplier"](#) for details.

**4:** RA<7:6> and their associated latch and direction bits are configured as port pins only when the internal oscillator is selected as the default clock source (FOSC2 Configuration bit = 0); otherwise, they are disabled and these bits read as '0'.

# PIC18F87J72

**TABLE 6-2: PIC18F87J72 FAMILY REGISTER FILE SUMMARY (CONTINUED)**

File Name	Bit 7	Bit 6	Bit 5	Bit 4	Bit 3	Bit 2	Bit 1	Bit 0	Value on POR, BOR	Details on page
SPBRG1	EUSART Baud Rate Generator Low Byte								0000 0000	47, 236
RCREG1	EUSART Receive Register								0000 0000	47, 244
TXREG1	EUSART Transmit Register								0000 0000	47, 242
TXSTA1	CSRC	TX9	TXEN	SYNC	SENDB	BRGH	TRMT	TX9D	0000 0010	47, 232
RCSTA1	SPEN	RX9	SREN	CREN	ADDEN	FERR	OERR	RX9D	0000 000x	47, 233
LCDPS	WFT	BIASMD	LCDA	WA	LP3	LP2	LP1	LP0	0000 0000	47, 162
LCDSE0	SE07	SE06	SE05	SE04	SE03	SE02	SE01	SE00	0000 0000	47, 163
LCDCON	LCDEN	SLPEN	WERR	—	CS1	CS0	LMUX1	LMUX0	000- 0000	47, 161
EECON2	EEPROM Control Register 2 (not a physical register)								---- ----	47, 74
EECON1	—	—	WPROG	FREE	WRERR	WREN	WR	—	--00 x00-	47, 74
IPR3	—	LCDIP	RC2IP	TX2IP	CTMUIP	CCP2IP	CCP1IP	RTCCIP	-111 1111	48, 98
PIR3	—	LCDIF	RC2IF	TX2IF	CTMUIF	CCP2IF	CCP1IF	RTCCIF	-000 0000	48, 92
PIE3	—	LCDIE	RC2IE	TX2IE	CTMUIE	CCP2IE	CCP1IE	RTCCIE	-000 0000	48, 95
IPR2	OSCFIP	CMIP	—	—	BCLIP	LVDIP	TMR3IP	—	11-- 111-	48, 97
PIR2	OSCFIF	CMIF	—	—	BCLIF	LVDIF	TMR3IF	—	00-- 000-	48, 91
PIE2	OSCFIE	CMIE	—	—	BCLIE	LVDIE	TMR3IE	—	00-- 000-	48, 94
IPR1	—	ADIP	RC1IP	TX1IP	SSPIP	—	TMR2IP	TMR1IP	-111 1-11	48, 96
PIR1	—	ADIF	RC1IF	TX1IF	SSPIF	—	TMR2IF	TMR1IF	-000 0-00	48, 90
PIE1	—	ADIE	RC1IE	TX1IE	SSPIE	—	TMR2IE	TMR1IE	-000 0-00	48, 93
OSCTUNE	INTSRC	PLLEN <sup>(3)</sup>	TUN5	TUN4	TUN3	TUN2	TUN1	TUN0	0000 0000	25, 48
TRISG	SPIOD	CCP2OD	CCP1OD	TRISG4	TRISG3	TRISG2	TRISG1	TRISG0	0001 1111	48, 119
TRISF	TRISF7	TRISF6	TRISF5	TRISF4	TRISF3	TRISF2	TRISF1	—	1111 111-	48, 117
TRISE	TRISE7	TRISE6	TRISE5	TRISE4	TRISE3	—	TRISE1	TRISE0	1111 1-11	48, 114
TRISD	TRISD7	TRISD6	TRISD5	TRISD4	TRISD3	TRISD2	TRISD1	TRISD0	1111 1111	48, 112
TRISC	TRISC7	TRISC6	TRISC5	TRISC4	TRISC3	TRISC2	TRISC1	TRISC0	1111 1111	48, 110
TRISB	TRISB7	TRISB6	TRISB5	TRISB4	TRISB3	TRISB2	TRISB1	TRISB0	1111 1111	48, 107
TRISA	TRISA7 <sup>(4)</sup>	TRISA6 <sup>(4)</sup>	TRISA5	TRISA4	TRISA3	TRISA2	TRISA1	TRISA0	1111 1111	48, 104
LATG	U2OD	U1OD	—	LATG4	LATG3	LATG2	LATG1	LATG0	00-x xxxxx	48, 119
LATF	LATF7	LATF6	LATF5	LATF4	LATF3	LATF2	LATF1	—	xxxx xxx-	48, 117
LATE	LATE7	LATE6	LATE5	LATE4	LATE3	—	LATE1	LATE0	xxxx x-xx	48, 114
LATD	LATD7	LATD6	LATD5	LATD4	LATD3	LATD2	LATD1	LATD0	xxxx xxxxx	48, 112
LATC	LATC7	LATC6	LATC5	LATC4	LATC3	LATC2	LATC1	LATC0	xxxx xxxxx	48, 110
LATB	LATB7	LATB6	LATB5	LATB4	LATB3	LATB2	LATB1	LATB0	xxxx xxxxx	48, 107
LATA	LATA7 <sup>(4)</sup>	LATA6 <sup>(4)</sup>	LATA5	LATA4	LATA3	LATA2	LATA1	LATA0	xxxx xxxxx	48, 104
PORTG	RDPU	REPU	RJPU <sup>(2)</sup>	RG4	RG3	RG2	RG1	RG0	000x xxxxx	48, 119
PORTF	RF7	RF6	RF5	RF4	RF3	RF2	RF1	—	xxxx xxx-	48, 117
PORTE	RE7	RE6	RE5	RE4	RE3	—	RE1	RE0	xxxx x-xx	48, 114
PORTD	RD7	RD6	RD5	RD4	RD3	RD2	RD1	RD0	xxxx xxxxx	48, 112
PORTC	RC7	RC6	RC5	RC4	RC3	RC2	RC1	RC0	xxxx xxxxx	48, 110
PORTB	RB7	RB6	RB5	RB4	RB3	RB2	RB1	RB0	xxxx xxxxx	48, 107
PORTA	RA7 <sup>(4)</sup>	RA6 <sup>(4)</sup>	RA5	RA4	RA3	RA2	RA1	RA0	xx0x 0000	48, 104

Legend: x = unknown, u = unchanged, - = unimplemented, α = value depends on condition, r = reserved, do not modify

**Note 1:** Bit 21 of the PC is only available in Test mode and Serial Programming modes.

**2:** Alternate names and definitions for these bits when the MSSP module is operating in I<sup>2</sup>C Slave mode. See [Section 18.4.3.2 “Address Masking”](#) for details.

**3:** The PLLEN bit is only available in specific oscillator configurations; otherwise, it is disabled and reads as ‘0’. See [Section 3.4.3 “PLL Frequency Multiplier”](#) for details.

**4:** RA<7:6> and their associated latch and direction bits are configured as port pins only when the internal oscillator is selected as the default clock source (FOSC2 Configuration bit = 0); otherwise, they are disabled and these bits read as ‘0’.



**TABLE 6-2: PIC18F87J72 FAMILY REGISTER FILE SUMMARY (CONTINUED)**

File Name	Bit 7	Bit 6	Bit 5	Bit 4	Bit 3	Bit 2	Bit 1	Bit 0	Value on POR, BOR	Details on page
SPBRGH1	EUSART Baud Rate Generator High Byte								0000 0000	49, 236
BAUDCON1	ABDOVF	RCMT	RXDTP	TXCKP	BRG16	—	WUE	ABDEN	0100 0-00	49, 234
LCDDATA22	—	—	—	—	—	—	—	S32C3	xxxx xxxx	49, 164
LCDDATA21	S31C3	S30C3	S29C3	S28C3	S27C3	S26C3	S25C3	S24C3	xxxx xxxx	49, 164
LCDDATA20	S23C3	S22C3	S21C3	S20C3	S19C3	S18C3	S17C3	S16C3	xxxx xxxx	49, 164
LCDDATA19	S15C3	S14C3	S13C3	S12C3	S11C3	S10C3	S09C3	S08C3	xxxx xxxx	49, 164
LCDDATA18	S07C3	S06C3	S05C3	S04C3	S03C3	S02C3	S01C3	S00C3	xxxx xxxx	49, 164
LCDDATA16	—	—	—	—	—	—	—	S32C2	xxxx xxxx	49, 164
LCDDATA15	S31C2	S30C2	S29C2	S28C2	S27C2	S26C2	S25C2	S24C2	xxxx xxxx	49, 164
LCDDATA14	S23C2	S22C2	S21C2	S20C2	S19C2	S18C2	S17C2	S16C2	xxxx xxxx	49, 164
LCDDATA13	S15C2	S14C2	S13C2	S12C2	S11C2	S10C2	S09C2	S08C2	xxxx xxxx	49, 164
LCDDATA12	S07C2	S06C2	S05C2	S04C2	S03C2	S02C2	S01C2	S00C2	xxxx xxxx	49, 164
LCDDATA10	—	—	—	—	—	—	—	S32C1	xxxx xxxx	49, 164
LCDDATA9	S31C1	S30C1	S29C1	S28C1	S27C1	S26C1	S25C1	S24C1	xxxx xxxx	49, 164
LCDDATA8	S23C1	S22C1	S21C1	S20C1	S19C1	S18C1	S17C1	S16C1	xxxx xxxx	49, 164
LCDDATA7	S15C1	S14C1	S13C1	S12C1	S11C1	S10C1	S09C1	S08C1	xxxx xxxx	49, 164
LCDDATA6	S07C1	S06C1	S05C1	S04C1	S03C1	S02C1	S01C1	S00C1	xxxx xxxx	49, 164
CCPR1H	Capture/Compare/PWM Register 1 High Byte								xxxx xxxx	49, 152
CCPR1L	Capture/Compare/PWM Register 1 Low Byte								xxxx xxxx	49, 152
CCP1CON	—	—	DC1B1	DC1B0	CCP1M3	CCP1M2	CCP1M1	CCP1M0	--00 0000	49, 151
CCPR2H	Capture/Compare/PWM Register 2 High Byte								xxxx xxxx	49, 152
CCPR2L	Capture/Compare/PWM Register 2 Low Byte								xxxx xxxx	49, 152
CCP2CON	—	—	DC2B1	DC2B0	CCP2M3	CCP2M2	CCP2M1	CCP2M0	--00 0000	49, 151
SPBRG2	AUSART Baud Rate Generator Register								0000 0000	50, 255
RCREG2	AUSART Receive Register								0000 0000	50, 260
TXREG2	AUSART Transmit Register								0000 0000	50, 258
TXSTA2	CSRC	TX9	TXEN	SYNC	—	BRGH	TRMT	TX9D	0000 -010	50, 253
RCSTA2	SPEN	RX9	SREN	CREN	ADDEN	FERR	OERR	RX9D	0000 000x	50, 254
RTCCFG	RTCEN	—	RTCWREN	RTCSYNC	HALFSEC	RTCOE	RTCPTR1	RTCPTRO	0-00 0000	50, 136
RTCCAL	CAL7	CAL6	CAL5	CAL4	CAL3	CAL2	CAL1	CAL0	0000 0000	50, 137
RTCVALH	RTCC Value High Register Window based on RTCPTR<1:0>								xxxx xxxx	50, 139
RTCVALL	RTCC Value Low Register Window based on RTCPTR<1:0>								xxxx xxxx	50, 139
ALRMCFG	ALRMEN	CHIME	AMASK3	AMASK2	AMASK1	AMASK0	ALRMPTR1	ALRMPTR0	0000 0000	50, 138
ALRMRPT	ARPT7	ARPT6	ARPT5	ARPT4	ARPT3	ARPT2	ARPT1	ARPT0	0000 0000	50, 139
ALRMVALH	Alarm Value High Register Window based on ALRMPTR<1:0>								xxxx xxxx	50, 142
ALRMVALL	Alarm Value Low Register Window based on ALRMPTR<1:0>								xxxx xxxx	50, 142
CTMUCONH	CTMUEN	—	CTMUSIDL	TGEN	EDGEN	EDGSEQEN	IDISSEN	CTTRIG	0-00 0000	50, 305
CTMUCONL	EDG2POL	EDG2SEL1	EDG2SEL0	EDG1POL	EDG1SEL1	EDG1SEL0	EDG2STAT	EDG1STAT	0000 0000	50, 306
CTMUICON	ITRIM5	ITRIM4	ITRIM3	ITRIM2	ITRIM1	ITRIM0	IRNG1	IRNG0	0000 0000	50, 307
PADCFG1	—	—	—	—	—	RTSECSEL1	RTSECSEL0	—	---- -00-	50, 137

Legend: x = unknown, u = unchanged, - = unimplemented, q = value depends on condition, r = reserved, do not modify

**Note 1:** Bit 21 of the PC is only available in Test mode and Serial Programming modes.

**2:** Alternate names and definitions for these bits when the MSSP module is operating in I<sup>2</sup>C Slave mode. See [Section 18.4.3.2 "Address Masking"](#) for details.

**3:** The PLEN bit is only available in specific oscillator configurations; otherwise, it is disabled and reads as '0'. See [Section 3.4.3 "PLL Frequency Multiplier"](#) for details.

**4:** RA<7:6> and their associated latch and direction bits are configured as port pins only when the internal oscillator is selected as the default clock source (FOSC2 Configuration bit = 0); otherwise, they are disabled and these bits read as '0'.

# PIC18F87J72

## 6.3.5 STATUS REGISTER

The STATUS register, shown in [Register 6-2](#), contains the arithmetic status of the ALU. The STATUS register can be the operand for any instruction, as with any other register. If the STATUS register is the destination for an instruction that affects the Z, DC, C, OV or N bits, then the write to these five bits is disabled.

These bits are set or cleared according to the device logic. Therefore, the result of an instruction with the STATUS register as destination may be different than intended. For example, `CLRF STATUS` will set the Z bit but leave the other bits unchanged. The STATUS register then reads back as '000u u1uu'. It is recom-

mended, therefore, that only `BCF`, `BSF`, `SWAPF`, `MOVFF` and `MOVWF` instructions are used to alter the STATUS register because these instructions do not affect the Z, C, DC, OV or N bits in the STATUS register.

For other instructions not affecting any Status bits, see the instruction set summaries in [Table 27-2](#) and [Table 27-3](#).

**Note:** The C and DC bits operate as a borrow and digit borrow bit respectively, in subtraction.

### REGISTER 6-2: STATUS REGISTER

U-0	U-0	U-0	R/W-x	R/W-x	R/W-x	R/W-x	R/W-x
—	—	—	N	OV	Z	DC <sup>(1)</sup>	C <sup>(2)</sup>
bit 7							bit 0

**Legend:**

R = Readable bit	W = Writable bit	U = Unimplemented bit, read as '0'
-n = Value at POR	'1' = Bit is set	'0' = Bit is cleared
		x = Bit is unknown

bit 7-5 **Unimplemented:** Read as '0'

bit 4 **N:** Negative bit

This bit is used for signed arithmetic (2's complement). It indicates whether the result was negative (ALU MSB = 1).

1 = Result was negative  
0 = Result was positive

bit 3 **OV:** Overflow bit

This bit is used for signed arithmetic (2's complement). It indicates an overflow of the 7-bit magnitude which causes the sign bit (bit 7) to change state.

1 = Overflow occurred for signed arithmetic (in this arithmetic operation)  
0 = No overflow occurred

bit 2 **Z:** Zero bit

1 = The result of an arithmetic or logic operation is zero  
0 = The result of an arithmetic or logic operation is not zero

bit 1 **DC:** Digit Carry/Borrow bit<sup>(1)</sup>

For `ADDWF`, `ADDLW`, `SUBLW` and `SUBWF` instructions:

1 = A carry-out from the 4th low-order bit of the result occurred  
0 = No carry-out from the 4th low-order bit of the result

bit 0 **C:** Carry/Borrow bit<sup>(2)</sup>

For `ADDWF`, `ADDLW`, `SUBLW` and `SUBWF` instructions:

1 = A carry-out from the Most Significant bit of the result occurred  
0 = No carry-out from the Most Significant bit of the result occurred

- Note 1:** For borrow, the polarity is reversed. A subtraction is executed by adding the 2's complement of the second operand. For rotate (`RRF`, `RLF`) instructions, this bit is loaded with either bit 4 or bit 3 of the source register.
- Note 2:** For borrow, the polarity is reversed. A subtraction is executed by adding the 2's complement of the second operand. For rotate (`RRF`, `RLF`) instructions, this bit is loaded with either the high or low-order bit of the source register.

## 6.3 Data Addressing Modes

**Note:** The execution of some instructions in the core PIC18 instruction set are changed when the PIC18 extended instruction set is enabled. See [Section 6.5 “Data Memory and the Extended Instruction Set”](#) for more information.

While the program memory can be addressed in only one way – through the program counter – information in the data memory space can be addressed in several ways. For most instructions, the addressing mode is fixed. Other instructions may use up to three modes, depending on which operands are used and whether or not the extended instruction set is enabled.

The addressing modes are:

- Inherent
- Literal
- Direct
- Indirect

An additional addressing mode, Indexed Literal Offset, is available when the extended instruction set is enabled (XINST Configuration bit = 1). Its operation is discussed in greater detail in [Section 6.5.1 “Indexed Addressing with Literal Offset”](#).

### 6.3.1 INHERENT AND LITERAL ADDRESSING

Many PIC18 control instructions do not need any argument at all; they either perform an operation that globally affects the device, or they operate implicitly on one register. This addressing mode is known as Inherent Addressing. Examples include SLEEP, RESET and DAW.

Other instructions work in a similar way, but require an additional explicit argument in the opcode. This is known as Literal Addressing mode, because they require some literal value as an argument. Examples include ADDLW and MOVLW, which respectively, add or move a literal value to the W register. Other examples include CALL and GOTO, which include a 20-bit program memory address.

### 6.3.2 DIRECT ADDRESSING

Direct Addressing specifies all or part of the source and/or destination address of the operation within the opcode itself. The options are specified by the arguments accompanying the instruction.

In the core PIC18 instruction set, bit-oriented and byte-oriented instructions use some version of Direct Addressing by default. All of these instructions include some 8-bit literal address as their Least Significant Byte. This address specifies either a register address in one of the banks of data RAM ([Section 6.3.3 “General Purpose Register File”](#)) or a location in the Access Bank ([Section 6.3.2 “Access Bank”](#)) as the data source for the instruction.

The Access RAM bit, ‘a’, determines how the address is interpreted. When ‘a’ is ‘1’, the contents of the BSR ([Section 6.3.1 “Bank Select Register”](#)) are used with the address to determine the complete 12-bit address of the register. When ‘a’ is ‘0’, the address is interpreted as being a register in the Access Bank. Addressing that uses the Access RAM is sometimes also known as Direct Forced Addressing mode.

A few instructions, such as MOVFF, include the entire 12-bit address (either source or destination) in their opcodes. In these cases, the BSR is ignored entirely.

The destination of the operation’s results is determined by the destination bit, ‘d’. When ‘d’ is ‘1’, the results are stored back in the source register, overwriting its original contents. When ‘d’ is ‘0’, the results are stored in the W register. Instructions without the ‘d’ argument have a destination that is implicit in the instruction; their destination is either the target register being operated on or the W register.

### 6.3.3 INDIRECT ADDRESSING

Indirect Addressing allows the user to access a location in data memory without giving a fixed address in the instruction. This is done by using File Select Registers (FSRs) as pointers to the locations to be read or written to. Since the FSRs are themselves located in RAM as Special Function Registers, they can also be directly manipulated under program control. This makes FSRs very useful in implementing data structures such as tables and arrays in data memory.

The registers for Indirect Addressing are also implemented with Indirect File Operands (INDFs) that permit automatic manipulation of the pointer value with auto-incrementing, auto-decrementing or offsetting with another value. This allows for efficient code using loops, such as the example of clearing an entire RAM bank in [Example 6-5](#). It also enables users to perform Indexed Addressing and other Stack Pointer operations for program memory in data memory.

#### EXAMPLE 6-5: HOW TO CLEAR RAM (BANK 1) USING INDIRECT ADDRESSING

```

LFSR    FSR0, 100h ;
NEXT    CLRF    POSTINC0 ; Clear INDF
                                ; register then
                                ; inc pointer
        BTFSS   FSR0H, 1 ; All done with
                                ; Bank1?
        BRA     NEXT     ; NO, clear next
CONTINUE                                ; YES, continue
    
```

# PIC18F87J72

## 6.3.3.1 FSR Registers and the INDF Operand

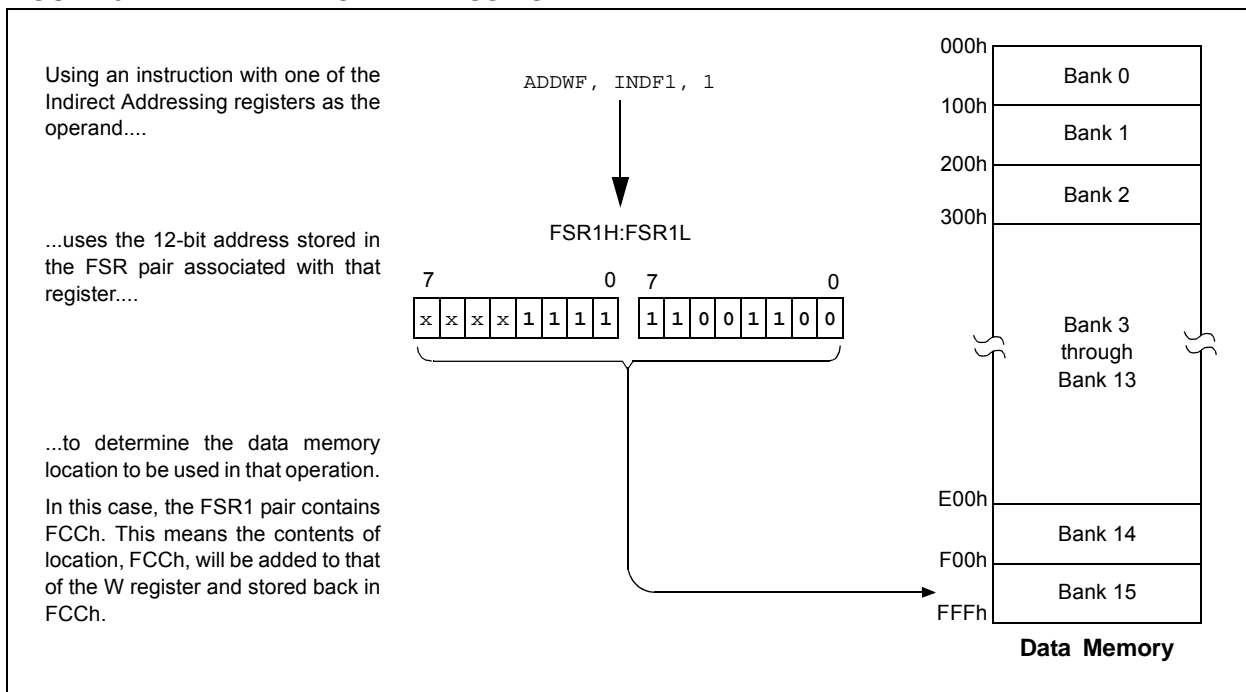
At the core of Indirect Addressing are three sets of registers: FSR0, FSR1 and FSR2. Each represents a pair of 8-bit registers, FSRnH and FSRnL. The four upper bits of the FSRnH register are not used, so each FSR pair holds a 12-bit value. This represents a value that can address the entire range of the data memory in a linear fashion. The FSR register pairs, then, serve as pointers to data memory locations.

Indirect Addressing is accomplished with a set of Indirect File Operands, INDF0 through INDF2. These can be thought of as “virtual” registers: they are mapped in

the SFR space but are not physically implemented. Reading or writing to a particular INDF register actually accesses its corresponding FSR register pair. A read from INDF1, for example, reads the data at the address indicated by FSR1H:FSR1L. Instructions that use the INDF registers as operands actually use the contents of their corresponding FSR as a pointer to the instruction's target. The INDF operand is just a convenient way of using the pointer.

Because Indirect Addressing uses a full 12-bit address, data RAM banking is not necessary. Thus, the current contents of the BSR and the Access RAM bit have no effect on determining the target address.

**FIGURE 6-1: INDIRECT ADDRESSING**



## 6.3.3.2 FSR Registers and POSTINC, POSTDEC, PREINC and PLUSW

In addition to the INDF operand, each FSR register pair also has four additional indirect operands. Like INDF, these are “virtual” registers that cannot be indirectly read or written to. Accessing these registers actually accesses the associated FSR register pair, but also performs a specific action on its stored value. They are:

- **POSTDEC**: accesses the FSR value, then automatically decrements it by ‘1’ afterwards
- **POSTINC**: accesses the FSR value, then automatically increments it by ‘1’ afterwards
- **PREINC**: increments the FSR value by ‘1’, then uses it in the operation
- **PLUSW**: adds the signed value of the W register (range of -127 to 128) to that of the FSR and uses the new value in the operation

In this context, accessing an INDF register uses the value in the FSR registers without changing them. Similarly, accessing a PLUSW register gives the FSR value offset by the value in the W register; neither value is actually changed in the operation. Accessing the other virtual registers changes the value of the FSR registers.

Operations on the FSRs with POSTDEC, POSTINC and PREINC affect the entire register pair; that is, roll-overs of the FSRnL register from FFh to 00h carry over to the FSRnH register. On the other hand, results of these operations do not change the value of any flags in the STATUS register (e.g., Z, N, OV, etc.).

The PLUSW register can be used to implement a form of Indexed Addressing in the data memory space. By manipulating the value in the W register, users can reach addresses that are fixed offsets from pointer addresses. In some applications, this can be used to implement some powerful program control structure, such as software stacks, inside of data memory.

## 6.3.3.3 Operations by FSRs on FSRs

Indirect Addressing operations that target other FSRs or virtual registers represent special cases. For example, using an FSR to point to one of the virtual registers will not result in successful operations. As a specific case, assume that the FSR0H:FSR0L registers contain FE7h, the address of INDF1. Attempts to read the value of the INDF1, using INDF0 as an operand, will return 00h. Attempts to write to INDF1, using INDF0 as the operand, will result in a NOP.

On the other hand, using the virtual registers to write to an FSR pair may not occur as planned. In these cases, the value will be written to the FSR pair but without any incrementing or decrementing. Thus, writing to INDF2 or POSTDEC2 will write the same value to the FSR2H:FSR2L.

Since the FSRs are physical registers mapped in the SFR space, they can be manipulated through all direct operations. Users should proceed cautiously when working on these registers, particularly if their code uses Indirect Addressing.

Similarly, operations by Indirect Addressing are generally permitted on all other SFRs. Users should exercise the appropriate caution that they do not inadvertently change settings that might affect the operation of the device.

## 6.4 Program Memory and the Extended Instruction Set

The operation of program memory is unaffected by the use of the extended instruction set.

Enabling the extended instruction set adds five additional two-word commands to the existing PIC18 instruction set: ADDFSR, CALLW, MOVSF, MOVSS and SUBFSR. These instructions are executed as described in [Section 6.2.4 “Two-Word Instructions”](#).

## 6.5 Data Memory and the Extended Instruction Set

Enabling the PIC18 extended instruction set (XINST Configuration bit = 1) significantly changes certain aspects of data memory and its addressing. Specifically, the use of the Access Bank for many of the core PIC18 instructions is different. This is due to the introduction of a new addressing mode for the data memory space. This mode also alters the behavior of Indirect Addressing using FSR2 and its associated operands.

What does not change is just as important. The size of the data memory space is unchanged, as well as its linear addressing. The SFR map remains the same. Core PIC18 instructions can still operate in both Direct and Indirect Addressing mode; inherent and literal instructions do not change at all. Indirect Addressing with FSR0 and FSR1 also remains unchanged.

### 6.5.1 INDEXED ADDRESSING WITH LITERAL OFFSET

Enabling the PIC18 extended instruction set changes the behavior of Indirect Addressing using the FSR2 register pair and its associated file operands. Under the proper conditions, instructions that use the Access Bank – that is, most bit-oriented and byte-oriented instructions – can invoke a form of Indexed Addressing using an offset specified in the instruction. This special addressing mode is known as Indexed Addressing with Literal Offset, or Indexed Literal Offset mode.

When using the extended instruction set, this addressing mode requires the following:

- The use of the Access Bank is forced ('a' = 0);  
and
- The file address argument is less than or equal to 5Fh.

Under these conditions, the file address of the instruction is not interpreted as the lower byte of an address (used with the BSR in Direct Addressing) or as an 8-bit address in the Access Bank. Instead, the value is interpreted as an offset value to an Address Pointer specified by FSR2. The offset and the contents of FSR2 are added to obtain the target address of the operation.

### 6.5.2 INSTRUCTIONS AFFECTED BY INDEXED LITERAL OFFSET MODE

Any of the core PIC18 instructions that can use Direct Addressing are potentially affected by the Indexed Literal Offset Addressing mode. This includes all byte-oriented and bit-oriented instructions, or almost one-half of the standard PIC18 instruction set. Instructions that only use Inherent or Literal Addressing modes are unaffected.

Additionally, byte-oriented and bit-oriented instructions are not affected if they use the Access Bank (Access RAM bit is '1') or include a file address of 60h or above. Instructions meeting these criteria will continue to execute as before. A comparison of the different possible addressing modes when the extended instruction set is enabled is shown in [Figure 6-2](#).

Those who desire to use byte-oriented or bit-oriented instructions in the Indexed Literal Offset mode should note the changes to assembler syntax for this mode. This is described in more detail in [Section 27.2.1 “Extended Instruction Syntax”](#).

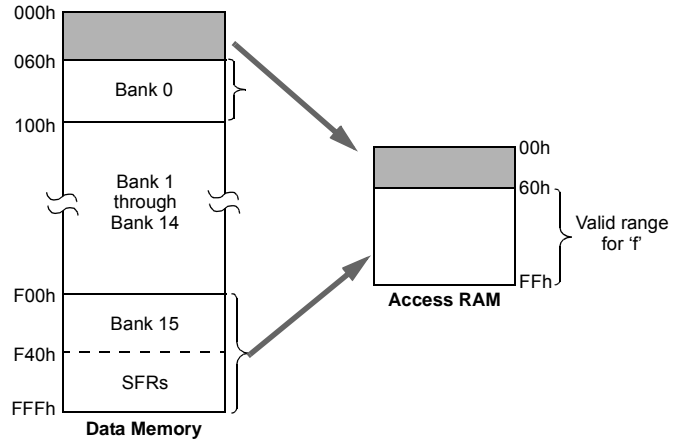
**FIGURE 6-2: COMPARING ADDRESSING OPTIONS FOR BIT-ORIENTED AND BYTE-ORIENTED INSTRUCTIONS (EXTENDED INSTRUCTION SET ENABLED)**

**EXAMPLE INSTRUCTION:** ADDWF, f, d, a (Opcode: 0010 01da ffff ffff)

**When a = 0 and f ≥ 60h:**

The instruction executes in Direct Forced mode. 'f' is interpreted as a location in the Access RAM between 060h and FFFh. This is the same as locations, F60h to FFFh (Bank 15), of data memory.

Locations below 060h are not available in this addressing mode.



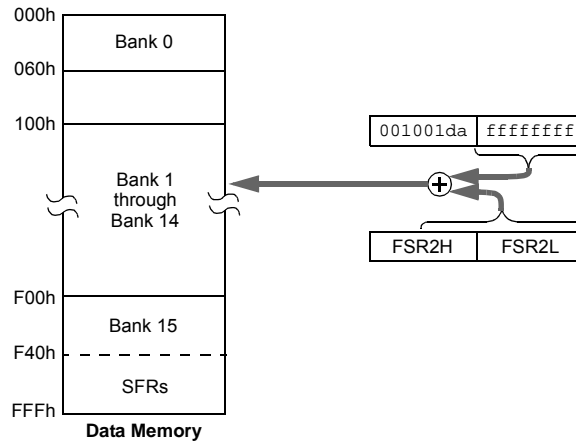
**When a = 0 and f ≤ 5Fh:**

The instruction executes in Indexed Literal Offset mode. 'f' is interpreted as an offset to the address value in FSR2. The two are added together to obtain the address of the target register for the instruction. The address can be anywhere in the data memory space.

Note that in this mode, the correct syntax is now:

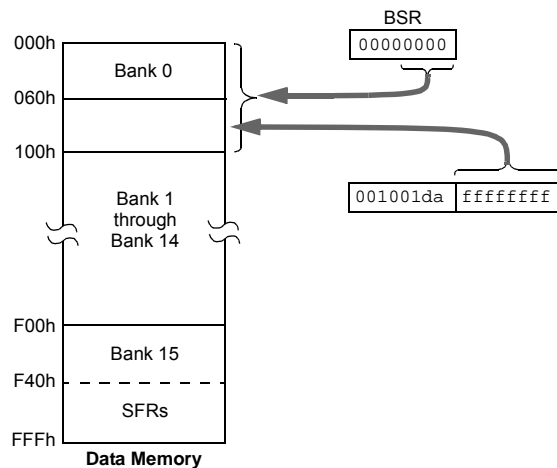
ADDWF [k], d

where 'k' is the same as 'f'.



**When a = 1 (all values of f):**

The instruction executes in Direct mode (also known as Direct Long mode). 'f' is interpreted as a location in one of the 16 banks of the data memory space. The bank is designated by the Bank Select Register (BSR). The address can be in any implemented bank in the data memory space.



# PIC18F87J72

## 6.5.3 MAPPING THE ACCESS BANK IN INDEXED LITERAL OFFSET MODE

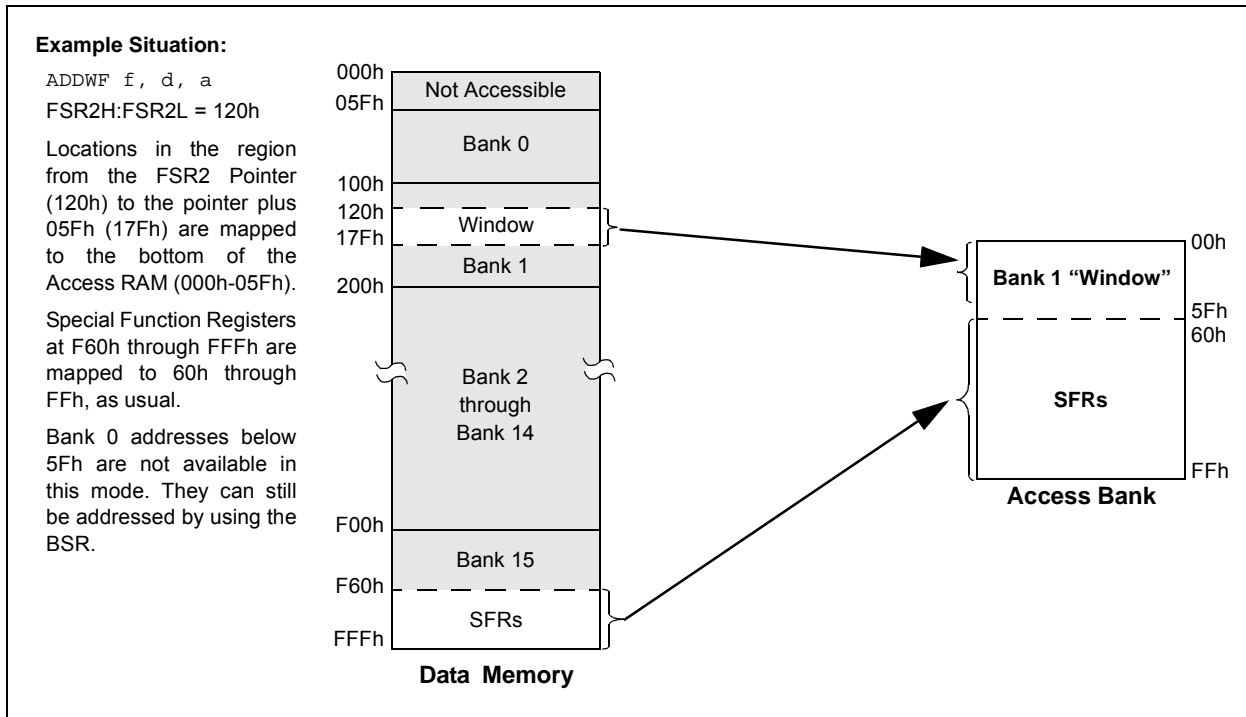
The use of Indexed Literal Offset Addressing mode effectively changes how the lower part of Access RAM (00h to 5Fh) is mapped. Rather than containing just the contents of the bottom part of Bank 0, this mode maps the contents from Bank 0 and a user-defined “window” that can be located anywhere in the data memory space. The value of FSR2 establishes the lower boundary of the addresses mapped into the window, while the upper boundary is defined by FSR2 plus 95 (5Fh). Addresses in the Access RAM above 5Fh are mapped as previously described (see [Section 6.3.2 “Access Bank”](#)). An example of Access Bank remapping in this addressing mode is shown in [Figure 6-3](#).

Remapping of the Access Bank applies *only* to operations using the Indexed Literal Offset mode. Operations that use the BSR (Access RAM bit is ‘1’) will continue to use Direct Addressing as before. Any Indirect or Indexed Addressing operation that explicitly uses any of the indirect file operands (including FSR2) will continue to operate as standard Indirect Addressing. Any instruction that uses the Access Bank, but includes a register address of greater than 05Fh, will use Direct Addressing and the normal Access Bank map.

## 6.5.4 BSR IN INDEXED LITERAL OFFSET MODE

Although the Access Bank is remapped when the extended instruction set is enabled, the operation of the BSR remains unchanged. Direct Addressing, using the BSR to select the data memory bank, operates in the same manner as previously described.

**FIGURE 6-3: REMAPPING THE ACCESS BANK WITH INDEXED LITERAL OFFSET ADDRESSING**





## 7.0 FLASH PROGRAM MEMORY

The Flash program memory is readable, writable and erasable during normal operation over the entire VDD range.

A read from program memory is executed on one byte at a time. A write to program memory is executed on blocks of 64 bytes at a time or two bytes at a time. Program memory is erased in blocks of 1,024 bytes at a time. A bulk erase operation may not be issued from user code.

Writing or erasing program memory will cease instruction fetches until the operation is complete. The program memory cannot be accessed during the write or erase, therefore, code cannot execute. An internal programming timer terminates program memory writes and erases.

A value written to program memory does not need to be a valid instruction. Executing a program memory location that forms an invalid instruction results in a NOP.

## 7.1 Table Reads and Table Writes

In order to read and write program memory, there are two operations that allow the processor to move bytes between the program memory space and the data RAM:

- Table Read (TBLRD)
- Table Write (TBLWT)

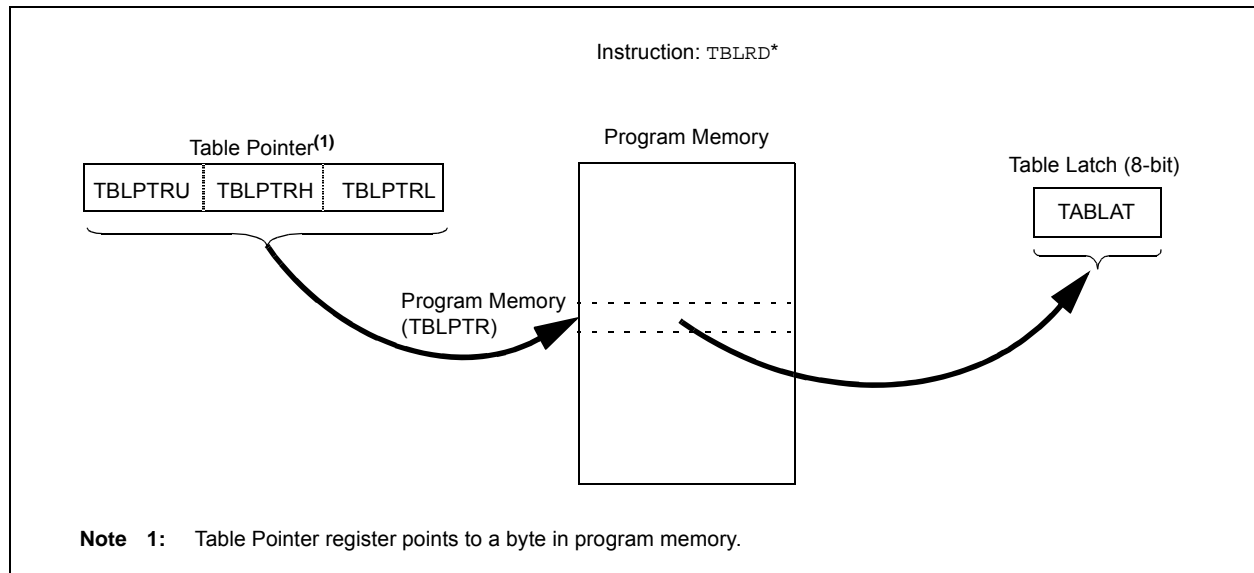
The program memory space is 16 bits wide, while the data RAM space is eight bits wide. Table reads and table writes move data between these two memory spaces through an 8-bit register (TABLAT).

Table read operations retrieve data from program memory and place it into the data RAM space. [Figure 7-1](#) shows the operation of a table read with program memory and data RAM.

Table write operations store data from the data memory space into holding registers in program memory. The procedure to write the contents of the holding registers into program memory is detailed in [Section 7.5 “Writing to Flash Program Memory”](#). [Figure 7-2](#) shows the operation of a table write with program memory and data RAM.

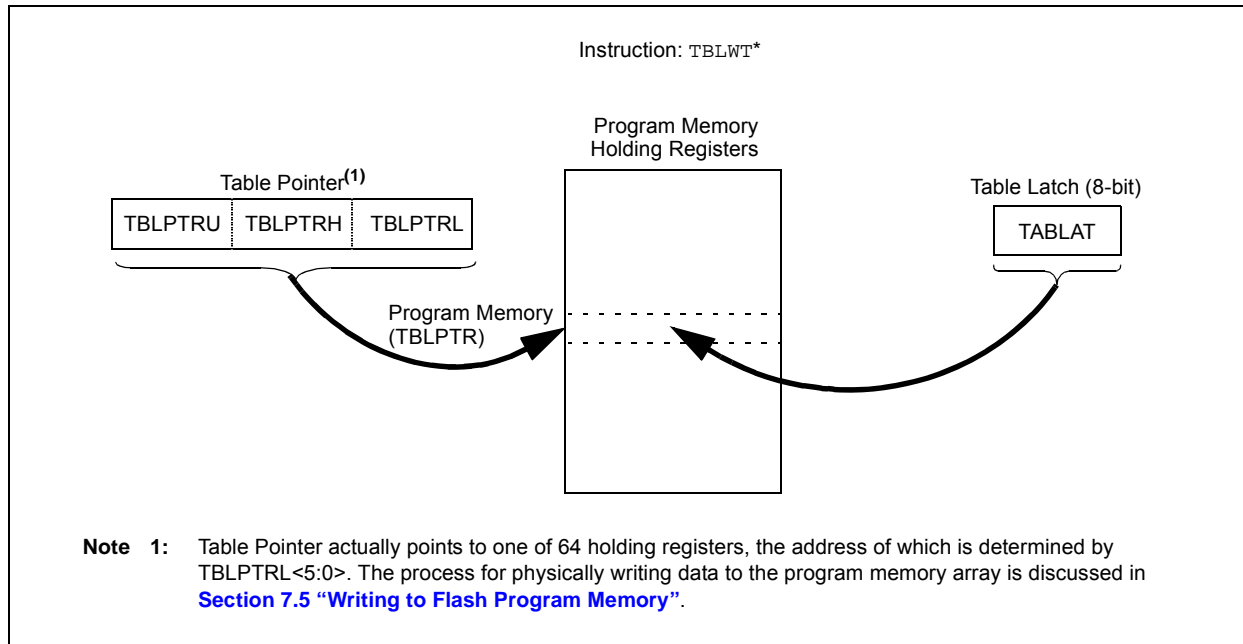
Table operations work with byte entities. A table block containing data, rather than program instructions, is not required to be word-aligned. Therefore, a table block can start and end at any byte address. If a table write is being used to write executable code into program memory, program instructions will need to be word-aligned.

**FIGURE 7-1: TABLE READ OPERATION**



# PIC18F87J72

FIGURE 7-2: TABLE WRITE OPERATION



## 7.2 Control Registers

Several control registers are used in conjunction with the TBLRD and TBLWT instructions. These include the:

- EECON1 register
- EECON2 register
- TABLAT register
- TBLPTR registers

### 7.2.1 EECON1 AND EECON2 REGISTERS

The EECON1 register ([Register 7-1](#)) is the control register for memory accesses. The EECON2 register is not a physical register; it is used exclusively in the memory write and erase sequences. Reading EECON2 will read all '0's.

The WPROG bit, when set, allows the user to program a single word (two bytes) upon the execution of the WR command. If this bit is cleared, the WR command programs a block of 64 bytes.

The FREE bit, when set, will allow a program memory erase operation. When FREE is set, the erase operation is initiated on the next WR command. When FREE is clear, only writes are enabled.

The WREN bit, when set, will allow a write operation. On power-up, the WREN bit is clear. The WRERR bit is set in hardware when the WR bit is set and cleared when the internal programming timer expires and the write operation is complete.

**Note:** During normal operation, the WRERR is read as '1'. This can indicate that a write operation was prematurely terminated by a Reset, or a write operation was attempted improperly.

The WR control bit initiates write operations. The bit cannot be cleared, only set, in software. It is cleared in hardware at the completion of the write operation.

## REGISTER 7-1: EECON1: EEPROM CONTROL REGISTER 1

U-0	U-0	R/W-0	R/W-0	R/W-x	R/W-0	R/S-0	U-0
—	—	WPROG	FREE	WRERR <sup>(1)</sup>	WREN	WR	—
bit 7							bit 0

Legend:	S = Settable bit (cannot be cleared in software)
R = Readable bit	W = Writable bit
-n = Value at POR	'1' = Bit is set
	'0' = Bit is cleared
	x = Bit is unknown

bit 7-6 **Unimplemented:** Read as '0'

bit 5 **WPROG:** One Word-Wide Program bit  
 1 = Program 2 bytes on the next WR command  
 0 = Program 64 bytes on the next WR command

bit 4 **FREE:** Flash Erase Enable bit  
 1 = Performs an erase operation on the next WR command (cleared by completion of erase operation)  
 0 = Perform write only

bit 3 **WRERR:** Flash Program Error Flag bit<sup>(1)</sup>  
 1 = A write operation is prematurely terminated (any Reset during self-timed programming in normal operation or an improper write attempt)  
 0 = The write operation completed

bit 2 **WREN:** Flash Program Write Enable bit  
 1 = Allows write cycles to Flash program memory  
 0 = Inhibits write cycles to Flash program memory

bit 1 **WR:** Write Control bit  
 1 = Initiates a program memory erase cycle or write cycle  
 (The operation is self-timed and the bit is cleared by hardware once write is complete. The WR bit can only be set (not cleared) in software.)  
 0 = Write cycle is complete

bit 0 **Unimplemented:** Read as '0'

**Note 1:** When a WRERR occurs, the EEPGD and CFGS bits are not cleared. This allows tracing of the error condition.

# PIC18F87J72

## 7.2.2 TABLE LATCH REGISTER (TABLAT)

The Table Latch (TABLAT) is an 8-bit register mapped into the SFR space. The Table Latch register is used to hold 8-bit data during data transfers between program memory and data RAM.

## 7.2.3 TABLE POINTER REGISTER (TBLPTR)

The Table Pointer (TBLPTR) register addresses a byte within the program memory. The TBLPTR is comprised of three SFR registers: Table Pointer Upper Byte, Table Pointer High Byte and Table Pointer Low Byte (TBLPTRU:TBLPTRH:TBLPTRL). These three registers join to form a 22-bit wide pointer. The low-order 21 bits allow the device to address up to 2 Mbytes of program memory space. The 22nd bit allows access to the device ID, the user ID and the Configuration bits.

The Table Pointer register, TBLPTR, is used by the TBLRD and TBLWT instructions. These instructions can update the TBLPTR in one of four ways based on the table operation. These operations are shown in Table 7-1. These operations on the TBLPTR only affect the low-order 21 bits.

## 7.2.4 TABLE POINTER BOUNDARIES

TBLPTR is used in reads, writes and erases of the Flash program memory.

When a TBLRD is executed, all 22 bits of the TBLPTR determine which byte is read from program memory into TABLAT.

When a TBLWT is executed, the seven LSbs of the Table Pointer register (TBLPTR<6:0>) determine which of the 64 program memory holding registers is written to. When the timed write to program memory begins (via the WR bit), the 12 MSBs of the TBLPTR (TBLPTR<21:10>) determine which program memory block of 1,024 bytes is written to. For more detail, see Section 7.5 "Writing to Flash Program Memory".

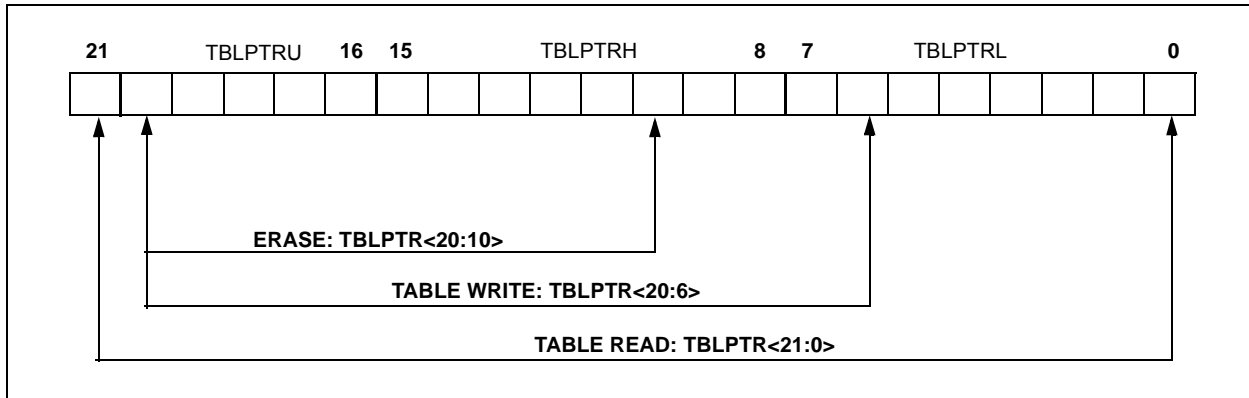
When an erase of program memory is executed, the 12 MSBs of the Table Pointer register point to the 1,024-byte block that will be erased. The Least Significant bits are ignored.

Figure 7-3 describes the relevant boundaries of TBLPTR based on Flash program memory operations.

**TABLE 7-1: TABLE POINTER OPERATIONS WITH TBLRD AND TBLWT INSTRUCTIONS**

Example	Operation on Table Pointer
TBLRD* TBLWT*	TBLPTR is not modified
TBLRD*+ TBLWT*+	TBLPTR is incremented after the read/write
TBLRD*- TBLWT*-	TBLPTR is decremented after the read/write
TBLRD+* TBLWT+*	TBLPTR is incremented before the read/write

**FIGURE 7-3: TABLE POINTER BOUNDARIES BASED ON OPERATION**



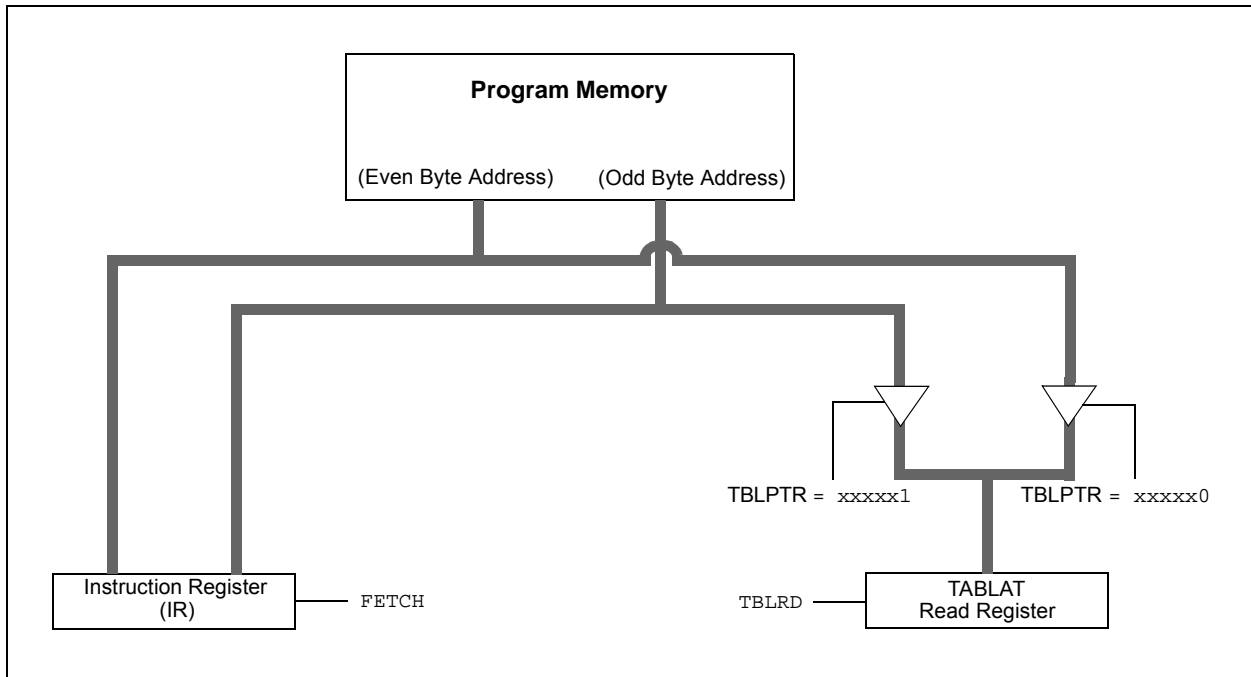
## 7.3 Reading the Flash Program Memory

The `TBLRD` instruction is used to retrieve data from program memory and places it into data RAM. Table reads from program memory are performed one byte at a time.

`TBLPTR` points to a byte address in program space. Executing `TBLRD` places the byte pointed to into `TABLAT`. In addition, `TBLPTR` can be modified automatically for the next table read operation.

The internal program memory is typically organized by words. The Least Significant bit of the address selects between the high and low bytes of the word. [Figure 7-4](#) shows the interface between the internal program memory and the `TABLAT`.

**FIGURE 7-4: READS FROM FLASH PROGRAM MEMORY**



**EXAMPLE 7-1: READING A FLASH PROGRAM MEMORY WORD**

```

MOVLWCODE_ADDR_UPPER      ; Load TBLPTR with the base
MOVWFTBLPTRU              ; address of the word
MOVLWCODE_ADDR_HIGH
MOVWFTBLPTRH
MOVLWCODE_ADDR_LOW
MOVWFTBLPTRL
READ_WORD
TBLRD*+                   ; read into TABLAT and increment
MOVFBTABLAT, W            ; get data
MOVWWORD_EVEN
TBLRD*+                   ; read into TABLAT and increment
MOVFBTABLAT, W            ; get data
MOVWWORD_ODD
    
```

# PIC18F87J72

## 7.4 Erasing Flash Program Memory

The minimum erase block is 512 words or 1,024 bytes. Only through the use of an external programmer, or through ICSP control, can larger blocks of program memory be bulk erased. Word erase in the Flash array is not supported.

When initiating an erase sequence from the microcontroller itself, a block of 1,024 bytes of program memory is erased. The Most Significant 12 bits of the TBLPTR<21:10> point to the block being erased. TBLPTR<9:0> are ignored.

The EECON1 register commands the erase operation. The WREN bit must be set to enable write operations. The FREE bit is set to select an erase operation. For protection, the write initiate sequence for EECON2 must be used.

A long write is necessary for erasing the internal Flash. Instruction execution is halted while in a long write cycle. The long write will be terminated by the internal programming timer.

### 7.4.1 FLASH PROGRAM MEMORY ERASE SEQUENCE

The sequence of events for erasing a block of internal program memory location is:

1. Load Table Pointer register with the address being erased.
2. Set the WREN and FREE bits (EECON1<2,4>) to enable the erase operation.
3. Disable interrupts.
4. Write 55h to EECON2.
5. Write 0AAh to EECON2.
6. Set the WR bit. This will begin the erase cycle.
7. The CPU will stall for duration of the erase for TIE (see parameter [D133B](#)).
8. Re-enable interrupts.

#### EXAMPLE 7-2: ERASING FLASH PROGRAM MEMORY

	MOVLW	CODE_ADDR_UPPER	; load TBLPTR with the base
	MOVWF	TBLPTRU	; address of the memory block
	MOVLW	CODE_ADDR_HIGH	
	MOVWF	TBLPTRH	
	MOVLW	CODE_ADDR_LOW	
	MOVWF	TBLPTRL	
ERASE			
	BSF	EECON1, WREN	
	BSF	EECON1, FREE	; enable Erase operation
	BCF	INTCON, GIE	; disable interrupts
<b>Required Sequence</b>	MOVLW	55h	
	MOVWF	EECON2	; write 55h
	MOVLW	0AAh	
	MOVWF	EECON2	; write 0AAh
	BSF	EECON1, WR	; start erase (CPU stall)
	BSF	INTCON, GIE	; re-enable interrupts

## 7.5 Writing to Flash Program Memory

The programming block is 32 words or 64 bytes. Programming one word or two bytes at a time is also supported.

Table writes are used internally to load the holding registers needed to program the Flash memory. There are 64 holding registers used by the table writes for programming.

Since the Table Latch (TABLAT) is only a single byte, the TBLWT instruction may need to be executed 64 times for each programming operation (if WPROG = 0). All of the table write operations will essentially be short writes because only the holding registers are written. At the end of updating the 64 holding registers, the EECON1 register must be written to in order to start the programming operation with a long write.

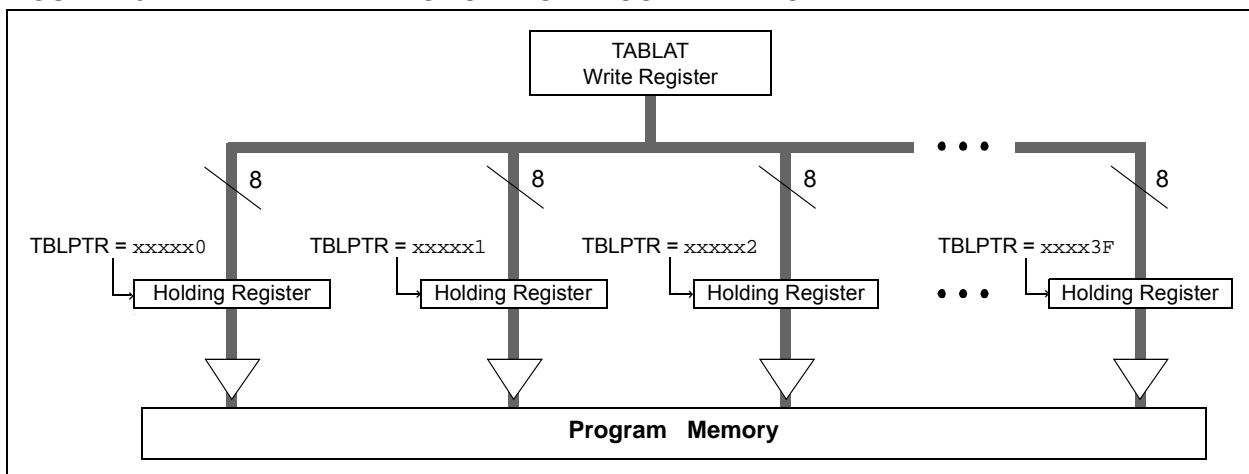
The long write is necessary for programming the internal Flash. Instruction execution is halted while in a long write cycle. The long write will be terminated by the internal programming timer.

The on-chip timer controls the write time. The write/erase voltages are generated by an on-chip charge pump, rated to operate over the voltage range of the device.

**Note 1:** Unlike previous PIC18 Flash devices, members of the PIC18F87J72 family do not reset the holding registers after a write occurs. The holding registers must be cleared or overwritten before a programming sequence.

**2:** To maintain the endurance of the program memory cells, each Flash byte should not be programmed more than one time between erase operations. Before attempting to modify the contents of the target cell a second time, an erase of the target, or a bulk erase of the entire memory, must be performed.

**FIGURE 7-5: TABLE WRITES TO FLASH PROGRAM MEMORY**



### 7.5.1 FLASH PROGRAM MEMORY WRITE SEQUENCE

The sequence of events for programming an internal program memory location should be:

1. Read 1,024 bytes into RAM.
2. Update data values in RAM as necessary.
3. Load Table Pointer register with the address being erased.
4. Execute the erase procedure.
5. Load Table Pointer register with the address of the first byte being written, minus 1.
6. Write the 64 bytes into the holding registers with auto-increment.
7. Set the WREN bit (EECON1<2>) to enable byte writes.
8. Disable interrupts.
9. Write 55h to EECON2.
10. Write 0AAh to EECON2.
11. Set the WR bit. This will begin the write cycle.
12. The CPU will stall for the duration of the write for  $T_{iw}$  (parameter [D133A](#)).
13. Re-enable interrupts.
14. Repeat steps 6 through 13 until all 1,024 bytes are written to program memory.
15. Verify the memory (table read).

An example of the required code is shown in [Example 7-3](#) on the following page.

**Note:** Before setting the WR bit, the Table Pointer address needs to be within the intended address range of the 64 bytes in the holding register.

# PIC18F87J72

## EXAMPLE 7-3: WRITING TO FLASH PROGRAM MEMORY

```
MOV LW CODE_ADDR_UPPER ; Load TBLPTR with the base address
MOV WF TBLPTRU ; of the memory block, minus 1
MOV LW CODE_ADDR_HIGH
MOV WF TBLPTRH
MOV LW CODE_ADDR_LOW
MOV WF TBLPTRL

ERASE_BLOCK
BSF EECON1, WREN ; enable write to memory
BSF EECON1, FREE ; enable Erase operation
BCF INTCON, GIE ; disable interrupts
MOV LW 55h
MOV WF EECON2 ; write 55h
MOV LW 0AAh
MOV WF EECON2 ; write 0AAh
BSF EECON1, WR ; start erase (CPU stall)
BSF INTCON, GIE ; re-enable interrupts
MOV LW D'16'
MOV WF WRITE_COUNTER ; Need to write 16 blocks of 64 to write
; one erase block of 1024

RESTART_BUFFER
MOV LW D'64'
MOV WF COUNTER
MOV LW BUFFER_ADDR_HIGH ; point to buffer
MOV WF FSR0H
MOV LW BUFFER_ADDR_LOW
MOV WF FSR0L

FILL_BUFFER
... ; read the new data from I2C, SPI,
; PSP, USART, etc.

WRITE_BUFFER
MOV LW D'64 ; number of bytes in holding register
MOV WF COUNTER

WRITE_BYTE_TO_HREGS
MOV FF POSTINC0, WREG ; get low byte of buffer data
MOV WF TABLAT ; present data to table latch
TBLWT+* ; write data, perform a short write
; to internal TBLWT holding register.
DECFSZ COUNTER ; loop until buffers are full
BRA WRITE_BYTE_TO_HREGS

PROGRAM_MEMORY
BSF EECON1, WREN ; enable write to memory
BCF INTCON, GIE ; disable interrupts
Required MOV LW 55h
Sequence MOV WF EECON2 ; write 55h
MOV LW 0AAh
MOV WF EECON2 ; write 0AAh
BSF EECON1, WR ; start program (CPU stall)
BSF INTCON, GIE ; re-enable interrupts
BCF EECON1, WREN ; disable write to memory

DECFSZ WRITE_COUNTER ; done with one write cycle
BRA RESTART_BUFFER ; if not done replacing the erase block
```



## 7.5.2 FLASH PROGRAM MEMORY WRITE SEQUENCE (WORD PROGRAMMING).

The PIC18F87J72 family of devices has a feature that allows programming a single word (two bytes). This feature is enabled when the WPROG bit is set. If the memory location is already erased, the following sequence is required to enable this feature:

1. Load the Table Pointer register with the address of the data to be written
2. Write the 2 bytes into the holding registers and perform a table write
3. Set WPROG to enable single-word write.
4. Set WREN to enable write to memory.
5. Disable interrupts.
6. Write 55h to EECON2.
7. Write 0AAh to EECON2.
8. Set the WR bit. This will begin the write cycle.
9. The CPU will stall for duration of the write for Tw (see parameter D133A).
10. Re-enable interrupts.

### EXAMPLE 7-4: SINGLE-WORD WRITE TO FLASH PROGRAM MEMORY

	MOVLW	CODE_ADDR_UPPER	; Load TBLPTR with the base address
	MOVWF	TBLPTRU	
	MOVLW	CODE_ADDR_HIGH	
	MOVWF	TBLPTRH	
	MOVLW	CODE_ADDR_LOW	
	MOVWF	TBLPTRL	
	MOVLW	DATA0	
	MOVWF	TABLAT	
	TBLWT*+		
	MOVLW	DATA1	
	MOVWF	TABLAT	
	TBLWT*		
PROGRAM_MEMORY	BSF	EECON1, WPROG	; enable single word write
	BSF	EECON1, WREN	; enable write to memory
	BCF	INTCON, GIE	; disable interrupts
	MOVLW	55h	
Required	MOVWF	EECON2	; write 55h
Sequence	MOVLW	0AAh	
	MOVWF	EECON2	; write 0AAh
	BSF	EECON1, WR	; start program (CPU stall)
	BSF	INTCON, GIE	; re-enable interrupts
	BCF	EECON1, WPROG	; disable single word write
	BCF	EECON1, WREN	; disable write to memory

# PIC18F87J72

## 7.5.3 WRITE VERIFY

Depending on the application, good programming practice may dictate that the value written to the memory should be verified against the original value. This should be used in applications where excessive writes can stress bits near the specification limit.

## 7.5.4 UNEXPECTED TERMINATION OF WRITE OPERATION

If a write is terminated by an unplanned event, such as loss of power or an unexpected Reset, the memory location just programmed should be verified and reprogrammed if needed. If the write operation is interrupted by a MCLR Reset or a WDT time-out Reset during normal operation, the user can check the WRERR bit and rewrite the location(s) as needed.

## 7.6 Flash Program Operation During Code Protection

See [Section 26.6 “Program Verification and Code Protection”](#) for details on code protection of Flash program memory.

**TABLE 7-2: REGISTERS ASSOCIATED WITH PROGRAM FLASH MEMORY**

Name	Bit 7	Bit 6	Bit 5	Bit 4	Bit 3	Bit 2	Bit 1	Bit 0	Reset Values on Page:
TBLPTRU	—	—	bit 21	Program Memory Table Pointer Upper Byte (TBLPTR<20:16>)					45
TBPLTRH	Program Memory Table Pointer High Byte (TBLPTR<15:8>)								45
TBLPTRL	Program Memory Table Pointer Low Byte (TBLPTR<7:0>)								45
TABLAT	Program Memory Table Latch								45
INTCON	GIE/GIEH	PEIE/GIE L	TMR0IE	INT0IE	RBIE	TMR0IF	INT0IF	RBIF	45
EECON2	EEPROM Control Register 2 (not a physical register)								47
EECON1	—	—	WPROG	FREE	WRERR	WREN	WR	—	47

Legend: — = unimplemented, read as '0'. Shaded cells are not used during Flash program memory access.

## 8.0 8 x 8 HARDWARE MULTIPLIER

### 8.1 Introduction

All PIC18 devices include an 8 x 8 hardware multiplier as part of the ALU. The multiplier performs an unsigned operation and yields a 16-bit result that is stored in the product register pair, PRODH:PRODL. The multiplier's operation does not affect any flags in the STATUS register.

Making multiplication a hardware operation allows it to be completed in a single instruction cycle. This has the advantages of higher computational throughput and reduced code size for multiplication algorithms and allows the PIC18 devices to be used in many applications previously reserved for digital signal processors. A comparison of various hardware and software multiply operations, along with the savings in memory and execution time, is shown in [Table 8-1](#).

### 8.2 Operation

[Example 8-1](#) shows the instruction sequence for an 8 x 8 unsigned multiplication. Only one instruction is required when one of the arguments is already loaded in the WREG register.

[Example 8-2](#) shows the sequence to do an 8 x 8 signed multiplication. To account for the sign bits of the arguments, each argument's Most Significant bit (MSb) is tested and the appropriate subtractions are done.

#### EXAMPLE 8-1: 8 x 8 UNSIGNED MULTIPLY ROUTINE

```
MOVWF ARG1, W      ;
MULWF ARG2          ; ARG1 * ARG2 ->
                   ; PRODH:PRODL
```

#### EXAMPLE 8-2: 8 x 8 SIGNED MULTIPLY ROUTINE

```
MOVWF ARG1, W      ;
MULWF ARG2          ; ARG1 * ARG2 ->
                   ; PRODH:PRODL

BTFSC ARG2, SB     ; Test Sign Bit
SUBWF PRODH, F     ; PRODH = PRODH
                   ; - ARG1

MOVWF ARG2, W      ;
BTFSC ARG1, SB     ; Test Sign Bit
SUBWF PRODH, F     ; PRODH = PRODH
                   ; - ARG2
```

**TABLE 8-1: PERFORMANCE COMPARISON FOR VARIOUS MULTIPLY OPERATIONS**

Routine	Multiply Method	Program Memory (Words)	Cycles (Max)	Time		
				@ 48 MHz	@ 10 MHz	@ 4 MHz
8 x 8 unsigned	Without hardware multiply	13	69	5.7 μs	27.6 μs	69 μs
	Hardware multiply	1	1	83.3 ns	400 ns	1 μs
8 x 8 signed	Without hardware multiply	33	91	7.5 μs	36.4 μs	91 μs
	Hardware multiply	6	6	500 ns	2.4 μs	6 μs
16 x 16 unsigned	Without hardware multiply	21	242	20.1 μs	96.8 μs	242 μs
	Hardware multiply	28	28	2.3 μs	11.2 μs	28 μs
16 x 16 signed	Without hardware multiply	52	254	21.6 μs	102.6 μs	254 μs
	Hardware multiply	35	40	3.3 μs	16.0 μs	40 μs

# PIC18F87J72

**Example 8-3** shows the sequence to do a 16 x 16 unsigned multiplication. **Equation 8-1** shows the algorithm that is used. The 32-bit result is stored in four registers (RES3:RES0).

## EQUATION 8-1: 16 x 16 UNSIGNED MULTIPLICATION ALGORITHM

$$\begin{aligned} \text{RES3:RES0} &= \text{ARG1H:ARG1L} \cdot \text{ARG2H:ARG2L} \\ &= (\text{ARG1H} \cdot \text{ARG2H} \cdot 2^{16}) + \\ &\quad (\text{ARG1H} \cdot \text{ARG2L} \cdot 2^8) + \\ &\quad (\text{ARG1L} \cdot \text{ARG2H} \cdot 2^8) + \\ &\quad (\text{ARG1L} \cdot \text{ARG2L}) \end{aligned}$$

## EXAMPLE 8-3: 16 x 16 UNSIGNED MULTIPLY ROUTINE

```

MOVF ARG1L, W
MULWF ARG2L           ; ARG1L * ARG2L->
                       ; PRODH:PRODL

MOVFF PRODH, RES1    ;
MOVFF PRODL, RES0    ;
;

MOVF ARG1H, W
MULWF ARG2H           ; ARG1H * ARG2H->
                       ; PRODH:PRODL

MOVFF PRODH, RES3    ;
MOVFF PRODL, RES2    ;
;

MOVF ARG1L, W
MULWF ARG2H           ; ARG1L * ARG2H->
                       ; PRODH:PRODL

MOVF PRODL, W        ;
ADDWF RES1, F        ; Add cross
MOVF PRODH, W        ; products
ADDWFC RES2, F       ;
CLRF WREG             ;
ADDWFC RES3, F       ;
;

MOVF ARG1H, W        ;
MULWF ARG2L           ; ARG1H * ARG2L->
                       ; PRODH:PRODL

MOVF PRODL, W        ;
ADDWF RES1, F        ; Add cross
MOVF PRODH, W        ; products
ADDWFC RES2, F       ;
CLRF WREG             ;
ADDWFC RES3, F       ;

```

**Example 8-4** shows the sequence to do a 16 x 16 signed multiply. **Equation 8-2** shows the algorithm used. The 32-bit result is stored in four registers (RES3:RES0). To account for the sign bits of the arguments, the MSb for each argument pair is tested and the appropriate subtractions are done.

## EQUATION 8-2: 16 x 16 SIGNED MULTIPLICATION ALGORITHM

$$\begin{aligned} \text{RES3:RES0} &= \text{ARG1H:ARG1L} \cdot \text{ARG2H:ARG2L} \\ &= (\text{ARG1H} \cdot \text{ARG2H} \cdot 2^{16}) + \\ &\quad (\text{ARG1H} \cdot \text{ARG2L} \cdot 2^8) + \\ &\quad (\text{ARG1L} \cdot \text{ARG2H} \cdot 2^8) + \\ &\quad (\text{ARG1L} \cdot \text{ARG2L}) + \\ &\quad (-1 \cdot \text{ARG2H} < 7 > \cdot \text{ARG1H:ARG1L} \cdot 2^{16}) + \\ &\quad (-1 \cdot \text{ARG1H} < 7 > \cdot \text{ARG2H:ARG2L} \cdot 2^{16}) \end{aligned}$$

## EXAMPLE 8-4: 16 x 16 SIGNED MULTIPLY ROUTINE

```

MOVF ARG1L, W
MULWF ARG2L           ; ARG1L * ARG2L ->
                       ; PRODH:PRODL

MOVFF PRODH, RES1    ;
MOVFF PRODL, RES0    ;
;

MOVF ARG1H, W
MULWF ARG2H           ; ARG1H * ARG2H ->
                       ; PRODH:PRODL

MOVFF PRODH, RES3    ;
MOVFF PRODL, RES2    ;
;

MOVF ARG1L, W
MULWF ARG2H           ; ARG1L * ARG2H ->
                       ; PRODH:PRODL

MOVF PRODL, W        ;
ADDWF RES1, F        ; Add cross
MOVF PRODH, W        ; products
ADDWFC RES2, F       ;
CLRF WREG             ;
ADDWFC RES3, F       ;
;

MOVF ARG1H, W        ;
MULWF ARG2L           ; ARG1H * ARG2L ->
                       ; PRODH:PRODL

MOVF PRODL, W        ;
ADDWF RES1, F        ; Add cross
MOVF PRODH, W        ; products
ADDWFC RES2, F       ;
CLRF WREG             ;
ADDWFC RES3, F       ;
;

BTFSS ARG2H, 7       ; ARG2H:ARG2L neg?
BRA SIGN_ARG1        ; no, check ARG1
MOVF ARG1L, W        ;
SUBWF RES2            ;
MOVF ARG1H, W        ;
SUBWFB RES3          ;
;

SIGN_ARG1
BTFSS ARG1H, 7       ; ARG1H:ARG1L neg?
BRA CONT_CODE        ; no, done
MOVF ARG2L, W        ;
SUBWF RES2            ;
MOVF ARG2H, W        ;
SUBWFB RES3          ;
;

CONT_CODE
:

```

## 9.0 INTERRUPTS

Members of the PIC18F87J72 family of devices have multiple interrupt sources and an interrupt priority feature that allows most interrupt sources to be assigned a high-priority level or a low-priority level. The high-priority interrupt vector is at 0008h and the low-priority interrupt vector is at 0018h. High-priority interrupt events will interrupt any low-priority interrupts that may be in progress.

There are thirteen registers which are used to control interrupt operation. These registers are:

- RCON
- INTCON
- INTCON2
- INTCON3
- PIR1, PIR2, PIR3
- PIE1, PIE2, PIE3
- IPR1, IPR2, IPR3

It is recommended that the Microchip header files supplied with MPLAB® IDE be used for the symbolic bit names in these registers. This allows the assembler/compiler to automatically take care of the placement of these bits within the specified register.

In general, interrupt sources have three bits to control their operation. They are:

- **Flag bit** to indicate that an interrupt event occurred
- **Enable bit** that allows program execution to branch to the interrupt vector address when the flag bit is set
- **Priority bit** to select high priority or low priority

The interrupt priority feature is enabled by setting the IPEN bit (RCON<7>). When interrupt priority is enabled, there are two bits which enable interrupts globally. Setting the GIEH bit (INTCON<7>) enables all interrupts that have the priority bit set (high priority). Setting the GIEL bit (INTCON<6>) enables all interrupts that have the priority bit cleared (low priority). When the interrupt flag, enable bit and appropriate global interrupt enable bit are set, the interrupt will vector immediately to address 0008h or 0018h, depending on the priority bit setting. Individual interrupts can be disabled through their corresponding enable bits.

When the IPEN bit is cleared (default state), the interrupt priority feature is disabled and interrupts are compatible with PIC® mid-range devices. In Compatibility mode, the interrupt priority bits for each source have no effect. INTCON<6> is the PEIE bit which enables/disables all peripheral interrupt sources. INTCON<7> is the GIE bit which enables/disables all interrupt sources. All interrupts branch to address 0008h in Compatibility mode.

When an interrupt is responded to, the global interrupt enable bit is cleared to disable further interrupts. If the IPEN bit is cleared, this is the GIE bit. If interrupt priority levels are used, this will be either the GIEH or GIEL bit. High-priority interrupt sources can interrupt a low-priority interrupt. Low-priority interrupts are not processed while high-priority interrupts are in progress.

The return address is pushed onto the stack and the PC is loaded with the interrupt vector address (0008h or 0018h). Once in the Interrupt Service Routine, the source(s) of the interrupt can be determined by polling the interrupt flag bits. The interrupt flag bits must be cleared in software before re-enabling interrupts to avoid recursive interrupts.

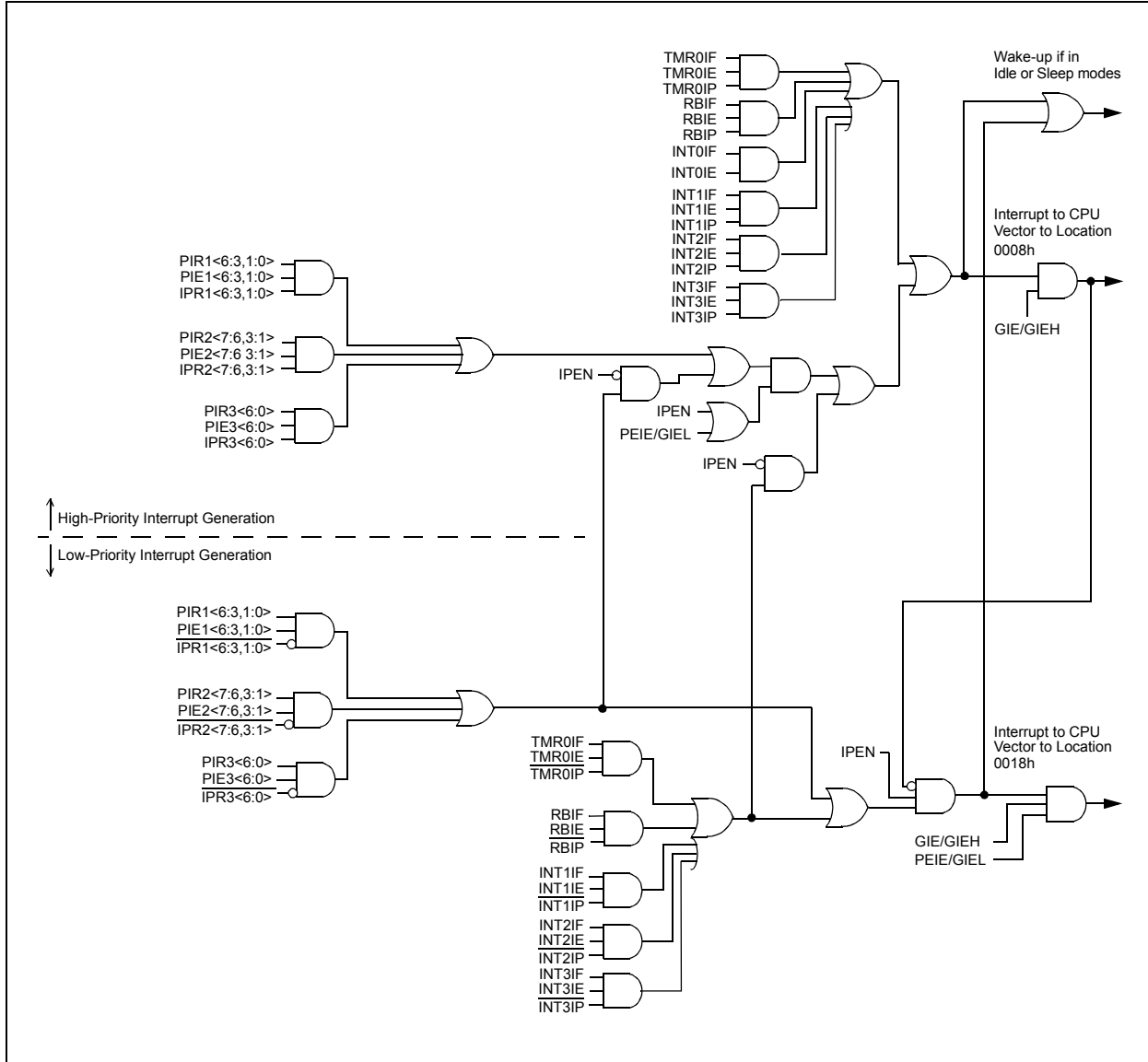
The “return from interrupt” instruction, `RETFIE`, exits the interrupt routine and sets the GIE bit (GIEH or GIEL if priority levels are used) which re-enables interrupts.

For external interrupt events, such as the INTx pins or the PORTB input change interrupt, the interrupt latency will be three to four instruction cycles. The exact latency is the same for one or two-cycle instructions. Individual interrupt flag bits are set regardless of the status of their corresponding enable bit or the GIE bit.

**Note:** Do not use the `MOVFF` instruction to modify any of the Interrupt Control registers while **any** interrupt is enabled. Doing so may cause erratic microcontroller behavior.

# PIC18F87J72

FIGURE 9-1: PIC18F87J72 FAMILY INTERRUPT LOGIC



## 9.1 INTCON Registers

The INTCON registers are readable and writable registers which contain various enable, priority and flag bits.

**Note:** Interrupt flag bits are set when an interrupt condition occurs regardless of the state of its corresponding enable bit or the global interrupt enable bit. User software should ensure the appropriate interrupt flag bits are clear prior to enabling an interrupt. This feature allows for software polling.

### REGISTER 9-1: INTCON: INTERRUPT CONTROL REGISTER

R/W-0	R/W-0	R/W-0	R/W-0	R/W-0	R/W-0	R/W-0	R/W-x
GIE/GIEH	PEIE/GIEL	TMR0IE	INT0IE	RBIE	TMR0IF	INT0IF	RBIF <sup>(1)</sup>
bit 7							bit 0

**Legend:**

R = Readable bit	W = Writable bit	U = Unimplemented bit, read as '0'
-n = Value at POR	'1' = Bit is set	'0' = Bit is cleared
		x = Bit is unknown

- bit 7      **GIE/GIEH:** Global Interrupt Enable bit  
When IPEN = 0:  
 1 = Enables all unmasked interrupts  
 0 = Disables all interrupts  
When IPEN = 1:  
 1 = Enables all high-priority interrupts  
 0 = Disables all interrupts
- bit 6      **PEIE/GIEL:** Peripheral Interrupt Enable bit  
When IPEN = 0:  
 1 = Enables all unmasked peripheral interrupts  
 0 = Disables all peripheral interrupts  
When IPEN = 1:  
 1 = Enables all low-priority peripheral interrupts  
 0 = Disables all low-priority peripheral interrupts
- bit 5      **TMR0IE:** TMR0 Overflow Interrupt Enable bit  
 1 = Enables the TMR0 overflow interrupt  
 0 = Disables the TMR0 overflow interrupt
- bit 4      **INT0IE:** INT0 External Interrupt Enable bit  
 1 = Enables the INT0 external interrupt  
 0 = Disables the INT0 external interrupt
- bit 3      **RBIE:** RB Port Change Interrupt Enable bit  
 1 = Enables the RB port change interrupt  
 0 = Disables the RB port change interrupt
- bit 2      **TMR0IF:** TMR0 Overflow Interrupt Flag bit  
 1 = TMR0 register has overflowed (must be cleared in software)  
 0 = TMR0 register did not overflow
- bit 1      **INT0IF:** INT0 External Interrupt Flag bit  
 1 = The INT0 external interrupt occurred (must be cleared in software)  
 0 = The INT0 external interrupt did not occur
- bit 0      **RBIF:** RB Port Change Interrupt Flag bit<sup>(1)</sup>  
 1 = At least one of the RB<7:4> pins changed state (must be cleared in software)  
 0 = None of the RB<7:4> pins have changed state

**Note 1:** A mismatch condition will continue to set this bit. Reading PORTB, then waiting one instruction cycle, will end the mismatch condition and allow the bit to be cleared.

# PIC18F87J72

## REGISTER 9-2: INTCON2: INTERRUPT CONTROL REGISTER 2

R/W-1	R/W-1	R/W-1	R/W-1	R/W-1	R/W-1	R/W-1	R/W-1
$\overline{\text{RBPU}}$	INTEDG0	INTEDG1	INTEDG2	INTEDG3	TMR0IP	INT3IP	RBIP
bit 7							bit 0

### Legend:

R = Readable bit

W = Writable bit

U = Unimplemented bit, read as '0'

-n = Value at POR

'1' = Bit is set

'0' = Bit is cleared

x = Bit is unknown

- bit 7       **$\overline{\text{RBPU}}$** : PORTB Pull-up Enable bit  
 1 = All PORTB pull-ups are disabled  
 0 = PORTB pull-ups are enabled by individual port latch values
- bit 6      **INTEDG0**: External Interrupt 0 Edge Select bit  
 1 = Interrupt on rising edge  
 0 = Interrupt on falling edge
- bit 5      **INTEDG1**: External Interrupt 1 Edge Select bit  
 1 = Interrupt on rising edge  
 0 = Interrupt on falling edge
- bit 4      **INTEDG2**: External Interrupt 2 Edge Select bit  
 1 = Interrupt on rising edge  
 0 = Interrupt on falling edge
- bit 3      **INTEDG3**: External Interrupt 3 Edge Select bit  
 1 = Interrupt on rising edge  
 0 = Interrupt on falling edge
- bit 2      **TMR0IP**: TMR0 Overflow Interrupt Priority bit  
 1 = High priority  
 0 = Low priority
- bit 1      **INT3IP**: INT3 External Interrupt Priority bit  
 1 = High priority  
 0 = Low priority
- bit 0      **RBIP**: RB Port Change Interrupt Priority bit  
 1 = High priority  
 0 = Low priority

**Note:** Interrupt flag bits are set when an interrupt condition occurs regardless of the state of its corresponding enable bit or the global interrupt enable bit. User software should ensure the appropriate interrupt flag bits are clear prior to enabling an interrupt. This feature allows for software polling.



## REGISTER 9-3: INTCON3: INTERRUPT CONTROL REGISTER 3

R/W-1	R/W-1	R/W-0	R/W-0	R/W-0	R/W-0	R/W-0	R/W-0
INT2IP	INT1IP	INT3IE	INT2IE	INT1IE	INT3IF	INT2IF	INT1IF
bit 7							bit 0

### Legend:

R = Readable bit	W = Writable bit	U = Unimplemented bit, read as '0'
-n = Value at POR	'1' = Bit is set	'0' = Bit is cleared
		x = Bit is unknown

- bit 7      **INT2IP:** INT2 External Interrupt Priority bit  
             1 = High priority  
             0 = Low priority
- bit 6      **INT1IP:** INT1 External Interrupt Priority bit  
             1 = High priority  
             0 = Low priority
- bit 5      **INT3IE:** INT3 External Interrupt Enable bit  
             1 = Enables the INT3 external interrupt  
             0 = Disables the INT3 external interrupt
- bit 4      **INT2IE:** INT2 External Interrupt Enable bit  
             1 = Enables the INT2 external interrupt  
             0 = Disables the INT2 external interrupt
- bit 3      **INT1IE:** INT1 External Interrupt Enable bit  
             1 = Enables the INT1 external interrupt  
             0 = Disables the INT1 external interrupt
- bit 2      **INT3IF:** INT3 External Interrupt Flag bit  
             1 = The INT3 external interrupt occurred (must be cleared in software)  
             0 = The INT3 external interrupt did not occur
- bit 1      **INT2IF:** INT2 External Interrupt Flag bit  
             1 = The INT2 external interrupt occurred (must be cleared in software)  
             0 = The INT2 external interrupt did not occur
- bit 0      **INT1IF:** INT1 External Interrupt Flag bit  
             1 = The INT1 external interrupt occurred (must be cleared in software)  
             0 = The INT1 external interrupt did not occur

**Note:** Interrupt flag bits are set when an interrupt condition occurs regardless of the state of its corresponding enable bit or the global interrupt enable bit. User software should ensure the appropriate interrupt flag bits are clear prior to enabling an interrupt. This feature allows for software polling.

# PIC18F87J72

## 9.2 PIR Registers

The PIR registers contain the individual flag bits for the peripheral interrupts. Due to the number of peripheral interrupt sources, there are three Peripheral Interrupt Request (Flag) registers (PIR1, PIR2, PIR3).

**Note 1:** Interrupt flag bits are set when an interrupt condition occurs regardless of the state of its corresponding enable bit or the Global Interrupt Enable bit, GIE (INTCON<7>).

**2:** User software should ensure the appropriate interrupt flag bits are cleared prior to enabling an interrupt and after servicing that interrupt.

### REGISTER 9-4: PIR1: PERIPHERAL INTERRUPT REQUEST (FLAG) REGISTER 1

U-0	R/W-0	R-0	R-0	R/W-0	U-0	R/W-0	R/W-0
—	ADIF	RC1IF	TX1IF	SSPIF	—	TMR2IF	TMR1IF
bit 7						bit 0	

Legend:

R = Readable bit

W = Writable bit

U = Unimplemented bit, read as '0'

-n = Value at POR

'1' = Bit is set

'0' = Bit is cleared

x = Bit is unknown

bit 7 **Unimplemented:** Read as '0'

bit 6 **ADIF:** A/D Converter Interrupt Flag bit

1 = An A/D conversion completed (must be cleared in software)

0 = The A/D conversion is not complete

bit 5 **RC1IF:** EUSART Receive Interrupt Flag bit

1 = The EUSART receive buffer, RCREG1, is full (cleared when RCREG1 is read)

0 = The EUSART receive buffer is empty

bit 4 **TX1IF:** EUSART Transmit Interrupt Flag bit

1 = The EUSART transmit buffer, TXREG1, is empty (cleared when TXREG1 is written)

0 = The EUSART transmit buffer is full

bit 3 **SSPIF:** Master Synchronous Serial Port Interrupt Flag bit

1 = The transmission/reception is complete (must be cleared in software)

0 = Waiting to transmit/receive

bit 2 **Unimplemented:** Read as '0'

bit 1 **TMR2IF:** TMR2 to PR2 Match Interrupt Flag bit

1 = TMR2 to PR2 match occurred (must be cleared in software)

0 = No TMR2 to PR2 match occurred

bit 0 **TMR1IF:** TMR1 Overflow Interrupt Flag bit

1 = TMR1 register overflowed (must be cleared in software)

0 = TMR1 register did not overflow

## REGISTER 9-5: PIR2: PERIPHERAL INTERRUPT REQUEST (FLAG) REGISTER 2

R/W-0	R/W-0	U-0	U-0	R/W-0	R/W-0	R/W-0	U-0
OSCFIF	CMIF	—	—	BCLIF	LVDIF	TMR3IF	—
bit 7							bit 0

### Legend:

R = Readable bit	W = Writable bit	U = Unimplemented bit, read as '0'
-n = Value at POR	'1' = Bit is set	'0' = Bit is cleared      x = Bit is unknown

- bit 7      **OSCFIF:** Oscillator Fail Interrupt Flag bit  
           1 = Device oscillator failed, clock input has changed to INTOSC (must be cleared in software)  
           0 = Device clock operating
- bit 6      **CMIF:** Comparator Interrupt Flag bit  
           1 = Comparator input has changed (must be cleared in software)  
           0 = Comparator input has not changed
- bit 5-4    **Unimplemented:** Read as '0'
- bit 3      **BCLIF:** Bus Collision Interrupt Flag bit  
           1 = A bus collision occurred (must be cleared in software)  
           0 = No bus collision occurred
- bit 2      **LVDIF:** Low-Voltage Detect Interrupt Flag bit  
           1 = A low-voltage condition occurred (must be cleared in software)  
           0 = The device voltage is above the regulator's low-voltage trip point
- bit 1      **TMR3IF:** TMR3 Overflow Interrupt Flag bit  
           1 = TMR3 register overflowed (must be cleared in software)  
           0 = TMR3 register did not overflow
- bit 0      **Unimplemented:** Read as '0'

# PIC18F87J72

## REGISTER 9-6: PIR3: PERIPHERAL INTERRUPT REQUEST (FLAG) REGISTER 3

U-0	R/W-0	R-0	R-0	R/W-0	R/W-0	R/W-0	R/W-0
—	LCDIF	RC2IF	TX2IF	CTMUIF	CCP2IF	CCP1IF	RTCCIF
bit 7							bit 0

### Legend:

R = Readable bit                      W = Writable bit                      U = Unimplemented bit, read as '0'  
 -n = Value at POR                      '1' = Bit is set                      '0' = Bit is cleared                      x = Bit is unknown

- bit 7                      **Unimplemented:** Read as '0'
- bit 6                      **LCDIF:** LCD Interrupt Flag bit (valid when Type-B waveform with Non-Static mode is selected)  
                                  1 = LCD data of all COMs is output (must be cleared in software)  
                                  0 = LCD data of all COMs is not yet output
- bit 5                      **RC2IF:** AUSART Receive Interrupt Flag bit  
                                  1 = The AUSART receive buffer, RCREG2, is full (cleared when RCREG2 is read)  
                                  0 = The AUSART receive buffer is empty
- bit 4                      **TX2IF:** AUSART Transmit Interrupt Flag bit  
                                  1 = The AUSART transmit buffer, TXREG2, is empty (cleared when TXREG2 is written)  
                                  0 = The AUSART transmit buffer is full
- bit 3                      **CTMUIF:** CTMU Interrupt Flag bit  
                                  1 = CTMU interrupt occurred (must be cleared in software)  
                                  0 = No CTMU interrupt occurred
- bit 2                      **CCP2IF:** CCP2 Interrupt Flag bit  
                                  Capture mode:  
                                  1 = A TMR1/TMR3 register capture occurred (must be cleared in software)  
                                  0 = No TMR1/TMR3 register capture occurred  
                                  Compare mode:  
                                  1 = A TMR1/TMR3 register compare match occurred (must be cleared in software)  
                                  0 = No TMR1/TMR3 register compare match occurred  
                                  PWM mode:  
                                  Unused in this mode.
- bit 1                      **CCP1IF:** CCP1 Interrupt Flag bit  
                                  Capture mode:  
                                  1 = A TMR1/TMR3 register capture occurred (must be cleared in software)  
                                  0 = No TMR1/TMR3 register capture occurred  
                                  Compare mode:  
                                  1 = A TMR1/TMR3 register compare match occurred (must be cleared in software)  
                                  0 = No TMR1/TMR3 register compare match occurred  
                                  PWM mode:  
                                  Unused in this mode.
- bit 0                      **RTCCIF:** RTCC Interrupt Flag bit  
                                  1 = RTCC interrupt occurred (must be cleared in software)  
                                  0 = No RTCC interrupt occurred

## 9.3 PIE Registers

The PIE registers contain the individual enable bits for the peripheral interrupts. Due to the number of peripheral interrupt sources, there are three Peripheral Interrupt Enable registers (PIE1, PIE2, PIE3). When IPEN = 0, the PEIE bit must be set to enable any of these peripheral interrupts.

**REGISTER 9-7: PIE1: PERIPHERAL INTERRUPT ENABLE REGISTER 1**

U-0	R/W-0	R/W-0	R/W-0	R/W-0	U-0	R/W-0	R/W-0
—	ADIE	RC1IE	TX1IE	SSPIE	—	TMR2IE	TMR1IE
bit 7							bit 0

**Legend:**

R = Readable bit	W = Writable bit	U = Unimplemented bit, read as '0'
-n = Value at POR	'1' = Bit is set	'0' = Bit is cleared
		x = Bit is unknown

- bit 7      **Unimplemented:** Read as '0'
- bit 6      **ADIE:** A/D Converter Interrupt Enable bit  
1 = Enables the A/D interrupt  
0 = Disables the A/D interrupt
- bit 5      **RC1IE:** EUSART Receive Interrupt Enable bit  
1 = Enables the EUSART receive interrupt  
0 = Disables the EUSART receive interrupt
- bit 4      **TX1IE:** EUSART Transmit Interrupt Enable bit  
1 = Enables the EUSART transmit interrupt  
0 = Disables the EUSART transmit interrupt
- bit 3      **SSPIE:** Master Synchronous Serial Port Interrupt Enable bit  
1 = Enables the MSSP interrupt  
0 = Disables the MSSP interrupt
- bit 2      **Unimplemented:** Read as '0'
- bit 1      **TMR2IE:** TMR2 to PR2 Match Interrupt Enable bit  
1 = Enables the TMR2 to PR2 match interrupt  
0 = Disables the TMR2 to PR2 match interrupt
- bit 0      **TMR1IE:** TMR1 Overflow Interrupt Enable bit  
1 = Enables the TMR1 overflow interrupt  
0 = Disables the TMR1 overflow interrupt

# PIC18F87J72

## REGISTER 9-8: PIE2: PERIPHERAL INTERRUPT ENABLE REGISTER 2

R/W-0	R/W-0	U-0	U-0	R/W-0	R/W-0	R/W-0	U-0
OSCFIE	CMIE	—	—	BCLIE	LVDIE	TMR3IE	—
bit 7							bit 0

### Legend:

R = Readable bit

W = Writable bit

U = Unimplemented bit, read as '0'

-n = Value at POR

'1' = Bit is set

'0' = Bit is cleared

x = Bit is unknown

- bit 7      **OSCFIE:** Oscillator Fail Interrupt Enable bit  
1 = Enabled  
0 = Disabled
- bit 6      **CMIE:** Comparator Interrupt Enable bit  
1 = Enabled  
0 = Disabled
- bit 5-4    **Unimplemented:** Read as '0'
- bit 3      **BCLIE:** Bus Collision Interrupt Enable bit  
1 = Enabled  
0 = Disabled
- bit 2      **LVDIE:** Low-Voltage Detect Interrupt Enable bit  
1 = Enabled  
0 = Disabled
- bit 1      **TMR3IE:** TMR3 Overflow Interrupt Enable bit  
1 = Enabled  
0 = Disabled
- bit 0      **Unimplemented:** Read as '0'

## REGISTER 9-9: PIE3: PERIPHERAL INTERRUPT ENABLE REGISTER 3

U-0	R/W-0	R-0	R-0	R/W-0	R/W-0	R/W-0	R/W-0
—	LCDIE	RC2IE	TX2IE	CTMUIE	CCP2IE	CCP1IE	RTCCIE
bit 7							bit 0

### Legend:

R = Readable bit                      W = Writable bit                      U = Unimplemented bit, read as '0'  
 -n = Value at POR                      '1' = Bit is set                      '0' = Bit is cleared                      x = Bit is unknown

- bit 7                      **Unimplemented:** Read as '0'
- bit 6                      **LCDIE:** LCD Interrupt Enable bit (valid when Type-B waveform with Non-Static mode is selected)
  - 1 = Enabled
  - 0 = Disabled
- bit 5                      **RC2IE:** AUSART Receive Interrupt Enable bit
  - 1 = Enabled
  - 0 = Disabled
- bit 4                      **TX2IE:** AUSART Transmit Interrupt Enable bit
  - 1 = Enabled
  - 0 = Disabled
- bit 3                      **CTMUIE:** CTMU Interrupt Enable bit
  - 1 = Enabled
  - 0 = Disabled
- bit 2                      **CCP2IE:** CCP2 Interrupt Enable bit
  - 1 = Enabled
  - 0 = Disabled
- bit 1                      **CCP1IE:** CCP1 Interrupt Enable bit
  - 1 = Enables the CCP1 interrupt
  - 0 = Disables the CCP1 interrupt
- bit 0                      **RTCCIE:** RTCC Interrupt Enable bit
  - 1 = Enabled
  - 0 = Disabled

# PIC18F87J72

## 9.4 IPR Registers

The IPR registers contain the individual priority bits for the peripheral interrupts. Due to the number of peripheral interrupt sources, there are three Peripheral Interrupt Priority registers (IPR1, IPR2, IPR3). Using the priority bits requires that the Interrupt Priority Enable (IPEN) bit be set.

### REGISTER 9-10: IPR1: PERIPHERAL INTERRUPT PRIORITY REGISTER 1

U-0	R/W-1	R/W-1	R/W-1	R/W-1	U-0	R/W-1	R/W-1
—	ADIP	RC1IP	TX1IP	SSPIP	—	TMR2IP	TMR1IP
bit 7							bit 0

#### Legend:

R = Readable bit

W = Writable bit

U = Unimplemented bit, read as '0'

-n = Value at POR

'1' = Bit is set

'0' = Bit is cleared

x = Bit is unknown

bit 7	<b>Unimplemented:</b> Read as '0'
bit 6	<b>ADIP:</b> A/D Converter Interrupt Priority bit 1 = High priority 0 = Low priority
bit 5	<b>RC1IP:</b> EUSART Receive Interrupt Priority bit 1 = High priority 0 = Low priority
bit 4	<b>TX1IP:</b> EUSART Transmit Interrupt Priority bit 1 = High priority 0 = Low priority
bit 3	<b>SSPIP:</b> Master Synchronous Serial Port Interrupt Priority bit 1 = High priority 0 = Low priority
bit 2	<b>Unimplemented:</b> Read as '0'
bit 1	<b>TMR2IP:</b> TMR2 to PR2 Match Interrupt Priority bit 1 = High priority 0 = Low priority
bit 0	<b>TMR1IP:</b> TMR1 Overflow Interrupt Priority bit 1 = High priority 0 = Low priority



## REGISTER 9-11: IPR2: PERIPHERAL INTERRUPT PRIORITY REGISTER 2

R/W-1	R/W-1	U-0	U-0	R/W-1	R/W-1	R/W-1	U-0
OSCFIP	CMIP	—	—	BCLIP	LVDIP	TMR3IP	—
bit 7							bit 0

### Legend:

R = Readable bit	W = Writable bit	U = Unimplemented bit, read as '0'
-n = Value at POR	'1' = Bit is set	'0' = Bit is cleared
		x = Bit is unknown

- bit 7      **OSCFIP:** Oscillator Fail Interrupt Priority bit  
           1 = High priority  
           0 = Low priority
- bit 6      **CMIP:** Comparator Interrupt Priority bit  
           1 = High priority  
           0 = Low priority
- bit 5-4    **Unimplemented:** Read as '0'
- bit 3      **BCLIP:** Bus Collision Interrupt Priority bit  
           1 = High priority  
           0 = Low priority
- bit 2      **LVDIP:** Low-Voltage Detect Interrupt Priority bit  
           1 = High priority  
           0 = Low priority
- bit 1      **TMR3IP:** TMR3 Overflow Interrupt Priority bit  
           1 = High priority  
           0 = Low priority
- bit 0      **Unimplemented:** Read as '0'

# PIC18F87J72

## REGISTER 9-12: IPR3: PERIPHERAL INTERRUPT PRIORITY REGISTER 3

U-0	R/W-1	R-1	R-1	R/W-1	R/W-1	R/W-1	R/W-1
—	LCDIP	RC2IP	TX2IP	CTMUIP	CCP2IP	CCP1IP	RTCCIP
bit 7							bit 0

### Legend:

R = Readable bit

W = Writable bit

U = Unimplemented bit, read as '0'

-n = Value at POR

'1' = Bit is set

'0' = Bit is cleared

x = Bit is unknown

- bit 7      **Unimplemented:** Read as '0'
- bit 6      **LCDIP:** LCD Interrupt Priority bit (valid when Type-B waveform with Non-Static mode is selected)  
             1 = High priority  
             0 = Low priority
- bit 5      **RC2IP:** AUSART Receive Priority Flag bit  
             1 = High priority  
             0 = Low priority
- bit 4      **TX2IP:** AUSART Transmit Interrupt Priority bit  
             1 = High priority  
             0 = Low priority
- bit 3      **CTMUIP:** CTMU Interrupt Priority bit  
             1 = High priority  
             0 = Low priority
- bit        **CCP2IP:** CCP2 Interrupt Priority bit  
             1 = High priority  
             0 = Low priority
- bit        **CCP1IP:** CCP1 Interrupt Priority bit  
             1 = High priority  
             0 = Low priority
- bit 0      **RTCCIP:** RTCC Interrupt Priority bit  
             1 = High priority  
             0 = Low priority

## 9.5 RCON Register

The RCON register contains bits used to determine the cause of the last Reset or wake-up from Idle or Sleep modes. RCON also contains the bit that enables interrupt priorities (IPEN).

### REGISTER 9-13: RCON: RESET CONTROL REGISTER

R/W-0	U-0	R/W-1	R/W-1	R-1	R-1	R/W-0	R/W-0
IPEN	—	$\overline{\text{CM}}$	$\overline{\text{RI}}$	$\overline{\text{TO}}$	$\overline{\text{PD}}$	$\overline{\text{POR}}$	$\overline{\text{BOR}}$
bit 7							bit 0

#### Legend:

R = Readable bit	W = Writable bit	U = Unimplemented bit, read as '0'
-n = Value at POR	'1' = Bit is set	'0' = Bit is cleared
		x = Bit is unknown

- bit 7      **IPEN:** Interrupt Priority Enable bit  
           1 = Enable priority levels on interrupts  
           0 = Disable priority levels on interrupts (PIC16CXXX Compatibility mode)
- bit 6      **Unimplemented:** Read as '0'
- bit 5      **CM:** Configuration Mismatch Flag bit  
           1 = A Configuration Mismatch Reset has not occurred  
           0 = A Configuration Mismatch Reset has occurred (Must be subsequently set in software.)
- bit 4      **RI:**  $\overline{\text{RESET}}$  Instruction Flag bit  
           For details of bit operation, see [Register 5-1](#).
- bit 3      **TO:** Watchdog Timer Time-out Flag bit  
           For details of bit operation, see [Register 5-1](#).
- bit 2      **PD:** Power-Down Detection Flag bit  
           For details of bit operation, see [Register 5-1](#).
- bit 1      **POR:** Power-on Reset Status bit  
           For details of bit operation, see [Register 5-1](#).
- bit 0      **BOR:** Brown-out Reset Status bit  
           For details of bit operation, see [Register 5-1](#).

# PIC18F87J72

## 9.6 INTx Pin Interrupts

External interrupts on the RB0/INT0, RB1/INT1, RB2/INT2 and RB3/INT3 pins are edge-triggered. If the corresponding INTEDGx bit in the INTCON2 register is set (= 1), the interrupt is triggered by a rising edge; if the bit is clear, the trigger is on the falling edge. When a valid edge appears on the RBx/INTx pin, the corresponding flag bit, INTxIF, is set. This interrupt can be disabled by clearing the corresponding enable bit, INTxIE. Flag bit, INTxIF, must be cleared in software in the Interrupt Service Routine (ISR) before re-enabling the interrupt.

All external interrupts (INT0, INT1, INT2 and INT3) can wake-up the processor from the power-managed modes if bit INTxIE was set prior to going into the power-managed modes. If the Global Interrupt Enable bit, GIE, is set, the processor will branch to the interrupt vector following wake-up.

Interrupt priority for INT1, INT2 and INT3 is determined by the value contained in the interrupt priority bits, INT1IP (INTCON3<6>), INT2IP (INTCON3<7>) and INT3IP (INTCON2<1>). There is no priority bit associated with INT0. It is always a high-priority interrupt source.

## 9.7 TMR0 Interrupt

In 8-bit mode (which is the default), an overflow in the TMR0 register (FFh → 00h) will set flag bit, TMR0IF. In 16-bit mode, an overflow in the TMR0H:TMR0L register pair (FFFFh → 0000h) will set TMR0IF. The interrupt can be enabled/disabled by setting/clearing enable bit, TMR0IE (INTCON<5>). Interrupt priority for Timer0 is determined by the value contained in the interrupt priority bit, TMR0IP (INTCON2<2>). See [Section 11.0 “Timer0 Module”](#) for further details on the Timer0 module.

## 9.8 PORTB Interrupt-on-Change

An input change on PORTB<7:4> sets flag bit, RBIF (INTCON<0>). The interrupt can be enabled/disabled by setting/clearing enable bit, RBIE (INTCON<3>). Interrupt priority for PORTB interrupt-on-change is determined by the value contained in the interrupt priority bit, RBIP (INTCON2<0>).

## 9.9 Context Saving During Interrupts

During interrupts, the return PC address is saved on the stack. Additionally, the WREG, STATUS and BSR registers are saved on the Fast Return Stack. If a fast return from interrupt is not used (see [Section 6.3 “Data Memory Organization”](#)), the user may need to save the WREG, STATUS and BSR registers on entry to the Interrupt Service Routine. Depending on the user’s application, other registers may also need to be saved. [Example 9-1](#) saves and restores the WREG, STATUS and BSR registers during an Interrupt Service Routine.

### EXAMPLE 9-1: SAVING STATUS, WREG AND BSR REGISTERS IN RAM

```
MOVWF  W_TEMP          ; W_TEMP is in virtual bank
MOVFF  STATUS, STATUS_TEMP ; STATUS_TEMP located anywhere
MOVFF  BSR, BSR_TEMP     ; BSR_TEMP located anywhere
;
; USER ISR CODE
;
MOVFF  BSR_TEMP, BSR     ; Restore BSR
MOVF   W_TEMP, W        ; Restore WREG
MOVFF  STATUS_TEMP, STATUS ; Restore STATUS
```

## 10.0 I/O PORTS

Depending on the features enabled, there are up to seven ports available. Some pins of the I/O ports are multiplexed with an alternate function from the peripheral features on the device. In general, when a peripheral is enabled, that pin may not be used as a general purpose I/O pin.

Each port has three memory mapped registers for its operation:

- TRIS register (Data Direction register)
- PORT register (reads the levels on the pins of the device)
- LAT register (Output Latch register)

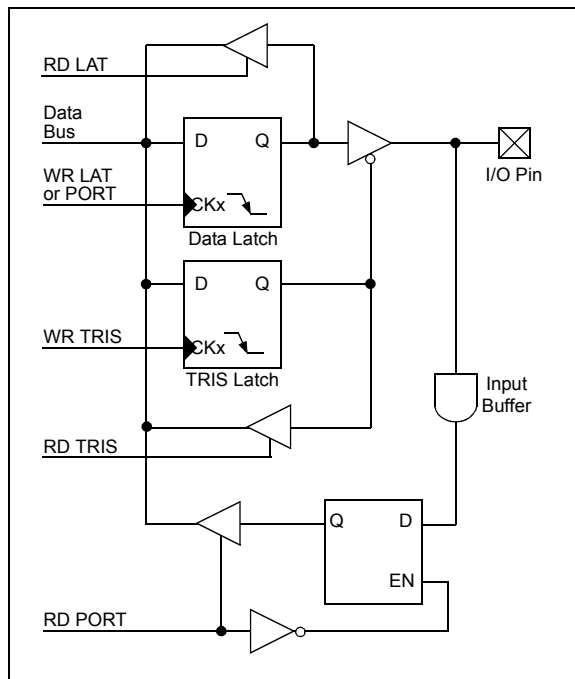
Reading the PORT register reads the current status of the pins, whereas writing to the PORT register, writes to the Output Latch (LAT) register.

Setting a TRIS bit (= 1) makes the corresponding PORT pin an input (i.e., put the corresponding output driver in a high-impedance mode). Clearing a TRIS bit (= 0) makes the corresponding PORT pin an output (i.e., put the contents of the corresponding LAT bit on the selected pin).

The Output Latch (LAT register) is useful for read-modify-write operations on the value that the I/O pins are driving. Read-modify-write operations on the LAT register read and write the latched output value for the PORT register.

A simplified model of a generic I/O port, without the interfaces to other peripherals, is shown in [Figure 10-1](#).

**FIGURE 10-1: GENERIC I/O PORT OPERATION**



## 10.1 I/O Port Pin Capabilities

When developing an application, the capabilities of the port pins must be considered. Outputs on some pins have higher output drive strength than others. Similarly, some pins can tolerate higher than VDD input levels.

### 10.1.1 INPUT PINS AND VOLTAGE CONSIDERATIONS

The voltage tolerance of pins used as device inputs is dependent on the pin's input function. Most of the pins that are used as digital only inputs are able to handle DC voltages up to 5.5V, a level typical for digital logic circuits. In contrast, pins that also have analog input functions of any kind can only tolerate voltages up to VDD. [Table](#) summarizes the input voltage capabilities of the I/O pins.

Refer to [Section 29.0 "Electrical Characteristics"](#) for more details. Voltage excursions beyond VDD on these pins should be avoided.

**TABLE 10-1: INPUT VOLTAGE TOLERANCE**

PORT or Pin	Tolerated Input	Description
PORTA<7:0>	VDD	Only VDD input levels tolerated.
PORTC<1:0>		
PORTF<1,0>		
PORTF<7:1>		
PORTG<3:2, 0>		
PORTB<7:0>	5.5V	Tolerates input levels above VDD, useful for most standard logic.
PORTC<7:2>		
PORTD<7:0>		
PORTE<7:2>		
PORTG<4,1>		

### 10.1.2 PIN OUTPUT DRIVE

When used as digital I/O, the output pin drive strengths vary for groups of pins intended to meet the needs for a variety of applications. In general, there are three classes of output pins in terms of drive capability.

PORTB and PORTC, as well as PORTA<7:6>, are designed to drive higher current loads, such as LEDs. PORTD, PORTE and PORTJ can also drive LEDs but only those with smaller current requirements. PORTF, PORTG and PORTH, along with PORTA<5:0>, have the lowest drive level but are capable of driving normal digital circuit loads with a high input impedance. Regardless of which port it is located on, all output pins in LCD Segment or common-mode have sufficient output to directly drive a display.

[Table 10-2](#) summarizes the output capabilities of the ports. Refer to the [Absolute Maximum Ratings<sup>\(†\)</sup>](#) in [Section 29.0 "Electrical Characteristics"](#) for more details.

# PIC18F87J72

**TABLE 10-2: OUTPUT DRIVE LEVELS FOR VARIOUS PORTS**

Low	Medium	High
PORTA<5:0>	PORTD	PORTA<7:6>
PORTF	PORTE	PORTB
PORTG		PORTC

## 10.1.3 PULL-UP CONFIGURATION

Four of the I/O ports (PORTB, PORTD, PORTE and PORTJ) implement configurable weak pull-ups on all pins. These are internal pull-ups that allow floating digital input signals to be pulled to a consistent level without the use of external resistors.

The pull-ups are enabled with a single bit for each of the ports:  $\overline{\text{RBPU}}$  (INTCON2<7>) for PORTB, and RDP<sub>U</sub>, REP<sub>U</sub> and PJPU (PORTG<7:5>) for the other ports.

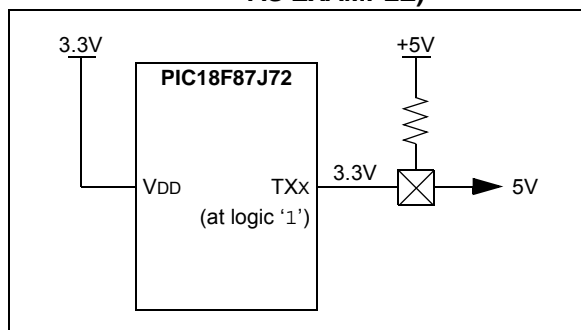
## 10.1.4 OPEN-DRAIN OUTPUTS

The output pins for several peripherals are also equipped with a configurable, open-drain output option. This allows the peripherals to communicate with external digital logic, operating at a higher voltage level, without the use of level translators.

The open-drain option is implemented on port pins specifically associated with the data and clock outputs of the USARTs, the MSSP module (in SPI mode) and the CCP modules. This option is selectively enabled by setting the open-drain control bit for the corresponding module in TRISG and LATG. Their configuration is discussed in more detail in [Section 10.4 “PORTC, TRISC and LATC Registers”](#), [Section 10.6 “PORTE, TRISE and LATE Registers”](#) and [Section 10.8 “PORTG, TRISG and LATG Registers”](#).

When the open-drain option is required, the output pin must also be tied through an external pull-up resistor provided by the user to a higher voltage level, up to 5V ([Figure 10-2](#)). When a digital logic high signal is output, it is pulled up to the higher voltage level.

**FIGURE 10-2: USING THE OPEN-DRAIN OUTPUT (USART SHOWN AS EXAMPLE)**



## 10.2 PORTA, TRISA and LATA Registers

PORTA is an 8-bit wide, bidirectional port. The corresponding Data Direction and Output Latch registers are TRISA and LATA.

RA4/T0CKI is a Schmitt Trigger input. All other PORTA pins have TTL input levels and full CMOS output drivers.

The RA4 pin is multiplexed with the Timer0 clock input and one of the LCD segment drives. RA5 and RA<3:0> are multiplexed with analog inputs for the A/D Converter.

The operation of the analog inputs as A/D Converter inputs is selected by clearing or setting the PCFG<3:0> control bits in the ADCON1 register. The corresponding TRISA bits control the direction of these pins, even when they are being used as analog inputs. The user must ensure the bits in the TRISA register are maintained set when using them as analog inputs.

**Note:** RA5 and RA<3:0> are configured as analog inputs on any Reset and are read as '0'. RA4 is configured as a digital input.

OSC2/CLKO/RA6 and OSC1/CLKI/RA7 normally serve as the external circuit connections for the external (primary) oscillator circuit (HS Oscillator modes) or the external clock input and output (EC Oscillator modes). In these cases, RA6 and RA7 are not available as digital I/O and their corresponding TRIS and LAT bits are read as '0'. When the device is configured to use INTOSC or INTRC as the default oscillator mode (FOSC2 Configuration bit is '0'), RA6 and RA7 are automatically configured as digital I/O. The oscillator and clock in/clock out functions are disabled.

RA1, RA4 and RA5 are multiplexed with LCD segment drives, controlled by bits in the LCDSE1 and LCDSE2 registers. I/O port functionality is only available when the LCD segments are disabled.

### EXAMPLE 10-1: INITIALIZING PORTA

```
CLRF   PORTA   ; Initialize PORTA by
           ; clearing output latches
CLRF   LATA    ; Alternate method to
           ; clear output data latches
MOVLW  07h    ; Configure A/D
MOVWF  ADCON1 ; for digital inputs
MOVLW  0BFh   ; Value used to initialize
           ; data direction
MOVWF  TRISA  ; Set RA<7, 5:0> as inputs,
           ; RA<6> as output
```

**TABLE 10-3: PORTA FUNCTIONS**

Pin Name	Function	TRIS Setting	I/O	I/O Type	Description
RA0/AN0	RA0	0	O	DIG	LATA<0> data output; not affected by analog input.
		1	I	TTL	PORTA<0> data input; disabled when analog input is enabled.
	AN0	1	I	ANA	A/D Input Channel 0. Default input configuration on POR; does not affect digital output.
RA1/AN1/SEG18	RA1	0	O	DIG	LATA<1> data output; not affected by analog input.
		1	I	TTL	PORTA<1> data input; disabled when analog input is enabled.
	AN1	1	I	ANA	A/D Input Channel 1. Default input configuration on POR; does not affect digital output.
	SEG18	x	O	ANA	LCD Segment 18 output; disables all other pin functions.
RA2/AN2/VREF-	RA2	0	O	DIG	LATA<2> data output; not affected by analog input.
		1	I	TTL	PORTA<2> data input; disabled when analog functions are enabled.
	AN2	1	I	ANA	A/D Input Channel 2. Default input configuration on POR.
	VREF-	1	I	ANA	A/D and comparator low reference voltage input.
RA3/AN3/VREF+	RA3	0	O	DIG	LATA<3> data output; not affected by analog input.
		1	I	TTL	PORTA<3> data input; disabled when analog input is enabled.
	AN3	1	I	ANA	A/D Input Channel 3. Default input configuration on POR.
	VREF+	1	I	ANA	A/D and comparator high reference voltage input.
RA4/T0CKI/SEG14	RA4	0	O	DIG	LATA<4> data output.
		1	I	ST	PORTA<4> data input. Default configuration on POR.
	T0CKI	x	I	ST	Timer0 clock input.
	SEG14	x	O	ANA	LCD Segment 14 output; disables all other pin functions.
RA5/AN4/SEG15	RA5	0	O	DIG	LATA<5> data output; not affected by analog input.
		1	I	TTL	PORTA<5> data input; disabled when analog input is enabled.
	AN4	1	I	ANA	A/D Input Channel 4. Default configuration on POR.
	SEG15	x	O	ANA	LCD Segment 15 output; disables all other pin functions.
OSC2/CLKO/RA6	OSC2	x	O	ANA	Main oscillator feedback output connection (HS and HSPLL modes).
	CLKO	x	O	DIG	System cycle clock output ( $F_{OSC}/4$ ) (EC and ECPLL modes).
	RA6	0	O	DIG	LATA<6> data output; disabled when FOSC2 Configuration bit is set.
		1	I	TTL	PORTA<6> data input; disabled when FOSC2 Configuration bit is set.
OSC1/CLKI/RA7	OSC1	x	I	ANA	Main oscillator input connection (HS and HSPLL modes).
	CLKI	x	I	ANA	Main external clock source input (EC and ECPLL modes).
	RA7	0	O	DIG	LATA<7> data output; disabled when FOSC2 Configuration bit is set.
		1	I	TTL	PORTA<7> data input; disabled when FOSC2 Configuration bit is set.

Legend: O = Output, I = Input, ANA = Analog Signal, DIG = Digital Output, ST = Schmitt Trigger Buffer Input, TTL = TTL Buffer Input, x = Don't care (TRIS bit does not affect port direction or is overridden for this option).

# PIC18F87J72

---

**TABLE 10-4: SUMMARY OF REGISTERS ASSOCIATED WITH PORTA**

Name	Bit 7	Bit 6	Bit 5	Bit 4	Bit 3	Bit 2	Bit 1	Bit 0	Reset Values on page
PORTA	RA7 <sup>(1)</sup>	RA6 <sup>(1)</sup>	RA5	RA4	RA3	RA2	RA1	RA0	<a href="#">48</a>
LATA	LATA7 <sup>(1)</sup>	LATA6 <sup>(1)</sup>	LATA5	LATA4	LATA3	LATA2	LATA1	LATA0	<a href="#">48</a>
TRISA	TRISA7 <sup>(1)</sup>	TRISA6 <sup>(1)</sup>	TRISA5	TRISA4	TRISA3	TRISA2	TRISA1	TRISA0	<a href="#">48</a>
ADCON1	TRIGSEL	—	VCFG1	VCFG0	PCFG3	PCFG2	PCFG1	PCFG0	<a href="#">47</a>
LCDSE1	SE15	SE14	SE13	SE12	SE11	SE10	SE09	SE08	<a href="#">47</a>
LCDSE2	SE23	SE22	SE21	SE20	SE19	SE18	SE17	SE16	<a href="#">47</a>

Legend: — = unimplemented, read as '0'. Shaded cells are not used by PORTA.

**Note 1:** These bits are enabled depending on the oscillator mode selected. When not enabled as PORTA pins, they are disabled and read as 'x'.



## 10.3 PORTB, TRISB and LATB Registers

PORTB is an 8-bit wide, bidirectional port. The corresponding Data Direction and Output Latch registers are TRISB and LATB. All pins on PORTB are digital only and tolerate voltages up to 5.5V.

### EXAMPLE 10-2: INITIALIZING PORTB

```

CLRF   PORTB   ; Initialize PORTB by
           ; clearing output
           ; data latches
CLRF   LATB    ; Alternate method
           ; to clear output
           ; data latches
MOVLW  0CFh   ; Value used to
           ; initialize data
           ; direction
MOVWF  TRISB  ; Set RB<3:0> as inputs
           ; RB<5:4> as outputs
           ; RB<7:6> as inputs
    
```

Each of the PORTB pins has a weak internal pull-up. A single control bit can turn on all the pull-ups. This is performed by clearing bit,  $\overline{\text{RBPU}}$  (INTCON2<7>). The weak pull-up is automatically turned off when the port pin is configured as an output. The pull-ups are disabled on a Power-on Reset.

Four of the PORTB pins (RB<7:4>) have an interrupt-on-change feature. Only pins configured as inputs can cause this interrupt to occur (i.e., any RB<7:4> pin configured as an output is excluded from the interrupt-on-change comparison). The input pins (of RB<7:4>) are compared with the old value latched on the last read of PORTB. The “mismatch” outputs of RB<7:4> are ORed together to generate the RB Port Change Interrupt with Flag bit, RBIF (INTCON<0>).

This interrupt can wake the device from power-managed modes. The user, in the Interrupt Service Routine, can clear the interrupt in the following manner:

- a) Any read or write of PORTB (except with the MOVFF (ANY), PORTB instruction). This will end the mismatch condition.
- b) Wait one instruction cycle.
- c) Clear flag bit, RBIF.

A mismatch condition will continue to set flag bit, RBIF. Reading PORTB will end the mismatch condition and allow flag bit, RBIF, to be cleared after a delay of one TCY.

The interrupt-on-change feature is recommended for wake-up on key depression operation and operations where PORTB is only used for the interrupt-on-change feature. Polling of PORTB is not recommended while using the interrupt-on-change feature.

RB<3:2> are multiplexed as CTMU edge inputs.

RB<5:0> are also multiplexed with LCD segment drives, controlled by bits in the LCDSE1 and LCDSE3 registers. I/O port functionality is only available when the LCD segments are disabled.

# PIC18F87J72

**TABLE 10-5: PORTB FUNCTIONS**

Pin Name	Function	TRIS Setting	I/O	I/O Type	Description
RB0/INT0/SEG30	RB0	0	O	DIG	LATB<0> data output.
		1	I	TTL	PORTB<0> data input; weak pull-up when $\overline{\text{RBPU}}$ bit is cleared.
	INT0	1	I	ST	External Interrupt 0 input.
	SEG30	x	O	ANA	LCD Segment 30 output; disables all other pin functions.
RB1/INT1/SEG8	RB1	0	O	DIG	LATB<1> data output.
		1	I	TTL	PORTB<1> data input; weak pull-up when $\overline{\text{RBPU}}$ bit is cleared.
	INT1	1	I	ST	External Interrupt 1 input.
	SEG8	x	O	ANA	LCD Segment 8 output; disables all other pin functions.
RB2/INT2/SEG9/CTED1	RB2	0	O	DIG	LATB<2> data output.
		1	I	TTL	PORTB<2> data input; weak pull-up when $\overline{\text{RBPU}}$ bit is cleared.
	INT2	1	I	ST	External Interrupt 2 input.
	SEG9	x	O	ANA	LCD Segment 9 output; disables all other pin functions.
	CTED1	x	I	ST	CTMU Edge 1 input.
RB3/INT3/SEG10/CTED2	RB3	0	O	DIG	LATB<3> data output.
		1	I	TTL	PORTB<3> data input; weak pull-up when $\overline{\text{RBPU}}$ bit is cleared.
	INT3	1	I	ST	External Interrupt 3 input.
	SEG10	x	O	ANA	LCD Segment 10 output; disables all other pin functions.
	CTED2	x	I	ST	CTMU Edge 2 input.
RB4/KBI0/SEG11	RB4	0	O	DIG	LATB<4> data output.
		1	I	TTL	PORTB<4> data input; weak pull-up when $\overline{\text{RBPU}}$ bit is cleared.
	KBI0	1	I	TTL	Interrupt-on-pin change.
	SEG11	x	O	ANA	LCD Segment 11 output; disables all other pin functions.
RB5/KBI1/SEG29	RB5	0	O	DIG	LATB<5> data output.
		1	I	TTL	PORTB<5> data input; weak pull-up when $\overline{\text{RBPU}}$ bit is cleared.
	KBI1	1	I	TTL	Interrupt-on-pin change.
	SEG29	x	O	ANA	LCD Segment 29 output; disables all other pin functions.
RB6/KBI2/PGC	RB6	0	O	DIG	LATB<6> data output.
		1	I	TTL	PORTB<6> data input; weak pull-up when $\overline{\text{RBPU}}$ bit is cleared.
	KBI2	1	I	TTL	Interrupt-on-pin change.
	PGC	x	I	ST	Serial execution (ICSP™) clock input for ICSP and ICD operation.
RB7/KBI3/PGD	RB7	0	O	DIG	LATB<7> data output.
		1	I	TTL	PORTB<7> data input; weak pull-up when $\overline{\text{RBPU}}$ bit is cleared.
	KBI3	1	I	TTL	Interrupt-on-pin change.
	PGD	x	O	DIG	Serial execution data output for ICSP™ and ICD operation.
		x	I	ST	Serial execution data input for ICSP and ICD operation.

Legend: O = Output, I = Input, ANA = Analog Signal, DIG = Digital Output, ST = Schmitt Trigger Buffer Input, TTL = TTL Buffer Input, x = Don't care (TRIS bit does not affect port direction or is overridden for this option).

**TABLE 10-6: SUMMARY OF REGISTERS ASSOCIATED WITH PORTB**

Name	Bit 7	Bit 6	Bit 5	Bit 4	Bit 3	Bit 2	Bit 1	Bit 0	Reset Values on page
PORTB	RB7	RB6	RB5	RB4	RB3	RB2	RB1	RB0	48
LATB	LATB7	LATB6	LATB5	LATB4	LATB3	LATB2	LATB1	LATB0	48
TRISB	TRISB7	TRISB6	TRISB5	TRISB4	TRISB3	TRISB2	TRISB1	TRISB0	48
INTCON	GIE/GIEH	PEIE/GIEL	TMR0IE	INT0IE	RBIE	TMR0IF	INT0IF	RBIF	45
INTCON2	RBP $\overline{U}$	INTEDG0	INTEDG1	INTEDG2	INTEDG3	TMR0IP	INT3IP	RBIP	45
INTCON3	INT2IP	INT1IP	INT3IE	INT2IE	INT1IE	INT3IF	INT2IF	INT1IF	45
LCDSE1	SE15	SE14	SE13	SE12	SE11	SE10	SE09	SE08	47
LCDSE3	SE31	SE30	SE29	SE28	SE27	SE26	SE25	SE24	47

Legend: Shaded cells are not used by PORTB.

# PIC18F87J72

## 10.4 PORTC, TRISC and LATC Registers

PORTC is an 8-bit wide, bidirectional port. The corresponding Data Direction and Output Latch registers are TRISC and LATC. Only PORTC pins, RC2 through RC7, are digital only pins and can tolerate input voltages up to 5.5V.

PORTC is multiplexed with CCP, MSSP and EUSART peripheral functions (Table 10-7). The pins have Schmitt Trigger input buffers. The pins for CCP, SPI and EUSART are also configurable for open-drain output whenever these functions are active. Open-drain configuration is selected by setting the SPIOD, CCPxOD, and U1OD control bits (TRISG<7:5> and LATG<6>, respectively).

RC1 is normally configured as the default peripheral pin for the CCP2 module. Assignment of CCP2 is controlled by Configuration bit, CCP2MX (default state, CCP2MX = 1).

When enabling peripheral functions, care should be taken in defining TRIS bits for each PORTC pin. Some peripherals override the TRIS bit to make a pin an output, while other peripherals override the TRIS bit to make a pin an input. The user should refer to the corresponding peripheral section for the correct TRIS bit settings.

**Note:** These pins are configured as digital inputs on any device Reset.

The contents of the TRISC register are affected by peripheral overrides. Reading TRISC always returns the current contents, even though a peripheral device may be overriding one or more of the pins.

RC<7:1> pins are multiplexed with LCD segment drives, controlled by bits in the LCDSE1, LCDSE2, LCDSE3 and LCDSE4 registers. I/O port functionality is only available when the LCD segments are disabled.

### EXAMPLE 10-3: INITIALIZING PORTC

```
CLRF   PORTC   ; Initialize PORTC by
           ; clearing output
           ; data latches
CLRF   LATC    ; Alternate method
           ; to clear output
           ; data latches
MOVLW  0CFh   ; Value used to
           ; initialize data
           ; direction
MOVWF  TRISC   ; Set RC<3:0> as inputs
           ; RC<5:4> as outputs
           ; RC<7:6> as inputs
```

**TABLE 10-7: PORTC FUNCTIONS**

Pin Name	Function	TRIS Setting	I/O	I/O Type	Description
RC0/T1OSO/ T13CKI	RC0	0	O	DIG	LATC<0> data output.
		1	I	ST	PORTC<0> data input.
	T1OSO	x	O	ANA	Timer1 oscillator output; enabled when Timer1 oscillator is enabled. Disables digital I/O and LCD segment driver.
	T13CKI	1	I	ST	Timer1/Timer3 counter input.
RC1/T1OSI/ CCP2/SEG32	RC1	0	O	DIG	LATC<1> data output.
		1	I	ST	PORTC<1> data input.
	T1OSI	x	I	ANA	Timer1 oscillator input.
	CCP2 <sup>(1)</sup>	0	O	DIG	CCP2 Compare/PWM output.
		1	I	ST	CCP2 Capture input.
SEG32	x	O	ANA	LCD Segment 32 output; disables all other pin functions.	
RC2/CCP1/ SEG13	RC2	0	O	DIG	LATC<2> data output.
		1	I	ST	PORTC<2> data input.
	CCP1	0	O	DIG	CCP1 Compare/PWM output; takes priority over port data.
		1	I	ST	CCP1 Capture input.
	SEG13	x	O	ANA	LCD Segment 13 output; disables all other pin functions.
RC3/SCK/SCL/ SEG17	RC3	0	O	DIG	LATC<3> data output.
		1	I	ST	PORTC<3> data input.
	SCK	0	O	DIG	SPI clock output (MSSP module); takes priority over port data.
		1	I	ST	SPI clock input (MSSP module).
	SCL	0	O	DIG	I <sup>2</sup> C clock output (MSSP module); takes priority over port data.
		1	I	I <sup>2</sup> C	I <sup>2</sup> C clock input (MSSP module); input type depends on module setting.
	SEG17	x	O	ANA	LCD Segment 17 output; disables all other pin functions.
RC4/SDI/SDA/ SEG16	RC4	0	O	DIG	LATC<4> data output.
		1	I	ST	PORTC<4> data input.
	SDI		I	ST	SPI data input (MSSP module).
	SDA	1	O	DIG	I <sup>2</sup> C data output (MSSP module); takes priority over port data.
		1	I	I <sup>2</sup> C	I <sup>2</sup> C data input (MSSP module); input type depends on module setting.
SEG16	x	O	ANA	LCD Segment 16 output; disables all other pin functions.	
RC5/SDO/ SEG12	RC5	0	O	DIG	LATC<5> data output.
		1	I	ST	PORTC<5> data input.
	SDO	0	O	DIG	SPI data output (MSSP module).
	SEG12	x	O	ANA	LCD Segment 12 output; disables all other pin functions.
RC6/TX1/CK1/ SEG27	RC6	0	O	DIG	LATC<6> data output.
		1	I	ST	PORTC<6> data input.
	TX1	1	O	DIG	Synchronous serial data output (EUSART module); takes priority over port data.
	CK1	1	O	DIG	Synchronous serial data input (EUSART module); user must configure as an input.
		1	I	ST	Synchronous serial clock input (EUSART module).
SEG27	x	O	ANA	LCD Segment 27 output; disables all other pin functions.	

Legend: O = Output, I = Input, ANA = Analog Signal, DIG = Digital Output, ST = Schmitt Trigger Buffer Input, TTL = TTL Buffer Input, I<sup>2</sup>C = I<sup>2</sup>C/SMBus Buffer Input, x = Don't care (TRIS bit does not affect port direction or is overridden for this option).

**Note 1:** Default assignment for CCP2 when CCP2MX Configuration bit is set.

# PIC18F87J72

**TABLE 10-7: PORTC FUNCTIONS (CONTINUED)**

Pin Name	Function	TRIS Setting	I/O	I/O Type	Description
RC7/RX1/DT1/ SEG28	RC7	0	O	DIG	LATC<7> data output.
		1	I	ST	PORTC<7> data input.
	RX1	1	I	ST	Asynchronous serial receive data input (EUSART module).
	DT1	1	O	DIG	Synchronous serial data output (EUSART module); takes priority over port data.
		1	I	ST	Synchronous serial data input (EUSART module); user must configure as an input.
	SEG28	x	O	ANA	LCD Segment 28 output; disables all other pin functions.

Legend: O = Output, I = Input, ANA = Analog Signal, DIG = Digital Output, ST = Schmitt Trigger Buffer Input, TTL = TTL Buffer Input, I<sup>2</sup>C = I<sup>2</sup>C/SMBus Buffer Input, x = Don't care (TRIS bit does not affect port direction or is overridden for this option).

**Note 1:** Default assignment for CCP2 when CCP2MX Configuration bit is set.

**TABLE 10-8: SUMMARY OF REGISTERS ASSOCIATED WITH PORTC**

Name	Bit 7	Bit 6	Bit 5	Bit 4	Bit 3	Bit 2	Bit 1	Bit 0	Reset Values on page
PORTC	RC7	RC6	RC5	RC4	RC3	RC2	RC1	RC0	48
LATC	LATC7	LATBC6	LATC5	LATCB4	LATC3	LATC2	LATC1	LATC0	48
TRISC	TRISC7	TRISC6	TRISC5	TRISC4	TRISC3	TRISC2	TRISC1	TRISC0	48
LATG	U2OD	U1OD	—	LATG4	LATG3	LATG2	LATG1	LATG0	48
TRISG	SPIOD	CCP2OD	CCP1OD	TRISG4	TRISG3	TRISG2	TRISG1	TRISG0	48
LCDSE1	SE15	SE14	SE13	SE12	SE11	SE10	SE09	SE08	47
LCDSE2	SE23	SE22	SE21	SE20	SE19	SE18	SE17	SE16	47
LCDSE3	SE31	SE30	SE29	SE28	SE27	SE26	SE25	SE24	47
LCDSE4	—	—	—	—	—	—	—	SE32	47

Legend: Shaded cells are not used by PORTC.

## 10.5 PORTD, TRISD and LATD Registers

PORTD is an 8-bit wide, bidirectional port. The corresponding Data Direction and Output Latch registers are TRISD and LATD. All pins on PORTD are digital only and tolerate voltages up to 5.5V.

All pins on PORTD are implemented with Schmitt Trigger input buffers. Each pin is individually configurable as an input or output.

**Note:** These pins are configured as digital inputs on any device Reset.

Each of the PORTD pins has a weak internal pull-up. A single control bit can turn off all the pull-ups. This is performed by clearing bit, RDPU (PORTG<7>). The weak pull-up is automatically turned off when the port pin is configured as an output. The pull-ups are disabled on all device Resets.

All of the PORTD pins are multiplexed with LCD segment drives, controlled by bits in the LCDSE0 register. RD0 is multiplexed with the CTMU Pulse Generator output.

I/O port functionality is only available when the LCD segments are disabled.

### EXAMPLE 10-4: INITIALIZING PORTD

```
CLRF    PORTD    ; Initialize PORTD by
                ; clearing output
                ; data latches
CLRF    LATD     ; Alternate method
                ; to clear output
                ; data latches
MOVLW   0CFh    ; Value used to
                ; initialize data
                ; direction
MOVWF   TRISD   ; Set RD<3:0> as inputs
                ; RD<5:4> as outputs
                ; RD<7:6> as inputs
```

# PIC18F87J72

**TABLE 10-9: PORTD FUNCTIONS**

Pin Name	Function	TRIS Setting	I/O	I/O Type	Description
RD0/SEG0/ CTPLS	RD0	0	O	DIG	LATD<0> data output.
		1	I	ST	PORTD<0> data input.
	SEG0	x	O	ANA	LCD Segment 0 output; disables all other pin functions.
	CTPLS	x	O	DIG	CTMU Pulse Generator output
RD1/SEG1	RD1	0	O	DIG	LATD<1> data output.
		1	I	ST	PORTD<1> data input.
	SEG1	x	O	ANA	LCD Segment 1 output; disables all other pin functions.
RD2/SEG2	RD2	0	O	DIG	LATD<2> data output.
		1	I	ST	PORTD<2> data input.
	SEG2	x	O	ANA	LCD Segment 2 output; disables all other pin functions.
RD3/SEG3	RD3	0	O	DIG	LATD<3> data output.
		1	I	ST	PORTD<3> data input.
	SEG3	x	O	ANA	LCD Segment 3 output; disables all other pin functions.
RD4/SEG4	RD4	0	O	DIG	LATD<4> data output.
		1	I	ST	PORTD<4> data input.
	SEG4	x	O	ANA	LCD Segment 4 output; disables all other pin functions.
RD5/SEG5	RD5	0	O	DIG	LATD<5> data output.
		1	I	ST	PORTD<5> data input.
	SEG5	x	O	ANA	LCD Segment 5 output; disables all other pin functions.
RD6/SEG6	RD6	0	O	DIG	LATD<6> data output.
		1	I	ST	PORTD<6> data input.
	SEG6	x	O	ANA	LCD Segment 6 output; disables all other pin functions.
RD7/SEG7	RD7	0	O	DIG	LATD<7> data output.
		1	I	ST	PORTD<7> data input.
	SEG7	x	I	ANA	LCD Segment 7 output; disables all other pin functions.

Legend: O = Output, I = Input, ANA = Analog Signal, DIG = Digital Output, ST = Schmitt Trigger Buffer Input, x = Don't care (TRIS bit does not affect port direction or is overridden for this option).

**TABLE 10-10: SUMMARY OF REGISTERS ASSOCIATED WITH PORTD**

Name	Bit 7	Bit 6	Bit 5	Bit 4	Bit 3	Bit 2	Bit 1	Bit 0	Reset Values on page
PORTD	RD7	RD6	RD5	RD4	RD3	RD2	RD1	RD0	48
LATD	LATD7	LATD6	LATD5	LATD4	LATD3	LATD2	LATD1	LATD0	48
TRISD	TRISD7	TRISD6	TRISD5	TRISD4	TRISD3	TRISD2	TRISD1	TRISD0	48
PORTG	RDPUP	REPU	RJPU	RG4	RG3	RG2	RG1	RG0	48
LCDSE0	SE07	SE06	SE05	SE04	SE03	SE02	SE01	SE00	47

Legend: Shaded cells are not used by PORTD.



## 10.6 PORTE, TRISE and LATE Registers

PORTE is a 7-bit wide, bidirectional port. The corresponding Data Direction and Output Latch registers are TRISE and LATE. All pins on PORTE are digital only and tolerate voltages up to 5.5V.

All pins on PORTE are implemented with Schmitt Trigger input buffers. Each pin is individually configurable as an input or output. The RE7 pin is also configurable for open-drain output when CCP2 is active on this pin. Open-drain configuration is selected by setting the CCP2OD control bit (TRISG<6>)

**Note:** These pins are configured as digital inputs on any device Reset.

Each of the PORTE pins has a weak internal pull-up. A single control bit can turn off all the pull-ups. This is performed by clearing bit, REPU (PORTG<6>). The weak pull-up is automatically turned off when the port pin is configured as an output. The pull-ups are disabled on any device Reset.

Pins, RE<6:3>, are multiplexed with the LCD common drives. I/O port functions are only available on those PORTE pins depending on which commons are active. The configuration is determined by the LMUX<1:0> control bits (LCDCON<1:0>). The availability is summarized in [Table 10-11](#).

Pins, RE1 and RE0, are multiplexed with the functions of LCDBIAS2 and LCDBIAS1. When LCD bias generation is required (i.e., any application where the device is connected to an external LCD), these pins cannot be used as digital I/O.

**Note:** The pin corresponding to RE2 of other PIC18F parts has the function of LCDBIAS3 in this device. It cannot be used as digital I/O.

RE7 is multiplexed with the LCD segment drive (SEG31) controlled by the LCDSE3<7> bit. I/O port function is only available when the segment is disabled.

RE7 can also be configured as the alternate peripheral pin for the CCP2 module. This is done by clearing the CCP2MX Configuration bit.

### EXAMPLE 10-5: INITIALIZING PORTE

```

CLRFB   PORTE   ; Initialize PORTE by
           ; clearing output
           ; data latches
CLRFB   LATE    ; Alternate method
           ; to clear output
           ; data latches
MOVLW   03h    ; Value used to
           ; initialize data
           ; direction
MOVWF   TRISE  ; Set RE<1:0> as inputs
           ; RE<7:2> as outputs
    
```

**TABLE 10-11: PORTE PINS AVAILABLE IN DIFFERENT LCD DRIVE CONFIGURATIONS**

LCDCON <1:0>	Active LCD Commons	PORTE Available for I/O
00	COM0	RE6, RE5, RE4
01	COM0, COM1	RE6, RE5
10	COM0, COM1 and COM2	RE6
11	All (COM0 through COM3)	None

# PIC18F87J72

**TABLE 10-12: PORTE FUNCTIONS**

Pin Name	Function	TRIS Setting	I/O	I/O Type	Description
RE0/LCDBIAS1	RE0	0	O	DIG	LATE<0> data output.
		1	I	ST	PORTE<0> data input.
	LCDBIAS1	—	I	ANA	LCD module bias voltage input.
RE1/LCDBIAS2	RE1	0	O	DIG	LATE<1> data output.
		1	I	ST	PORTE<1> data input.
	LCDBIAS2	—	I	ANA	LCD module bias voltage input.
RE3/COM0	RE3	0	O	DIG	LATE<3> data output.
		1	I	ST	PORTE<3> data input.
	COM0	x	O	ANA	LCD Common 0 output; disables all other outputs.
RE4/COM1	RE4	0	O	DIG	LATE<4> data output.
		1	I	ST	PORTE<4> data input.
	COM1	x	O	ANA	LCD Common 1 output; disables all other outputs.
RE5/COM2	RE5	0	O	DIG	LATE<5> data output.
		1	I	ST	PORTE<5> data input.
	COM2	x	O	ANA	LCD Common 2 output; disables all other outputs.
RE6/COM3	RE6	0	O	DIG	LATE<6> data output.
		1	I	ST	PORTE<6> data input.
	COM3	x	O	ANA	LCD Common 3 output; disables all other outputs.
RE7/CCP2/ SEG31	RE7	0	O	DIG	LATE<7> data output.
		1	I	ST	PORTE<7> data input.
	CCP2 <sup>(1)</sup>	0	O	DIG	CCP2 Compare/PWM output; takes priority over port data.
		1	I	ST	CCP2 Capture input.
	SEG31	x	O	ANA	Segment 31 analog output for LCD; disables digital output.

Legend: O = Output, I = Input, ANA = Analog Signal, DIG = Digital Output, ST = Schmitt Trigger Buffer Input,  
x = Don't care (TRIS bit does not affect port direction or is overridden for this option).

**Note 1:** Alternate assignment for CCP2 when CCP2MX Configuration bit is cleared.

**TABLE 10-13: SUMMARY OF REGISTERS ASSOCIATED WITH PORTE**

Name	Bit 7	Bit 6	Bit 5	Bit 4	Bit 3	Bit 2	Bit 1	Bit 0	Reset Values on page
PORTE	RE7	RE6	RE5	RE4	RE3	—	RE1	RE0	48
LATE	LATE7	LATE6	LATE5	LATE4	LATE3	—	LATE1	LATE0	48
TRISE	TRISE7	TRISE6	TRISE5	TRISE4	TRISE3	—	TRISE1	TRISE0	48
PORTG	RDPU	REPU	RJPU	RG4	RG3	RG2	RG1	RG0	48
TRISG	SPIOD	CCP2OD	CCP1OD	TRISG4	TRISG3	TRISG2	TRISG1	TRISG0	48
LCDCON	LCDEN	SLPEN	WERR	—	CS1	CS0	LMUX1	LMUX0	47
LCDSE3	SE31	SE30	SE29	SE28	SE27	SE26	SE25	SE24	47

Legend: Shaded cells are not used by PORTE.

## 10.7 PORTF, LATF and TRISF Registers

PORTF is a 7-bit wide, bidirectional port. The corresponding Data Direction and Output Latch registers are TRISF and LATF. All pins on PORTF are implemented with Schmitt Trigger input buffers. Each pin is individually configurable as an input or output.

PORTF is multiplexed with analog peripheral functions, as well as LCD segments. Pins, RF1 through RF6, may be used as comparator inputs or outputs by setting the appropriate bits in the CMCON register. To use RF<6:3> as digital inputs, it is also necessary to turn off the comparators.

**Note 1:** On device Resets, pins, RF<6:1>, are configured as analog inputs and are read as '0'.

**2:** To configure PORTF as digital I/O, turn off comparators and set ADCON1 value.

PORTF is also multiplexed with LCD segment drives controlled by bits in the LCDSE2 and LCDSE3 registers. I/O port functions are only available when the segments are disabled.

### EXAMPLE 10-6: INITIALIZING PORTF

```
CLRF    PORTF    ; Initialize PORTF by
                ; clearing output
                ; data latches
CLRF    LATF     ; Alternate method
                ; to clear output
                ; data latches
MOVLW   07h     ;
MOVWF   CMCON   ; Turn off comparators
MOVLW   0Fh     ;
MOVWF   ADCON1  ; Set PORTF as digital I/O
MOVLW   0CEh   ; Value used to
                ; initialize data
                ; direction
MOVWF   TRISF   ; Set RF3:RF1 as inputs
                ; RF5:RF4 as outputs
                ; RF7:RF6 as inputs
```

# PIC18F87J72

**TABLE 10-14: PORTF FUNCTIONS**

Pin Name	Function	TRIS Setting	I/O	I/O Type	Description
RF1/AN6/C2OUT/SEG19	RF1	0	O	DIG	LATF<1> data output; not affected by analog input.
		1	I	ST	PORTF<1> data input; disabled when analog input is enabled.
	AN6	1	I	ANA	A/D Input Channel 6. Default configuration on POR.
	C2OUT	0	O	DIG	Comparator 2 output; takes priority over port data.
	SEG19	x	O	ANA	LCD Segment 19 output; disables all other pin functions.
RF2/AN7/C1OUT/SEG20	RF2	0	O	DIG	LATF<2> data output; not affected by analog input.
		1	I	ST	PORTF<2> data input; disabled when analog input is enabled.
	AN7	1	I	ANA	A/D Input Channel 7. Default configuration on POR.
	C1OUT	0	O	DIG	Comparator 1 output; takes priority over port data.
	SEG20	x	O	ANA	LCD Segment 20 output; disables all other pin functions.
RF3/AN8/SEG21/C2INB	RF3	0	O	DIG	LATF<3> data output; not affected by analog input.
		1	I	ST	PORTF<3> data input; disabled when analog input is enabled.
	AN8	1	I	ANA	A/D Input Channel 8 and Comparator C2+ input. Default input configuration on POR; not affected by analog output.
	SEG21	x	O	ANA	LCD Segment 21 output; disables all other pin functions.
	C2INB	1	I	ANA	Comparator 2 Input B.
RF4/AN9/SEG22/C2INA	RF4	0	O	DIG	LATF<4> data output; not affected by analog input.
		1	I	ST	PORTF<4> data input; disabled when analog input is enabled.
	AN9	1	I	ANA	A/D Input Channel 9 and Comparator C2- input. Default input configuration on POR; does not affect digital output.
	SEG22	x	O	ANA	LCD Segment 22 output; disables all other pin functions.
	C2INA	1	I	ANA	Comparator 2 Input A.
RF5/AN10/CVREF/SEG23/C1INB	RF5	0	O	DIG	LATF<5> data output; not affected by analog input. Disabled when CVREF output is enabled.
		1	I	ST	PORTF<5> data input; disabled when analog input is enabled. Disabled when CVREF output is enabled.
	AN10	1	I	ANA	A/D Input Channel 10 and Comparator C1+ input. Default input configuration on POR.
	CVREF	x	O	ANA	Comparator voltage reference output. Enabling this feature disables digital I/O.
	SEG23	x	O	ANA	LCD Segment 23 output; disables all other pin functions.
	C1INB	1	I	ANA	Comparator 1 Input B.
RF6/AN11/SEG24/C1INA	RF6	0	O	DIG	LATF<6> data output; not affected by analog input.
		1	I	ST	PORTF<6> data input; disabled when analog input is enabled.
	AN11	1	I	ANA	A/D Input Channel 11 and Comparator C1- input. Default input configuration on POR; does not affect digital output.
	SEG24	x	O	ANA	LCD Segment 24 output; disables all other pin functions.
	C1INA	1	I	ANA	Comparator 1 Input A.
RF7/AN5/SS/SEG25	RF7	0	O	DIG	LATF<7> data output; not affected by analog input.
		1	I	ST	PORTF<7> data input; disabled when analog input is enabled.
	AN5	1	I	ANA	A/D Input Channel 5. Default configuration on POR.
	SS	1	I	TTL	Slave select input for MSSP module.
	SEG25	x	O	ANA	LCD Segment 25 output; disables all other pin functions.

Legend: O = Output, I = Input, ANA = Analog Signal, DIG = Digital Output, ST = Schmitt Trigger Buffer Input, TTL = TTL Buffer Input, x = Don't care (TRIS bit does not affect port direction or is overridden for this option).

**TABLE 10-15: SUMMARY OF REGISTERS ASSOCIATED WITH PORTF**

Name	Bit 7	Bit 6	Bit 5	Bit 4	Bit 3	Bit 2	Bit 1	Bit 0	Reset Values on page
PORTF	RF7	RF6	RF5	RF4	RF3	RF2	RF1	—	48
LATF	LATF7	LATF6	LATF5	LATF4	LATF3	LATF2	LATF1	—	48
TRISF	TRISF7	TRISF6	TRISF5	TRISF4	TRISF3	TRISF2	TRISF1	—	48
ADCON1	TRIGSEL	—	VCFG1	VCFG0	PCFG3	PCFG2	PCFG1	PCFG0	47
CMCON	C2OUT	C1OUT	C2INV	C1INV	CIS	CM2	CM1	CM0	47
CVRCON	CVREN	CVROE	CVRR	CVRSS	CVR3	CVR2	CVR1	CVR0	47
LCDSE2	SE23	SE22	SE21	SE20	SE19	SE18	SE17	SE16	47
LCDSE3	SE31	SE30	SE29	SE28	SE27	SE26	SE25	SE24	47

Legend: — = unimplemented, read as '0'. Shaded cells are not used by PORTF.

# PIC18F87J72

## 10.8 PORTG, TRISG and LATG Registers

PORTG is a 5-bit wide, bidirectional port. The corresponding Data Direction and Output Latch registers are TRISG and LATG. All pins on PORTG are digital only and tolerate voltages up to 5.5V.

PORTG is multiplexed with both AUSART and LCD functions (Table ). When operating as I/O, all PORTG pins have Schmitt Trigger input buffers. The RG1 pin is also configurable for open-drain output when the AUSART is active. Open-drain configuration is selected by setting the U2OD control bit (LATG<7>).

RG4 is multiplexed with LCD segment drives controlled by bits in the LCDSE2 register and as the RTCC pin. The I/O port function is only available when the segments are disabled.

RG3 and RG2 are multiplexed with VLCAP pins for the LCD charge pump and RG0 is multiplexed with the LCDBIAS0 bias voltage input. When these pins are used for LCD bias generation, the I/O and other functions are unavailable.

When enabling peripheral functions, care should be taken in defining TRIS bits for each PORTG pin. Some peripherals override the TRIS bit to make a pin an output, while other peripherals override the TRIS bit to make a pin an input. The user should refer to the corresponding peripheral section for the correct TRIS bit settings. The pin override value is not loaded into the TRIS register. This allows read-modify-write of the TRIS register without concern due to peripheral overrides.

Although the port itself is only five bits wide, the PORTG<7:5> bits are still implemented to control the weak pull-ups on the I/O ports associated with PORTD, PORTE and PORTJ. Clearing these bits enables the respective port pull-ups. By default, all pull-ups are disabled on device Resets.

Most of the corresponding TRISG and LATG bits are implemented as open-drain control bits for CCP1, CCP2 and SPI (TRISG<7:5>), and the USARTs (LATG<7:6>). Setting these bits configures the output pin for the corresponding peripheral for open-drain operation. LATG<5> is not implemented.

### EXAMPLE 10-7: INITIALIZING PORTG

```
CLRF    PORTG    ; Initialize PORTG by
           ; clearing output
           ; data latches
CLRF    LATG     ; Alternate method
           ; to clear output
           ; data latches
MOVLW   04h     ; Value used to
           ; initialize data
           ; direction
MOVWF   TRISG   ; Set RG1:RG0 as outputs
           ; RG2 as input
           ; RG4:RG3 as inputs
```

**TABLE 10-16: PORTG FUNCTIONS**

Pin Name	Function	TRIS Setting	I/O	I/O Type	Description
RG0/LCDBIAS0	RG0	0	O	DIG	LATG<0> data output.
		1	I	ST	PORTG<0> data input.
	LCDBIAS0	x	I	ANA	LCD module bias voltage input.
RG1/TX2/CK2	RG1	0	O	DIG	LATG<1> data output.
		1	I	ST	PORTG<1> data input.
	TX2	1	O	DIG	Synchronous serial data output (AUSART module); takes priority over port data.
	CK2	1	O	DIG	Synchronous serial data input (AUSART module); user must configure as an input.
1		I	ST	Synchronous serial clock input (AUSART module).	
RG2/RX2/DT2/VLCAP1	RG2	0	O	DIG	LATG<2> data output.
		1	I	ST	PORTG<2> data input.
	RX2	1	I	ST	Asynchronous serial receive data input (AUSART module).
	DT2	1	O	DIG	Synchronous serial data output (AUSART module); takes priority over port data.
		1	I	ST	Synchronous serial data input (AUSART module); user must configure as an input.
VLCAP1	x	I	ANA	LCD charge pump capacitor input.	
RG3/VLCAP2	RG3	0	O	DIG	LATG<3> data output.
		1	I	ST	PORTG<3> data input.
	VLCAP2	x	I	ANA	LCD charge pump capacitor input.
RG4/SEG26/RTCC	RG4	0	O	DIG	LATG<4> data output.
		1	I	ST	PORTG<4> data input.
	SEG26	x	O	ANA	LCD Segment 26 output; disables all other pin functions.
	RTCC	x	O	DIG	RTCC output.

Legend: O = Output, I = Input, ANA = Analog Signal, DIG = Digital Output, ST = Schmitt Trigger Buffer Input, x = Don't care (TRIS bit does not affect port direction or is overridden for this option).

**TABLE 10-17: SUMMARY OF REGISTERS ASSOCIATED WITH PORTG**

Name	Bit 7	Bit 6	Bit 5	Bit 4	Bit 3	Bit 2	Bit 1	Bit 0	Reset Values on page
PORTG	RDPU	REPU	RJPU	RG4	RG3	RG2	RG1	RG0	48
LATG	U2OD	U1OD	—	LATG4	LATG3	LATG2	LATG1	LATG0	48
TRISG	SPIOD	CCP2OD	CCP1OD	TRISG4	TRISG3	TRISG2	TRISG1	TRISG0	48
LCDSE3	SE31	SE30	SE29	SE28	SE27	SE26	SE25	SE24	47

Legend: — = unimplemented, read as '0'. Shaded cells are not used by PORTG.

# PIC18F87J72

## 11.0 TIMER0 MODULE

The Timer0 module incorporates the following features:

- Software selectable operation as a timer or counter in both 8-bit or 16-bit modes
- Readable and writable registers
- Dedicated 8-bit, software programmable prescaler
- Selectable clock source (internal or external)
- Edge select for external clock
- Interrupt-on-overflow

The T0CON register ([Register 11-1](#)) controls all aspects of the module's operation, including the prescale selection; it is both readable and writable.

A simplified block diagram of the Timer0 module in 8-bit mode is shown in [Figure 11-1](#). [Figure 11-2](#) shows a simplified block diagram of the Timer0 module in 16-bit mode.

**REGISTER 11-1: T0CON: TIMER0 CONTROL REGISTER**

R/W-1	R/W-1	R/W-1	R/W-1	R/W-1	R/W-1	R/W-1	R/W-1
TMR0ON	T08BIT	T0CS	T0SE	PSA	T0PS2	T0PS1	T0PS0
bit 7							bit 0

Legend:

R = Readable bit

W = Writable bit

U = Unimplemented bit, read as '0'

-n = Value at POR

'1' = Bit is set

'0' = Bit is cleared

x = Bit is unknown

bit 7 **TMR0ON:** Timer0 On/Off Control bit

1 = Enables Timer0

0 = Stops Timer0

bit 6 **T08BIT:** Timer0 8-Bit/16-Bit Control bit

1 = Timer0 is configured as an 8-bit timer/counter

0 = Timer0 is configured as a 16-bit timer/counter

bit 5 **T0CS:** Timer0 Clock Source Select bit

1 = Transition on T0CKI pin input edge

0 = Internal clock (2/4)

bit 4 **T0SE:** Timer0 Source Edge Select bit

1 = Increment on high-to-low transition on T0CKI pin

0 = Increment on low-to-high transition on T0CKI pin

bit 3 **PSA:** Timer0 Prescaler Assignment bit

1 = Timer0 prescaler is not assigned. Timer0 clock input bypasses prescaler.

0 = Timer0 prescaler is assigned. Timer0 clock input comes from prescaler output.

bit 2-0 **T0PS<2:0>:** Timer0 Prescaler Select bits

111 = 1:256 Prescale value

110 = 1:128 Prescale value

101 = 1:64 Prescale value

100 = 1:32 Prescale value

011 = 1:16 Prescale value

010 = 1:8 Prescale value

001 = 1:4 Prescale value

000 = 1:2 Prescale value



## 11.1 Timer0 Operation

Timer0 can operate as either a timer or a counter. The mode is selected with the T0CS bit (T0CON<5>). In Timer mode (T0CS = 0), the module increments on every clock by default unless a different prescaler value is selected (see [Section 11.3 “Prescaler”](#)). If the TMR0 register is written to, the increment is inhibited for the following two instruction cycles. The user can work around this by writing an adjusted value to the TMR0 register.

The Counter mode is selected by setting the T0CS bit (= 1). In this mode, Timer0 increments either on every rising or falling edge of pin, RA4/T0CKI. The incrementing edge is determined by the Timer0 Source Edge Select bit, T0SE (T0CON<4>); clearing this bit selects the rising edge. Restrictions on the external clock input are discussed below.

An external clock source can be used to drive Timer0, however, it must meet certain requirements to ensure that the external clock can be synchronized with the

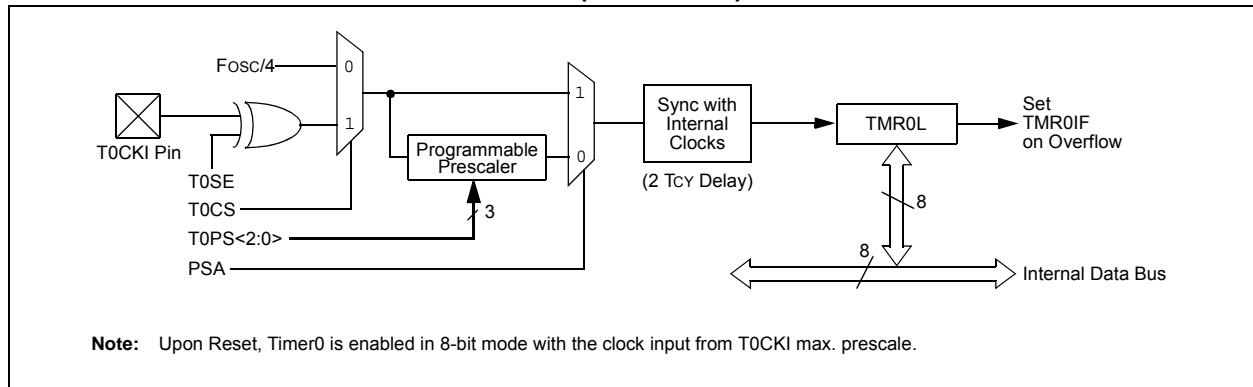
internal phase clock (Tosc). There is a delay between synchronization and the onset of incrementing the timer/counter.

## 11.2 Timer0 Reads and Writes in 16-Bit Mode

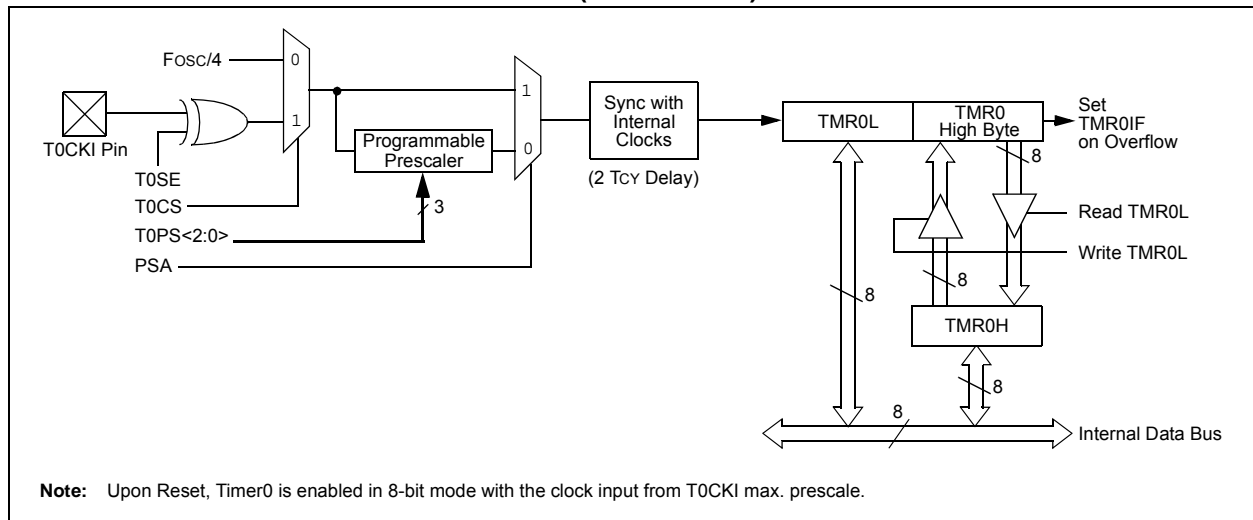
TMR0H is not the actual high byte of Timer0 in 16-bit mode. It is actually a buffered version of the real high byte of Timer0, which is not directly readable nor writable (refer to [Figure 11-2](#)). TMR0H is updated with the contents of the high byte of Timer0 during a read of TMR0L. This provides the ability to read all 16 bits of Timer0 without having to verify that the read of the high and low byte were valid, due to a rollover between successive reads of the high and low byte.

Similarly, a write to the high byte of Timer0 must also take place through the TMR0H Buffer register. The high byte is updated with the contents of TMR0H when a write occurs to TMR0L. This allows all 16 bits of Timer0 to be updated at once.

**FIGURE 11-1: TIMER0 BLOCK DIAGRAM (8-BIT MODE)**



**FIGURE 11-2: TIMER0 BLOCK DIAGRAM (16-BIT MODE)**



# PIC18F87J72

## 11.3 Prescaler

An 8-bit counter is available as a prescaler for the Timer0 module. The prescaler is not directly readable or writable. Its value is set by the PSA and T0PS<2:0> bits (T0CON<3:0>) which determine the prescaler assignment and prescale ratio.

Clearing the PSA bit assigns the prescaler to the Timer0 module. When it is assigned, prescale values from 1:2 through 1:256, in power-of-2 increments, are selectable.

When assigned to the Timer0 module, all instructions writing to the TMR0 register (e.g., CLRF TMR0, MOVWF TMR0, BSF TMR0, etc.) clear the prescaler count.

**Note:** Writing to TMR0 when the prescaler is assigned to Timer0 will clear the prescaler count but will not change the prescaler assignment.

### 11.3.1 SWITCHING PRESCALER ASSIGNMENT

The prescaler assignment is fully under software control and can be changed “on-the-fly” during program execution.

## 11.4 Timer0 Interrupt

The TMR0 interrupt is generated when the TMR0 register overflows from FFh to 00h in 8-bit mode or from FFFFh to 0000h in 16-bit mode. This overflow sets the TMR0IF flag bit. The interrupt can be masked by clearing the TMR0IE bit (INTCON<5>). Before re-enabling the interrupt, the TMR0IF bit must be cleared in software by the Interrupt Service Routine.

Since Timer0 is shut down in Sleep mode, the TMR0 interrupt cannot awaken the processor from Sleep.

**TABLE 11-1: REGISTERS ASSOCIATED WITH TIMER0**

Name	Bit 7	Bit 6	Bit 5	Bit 4	Bit 3	Bit 2	Bit 1	Bit 0	Reset Values on page
TMR0L	Timer0 Register Low Byte								46
TMR0H	Timer0 Register High Byte								46
INTCON	GIE/GIEH	PEIE/GIEL	TMR0IE	INT0IE	RBIE	TMR0IF	INT0IF	RBIF	45
T0CON	TMR0ON	T08BIT	T0CS	T0SE	PSA	T0PS2	T0PS1	T0PS0	46
TRISA	TRISA7 <sup>(1)</sup>	TRISA6 <sup>(1)</sup>	TRISA5	TRISA4	TRISA3	TRISA2	TRISA1	TRISA0	48

Legend: — = unimplemented, read as ‘0’. Shaded cells are not used by Timer0.

**Note 1:** RA<7:6> and their associated latch and direction bits are configured as port pins only when the internal oscillator is selected as the default clock source (FOSC2 Configuration bit = 0); otherwise, they are disabled and these bits read as ‘0’.

## 12.0 TIMER1 MODULE

The Timer1 timer/counter module incorporates these features:

- Software selectable operation as a 16-bit timer or counter
- Readable and writable 8-bit registers (TMR1H and TMR1L)
- Selectable clock source (internal or external) with device clock or Timer1 oscillator internal options
- Interrupt-on-overflow
- Reset on CCP Special Event Trigger
- Device clock status flag (T1RUN)

A simplified block diagram of the Timer1 module is shown in [Figure 12-1](#). A block diagram of the module's operation in Read/Write mode is shown in [Figure 12-2](#).

The module incorporates its own low-power oscillator to provide an additional clocking option. The Timer1 oscillator can also be used as a low-power clock source for the microcontroller in power-managed operation.

Timer1 can also be used to provide Real-Time Clock (RTC) functionality to applications with only a minimal addition of external components and code overhead.

Timer1 is controlled through the T1CON Control register ([Register 12-1](#)). It also contains the Timer1 Oscillator Enable bit (T1OSCEN). Timer1 can be enabled or disabled by setting or clearing control bit, TMR1ON (T1CON<0>).

**REGISTER 12-1: T1CON: TIMER1 CONTROL REGISTER**

R/W-0	R-0	R/W-0	R/W-0	R/W-0	R/W-0	R/W-0	R/W-0
RD16	T1RUN	T1CKPS1	T1CKPS0	T1OSCEN	$\overline{T1SYNC}$	TMR1CS	TMR1ON
bit 7							bit 0

Legend:

R = Readable bit

W = Writable bit

U = Unimplemented bit, read as '0'

-n = Value at POR

'1' = Bit is set

'0' = Bit is cleared

x = Bit is unknown

- bit 7      **RD16:** 16-Bit Read/Write Mode Enable bit  
 1 = Enables register read/write of Timer1 in one 16-bit operation  
 0 = Enables register read/write of Timer1 in two 8-bit operations
- bit 6      **T1RUN:** Timer1 System Clock Status bit  
 1 = Device clock is derived from Timer1 oscillator  
 0 = Device clock is derived from another source
- bit 5-4    **T1CKPS<1:0>:** Timer1 Input Clock Prescale Select bits  
 11 = 1:8 Prescale value  
 10 = 1:4 Prescale value  
 01 = 1:2 Prescale value  
 00 = 1:1 Prescale value
- bit 3      **T1OSCEN:** Timer1 Oscillator Enable bit  
 1 = Timer1 oscillator is enabled  
 0 = Timer1 oscillator is shut off  
 The oscillator inverter and feedback resistor are turned off to eliminate power drain.
- bit 2       **$\overline{T1SYNC}$ :** Timer1 External Clock Input Synchronization Select bit  
 When TMR1CS = 1:  
 1 = Do not synchronize external clock input  
 0 = Synchronize external clock input  
 When TMR1CS = 0:  
 This bit is ignored. Timer1 uses the internal clock when TMR1CS = 0.
- bit 1      **TMR1CS:** Timer1 Clock Source Select bit  
 1 = External clock from pin, RC0/T1OSO/T13CKI (on the rising edge)  
 0 = Internal clock (FOSC/4)
- bit 0      **TMR1ON:** Timer1 On bit  
 1 = Enables Timer1  
 0 = Stops Timer1

# PIC18F87J72

## 12.1 Timer1 Operation

Timer1 can operate in one of these modes:

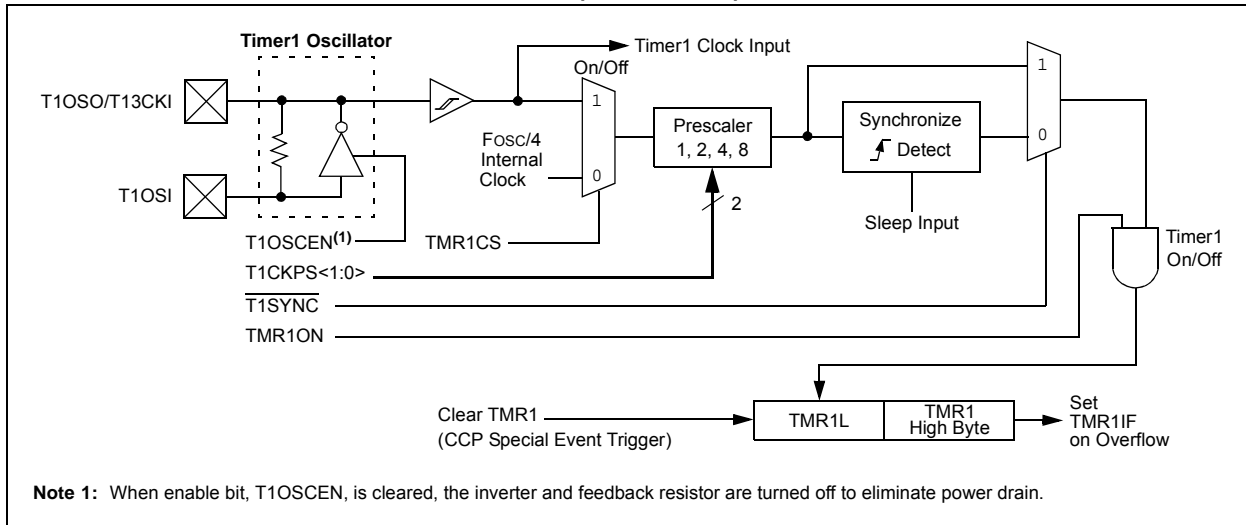
- Timer
- Synchronous Counter
- Asynchronous Counter

The operating mode is determined by the clock select bit, TMR1CS (T1CON<1>). When TMR1CS is cleared (= 0), Timer1 increments on every internal instruction cycle ( $F_{osc}/4$ ).

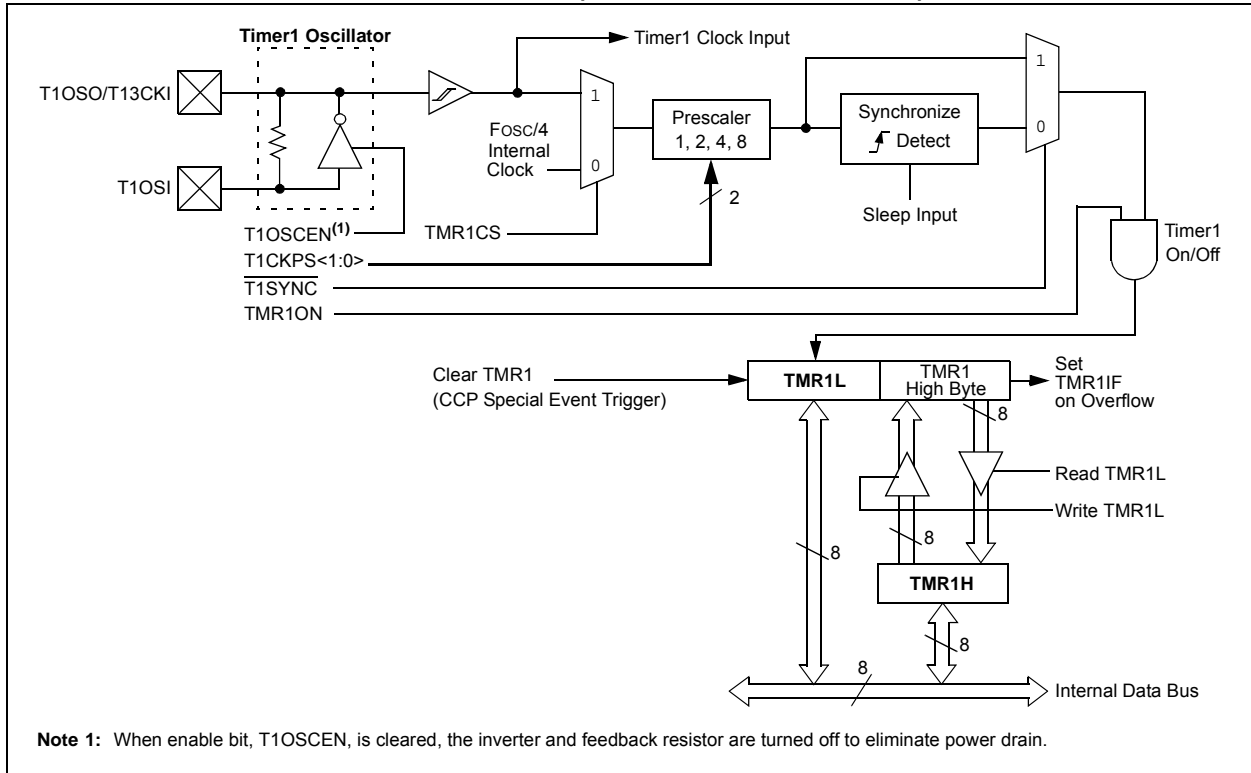
When the bit is set, Timer1 increments on every rising edge of the Timer1 external clock input or the Timer1 oscillator, if enabled.

When Timer1 is enabled, the RC1/T1OSI/SEG32 and RC0/T1OSO/T13CKI pins become inputs. This means the values of TRISC<1:0> are ignored and the pins are read as '0'.

**FIGURE 12-1: TIMER1 BLOCK DIAGRAM (8-BIT MODE)**



**FIGURE 12-2: TIMER1 BLOCK DIAGRAM (16-BIT READ/WRITE MODE)**



## 12.2 Timer1 16-Bit Read/Write Mode

Timer1 can be configured for 16-bit reads and writes (see Figure 12-2). When the RD16 control bit (T1CON<7>) is set, the address for TMR1H is mapped to a buffer register for the high byte of Timer1. A read from TMR1L will load the contents of the high byte of Timer1 into the Timer1 High Byte Buffer register. This provides the user with the ability to accurately read all 16 bits of Timer1 without having to determine whether a read of the high byte, followed by a read of the low byte, has become invalid due to a rollover between reads.

A write to the high byte of Timer1 must also take place through the TMR1H Buffer register. The Timer1 high byte is updated with the contents of TMR1H when a write occurs to TMR1L. This allows a user to write all 16 bits to both the high and low bytes of Timer1 at once.

The high byte of Timer1 is not directly readable or writable in this mode. All reads and writes must take place through the Timer1 High Byte Buffer register. Writes to TMR1H do not clear the Timer1 prescaler. The prescaler is only cleared on writes to TMR1L.

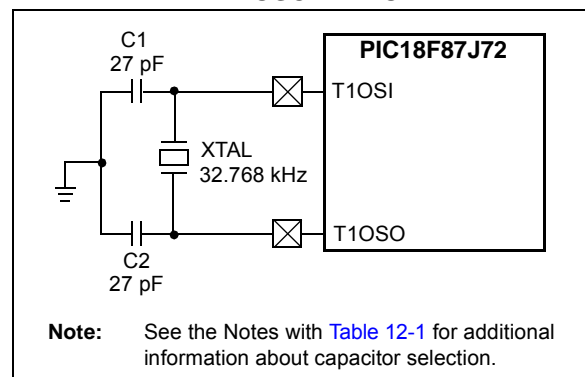
## 12.3 Timer1 Oscillator

An on-chip crystal oscillator circuit is incorporated between pins, T1OSI (input) and T1OSO (amplifier output). It is enabled by setting the Timer1 Oscillator Enable bit, T1OSCEN (T1CON<3>). The oscillator is a low-power circuit rated for 32 kHz crystals. It will

continue to run during all power-managed modes. The circuit for a typical LP oscillator is shown in Figure 12-3. Table 12-1 shows the capacitor selection for the Timer1 oscillator.

The user must provide a software time delay to ensure proper start-up of the Timer1 oscillator.

**FIGURE 12-3: EXTERNAL COMPONENTS FOR THE TIMER1 LP OSCILLATOR**



**TABLE 12-1: CAPACITOR SELECTION FOR THE TIMER1 OSCILLATOR<sup>(2,3,4)</sup>**

Oscillator Type	Freq.	C1	C2
LP	32.768 kHz	27 pF <sup>(1)</sup>	27 pF <sup>(1)</sup>

**Note 1:** Microchip suggests these values as a starting point in validating the oscillator circuit.

**2:** Higher capacitance increases the stability of the oscillator but also increases the start-up time.

**3:** Since each resonator/crystal has its own characteristics, the user should consult the resonator/crystal manufacturer for appropriate values of external components.

**4:** Capacitor values are for design guidance only.

### 12.3.1 USING TIMER1 AS A CLOCK SOURCE

The Timer1 oscillator is also available as a clock source in power-managed modes. By setting the System Clock Select bits, SCS<1:0> (OSCCON<1:0>), to '01', the device switches to SEC\_RUN mode. Both the CPU and peripherals are clocked from the Timer1 oscillator. If the IDLEN bit (OSCCON<7>) is cleared and a SLEEP instruction is executed, the device enters SEC\_IDLE mode. Additional details are available in [Section 4.0 "Power-Managed Modes"](#).

Whenever the Timer1 oscillator is providing the clock source, the Timer1 system clock status flag, T1RUN (T1CON<6>), is set. This can be used to determine the controller's current clocking mode. It can also indicate the clock source being currently used by the Fail-Safe Clock Monitor. If the Clock Monitor is enabled and the Timer1 oscillator fails while providing the clock, polling the T1RUN bit will indicate whether the clock is being provided by the Timer1 oscillator or another source.

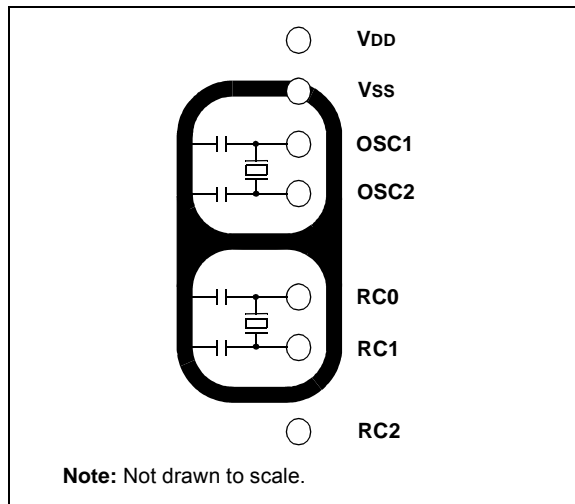
## 12.3.2 TIMER1 OSCILLATOR LAYOUT CONSIDERATIONS

The Timer1 oscillator circuit draws very little power during operation. Due to the low-power nature of the oscillator, it may also be sensitive to rapidly changing signals in close proximity.

The oscillator circuit, shown in [Figure 12-3](#), should be located as close as possible to the microcontroller. There should be no circuits passing within the oscillator circuit boundaries other than VSS or VDD.

If a high-speed circuit must be located near the oscillator (such as the CCP1 pin in Output Compare or PWM mode, or the primary oscillator using the OSC2 pin), a grounded guard ring around the oscillator circuit, as shown in [Figure 12-4](#), may be helpful when used on a single-sided PCB or in addition to a ground plane.

**FIGURE 12-4: OSCILLATOR CIRCUIT WITH GROUNDED GUARD RING**



## 12.4 Timer1 Interrupt

The TMR1 register pair (TMR1H:TMR1L) increments from 0000h to FFFFh and rolls over to 0000h. The Timer1 interrupt, if enabled, is generated on overflow which is latched in interrupt flag bit, TMR1IF (PIR1<0>). This interrupt can be enabled or disabled by setting or clearing the Timer1 Interrupt Enable bit, TMR1IE (PIE1<0>).

## 12.5 Resetting Timer1 Using the CCP Special Event Trigger

If CCP1 or CCP2 is configured to use Timer1 and to generate a Special Event Trigger in Compare mode (CCPxM<3:0> = 1011), this signal will reset Timer3. The trigger from CCP2 will also start an A/D conversion if the A/D module is enabled (see [Section 16.3.4 “Special Event Trigger”](#) for more information).

The module must be configured as either a timer or a synchronous counter to take advantage of this feature. When used this way, the CCPRxH:CCPRxL register pair effectively becomes a period register for Timer1.

If Timer1 is running in Asynchronous Counter mode, this Reset operation may not work.

In the event that a write to Timer1 coincides with a Special Event Trigger, the write operation will take precedence.

**Note:** The Special Event Triggers from the CCPx module will not set the TMR1IF interrupt flag bit (PIR1<0>).

## 12.6 Using Timer1 as a Real-Time Clock

Adding an external LP oscillator to Timer1 (such as the one described in [Section 12.3 “Timer1 Oscillator”](#) above) gives users the option to include RTC functionality to their applications. This is accomplished with an inexpensive watch crystal to provide an accurate time base and several lines of application code to calculate the time. When operating in Sleep mode and using a battery or supercapacitor as a power source, it can completely eliminate the need for a separate RTC device and battery backup.

The application code routine, *RTCisr*, shown in [Example 12-1](#), demonstrates a simple method to increment a counter at one-second intervals using an Interrupt Service Routine. Incrementing the TMR1 register pair to overflow triggers the interrupt and calls the routine which increments the seconds counter by one. Additional counters for minutes and hours are incremented as the previous counter overflows.

Since the register pair is 16 bits wide, counting up to overflow the register directly from a 32.768 kHz clock would take 2 seconds. To force the overflow at the required one-second intervals, it is necessary to preload it. The simplest method is to set the MSb of TMR1H with a *BSF* instruction. Note that the TMR1L register is never preloaded or altered; doing so may introduce cumulative error over many cycles.

For this method to be accurate, Timer1 must operate in Asynchronous mode and the Timer1 overflow interrupt must be enabled (PIE1<0> = 1) as shown in the routine, *RTCinit*. The Timer1 oscillator must also be enabled and running at all times.

# PIC18F87J72

## EXAMPLE 12-1: IMPLEMENTING A REAL-TIME CLOCK USING A TIMER1 INTERRUPT SERVICE

```

RTCinit
    MOVLW    80h           ; Preload TMR1 register pair
    MOVWF   TMR1H         ; for 1 second overflow
    CLRF    TMR1L
    MOVLW   b'00001111'   ; Configure for external clock,
    MOVWF   T1CON         ; Asynchronous operation, external oscillator
    CLRF    secs          ; Initialize timekeeping registers
    CLRF    mins          ;
    MOVLW   .12
    MOVWF   hours
    BSF     PIE1, TMR1IE  ; Enable Timer1 interrupt
    RETURN

RTCisr
    BSF     TMR1H, 7      ; Preload for 1 sec overflow
    BCF     PIR1, TMR1IF  ; Clear interrupt flag
    INCF    secs, F       ; Increment seconds
    MOVLW   .59           ; 60 seconds elapsed?
    CPFSGT  secs
    RETURN                ; No, done
    CLRF    secs          ; Clear seconds
    INCF    mins, F       ; Increment minutes
    MOVLW   .59           ; 60 minutes elapsed?
    CPFSGT  mins
    RETURN                ; No, done
    CLRF    mins          ; clear minutes
    INCF    hours, F      ; Increment hours
    MOVLW   .23           ; 24 hours elapsed?
    CPFSGT  hours
    RETURN                ; No, done
    CLRF    hours        ; Reset hours
    RETURN                ; Done
    
```

**TABLE 12-2: REGISTERS ASSOCIATED WITH TIMER1 AS A TIMER/COUNTER**

Name	Bit 7	Bit 6	Bit 5	Bit 4	Bit 3	Bit 2	Bit 1	Bit 0	Reset Values on page
INTCON	GIE/GIEH	PEIE/GIE L	TMR0IE	INT0IE	RBIE	TMR0IF	INT0IF	RBIF	45
PIR1	—	ADIF	RC1IF	TX1IF	SSPIF	—	TMR2IF	TMR1IF	48
PIE1	—	ADIE	RC1IE	TX1IE	SSPIE	—	TMR2IE	TMR1IE	48
IPR1	—	ADIP	RC1IP	TX1IP	SSPIP	—	TMR2IP	TMR1IP	48
TMR1L	Timer1 Register Low Byte								46
TMR1H	Timer1 Register High Byte								46
T1CON	RD16	T1RUN	T1CKPS1	T1CKPS0	T1OS-CEN	T1SYNC	TMR1CS	TMR1ON	46

Legend: Shaded cells are not used by the Timer1 module.



## 13.0 TIMER2 MODULE

The Timer2 module incorporates the following features:

- 8-bit Timer and Period registers (TMR2 and PR2, respectively)
- Readable and writable (both registers)
- Software programmable prescaler (1:1, 1:4 and 1:16)
- Software programmable postscaler (1:1 through 1:16)
- Interrupt on TMR2 to PR2 match
- Optional use as the shift clock for the MSSP module

The module is controlled through the T2CON register (Register 13-1), which enables or disables the timer and configures the prescaler and postscaler. Timer2 can be shut off by clearing control bit, TMR2ON (T2CON<2>), to minimize power consumption.

A simplified block diagram of the module is shown in Figure 13-1.

## 13.1 Timer2 Operation

In normal operation, TMR2 is incremented from 00h on each clock ( $F_{osc}/4$ ). A 4-bit counter/prescaler on the clock input gives direct input, divide-by-4 and divide-by-16 prescale options. These are selected by the prescaler control bits, T2CKPS<1:0> (T2CON<1:0>). The value of TMR2 is compared to that of the Period register, PR2, on each clock cycle. When the two values match, the comparator generates a match signal as the timer output. This signal also resets the value of TMR2 to 00h on the next cycle and drives the output counter/postscaler (see Section 13.2 “Timer2 Interrupt”).

The TMR2 and PR2 registers are both directly readable and writable. The TMR2 register is cleared on any device Reset, while the PR2 register initializes at FFh. Both the prescaler and postscaler counters are cleared on the following events:

- a write to the TMR2 register
- a write to the T2CON register
- any device Reset (Power-on Reset,  $\overline{MCLR}$  Reset, Watchdog Timer Reset or Brown-out Reset)

TMR2 is not cleared when T2CON is written.

**REGISTER 13-1: T2CON: TIMER2 CONTROL REGISTER**

U-0	R/W-0	R/W-0	R/W-0	R/W-0	R/W-0	R/W-0	R/W-0
—	T2OUTPS3	T2OUTPS2	T2OUTPS1	T2OUTPS0	TMR2ON	T2CKPS1	T2CKPS0
bit 7							bit 0

Legend:

R = Readable bit  
-n = Value at POR

W = Writable bit  
'1' = Bit is set

U = Unimplemented bit, read as '0'  
'0' = Bit is cleared  
x = Bit is unknown

- bit 7      **Unimplemented:** Read as '0'
- bit 6-3    **T2OUTPS<3:0>:** Timer2 Output Postscale Select bits  
           0000 = 1:1 Postscale  
           0001 = 1:2 Postscale  
           •  
           •  
           •  
           1111 = 1:16 Postscale
- bit 2      **TMR2ON:** Timer2 On bit  
           1 = Timer2 is on  
           0 = Timer2 is off
- bit 1-0    **T2CKPS<1:0>:** Timer2 Clock Prescale Select bits  
           00 = Prescaler is 1  
           01 = Prescaler is 4  
           1x = Prescaler is 16

# PIC18F87J72

## 13.2 Timer2 Interrupt

Timer2 can also generate an optional device interrupt. The Timer2 output signal (TMR2 to PR2 match) provides the input for the 4-bit output counter/postscaler. This counter generates the TMR2 match interrupt flag which is latched in TMR2IF (PIR1<1>). The interrupt is enabled by setting the TMR2 Match Interrupt Enable bit, TMR2IE (PIE1<1>).

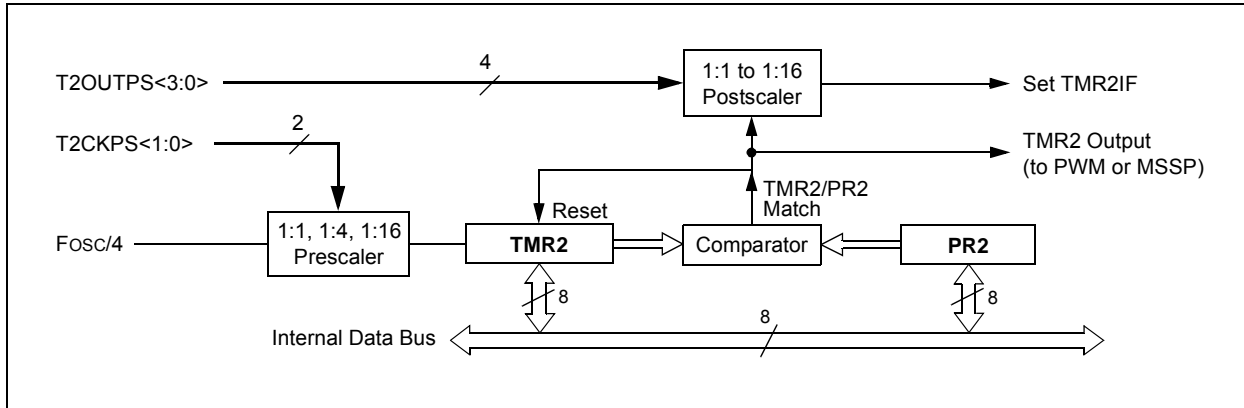
A range of 16 postscale options (from 1:1 through 1:16 inclusive) can be selected with the postscaler control bits, T2OUTPS<3:0> (T2CON<6:3>).

## 13.3 Timer2 Output

The unscaled output of TMR2 is available primarily to the CCP modules, where it is used as a time base for operations in PWM mode.

Timer2 can be optionally used as the shift clock source for the MSSP module operating in SPI mode. Additional information is provided in [Section 18.0 “Master Synchronous Serial Port \(MSSP\) Module”](#).

**FIGURE 13-1: TIMER2 BLOCK DIAGRAM**



**TABLE 13-1: REGISTERS ASSOCIATED WITH TIMER2 AS A TIMER/COUNTER**

Name	Bit 7	Bit 6	Bit 5	Bit 4	Bit 3	Bit 2	Bit 1	Bit 0	Reset Values on page
INT-CON	GIE/GIEH	PEIE/GIEL	TMR0IE	INT0IE	RBIE	TMR0IF	INT0IF	RBIF	45
PIR1	—	ADIF	RC1IF	TX1IF	SSPIF	—	TMR2IF	TMR1IF	48
PIE1	—	ADIE	RC1IE	TX1IE	SSPIE	—	TMR2IE	TMR1IE	48
IPR1	—	ADIP	RC1IP	TX1IP	SSPIP	—	TMR2IP	TMR1IP	48
TMR2	Timer2 Register								46
T2CON	—	T2OUTPS3	T2OUTPS2	T2OUTPS1	T2OUTPS0	TMR2ON	T2CKPS1	T2CKPS0	46
PR2	Timer2 Period Register								46

Legend: — = unimplemented, read as '0'. Shaded cells are not used by the Timer2 module.

## 14.0 TIMER3 MODULE

The Timer3 timer/counter module incorporates these features:

- Software selectable operation as a 16-bit timer or counter
- Readable and writable 8-bit registers (TMR3H and TMR3L)
- Selectable clock source (internal or external) with device clock or Timer1 oscillator internal options
- Interrupt-on-overflow
- Module Reset on CCP Special Event Trigger

A simplified block diagram of the Timer3 module is shown in [Figure 14-1](#). A block diagram of the module's operation in Read/Write mode is shown in [Figure 14-2](#).

The Timer3 module is controlled through the T3CON register ([Register 14-1](#)). It also selects the clock source options for the CCP modules. See [Section 16.2.2 "Timer1/Timer3 Mode Selection"](#) for more information.

**REGISTER 14-1: T3CON: TIMER3 CONTROL REGISTER**

R/W-0	R/W-0	R/W-0	R/W-0	R/W-0	R/W-0	R/W-0	R/W-0
RD16	T3CCP2	T3CKPS1	T3CKPS0	T3CCP1	$\overline{T3SYNC}$	TMR3CS	TMR3ON
bit 7							bit 0

Legend:

R = Readable bit

W = Writable bit

U = Unimplemented bit, read as '0'

-n = Value at POR

'1' = Bit is set

'0' = Bit is cleared

x = Bit is unknown

- bit 7      **RD16:** 16-Bit Read/Write Mode Enable bit  
 1 = Enables register read/write of Timer3 in one 16-bit operation  
 0 = Enables register read/write of Timer3 in two 8-bit operations
- bit 6,3    **T3CCP<2:1>:** Timer3 and Timer1 to CCPx Enable bits  
 1x = Timer3 is the capture/compare clock source for the CCP modules  
 01 = Timer3 is the capture/compare clock source for CCP2;  
       Timer1 is the capture/compare clock source for CCP1  
 00 = Timer1 is the capture/compare clock source for the CCP modules
- bit 5-4    **T3CKPS<1:0>:** Timer3 Input Clock Prescale Select bits  
 11 = 1:8 Prescale value  
 10 = 1:4 Prescale value  
 01 = 1:2 Prescale value  
 00 = 1:1 Prescale value
- bit 2       **$\overline{T3SYNC}$ :** Timer3 External Clock Input Synchronization Control bit  
 (Not usable if the device clock comes from Timer1/Timer3.)  
 When TMR3CS = 1:  
 1 = Do not synchronize external clock input  
 0 = Synchronize external clock input  
 When TMR3CS = 0:  
 This bit is ignored. Timer3 uses the internal clock when TMR3CS = 0.
- bit 1      **TMR3CS:** Timer3 Clock Source Select bit  
 1 = External clock input from Timer1 oscillator or T13CKI (on the rising edge after the first falling edge)  
 0 = Internal clock (FOSC/4)
- bit 0      **TMR3ON:** Timer3 On bit  
 1 = Enables Timer3  
 0 = Stops Timer3

# PIC18F87J72

## 14.1 Timer3 Operation

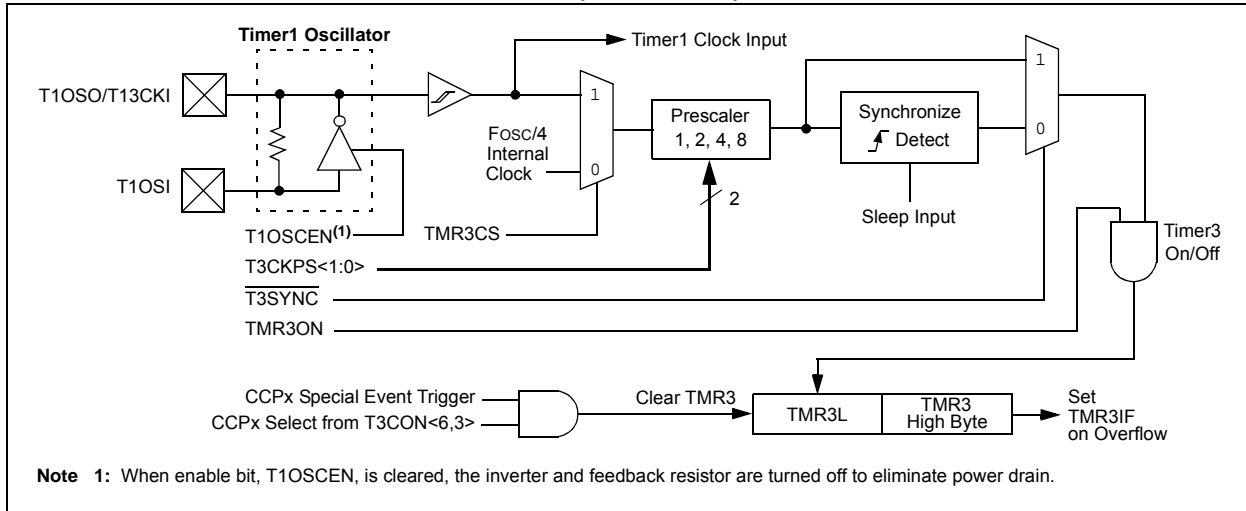
Timer3 can operate in one of three modes:

- Timer
- Synchronous Counter
- Asynchronous Counter

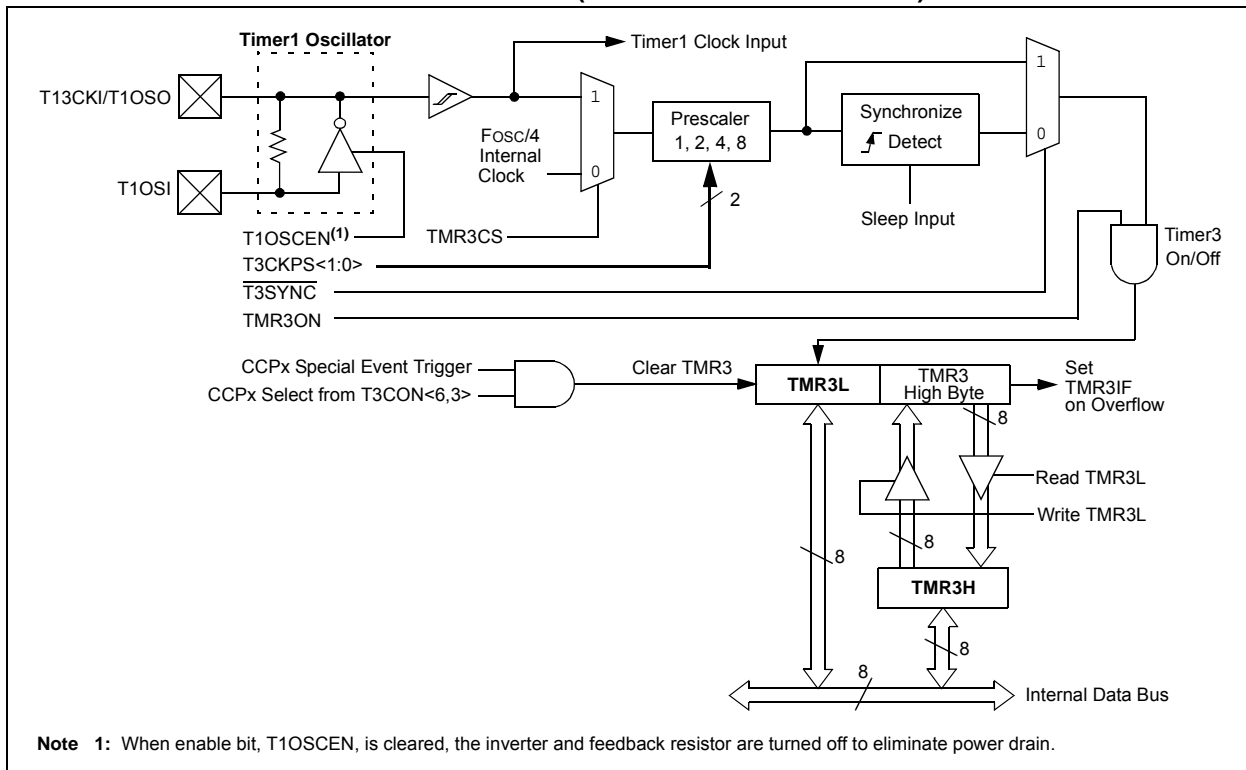
The operating mode is determined by the clock select bit, TMR3CS (T3CON<1>). When TMR3CS is cleared (= 0), Timer3 increments on every internal instruction cycle ( $F_{osc}/4$ ). When the bit is set, Timer3 increments on every rising edge of the Timer1 external clock input or the Timer1 oscillator, if enabled.

As with Timer1, the RC1/T1OSI/SEG32 and RC0/T1OSO/T13CKI pins become inputs when the Timer1 oscillator is enabled. This means the values of TRISC<1:0> are ignored and the pins are read as '0'.

**FIGURE 14-1: TIMER3 BLOCK DIAGRAM (8-BIT MODE)**



**FIGURE 14-2: TIMER3 BLOCK DIAGRAM (16-BIT READ/WRITE MODE)**



## 14.2 Timer3 16-Bit Read/Write Mode

Timer3 can be configured for 16-bit reads and writes (see [Figure 14-2](#)). When the RD16 control bit (T3CON<7>) is set, the address for TMR3H is mapped to a buffer register for the high byte of Timer3. A read from TMR3L will load the contents of the high byte of Timer3 into the Timer3 High Byte Buffer register. This provides the user with the ability to accurately read all 16 bits of Timer1 without having to determine whether a read of the high byte, followed by a read of the low byte, has become invalid due to a rollover between reads.

A write to the high byte of Timer3 must also take place through the TMR3H Buffer register. The Timer3 high byte is updated with the contents of TMR3H when a write occurs to TMR3L. This allows a user to write all 16 bits to both the high and low bytes of Timer3 at once.

The high byte of Timer3 is not directly readable or writable in this mode. All reads and writes must take place through the Timer3 High Byte Buffer register.

Writes to TMR3H do not clear the Timer3 prescaler. The prescaler is only cleared on writes to TMR3L.

## 14.3 Using the Timer1 Oscillator as the Timer3 Clock Source

The Timer1 internal oscillator may be used as the clock source for Timer3. The Timer1 oscillator is enabled by setting the T1OSCEN (T1CON<3>) bit. To use it as the Timer3 clock source, the TMR3CS bit must also be set. As previously noted, this also configures Timer3 to increment on every rising edge of the oscillator source.

The Timer1 oscillator is described in [Section 12.0 “Timer1 Module”](#).

## 14.4 Timer3 Interrupt

The TMR3 register pair (TMR3H:TMR3L) increments from 0000h to FFFFh and overflows to 0000h. The Timer3 interrupt, if enabled, is generated on overflow and is latched in interrupt flag bit, TMR3IF (PIR2<1>). This interrupt can be enabled or disabled by setting or clearing the Timer3 Interrupt Enable bit, TMR3IE (PIE2<1>).

## 14.5 Resetting Timer3 Using the CCP Special Event Trigger

If CCP1 or CCP2 is configured to use Timer3 and to generate a Special Event Trigger in Compare mode (CCPxM<3:0> = 1011), this signal will reset Timer3. The trigger from CCP2 will also start an A/D conversion if the A/D module is enabled (see [Section 16.3.4 “Special Event Trigger”](#) for more information).

The module must be configured as either a timer or synchronous counter to take advantage of this feature. When used this way, the CCPxH:CCPxL register pair effectively becomes a period register for Timer3.

If Timer3 is running in Asynchronous Counter mode, the Reset operation may not work.

In the event that a write to Timer3 coincides with a Special Event Trigger from a CCP module, the write will take precedence.

**Note:** The Special Event Triggers from the CCPx module will not set the TMR3IF interrupt flag bit (PIR2<1>).

**TABLE 14-1: REGISTERS ASSOCIATED WITH TIMER3 AS A TIMER/COUNTER**

Name	Bit 7	Bit 6	Bit 5	Bit 4	Bit 3	Bit 2	Bit 1	Bit 0	Reset Values on page
INTCON	GIE/GIEH	PEIE/GIEL	TMR0IE	INT0IE	RBIE	TMR0IF	INT0IF	RBIF	45
PIR2	OSCFIF	CMIF	—	—	BCLIF	LVDIF	TMR3IF	—	48
PIE2	OSCFIE	CMIE	—	—	BCLIE	LVDIE	TMR3IE	—	48
IPR2	OSCFIP	CMIP	—	—	BCLIP	LVDIP	TMR3IP	—	48
TMR3L	Timer3 Register Low Byte								47
TMR3H	Timer3 Register High Byte								47
T1CON	RD16	T1RUN	T1CKPS1	T1CKPS0	T1OSCEN	T1SYN $\bar{C}$	TMR1CS	TMR1ON	46
T3CON	RD16	T3CCP2	T3CKPS1	T3CKPS0	T3CCP1	T3SYN $\bar{C}$	TMR3CS	TMR3ON	47

Legend: — = unimplemented, read as '0'. Shaded cells are not used by the Timer3 module.

# PIC18F87J72

## 15.0 REAL-TIME CLOCK AND CALENDAR (RTCC)

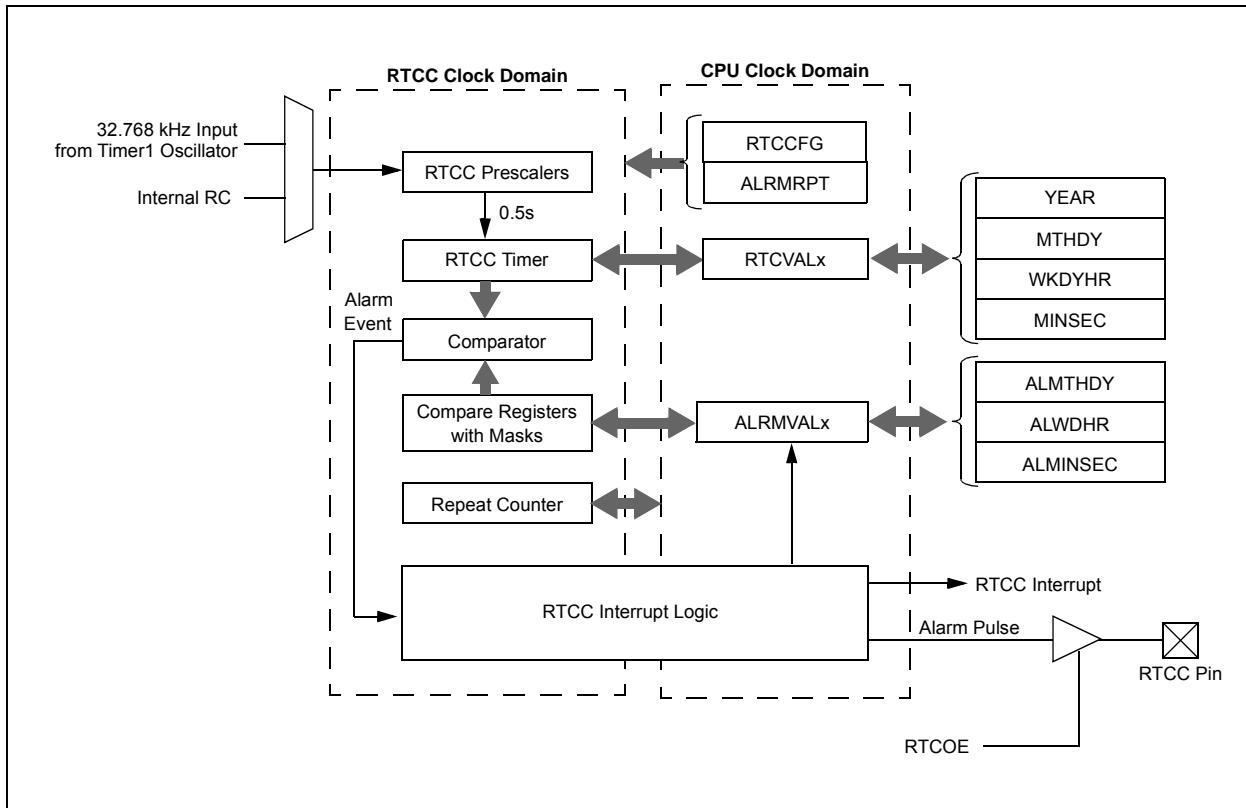
The key features of the Real-Time Clock and Calendar (RTCC) module are:

- Time: hours, minutes and seconds
- 24-hour format (military time)
- Calendar: weekday, date, month and year
- Alarm configurable
- Year range: 2000 to 2099
- Leap year correction
- BCD format for compact firmware
- Optimized for low-power operation
- User calibration with auto-adjust
- Calibration range:  $\pm 2.64$  seconds error per month
- Requirements: external 32.768 kHz clock crystal
- Alarm pulse or seconds clock output on RTCC pin

The RTCC module is intended for applications, where accurate time must be maintained for an extended period with minimum to no intervention from the CPU. The module is optimized for low-power usage in order to provide extended battery life while keeping track of time.

The module is a 100-year clock and calendar with automatic leap year detection. The range of the clock is from 00:00:00 (midnight) on January 1, 2000 to 23:59:59 on December 31, 2099. Hours are measured in 24-hour (military time) format. The clock provides a granularity of one second with half-second visibility to the user.

**FIGURE 15-1: RTCC BLOCK DIAGRAM**



## 15.1 RTCC MODULE REGISTERS

The RTCC module registers are divided into following categories:

### RTCC Control Registers

- RTCCFG
- RTCCAL
- PADCFG1
- ALRMCFG
- ALMRPT

### RTCC Value Registers

- RTCVALH and RTCVALL – Can access the following registers
  - YEAR
  - MONTH
  - DAY
  - WEEKDAY
  - HOUR
  - MINUTE
  - SECOND

### Alarm Value Registers

- ALRMVALH and ALRMVALL – Can access the following registers:
  - ALRMMNTH
  - ALRMDAY
  - ALRMWD
  - ALRMHR
  - ALRMMIN
  - ALRMSEC

**Note:** The RTCVALH and RTCVALL registers can be accessed through RTCRPT<1:0>. ALRMVALH and ALRMVALL can be accessed through ALRMPTR<1:0>.

# PIC18F87J72

## 15.1.1 RTCC CONTROL REGISTERS

### REGISTER 15-1: RTCCFG: RTCC CONFIGURATION REGISTER<sup>(1)</sup>

R/W-0	U-0	R/W-0	R-0	R-0	R/W-0	R/W-0	R/W-0
RTCEN <sup>(2)</sup>	—	RTCWREN	RTCSYNC	HALFSEC <sup>(3)</sup>	RTCOE	RTCPTR1	RTCPTR0
bit 7							bit 0

#### Legend:

R = Readable bit                      W = Writable bit                      U = Unimplemented bit, read as '0'  
 -n = Value at POR                      '1' = Bit is set                      '0' = Bit is cleared                      x = Bit is unknown

- bit 7            **RTCEN:** RTCC Enable bit<sup>(2)</sup>  
                   1 = RTCC module is enabled  
                   0 = RTCC module is disabled
- bit 6            **Unimplemented:** Read as '0'
- bit 5            **RTCWREN:** RTCC Value Registers Write Enable bit  
                   1 = RTCVALH and RTCVALL registers can be written to by the user  
                   0 = RTCVALH and RTCVALL registers are locked out from being written to by the user
- bit 4            **RTCSYNC:** RTCC Value Registers Read Synchronization bit  
                   1 = RTCVALH, RTCVALL and ALMRPT registers can change while reading due to a rollover ripple resulting in an invalid data read. If the register is read twice and results in the same data, the data can be assumed to be valid.  
                   0 = RTCVALH, RTCVALL and ALCFGRPT registers can be read without concern over a rollover ripple
- bit 3            **HALFSEC:** Half-Second Status bit<sup>(3)</sup>  
                   1 = Second half period of a second  
                   0 = First half period of a second
- bit 2            **RTCOE:** RTCC Output Enable bit  
                   1 = RTCC clock output is enabled  
                   0 = RTCC clock output is disabled
- bit 1-0        **RTCPTR<1:0>:** RTCC Value Register Window Pointer bits  
                   Points to the corresponding RTCC Value registers when reading RTCVALH and RTCVALL registers. The RTCPTR<1:0> value decrements on every read or write of RTCVALH<7:0> until it reaches '00'.  
                   RTCVALH:  
                   00 = Minutes  
                   01 = Weekday  
                   10 = Month  
                   11 = Reserved  
                   RTCVALL:  
                   00 = Seconds  
                   01 = Hours  
                   10 = Day  
                   11 = Year

- Note 1:** The RTCCFG register is only affected by a POR. For Resets other than POR, RTCC will continue to run even if the device is in Reset.
- 2:** A write to the RTCEN bit is only allowed when RTCWREN = 1.
- 3:** This bit is read-only; it is cleared to '0' on a write to the lower half of the MINSEC register.



## REGISTER 15-2: RTCCAL: RTCC CALIBRATION REGISTER

R/W-0	R/W-0	R/W-0	R/W-0	R/W-0	R/W-0	R/W-0	R/W-0
CAL7	CAL6	CAL5	CAL4	CAL3	CAL2	CAL1	CAL0
bit 7							bit 0

### Legend:

R = Readable bit                      W = Writable bit                      U = Unimplemented bit, read as '0'  
-n = Value at POR                      '1' = Bit is set                      '0' = Bit is cleared                      x = Bit is unknown

bit 7-0                      **CAL<7:0>**: RTC Drift Calibration bits  
01111111 = Maximum positive adjustment; adds 508 RTC clock pulses every minute  
.  
.  
.  
00000001 = Minimum positive adjustment; adds four RTC clock pulses every minute  
00000000 = No adjustment  
11111111 = Minimum negative adjustment; subtracts four RTC clock pulses every minute  
.  
.  
.  
10000000 = Maximum negative adjustment; subtracts 512 RTC clock pulses every minute

## REGISTER 15-3: PADCFG1: PAD CONFIGURATION REGISTER

U-0	U-0	U-0	U-0	U-0	R/W-0	R/W-0	U-0
—	—	—	—	—	RTSEC-SEL1 <sup>(1)</sup>	RTSEC-SEL0 <sup>(1)</sup>	—
bit 7							bit 0

### Legend:

R = Readable bit                      W = Writable bit                      U = Unimplemented bit, read as '0'  
-n = Value at POR                      '1' = Bit is set                      '0' = Bit is cleared                      x = Bit is unknown

bit 7-3                      **Unimplemented:** Read as '0'  
bit 2-1                      **RTSECSEL<1:0>**: RTCC Seconds Clock Output Select bits<sup>(1)</sup>  
11 = Reserved; do not use  
10 = RTCC source clock is selected for the RTCC pin (pin can be INTOSC or Timer1 oscillator, depending on the RTCOSC (CONFIG3L<1>) bit setting)<sup>(2)</sup>  
01 = RTCC seconds clock is selected for the RTCC pin  
00 = RTCC alarm pulse is selected for the RTCC pin  
bit 0                      **Unimplemented:** Read as '0'

- Note 1:** To enable the actual RTCC output, the RTCOE (RTCCFG<2>) bit must be set.  
**2:** If the Timer1 oscillator is the clock source for RTCC, T1OSCEN bit should be set (T1CON<3> = 1).

# PIC18F87J72

## REGISTER 15-4: ALRMCFG: ALARM CONFIGURATION REGISTER

R/W-0	R/W-0	R/W-0	R/W-0	R/W-0	R/W-0	R/W-0	R/W-0
ALRMEN	CHIME	AMASK3	AMASK2	AMASK1	AMASK0	ALRMPTR1	ALRMPTR0
bit 7							bit 0

### Legend:

R = Readable bit                      W = Writable bit                      U = Unimplemented bit, read as '0'  
 -n = Value at POR                      '1' = Bit is set                      '0' = Bit is cleared                      x = Bit is unknown

- bit 7            **ALRMEN:** Alarm Enable bit  
 1 = Alarm is enabled (cleared automatically after an alarm event whenever ARPT<7:0> = 00 and CHIME = 0)  
 0 = Alarm is disabled
- bit 6            **CHIME:** Chime Enable bit  
 1 = Chime is enabled; ALRMPTR<1:0> bits are allowed to roll over from 00h to FFh  
 0 = Chime is disabled; ALRMPTR<1:0> bits stop once they reach 00h
- bit 5-2        **AMASK<3:0>:** Alarm Mask Configuration bits  
 0000 = Every half second  
 0001 = Every second  
 0010 = Every 10 seconds  
 0011 = Every minute  
 0100 = Every 10 minutes  
 0101 = Every hour  
 0110 = Once a day  
 0111 = Once a week  
 1000 = Once a month  
 1001 = Once a year (except when configured for February 29<sup>th</sup>, once every four years)  
 101x = Reserved – do not use  
 11xx = Reserved – do not use
- bit 1-0        **ALRMPTR<1:0>:** Alarm Value Register Window Pointer bits  
 Points to the corresponding Alarm Value registers when reading the ALRMVALH and ALRMVALL registers. The ALRMPTR<1:0> value decrements on every read or write of ALRMVALH until it reaches '00'.  
ALRMVALH:  
 00 = ALRMMIN  
 01 = ALRMWD  
 10 = ALRMMNTH  
 11 = Unimplemented  
ALRMVALL:  
 00 = ALRMSEC  
 01 = ALRMHR  
 10 = ALRMDAY  
 11 = Unimplemented

## REGISTER 15-5: ALMRPT: ALARM CALIBRATION REGISTER

R/W-0	R/W-0	R/W-0	R/W-0	R/W-0	R/W-0	R/W-0	R/W-0
ARPT7	ARPT6	ARPT5	ARPT4	ARPT3	ARPT2	ARPT1	ARPT0
bit 7							bit 0

**Legend:**

R = Readable bit                      W = Writable bit                      U = Unimplemented bit, read as '0'  
 -n = Value at POR                      '1' = Bit is set                      '0' = Bit is cleared                      x = Bit is unknown

bit 7-0                      **ARPT<7:0>**: Alarm Repeat Counter Value bits  
 11111111 = Alarm will repeat 255 more times  
 .  
 .  
 .  
 00000000 = Alarm will not repeat  
 The counter decrements on any alarm event. The counter is prevented from rolling over from 00h to FFh unless CHIME = 1.

### 15.1.2 RTCVALH AND RTCVALL REGISTER MAPPINGS

## REGISTER 15-6: RESERVED REGISTER

U-0	U-0	U-0	U-0	U-0	U-0	U-0	U-0
—	—	—	—	—	—	—	—
bit 7							bit 0

**Legend:**

R = Readable bit                      W = Writable bit                      U = Unimplemented bit, read as '0'  
 -n = Value at POR                      '1' = Bit is set                      '0' = Bit is cleared                      x = Bit is unknown

bit 7-0                      **Unimplemented:** Read as '0'

## REGISTER 15-7: YEAR: YEAR VALUE REGISTER<sup>(1)</sup>

R/W-x	R/W-x	R/W-x	R/W-x	R/W-x	R/W-x	R/W-x	R/W-x
YRTEN3	YRTEN2	YRTEN1	YRTEN0	YRONE3	YRONE2	YRONE1	YRONE0
bit 7							bit 0

**Legend:**

R = Readable bit                      W = Writable bit                      U = Unimplemented bit, read as '0'  
 -n = Value at POR                      '1' = Bit is set                      '0' = Bit is cleared                      x = Bit is unknown

bit 7-4                      **YRTEN<3:0>**: Binary Coded Decimal Value of Year's Tens Digit bits  
 Contains a value from 0 to 9.

bit 3-0                      **YRONE<3:0>**: Binary Coded Decimal Value of Year's Ones Digit bits  
 Contains a value from 0 to 9.

**Note 1:** A write to the YEAR register is only allowed when RTCWREN = 1.

# PIC18F87J72

## REGISTER 15-8: MONTH: MONTH VALUE REGISTER<sup>(1)</sup>

U-0	U-0	U-0	R/W-x	R/W-x	R/W-x	R/W-x	R/W-x	
—	—	—	MHTTEN0	MTHONE3	MTHONE2	MTHONE1	MTHONE0	
bit 7								bit 0

### Legend:

R = Readable bit                      W = Writable bit                      U = Unimplemented bit, read as '0'  
 -n = Value at POR                      '1' = Bit is set                      '0' = Bit is cleared                      x = Bit is unknown

- bit 7-5            **Unimplemented:** Read as '0'
- bit 4            **MHTTEN0:** Binary Coded Decimal Value of Month's Tens Digit bits  
Contains a value of 0 or 1.
- bit 3-0           **MTHONE<3:0>:** Binary Coded Decimal Value of Month's Ones Digit bits  
Contains a value from 0 to 9.

**Note 1:** A write to this register is only allowed when RTCWREN = 1.

## REGISTER 15-9: DAY: DAY VALUE REGISTER<sup>(1)</sup>

U-0	U-0	R/W-x	R/W-x	R/W-x	R/W-x	R/W-x	R/W-x
—	—	DAYTEN1	DAYTEN0	DAYONE3	DAYONE2	DAYONE1	DAYONE0
bit 7						bit 0	

### Legend:

R = Readable bit                      W = Writable bit                      U = Unimplemented bit, read as '0'  
 -n = Value at POR                      '1' = Bit is set                      '0' = Bit is cleared                      x = Bit is unknown

- bit 7-6            **Unimplemented:** Read as '0'
- bit 5-4            **DAYTEN<1:0>:** Binary Coded Decimal value of Day's Tens Digit bits  
Contains a value from 0 to 3.
- bit 3-0            **DAYONE<3:0>:** Binary Coded Decimal Value of Day's Ones Digit bits  
Contains a value from 0 to 9.

**Note 1:** A write to this register is only allowed when RTCWREN = 1.

## REGISTER 15-10: WEEKDAY: WEEKDAY VALUE REGISTER<sup>(1)</sup>

U-0	U-0	U-0	U-0	U-0	R/W-x	R/W-x	R/W-x
—	—	—	—	—	WDAY2	WDAY1	WDAY0
bit 7					bit 0		

### Legend:

R = Readable bit                      W = Writable bit                      U = Unimplemented bit, read as '0'  
 -n = Value at POR                      '1' = Bit is set                      '0' = Bit is cleared                      x = Bit is unknown

- bit 7-3            **Unimplemented:** Read as '0'
- bit 2-0            **WDAY<2:0>:** Binary Coded Decimal Value of Weekday Digit bits  
Contains a value from 0 to 6.

**Note 1:** A write to this register is only allowed when RTCWREN = 1.

## REGISTER 15-11: HOUR: HOUR VALUE REGISTER<sup>(1)</sup>

U-0	U-0	R/W-x	R/W-x	R/W-x	R/W-x	R/W-x	R/W-x	
—	—	HRTEN1	HRTEN0	HRONE3	HRONE2	HRONE1	HRONE0	
bit 7								bit 0

Legend:

R = Readable bit                      W = Writable bit                      U = Unimplemented bit, read as '0'  
 -n = Value at POR                      '1' = Bit is set                      '0' = Bit is cleared                      x = Bit is unknown

- bit 7-6            **Unimplemented:** Read as '0'
- bit 5-4            **HRTEN<1:0>:** Binary Coded Decimal Value of Hour's Tens Digit bits  
Contains a value from 0 to 2.
- bit 3-0            **HRONE<3:0>:** Binary Coded Decimal Value of Hour's Ones Digit bits  
Contains a value from 0 to 9.

**Note 1:** A write to this register is only allowed when RTCWREN = 1.

## REGISTER 15-12: MINUTE: MINUTE VALUE REGISTER

U-0	R/W-x	R/W-x	R/W-x	R/W-x	R/W-x	R/W-x	R/W-x	
—	MINTEN2	MINTEN1	MINTEN0	MINONE3	MINONE2	MINONE1	MINONE0	
bit 7								bit 0

Legend:

R = Readable bit                      W = Writable bit                      U = Unimplemented bit, read as '0'  
 -n = Value at POR                      '1' = Bit is set                      '0' = Bit is cleared                      x = Bit is unknown

- bit 7            **Unimplemented:** Read as '0'
- bit 6-4            **MINTEN<2:0>:** Binary Coded Decimal Value of Minute's Tens Digit bits  
Contains a value from 0 to 5.
- bit 3-0            **MINONE<3:0>:** Binary Coded Decimal Value of Minute's Ones Digit bits  
Contains a value from 0 to 9.

## REGISTER 15-13: SECOND: SECOND VALUE REGISTER

U-0	R/W-x	R/W-x	R/W-x	R/W-x	R/W-x	R/W-x	R/W-x	
—	SECTEN2	SECTEN1	SECTEN0	SECONE3	SECONE2	SECONE1	SECONE0	
bit 7								bit 0

Legend:

R = Readable bit                      W = Writable bit                      U = Unimplemented bit, read as '0'  
 -n = Value at POR                      '1' = Bit is set                      '0' = Bit is cleared                      x = Bit is unknown

- bit 7            **Unimplemented:** Read as '0'
- bit 6-4            **SECTEN<2:0>:** Binary Coded Decimal Value of Second's Tens Digit bits  
Contains a value from 0 to 5.
- bit 3-0            **SECONE<3:0>:** Binary Coded Decimal Value of Second's Ones Digit bits  
Contains a value from 0 to 9.

# PIC18F87J72

## 15.1.3 ALRMVALH AND ALRMVALL REGISTER MAPPINGS

### REGISTER 15-14: ALRMMNTH: ALARM MONTH VALUE REGISTER<sup>(1)</sup>

U-0	U-0	U-0	R/W-x	R/W-x	R/W-x	R/W-x	R/W-x
—	—	—	MTHTEN0	MTHONE3	MTHONE2	MTHONE1	MTHONE0
bit 7							bit 0

Legend:

R = Readable bit                      W = Writable bit                      U = Unimplemented bit, read as '0'  
 -n = Value at POR                      '1' = Bit is set                      '0' = Bit is cleared                      x = Bit is unknown

bit 7-5                      **Unimplemented:** Read as '0'

bit 4                      **MTHTEN0:** Binary Coded Decimal Value of Month's Tens Digit bits  
 Contains a value of 0 or 1.

bit 3-0                      **MTHONE<3:0>:** Binary Coded Decimal Value of Month's Ones Digit bits  
 Contains a value from 0 to 9.

**Note 1:** A write to this register is only allowed when RTCWREN = 1.

### REGISTER 15-15: ALRMDAY: ALARM DAY VALUE REGISTER<sup>(1)</sup>

U-0	U-0	R/W-x	R/W-x	R/W-x	R/W-x	R/W-x	R/W-x
—	—	DAYTEN1	DAYTEN0	DAYONE3	DAYONE2	DAYONE1	DAYONE0
bit 7							bit 0

Legend:

R = Readable bit                      W = Writable bit                      U = Unimplemented bit, read as '0'  
 -n = Value at POR                      '1' = Bit is set                      '0' = Bit is cleared                      x = Bit is unknown

bit 7-6                      **Unimplemented:** Read as '0'

bit 5-4                      **DAYTEN<1:0>:** Binary Coded Decimal Value of Day's Tens Digit bits  
 Contains a value from 0 to 3.

bit 3-0                      **DAYONE<3:0>:** Binary Coded Decimal Value of Day's Ones Digit bits  
 Contains a value from 0 to 9.

**Note 1:** A write to this register is only allowed when RTCWREN = 1.

### REGISTER 15-16: ALRMWD: ALARM WEEKDAY VALUE REGISTER<sup>(1)</sup>

U-0	U-0	U-0	U-0	U-0	R/W-x	R/W-x	R/W-x
—	—	—	—	—	WDAY2	WDAY1	WDAY0
bit 7							bit 0

Legend:

R = Readable bit                      W = Writable bit                      U = Unimplemented bit, read as '0'  
 -n = Value at POR                      '1' = Bit is set                      '0' = Bit is cleared                      x = Bit is unknown

bit 7-3                      **Unimplemented:** Read as '0'

bit 2-0                      **WDAY<2:0>:** Binary Coded Decimal Value of Weekday Digit bits  
 Contains a value from 0 to 6.

**Note 1:** A write to this register is only allowed when RTCWREN = 1.

## REGISTER 15-17: ALRMHR: ALARM HOURS VALUE REGISTER<sup>(1)</sup>

U-0	U-0	R/W-x	R/W-x	R/W-x	R/W-x	R/W-x	R/W-x
—	—	HRTEN1	HRTEN0	HRONE3	HRONE2	HRONE1	HRONE0
bit 7							bit 0

### Legend:

R = Readable bit                      W = Writable bit                      U = Unimplemented bit, read as '0'  
 -n = Value at POR                      '1' = Bit is set                      '0' = Bit is cleared                      x = Bit is unknown

- bit 7-6            **Unimplemented:** Read as '0'
- bit 5-4            **HRTEN<1:0>:** Binary Coded Decimal Value of Hour's Tens Digit bits  
Contains a value from 0 to 2.
- bit 3-0            **HRONE<3:0>:** Binary Coded Decimal Value of Hour's Ones Digit bits  
Contains a value from 0 to 9.

**Note 1:** A write to this register is only allowed when RTCWREN = 1.

## REGISTER 15-18: ALRMMIN: ALARM MINUTES VALUE REGISTER

U-0	R/W-x	R/W-x	R/W-x	R/W-x	R/W-x	R/W-x	R/W-x
—	MINTEN2	MINTEN1	MINTEN0	MINONE3	MINONE2	MINONE1	MINONE0
bit 7							bit 0

### Legend:

R = Readable bit                      W = Writable bit                      U = Unimplemented bit, read as '0'  
 -n = Value at POR                      '1' = Bit is set                      '0' = Bit is cleared                      x = Bit is unknown

- bit 7                **Unimplemented:** Read as '0'
- bit 6-4            **MINTEN<2:0>:** Binary Coded Decimal Value of Minute's Tens Digit bits  
Contains a value from 0 to 5.
- bit 3-0            **MINONE<3:0>:** Binary Coded Decimal Value of Minute's Ones Digit bits  
Contains a value from 0 to 9.

## REGISTER 15-19: ALRMSEC: ALARM SECONDS VALUE REGISTER

U-0	R/W-x	R/W-x	R/W-x	R/W-x	R/W-x	R/W-x	R/W-x
—	SECTEN2	SECTEN1	SECTEN0	SECONE3	SECONE2	SECONE1	SECONE0
bit 7							bit 0

### Legend:

R = Readable bit                      W = Writable bit                      U = Unimplemented bit, read as '0'  
 -n = Value at POR                      '1' = Bit is set                      '0' = Bit is cleared                      x = Bit is unknown

- bit 7                **Unimplemented:** Read as '0'
- bit 6-4            **SECTEN<2:0>:** Binary Coded Decimal Value of Second's Tens Digit bits  
Contains a value from 0 to 5.
- bit 3-0            **SECONE<3:0>:** Binary Coded Decimal Value of Second's Ones Digit bits  
Contains a value from 0 to 9.

# PIC18F87J72

## 15.1.4 RTCEN BIT WRITE

An attempt to write to the RTCEN bit while RTCWREN = 0 will be ignored. RTCWREN must be set before a write to RTCEN can take place.

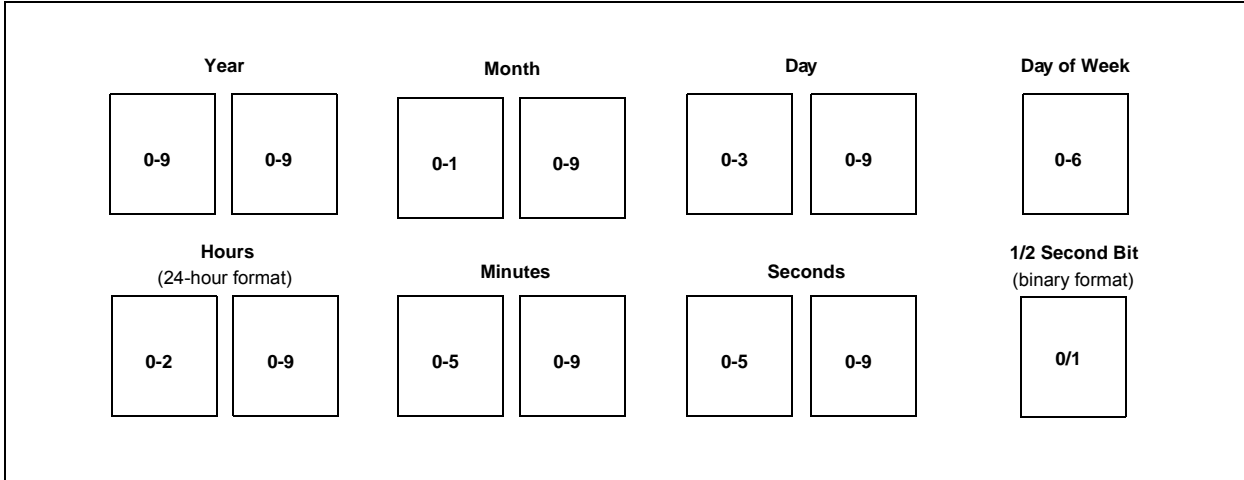
Like the RTCEN bit, the RTCVALH and RTCVALL registers can only be written to when RTCWREN = 1. A write to these registers, while RTCWREN = 0, will be ignored.

## 15.2 Operation

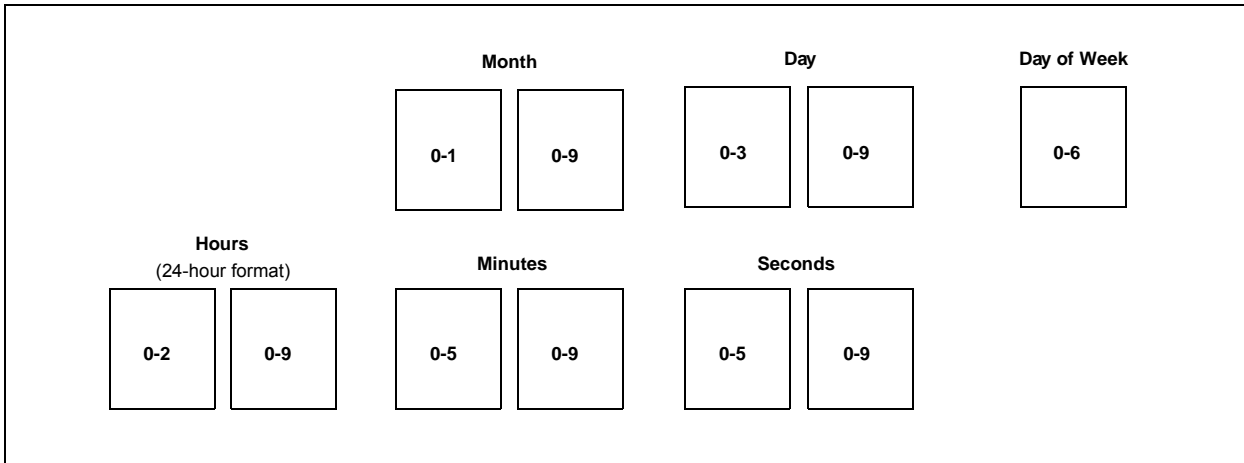
### 15.2.1 REGISTER INTERFACE

The register interface for the RTCC and alarm values is implemented using the Binary Coded Decimal (BCD) format. This simplifies the firmware when using the module, as each of the digits is contained within its own 4-bit value (see [Figure 15-2](#) and [Figure 15-3](#)).

**FIGURE 15-2: TIMER DIGIT FORMAT**



**FIGURE 15-3: ALARM DIGIT FORMAT**



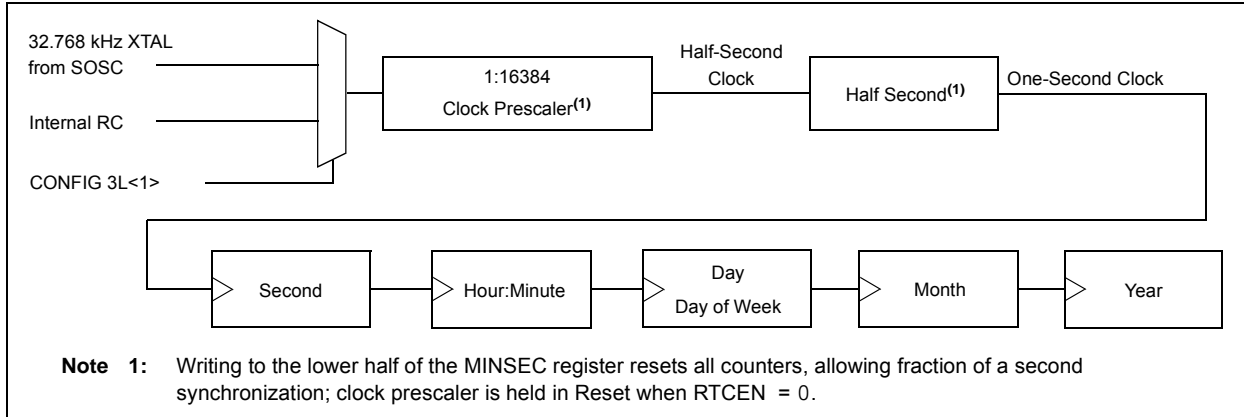


## 15.2.2 CLOCK SOURCE

As mentioned earlier, the RTCC module is intended to be clocked by an external Real-Time Clock crystal oscillating at 32.768 kHz, but can also be an internal oscillator. The RTCC clock selection is decided by the RTCOSC bit (CONFIG3L<1>).

Calibration of the crystal can be done through this module to yield an error of 3 seconds or less per month. (For further details, see [Section 15.2.9 “Calibration”](#).)

**FIGURE 15-4: CLOCK SOURCE MULTIPLEXING**



### 15.2.2.1 Real-Time Clock Enable

The RTCC module can be clocked by an external, 32.768 kHz crystal (Timer1 oscillator) or the internal RC oscillator, which can be selected in CONFIG3L<1>.

If the external clock is used, the Timer1 oscillator should be enabled by setting the T1OSCEN bit (T1CON<3> = 1). If INTRC is providing the clock, the INTRC clock can be brought out to the RTCC pin by the RTSESEL<1:0> bits in the PADCFG register.

## 15.2.3 DIGIT CARRY RULES

This section explains which timer values are affected when there is a rollover.

- Time of Day: from 23:59:59 to 00:00:00 with a carry to the Day field
- Month: from 12/31 to 01/01 with a carry to the Year field
- Day of Week: from 6 to 0 with no carry (see [Table 15-1](#))
- Year Carry: from 99 to 00; this also surpasses the use of the RTCC

For the day to month rollover schedule, see [Table 15-2](#).

Considering that the following values are in BCD format, the carry to the upper BCD digit will occur at a count of 10 and not at 16 (SECONDS, MINUTES, HOURS, WEEKDAY, DAYS and MONTHS).

**TABLE 15-1: DAY OF WEEK SCHEDULE**

Day of Week	
Sunday	0
Monday	1
Tuesday	2
Wednesday	3
Thursday	4
Friday	5
Saturday	6

**TABLE 15-2: DAY TO MONTH ROLLOVER SCHEDULE**

Month	Maximum Day Field
01 (January)	31
02 (February)	28 or 29 <sup>(1)</sup>
03 (March)	31
04 (April)	30
05 (May)	31
06 (June)	30
07 (July)	31
08 (August)	31
09 (September)	30
10 (October)	31
11 (November)	30
12 (December)	31

**Note 1:** See [Section 15.2.4 “Leap Year”](#).

# PIC18F87J72

## 15.2.4 LEAP YEAR

Since the year range on the RTCC module is 2000 to 2099, the leap year calculation is determined by any year divisible by 4 in the above range. Only February is effected in a leap year.

February will have 29 days in a leap year and 28 days in any other year.

## 15.2.5 GENERAL FUNCTIONALITY

All Timer registers containing a time value of seconds or greater are writable. The user configures the time by writing the required year, month, day, hour, minutes and seconds to the Timer registers via register pointers (see [Section 15.2.8 “Register Mapping”](#)).

The timer uses the newly written values and proceeds with the count from the required starting point.

The RTCC is enabled by setting the RTCEN bit (RTCCFG<7>). If enabled while adjusting these registers, the timer still continues to increment. However, any time the MINSEC register is written to, both of the timer prescalers are reset to '0'. This allows fraction of a second synchronization.

The Timer registers are updated in the same cycle as the write instruction's execution by the CPU. The user must ensure that when RTCEN = 1, the updated registers will not be incremented at the same time. This can be accomplished in several ways:

- By checking the RTCSYNC bit (RTCCFG<4>)
- By checking the preceding digits from which a carry can occur
- By updating the registers immediately following the seconds pulse (or alarm interrupt)

The user has visibility to the half-second field of the counter. This value is read-only and can be reset only by writing to the lower half of the SECONDS register.

## 15.2.6 SAFETY WINDOW FOR REGISTER READS AND WRITES

The RTCSYNC bit indicates a time window during which the RTCC clock domain registers can be safely read and written without concern about a rollover. When RTCSYNC = 0, the registers can be safely accessed by the CPU.

Whether RTCSYNC = 1 or 0, the user should employ a firmware solution to ensure that the data read did not fall on a rollover boundary, resulting in an invalid or partial read. This firmware solution would consist of reading each register twice and then comparing the two values. If the two values matched, then a rollover did not occur.

## 15.2.7 WRITE LOCK

In order to perform a write to any of the RTCC Timer registers, the RTCWREN bit (RTCCFG<5>) must be set.

To avoid accidental writes to the RTCC Timer register, it is recommended that the RTCWREN bit (RTCCFG<5>) be kept clear at any time other than while writing to it. For the RTCWREN bit to be set, there is only one instruction cycle time window allowed between the 55h/AA sequence and the setting of RTCWREN. For that reason, it is recommended that users follow the code example in [Example 15-1](#).

### EXAMPLE 15-1: SETTING THE RTCWREN BIT

```
movlw    0x55
movwfm  EECON2
movlw    0xAA
movwfm  EECON2
bsf     RTCCFG, RTCWREN
```

## 15.2.8 REGISTER MAPPING

To limit the register interface, the RTCC Timer and Alarm Timer registers are accessed through corresponding register pointers. The RTCC Value register window (RTCVALH and RTCVALL) uses the RTCPTR bits (RTCCFG<1:0>) to select the required Timer register pair.

By reading or writing to the RTCVALH register, the RTCC Pointer value (RTCPTR<1:0>) decrements by '1' until it reaches '00'. Once it reaches '00', the MINUTES and SECONDS value will be accessible through RTCVALH and RTCVALL until the pointer value is manually changed.

**TABLE 15-3: RTCVALH AND RTCVALL REGISTER MAPPING**

RTCPTR<1:0>	RTCC Value Register Window	
	RTCVALH	RTCVALL
00	MINUTES	SECONDS
01	WEEKDAY	HOURS
10	MONTH	DAY
11	—	YEAR

The Alarm Value register window (ALRMVALH and ALRMVALL) uses the ALRMPTR bits (ALRMCFG<1:0>) to select the desired Alarm register pair.

By reading or writing to the ALRMVALH register, the Alarm Pointer value, ALRMPTR<1:0>, decrements by '1' until it reaches '00'. Once it reaches '00', the ALRMMIN and ALRMSEC value will be accessible through ALRMVALH and ALRMVALL until the pointer value is manually changed.

**TABLE 15-4: ALRMVAL REGISTER MAPPING**

ALRMPTR<1:0>	Alarm Value Register Window	
	ALRMVALH	ALRMVALL
00	ALRMMIN	ALRMSEC
01	ALRMWD	ALRMHR
10	ALRMMNTH	ALRMDAY
11	—	—

## 15.2.9 CALIBRATION

The real-time crystal input can be calibrated using the periodic auto-adjust feature. When properly calibrated, the RTCC can provide an error of less than three seconds per month.

To perform this calibration, find the number of error clock pulses and store the value into the lower half of the RTCCAL register. The 8-bit, signed value, loaded into RTCCAL, is multiplied by 4 and will either be added or subtracted from the RTCC timer, once every minute.

To calibrate the RTCC module:

1. Use another timer resource on the device to find the error of the 32.768 kHz crystal.
2. Convert the number of error clock pulses per minute (see [Equation 15-1](#)).

### EQUATION 15-1: CONVERTING ERROR CLOCK PULSES

$$\frac{(\text{Ideal Frequency (32,758)} - \text{Measured Frequency}) * 60}{\text{Error Clocks per Minute}}$$

- If the oscillator is *faster* than ideal (negative result from step 2), the RCFGCALL register value needs to be negative. This causes the specified number of clock pulses to be subtracted from the timer counter once every minute.
  - If the oscillator is *slower* than ideal (positive result from step 2), the RCFGCALL register value needs to be positive. This causes the specified number of clock pulses to be added to the timer counter once every minute.
3. Load the RTCCAL register with the correct value.

Writes to the RTCCAL register should occur only when the timer is turned off, or immediately after the rising edge of the seconds pulse.

**Note:** In determining the crystal's error value, it is the user's responsibility to include the crystal's initial error from drift due to temperature or crystal aging.

## 15.3 Alarm

The Alarm features and characteristics are:

- Configurable from half a second to one year
- Enabled using the ALRMEN bit (ALRMCFG<7>, [Register 15-4](#))
- Offers one-time and repeat alarm options

### 15.3.1 CONFIGURING THE ALARM

The alarm feature is enabled using the ALRMEN bit.

This bit is cleared when an alarm is issued. The bit will not be cleared if the CHIME bit = 1 or if ALMRPT ≠ 0.

The interval selection of the alarm is configured through the ALRMCFG bits (AMASK<3:0>). (See [Figure 15-5](#).) These bits determine which and how many digits of the alarm must match the clock value for the alarm to occur.

The alarm can also be configured to repeat based on a preconfigured interval. The number of times this occurs, after the alarm is enabled, is stored in the ALMRPT register.

**Note:** While the alarm is enabled (ALRMEN = 1), changing any of the registers, other than the RTCCAL, ALRMCFG and ALMRPT registers, and the CHIME bit, can result in a false alarm event leading to a false alarm interrupt. To avoid this, only change the timer and alarm values while the alarm is disabled (ALRMEN = 0). It is recommended that the ALRMCFG and ALMRPT registers and CHIME bit be changed when RTCSYNC = 0.

# PIC18F87J72

**FIGURE 15-5: ALARM MASK SETTINGS**

Alarm Mask Setting AMASK<3:0>	Day of the Week	Month	Day	Hours	Minutes	Seconds
0000 – Every half second	<input type="checkbox"/>	<input type="checkbox"/> <input type="checkbox"/>	/ <input type="checkbox"/> <input type="checkbox"/>	<input type="checkbox"/> <input type="checkbox"/> :	<input type="checkbox"/> <input type="checkbox"/> :	<input type="checkbox"/> <input type="checkbox"/>
0001 – Every second	<input type="checkbox"/>	<input type="checkbox"/> <input type="checkbox"/>	/ <input type="checkbox"/> <input type="checkbox"/>	<input type="checkbox"/> <input type="checkbox"/> :	<input type="checkbox"/> <input type="checkbox"/> :	<input type="checkbox"/> <input type="checkbox"/>
0010 – Every 10 seconds	<input type="checkbox"/>	<input type="checkbox"/> <input type="checkbox"/>	/ <input type="checkbox"/> <input type="checkbox"/>	<input type="checkbox"/> <input type="checkbox"/> :	<input type="checkbox"/> <input type="checkbox"/> :	<input type="checkbox"/> <b>s</b>
0011 – Every minute	<input type="checkbox"/>	<input type="checkbox"/> <input type="checkbox"/>	/ <input type="checkbox"/> <input type="checkbox"/>	<input type="checkbox"/> <input type="checkbox"/> :	<input type="checkbox"/> <input type="checkbox"/> :	<b>s</b> <b>s</b>
0100 – Every 10 minutes	<input type="checkbox"/>	<input type="checkbox"/> <input type="checkbox"/>	/ <input type="checkbox"/> <input type="checkbox"/>	<input type="checkbox"/> <input type="checkbox"/> :	<input type="checkbox"/> <b>m</b> :	<b>s</b> <b>s</b>
0101 – Every hour	<input type="checkbox"/>	<input type="checkbox"/> <input type="checkbox"/>	/ <input type="checkbox"/> <input type="checkbox"/>	<input type="checkbox"/> <input type="checkbox"/> :	<b>m</b> <b>m</b> :	<b>s</b> <b>s</b>
0110 – Every day	<input type="checkbox"/>	<input type="checkbox"/> <input type="checkbox"/>	/ <input type="checkbox"/> <input type="checkbox"/>	<b>h</b> <b>h</b> :	<b>m</b> <b>m</b> :	<b>s</b> <b>s</b>
0111 – Every week	<b>d</b>	<input type="checkbox"/> <input type="checkbox"/>	/ <input type="checkbox"/> <input type="checkbox"/>	<b>h</b> <b>h</b> :	<b>m</b> <b>m</b> :	<b>s</b> <b>s</b>
1000 – Every month	<input type="checkbox"/>	<input type="checkbox"/> <input type="checkbox"/>	/ <b>d</b> <b>d</b>	<b>h</b> <b>h</b> :	<b>m</b> <b>m</b> :	<b>s</b> <b>s</b>
1001 – Every year <sup>(1)</sup>	<input type="checkbox"/>	<b>m</b> <b>m</b>	/ <b>d</b> <b>d</b>	<b>h</b> <b>h</b> :	<b>m</b> <b>m</b> :	<b>s</b> <b>s</b>

**Note 1:** Annually, except when configured for February 29.

When ALRMCFG = 00 and the CHIME bit = 0 (ALRMCFG<6>), the repeat function is disabled and only a single alarm will occur. The alarm can be repeated up to 255 times by loading the ALRMRPT register with FFh.

After each alarm is issued, the ALRMRPT register is decremented by one. Once the register has reached '00', the alarm will be issued one last time.

After the alarm is issued a last time, the ALRMEN bit is cleared automatically and the alarm turned off. Indefinite repetition of the alarm can occur if the CHIME bit = 1.

When CHIME = 1, the alarm is not disabled when the ALRMRPT register reaches '00', but it rolls over to FF and continues counting indefinitely.

## 15.3.2 ALARM INTERRUPT

At every alarm event, an interrupt is generated. Additionally, an alarm pulse output is provided that operates at half the frequency of the alarm.

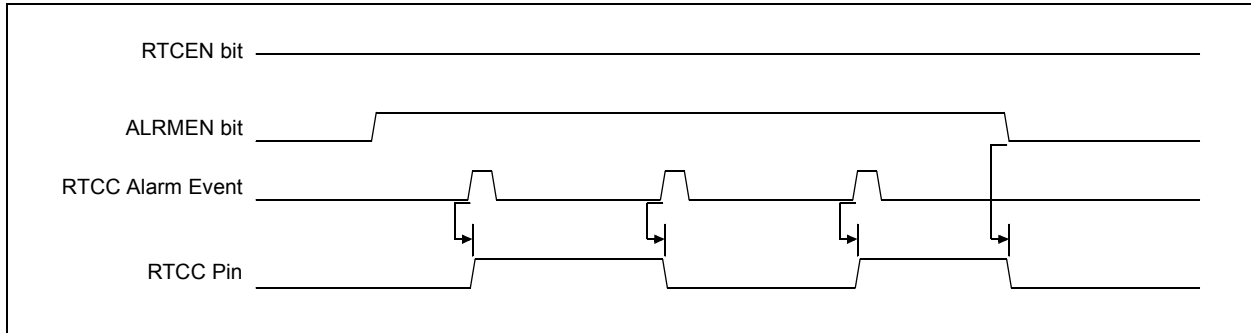
The alarm pulse output is completely synchronous with the RTCC clock and can be used as a trigger clock to other peripherals. This output is available on the RTCC pin. The output pulse is a clock with a 50% duty cycle and a frequency half that of the alarm event (see Figure 15-6).

The RTCC pin can also output the seconds clock. The user can select between the alarm pulse, generated by the RTCC module, or the seconds clock output.

The RTSECSEL<1:0> (PADCFG1<2:1>) bits select between these two outputs:

- Alarm Pulse – RTSECSEL<1:0> = 00
- Seconds Clock – RTSECSEL<1:0> = 01

**FIGURE 15-6: TIMER PULSE GENERATION**



## 15.4 Sleep Mode

The timer and alarm continue to operate while in Sleep mode. The operation of the alarm is not affected by Sleep as an alarm event can always wake-up the CPU.

The Idle mode does not affect the operation of the timer or alarm.

## 15.5 Reset

### 15.5.1 DEVICE RESET

When a device Reset occurs, the ALCFGRPT register is forced to its Reset state, causing the alarm to be disabled (if enabled prior to the Reset). If the RTCC was enabled, it will continue to operate when a basic device Reset occurs.

### 15.5.2 POWER-ON RESET (POR)

The RTCCFG and ALMRPT registers are reset only on a POR. Once the device exits the POR state, the clock registers should be reloaded with the desired values.

The timer prescaler values can be reset only by writing to the SECONDS register. No device Reset can affect the prescalers.

# PIC18F87J72

## 15.6 Register Maps

Table 15-5, Table 15-6 and Table 15-7 summarize the registers associated with the RTCC module.

**TABLE 15-5: RTCC CONTROL REGISTERS**

File Name	Bit 7	Bit 6	Bit 5	Bit 4	Bit 3	Bit 2	Bit 1	Bit 0	All Resets on Page
RTCCFG	RTCEN	—	RTCWREN	RTCSYNC	HALFSEC	RTCOE	RTCPTR1	RTCPTR0	50
RTCCAL	CAL7	CAL6	CAL5	CAL4	CAL3	CAL2	CAL1	CAL0	50
PADCFG1	—	—	—	—	—	RTSECSEL1	RTSECSEL0	—	50
ALRMCFG	ALRMEN	CHIME	AMASK3	AMASK2	AMASK1	AMASK0	ALRMPTR1	ALRMPTR0	50
ALMRPT	ARPT7	ARPT6	ARPT5	ARPT4	ARPT3	ARPT2	ARPT1	ARPT0	50

Legend: — = unimplemented, read as '0'. Reset values are shown in hexadecimal for 80-pin devices.

**TABLE 15-6: RTCC VALUE REGISTERS**

File Name	Bit 7	Bit 6	Bit 5	Bit 4	Bit 3	Bit 2	Bit 1	Bit 0	All Resets on Page
RTCVALH	RTCC Value High Register Window Based on RTCPTR<1:0>								50
RTCVALL	RTCC Value Low Register Window Based on RTCPTR<1:0>								50

Legend: — = unimplemented, read as '0'. Reset values are shown in hexadecimal for 80-pin devices.

**TABLE 15-7: ALARM VALUE REGISTERS**

File Name	Bit 7	Bit 6	Bit 5	Bit 4	Bit 3	Bit 2	Bit 1	Bit 0	All Resets on Page
ALRMVALH	Alarm Value High Register Window Based on ALRMPTR<1:0>								50
ALRMVALL	Alarm Value Low Register Window Based on ALRMPTR<1:0>								50

Legend: — = unimplemented, read as '0'. Reset values are shown in hexadecimal for 80-pin devices.

## 16.0 CAPTURE/COMPARE/PWM (CCP) MODULES

PIC18F87J72 family devices have two CCP (Capture/Compare/PWM) modules, designated CCP1 and CCP2. Both modules implement standard capture, compare and Pulse-Width Modulation (PWM) modes.

Each CCP module contains two 8-bit registers that can operate as two 8-bit Capture registers, two 8-bit Compare registers or two PWM Master/Slave Duty Cycle registers. For the sake of clarity, all CCP module operation in the following sections is described with respect to CCP2, but is equally applicable to CCP1.

**REGISTER 16-1: CCPxCON: CCPx CONTROL REGISTER (CCP1, CCP2 MODULES)**

U-0	U-0	R/W-0	R/W-0	R/W-0	R/W-0	R/W-0	R/W-0
—	—	DCxB1	DCxB0	CCPxM3	CCPxM2	CCPxM1	CCPxM0
bit 7							bit 0

**Legend:**

R = Readable bit	W = Writable bit	U = Unimplemented bit, read as '0'
-n = Value at POR	'1' = Bit is set	'0' = Bit is cleared
		x = Bit is unknown

bit 7-6 **Unimplemented:** Read as '0'

bit 5-4 **DCxB<1:0>:** PWM Duty Cycle bit 1 and bit 0 for CCPx Module

Capture mode:

Unused.

Compare mode:

Unused.

PWM mode:

These bits are the two Least Significant bits (bit 1 and bit 0) of the 10-bit PWM duty cycle. The eight Most Significant bits (DCx<9:2>) of the duty cycle are found in CCPRxL.

bit 3-0 **CCPxM<3:0>:** CCPx Module Mode Select bits

0000 =Capture/Compare/PWM disabled (resets CCPx module)

0001 =Reserved

0010 =Compare mode, toggle output on match (CCPxIF bit is set)

0011 =Reserved

0100 =Capture mode, every falling edge

0101 =Capture mode, every rising edge

0110 =Capture mode, every 4th rising edge

0111 =Capture mode, every 16th rising edge

1000 =Compare mode: initialize CCPx pin low; on compare match, force CCPx pin high (CCPxIF bit is set)

1001 =Compare mode: initialize CCPx pin high; on compare match, force CCPx pin low (CCPxIF bit is set)

1010 =Compare mode: generate software interrupt on compare match (CCPxIF bit is set, CCPx pin reflects I/O state)

1011 =Compare mode: Special Event Trigger; reset timer; start A/D conversion on CCPx match (CCPxIF bit is set)<sup>(1)</sup>

11xx =PWM mode

**Note 1:** CCPxM<3:0> = 1011 will only reset the timer and not start an A/D conversion on a CCP1 match.

# PIC18F87J72

## 16.1 CCP Module Configuration

Each Capture/Compare/PWM module is associated with a control register (generally, CCPxCON) and a data register (CCPRx). The data register, in turn, is comprised of two 8-bit registers: CCPRxL (low byte) and CCPRxH (high byte). All registers are both readable and writable.

### 16.1.1 CCP MODULES AND TIMER RESOURCES

The CCP modules utilize timers, 1, 2 or 3, depending on the mode selected. Timer1 and Timer3 are available to modules in Capture or Compare modes, while Timer2 is available for modules in PWM mode.

**TABLE 16-1: CCP MODE – TIMER RESOURCE**

CCP Mode	Timer Resource
Capture	Timer1 or Timer3
Compare	Timer1 or Timer3
PWM	Timer2

The assignment of a particular timer to a module is determined by the Timer to CCP enable bits in the T3CON register (Register 14-1). Both modules may be active at any given time and may share the same timer resource if they are configured to operate in the same mode (Capture/Compare or PWM) at the same time. The interactions between the two modules are summarized in Table 16-2.

Depending on the configuration selected, up to four timers may be active at once, with modules in the same configuration (Capture/Compare or PWM) sharing timer resources. The possible configurations are shown in Figure 16-1.

### 16.1.2 OPEN-DRAIN OUTPUT OPTION

When operating in Output mode (i.e., in Compare or PWM modes), the drivers for the CCPx pins can be optionally configured as open-drain outputs. This feature allows the voltage level on the pin to be pulled to a higher level through an external pull-up resistor and allows the output to communicate with external circuits without the need for additional level shifters.

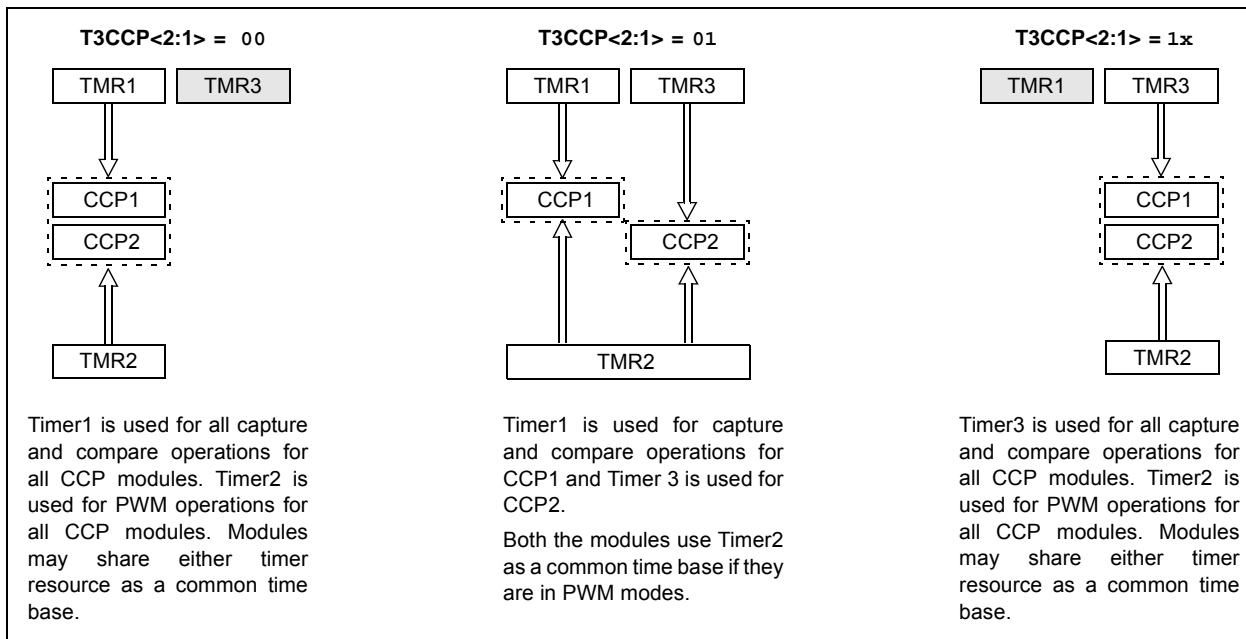
The open-drain output option is controlled by the CCP2OD and CCP1OD bits (TRISG<6:5>). Setting the appropriate bit configures the pin for the corresponding module for open-drain operation.

### 16.1.3 CCP2 PIN ASSIGNMENT

The pin assignment for CCP2 (capture input, compare and PWM output) can change, based on device configuration. The CCP2MX Configuration bit determines which pin CCP2 is multiplexed to. By default, it is assigned to RC1 (CCP2MX = 1). If the Configuration bit is cleared, CCP2 is multiplexed with RE7.

Changing the pin assignment of CCP2 does not automatically change any requirements for configuring the port pin. Users must always verify that the appropriate TRIS register is configured correctly for CCP2 operation, regardless of where it is located.

**FIGURE 16-1: CCP AND TIMER INTERCONNECT CONFIGURATIONS**





**TABLE 16-2: INTERACTIONS BETWEEN CCP1 AND CCP2 FOR TIMER RESOURCES**

CCP1 Mode	CCP2 Mode	Interaction
Capture	Capture	Each module can use TMR1 or TMR3 as the time base. The time base can be different for each CCP.
Capture	Compare	CCP2 can be configured for the Special Event Trigger to reset TMR1 or TMR3 (depending upon which time base is used). Automatic A/D conversions on trigger event can also be done. Operation of CCP1 could be affected if it is using the same timer as a time base.
Compare	Capture	CCP1 can be configured for the Special Event Trigger to reset TMR1 or TMR3 (depending upon which time base is used). Operation of CCP2 could be affected if it is using the same timer as a time base.
Compare	Compare	Either module can be configured for the Special Event Trigger to reset the time base. Automatic A/D conversions on CCP2 trigger event can be done. Conflicts may occur if both modules are using the same time base.
Capture	PWM	None
Compare	PWM	None
PWM	Capture	None
PWM	Compare	None
PWM	PWM	Both PWMs will have the same frequency and update rate (TMR2 interrupt).

# PIC18F87J72

## 16.2 Capture Mode

In Capture mode, the CCPR2H:CCPR2L register pair captures the 16-bit value of the TMR1 or TMR3 register when an event occurs on the CCP2 pin (RC1 or RE7, depending on device configuration). An event is defined as one of the following:

- Every falling edge
- Every rising edge
- Every 4th rising edge
- Every 16th rising edge

The event is selected by the mode select bits, CCP2M<3:0> (CCP2CON<3:0>). When a capture is made, the interrupt request flag bit, CCP2IF (PIR3<2>), is set; it must be cleared in software. If another capture occurs before the value in register, CCPR2, is read, the old captured value is overwritten by the new captured value.

### 16.2.1 CCP PIN CONFIGURATION

In Capture mode, the appropriate CCPx pin should be configured as an input by setting the corresponding TRIS direction bit.

**Note:** If RC1/CCP2 or RE7/CCP2 is configured as an output, a write to the port can cause a capture condition.

### 16.2.2 TIMER1/TIMER3 MODE SELECTION

The timers that are to be used with the capture feature (Timer1 and/or Timer3) must be running in Timer mode or Synchronized Counter mode. In Asynchronous Counter mode, the capture operation may not work. The timer to be used with each CCP module is selected in the T3CON register (see [Section 16.1.1 “CCP Modules and Timer Resources”](#)).

### 16.2.3 SOFTWARE INTERRUPT

When the Capture mode is changed, a false capture interrupt may be generated. The user should keep the CCP2IE bit (PIE3<2>) clear to avoid false interrupts and should clear the flag bit, CCP2IF, following any such change in operating mode.

### 16.2.4 CCP PRESCALER

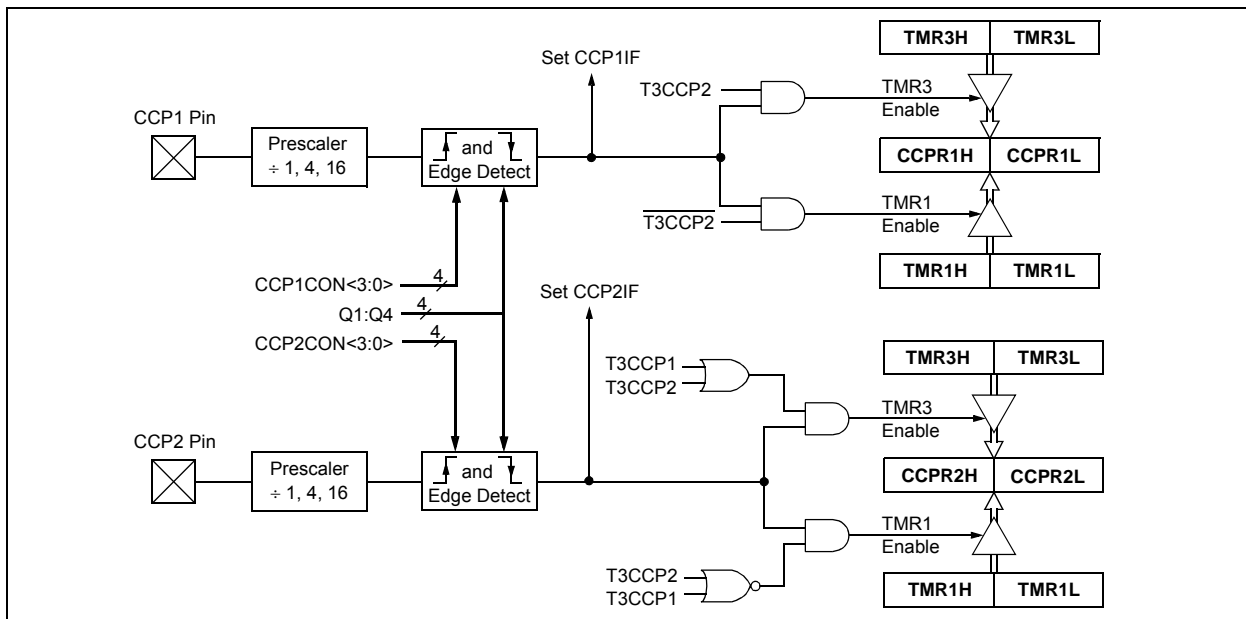
There are four prescaler settings in Capture mode. They are specified as part of the operating mode selected by the mode select bits (CCP2M<3:0>). Whenever the CCP module is turned off, or the CCP module is not in Capture mode, the prescaler counter is cleared. This means that any Reset will clear the prescaler counter.

Switching from one capture prescaler to another may generate an interrupt. Also, the prescaler counter will not be cleared; therefore, the first capture may be from a non-zero prescaler. [Example 16-1](#) shows the recommended method for switching between capture prescalers. This example also clears the prescaler counter and will not generate the “false” interrupt.

#### EXAMPLE 16-1: CHANGING BETWEEN CAPTURE PRESCALERS

```
CLRFFCCP2CON; Turn CCP module off
MOVLWNEW_CAPT_PS; Load WREG with the
                ; new prescaler mode
                ; value and CCP ON
MOVWFCCP2CON; Load CCP2CON with
                ; this value
```

**FIGURE 16-2: CAPTURE MODE OPERATION BLOCK DIAGRAM**



## 16.3 Compare Mode

In Compare mode, the 16-bit CCPR2 register value is constantly compared against either the TMR1 or TMR3 register pair value. When a match occurs, the CCP2 pin can be:

- driven high
- driven low
- toggled (high-to-low or low-to-high)
- remain unchanged (that is, reflects the state of the I/O latch)

The action on the pin is based on the value of the mode select bits (CCP2M<3:0>). At the same time, the interrupt flag bit, CCP2IF, is set.

### 16.3.1 CCP PIN CONFIGURATION

The user must configure the CCPx pin as an output by clearing the appropriate TRIS bit.

**Note:** Clearing the CCP2CON register will force the RC1 or RE7 compare output latch (depending on device configuration) to the default low level. This is not the PORTC or PORTE I/O data latch.

### 16.3.2 TIMER1/TIMER3 MODE SELECTION

Timer1 and/or Timer3 must be running in Timer mode, or Synchronized Counter mode, if the CCP module is using the compare feature. In Asynchronous Counter mode, the compare operation may not work.

### 16.3.3 SOFTWARE INTERRUPT MODE

When the Generate Software Interrupt mode is chosen (CCP2M<3:0> = 1010), the CCP2 pin is not affected. Only a CCP interrupt is generated, if enabled, and the CCP2IE bit is set.

### 16.3.4 SPECIAL EVENT TRIGGER

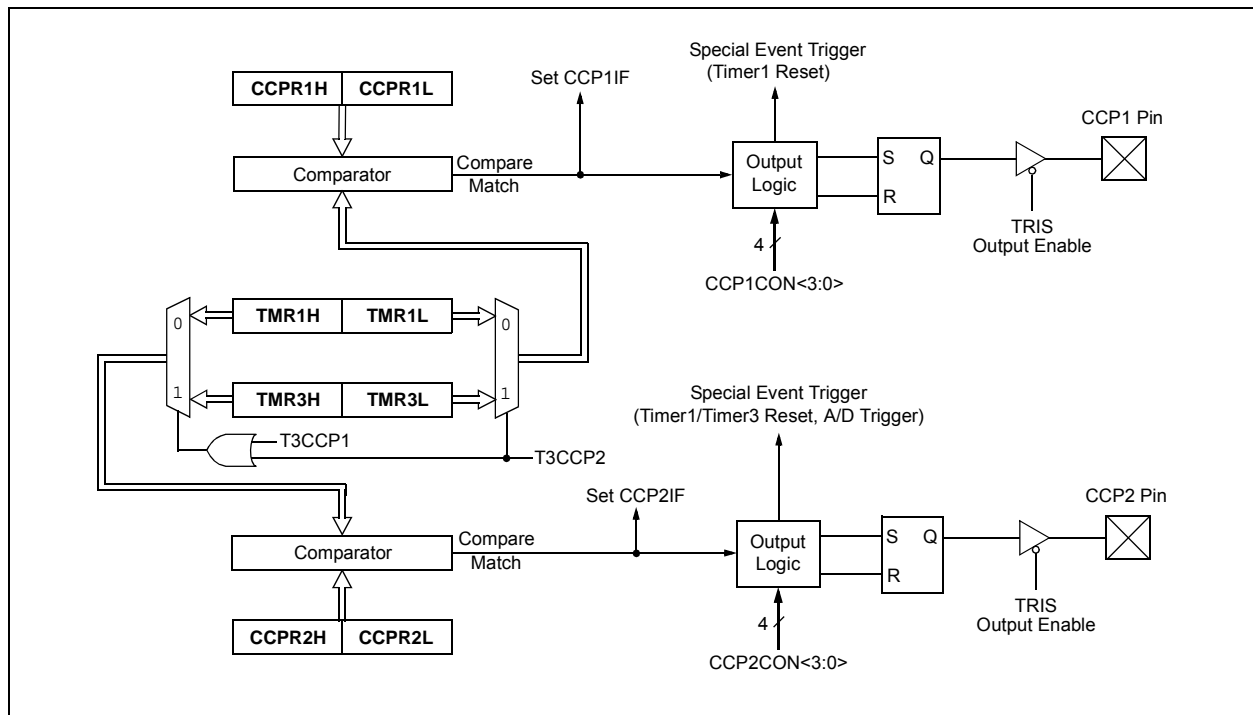
Both CCP modules are equipped with a Special Event Trigger. This is an internal hardware signal generated in Compare mode to trigger actions by other modules. The Special Event Trigger is enabled by selecting the Compare Special Event Trigger mode (CCP2M<3:0> = 1011).

For either CCP module, the Special Event Trigger resets the Timer register pair for whichever timer resource is currently assigned as the module's time base. This allows the CCPRx registers to serve as a programmable period register for either timer.

The Special Event Trigger for CCP2 can also start an A/D conversion. In order to do this, the A/D Converter must already be enabled.

**Note:** The Special Event Trigger of CCP1 only resets Timer1/Timer3 and cannot start an A/D conversion even when the A/D Converter is enabled.

**FIGURE 16-3: COMPARE MODE OPERATION BLOCK DIAGRAM**



# PIC18F87J72

**TABLE 16-3: REGISTERS ASSOCIATED WITH CAPTURE, COMPARE, TIMER1 AND TIMER3**

Name	Bit 7	Bit 6	Bit 5	Bit 4	Bit 3	Bit 2	Bit 1	Bit 0	Reset Values on Page
INTCON	GIE/GIEH	PEIE/GIEL	TMR0IE	INT0IE	RBIE	TMR0IF	INT0IF	RBIF	45
RCON	IPEN	—	CM	RI	TO	PD	POR	BOR	46
PIR3	—	LCDIF	RC2IF	TX2IF	CTMUIF	CCP2IF	CCP1IF	RTCCIF	48
PIE3	—	LCDIE	RC2IE	TX2IE	CTMUIE	CCP2IE	CCP1IE	RTCCIE	48
IPR3	—	LCDIP	RC2IP	TX2IP	CTMUIP	CCP2IP	CCP1IP	RTCCIP	48
PIR2	OSCFIF	CMIF	—	—	BCLIF	LVDIF	TMR3IF	—	48
PIE2	OSCFIE	CMIE	—	—	BCLIE	LVDIE	TMR3IE	—	48
IPR2	OSCFIP	CMIP	—	—	BCLIP	LVDIP	TMR3IP	—	48
TRISC	TRISC7	TRISC6	TRISC5	TRISC4	TRISC3	TRISC2	TRISC1	TRISC0	48
TRISE	TRISE7	TRISE6	TRISE5	TRISE4	TRISE3	—	TRISE1	TRISE0	48
TRISG	SPIOD	CCP2OD	CCP1OD	TRISG4	TRISG3	TRISG2	TRISG1	TRISG0	48
TMR1L	Timer1 Register Low Byte								46
TMR1H	Timer1 Register High Byte								46
T1CON	RD16	T1RUN	T1CKPS1	T1CKPS0	T1OSCEN	T1SYNC	TMR1CS	TMR1ON	46
TMR3H	Timer3 Register High Byte								47
TMR3L	Timer3 Register Low Byte								47
T3CON	RD16	T3CCP2	T3CKPS1	T3CKPS0	T3CCP1	T3SYNC	TMR3CS	TMR3ON	47
CCPR1L	Capture/Compare/PWM Register 1 Low Byte								49
CCPR1H	Capture/Compare/PWM Register 1 High Byte								49
CCP1CON	—	—	DC1B1	DC1B0	CCP1M3	CCP1M2	CCP1M1	CCP1M0	49
CCPR2L	Capture/Compare/PWM Register 2 Low Byte								49
CCPR2H	Capture/Compare/PWM Register 2 High Byte								49
CCP2CON	—	—	DC2B1	DC2B0	CCP2M3	CCP2M2	CCP2M1	CCP2M0	49

Legend: — = unimplemented, read as '0'. Shaded cells are not used by Capture/Compare, Timer1 or Timer3.

## 16.4 PWM Mode

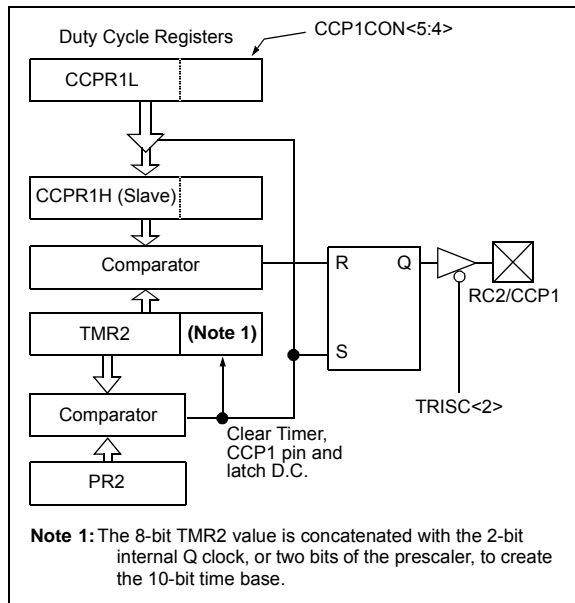
In Pulse-Width Modulation (PWM) mode, the CCP2 pin produces up to a 10-bit resolution PWM output. Since the CCP2 pin is multiplexed with a PORTC or PORTE data latch, the appropriate TRIS bit must be cleared to make the CCP2 pin an output.

**Note:** Clearing the CCP2CON register will force the RC1 or RE7 output latch (depending on device configuration) to the default low level. This is not the PORTC or PORTE I/O data latch.

Figure 16-4 shows a simplified block diagram of the CCP1 module in PWM mode.

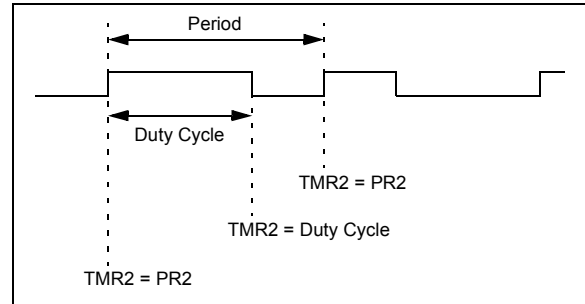
For a step-by-step procedure on how to set up the CCP module for PWM operation, see Section 16.4.3 “Setup for PWM Operation”.

**FIGURE 16-4: SIMPLIFIED PWM BLOCK DIAGRAM**



A PWM output (Figure 16-5) has a time base (period) and a time that the output stays high (duty cycle). The frequency of the PWM is the inverse of the period (1/period).

**FIGURE 16-5: PWM OUTPUT**



### 16.4.1 PWM PERIOD

The PWM period is specified by writing to the PR2 register. The PWM period can be calculated using the following formula:

**EQUATION 16-1:**

$$\text{PWM Period} = (\text{PR2} + 1) \cdot 4 \cdot \text{Tosc} \cdot (\text{TMR2 Prescale Value})$$

PWM frequency is defined as 1/[PWM period].

When TMR2 is equal to PR2, the following three events occur on the next increment cycle:

- TMR2 is cleared
- The CCP2 pin is set (exception: if PWM duty cycle = 0%, the CCP2 pin will not be set)
- The PWM duty cycle is latched from CCPR2L into CCPR2H

**Note:** The Timer2 postscalers (see Section 13.0 “Timer2 Module”) are not used in the determination of the PWM frequency. The postscaler could be used to have a servo update rate at a different frequency than the PWM output.

# PIC18F87J72

## 16.4.2 PWM DUTY CYCLE

The PWM duty cycle is specified by writing to the CCPR2L register and to the CCP2CON<5:4> bits. Up to 10-bit resolution is available. The CCPR2L contains the eight MSbs and the CCP2CON<5:4> bits contain the two LSbs. This 10-bit value is represented by CCPR2L:CCP2CON<5:4>. The following equation is used to calculate the PWM duty cycle in time:

### EQUATION 16-2:

$$\text{PWM Duty Cycle} = (\text{CCPR2L:CCP2CON<5:4>}) \cdot \text{Tosc} \cdot (\text{TMR2 Prescale Value})$$

CCPR2L and CCP2CON<5:4> can be written to at any time, but the duty cycle value is not latched into CCPR2H until after a match between PR2 and TMR2 occurs (i.e., the period is complete). In PWM mode, CCPR2H is a read-only register.

The CCPR2H register and a 2-bit internal latch are used to double-buffer the PWM duty cycle. This double-buffering is essential for glitchless PWM operation.

When the CCPR2H and 2-bit latch match TMR2, concatenated with an internal 2-bit Q clock or two bits of the TMR2 prescaler, the CCP2 pin is cleared.

The maximum PWM resolution (bits) for a given PWM frequency is given by the equation:

### EQUATION 16-3:

$$\text{PWM Resolution (max)} = \frac{\log\left(\frac{F_{\text{OSC}}}{F_{\text{PWM}}}\right)}{\log(2)} \text{ bits}$$

**Note:** If the PWM duty cycle value is longer than the PWM period, the CCP2 pin will not be cleared.

**TABLE 16-4: EXAMPLE PWM FREQUENCIES AND RESOLUTIONS AT 40 MHz**

PWM Frequency	2.44 kHz	9.77 kHz	39.06 kHz	156.25 kHz	312.50 kHz	416.67 kHz
Timer Prescaler (1, 4, 16)	16	4	1	1	1	1
PR2 Value	FFh	FFh	FFh	3Fh	1Fh	17h
Maximum Resolution (bits)	14	12	10	8	7	6.58

## 16.4.3 SETUP FOR PWM OPERATION

The following steps should be taken when configuring the CCP module for PWM operation:

1. Set the PWM period by writing to the PR2 register.
2. Set the PWM duty cycle by writing to the CCPR2L register and CCP2CON<5:4> bits.
3. Make the CCP2 pin an output by clearing the appropriate TRIS bit.
4. Set the TMR2 prescale value, then enable Timer2 by writing to T2CON.
5. Configure the CCP2 module for PWM operation.

**TABLE 16-5: REGISTERS ASSOCIATED WITH PWM AND TIMER2**

Name	Bit 7	Bit 6	Bit 5	Bit 4	Bit 3	Bit 2	Bit 1	Bit 0	Reset Values on Page
INTCON	GIE/GIEH	PEIE/GIEL	TMR0IE	INT0IE	RBIE	TMR0IF	INT0IF	RBIF	45
RCON	IPEN	—	$\overline{CM}$	$\overline{RI}$	$\overline{TO}$	$\overline{PD}$	$\overline{POR}$	$\overline{BOR}$	46
PIR1	—	ADIF	RC1IF	TX1IF	SSPIF	—	TMR2IF	TMR1IF	48
PIE1	—	ADIE	RC1IE	TX1IE	SSPIE	—	TMR2IE	TMR1IE	48
IPR1	—	ADIP	RC1IP	TX1IP	SSPIP	—	TMR2IP	TMR1IP	48
TRISC	TRISC7	TRISC6	TRISC5	TRISC4	TRISC3	TRISC2	TRISC1	TRISC0	48
TRISE	TRISE7	TRISE6	TRISE5	TRISE4	TRISE3	—	TRISE1	TRISE0	48
TRISG	SPIOD	CCP2OD	CCP1OD	TRISG4	TRISG3	TRISG2	TRISG1	TRISG0	48
TMR2	Timer2 Register								46
PR2	Timer2 Period Register								46
T2CON	—	T2OUTPS3	T2OUTPS2	T2OUTPS1	T2OUTPS0	TMR2ON	T2CKPS1	T2CKPS0	46
CCPR1L	Capture/Compare/PWM Register 1 Low Byte								49
CCPR1H	Capture/Compare/PWM Register 1 High Byte								49
CCP1CON	—	—	DC1B1	DC1B0	CCP1M3	CCP1M2	CCP1M1	CCP1M0	49
CCPR2L	Capture/Compare/PWM Register 2 Low Byte								49
CCPR2H	Capture/Compare/PWM Register 2 High Byte								49
CCP2CON	—	—	DC2B1	DC2B0	CCP2M3	CCP2M2	CCP2M1	CCP2M0	49

Legend: — = unimplemented, read as '0'. Shaded cells are not used by PWM or Timer2.

# PIC18F87J72

## 17.0 LIQUID CRYSTAL DISPLAY (LCD) DRIVER MODULE

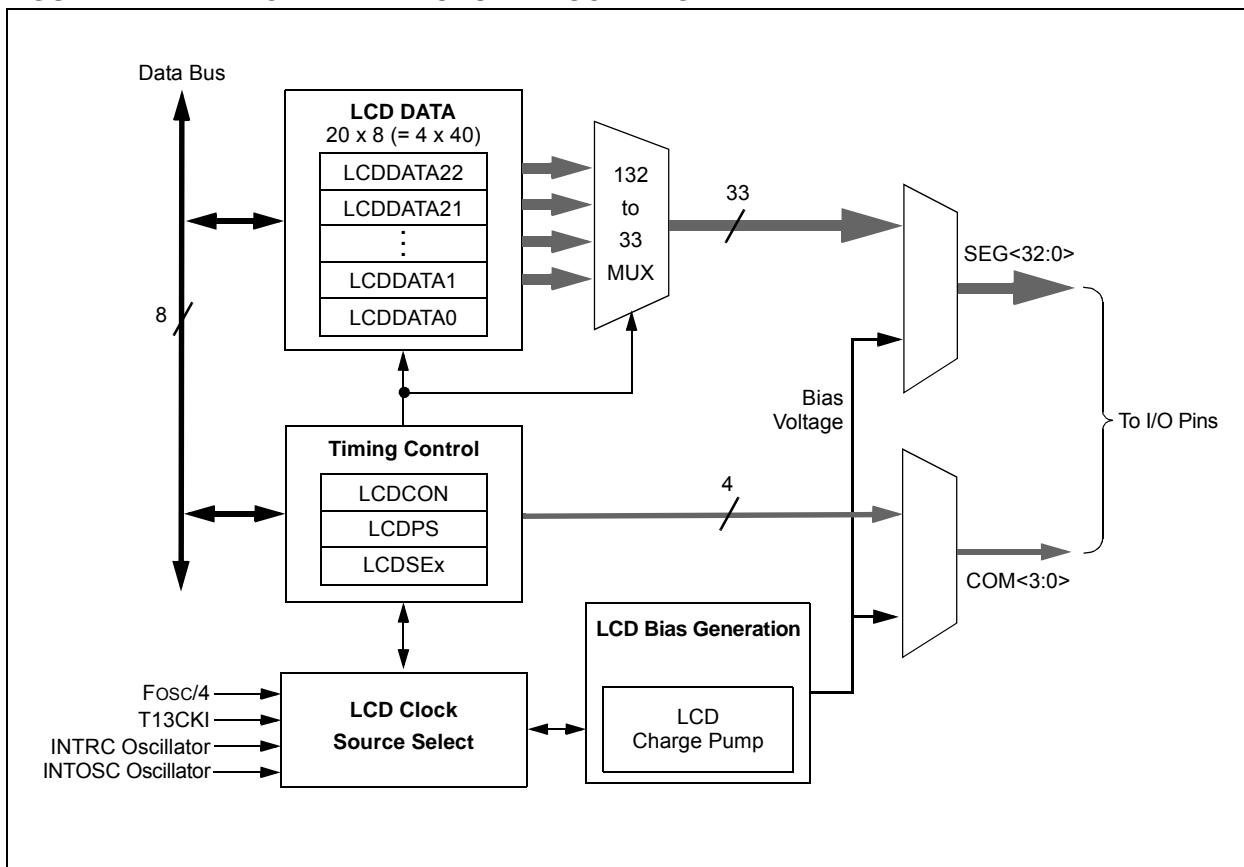
The Liquid Crystal Display (LCD) driver module generates the timing control to drive a static or multiplexed LCD panel. It also provides control of the LCD pixel data. The module can drive panels of up to 132 pixels (33 segments by four commons).

The LCD driver module supports these features:

- Direct driving of LCD panel
- On-chip bias generator with dedicated charge pump to support a range of fixed and variable bias options
- Up to four commons, with four Multiplexing modes
- Up to 33 segments
- Three LCD clock sources with selectable prescaler, with a fourth source available for use with the LCD charge pump

A simplified block diagram of the module is shown in Figure 17-1.

FIGURE 17-1: LCD DRIVER MODULE BLOCK DIAGRAM





## 17.1 LCD Registers

The LCD driver module has 33 registers:

- LCD Control Register (LCDCON)
- LCD Phase Register (LCDPS)
- LCDREG Register (LCD Regulator Control)
- Five LCD Segment Enable Registers (LCDSE4:LCDSE0)
- 20 LCD Data Registers (LCDDATAx, for x from 0 to 22, with 5, 11 and 17 not implemented)

### 17.1.1 LCD CONTROL REGISTERS

The LCDCON register, shown in [Register 17-1](#), controls the overall operation of the module. Once the module is configured, the LCDEN (LCDCON<7>) bit is used to enable or disable the LCD module. The LCD panel can also operate during Sleep by clearing the SLPEN (LCDCON<6>) bit.

The LCDPS register, shown in [Register 17-2](#), configures the LCD clock source prescaler and the type of waveform: Type-A or Type-B. Details on these features are provided in [Section 17.2 “LCD Clock Source”](#), [Section 17.3 “LCD Bias Generation”](#) and [Section 17.8 “LCD Waveform Generation”](#).

The LCDREG register is described in [Section 17.3 “LCD Bias Generation”](#).

The LCD Segment Enable registers (LCDSEx) configure the functions of the port pins. Setting the segment enable bit for a particular segment configures that pin as an LCD driver. The prototype LCDSE register is shown in [Register 17-3](#). There are five LCDSE registers (LCDSE4:LCDSE0), listed in [Table 17-1](#).

**REGISTER 17-1: LCDCON: LCD CONTROL REGISTER**

R/W-0	R/W-0	R/C-0	U-0	R/W-0	R/W-0	R/W-0	R/W-0
LCDEN	SLPEN	WERR	—	CS1	CS0	LMUX1	LMUX0
bit 7							bit 0

Legend:	C = Clearable bit		
R = Readable bit	W = Writable bit	U = Unimplemented bit, read as '0'	
-n = Value at POR	'1' = Bit is set	'0' = Bit is cleared	x = Bit is unknown

- bit 7 **LCDEN:** LCD Driver Enable bit  
1 = LCD driver module is enabled  
0 = LCD driver module is disabled
- bit 6 **SLPEN:** LCD Driver Enable in Sleep mode bit  
1 = LCD driver module is disabled in Sleep mode  
0 = LCD driver module is enabled in Sleep mode
- bit 5 **WERR:** LCD Write Failed Error bit  
1 = LCDDATAx register written while LCDPS<4> = 0 (must be cleared in software)  
0 = No LCD write error
- bit 4 **Unimplemented:** Read as '0'
- bit 3-2 **CS<1:0>:** Clock Source Select bits  
1x = INTRC (31 kHz)  
01 = T13CKI (Timer1)  
00 = System clock (Fosc/4)
- bit 1-0 **LMUX<1:0>:** Commons Select bits

LMUX<1:0>	Multiplex Type	Maximum Number of Pixels	Bias Type
00	Static (COM0)	33	Static
01	1/2 (COM1:COM0)	66	1/2 or 1/3
10	1/3 (COM2:COM0)	99	1/2 or 1/3
11	1/4 (COM3:COM0)	132	1/3

# PIC18F87J72

## REGISTER 17-2: LCDPS: LCD PHASE REGISTER

R/W-0	R/W-0	R-0	R-0	R/W-0	R/W-0	R/W-0	R/W-0
WFT	BIASMD	LCDA	WA	LP3	LP2	LP1	LP0
bit 7							bit 0

### Legend:

R = Readable bit	W = Writable bit	U = Unimplemented bit, read as '0'
-n = Value at POR	'1' = Bit is set	'0' = Bit is cleared
		x = Bit is unknown

- bit 7      **WFT:** Waveform Type Select bit  
1 = Type-B waveform (phase changes on each frame boundary)  
0 = Type-A waveform (phase changes within each common type)
- bit 6      **BIASMD:** Bias Mode Select bit  
When LMUX<1:0> = 00:  
0 = Static Bias mode (do not set this bit to '1')
- When LMUX<1:0> = 01 or 10:  
1 = 1/2 Bias mode  
0 = 1/3 Bias mode
- When LMUX<1:0> = 11:  
0 = 1/3 Bias mode (do not set this bit to '1')
- bit 5      **LCDA:** LCD Active Status bit  
1 = LCD driver module is active  
0 = LCD driver module is inactive
- bit 4      **WA:** LCD Write Allow Status bit  
1 = Write into the LCDDATAx registers is allowed  
0 = Write into the LCDDATAx registers is not allowed
- bit 3-0    **LP<3:0>:** LCD Prescaler Select bits  
1111 = 1:16  
1110 = 1:15  
1101 = 1:14  
1100 = 1:13  
1011 = 1:12  
1010 = 1:11  
1001 = 1:10  
1000 = 1:9  
0111 = 1:8  
0110 = 1:7  
0101 = 1:6  
0100 = 1:5  
0011 = 1:4  
0010 = 1:3  
0001 = 1:2  
0000 = 1:1

## REGISTER 17-3: LCDSE<sub>x</sub>: LCD SEGMENT ENABLE REGISTERS

R/W-0	R/W-0	R/W-0	R/W-0	R/W-0	R/W-0	R/W-0	R/W-0
SE(n + 7)	SE(n + 6)	SE(n + 5)	SE(n + 4)	SE(n + 3)	SE(n + 2)	SE(n + 1)	SE(n)
bit 7							bit 0

**Legend:**

R = Readable bit

W = Writable bit

U = Unimplemented bit, read as '0'

-n = Value at POR

'1' = Bit is set

'0' = Bit is cleared

x = Bit is unknown

bit 7-0      **SEG(n + 7):SEG(n)**: Segment Enable bits

For LCDSE0: n = 0

For LCDSE1: n = 8

For LCDSE2: n = 16

For LCDSE3: n = 24

For LCDSE4: n = 32

1 = Segment function of the pin is enabled; digital I/O disabled

0 = I/O function of the pin is enabled

**TABLE 17-1: LCDSE REGISTERS AND ASSOCIATED SEGMENTS**

Register	Segments
LCDSE0	7:0
LCDSE1	15:8
LCDSE2	23:16
LCDSE3	31:24
LCDSE4 <sup>(1)</sup>	32

**Note 1:** Only LCDSE4<0> (SEG32) is implemented.

# PIC18F87J72

## 17.1.2 LCD DATA REGISTERS

Once the module is initialized for the LCD panel, the individual bits of the LCDDATA registers are cleared or set to represent a clear or dark pixel, respectively. Specific sets of LCDDATA registers are used with specific segments and common signals. Each bit represents a unique combination of a specific segment connected to a specific common.

Individual LCDDATA bits are named by the convention “SxxCy”, with “xx” as the segment number and “y” as the common number. The relationship is summarized in [Table 17-2](#). The prototype LCDDATA register is shown in [Register 17-4](#).

**Note:** LCDDATA5, LCDDATA11 and LCDDATA17 are not implemented.

**REGISTER 17-4: LCDDATAx: LCD DATA REGISTERS<sup>(1)</sup>**

R/W-0	R/W-0	R/W-0	R/W-0	R/W-0	R/W-0	R/W-0	R/W-0
S(n + 7)Cy	S(n + 6)Cy	S(n + 5)Cy	S(n + 4)Cy	S(n + 3)Cy	S(n + 2)Cy	S(n + 1)Cy	S(n)Cy
bit 7							bit 0

Legend:			
R = Readable bit	W = Writable bit	U = Unimplemented bit, read as ‘0’	
-n = Value at POR	‘1’ = Bit is set	‘0’ = Bit is cleared	x = Bit is unknown

bit 7-0     **S(n + 7)Cy:S(n)Cy:** Pixel On bits  
 For LCDDATA0 through LCDDATA5:  $n = (8x), y = 0^{(1)}$   
 For LCDDATA6 through LCDDATA10:  $n = (8(x - 6)), y = 1$   
 For LCDDATA12 through LCDDATA16:  $n = (8(x - 12)), y = 2^{(1)}$   
 For LCDDATA18 through LCDDATA22:  $n = (8(x - 18)), y = 3^{(1)}$   
 1 = Pixel on (dark)  
 0 = Pixel off (clear)

**Note 1:** LCDDATA5, LCDDATA11 and LCDDATA17 are not implemented.

**TABLE 17-2: LCDDATA REGISTERS AND BITS FOR SEGMENT AND COM COMBINATIONS**

Segments	COM Lines			
	0	1	2	3
0 through 7	LCDDATA0	LCDDATA6	LCDDATA12	LCDDATA18
	S00C0:S07C0	S00C1:S07C1	S00C2:S07C2	S00C3:S07C3
8 through 15	LCDDATA1	LCDDATA7	LCDDATA13	LCDDATA19
	S08C0:S15C0	S08C1:S15C1	S08C2:S15C2	S08C3:S15C3
16 through 23	LCDDATA2	LCDDATA8	LCDDATA14	LCDDATA20
	S16C0:S23C0	S16C1:S23C1	S16C2:S23C2	S16C3:S23C3
24 through 31	LCDDATA3	LCDDATA9	LCDDATA15	LCDDATA21
	S24C0:S31C0	S24C1:S31C1	S24C2:S31C2	S24C3:S31C3
32	LCDDATA4 <sup>(1)</sup>	LCDDATA10 <sup>(1)</sup>	LCDDATA16 <sup>(1)</sup>	LCDDATA22 <sup>(1)</sup>
	S32C0	S32C1	S32C2	S32C3

**Note 1:** Only bit<0> of these registers is implemented.

## 17.2 LCD Clock Source

The LCD driver module generates its internal clock from three possible sources:

- System clock ( $F_{osc}/4$ )
- Timer1 oscillator
- INTRC source

The LCD clock generator uses a configurable divide-by-32/divide-by-8192 postscaler to produce a baseline frequency of about 1 kHz nominal, regardless of the source selected. The clock source selection and the postscaler configuration are determined by the Clock Source Select bits,  $CS<1:0>$  ( $LCDCON<3:2>$ ).

An additional programmable prescaler is used to derive the LCD frame frequency from the 1 kHz baseline. The prescaler is configured using the  $LP<3:0>$  bits ( $LCDPS<3:0>$ ) for any one of 16 options, ranging from 1:1 to 1:16.

Proper timing for waveform generation is set by the  $LMUX<1:0>$  bits ( $LCDCON<1:0>$ ). These bits determine which Commons Multiplexing mode is to be used, and divide down the LCD clock source as required. They also determine the configuration of the ring counter that is used to switch the LCD commons on or off.

### 17.2.1 LCD VOLTAGE REGULATOR CLOCK SOURCE

In addition to the clock source for LCD timing, a separate 31 kHz nominal clock is required for the LCD charge pump. This is provided from a distinct branch of the LCD clock source.

The charge pump clock can use either the Timer1 oscillator or the INTRC source, as well as the 8 MHz INTOSC source (after being divided by 256 by a prescaler). The charge pump clock source is configured using the  $CKSEL<1:0>$  bits ( $LCDREG<1:0>$ ).

### 17.2.2 CLOCK SOURCE CONSIDERATIONS

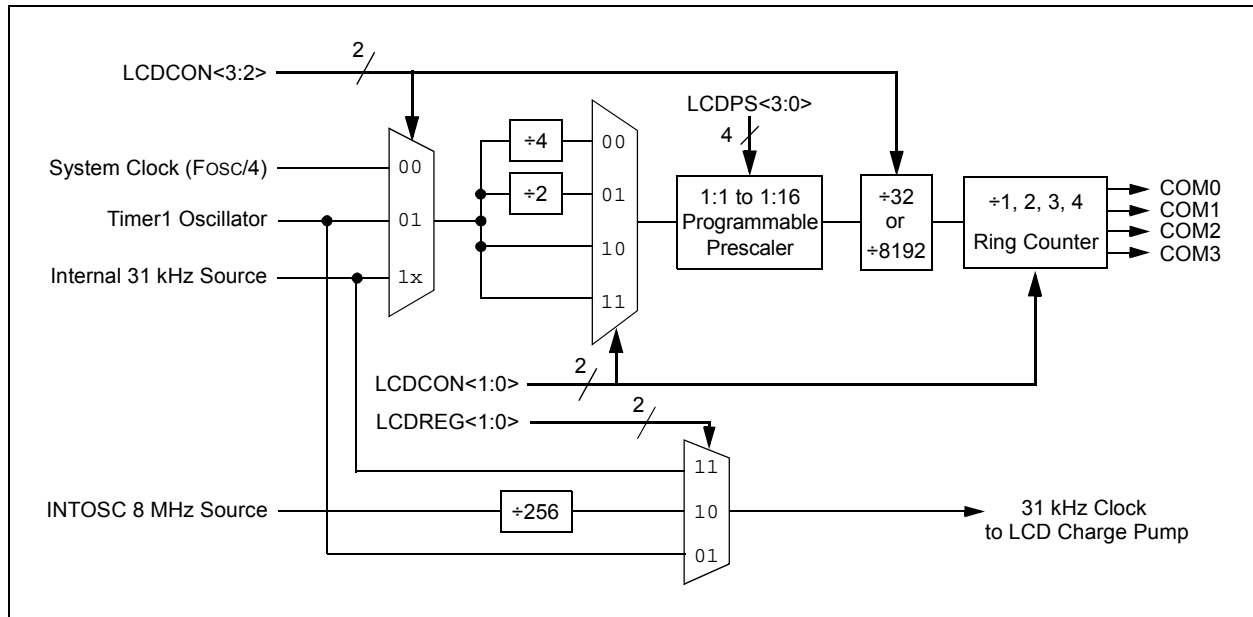
When using the system clock as the LCD clock source, it is assumed that the system clock frequency is a nominal 32 MHz (for a  $F_{osc}/4$  frequency of 8 MHz). Because the prescaler option for the  $F_{osc}/4$  clock selection is fixed at divide-by-8192, system clock speeds that differ from 32 MHz will produce frame frequencies and refresh rates different than discussed in this chapter. The user will need to keep this in mind when designing the display application.

The Timer1 and INTRC sources can be used as LCD clock sources when the device is in Sleep mode. To use the Timer1 oscillator, it is necessary to set the  $T1OSCEN$  bit ( $T1CON<3>$ ). Selecting either Timer1 or INTRC as the LCD clock source will not automatically activate these sources.

Similarly, selecting the INTOSC as the charge pump clock source will not turn the oscillator on. To use INTOSC, it must be selected as the system clock source by using the  $FOSC2$  Configuration bit.

If Timer1 is used as a clock source for the device, either as an LCD clock source or for any other purpose, LCD Segment 32 becomes unavailable.

**FIGURE 17-2: LCD CLOCK GENERATION**



# PIC18F87J72

## 17.3 LCD Bias Generation

The LCD driver module is capable of generating the required bias voltages for LCD operation with a minimum of external components. This includes the ability to generate the different voltage levels required by the different bias types required by the LCD. The driver module can also provide bias voltages both above and below microcontroller VDD through the use of an on-chip LCD voltage regulator.

### 17.3.1 LCD BIAS TYPES

PIC18F87J72 family devices support three bias types based on the waveforms generated to control segments and commons:

- Static (two discrete levels)
- 1/2 Bias (three discrete levels)
- 1/3 Bias (four discrete levels)

The use of different waveforms in driving the LCD is discussed in more detail in [Section 17.8 “LCD Waveform Generation”](#).

### 17.3.2 LCD VOLTAGE REGULATOR

The purpose of the LCD regulator is to provide proper bias voltage and good contrast for the LCD, regardless of VDD levels. This module contains a charge pump and internal voltage reference. The regulator can be configured by using external components to boost bias voltage above VDD. It can also operate a display at a constant voltage below VDD. The regulator can also be selectively disabled to allow bias voltages to be generated by an external resistor network.

The LCD regulator is controlled through the LCDREG register ([Register 17-5](#)). It is enabled or disabled using the CKSEL<1:0> bits, while the charge pump can be selectively enabled using the CPEN bit. When the regulator is enabled, the MODE13 bit is used to select the bias type. The peak LCD bias voltage, measured as a difference between the potentials of LCDBIAS3 and LCDBIAS0, is configured with the BIAS bits.

**REGISTER 17-5: LCDREG: VOLTAGE REGULATOR CONTROL REGISTER**

U-0	RW-0	RW-1	RW-1	RW-1	RW-1	RW-0	RW-0
—	CPEN	BIAS2	BIAS1	BIAS0	MODE13	CKSEL1	CKSEL0
bit 7							bit 0

Legend:

R = Readable bit

W = Writable bit

U = Unimplemented bit, read as '0'

-n = Value at POR

'1' = Bit is set

'0' = Bit is cleared

x = Bit is unknown

bit 7 **Unimplemented:** Read as '0'

bit 6 **CPEN:** LCD Charge Pump Enable bit

1 = Charge pump enabled; highest LCD bias voltage is 3.6V

0 = Charge pump disabled; highest LCD bias voltage is AVDD

bit 5-3 **BIAS<2:0>:** Regulator Voltage Output Control bits

111 = 3.60V peak (offset on LCDBIAS0 of 0V)

110 = 3.47V peak (offset on LCDBIAS0 of 0.13V)

101 = 3.34V peak (offset on LCDBIAS0 of 0.26V)

100 = 3.21V peak (offset on LCDBIAS0 of 0.39V)

011 = 3.08V peak (offset on LCDBIAS0 of 0.52V)

010 = 2.95V peak (offset on LCDBIAS0 of 0.65V)

001 = 2.82V peak (offset on LCDBIAS0 of 0.78V)

000 = 2.69V peak (offset on LCDBIAS0 of 0.91V)

bit 2 **MODE13:** 1/3 LCD Bias Enable bit

1 = Regulator output supports 1/3 LCD Bias mode

0 = Regulator output supports Static LCD Bias mode

bit 1-0 **CKSEL<1:0>:** Regulator Clock Source Select bits

11 = INTRC

10 = INTOSC 8 MHz source

01 = Timer1 oscillator

00 = LCD regulator disabled

## 17.3.3 BIAS CONFIGURATIONS

PIC18F87J72 family devices have four distinct circuit configurations for LCD bias generation:

- M0: Regulator with Boost
- M1: Regulator without Boost
- M2: Resistor Ladder with Software Contrast
- M3: Resistor Ladder with Hardware Contrast

### 17.3.3.1 M0 (Regulator with Boost)

In M0 operation, the LCD charge pump feature is enabled. This allows the regulator to generate voltages up to +3.6V to the LCD (as measured at LCDBIAS3).

M0 uses a flyback capacitor connected between VLCAP1 and VLCAP2, as well as filter capacitors on LCDBIAS0 through LCDBIAS3, to obtain the required voltage boost (Figure 17-3). The output voltage ( $V_{BIAS}$ ) is the difference of potential between LCDBIAS3 and LCDBIAS0. It is set by the  $BIAS<2:0>$  bits which adjust the offset between LCDBIAS0 and  $V_{SS}$ . The flyback capacitor ( $C_{FLY}$ ) acts as a charge storage element for large LCD loads. This mode is useful in those cases where the voltage requirements of the LCD are higher than the microcontroller's  $V_{DD}$ . It also permits software control of the display's contrast by adjustment of bias voltage by changing the value of the BIAS bits.

M0 supports Static and 1/3 Bias types. Generation of the voltage levels for 1/3 Bias is handled automatically, but must be configured in software.

M0 is enabled by selecting a valid regulator clock source ( $CKSEL<1:0>$  set to any value except '00') and setting the CPEN bit. If Static Bias type is required, the MODE13 bit must be cleared.

### 17.3.3.2 M1 (Regulator without Boost)

M1 operation is similar to M0, but does not use the LCD charge pump. It can provide  $V_{BIAS}$  up to the voltage level supplied directly to LCDBIAS3. It can be used in cases where  $V_{DD}$  for the application is expected to never drop below a level that can provide adequate contrast for the LCD. The connection of external components is very similar to M0, except that LCDBIAS3 must be tied directly to  $V_{DD}$  (Figure 17-3).

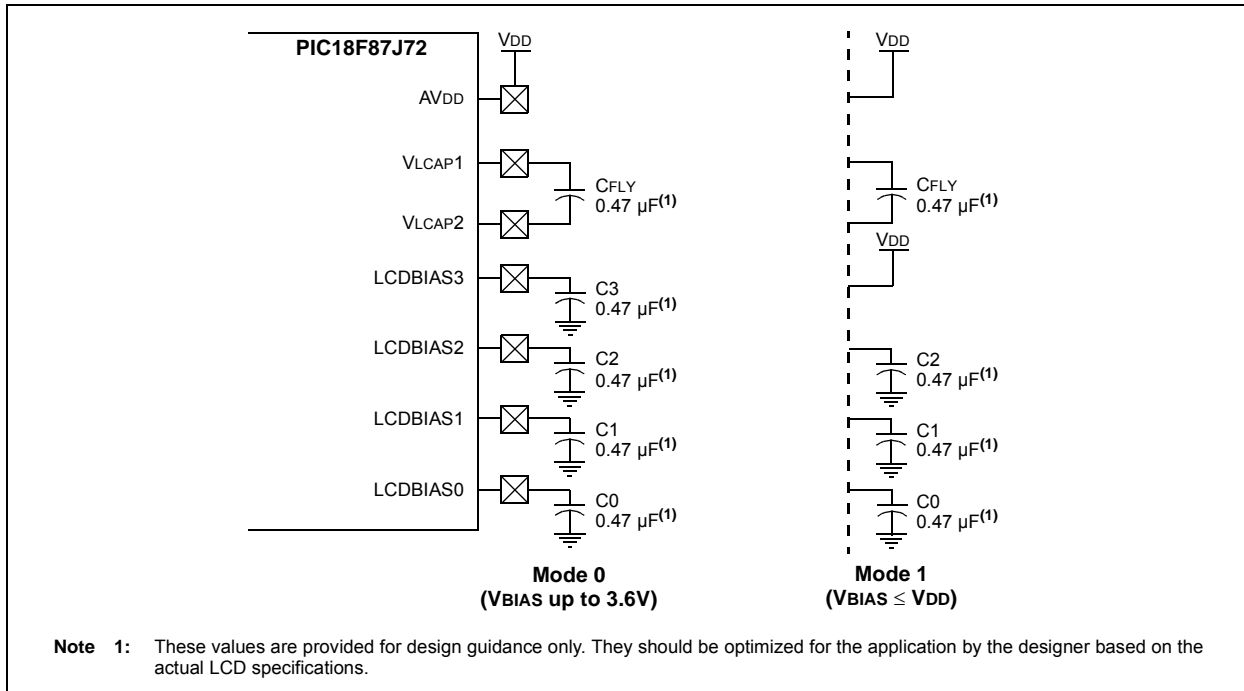
The  $BIAS<2:0>$  bits can still be used to adjust contrast in software by changing  $V_{BIAS}$ . As with M0, changing these bits changes the offset between LCDBIAS0 and  $V_{SS}$ . In M1, this is reflected in the change between the LCDBIAS0 and the voltage tied to LCDBIAS3. Thus, if  $V_{DD}$  should change,  $V_{BIAS}$  will also change; where in M0, the level of  $V_{BIAS}$  is constant.

Like M0, M1 supports Static and 1/3 Bias types. Generation of the voltage levels for 1/3 Bias is handled automatically but must be configured in software.

M1 is enabled by selecting a valid regulator clock source ( $CKSEL<1:0>$  set to any value except '00') and clearing the CPEN bit. If 1/3 Bias type is required, the MODE13 bit should also be set.

**Note:** When the device enters Sleep mode while operating in Bias modes, M0 or M1, be sure that the bias capacitors are fully discharged in order to get the lowest Sleep current.

**FIGURE 17-3: LCD REGULATOR CONNECTIONS FOR M0 AND M1 CONFIGURATIONS**



# PIC18F87J72

## 17.3.3.3 M2 (Resistor Ladder with Software Contrast)

M2 operation also uses the LCD regulator but disables the charge pump. The regulator's internal voltage reference remains active as a way to regulate contrast. It is used in cases where the current requirements of the LCD exceed the capacity of the regulator's charge pump.

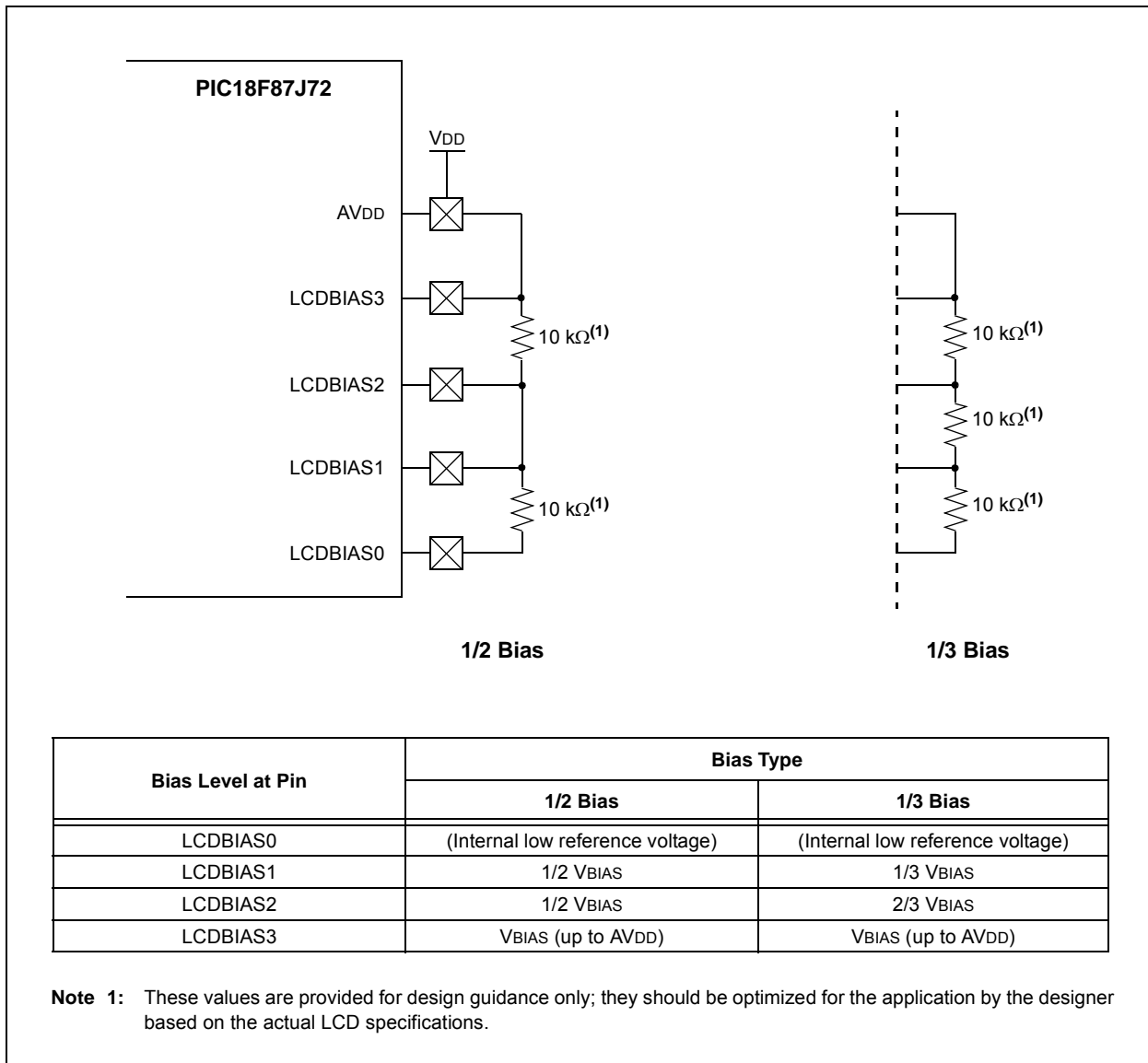
In this configuration, the LCD bias voltage levels are created by an external resistor voltage divider connected across LCDBIAS0 through LCDBIAS3, with the top of the divider tied to VDD (Figure 17-4). The potential at the bottom of the ladder is determined by the LCD regulator's voltage reference, tied internally to LCDBIAS0. The bias type is determined by the voltages on the LCDBIAS pins, which are controlled by the

configuration of the resistor ladder. Most applications using M2 will use a 1/3 or 1/2 Bias type. While Static Bias can also be used, it offers extremely limited contrast range and additional current consumption over other bias generation modes.

Like M1, the LCDBIAS bits can be used to control contrast, limited by the level of VDD supplied to the device. Also, since there is no capacitor required across VLCAP1 and VLCAP2, these pins are available as digital I/O ports, RG2 and RG3.

M2 is selected by clearing the CKSEL<1:0> bits and setting the CPEN bit.

**FIGURE 17-4: RESISTOR LADDER CONNECTIONS FOR M2 CONFIGURATION**





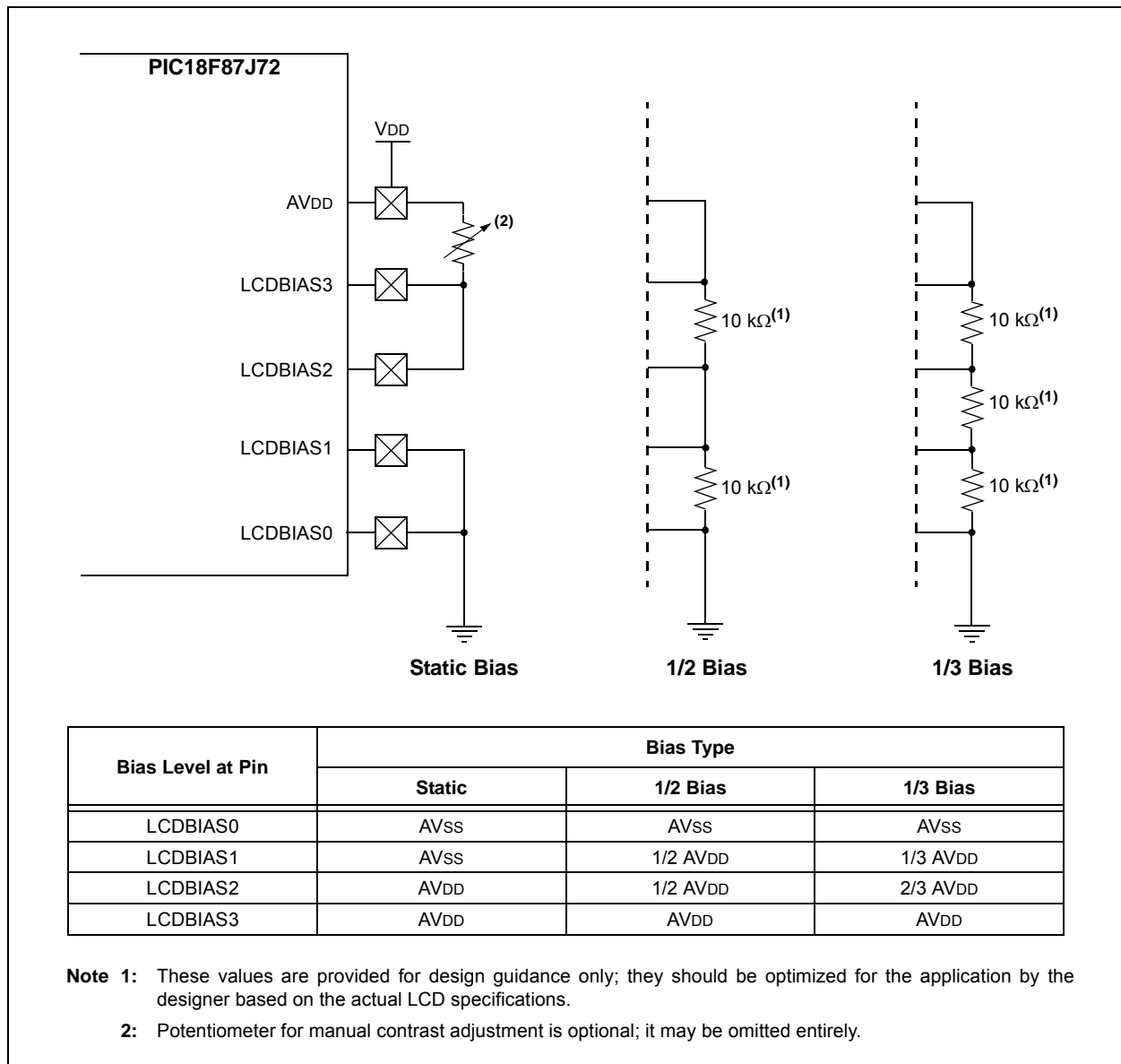
## 17.3.3.4 M3 (Hardware Contrast)

In M3, the LCD regulator is completely disabled. Like M2, LCD bias levels are tied to AVDD, and are generated using an external divider. The difference is that the internal voltage reference is also disabled and the bottom of the ladder is tied to ground (VSS); see Figure 17-5. The value of the resistors, and the difference between VSS and VDD, determine the contrast range; no software adjustment is possible. This configuration is also used where the LCD's current requirements exceed the capacity of the charge pump and software contrast control is not needed.

Depending on the bias type required, resistors are connected between some or all of the pins. A potentiometer can also be connected between LCDBIAS3 and VDD to allow for hardware controlled contrast adjustment.

M3 is selected by clearing the CKSEL<1:0> and CPEN bits.

**FIGURE 17-5: RESISTOR LADDER CONNECTIONS FOR M3 CONFIGURATION**



# PIC18F87J72

## 17.3.4 DESIGN CONSIDERATIONS FOR THE LCD CHARGE PUMP

When designing applications that use the LCD regulator with the charge pump enabled, users must always consider both the dynamic current and RMS (static) current requirements of the display, and what the charge pump can deliver. Both dynamic and static current can be determined by [Equation 17-1](#):

### EQUATION 17-1: DYNAMIC AND STATIC CURRENT

$$I = C \times \frac{dV}{dT}$$

For dynamic current,  $C$  is the value of the capacitors attached to LCDBIAS3 and LCDBIAS2. The variable,  $dV$ , is the voltage drop allowed on C2 and C3 during a voltage switch on the LCD display, and  $dT$  is the duration of the transient current after a clock pulse occurs. For practical design purposes, these will be assumed to be 0.047  $\mu\text{F}$  for  $C$ , 0.1V for  $dV$  and 1  $\mu\text{s}$  for  $dT$ . This yields a dynamic current of 4.7 mA for 1  $\mu\text{s}$ .

RMS current is determined by the value of C<sub>FLY</sub> for  $C$ , the voltage across VLCAP1 and VLCAP2 for  $dV$  and the regulator clock period (T<sub>PER</sub>) for  $dT$ . Assuming C<sub>FLY</sub> of 0.047  $\mu\text{F}$ , a value of 1.02V across C<sub>FLY</sub> and T<sub>PER</sub> of 30  $\mu\text{s}$ , the maximum theoretical static current will be 1.8 mA. Since the charge pump must charge five capacitors, the maximum current becomes 360  $\mu\text{A}$ . For a real-world assumption of 50% efficiency, this yields a practical current of 180  $\mu\text{A}$ .

Users should compare the calculated current capacity against the requirements of the LCD. While  $dV$  and  $dT$  are relatively fixed by device design, the values of C<sub>FLY</sub> and the capacitors on the LCDBIAS pins can be changed to increase or decrease current. As always, any changes should be evaluated in the actual circuit for its impact on the application.

## 17.4 LCD Multiplex Types

The LCD driver module can be configured into four multiplex types:

- Static (only COM0 used)
- 1/2 Multiplex (COM0 and COM1 are used)
- 1/3 Multiplex (COM0, COM1 and COM2 are used)
- 1/4 Multiplex (all COM0, COM1, COM2 and COM3 are used)

The number of active commons used is configured by the LMUX<1:0> bits (LCDCON<1:0>), which determines the function of the PORTE<6:4> pins (see [Table 17-3](#) for details). If the pin is configured as a COM drive, the port I/O function is disabled and the TRIS setting of that pin is overridden.

**Note:** On a Power-on Reset, the LMUX<1:0> bits are '00'.

**TABLE 17-3: PORTE<6:4> FUNCTION**

LMUX<1:0> >	PORTE<6>	PORTE<5>	PORTE<4>
00	Digital I/O	Digital I/O	Digital I/O
01	Digital I/O	Digital I/O	COM1 Driver
10	Digital I/O	COM2 Driver	COM1 Driver
11	COM3 Driver	COM2 Driver	COM1 Driver

## 17.5 Segment Enables

The LCDSE<sub>x</sub> registers are used to select the pin function for each segment pin. Setting a bit configures the corresponding pin to function as a segment driver. LCDSE<sub>x</sub> registers do not override the TRIS bit settings, so the TRIS bits must be configured as input for that pin.

**Note:** On a Power-on Reset, these pins are configured as digital I/O.

## 17.6 Pixel Control

The LCDDATA<sub>x</sub> registers contain bits which define the state of each pixel. Each bit defines one unique pixel.

[Table 17-2](#) shows the correlation of each bit in the LCDDATA<sub>x</sub> registers to the respective common and segment signals. Any LCD pixel location not being used for display can be used as general purpose RAM.

## 17.7 LCD Frame Frequency

The rate at which the COM and SEG outputs change is called the LCD frame frequency. Frame frequency is set by the LP<3:0> bits (LCDPS<3:0>) and is also affected by the Multiplex mode being used. The relationship between the Multiplex mode, LP bits setting and frame rate is shown in [Table 17-4](#) and [Table 17-5](#).

**TABLE 17-4: FRAME FREQUENCY FORMULAS**

Multiplex Mode	Frame Frequency (Hz)
Static	$\text{Clock source}/(4 \times 1 \times (\text{LP}<3:0> + 1))$
1/2	$\text{Clock source}/(2 \times 2 \times (\text{LP}<3:0> + 1))$
1/3	$\text{Clock source}/(1 \times 3 \times (\text{LP}<3:0> + 1))$
1/4	$\text{Clock source}/(1 \times 4 \times (\text{LP}<3:0> + 1))$

**TABLE 17-5: APPROXIMATE FRAME FREQUENCY (IN Hz) FOR LP PRESCALER SETTINGS**

LP<3:0>	Multiplex Mode			
	Static	1/2	1/3	1/4
1	125	125	167	125
2	83	83	111	83
3	62	62	83	62
4	50	50	67	50
5	42	42	56	42
6	36	36	48	36
7	31	31	42	31

## 17.8 LCD Waveform Generation

LCD waveform generation is based on the principle that the net AC voltage across the dark pixel should be maximized and the net AC voltage across the clear pixel should be minimized. The net DC voltage across any pixel should be zero.

The COM signal represents the time slice for each common, while the SEG contains the pixel data. The pixel signal (COM-SEG) will have no DC component and it can take only one of the two rms values. The higher rms value will create a dark pixel and a lower rms value will create a clear pixel.

As the number of commons increases, the delta between the two rms values decreases. The delta represents the maximum contrast that the display can have.

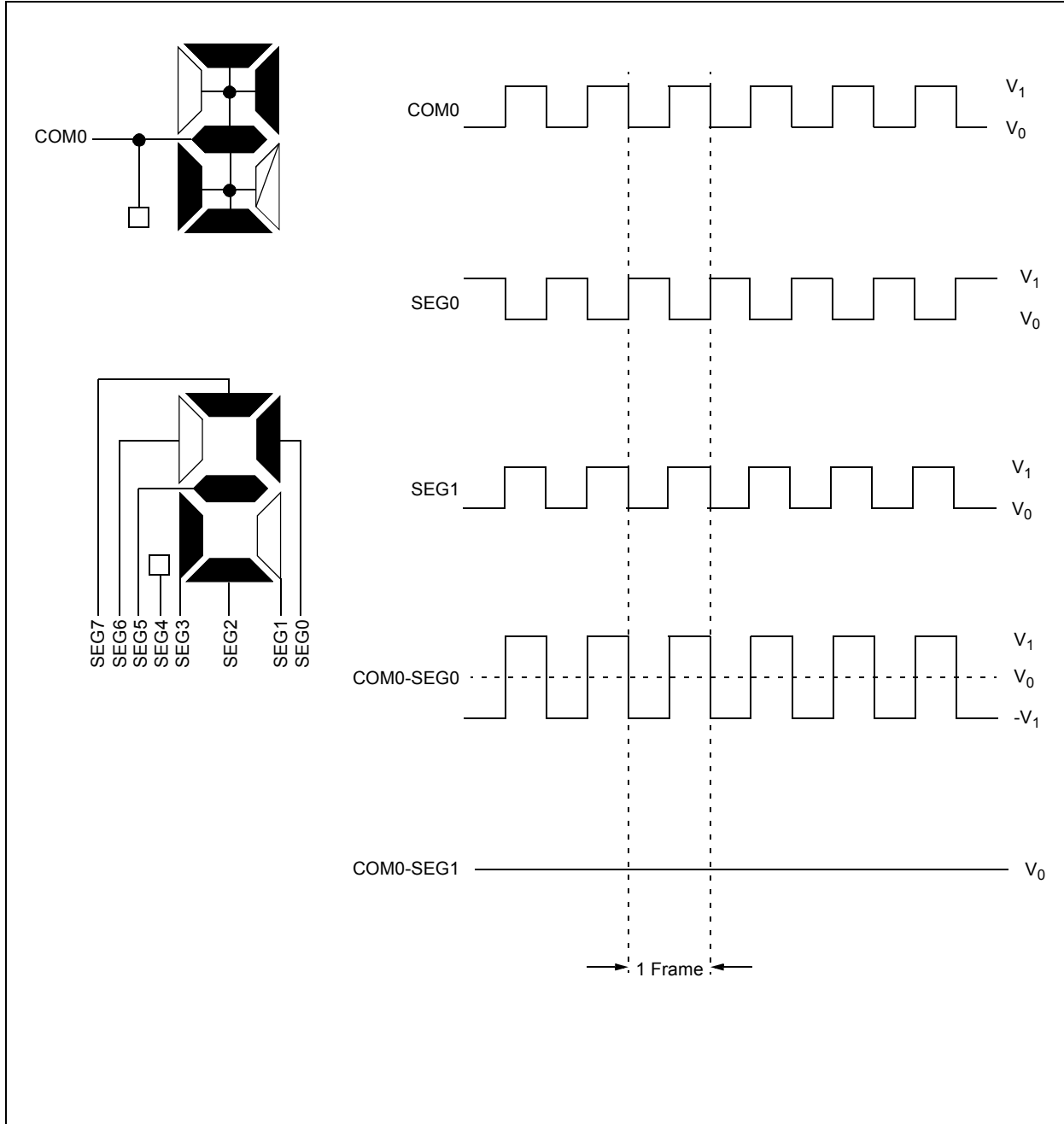
The LCDs can be driven by two types of waveform: Type-A and Type-B. In the Type-A waveform, the phase changes within each common type, whereas in the Type-B waveform, the phase changes on each frame boundary. Thus, the Type-A waveform maintains 0 VDC over a single frame, whereas the Type-B waveform takes two frames.

- Note 1:** If the power-managed Sleep mode is invoked while the LCD Sleep bit is set (LCDCON<6> is '1'), take care to execute Sleep only when the VDC on all the pixels is '0'.
- 2:** When the LCD clock source is the system clock, the LCD module will go to Sleep if the microcontroller goes into Sleep mode, regardless of the setting of the SLEN bit. Thus, always take care to see that the VDC on all pixels is '0' whenever Sleep mode is invoked.

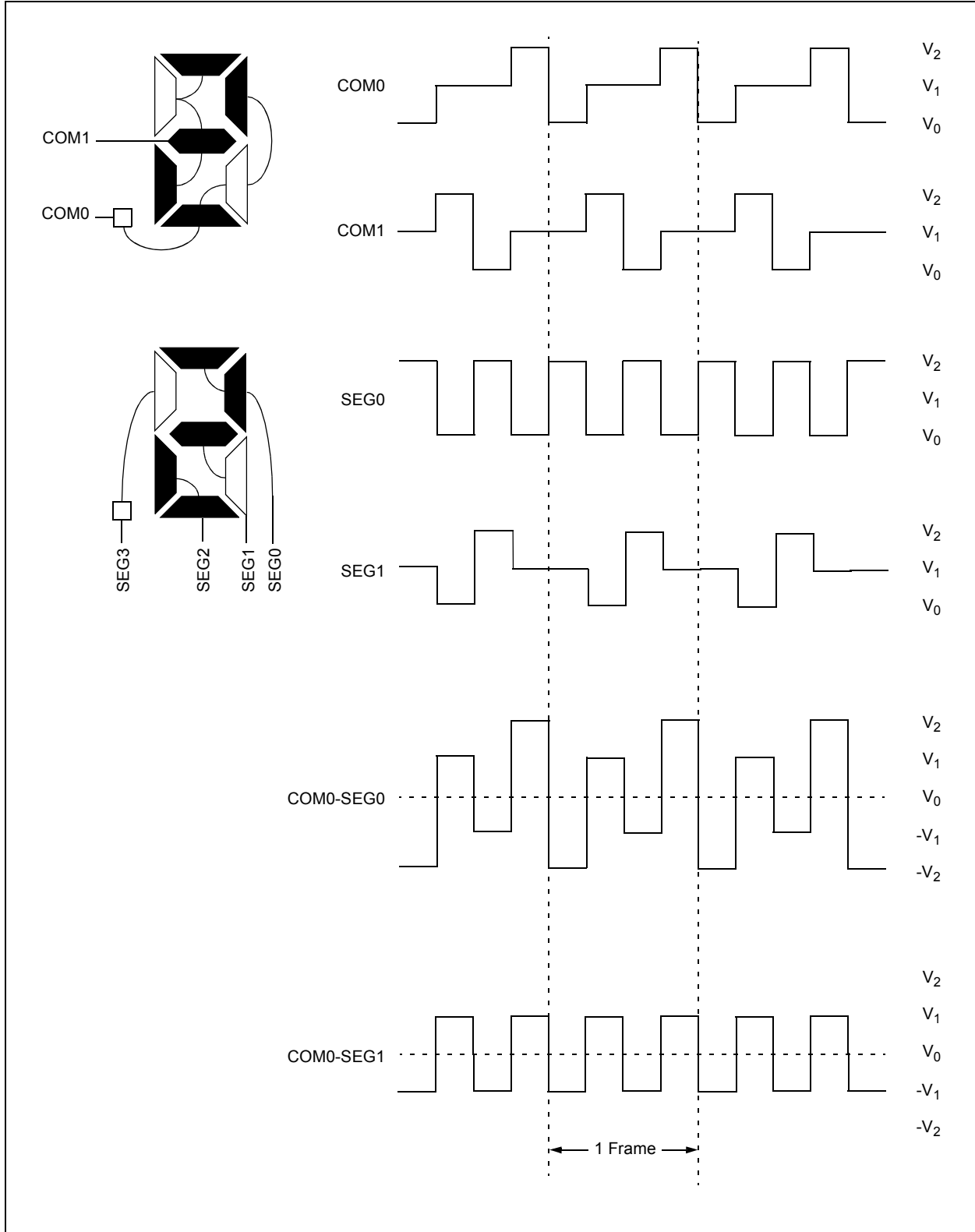
[Figure 17-6](#) through [Figure 17-16](#) provide waveforms for static, half multiplex, one-third multiplex and quarter multiplex drives for Type-A and Type-B waveforms.

# PIC18F87J72

FIGURE 17-6: TYPE-A/TYPE-B WAVEFORMS IN STATIC DRIVE

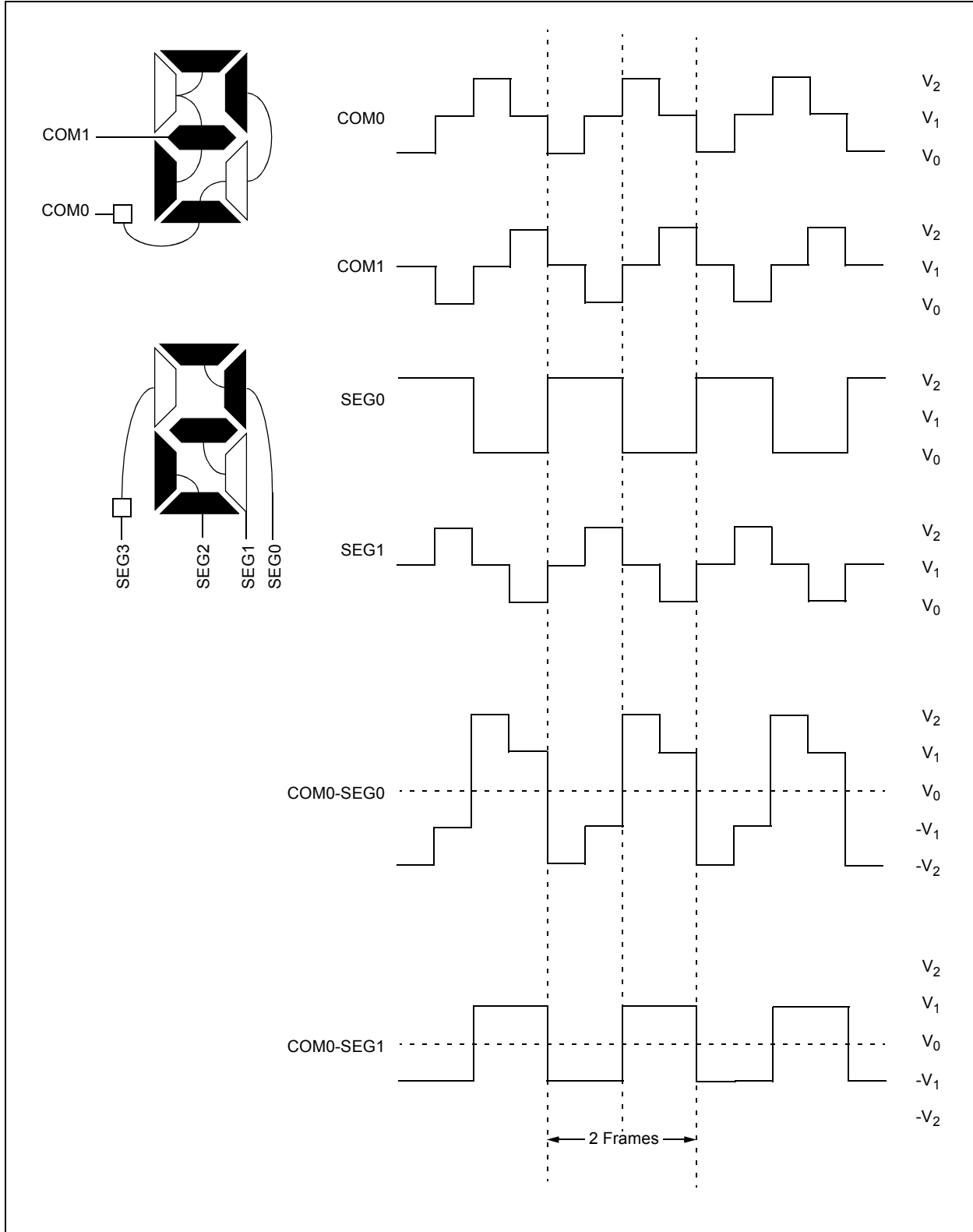


**FIGURE 17-7: TYPE-A WAVEFORMS IN 1/2 MUX, 1/2 BIAS DRIVE**

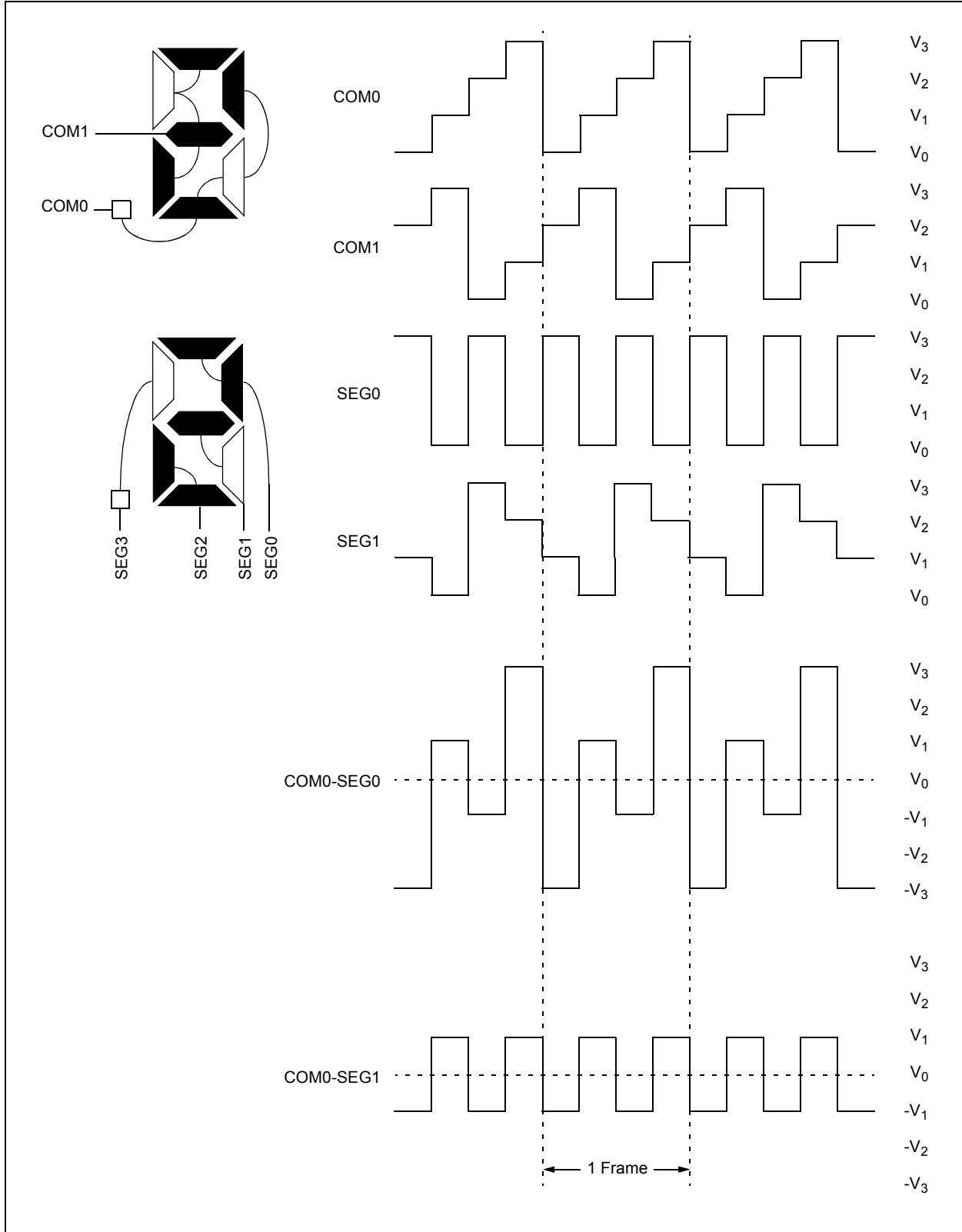


# PIC18F87J72

FIGURE 17-8: TYPE-B WAVEFORMS IN 1/2 MUX, 1/2 BIAS DRIVE

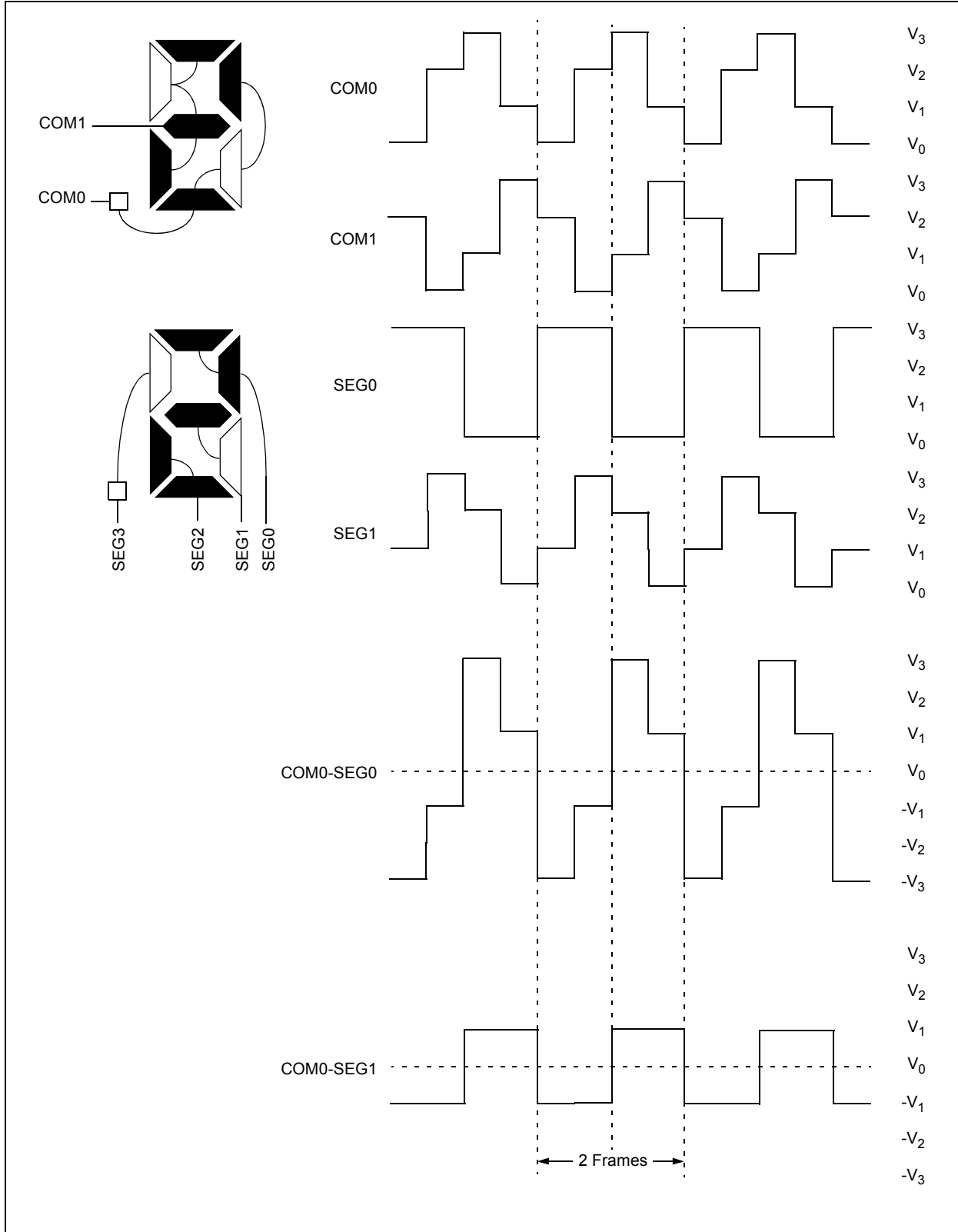


**FIGURE 17-9: TYPE-A WAVEFORMS IN 1/2 MUX, 1/3 BIAS DRIVE**



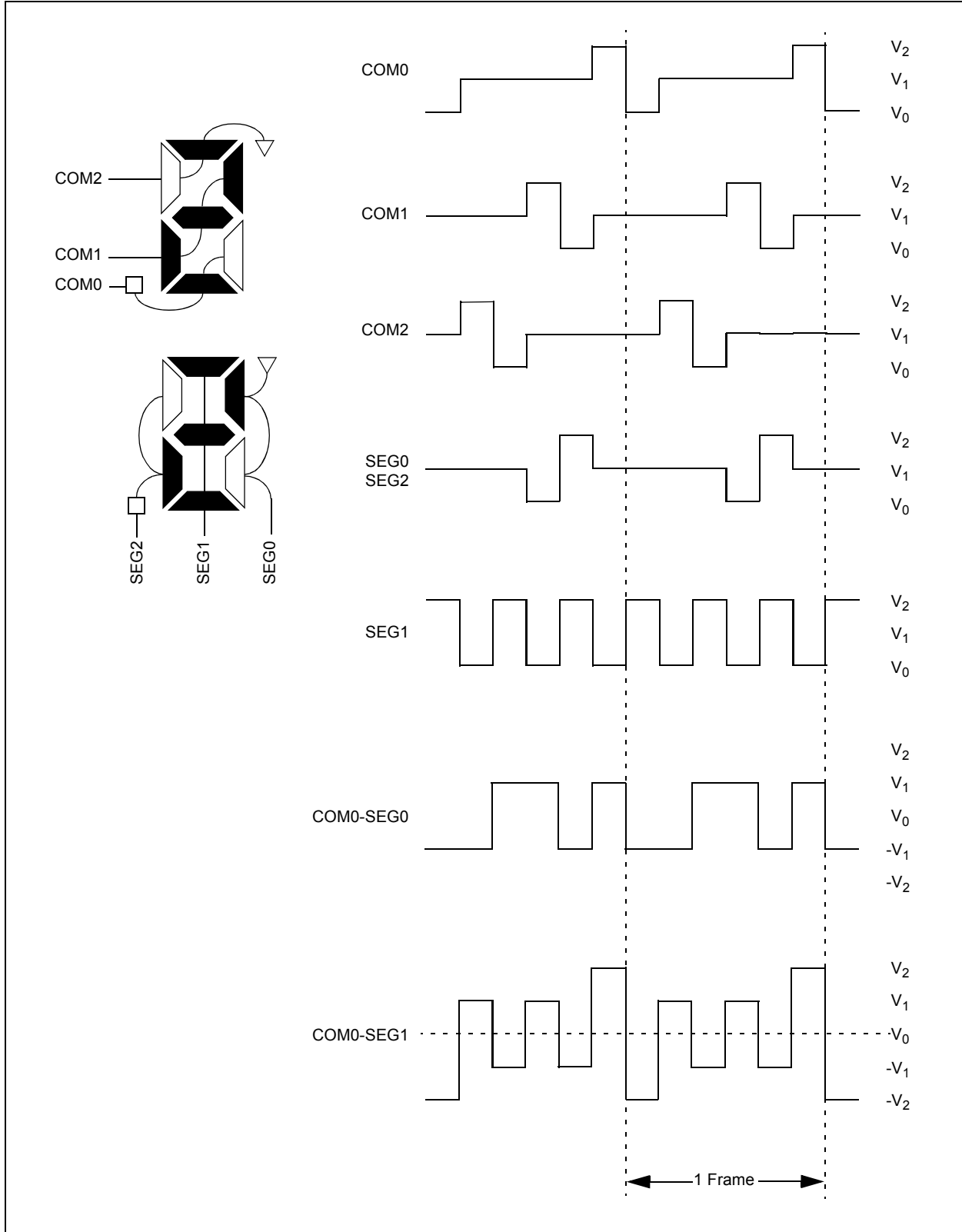
# PIC18F87J72

FIGURE 17-10: TYPE-B WAVEFORMS IN 1/2 MUX, 1/3 BIAS DRIVE



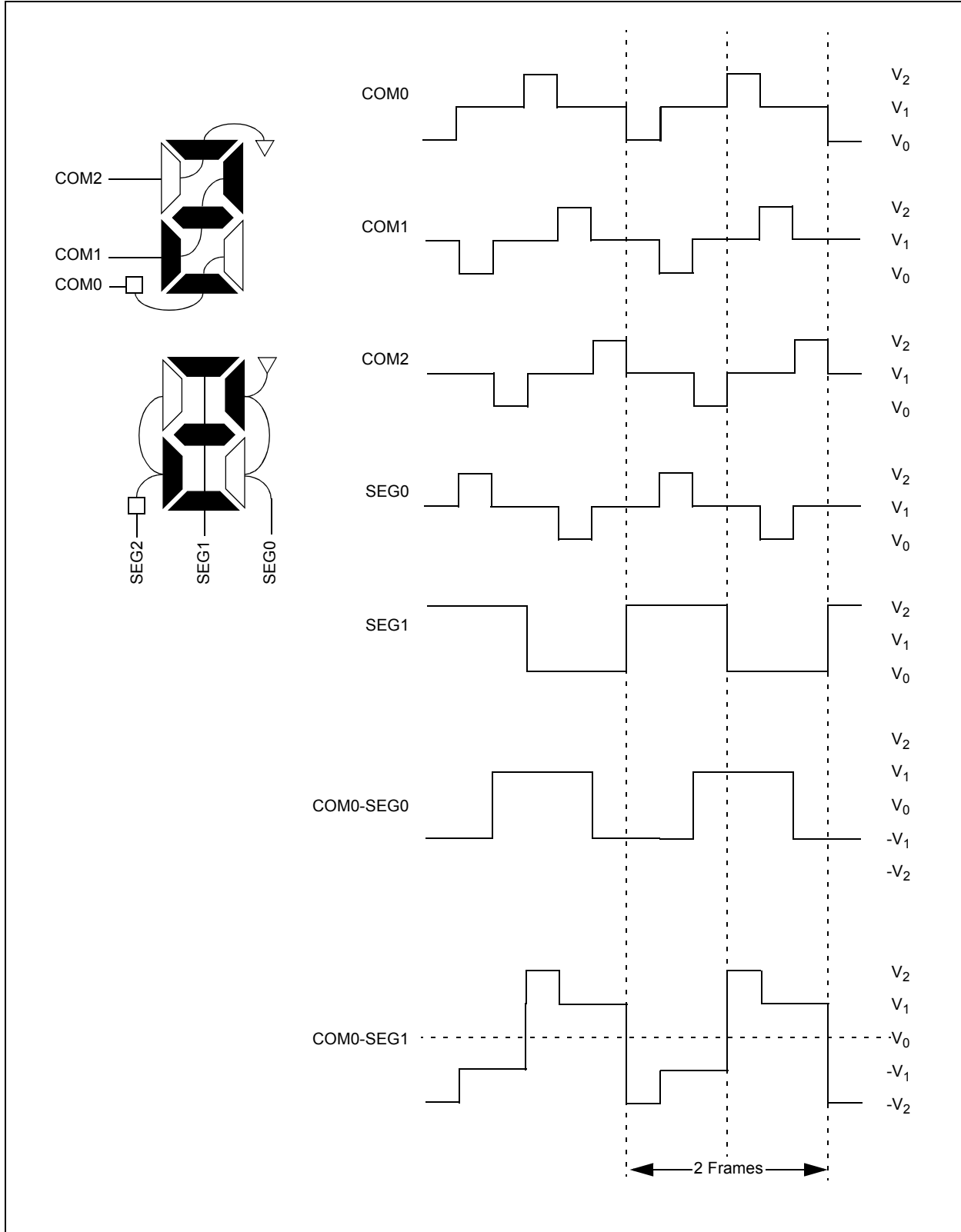


**FIGURE 17-11: TYPE-A WAVEFORMS IN 1/3 MUX, 1/2 BIAS DRIVE**

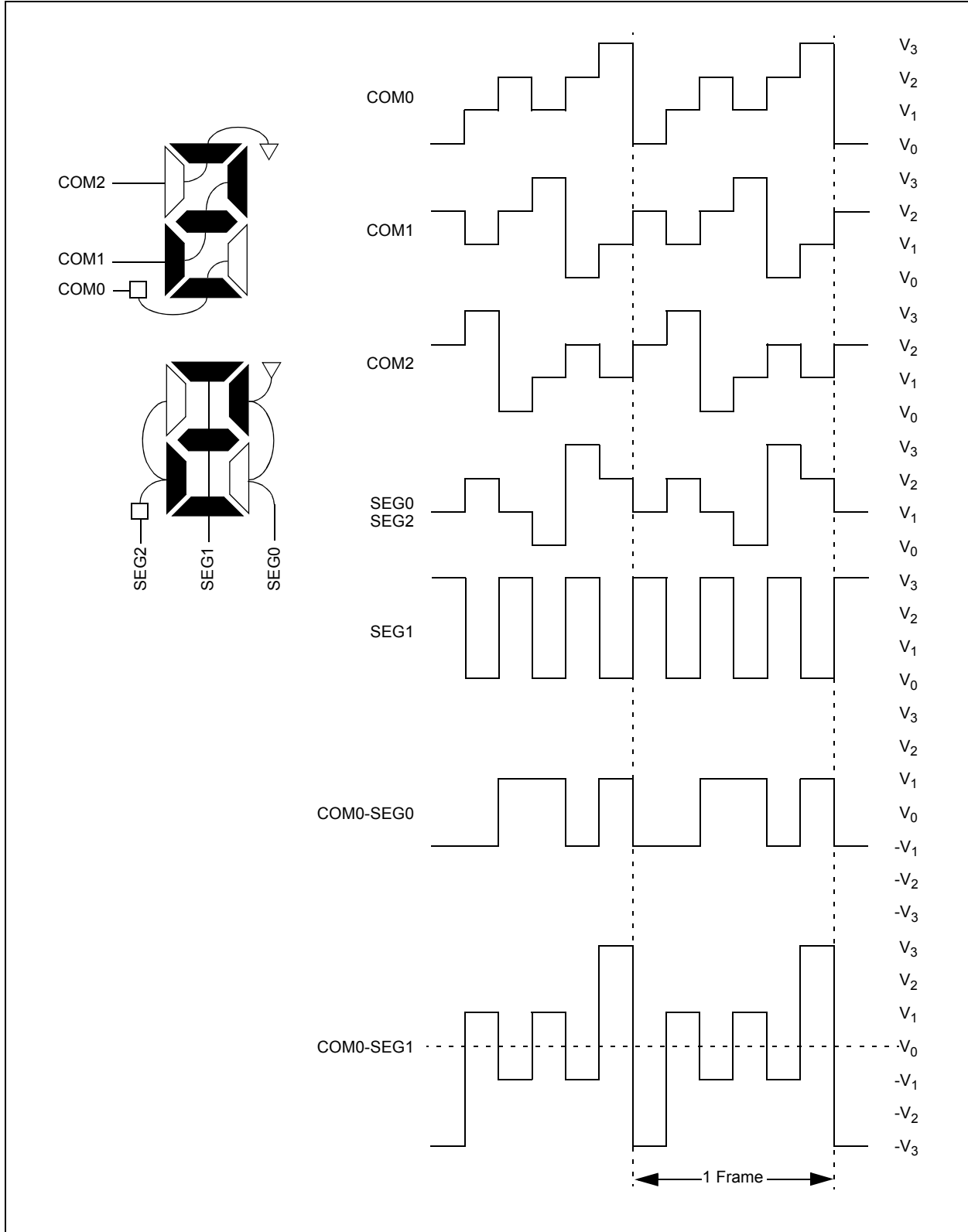


# PIC18F87J72

FIGURE 17-12: TYPE-B WAVEFORMS IN 1/3 MUX, 1/2 BIAS DRIVE

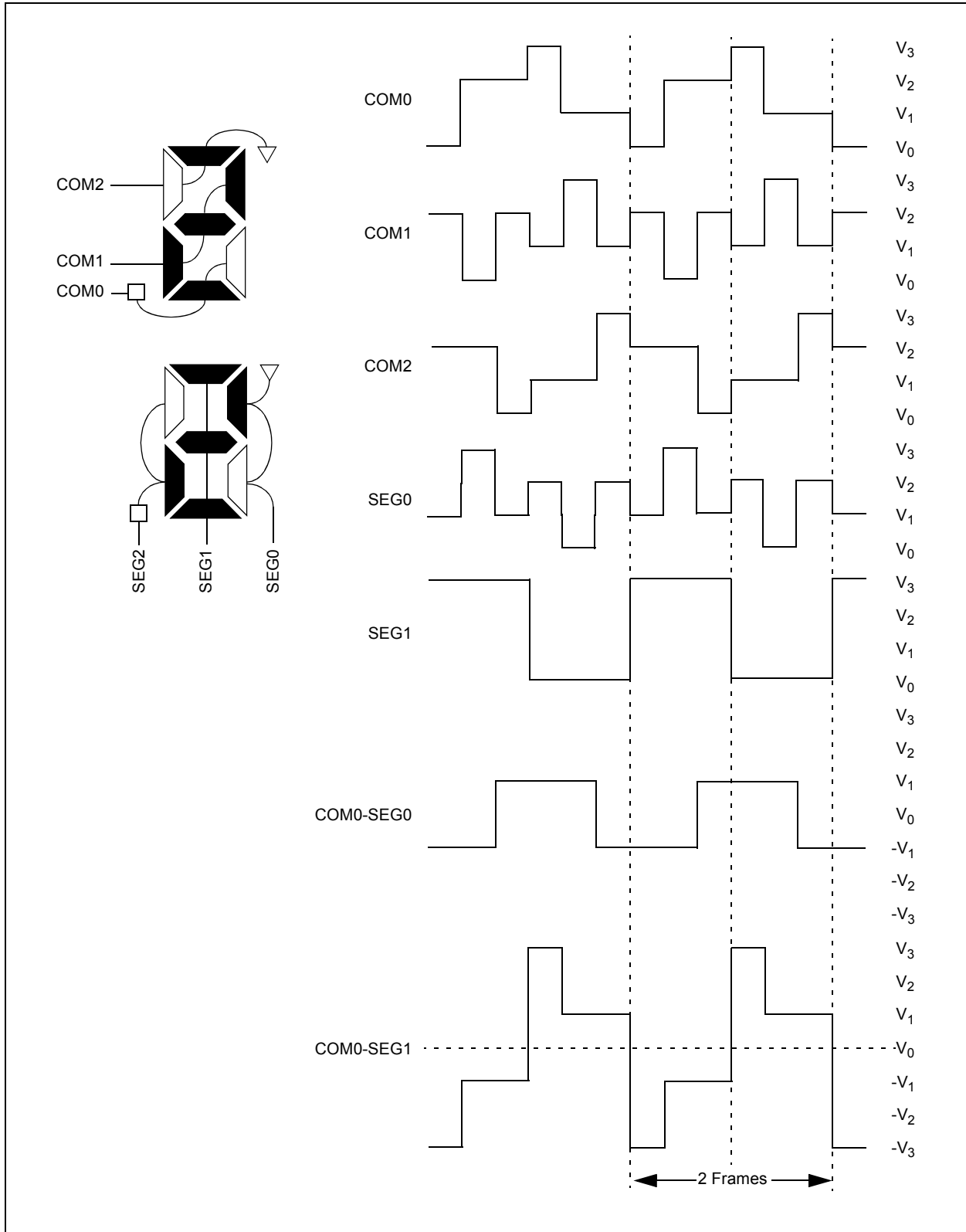


**FIGURE 17-13: TYPE-A WAVEFORMS IN 1/3 MUX, 1/3 BIAS DRIVE**

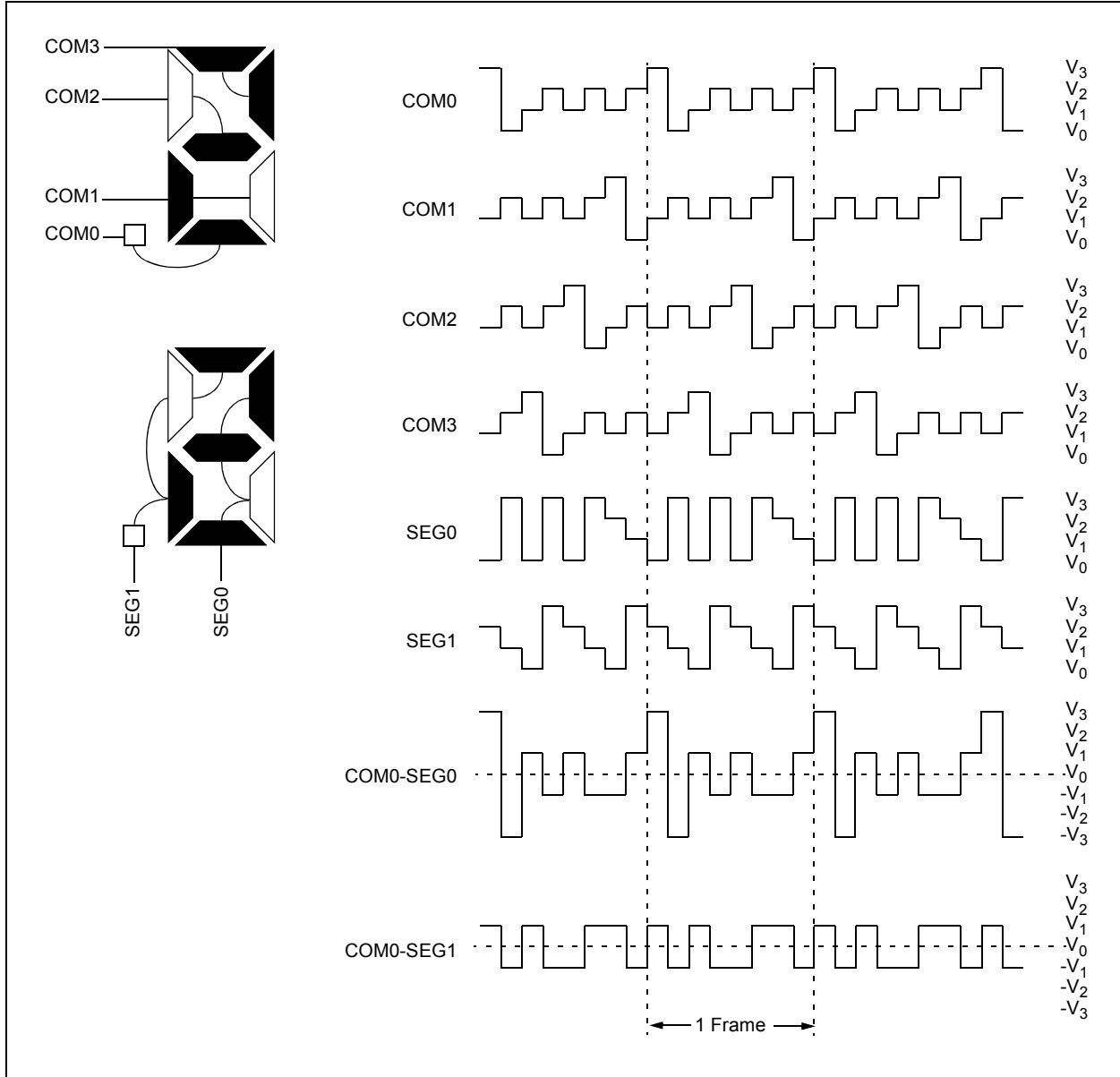


# PIC18F87J72

FIGURE 17-14: TYPE-B WAVEFORMS IN 1/3 MUX, 1/3 BIAS DRIVE

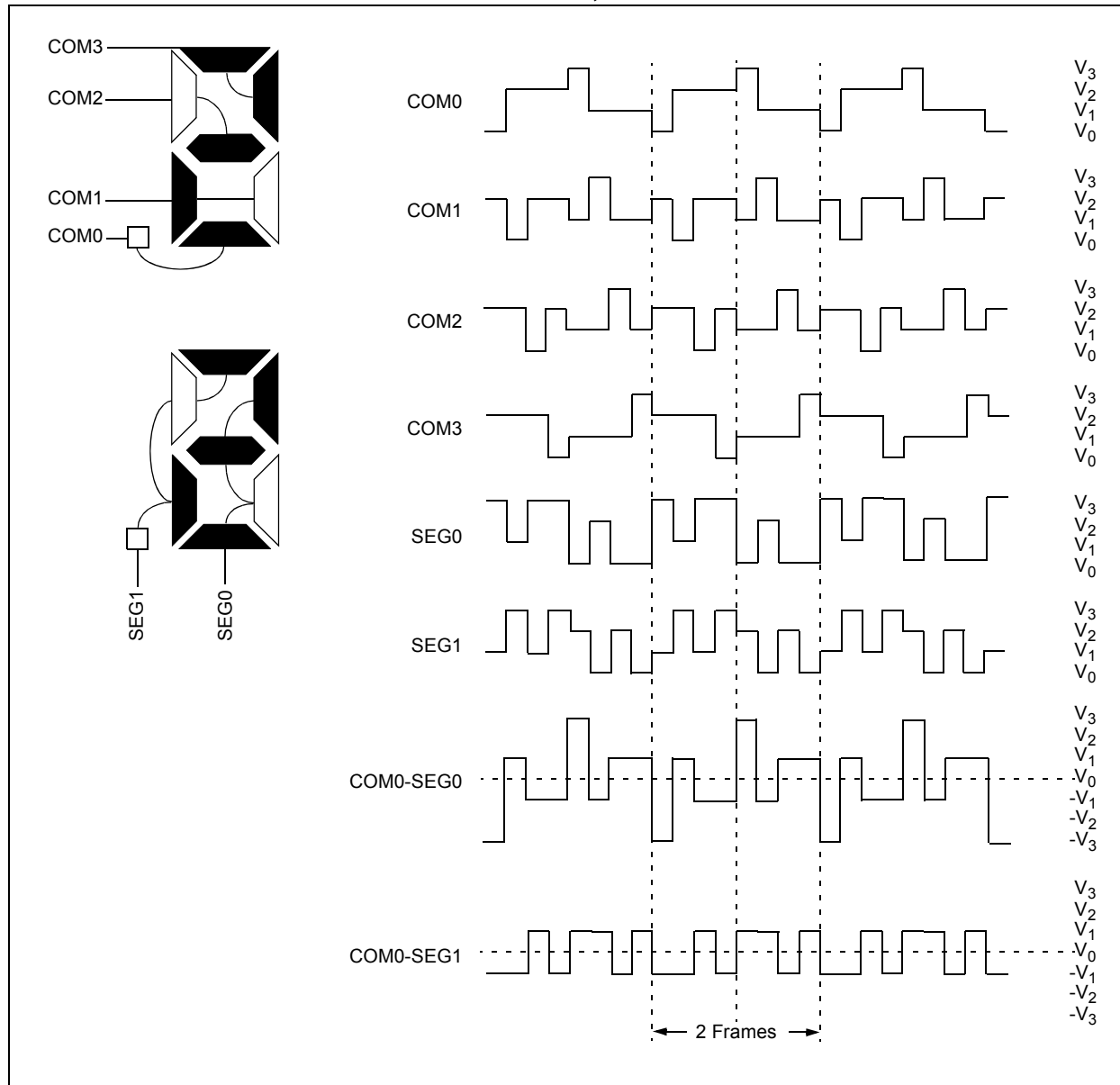


**FIGURE 17-15: TYPE-A WAVEFORMS IN 1/4 MUX, 1/3 BIAS DRIVE**



# PIC18F87J72

**FIGURE 17-16: TYPE-B WAVEFORMS IN 1/4 MUX, 1/3 BIAS DRIVE**



## 17.9 LCD Interrupts

The LCD timing generation provides an interrupt that defines the LCD frame timing. This interrupt can be used to coordinate the writing of the pixel data with the start of a new frame. Writing pixel data at the frame boundary allows a visually crisp transition of the image. This interrupt can also be used to synchronize external events to the LCD. For example, the interface to an external segment driver can be synchronized for segment data update to the LCD frame.

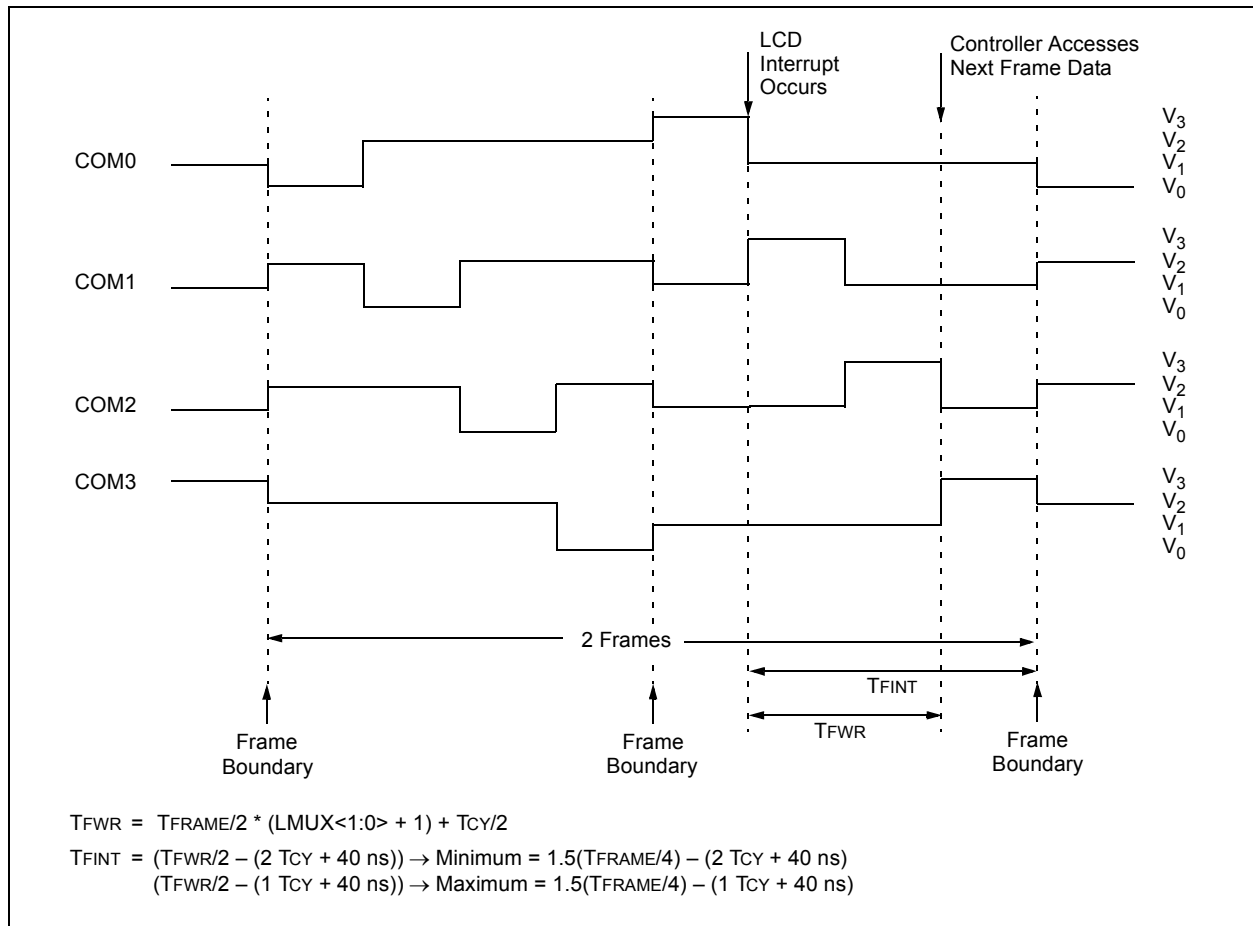
A new frame is defined to begin at the leading edge of the COM0 common signal. The interrupt will be set immediately after the LCD controller completes accessing all pixel data required for a frame. This will occur at a fixed interval before the frame boundary ( $T_{FINT}$ ), as shown in Figure 17-17. The LCD controller will begin to access data for the next frame within the interval from the interrupt to when the controller begins to access data after the interrupt ( $T_{FWR}$ ). New data must be written within  $T_{FWR}$ , as this is when the LCD controller will begin to access the data for the next frame.

When the LCD driver is running with Type-B waveforms, and the  $LMUX<1:0>$  bits are not equal to '00', there are some additional issues that must be addressed. Since the DC voltage on the pixel takes two frames to maintain zero volts, the pixel data must not change between subsequent frames. If the pixel data were allowed to change, the waveform for the odd frames would not necessarily be the complement of the waveform generated in the even frames and a DC component would be introduced into the panel. Therefore, when using Type-B waveforms, the user must synchronize the LCD pixel updates to occur within a subframe after the frame interrupt.

To correctly sequence writing while in Type-B, the interrupt will only occur on complete phase intervals. If the user attempts to write when the write is disabled, the WERR (LCDCON<5>) bit is set.

**Note:** The interrupt is not generated when the Type-A waveform is selected and when the Type-B with no multiplex (static) is selected.

**FIGURE 17-17: EXAMPLE WAVEFORMS AND INTERRUPT TIMING IN QUARTER DUTY CYCLE DRIVE**



# PIC18F87J72

## 17.10 Operation During Sleep

The LCD module can operate during Sleep. The selection is controlled by the SLPEN bit (LCDCON<6>). Setting the SLPEN bit allows the LCD module to go to Sleep. Clearing the SLPEN bit allows the module to continue to operate during Sleep.

If a SLEEP instruction is executed and SLPEN = 1, the LCD module will cease all functions and go into a very low-current consumption mode. The module will stop operation immediately and drive the minimum LCD voltage on both segment and common lines. Figure 17-18 shows this operation.

To ensure that no DC component is introduced on the panel, the SLEEP instruction should be executed immediately after a LCD frame boundary. The LCD interrupt can be used to determine the frame boundary. See [Section 17.9 “LCD Interrupts”](#) for the formulas to calculate the delay.

If a SLEEP instruction is executed and SLPEN = 0, the module will continue to display the current contents of the LCDDATA registers. To allow the module to continue operation while in Sleep, the clock source must be either the Timer1 oscillator or one of the

internal oscillators (either INTRC or INTOSC as the default system clock). While in Sleep, the LCD data cannot be changed. The LCD module current consumption will not decrease in this mode; however, the overall consumption of the device will be lower due to shutdown of the core and other peripheral functions.

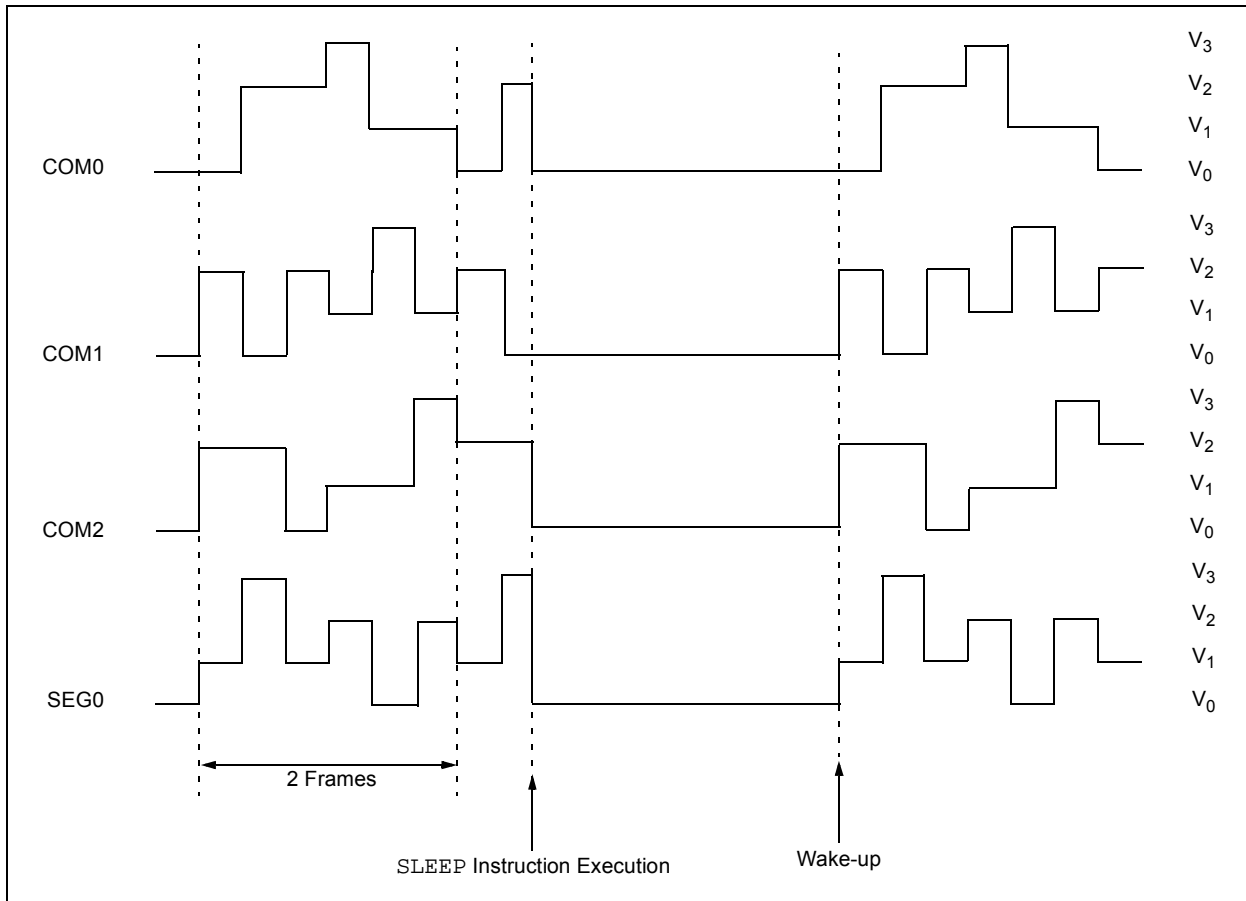
If the system clock is selected and the module is not configured for Sleep operation, the module will ignore the SLPEN bit and stop operation immediately. The minimum LCD voltage will then be driven onto the segments and commons

### 17.10.1 USING THE LCD REGULATOR DURING SLEEP

Applications that use the LCD regulator for bias generation may not achieve the same degree of power reductions in Sleep mode when compared to applications using Mode 3 (resistor ladder) biasing. This is particularly true with Mode 0 operation, where the charge pump is active.

If Modes 0, 1 or 2 are used for bias generation, software contrast control will not be available.

FIGURE 17-18: SLEEP ENTRY/EXIT WHEN SLPEN = 1 OR CS<1:0> = 00





## 17.11 Configuring the LCD Module

The following is the sequence of steps to configure the LCD module.

1. Select the frame clock prescale using bits, LP<3:0> (LCDPS<3:0>).
2. Configure the appropriate pins to function as segment drivers using the LCDSEx registers.
3. Configure the appropriate pins as inputs using the TRISx registers.
4. Configure the LCD module for the following using the LCDCON register:
  - Multiplex and Bias mode (LMUX<1:0>)
  - Timing source (CS<1:0>)
  - Sleep mode (SLPEN)
5. Write initial values to pixel data registers, LCDDATA0 through LCDDATA23.

6. Configure the LCD regulator:
  - a) If M2 or M3 bias configuration is to be used, turn off the regulator by setting CKSEL<1:0> (LCDREG<1:0>) to '00'. Set or clear the CPEN bit (LCDREG<6>) to select Mode 2 or Mode 3, as appropriate.
  - b) If M0 or M1 bias generation is to be used:
    - Set the VBIAS level using the BIAS<2:0> bits (LCDREG<5:3>).
    - Set or clear the CPEN bit to enable or disable the charge pump.
    - Set or clear the MODE13 bit (LCDREG<2>) to select the Bias mode.
    - Select a regulator clock source using the CKSEL<1:0> bits.
7. Clear LCD Interrupt Flag, LCDIF (PIR3<6>), and if desired, enable the interrupt by setting the LCDIE bit (PIE3<6>).
8. Enable the LCD module by setting the LCDEN bit (LCDCON<7>).

# PIC18F87J72

**TABLE 17-6: REGISTERS ASSOCIATED WITH LCD OPERATION**

Name	Bit 7	Bit 6	Bit 5	Bit 4	Bit 3	Bit 2	Bit 1	Bit 0	Reset Values on Page
INTCON	GIE/GIEH	PEIE/GIEL	TMR0IE	INT0IE	RBIE	TMR0IF	INT0IF	RBIF	45
PIR3	—	LCDIF	RC2IF	TX2IF	CTMUIF	CCP2IF	CCP1IF	RTCCIF	48
PIE3	—	LCDIE	RC2IE	TX2IE	CTMUIE	CCP2IE	CCP1IE	RTCCIE	48
IPR3	—	LCDIP	RC2IP	TX2IP	CTMUIP	CCP2IP	CCP1IP	RTCCIP	48
RCON	IPEN	—	CM	RI	TO	PD	POR	BOR	46
LCDDATA22	—	—	—	—	—	—	—	S32C3	49
LCDDATA21	S31C3	S30C3	S29C3	S28C3	S27C3	S26C3	S25C3	S24C3	49
LCDDATA20	S23C3	S22C3	S21C3	S20C3	S19C3	S18C3	S17C3	S16C3	49
LCDDATA19	S15C3	S14C3	S13C3	S12C3	S11C3	S10C3	S09C3	S08C3	49
LCDDATA18	S07C3	S06C3	S05C3	S04C3	S03C3	S02C3	S01C3	S00C3	49
LCDDATA16	—	—	—	—	—	—	—	S32C2	49
LCDDATA15	S31C2	S30C2	S29C2	S28C2	S27C2	S26C2	S25C2	S24C2	49
LCDDATA14	S23C2	S22C2	S21C2	S20C2	S19C2	S18C2	S17C2	S16C2	49
LCDDATA13	S15C2	S14C2	S13C2	S12C2	S11C2	S10C2	S09C2	S08C2	49
LCDDATA12	S07C2	S06C2	S05C2	S04C2	S03C2	S02C2	S01C2	S00C2	49
LCDDATA10	—	—	—	—	—	—	—	S32C1	49
LCDDATA9	S31C1	S30C1	S29C1	S28C1	S27C1	S26C1	S25C1	S24C1	49
LCDDATA8	S23C1	S22C1	S21C1	S20C1	S19C1	S18C1	S17C1	S16C1	49
LCDDATA7	S15C1	S14C1	S13C1	S12C1	S11C1	S10C1	S09C1	S08C1	49
LCDDATA6	S07C1	S06C1	S05C1	S04C1	S03C1	S02C1	S01C1	S00C1	49
LCDDATA4	—	—	—	—	—	—	—	S32C0	47
LCDDATA3	S31C0	S30C0	S29C0	S28C0	S27C0	S26C0	S25C0	S24C0	47
LCDDATA2	S23C0	S22C0	S21C0	S20C0	S19C0	S18C0	S17C0	S16C0	47
LCDDATA1	S15C0	S14C0	S13C0	S12C0	S11C0	S10C0	S09C0	S08C0	47
LCDDATA0	S07C0	S06C0	S05C0	S04C0	S03C0	S02C0	S01C0	S00C0	47
LCDSE4	—	—	—	—	—	—	—	SE32	47
LCDSE3	SE31	SE30	SE29	SE28	SE27	SE26	SE25	SE24	47
LCDSE2	SE23	SE22	SE21	SE20	SE19	SE18	SE17	SE16	47
LCDSE1	SE15	SE14	SE13	SE12	SE11	SE10	SE09	SE08	47
LCDSE0	SE07	SE06	SE05	SE04	SE03	SE02	SE01	SE00	47
LCDCON	LCDEN	SLPEN	WERR	—	CS1	CS0	LMUX1	LMUX0	47
LCDPS	WFT	BIASMD	LCDA	WA	LP3	LP2	LP1	LP0	47
LCDREG	—	CPEN	BIAS2	BIAS1	BIAS0	MODE13	CKSEL1	CKSEL0	46

Legend: — = unimplemented, read as '0'. Shaded cells are not used for LCD operation.

**Note 1:** These registers or individual bits are unimplemented on PIC18F86J72 devices.

**Note:** When the device enters Sleep mode while operating in Bias modes, M0 or M1, be sure that the bias capacitors are fully discharged in order to get the lowest Sleep current.

## 18.0 MASTER SYNCHRONOUS SERIAL PORT (MSSP) MODULE

### 18.1 Master SSP (MSSP) Module Overview

The Master Synchronous Serial Port (MSSP) module is a serial interface, useful for communicating with other peripheral or microcontroller devices. These peripheral devices may be serial EEPROMs, shift registers, display drivers, A/D Converters, etc. The MSSP module can operate in one of two modes:

- Serial Peripheral Interface (SPI)
- Inter-Integrated Circuit (I<sup>2</sup>C)
  - Full Master mode
  - Slave mode (with general address call)

The I<sup>2</sup>C interface supports the following modes in hardware:

- Master mode
- Multi-Master mode
- Slave mode

### 18.2 Control Registers

Each MSSP module has three associated control registers. These include a STATUS register (SSPSTAT) and two control registers (SSPCON1 and SSPCON2). The use of these registers and their individual bits differ significantly depending on whether the MSSP module is operated in SPI or I<sup>2</sup>C mode.

Additional details are provided under the individual sections.

### 18.3 SPI Mode

The SPI mode allows eight bits of data to be synchronously transmitted and received simultaneously. All four modes of SPI are supported. To accomplish communication, typically three pins are used:

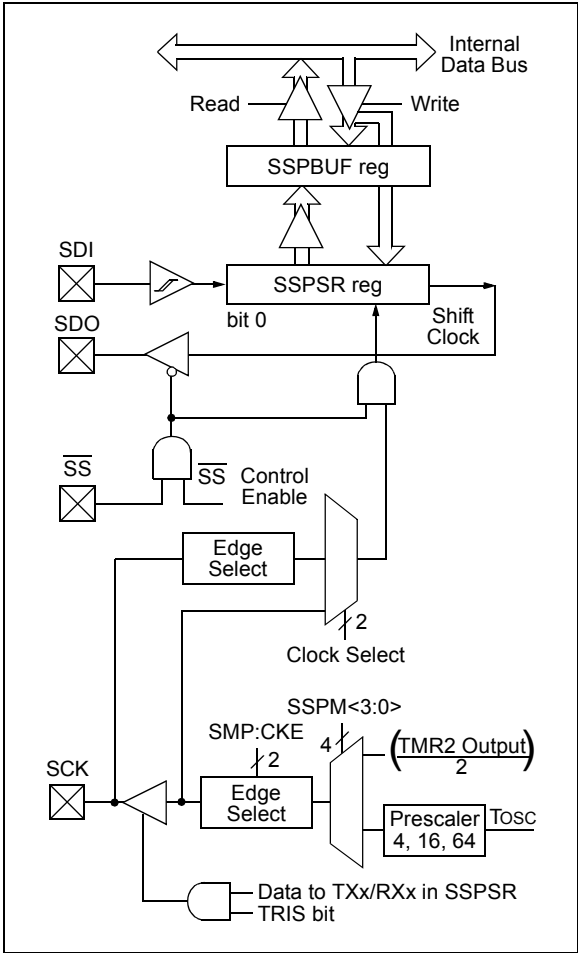
- Serial Data Out (SDO) – RC5/SDO/SEG12
- Serial Data In (SDI) – RC4/SDI/SDA/SEG16
- Serial Clock (SCK) – RC3/SCK/SCL/SEG17

Additionally, a fourth pin may be used when in a Slave mode of operation:

- Slave Select ( $\overline{SS}$ ) – RF7/AN5/ $\overline{SS}$ /SEG25

Figure 18-1 shows the block diagram of the MSSP module when operating in SPI mode.

**FIGURE 18-1: MSSP BLOCK DIAGRAM (SPI MODE)**



# PIC18F87J72

## 18.3.1 REGISTERS

Each MSSP module has four registers for SPI mode operation. These are:

- MSSP Control Register 1 (SSPCON1)
- MSSP STATUS Register (SSPSTAT)
- Serial Receive/Transmit Buffer Register (SSPBUF)
- MSSP Shift Register (SSPSR) – Not directly accessible

SSPCON1 and SSPSTAT are the control and STATUS registers in SPI mode operation. The SSPCON1 register is readable and writable. The lower six bits of the SSPSTAT are read-only. The upper two bits of the SSPSTAT are read/write.

SSPSR is the shift register used for shifting data in or out. SSPBUF is the buffer register to which data bytes are written to or read from.

In receive operations, SSPSR and SSPBUF together, create a double-buffered receiver. When SSPSR receives a complete byte, it is transferred to SSPBUF and the SSPIF interrupt is set.

During transmission, the SSPBUF is not double-buffered. A write to SSPBUF will write to both SSPBUF and SSPSR.

### REGISTER 18-1: SSPSTAT: MSSP STATUS REGISTER (SPI MODE)

R/W-0	R/W-0	R-0	R-0	R-0	R-0	R0	R-0
SMP	CKE <sup>(1)</sup>	D/Ā	P	S	R/W	UA	BF
bit 7						bit 0	

Legend:

R = Readable bit

W = Writable bit

U = Unimplemented bit, read as '0'

-n = Value at POR

'1' = Bit is set

'0' = Bit is cleared

x = Bit is unknown

bit 7

**SMP:** Sample bit

SPI Master mode:

1 = Input data sampled at end of data output time

0 = Input data sampled at middle of data output time

SPI Slave mode:

SMP must be cleared when SPI is used in Slave mode.

bit 6

**CKE:** SPI Clock Select bit<sup>(1)</sup>

1 = Transmit occurs on transition from active to Idle clock state

0 = Transmit occurs on transition from Idle to active clock state

bit 5

**D/Ā:** Data/Address bit

Used in I<sup>2</sup>C mode only.

bit 4

**P:** Stop bit

Used in I<sup>2</sup>C mode only. This bit is cleared when the MSSP module is disabled, SSPEN is cleared.

bit 3

**S:** Start bit

Used in I<sup>2</sup>C mode only.

bit 2

**R/W:** Read/Write Information bit

Used in I<sup>2</sup>C mode only.

bit 1

**UA:** Update Address bit

Used in I<sup>2</sup>C mode only.

bit 0

**BF:** Buffer Full Status bit (Receive mode only)

1 = Receive complete, SSPBUF is full

0 = Receive not complete, SSPBUF is empty

**Note 1:** Polarity of clock state is set by the CKP bit (SSPCON1<4>).

## REGISTER 18-2: SSPCON1: MSSP CONTROL REGISTER 1 (SPI MODE)

R/W-0	R/W-0	R/W-0	R/W-0	R/W-0	R/W-0	R/W-0	R/W-0
WCOL	SSPOV <sup>(1)</sup>	SSPEN <sup>(2)</sup>	CKP	SSPM3 <sup>(3)</sup>	SSPM2 <sup>(3)</sup>	SSPM1 <sup>(3)</sup>	SSPM0 <sup>(3)</sup>
bit 7							bit 0

### Legend:

R = Readable bit

W = Writable bit

U = Unimplemented bit, read as '0'

-n = Value at POR

'1' = Bit is set

'0' = Bit is cleared

x = Bit is unknown

- bit 7      **WCOL:** Write Collision Detect bit (Transmit mode only)  
           1 = The SSPBUF register is written while it is still transmitting the previous word (must be cleared in software)  
           0 = No collision
- bit 6      **SSPOV:** Receive Overflow Indicator bit<sup>(1)</sup>  
SPI Slave mode:  
           1 = A new byte is received while the SSPBUF register is still holding the previous data. In case of overflow, the data in SSPSR is lost. Overflow can only occur in Slave mode. The user must read the SSPBUF, even if only transmitting data, to avoid setting overflow (must be cleared in software).  
           0 = No overflow
- bit 5      **SSPEN:** Master Synchronous Serial Port Enable bit<sup>(2)</sup>  
           1 = Enables serial port and configures SCK, SDO, SDI and  $\overline{SS}$  as serial port pins  
           0 = Disables serial port and configures these pins as I/O port pins
- bit 4      **CKP:** Clock Polarity Select bit  
           1 = Idle state for clock is a high level  
           0 = Idle state for clock is a low level
- bit 3-0    **SSPM<3:0>:** Master Synchronous Serial Port Mode Select bits<sup>(3)</sup>  
           0101 = SPI Slave mode, clock = SCK pin,  $\overline{SS}$  pin control disabled,  $\overline{SS}$  can be used as an I/O pin  
           0100 = SPI Slave mode, clock = SCK pin,  $\overline{SS}$  pin control enabled  
           0011 = SPI Master mode, clock = TMR2 output/2  
           0010 = SPI Master mode, clock = Fosc/64  
           0001 = SPI Master mode, clock = Fosc/16  
           0000 = SPI Master mode, clock = Fosc/4

**Note 1:** In Master mode, the overflow bit is not set since each new reception (and transmission) is initiated by writing to the SSPBUF register.

**2:** When enabled, these pins must be properly configured as input or output.

**3:** Bit combinations not specifically listed here are either reserved or implemented in I<sup>2</sup>C mode only.

# PIC18F87J72

## 18.3.2 OPERATION

When initializing the SPI, several options need to be specified. This is done by programming the appropriate control bits (SSPCON1<5:0> and SSPSTAT<7:6>). These control bits allow the following to be specified:

- Master mode (SCK is the clock output)
- Slave mode (SCK is the clock input)
- Clock Polarity (Idle state of SCK)
- Data Input Sample Phase (middle or end of data output time)
- Clock Edge (output data on rising/falling edge of SCK)
- Clock Rate (Master mode only)
- Slave Select mode (Slave mode only)

Each MSSP consists of a transmit/receive shift register (SSPSR) and a buffer register (SSPBUF). The SSPSR shifts the data in and out of the device, MSb first. The SSPBUF holds the data that was written to the SSPSR until the received data is ready. Once the eight bits of data have been received, that byte is moved to the SSPBUF register. Then, the Buffer Full detect bit, BF (SSPSTAT<0>), and the interrupt flag bit, SSPIF, are set. This double-buffering of the received data (SSPBUF) allows the next byte to start reception before reading the data that was just received. Any write to the SSPBUF register during transmission/reception of data

will be ignored and the Write Collision detect bit, WCOL (SSPCON1<7>), will be set. User software must clear the WCOL bit so that it can be determined if the following write(s) to the SSPBUF register completed successfully.

When the application software is expecting to receive valid data, the SSPBUF should be read before the next byte of data to transfer is written to the SSPBUF. The Buffer Full bit, BF (SSPSTAT<0>), indicates when SSPBUF has been loaded with the received data (transmission is complete). When the SSPBUF is read, the BF bit is cleared. This data may be irrelevant if the SPI is only a transmitter. Generally, the MSSP interrupt is used to determine when the transmission/reception has completed. The SSPBUF must be read and/or written. If the interrupt method is not going to be used, then software polling can be done to ensure that a write collision does not occur. [Example 18-1](#) shows the loading of the SSPBUF (SSPSR) for data transmission.

**Note:** To prevent lost data in Master mode, read SSPBUF after each transmission to clear the BF bit.

The SSPSR is not directly readable or writable and can only be accessed by addressing the SSPBUF register. Additionally, the SSPSTAT register indicates the various status conditions.

### EXAMPLE 18-1: LOADING THE SSPBUF (SSPSR) REGISTER

```
LOOP   BTFSS   SSPSTAT, BF      ;Has data been received (transmit complete)?
        BRA    LOOP            ;No
        MOVF   SSPBUF, W        ;WREG reg = contents of SSPBUF
        MOVWF  RXDATA           ;Save in user RAM, if data is meaningful
        MOVF   TXDATA, W        ;W reg = contents of TXDATA
        MOVWF  SSPBUF           ;New data to xmit
```

### 18.3.3 ENABLING SPI I/O

To enable the serial port, MSSP Enable bit, SSPEN (SSPCON1<5>), must be set. To reset or reconfigure SPI mode, clear the SSPEN bit, reinitialize the SSPCON registers and then set the SSPEN bit. This configures the SDI, SDO, SCK and  $\overline{SS}$  pins as serial port pins. For the pins to behave as the serial port function, some must have their data direction bits (in the TRIS register) appropriately programmed as follows:

- SDI is automatically controlled by the SPI module
- SDO must have TRISC<5> bit cleared
- SCK (Master mode) must have TRISC<3> bit cleared
- SCK (Slave mode) must have TRISC<3> bit set
- $\overline{SS}$  must have TRISF<7> bit set

Any serial port function that is not desired may be overridden by programming the corresponding data direction (TRIS) register to the opposite value.

### 18.3.4 OPEN-DRAIN OUTPUT OPTION

The drivers for the SDO output and SCK clock pins can be optionally configured as open-drain outputs. This feature allows the voltage level on the pin to be pulled

to a higher level through an external pull-up resistor, and allows the output to communicate with external circuits without the need for additional level shifters.

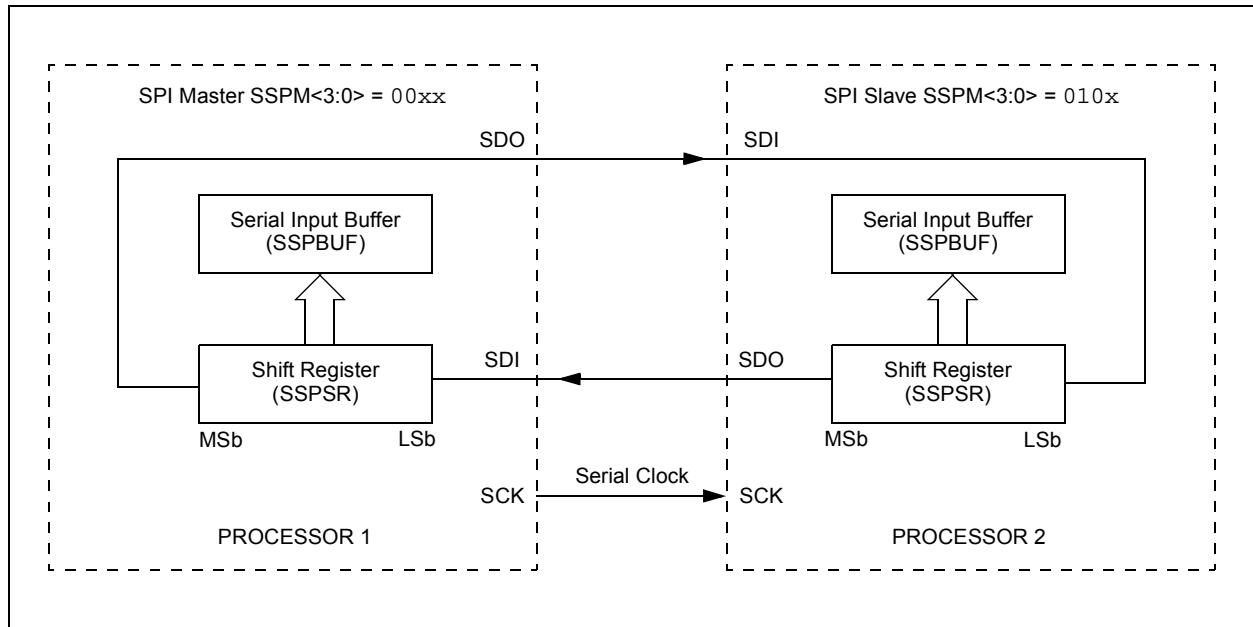
The open-drain output option is controlled by the SPIOD bit (TRISG<7>). Setting the bit configures both pins for open-drain operation.

### 18.3.5 TYPICAL CONNECTION

Figure 18-2 shows a typical connection between two microcontrollers. The master controller (Processor 1) initiates the data transfer by sending the SCK signal. Data is shifted out of both shift registers on their programmed clock edge and latched on the opposite edge of the clock. Both processors should be programmed to the same Clock Polarity (CKP), then both controllers would send and receive data at the same time. Whether the data is meaningful (or dummy data) depends on the application software. This leads to three scenarios for data transmission:

- Master sends data – Slave sends dummy data
- Master sends data – Slave sends data
- Master sends dummy data – Slave sends data

**FIGURE 18-2: SPI MASTER/SLAVE CONNECTION**



# PIC18F87J72

## 18.3.6 MASTER MODE

The master can initiate the data transfer at any time because it controls the SCK. The master determines when the slave (Processor 2, [Figure 18-2](#)) will broadcast data by the software protocol.

In Master mode, the data is transmitted/received as soon as the SSPBUF register is written to. If the SPI is only going to receive, the SDO output could be disabled (programmed as an input). The SSPSR register will continue to shift in the signal present on the SDI pin at the programmed clock rate. As each byte is received, it will be loaded into the SSPBUF register as if a normal received byte (interrupts and Status bits appropriately set). This could be useful in receiver applications as a “Line Activity Monitor” mode.

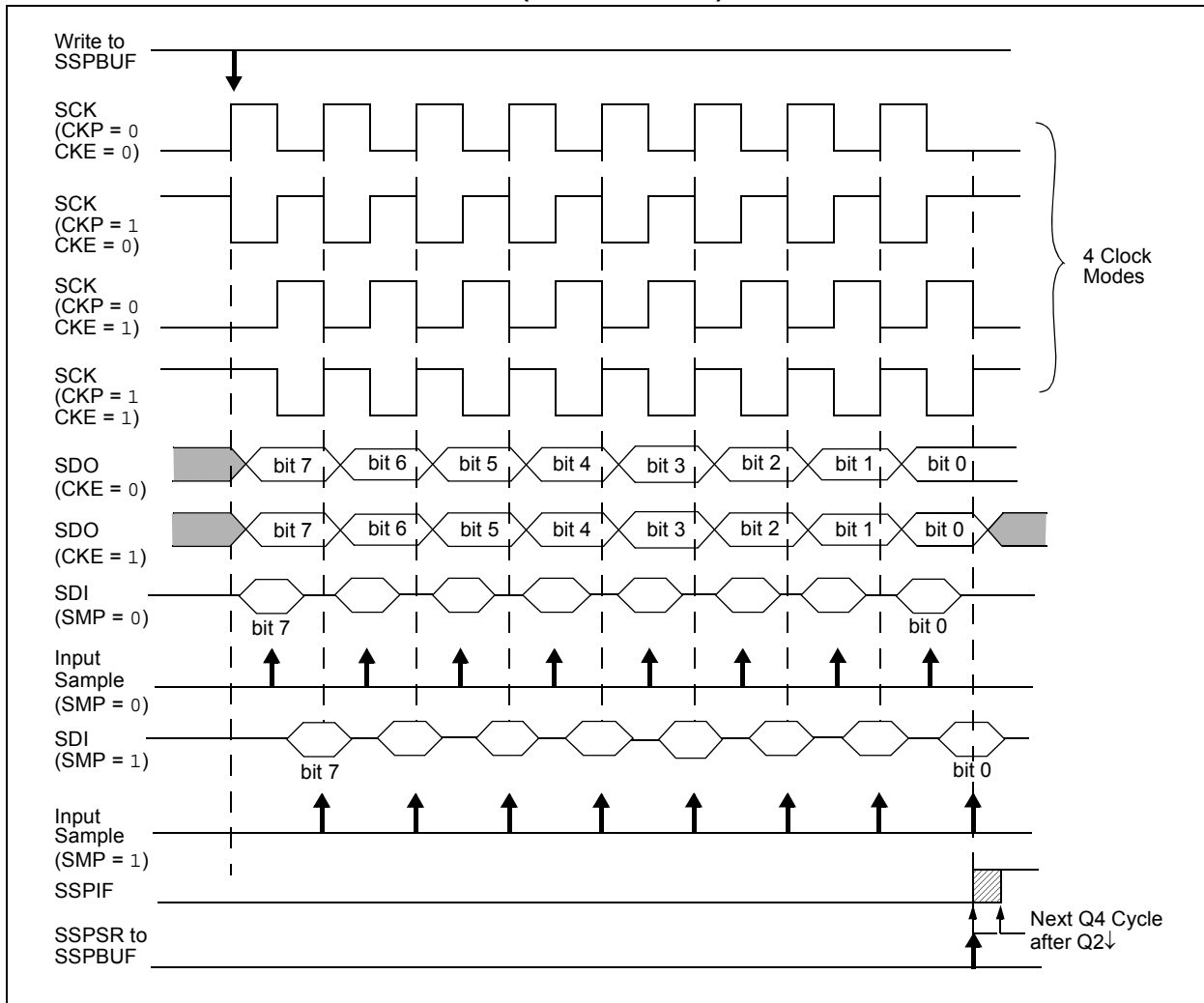
The clock polarity is selected by appropriately programming the CKP bit (SSPCON1<4>). This, then, would give waveforms for SPI communication as shown in [Figure 18-3](#), [Figure 18-5](#) and [Figure 18-6](#), where the MSB is transmitted first. In Master mode, the SPI clock rate (bit rate) is user-programmable to be one of the following:

- $F_{osc}/4$  (or  $T_{CY}$ )
- $F_{osc}/16$  (or  $4 \cdot T_{CY}$ )
- $F_{osc}/64$  (or  $16 \cdot T_{CY}$ )
- $Timer2\ output/2$

This allows a maximum data rate (at 40 MHz) of 10.00 Mbps.

[Figure 18-3](#) shows the waveforms for Master mode. When the CKE bit is set, the SDO data is valid before there is a clock edge on SCK. The change of the input sample is shown based on the state of the SMP bit. The time when the SSPBUF is loaded with the received data is shown.

**FIGURE 18-3: SPI MODE WAVEFORM (MASTER MODE)**





## 18.3.7 SLAVE MODE

In Slave mode, the data is transmitted and received as the external clock pulses appear on SCK. When the last bit is latched, the SSPIF interrupt flag bit is set.

Before enabling the module in SPI Slave mode, the clock line must match the proper Idle state. The clock line can be observed by reading the SCK pin. The Idle state is determined by the CKP bit (SSPCON1<4>).

While in Slave mode, the external clock is supplied by the external clock source on the SCK pin. This external clock must meet the minimum high and low times as specified in the electrical specifications.

While in Sleep mode, the slave can transmit/receive data. When a byte is received, the device will wake-up from Sleep.

## 18.3.8 SLAVE SELECT SYNCHRONIZATION

The  $\overline{SS}$  pin allows a Synchronous Slave mode. The SPI must be in Slave mode with  $\overline{SS}$  pin control enabled (SSPCON1<3:0> = 04h). When the  $\overline{SS}$  pin is low, transmission and reception are enabled and the SDO pin is

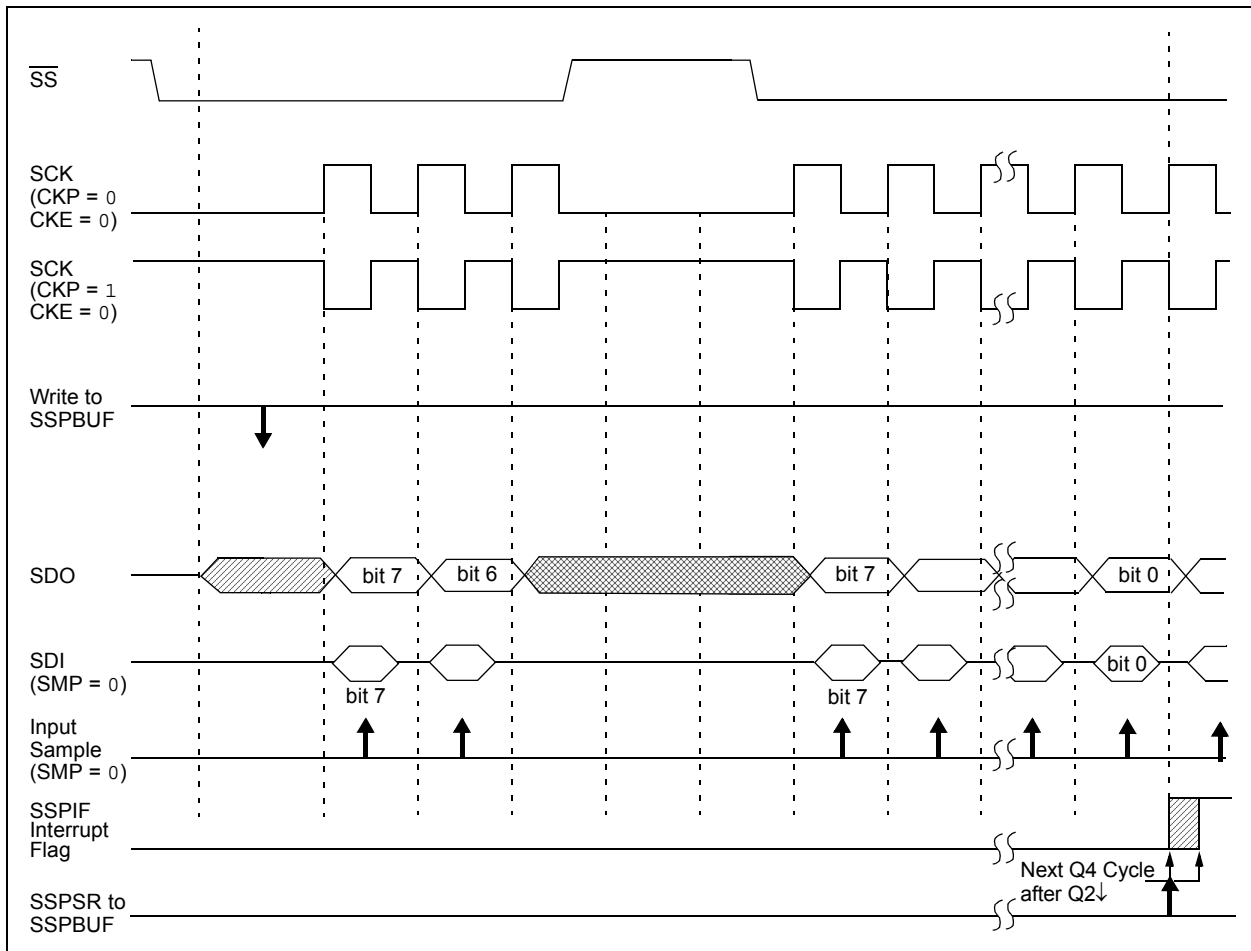
driven. When the  $\overline{SS}$  pin goes high, the SDO pin is no longer driven, even if in the middle of a transmitted byte and becomes a floating output. External pull-up/pull-down resistors may be desirable depending on the application.

- Note 1:** When the SPI is in Slave mode with  $\overline{SS}$  pin control enabled (SSPCON1<3:0> = 0100), the SPI module will reset if the  $\overline{SS}$  pin is set to VDD.
- 2:** If the SPI is used in Slave mode with CKE set, then the  $\overline{SS}$  pin control must be enabled.

When the SPI module resets, the bit counter is forced to '0'. This can be done by either forcing the  $\overline{SS}$  pin to a high level or clearing the SSPEN bit.

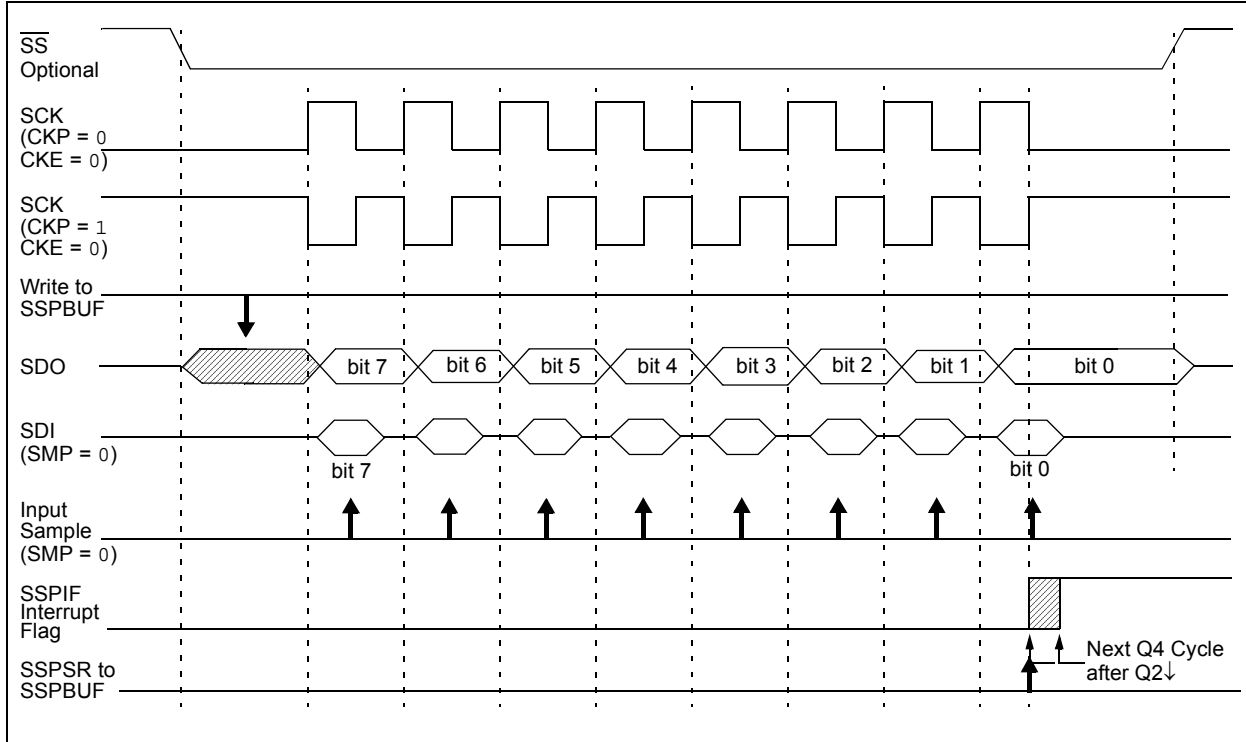
To emulate two-wire communication, the SDO pin can be connected to the SDI pin. When the SPI needs to operate as a receiver, the SDO pin can be configured as an input. This disables transmissions from the SDO. The SDI can always be left as an input (SDI function) since it cannot create a bus conflict.

**FIGURE 18-4: SLAVE SYNCHRONIZATION WAVEFORM**

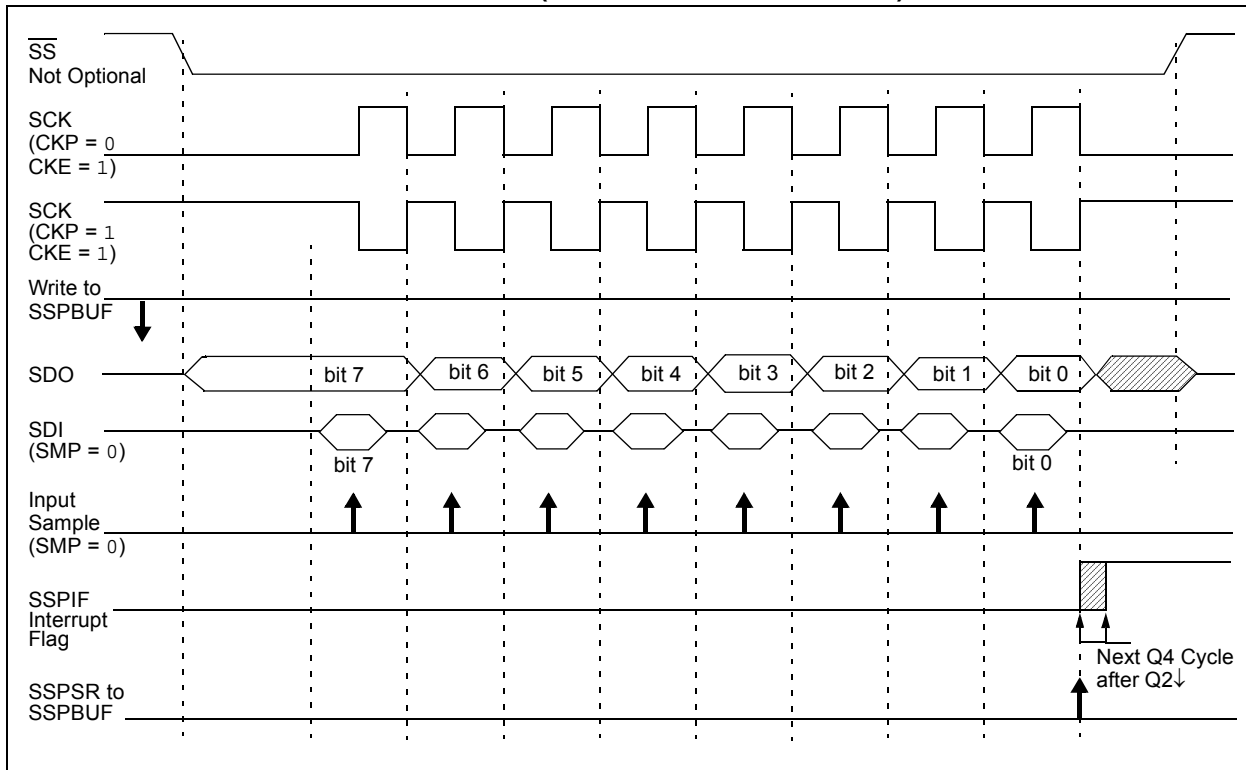


# PIC18F87J72

**FIGURE 18-5: SPI MODE WAVEFORM (SLAVE MODE WITH CKE = 0)**



**FIGURE 18-6: SPI MODE WAVEFORM (SLAVE MODE WITH CKE = 1)**



## 18.3.9 OPERATION IN POWER-MANAGED MODES

In SPI Master mode, module clocks may be operating at a different speed than when in Full-Power mode; in the case of Sleep mode, all clocks are halted.

In Idle modes, a clock is provided to the peripherals. That clock should be from the primary clock source, the secondary clock (Timer1 oscillator at 32.768 kHz) or the INTRC source. See [Section 3.3 “Clock Sources and Oscillator Switching”](#) for additional information.

In most cases, the speed that the master clocks SPI data is not important; however, this should be evaluated for each system.

If MSSP interrupts are enabled, they can wake the controller from Sleep mode, or one of the Idle modes, when the master completes sending data. If an exit from Sleep or Idle mode is not desired, MSSP interrupts should be disabled.

If the Sleep mode is selected, all module clocks are halted and the transmission/reception will remain in that state until the device wakes. After the device returns to Run mode, the module will resume transmitting and receiving data.

In SPI Slave mode, the SPI Transmit/Receive Shift register operates asynchronously to the device. This allows the device to be placed in any power-managed mode and data to be shifted into the SPI

Transmit/Receive Shift register. When all eight bits have been received, the MSSP interrupt flag bit will be set, and if enabled, will wake the device.

## 18.3.10 EFFECTS OF A RESET

A Reset disables the MSSP module and terminates the current transfer.

## 18.3.11 BUS MODE COMPATIBILITY

[Table 18-1](#) shows the compatibility between the standard SPI modes and the states of the CKP and CKE control bits.

There is also an SMP bit which controls when the data is sampled.

**TABLE 18-1: SPI BUS MODES**

Standard SPI Mode Terminology	Control Bits State	
	CKP	CKE
0, 0 <sup>(1)</sup>	0	1
0, 1	0	0
1, 0	1	1
1, 1 <sup>(1)</sup>	1	0

**Note 1:** Use one of these modes when using the SPI to communicate with the AFE. See [Section 22.5 “Using the AFE”](#) for more information.

**TABLE 18-2: REGISTERS ASSOCIATED WITH SPI OPERATION**

Name	Bit 7	Bit 6	Bit 5	Bit 4	Bit 3	Bit 2	Bit 1	Bit 0	Reset Values on page
INTCON	GIE/GIEH	PEIE/GIEL	TMR0IE	INT0IE	RBIE	TMR0IF	INT0IF	RBIF	45
PIR1	—	ADIF	RC1IF	TX1IF	SSPIF	—	TMR2IF	TMR1IF	48
PIE1	—	ADIE	RC1IE	TX1IE	SSPIE	—	TMR2IE	TMR1IE	48
IPR1	—	ADIP	RC1IP	TX1IP	SSPIP	—	TMR2IP	TMR1IP	48
TRISC	TRISC7	TRISC6	TRISC5	TRISC4	TRISC3	TRISC2	TRISC1	TRISC0	48
TRISF	TRISF7	TRISF6	TRISF5	TRISF4	TRISF3	TRISF2	TRISF1	—	48
TRISG	SPIOD	CCP2OD	CCP1OD	TRISG4	TRISG3	TRISG2	TRISG1	TRISG0	48
SSPBUF	MSSP Receive Buffer/Transmit Register								46
SSPCON1	WCOL	SSPOV	SSPEN	CKP	SSPM3	SSPM2	SSPM1	SSPM0	46
SSPSTAT	SMP	CKE	D/A	P	S	R/W	UA	BF	46

Legend: Shaded cells are not used by the MSSP module in SPI mode.

# PIC18F87J72

## 18.4 I<sup>2</sup>C Mode

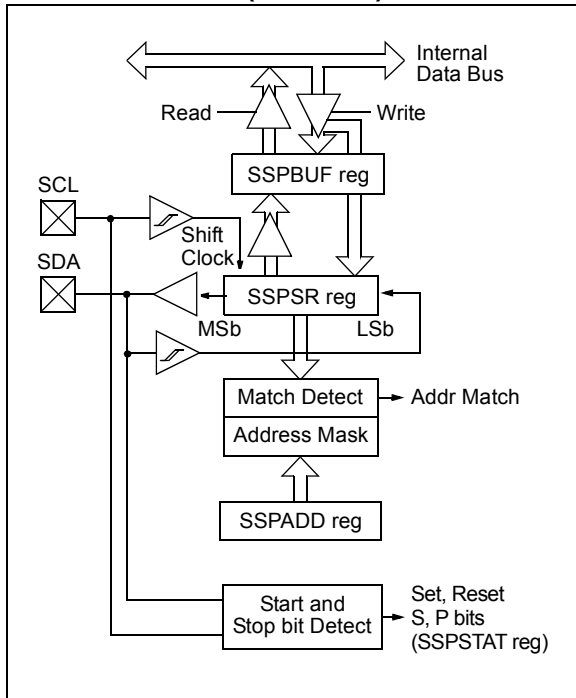
The MSSP module in I<sup>2</sup>C mode fully implements all master and slave functions (including general call support) and provides interrupts on Start and Stop bits in hardware to determine a free bus (multi-master function). The MSSP module implements the standard mode specifications as well as 7-bit and 10-bit addressing.

Two pins are used for data transfer:

- Serial clock (SCL) – RC3/SCK/SCL/SEG17
- Serial data (SDA) – RC4/SDI/SDA/SEG16

The user must configure these pins as inputs by setting the TRISC<4:3> bits.

**FIGURE 18-7: MSSP BLOCK DIAGRAM (I<sup>2</sup>C MODE)**



### 18.4.1 REGISTERS

The MSSP module has six registers for I<sup>2</sup>C operation. These are:

- MSSP Control Register 1 (SSPCON1)
- MSSP Control Register 2 (SSPCON2)
- MSSP STATUS Register (SSPSTAT)
- Serial Receive/Transmit Buffer Register (SSPBUF)
- MSSP Shift Register (SSPSR) – Not directly accessible
- MSSP Address Register (SSPADD)

SSPCON1, SSPCON2 and SSPSTAT are the control and STATUS registers in I<sup>2</sup>C mode operation. The SSPCON1 and SSPCON2 registers are readable and writable. The lower six bits of the SSPSTAT are read-only. The upper two bits of the SSPSTAT are read/write.

Many of the bits in SSPCON2 assume different functions, depending on whether the module is operating in Master or Slave mode; bits<5:2> also assume different names in Slave mode. The different aspects of SSPCON2 are shown in [Register 18-5](#) (for Master mode) and [Register 18-6](#) (Slave mode).

SSPSR is the shift register used for shifting data in or out. SSPBUF is the buffer register to which data bytes are written to or read from.

SSPADD register holds the slave device address when the MSSP is configured in I<sup>2</sup>C Slave mode. When the MSSP is configured in Master mode, the lower seven bits of SSPADD act as the Baud Rate Generator reload value.

In receive operations, SSPSR and SSPBUF together, create a double-buffered receiver. When SSPSR receives a complete byte, it is transferred to SSPBUF and the SSPIF interrupt is set.

During transmission, the SSPBUF is not double-buffered. A write to SSPBUF will write to both SSPBUF and SSPSR.

## REGISTER 18-3: SSPSTAT: MSSP STATUS REGISTER (I<sup>2</sup>C MODE)

R/W-0	R/W-0	R-0	R-0	R-0	R-0	R-0	R-0
SMP	CKE	D/ $\bar{A}$	P <sup>(1)</sup>	S <sup>(1)</sup>	R/ $\bar{W}$	UA	BF
bit 7							bit 0

### Legend:

R = Readable bit	W = Writable bit	U = Unimplemented bit, read as '0'
-n = Value at POR	'1' = Bit is set	'0' = Bit is cleared
		x = Bit is unknown

- bit 7      **SMP:** Slew Rate Control bit  
In Master or Slave mode:  
 1 = Slew rate control disabled for Standard Speed mode (100 kHz and 1 MHz)  
 0 = Slew rate control enabled for High-Speed mode (400 kHz)
- bit 6      **CKE:** SMBus Select bit  
In Master or Slave mode:  
 1 = Enable SMBus specific inputs  
 0 = Disable SMBus specific inputs
- bit 5      **D/ $\bar{A}$ :** Data/Address bit  
In Master mode:  
 Reserved.  
In Slave mode:  
 1 = Indicates that the last byte received or transmitted was data  
 0 = Indicates that the last byte received or transmitted was address
- bit 4      **P:** Stop bit<sup>(1)</sup>  
 1 = Indicates that a Stop bit has been detected last  
 0 = Stop bit was not detected last
- bit 3      **S:** Start bit<sup>(1)</sup>  
 1 = Indicates that a Start bit has been detected last  
 0 = Start bit was not detected last
- bit 2      **R/ $\bar{W}$ :** Read/Write Information bit (I<sup>2</sup>C mode only)  
In Slave mode:<sup>(2)</sup>  
 1 = Read  
 0 = Write  
In Master mode:<sup>(3)</sup>  
 1 = Transmit is in progress  
 0 = Transmit is not in progress
- bit 1      **UA:** Update Address bit (10-Bit Slave mode only)  
 1 = Indicates that the user needs to update the address in the SSPADD register  
 0 = Address does not need to be updated
- bit 0      **BF:** Buffer Full Status bit  
In Transmit mode:  
 1 = SSPBUF is full  
 0 = SSPBUF is empty  
In Receive mode:  
 1 = SSPBUF is full (does not include the  $\bar{ACK}$  and Stop bits)  
 0 = SSPBUF is empty (does not include the  $\bar{ACK}$  and Stop bits)

- Note 1:** This bit is cleared on Reset and when SSPEN is cleared.
- Note 2:** This bit holds the R/ $\bar{W}$  bit information following the last address match. This bit is only valid from the address match to the next Start bit, Stop bit or not  $\bar{ACK}$  bit.
- Note 3:** ORing this bit with SEN, RSEN, PEN, RCEN or ACKEN will indicate if the MSSP is in Active mode.

# PIC18F87J72

## REGISTER 18-4: SSPCON1: MSSP CONTROL REGISTER 1 (I<sup>2</sup>C MODE)

R/W-0	R/W-0	R/W-0	R/W-0	R/W-0	R/W-0	R/W-0	R/W-0
WCOL	SSPOV	SSPEN <sup>(1)</sup>	CKP	SSPM3	SSPM2	SSPM1	SSPM0
bit 7							bit 0

### Legend:

R = Readable bit                      W = Writable bit                      U = Unimplemented bit, read as '0'  
 -n = Value at POR                      '1' = Bit is set                      '0' = Bit is cleared                      x = Bit is unknown

- bit 7                      **WCOL:** Write Collision Detect bit  
In Master Transmit mode:  
 1 = A write to the SSPBUF register is attempted while the I<sup>2</sup>C conditions are not valid for a transmission to be started (must be cleared in software)  
 0 = No collision  
In Slave Transmit mode:  
 1 = The SSPBUF register is written while it was still transmitting the previous word (must be cleared in software)  
 0 = No collision  
In Receive mode (Master or Slave modes):  
 This is a "don't care" bit.
- bit 6                      **SSPOV:** Receive Overflow Indicator bit  
In Receive mode:  
 1 = A byte is received while the SSPBUF register is still holding the previous byte (must be cleared in software)  
 0 = No overflow  
In Transmit mode:  
 This is a "don't care" bit in Transmit mode.
- bit 5                      **SSPEN:** Master Synchronous Serial Port Enable bit<sup>(1)</sup>  
 1 = Enables the serial port and configures the SDA and SCL pins as the serial port pins  
 0 = Disables serial port and configures these pins as I/O port pins
- bit 4                      **CKP:** SCK Release Control bit  
In Slave mode:  
 1 = Releases clock  
 0 = Holds clock low (clock stretch); used to ensure data setup time  
In Master mode:  
 Unused in this mode.
- bit 3-0                      **SSPM<3:0>:** Synchronous Serial Port Mode Select bits  
 1111 = I<sup>2</sup>C Slave mode, 10-bit address with Start and Stop bit interrupts enabled  
 1110 = I<sup>2</sup>C Slave mode, 7-bit address with Start and Stop bit interrupts enabled  
 1011 = I<sup>2</sup>C Firmware Controlled Master mode (slave Idle)  
 1000 = I<sup>2</sup>C Master mode, clock = Fosc/(4 \* (SSPADD + 1))  
 0111 = I<sup>2</sup>C Slave mode, 10-bit address  
 0110 = I<sup>2</sup>C Slave mode, 7-bit address  
 Bit combinations not specifically listed here are either reserved or implemented in SPI mode only.

**Note 1:** When enabled, the SDA and SCL pins must be configured as inputs.

## REGISTER 18-5: SSPCON2: MSSP CONTROL REGISTER 2 (I<sup>2</sup>C MASTER MODE)

R/W-0	R/W-0	R/W-0	R/W-0	R/W-0	R/W-0	R/W-0	R/W-0
GCEN	ACKSTAT	ACKDT <sup>(1)</sup>	ACKEN <sup>(2)</sup>	RCEN <sup>(2)</sup>	PEN <sup>(2)</sup>	RSEN <sup>(2)</sup>	SEN <sup>(2)</sup>
bit 7							bit 0

### Legend:

R = Readable bit

W = Writable bit

U = Unimplemented bit, read as '0'

-n = Value at POR

'1' = Bit is set

'0' = Bit is cleared

x = Bit is unknown

- bit 7      **GCEN:** General Call Enable bit  
Unused in Master mode.
- bit 6      **ACKSTAT:** Acknowledge Status bit (Master Transmit mode only)  
1 = Acknowledge was not received from slave  
0 = Acknowledge was received from slave
- bit 5      **ACKDT:** Acknowledge Data bit (Master Receive mode only)<sup>(1)</sup>  
1 = Not Acknowledge  
0 = Acknowledge
- bit 4      **ACKEN:** Acknowledge Sequence Enable bit<sup>(2)</sup>  
1 = Initiate Acknowledge sequence on SDA and SCL pins and transmit ACKDT data bit. Automatically cleared by hardware.  
0 = Acknowledge sequence Idle
- bit 3      **RCEN:** Receive Enable bit (Master Receive mode only)<sup>(2)</sup>  
1 = Enables Receive mode for I<sup>2</sup>C  
0 = Receive Idle
- bit 2      **PEN:** Stop Condition Enable bit<sup>(2)</sup>  
1 = Initiate Stop condition on SDA and SCL pins. Automatically cleared by hardware.  
0 = Stop condition Idle
- bit 1      **RSEN:** Repeated Start Condition Enable bit<sup>(2)</sup>  
1 = Initiate Repeated Start condition on SDA and SCL pins. Automatically cleared by hardware.  
0 = Repeated Start condition Idle
- bit 0      **SEN:** Start Condition Enable bit<sup>(2)</sup>  
1 = Initiate Start condition on SDA and SCL pins. Automatically cleared by hardware.  
0 = Start condition Idle

**Note 1:** Value that will be transmitted when the user initiates an Acknowledge sequence at the end of a receive.

**Note 2:** If the I<sup>2</sup>C module is active, these bits may not be set (no spooling) and the SSPBUF may not be written (or writes to the SSPBUF are disabled).

# PIC18F87J72

## REGISTER 18-6: SSPCON2: MSSP CONTROL REGISTER 2 (I<sup>2</sup>C SLAVE MODE)

R/W-0	R/W-0	R/W-0	R/W-0	R/W-0	R/W-0	R/W-0	R/W-0
GCEN	ACKSTAT	ADMSK5	ADMSK4	ADMSK3	ADMSK2	ADMSK1	SEN <sup>(1)</sup>
bit 7							bit 0

Legend:

R = Readable bit

W = Writable bit

U = Unimplemented bit, read as '0'

-n = Value at POR

'1' = Bit is set

'0' = Bit is cleared

x = Bit is unknown

- bit 7      **GCEN:** General Call Enable bit  
1 = Enable interrupt when a general call address (0000h) is received in the SSPSR  
0 = General call address disabled
- bit 6      **ACKSTAT:** Acknowledge Status bit  
Unused in Slave mode.
- bit 5-2    **ADMSK<5:2>:** Slave Address Mask Select bits  
1 = Masking of corresponding bits of SSPADD is enabled  
0 = Masking of corresponding bits of SSPADD is disabled
- bit 1      **ADMSK1:** Slave Address Least Significant bit(s) Mask Select bit  
In 7-Bit Addressing mode:  
1 = Masking of SSPADD<1> only is enabled  
0 = Masking of SSPADD<1> only is disabled  
In 10-Bit Addressing mode:  
1 = Masking of SSPADD<1:0> is enabled  
0 = Masking of SSPADD<1:0> is disabled
- bit 0      **SEN:** Stretch Enable bit<sup>(1)</sup>  
1 = Clock stretching is enabled for both slave transmit and slave receive (stretch enabled)  
0 = Clock stretching is disabled

**Note 1:** If the I<sup>2</sup>C module is active, this bit may not be set (no spooling) and the SSPBUF may not be written (or writes to the SSPBUF are disabled).



## 18.4.2 OPERATION

The MSSP module functions are enabled by setting the MSSP Enable bit, SSPEN (SSPCON1<5>).

The SSPCON1 register allows control of the I<sup>2</sup>C operation. Four mode selection bits (SSPCON1<3:0>) allow one of the following I<sup>2</sup>C modes to be selected:

- I<sup>2</sup>C Master mode,  
clock = (FOSC/4) x (SSPADD + 1)
- I<sup>2</sup>C Slave mode (7-bit address)
- I<sup>2</sup>C Slave mode (10-bit address)
- I<sup>2</sup>C Slave mode (7-bit address) with Start and Stop bit interrupts enabled
- I<sup>2</sup>C Slave mode (10-bit address) with Start and Stop bit interrupts enabled
- I<sup>2</sup>C Firmware Controlled Master mode,  
slave is Idle

Selection of any I<sup>2</sup>C mode, with the SSPEN bit set, forces the SCL and SDA pins to be open-drain, provided these pins are programmed to inputs by setting the appropriate TRISC or TRISD bits. To ensure proper operation of the module, pull-up resistors must be provided externally to the SCL and SDA pins.

## 18.4.3 SLAVE MODE

In Slave mode, the SCL and SDA pins must be configured as inputs (TRISC<4:3> set). The MSSP module will override the input state with the output data when required (slave-transmitter).

The I<sup>2</sup>C Slave mode hardware will always generate an interrupt on an exact address match. In addition, address masking will also allow the hardware to generate an interrupt for more than one address (up to 31 in 7-bit addressing and up to 63 in 10-bit addressing). Through the mode select bits, the user can also choose to interrupt on Start and Stop bits.

When an address is matched, or the data transfer after an address match is received, the hardware automatically will generate the Acknowledge (ACK) pulse and load the SSPBUF register with the received value currently in the SSPSR register.

Any combination of the following conditions will cause the MSSP module not to give this ACK pulse:

- The Buffer Full bit, BF (SSPSTAT<0>), was set before the transfer was received.
- The overflow bit, SSPOV (SSPCON1<6>), was set before the transfer was received.

In this case, the SSPSR register value is not loaded into the SSPBUF, but bit, SSPIF, is set. The BF bit is cleared by reading the SSPBUF register, while bit, SSPOV, is cleared through software.

The SCL clock input must have a minimum high and low for proper operation. The high and low times of the I<sup>2</sup>C specification, as well as the requirement of the MSSP module, are shown in timing Parameter 100 and Parameter 101.

### 18.4.3.1 Addressing

Once the MSSP module has been enabled, it waits for a Start condition to occur. Following the Start condition, the eight bits are shifted into the SSPSR register. All incoming bits are sampled with the rising edge of the clock (SCL) line. The value of register, SSPSR<7:1>, is compared to the value of the SSPADD register. The address is compared on the falling edge of the eighth clock (SCL) pulse. If the addresses match and the BF and SSPOV bits are clear, the following events occur:

1. The SSPSR register value is loaded into the SSPBUF register.
2. The Buffer Full bit, BF, is set.
3. An ACK pulse is generated.
4. The MSSP Interrupt Flag bit, SSPIF, is set (and interrupt is generated, if enabled) on the falling edge of the ninth SCL pulse.

In 10-Bit Addressing mode, two address bytes need to be received by the slave. The five Most Significant bits (MSBs) of the first address byte specify if this is a 10-bit address. Bit, R/W (SSPSTAT<2>), must specify a write so the slave device will receive the second address byte. For a 10-bit address, the first byte would equal '11110 A9 A8 0', where 'A9' and 'A8' are the two MSBs of the address. The sequence of events for 10-bit addressing is as follows, with steps 7 through 9 for the slave-transmitter:

1. Receive first (high) byte of address (SSPIF, BF and UA bits (SSPSTAT<1>) are set).
2. Update the SSPADD register with second (low) byte of address (clears UA bit and releases the SCL line).
3. Read the SSPBUF register (clears BF bit) and clear flag bit, SSPIF.
4. Receive second (low) byte of address (SSPIF, BF and UA bits are set).
5. Update the SSPADD register with the first (high) byte of address. If match releases SCL line, this will clear UA bit.
6. Read the SSPBUF register (clears BF bit) and clear flag bit, SSPIF.
7. Receive Repeated Start condition.
8. Receive first (high) byte of address (SSPIF and BF bits are set).
9. Read the SSPBUF register (clears BF bit) and clear flag bit, SSPIF.

# PIC18F87J72

## 18.4.3.2 Address Masking

Masking an address bit causes that bit to become a “don’t care”. When one address bit is masked, two addresses will be Acknowledged and cause an interrupt. It is possible to mask more than one address bit at a time, which makes it possible to Acknowledge up to 31 addresses in 7-bit mode and up to 63 addresses in 10-bit mode (see [Example 18-2](#)).

The I<sup>2</sup>C Slave behaves the same way whether address masking is used or not. However, when address masking is used, the I<sup>2</sup>C slave can Acknowledge multiple addresses and cause interrupts. When this occurs, it is necessary to determine which address caused the interrupt by checking SSPBUF.

In 7-Bit Addressing mode, Address Mask bits, ADMSK<5:1> (SSPCON<5:1>), mask the corresponding address bits in the SSPADD register. For any ADMSK bits that are set (ADMSK<x> = 1), the corresponding address bit is ignored (SSPADD<x> = x). For the module to issue an address Acknowledge, it is sufficient to match only on addresses that do not have an active address mask.

In 10-Bit Addressing mode, ADMSK<5:2> bits mask the corresponding address bits in the SSPADD register. In addition, ADMSK1 simultaneously masks the two LSBs of the address (SSPADD<1:0>). For any ADMSK bits that are active (ADMSK<x> = 1), the corresponding address bit is ignored (SSPADD<x> = x). Also note, that although in 10-Bit Addressing mode, the upper address bits reuse part of the SSPADD register bits; the address mask bits do not interact with those bits. They only affect the lower address bits.

**Note 1:** ADMSK1 masks the two Least Significant bits of the address.

**2:** The two Most Significant bits of the address are not affected by address masking.

### EXAMPLE 18-2: ADDRESS MASKING EXAMPLES

#### 7-Bit Addressing:

SSPADD<7:1> = A0h (1010000) (SSPADD<0> is assumed to be '0')

ADMSK<5:1> = 00111

Addresses Acknowledged: A0h, A2h, A4h, A6h, A8h, AAh, ACh, AEh

#### 10-Bit Addressing:

SSPADD<7:0> = A0h (10100000) (the two MSBs of the address are ignored in this example, since they are not affected by masking)

ADMSK<5:1> = 00111

Addresses Acknowledged: A0h, A1h, A2h, A3h, A4h, A5h, A6h, A7h, A8h, A9h, AAh, ABh, ACh, ADh, AEh, AFh

### 18.4.3.3 Reception

When the  $\overline{R/W}$  bit of the address byte is clear and an address match occurs, the  $\overline{R/W}$  bit of the SSPSTAT register is cleared. The received address is loaded into the SSPBUF register and the SDA line is held low ( $\overline{ACK}$ ).

When the address byte overflow condition exists, then the no Acknowledge ( $\overline{ACK}$ ) pulse is given. An overflow condition is defined as either bit, BF (SSPSTAT<0>), is set or bit, SSPOV (SSPCON1<6>), is set.

An MSSP interrupt is generated for each data transfer byte. The interrupt flag bit, SSPIF, must be cleared in software. The SSPSTAT register is used to determine the status of the byte.

If SEN is enabled (SSPCON2<0> = 1), SCK/SCL will be held low (clock stretch) following each data transfer. The clock must be released by setting bit, CKP (SSPCON1<4>). See [Section 18.4.4 “Clock Stretching”](#) for more details.

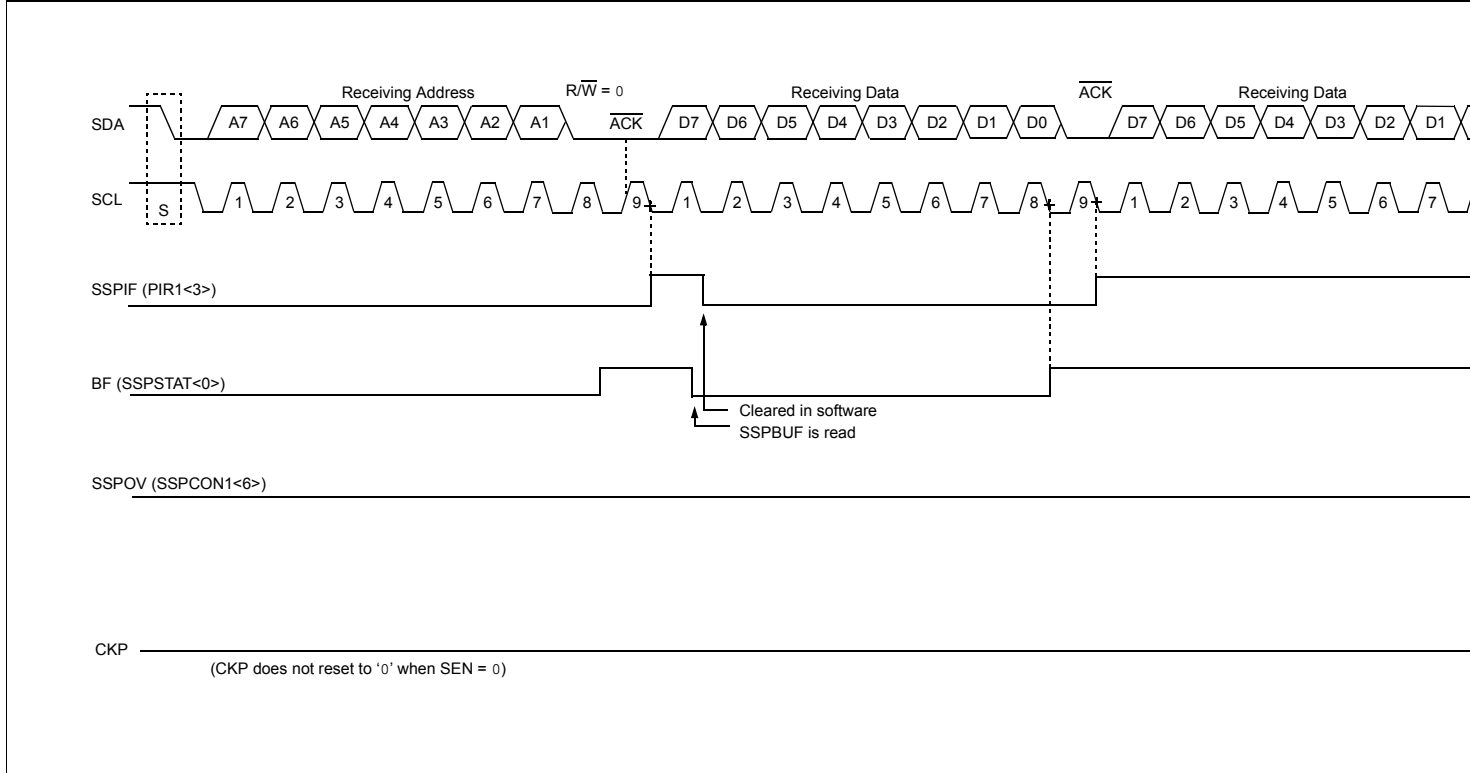
### 18.4.3.4 Transmission

When the  $\overline{R/W}$  bit of the incoming address byte is set and an address match occurs, the  $\overline{R/W}$  bit of the SSPSTAT register is set. The received address is loaded into the SSPBUF register. The  $\overline{ACK}$  pulse will be sent on the ninth bit and pin, RC3, is held low, regardless of SEN (see [Section 18.4.4 “Clock Stretching”](#) for more details). By stretching the clock, the master will be unable to assert another clock pulse until the slave is done preparing the transmit data. The transmit data must be loaded into the SSPBUF register which also loads the SSPSR register. Then, the RC3 pin should be enabled by setting bit, CKP (SSPCON1<4>). The eight data bits are shifted out on the falling edge of the SCL input. This ensures that the SDA signal is valid during the SCL high time ([Figure 18-10](#)).

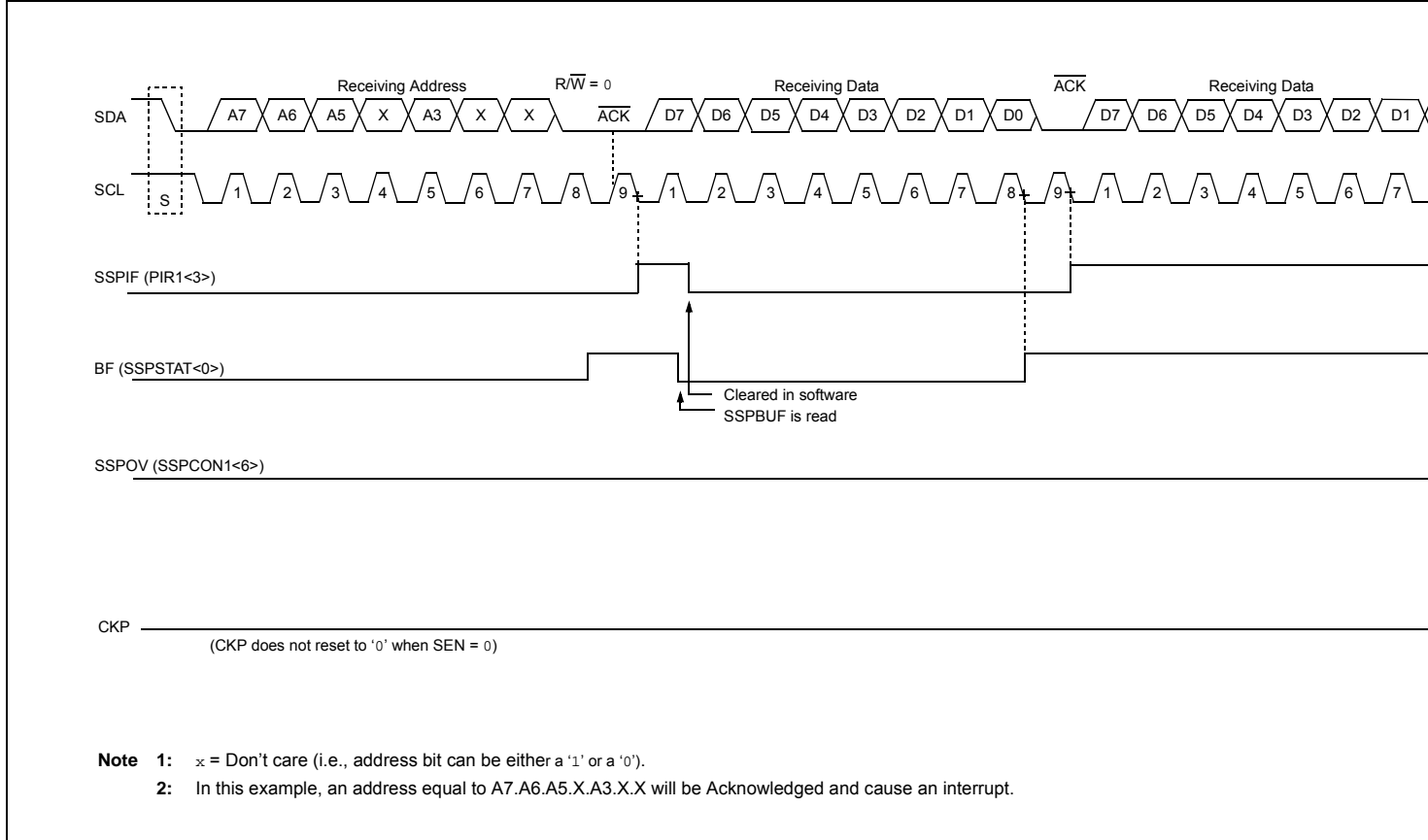
The  $\overline{ACK}$  pulse from the master-receiver is latched on the rising edge of the ninth SCL input pulse. If the SDA line is high (not  $\overline{ACK}$ ), then the data transfer is complete. In this case, when the  $\overline{ACK}$  is latched by the slave, the slave logic is reset and the slave monitors for another occurrence of the Start bit. If the SDA line was low ( $\overline{ACK}$ ), the next transmit data must be loaded into the SSPBUF register. Again, pin, RC3, must be enabled by setting bit, CKP.

An MSSP interrupt is generated for each data transfer byte. The SSPIF bit must be cleared in software and the SSPSTAT register is used to determine the status of the byte. The SSPIF bit is set on the falling edge of the ninth clock pulse.

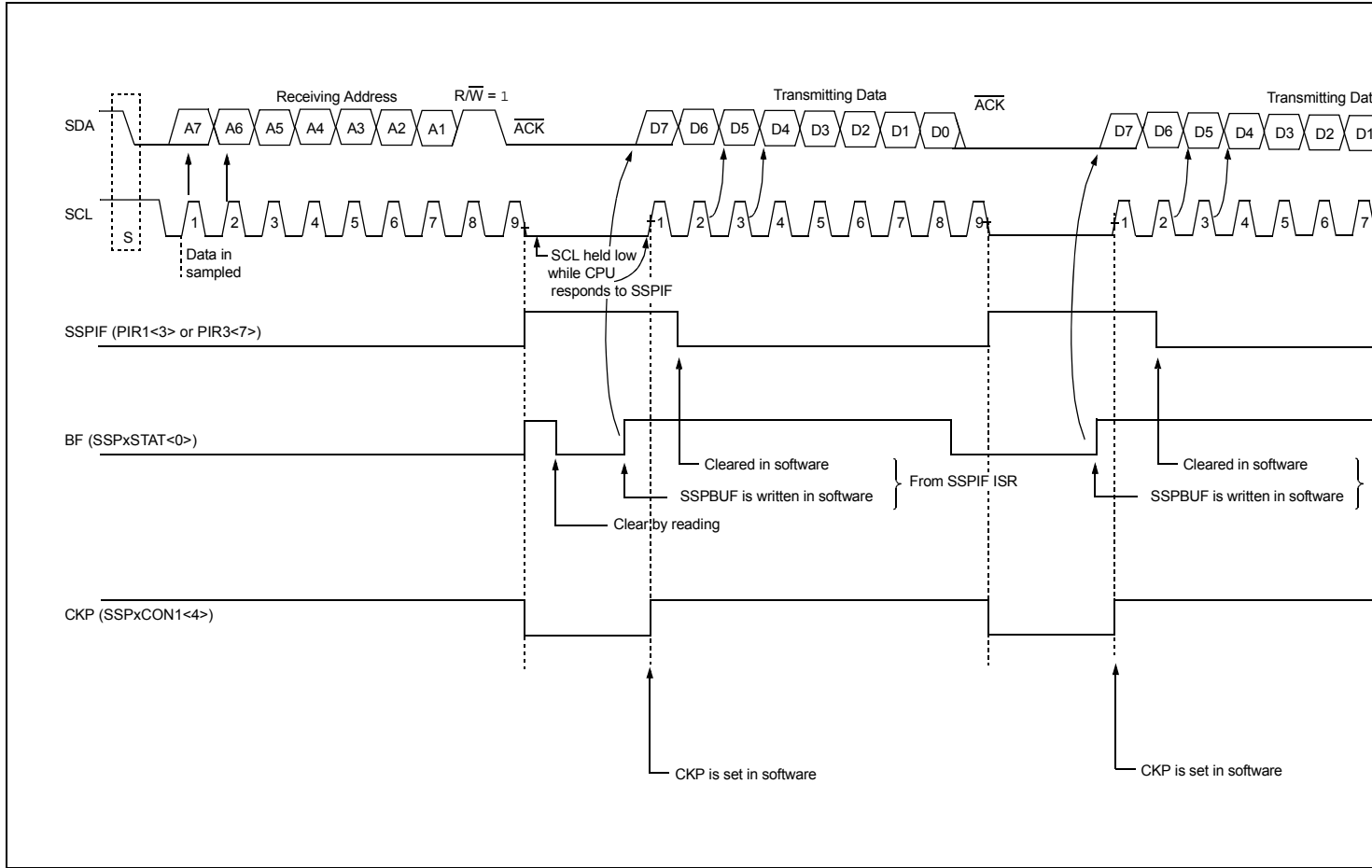
**FIGURE 18-8: I<sup>2</sup>C SLAVE MODE TIMING WITH SEN = 0 (RECEPTION, 7-BIT ADDRESSING)**



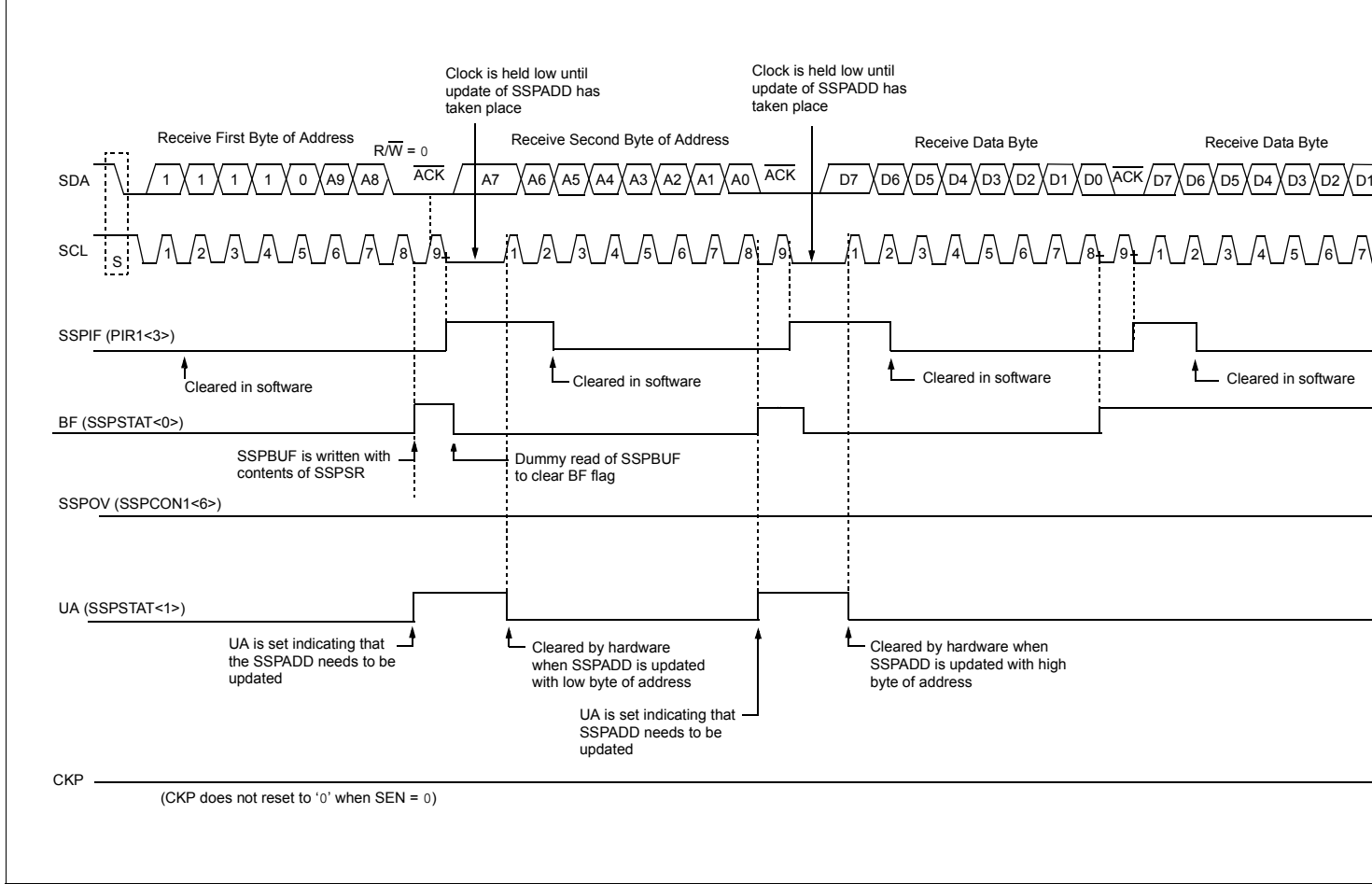
**FIGURE 18-9: I<sup>2</sup>C SLAVE MODE TIMING WITH SEN = 0 AND ADMSK<5:1> = 01011 (RECEPTION, 7-BIT ADDRESSING)**



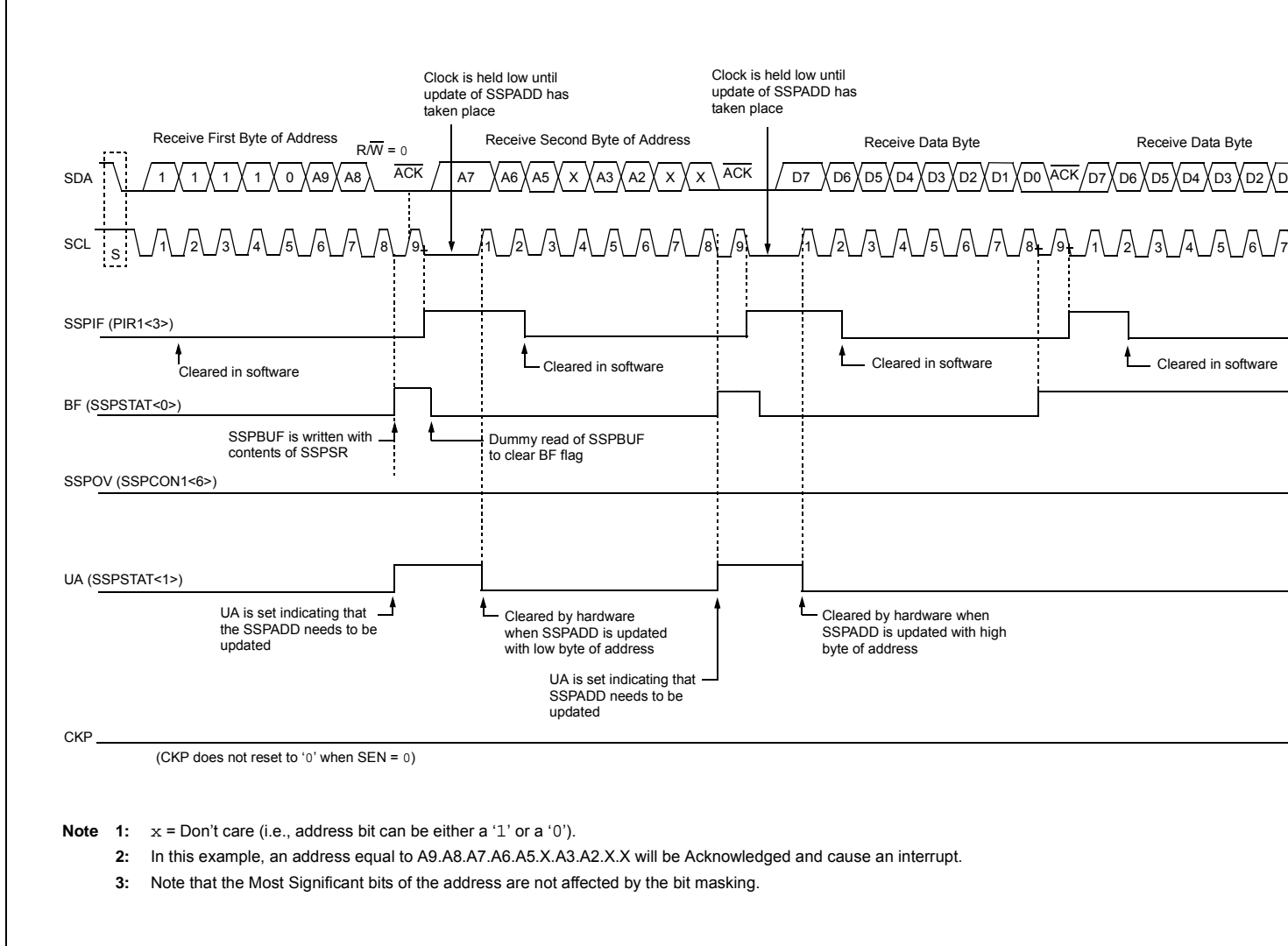
**FIGURE 18-10: I<sup>2</sup>C SLAVE MODE TIMING (TRANSMISSION, 7-BIT ADDRESSING)**



**FIGURE 18-11: I<sup>2</sup>C SLAVE MODE TIMING WITH SEN = 0 (RECEPTION, 10-BIT ADDRESSING)**

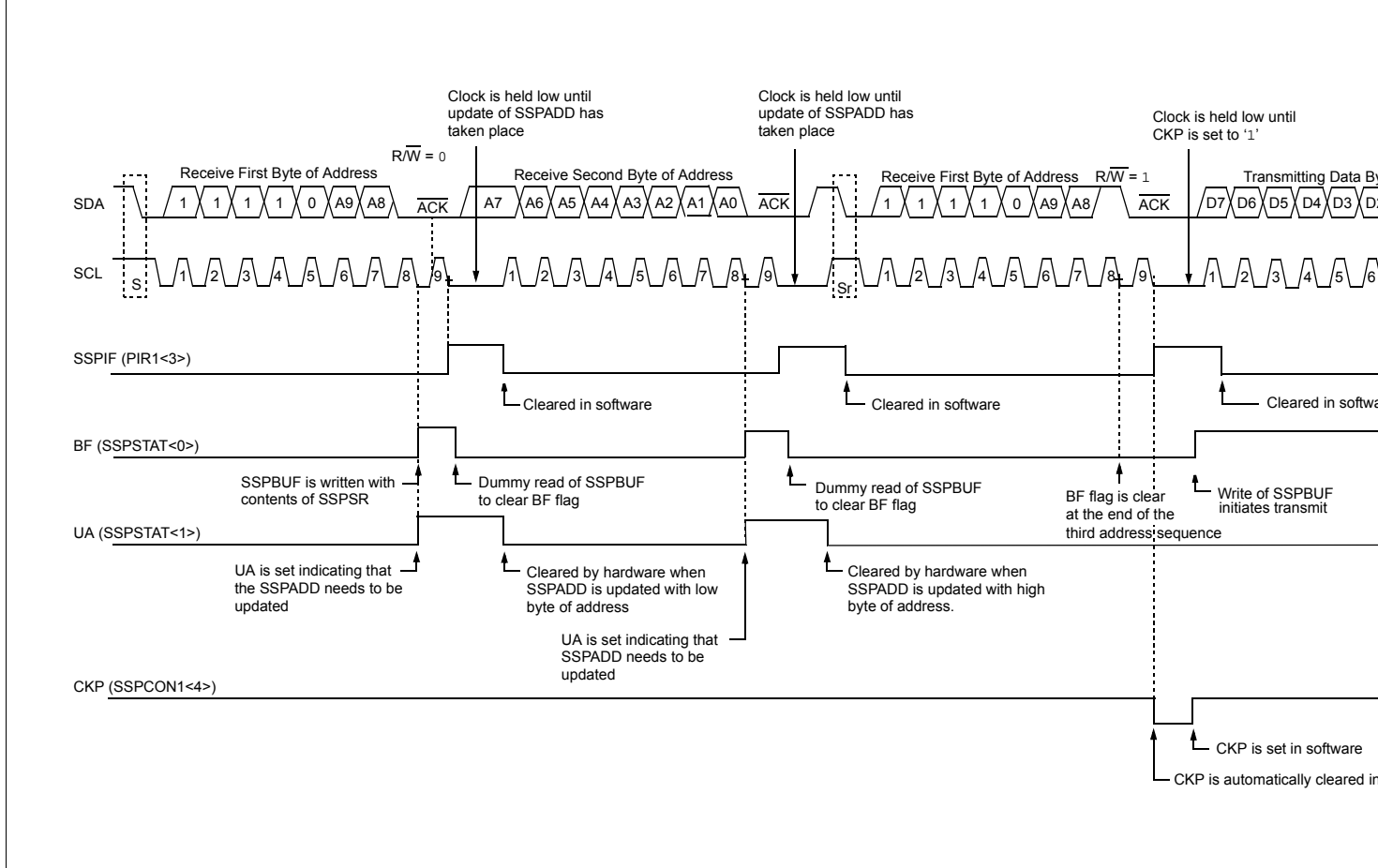


**FIGURE 18-12: I<sup>2</sup>C SLAVE MODE TIMING WITH SEN = 0 AND ADMSK<5:1> = 01001 (RECEPTION, 10-BIT ADDRESS)**





**FIGURE 18-13: I<sup>2</sup>C SLAVE MODE TIMING (TRANSMISSION, 10-BIT ADDRESSING)**



# PIC18F87J72

## 18.4.4 CLOCK STRETCHING

Both 7-Bit and 10-Bit Slave modes implement automatic clock stretching during a transmit sequence.

The SEN bit (SSPCON2<0>) allows clock stretching to be enabled during receives. Setting SEN will cause the SCL pin to be held low at the end of each data receive sequence.

### 18.4.4.1 Clock Stretching for 7-Bit Slave Receive Mode (SEN = 1)

In 7-Bit Slave Receive mode, on the falling edge of the ninth clock at the end of the ACK sequence, if the BF bit is set, the CKP bit in the SSPCON1 register is automatically cleared, forcing the SCL output to be held low. The CKP being cleared to '0' will assert the SCL line low. The CKP bit must be set in the user's ISR before reception is allowed to continue. By holding the SCL line low, the user has time to service the ISR and read the contents of the SSPBUF before the master device can initiate another receive sequence. This will prevent buffer overruns from occurring (see [Figure 18-15](#)).

**Note 1:** If the user reads the contents of the SSPBUF before the falling edge of the ninth clock, thus clearing the BF bit, the CKP bit will not be cleared and clock stretching will not occur.

**2:** The CKP bit can be set in software regardless of the state of the BF bit. The user should be careful to clear the BF bit in the ISR before the next receive sequence in order to prevent an overflow condition.

### 18.4.4.2 Clock Stretching for 10-Bit Slave Receive Mode (SEN = 1)

In 10-Bit Slave Receive mode, during the address sequence, clock stretching automatically takes place but CKP is not cleared. During this time, if the UA bit is set after the ninth clock, clock stretching is initiated. The UA bit is set after receiving the upper byte of the 10-bit address and following the receive of the second byte of the 10-bit address with the R/W bit cleared to '0'. The release of the clock line occurs upon updating SSPADD. Clock stretching will occur on each data receive sequence as described in 7-bit mode.

**Note:** If the user polls the UA bit and clears it by updating the SSPADD register before the falling edge of the ninth clock occurs and if the user hasn't cleared the BF bit by reading the SSPBUF register before that time, then the CKP bit will still NOT be asserted low. Clock stretching on the basis of the state of the BF bit only occurs during a data sequence, not an address sequence.

### 18.4.4.3 Clock Stretching for 7-Bit Slave Transmit Mode

The 7-Bit Slave Transmit mode implements clock stretching by clearing the CKP bit after the falling edge of the ninth clock if the BF bit is clear. This occurs regardless of the state of the SEN bit.

The user's ISR must set the CKP bit before transmission is allowed to continue. By holding the SCL line low, the user has time to service the ISR and load the contents of the SSPBUF before the master device can initiate another transmit sequence (see [Figure 18-10](#)).

**Note 1:** If the user loads the contents of SSPBUF, setting the BF bit before the falling edge of the ninth clock, the CKP bit will not be cleared and clock stretching will not occur.

**2:** The CKP bit can be set in software regardless of the state of the BF bit.

### 18.4.4.4 Clock Stretching for 10-Bit Slave Transmit Mode

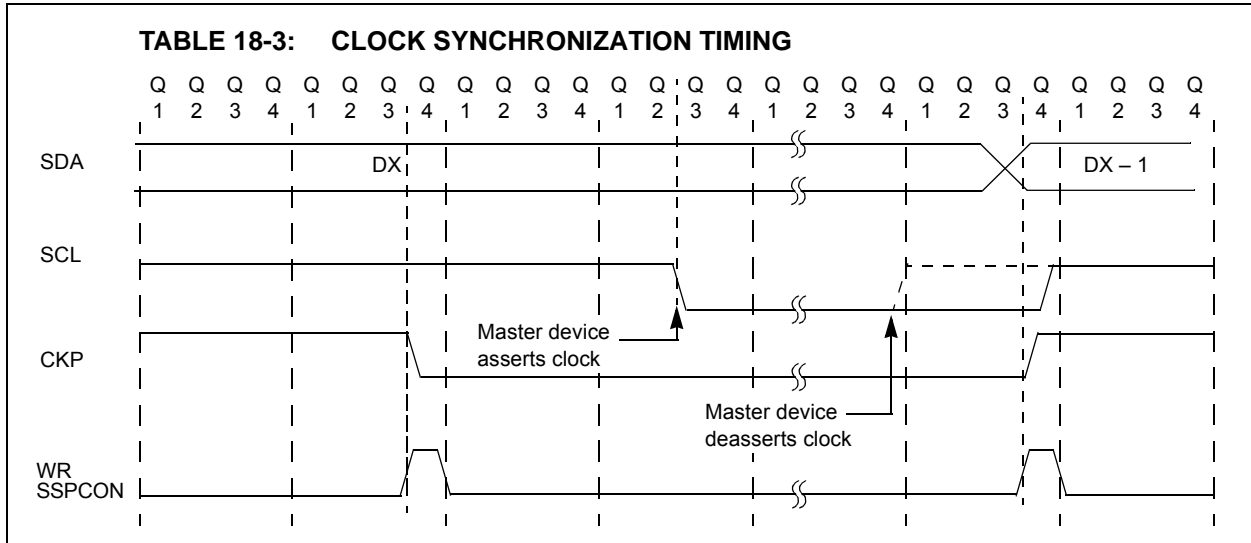
In 10-Bit Slave Transmit mode, clock stretching is controlled during the first two address sequences by the state of the UA bit, just as it is in 10-Bit Slave Receive mode. The first two addresses are followed by a third address sequence which contains the high-order bits of the 10-bit address and the R/W bit set to '1'. After the third address sequence is performed, the UA bit is not set, the module is now configured in Transmit mode and clock stretching is controlled by the BF flag as in 7-Bit Slave Transmit mode (see [Figure 18-13](#)).

## 18.4.4.5 Clock Synchronization and the CKP bit

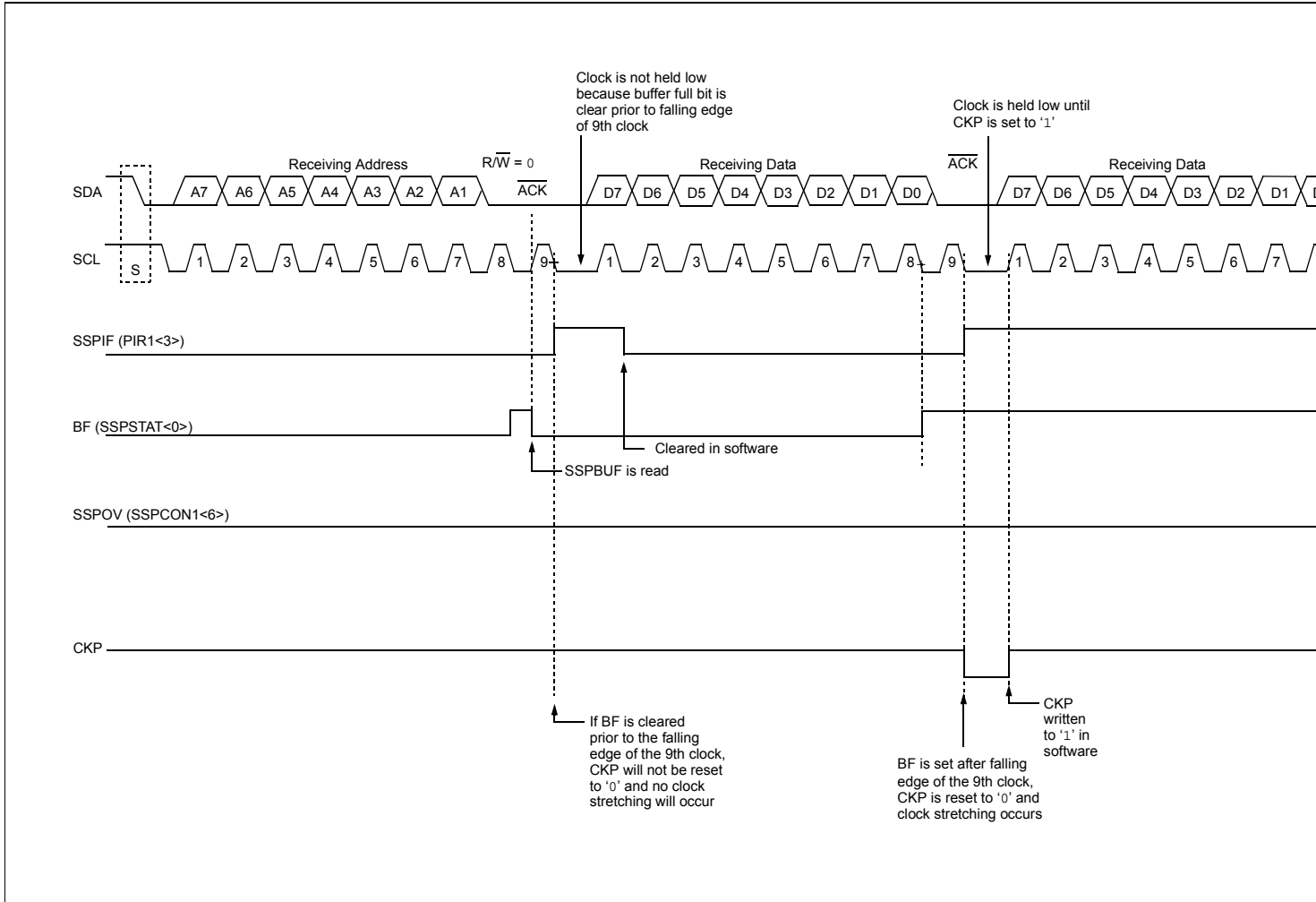
When the CKP bit is cleared, the SCL output is forced to '0'. However, clearing the CKP bit will not assert the SCL output low until the SCL output is already sampled low. Therefore, the CKP bit will not assert the SCL line until an external I<sup>2</sup>C master device has

already asserted the SCL line. The SCL output will remain low until the CKP bit is set and all other devices on the I<sup>2</sup>C bus have deasserted SCL. This ensures that a write to the CKP bit will not violate the minimum high time requirement for SCL (see [Figure 18-14](#)).

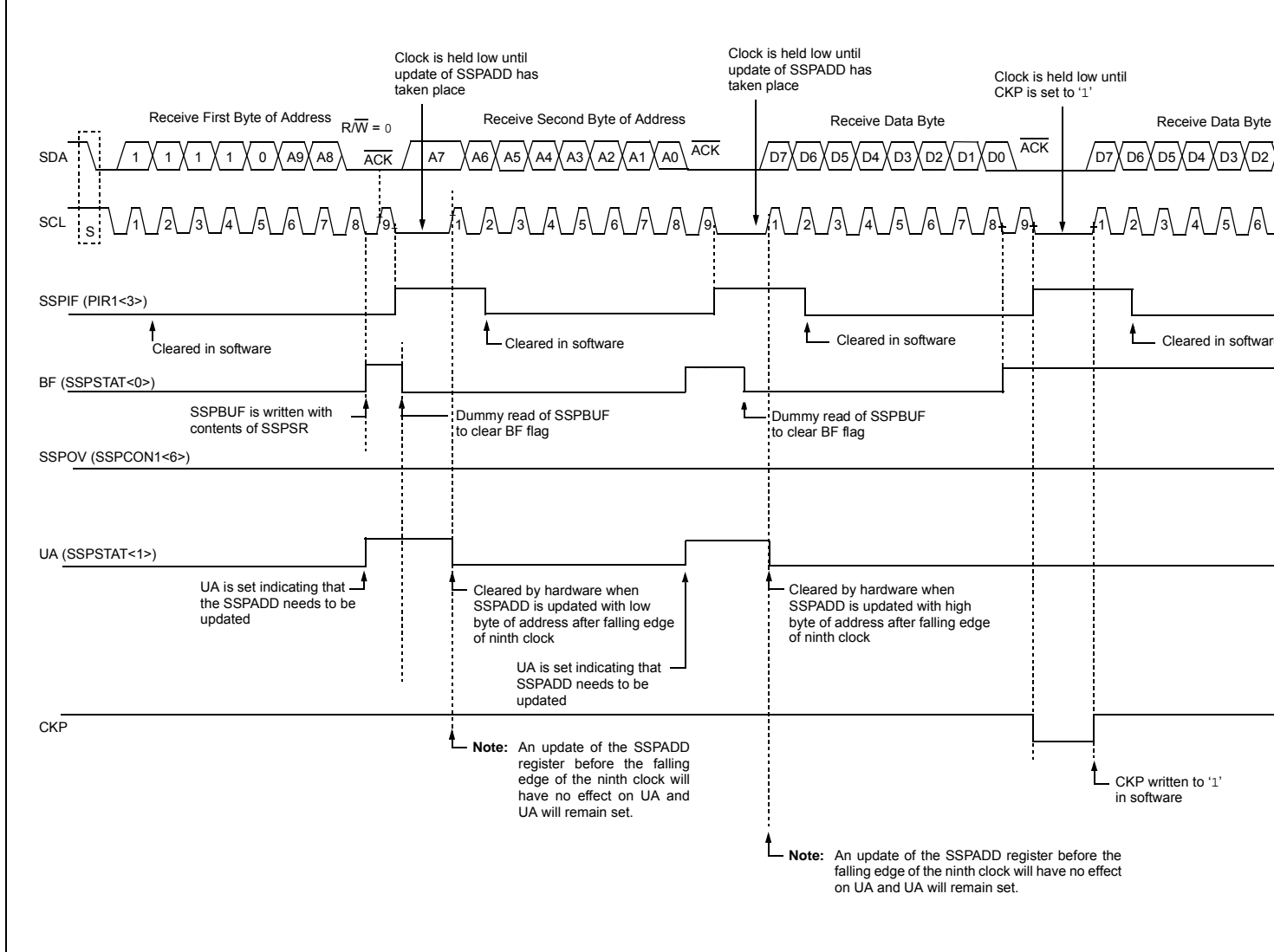
**FIGURE 18-14: CLOCK SYNCHRONIZATION TIMING**



**FIGURE 18-15: I<sup>2</sup>C SLAVE MODE TIMING WITH SEN = 1 (RECEPTION, 7-BIT ADDRESSING)**



**FIGURE 18-16: I<sup>2</sup>C SLAVE MODE TIMING WITH SEN = 1 (RECEPTION, 10-BIT ADDRESSING)**



# PIC18F87J72

## 18.4.5 GENERAL CALL ADDRESS SUPPORT

The addressing procedure for the I<sup>2</sup>C bus is such that the first byte after the Start condition usually determines which device will be the slave addressed by the master. The exception is the general call address which can address all devices. When this address is used, all devices should, in theory, respond with an Acknowledge.

The general call address is one of eight addresses reserved for specific purposes by the I<sup>2</sup>C protocol. It consists of all '0's with R/W = 0.

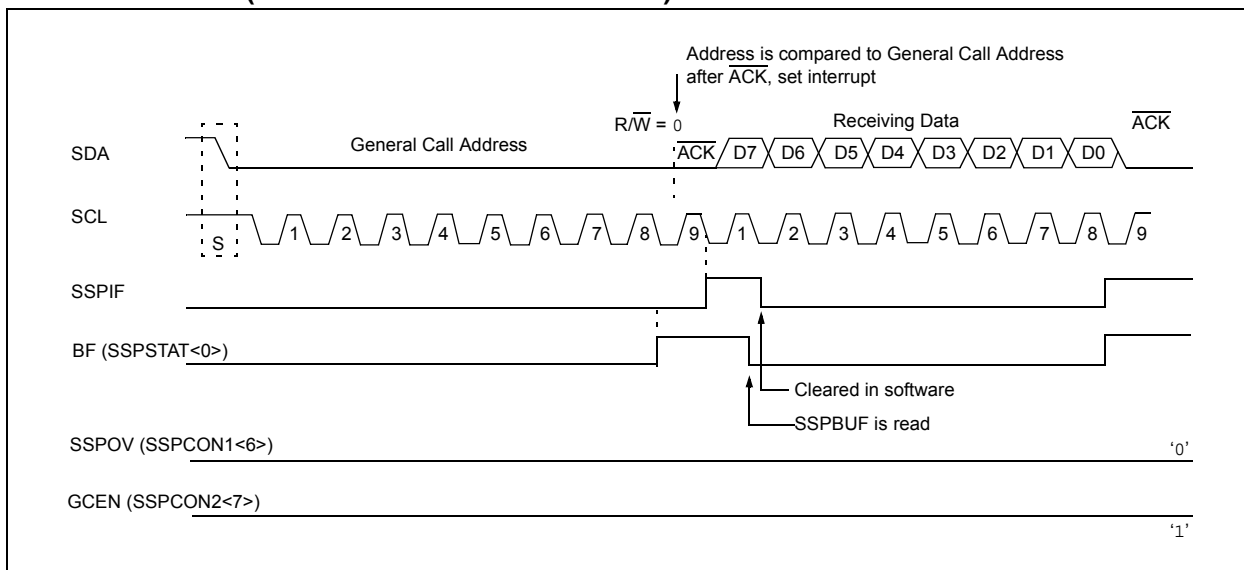
The general call address is recognized when the General Call Enable bit, GCEN, is enabled (SSPCON2<7> set). Following a Start bit detect, eight bits are shifted into the SSPSR and the address is compared against the SSPADD. It is also compared to the general call address and fixed in hardware.

If the general call address matches, the SSPSR is transferred to the SSPBUF, the BF flag bit is set (eighth bit), and on the falling edge of the ninth bit ( $\overline{\text{ACK}}$  bit), the SSPIF interrupt flag bit is set.

When the interrupt is serviced, the source for the interrupt can be checked by reading the contents of the SSPBUF. The value can be used to determine if the address was device-specific or a general call address.

In 10-bit mode, the SSPADD is required to be updated for the second half of the address to match and the UA bit is set (SSPSTAT<1>). If the general call address is sampled when the GCEN bit is set, while the slave is configured in 10-Bit Addressing mode, then the second half of the address is not necessary, the UA bit will not be set and the slave will begin receiving data after the Acknowledge (Figure 18-17).

**FIGURE 18-17: SLAVE MODE GENERAL CALL ADDRESS SEQUENCE (7 OR 10-BIT ADDRESSING MODE)**



## 18.4.6 MASTER MODE

Master mode is enabled by setting and clearing the appropriate SSPM bits in SSPCON1 and by setting the SSPEN bit. In Master mode, the SCL and SDA lines are manipulated by the MSSP hardware.

Master mode of operation is supported by interrupt generation on the detection of the Start and Stop conditions. The Stop (P) and Start (S) bits are cleared from a Reset or when the MSSP module is disabled. Control of the I<sup>2</sup>C bus may be taken when the P bit is set, or the bus is Idle, with both the S and P bits clear.

In Firmware Controlled Master mode, user code conducts all I<sup>2</sup>C bus operations based on Start and Stop bit conditions.

Once Master mode is enabled, the user has six options.

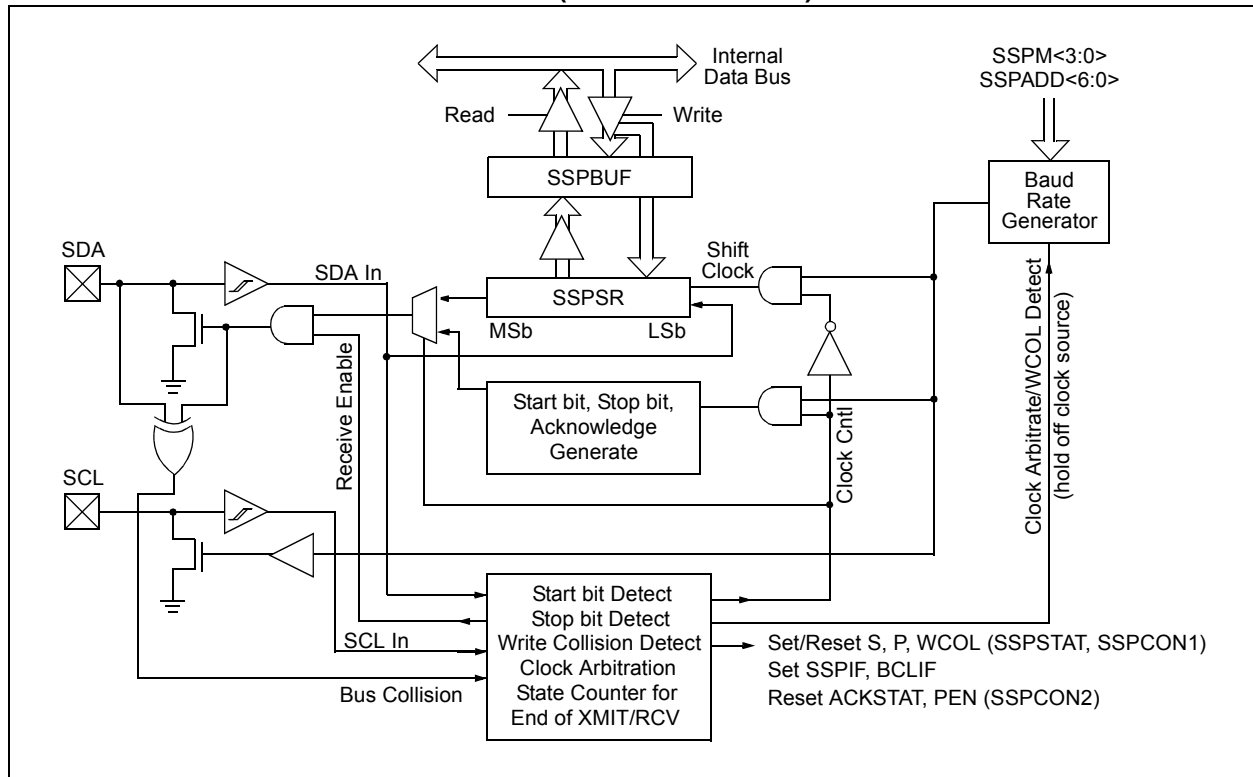
1. Assert a Start condition on SDA and SCL.
2. Assert a Repeated Start condition on SDA and SCL.
3. Write to the SSPBUF register initiating transmission of data/address.
4. Configure the I<sup>2</sup>C port to receive data.
5. Generate an Acknowledge condition at the end of a received byte of data.
6. Generate a Stop condition on SDA and SCL.

**Note:** The MSSP module, when configured in I<sup>2</sup>C Master mode, does not allow queuing of events. For instance, the user is not allowed to initiate a Start condition and immediately write the SSPBUF register to initiate transmission before the Start condition is complete. In this case, the SSPBUF will not be written to and the WCOL bit will be set, indicating that a write to the SSPBUF did not occur.

The following events will cause the MSSP Interrupt Flag bit, SSPIF, to be set (and MSSP interrupt, if enabled):

- Start condition
- Stop condition
- Data transfer byte transmitted/received
- Acknowledge transmit
- Repeated Start

**FIGURE 18-18: MSSP BLOCK DIAGRAM (I<sup>2</sup>C MASTER MODE)**



# PIC18F87J72

---

## 18.4.6.1 I<sup>2</sup>C Master Mode Operation

The master device generates all of the serial clock pulses and the Start and Stop conditions. A transfer is ended with a Stop condition or with a Repeated Start condition. Since the Repeated Start condition is also the beginning of the next serial transfer, the I<sup>2</sup>C bus will not be released.

In Master Transmitter mode, serial data is output through SDA, while SCL outputs the serial clock. The first byte transmitted contains the slave address of the receiving device (7 bits) and the Read/Write (R/W) bit. In this case, the R/W bit will be logic '0'. Serial data is transmitted, eight bits at a time. After each byte is transmitted, an Acknowledge bit is received. Start and Stop conditions are output to indicate the beginning and the end of a serial transfer.

In Master Receive mode, the first byte transmitted contains the slave address of the transmitting device (7 bits) and the R/W bit. In this case, the R/W bit will be logic '1'. Thus, the first byte transmitted is a 7-bit slave address followed by a '1' to indicate the receive bit. Serial data is received via SDA, while SCL outputs the serial clock. Serial data is received eight bits at a time. After each byte is received, an Acknowledge bit is transmitted. Start and Stop conditions indicate the beginning and end of transmission.

The Baud Rate Generator, used for the SPI mode operation, is used to set the SCL clock frequency for either 100 kHz, 400 kHz or 1 MHz I<sup>2</sup>C operation. See [Section 18.4.7 "Baud Rate"](#) for more detail.

A typical transmit sequence would go as follows:

1. The user generates a Start condition by setting the Start Enable bit, SEN (SSPCON2<0>).
2. SSPIF is set. The MSSP module will wait the required start time before any other operation takes place.
3. The user loads the SSPBUF with the slave address to transmit.
4. Address is shifted out the SDA pin until all eight bits are transmitted.
5. The MSSP module shifts in the ACK bit from the slave device and writes its value into the SSPCON2 register (SSPCON2<6>).
6. The MSSP module generates an interrupt at the end of the ninth clock cycle by setting the SSPIF bit.
7. The user loads the SSPBUF with eight bits of data.
8. Data is shifted out the SDA pin until all eight bits are transmitted.
9. The MSSP module shifts in the ACK bit from the slave device and writes its value into the SSPCON2 register (SSPCON2<6>).
10. The MSSP module generates an interrupt at the end of the ninth clock cycle by setting the SSPIF bit.
11. The user generates a Stop condition by setting the Stop Enable bit, PEN (SSPCON2<2>).
12. Interrupt is generated once the Stop condition is complete.



## 18.4.7 BAUD RATE

In I<sup>2</sup>C Master mode, the Baud Rate Generator (BRG) reload value is placed in the lower seven bits of the SSPADD register (Figure 18-19). When a write occurs to SSPBUF, the Baud Rate Generator will automatically begin counting. The BRG counts down to 0 and stops until another reload has taken place. The BRG count is decremented twice per instruction cycle (T<sub>CY</sub>) on the Q2 and Q4 clocks. In I<sup>2</sup>C Master mode, the BRG is reloaded automatically.

Once the given operation is complete (i.e., transmission of the last data bit is followed by ACK), the internal clock will automatically stop counting and the SCL pin will remain in its last state.

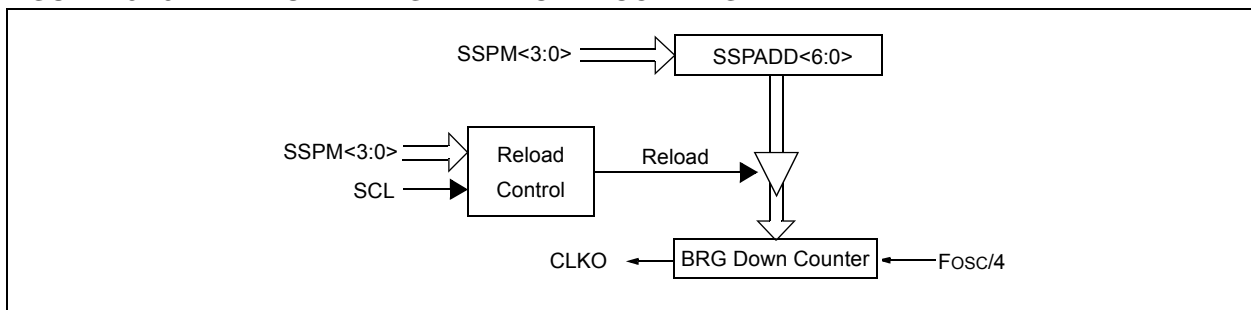
Table 18-4 demonstrates clock rates based on instruction cycles and the BRG value loaded into SSPADD.

**Note:** A BRG value of 00h is not supported.

### 18.4.7.1 Baud Rate Generation in Power-Managed Modes

When the device is operating in one of the power-managed modes, the clock source to the BRG may change frequency or even stop, depending on the mode and clock source selected. Switching to a Run or Idle mode from either the secondary clock or internal oscillator is likely to change the clock rate to the BRG. In Sleep mode, the BRG will not be clocked at all.

**FIGURE 18-19: BAUD RATE GENERATOR BLOCK DIAGRAM**



**TABLE 18-4: I<sup>2</sup>C CLOCK RATE w/BRG**

F <sub>cy</sub>	F <sub>cy</sub> * 2	BRG Value	F <sub>scl</sub> (2 Rollovers of BRG)
16 MHz	32 MHz	03h	1 MHz <sup>(1)</sup>
10 MHz	20 MHz	18h	400 kHz <sup>(2)</sup>
10 MHz	20 MHz	1Fh	312.5 kHz
10 MHz	20 MHz	63h	100 kHz
4 MHz	8 MHz	09h	400 kHz <sup>(2)</sup>
4 MHz	8 MHz	0Ch	308 kHz
4 MHz	8 MHz	27h	100 kHz
1 MHz	2 MHz	02h	333 kHz <sup>(2)</sup>
1 MHz	2 MHz	09h	100 kHz

**Note 1:** F<sub>osc</sub> must be at least 16 MHz for I<sup>2</sup>C bus operation at this speed.

**Note 2:** The I<sup>2</sup>C interface does not conform to the 400 kHz I<sup>2</sup>C specification (which applies to rates greater than 100 kHz) in all details, but may be used with care where higher rates are required by the application.

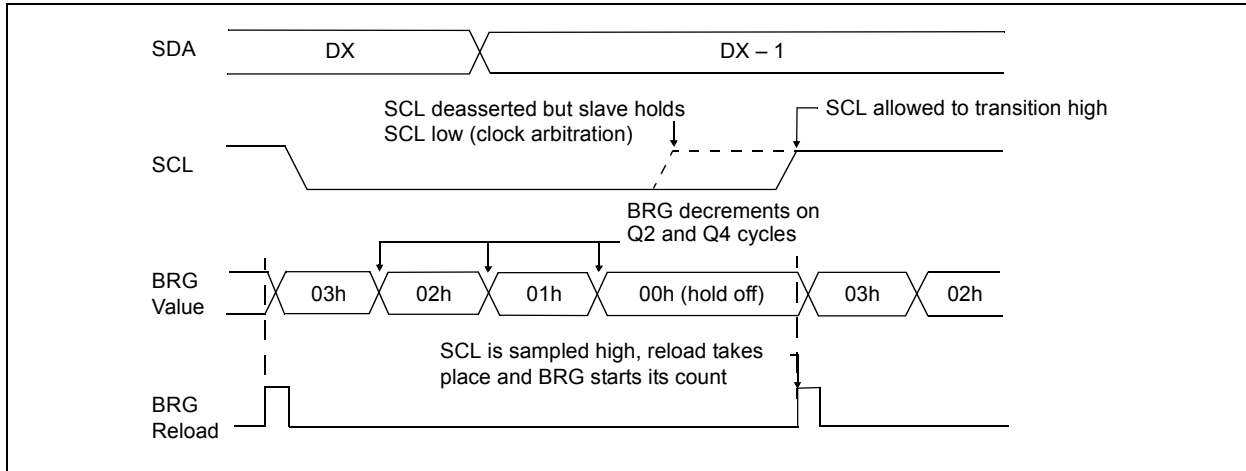
# PIC18F87J72

## 18.4.7.2 Clock Arbitration

Clock arbitration occurs when the master, during any receive, transmit or Repeated Start/Stop condition, deasserts the SCL pin (SCL allowed to float high). When the SCL pin is allowed to float high, the Baud Rate Generator (BRG) is suspended from counting until the SCL pin is actually sampled high. When the

SCL pin is sampled high, the Baud Rate Generator is reloaded with the contents of SSPADD<6:0> and begins counting. This ensures that the SCL high time will always be at least one BRG rollover count in the event that the clock is held low by an external device (Figure 18-20).

**FIGURE 18-20: BAUD RATE GENERATOR TIMING WITH CLOCK ARBITRATION**



## 18.4.8 I<sup>2</sup>C MASTER MODE START CONDITION TIMING

To initiate a Start condition, the user sets the Start Enable bit, SEN (SSPCON2<0>). If the SDA and SCL pins are sampled high, the Baud Rate Generator is reloaded with the contents of SSPADD<6:0> and starts its count. If SCL and SDA are both sampled high when the Baud Rate Generator times out (TBRG), the SDA pin is driven low. The action of the SDA being driven low while SCL is high is the Start condition and causes the S bit (SSPSTAT<3>) to be set. Following this, the Baud Rate Generator is reloaded with the contents of SSPADD<6:0> and resumes its count. When the Baud Rate Generator times out (TBRG), the SEN bit (SSPCON2<0>) will automatically be cleared by hardware. The Baud Rate Generator is suspended, leaving the SDA line held low and the Start condition is complete.

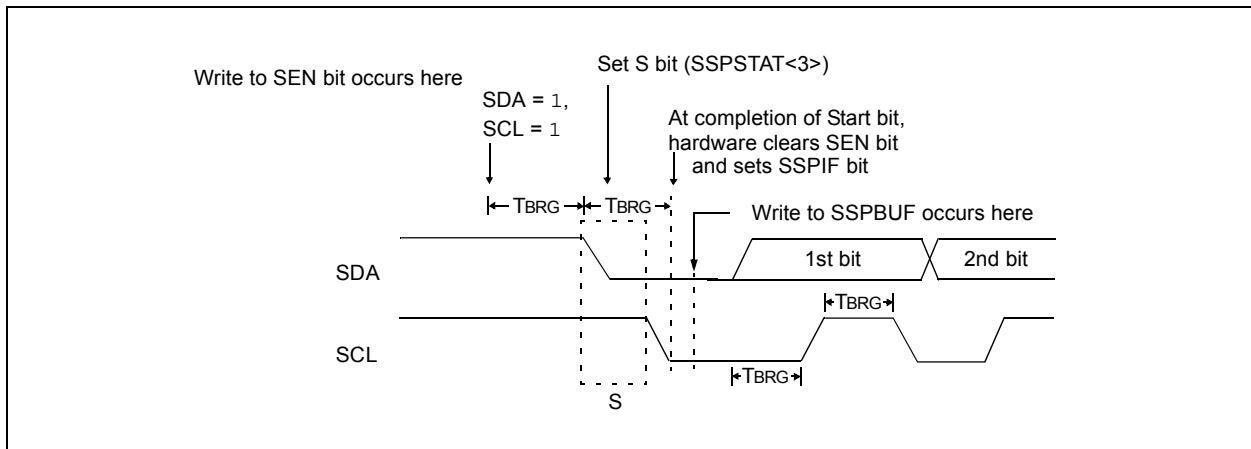
**Note:** If, at the beginning of the Start condition, the SDA and SCL pins are already sampled low, or if during the Start condition, the SCL line is sampled low before the SDA line is driven low, a bus collision occurs. The Bus Collision Interrupt Flag, BCLIF, is set, the Start condition is aborted and the I<sup>2</sup>C module is reset into its Idle state.

### 18.4.8.1 WCOL Status Flag

If the user writes the SSPBUF when a Start sequence is in progress, the WCOL is set and the contents of the buffer are unchanged (the write does not occur).

**Note:** Because queuing of events is not allowed, writing to the lower five bits of SSPCON2 is disabled until the Start condition is complete.

**FIGURE 18-21: FIRST START BIT TIMING**



# PIC18F87J72

## 18.4.9 I<sup>2</sup>C MASTER MODE REPEATED START CONDITION TIMING

A Repeated Start condition occurs when the RSEN bit (SSPCON2<1>) is programmed high and the I<sup>2</sup>C logic module is in the Idle state. When the RSEN bit is set, the SCL pin is asserted low. When the SCL pin is sampled low, the Baud Rate Generator is loaded with the contents of SSPADD<6:0> and begins counting. The SDA pin is released (brought high) for one Baud Rate Generator count (TBRG). When the Baud Rate Generator times out, if SDA is sampled high, the SCL pin will be deasserted (brought high). When SCL is sampled high, the Baud Rate Generator is reloaded with the contents of SSPADD<6:0> and begins counting. SDA and SCL must be sampled high for one TBRG. This action is then followed by assertion of the SDA pin (SDA = 0) for one TBRG while SCL is high. Following this, the RSEN bit (SSPCON2<1>) will be automatically cleared and the Baud Rate Generator will not be reloaded, leaving the SDA pin held low. As soon as a Start condition is detected on the SDA and SCL pins, the S bit (SSPSTAT<3>) will be set. The SSPIF bit will not be set until the Baud Rate Generator has timed out.

**Note 1:** If RSEN is programmed while any other event is in progress, it will not take effect.

**2:** A bus collision during the Repeated Start condition occurs if:

- SDA is sampled low when SCL goes from low-to-high.
- SCL goes low before SDA is asserted low. This may indicate that another master is attempting to transmit a data '1'.

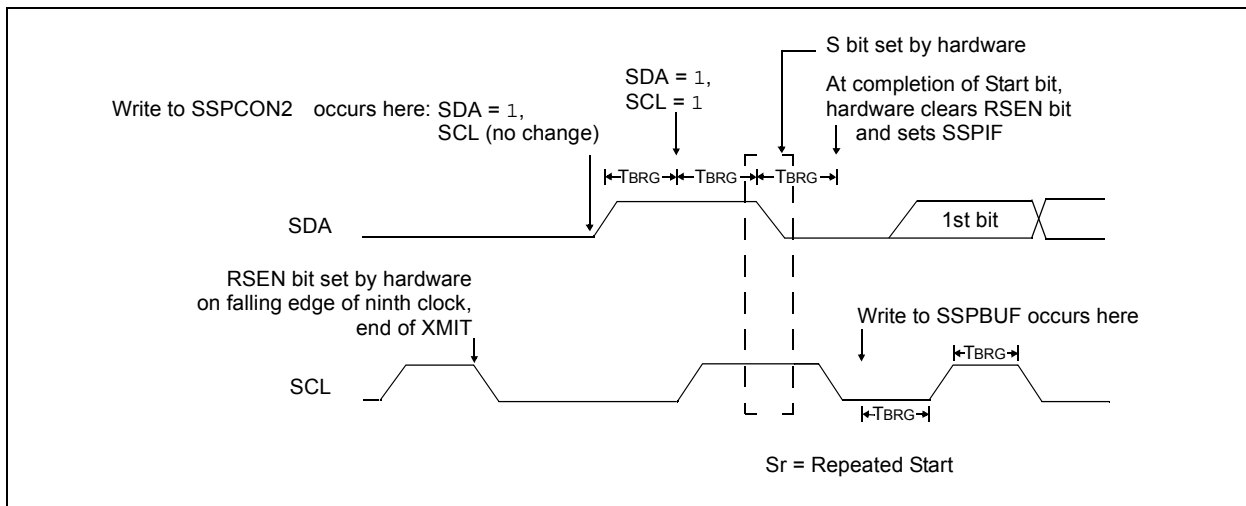
Immediately following the SSPIF bit getting set, the user may write the SSPBUF with the 7-bit address in 7-bit mode or the default first address in 10-bit mode. After the first eight bits are transmitted and an ACK is received, the user may then transmit an additional eight bits of address (10-bit mode) or eight bits of data (7-bit mode).

### 18.4.9.1 WCOL Status Flag

If the user writes the SSPBUF when a Repeated Start sequence is in progress, the WCOL is set and the contents of the buffer are unchanged (the write does not occur).

**Note:** Because queuing of events is not allowed, writing of the lower five bits of SSPCON2 is disabled until the Repeated Start condition is complete.

**FIGURE 18-22: REPEATED START CONDITION WAVEFORM**



## 18.4.10 I<sup>2</sup>C MASTER MODE TRANSMISSION

Transmission of a data byte, a 7-bit address or the other half of a 10-bit address, is accomplished by simply writing a value to the SSPBUF register. This action will set the Buffer Full bit, BF, and allow the Baud Rate Generator to begin counting and start the next transmission. Each bit of address/data will be shifted out onto the SDA pin after the falling edge of SCL is asserted (see data hold time specification Parameter 106). SCL is held low for one Baud Rate Generator rollover count (TBRG). Data should be valid before SCL is released high (see data setup time specification Parameter 107). When the SCL pin is released high, it is held that way for TBRG. The data on the SDA pin must remain stable for that duration and some hold time after the next falling edge of SCL. After the eighth bit is shifted out (the falling edge of the eighth clock), the BF flag is cleared and the master releases SDA. This allows the slave device being addressed to respond with an  $\overline{\text{ACK}}$  bit during the ninth bit time if an address match occurred, or if data was received properly. The status of  $\overline{\text{ACK}}$  is written into the ACKDT bit on the falling edge of the ninth clock. If the master receives an Acknowledge, the Acknowledge Status bit, ACKSTAT, is cleared; if not, the bit is set. After the ninth clock, the SSPIF bit is set and the master clock (Baud Rate Generator) is suspended until the next data byte is loaded into the SSPBUF, leaving SCL low and SDA unchanged (Figure 18-23).

After the write to the SSPBUF, each bit of the address will be shifted out on the falling edge of SCL until all seven address bits and the R/W bit are completed. On the falling edge of the eighth clock, the master will deassert the SDA pin, allowing the slave to respond with an Acknowledge. On the falling edge of the ninth clock, the master will sample the SDA pin to see if the address was recognized by a slave. The status of the  $\overline{\text{ACK}}$  bit is loaded into the ACKSTAT Status bit (SSPCON2<6>). Following the falling edge of the ninth clock transmission of the address, the SSPIF is set, the BF flag is cleared and the Baud Rate Generator is turned off until another write to the SSPBUF takes place, holding SCL low and allowing SDA to float.

### 18.4.10.1 BF Status Flag

In Transmit mode, the BF bit (SSPSTAT<0>) is set when the CPU writes to SSPBUF and is cleared when all eight bits are shifted out.

### 18.4.10.2 WCOL Status Flag

If the user writes to the SSPBUF when a transmit is already in progress (i.e., SSPSR is still shifting out a data byte), the WCOL is set and the contents of the buffer are unchanged (the write does not occur) after 2 T<sub>cy</sub> after the SSPBUF write. If SSPBUF is rewritten within 2 T<sub>cy</sub>, the WCOL bit is set and SSPBUF is updated. This may result in a corrupted transfer.

The user should verify that the WCOL is clear after each write to SSPBUF to ensure the transfer is correct. In all cases, WCOL must be cleared in software.

### 18.4.10.3 ACKSTAT Status Flag

In Transmit mode, the ACKSTAT bit (SSPCON2<6>) is cleared when the slave has sent an Acknowledge ( $\overline{\text{ACK}} = 0$ ) and is set when the slave does not Acknowledge ( $\overline{\text{ACK}} = 1$ ). A slave sends an Acknowledge when it has recognized its address (including a general call), or when the slave has properly received its data.

## 18.4.11 I<sup>2</sup>C MASTER MODE RECEPTION

Master mode reception is enabled by programming the Receive Enable bit, RCEN (SSPCON2<3>).

**Note:** The MSSP module must be in an Idle state before the RCEN bit is set or the RCEN bit will be disregarded.

The Baud Rate Generator begins counting and on each rollover, the state of the SCL pin changes (high-to-low/low-to-high) and data is shifted into the SSPSR. After the falling edge of the eighth clock, the receive enable flag is automatically cleared, the contents of the SSPSR are loaded into the SSPBUF, the BF flag bit is set, the SSPIF flag bit is set and the Baud Rate Generator is suspended from counting, holding SCL low. The MSSP is now in Idle state awaiting the next command. When the buffer is read by the CPU, the BF flag bit is automatically cleared. The user can then send an Acknowledge bit at the end of reception by setting the Acknowledge Sequence Enable bit, ACKEN (SSPCON2<4>).

### 18.4.11.1 BF Status Flag

In receive operation, the BF bit is set when an address or data byte is loaded into SSPBUF from SSPSR. It is cleared when the SSPBUF register is read.

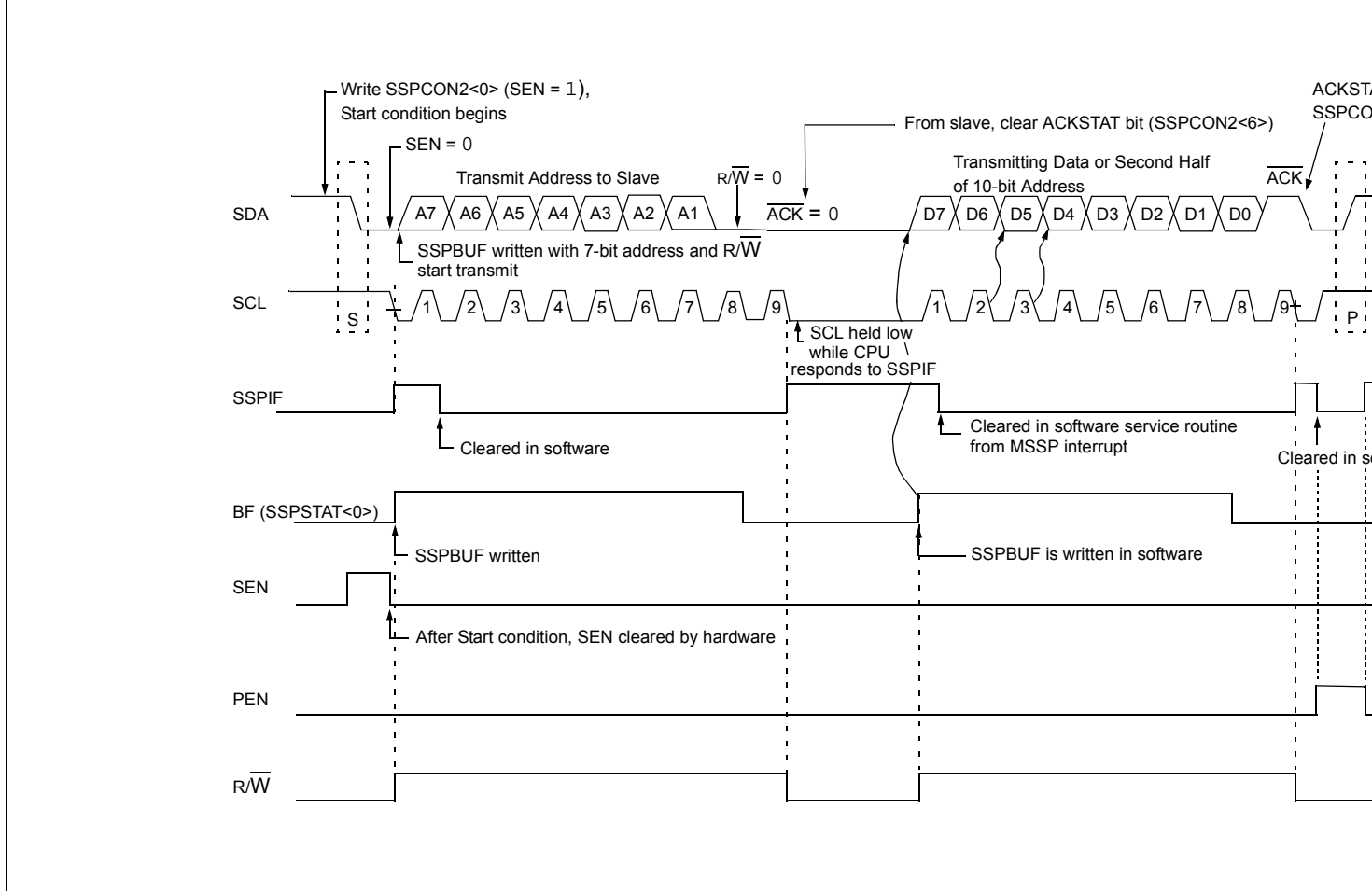
### 18.4.11.2 SSPOV Status Flag

In receive operation, the SSPOV bit is set when eight bits are received into the SSPSR and the BF flag bit is already set from a previous reception.

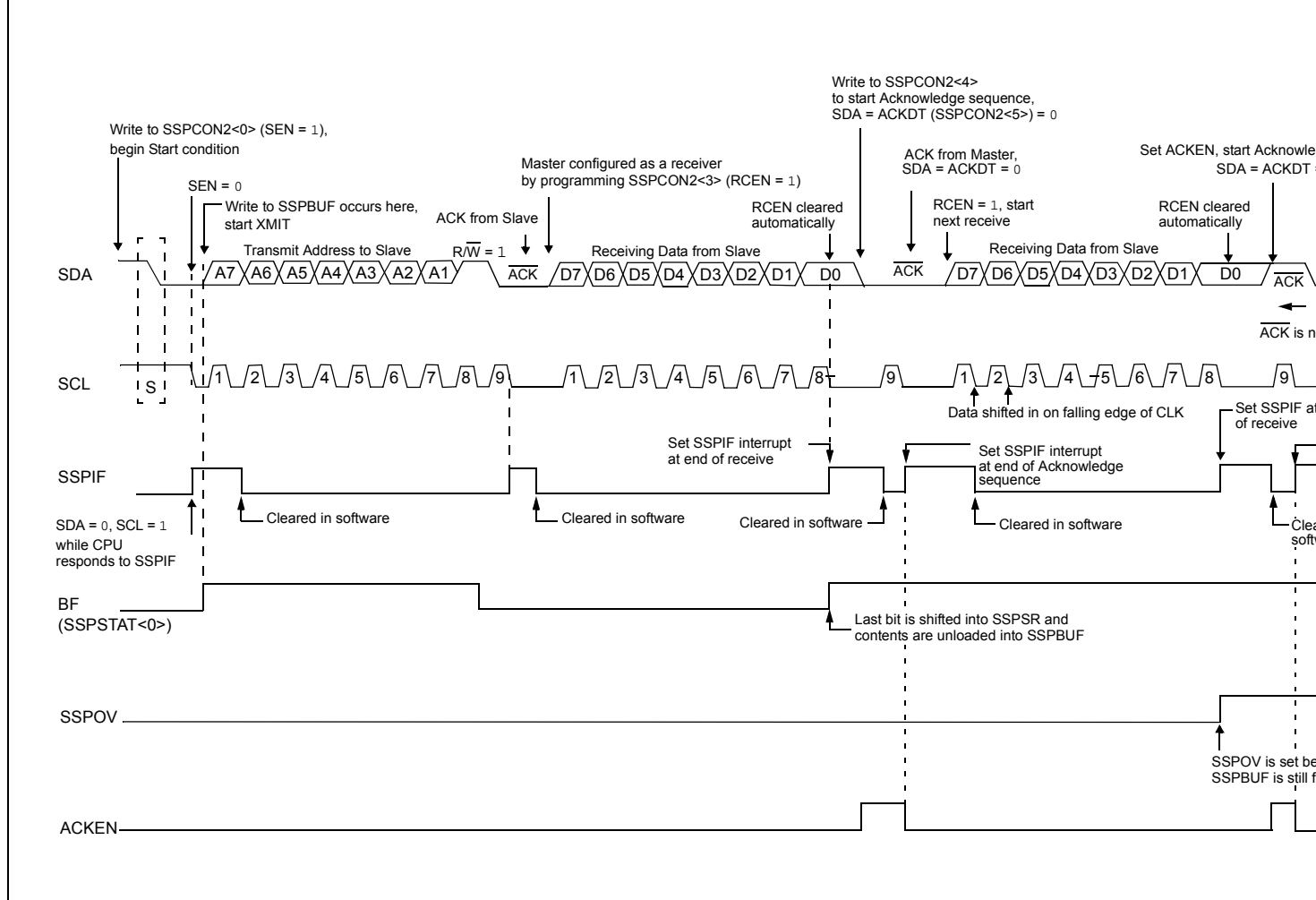
### 18.4.11.3 WCOL Status Flag

If the user writes the SSPBUF when a receive is already in progress (i.e., SSPSR is still shifting in a data byte), the WCOL bit is set and the contents of the buffer are unchanged (the write does not occur).

**FIGURE 18-23: I<sup>2</sup>C MASTER MODE WAVEFORM (TRANSMISSION, 7 OR 10-BIT ADDRESSING)**



**FIGURE 18-24: I<sup>2</sup>C MASTER MODE WAVEFORM (RECEPTION, 7-BIT ADDRESSING)**



# PIC18F87J72

## 18.4.12 ACKNOWLEDGE SEQUENCE TIMING

An Acknowledge sequence is enabled by setting the Acknowledge Sequence Enable bit, ACKEN (SSPCON2<4>). When this bit is set, the SCL pin is pulled low and the contents of the Acknowledge data bit are presented on the SDA pin. If the user wishes to generate an Acknowledge, then the ACKDT bit should be cleared. If not, the user should set the ACKDT bit before starting an Acknowledge sequence. The Baud Rate Generator then counts for one rollover period (TBRG) and the SCL pin is deasserted (pulled high). When the SCL pin is sampled high (clock arbitration), the Baud Rate Generator counts for TBRG. The SCL pin is then pulled low. Following this, the ACKEN bit is automatically cleared, the Baud Rate Generator is turned off and the MSSP module then goes into Idle mode (Figure 18-25).

### 18.4.12.1 WCOL Status Flag

If the user writes the SSPBUF when an Acknowledge sequence is in progress, then WCOL is set and the contents of the buffer are unchanged (the write does not occur).

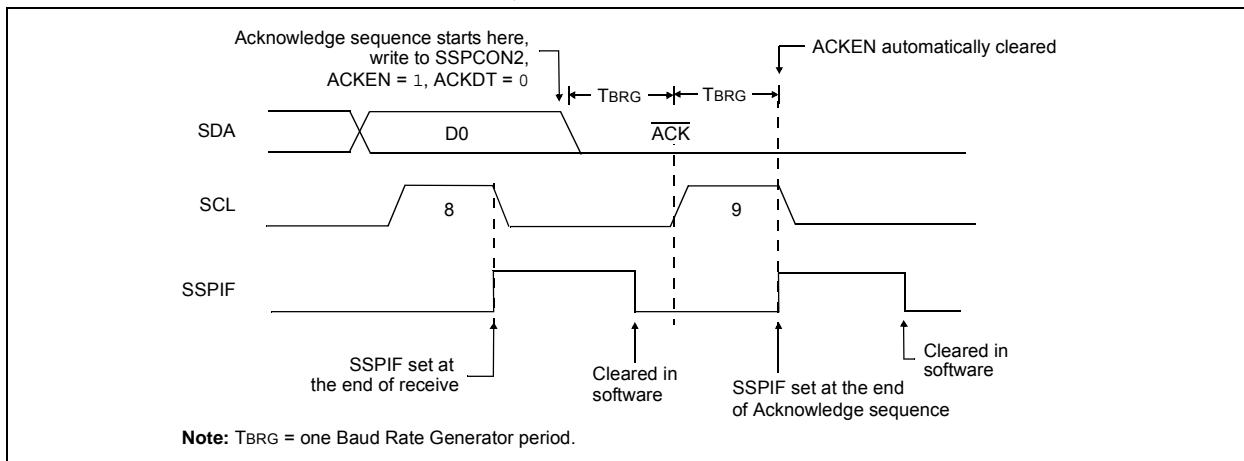
## 18.4.13 STOP CONDITION TIMING

A Stop bit is asserted on the SDA pin at the end of a receive/transmit by setting the Stop Sequence Enable bit, PEN (SSPCON2<2>). At the end of a receive/transmit, the SCL line is held low after the falling edge of the ninth clock. When the PEN bit is set, the master will assert the SDA line low. When the SDA line is sampled low, the Baud Rate Generator is reloaded and counts down to 0. When the Baud Rate Generator times out, the SCL pin will be brought high and one TBRG (Baud Rate Generator rollover count) later, the SDA pin will be deasserted. When the SDA pin is sampled high while SCL is high, the P bit (SSPSTAT<4>) is set. A TBRG later, the PEN bit is cleared and the SSPIF bit is set (Figure 18-26).

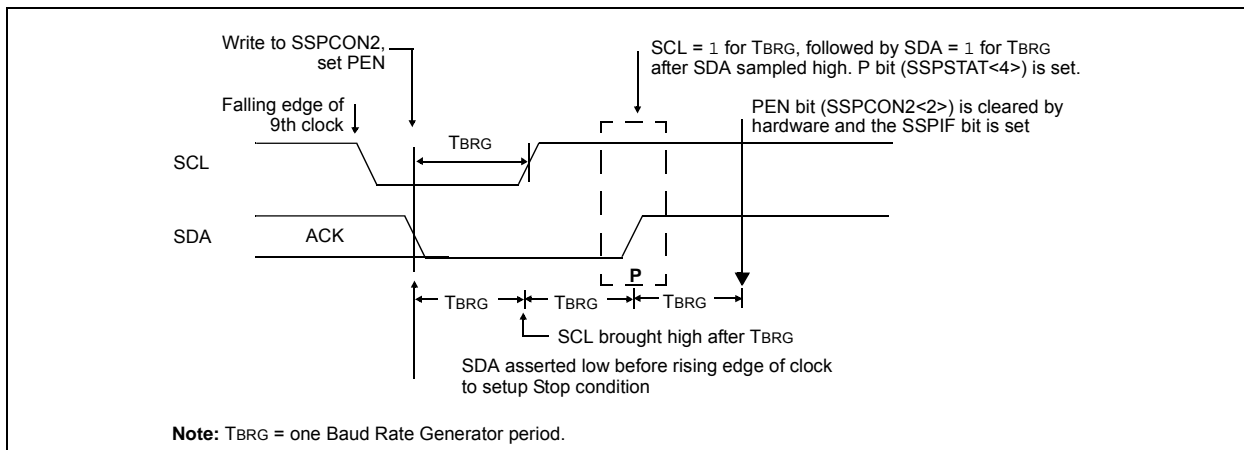
### 18.4.13.1 WCOL Status Flag

If the user writes the SSPBUF when a Stop sequence is in progress, then the WCOL bit is set and the contents of the buffer are unchanged (the write does not occur).

**FIGURE 18-25: ACKNOWLEDGE SEQUENCE WAVEFORM**



**FIGURE 18-26: STOP CONDITION RECEIVE OR TRANSMIT MODE**





## 18.4.14 SLEEP OPERATION

While in Sleep mode, the I<sup>2</sup>C module can receive addresses or data and when an address match or complete byte transfer occurs, wake the processor from Sleep (if the MSSP interrupt is enabled).

## 18.4.15 EFFECTS OF A RESET

A Reset disables the MSSP module and terminates the current transfer.

## 18.4.16 MULTI-MASTER MODE

In Multi-Master mode, the interrupt generation on the detection of the Start and Stop conditions allows the determination of when the bus is free. The Stop (P) and Start (S) bits are cleared from a Reset or when the MSSP module is disabled. Control of the I<sup>2</sup>C bus may be taken when the P bit (SSPSTAT<4>) is set, or the bus is Idle, with both the S and P bits clear. When the bus is busy, enabling the MSSP interrupt will generate the interrupt when the Stop condition occurs.

In multi-master operation, the SDA line must be monitored for arbitration to see if the signal level is the expected output level. This check is performed in hardware with the result placed in the BCLIF bit.

The states where arbitration can be lost are:

- Address Transfer
- Data Transfer
- A Start Condition
- A Repeated Start Condition
- An Acknowledge Condition

## 18.4.17 MULTI-MASTER COMMUNICATION, BUS COLLISION AND BUS ARBITRATION

Multi-Master mode support is achieved by bus arbitration. When the master outputs address/data bits onto the SDA pin, arbitration takes place when the master outputs a '1' on SDA by letting SDA float high, and another master asserts a '0'. When the SCL pin floats high, data should be stable. If the expected data on SDA is a '1' and the data sampled on the SDA pin = 0, then a bus collision has taken place. The master will set the Bus Collision Interrupt Flag, BCLIF, and reset the I<sup>2</sup>C port to its Idle state (Figure 18-27).

If a transmit was in progress when the bus collision occurred, the transmission is halted, the BF flag is cleared, the SDA and SCL lines are deasserted and the SSPBUF can be written to. When the user services the bus collision Interrupt Service Routine, and if the I<sup>2</sup>C bus is free, the user can resume communication by asserting a Start condition.

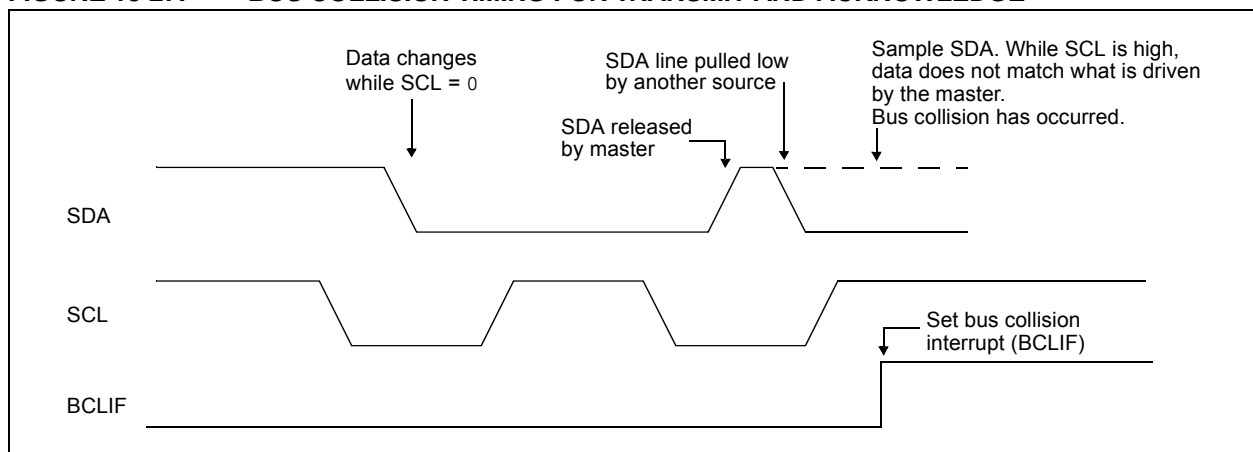
If a Start, Repeated Start, Stop or Acknowledge condition was in progress when the bus collision occurred, the condition is aborted, the SDA and SCL lines are deasserted, and the respective control bits in the SSPCON2 register, are cleared. When the user services the bus collision Interrupt Service Routine and if the I<sup>2</sup>C bus is free, the user can resume communication by asserting a Start condition.

The master will continue to monitor the SDA and SCL pins. If a Stop condition occurs, the SSPIF bit will be set.

A write to the SSPBUF will start the transmission of data at the first data bit, regardless of where the transmitter left off when the bus collision occurred.

In Multi-Master mode, the interrupt generation on the detection of Start and Stop conditions allows the determination of when the bus is free. Control of the I<sup>2</sup>C bus can be taken when the P bit is set in the SSPSTAT register, or the bus is Idle and the S and P bits are cleared.

**FIGURE 18-27: BUS COLLISION TIMING FOR TRANSMIT AND ACKNOWLEDGE**



# PIC18F87J72

## 18.4.17.1 Bus Collision During a Start Condition

During a Start condition, a bus collision occurs if:

- SDA or SCL are sampled low at the beginning of the Start condition (Figure 18-28).
- SCL is sampled low before SDA is asserted low (Figure 18-29).

During a Start condition, both the SDA and the SCL pins are monitored.

If the SDA pin is already low, or the SCL pin is already low, then all of the following occur:

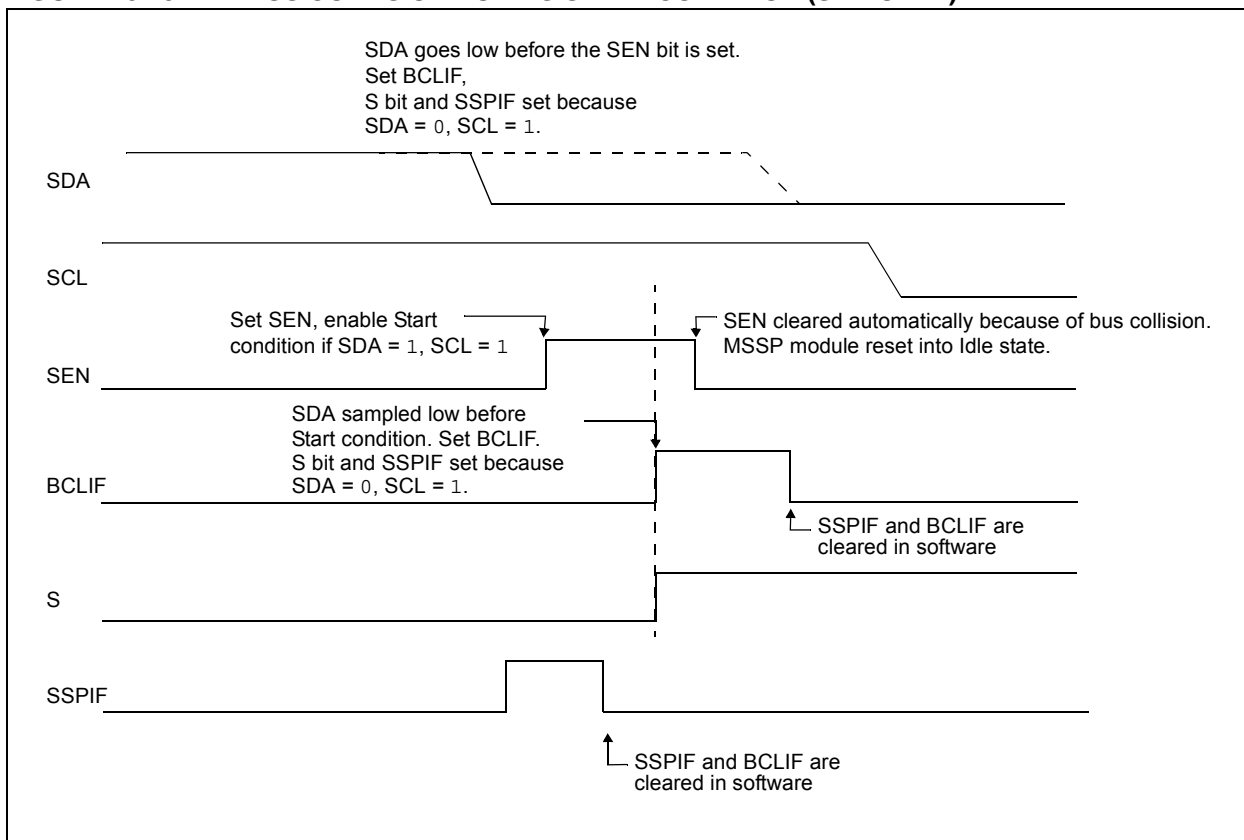
- the Start condition is aborted;
- the BCLIF flag is set; and
- the MSSP module is reset to its Idle state (Figure 18-28).

The Start condition begins with the SDA and SCL pins deasserted. When the SDA pin is sampled high, the Baud Rate Generator is loaded from SSPADD<6:0> and counts down to 0. If the SCL pin is sampled low while SDA is high, a bus collision occurs, because it is assumed that another master is attempting to drive a data '1' during the Start condition.

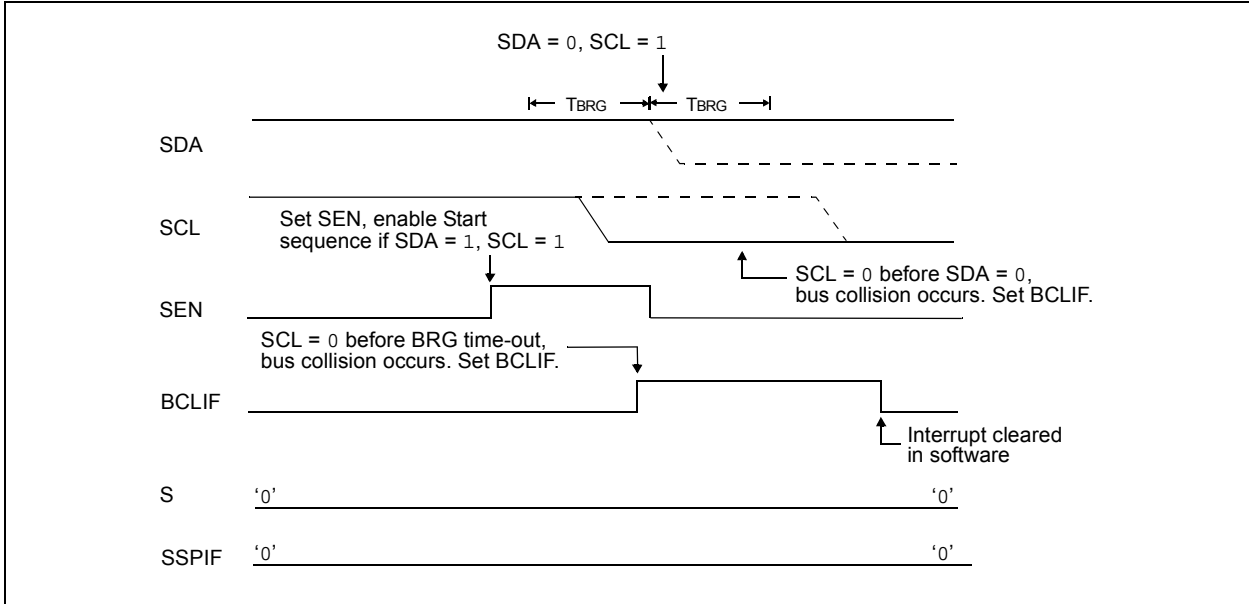
If the SDA pin is sampled low during this count, the BRG is reset and the SDA line is asserted early (Figure 18-30). If, however, a '1' is sampled on the SDA pin, the SDA pin is asserted low at the end of the BRG count. The Baud Rate Generator is then reloaded and counts down to 0. If the SCL pin is sampled as '0' during this time, a bus collision does not occur. At the end of the BRG count, the SCL pin is asserted low.

**Note:** The reason that bus collision is not a factor during a Start condition is that no two bus masters can assert a Start condition at the exact same time. Therefore, one master will always assert SDA before the other. This condition does not cause a bus collision because the two masters must be allowed to arbitrate the first address following the Start condition. If the address is the same, arbitration must be allowed to continue into the data portion, Repeated Start or Stop conditions.

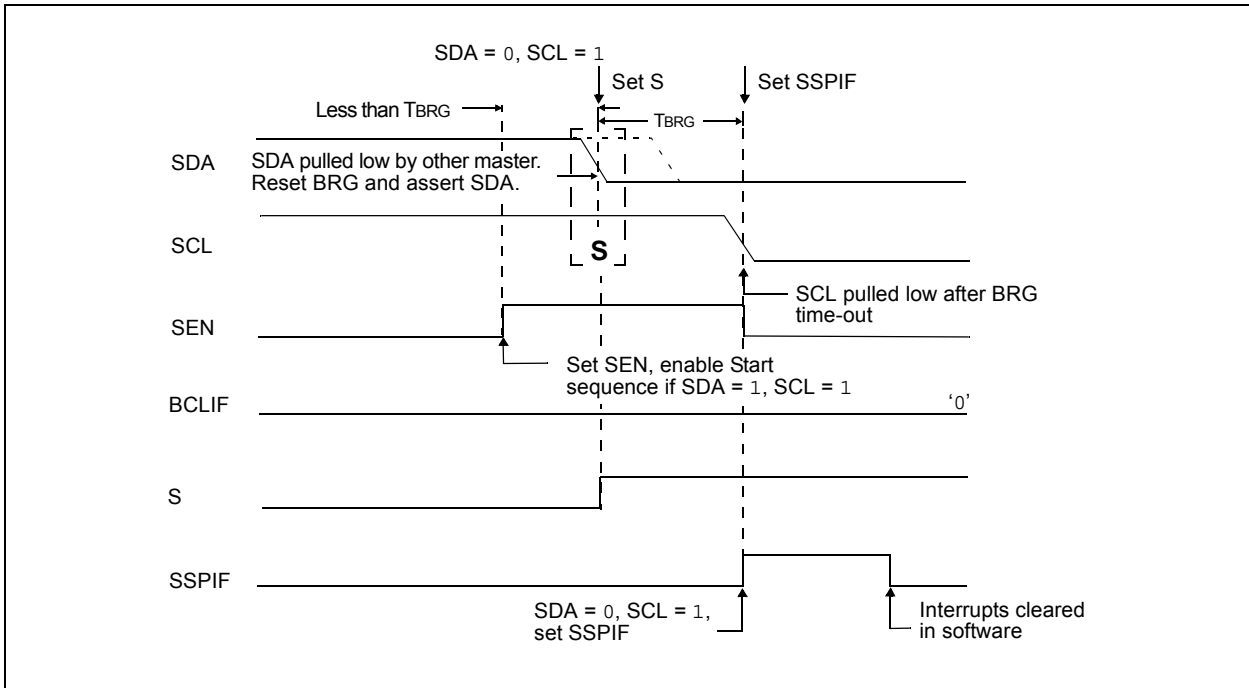
**FIGURE 18-28: BUS COLLISION DURING START CONDITION (SDA ONLY)**



**FIGURE 18-29: BUS COLLISION DURING START CONDITION (SCL = 0)**



**FIGURE 18-30: BRG RESET DUE TO SDA ARBITRATION DURING START CONDITION**



# PIC18F87J72

## 18.4.17.2 Bus Collision During a Repeated Start Condition

During a Repeated Start condition, a bus collision occurs if:

- A low level is sampled on SDA when SCL goes from low level to high level.
- SCL goes low before SDA is asserted low, indicating that another master is attempting to transmit a data '1'.

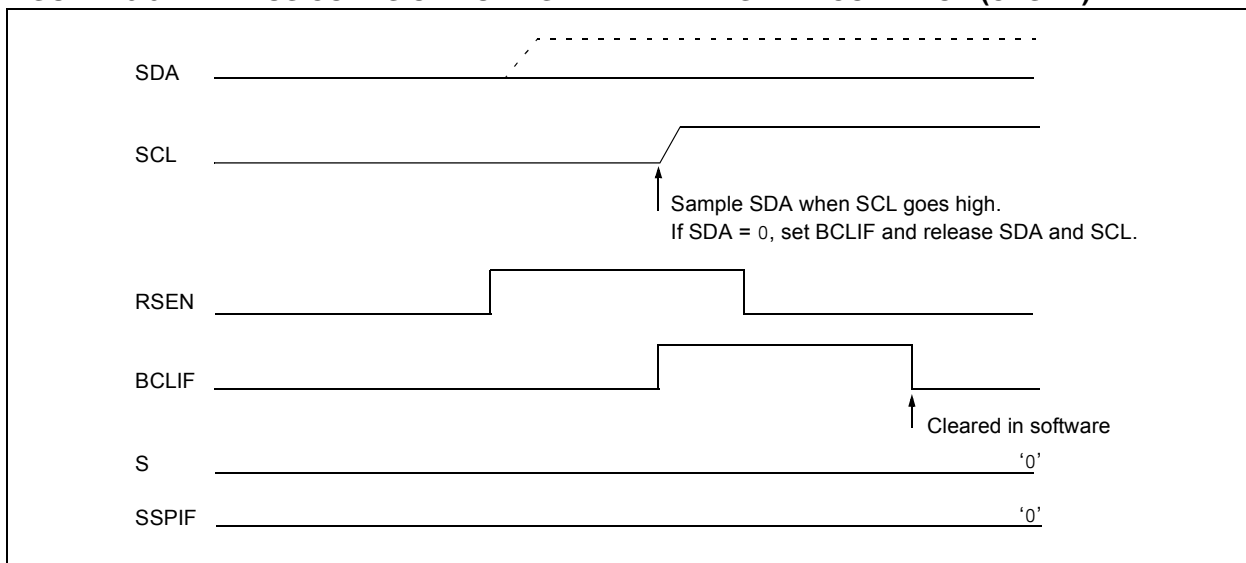
When the user deasserts SDA and the pin is allowed to float high, the BRG is loaded with SSPADD<6:0> and counts down to '0'. The SCL pin is then deasserted and when sampled high, the SDA pin is sampled.

If SDA is low, a bus collision has occurred (i.e., another master is attempting to transmit a data '0', see [Figure 18-31](#)). If SDA is sampled high, the BRG is reloaded and begins counting. If SDA goes from high-to-low before the BRG times out, no bus collision occurs because no two masters can assert SDA at exactly the same time.

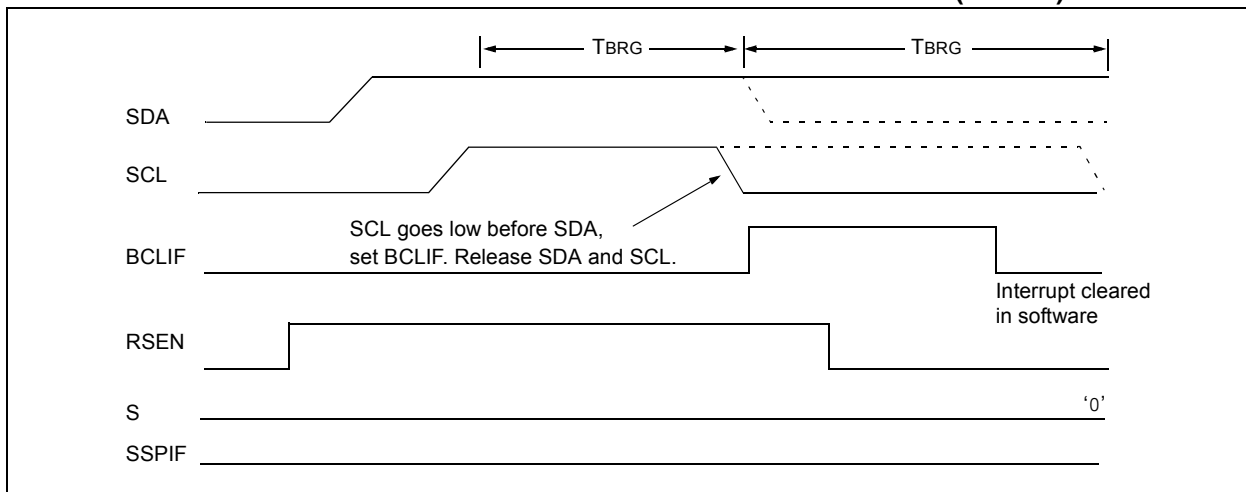
If SCL goes from high-to-low before the BRG times out and SDA has not already been asserted, a bus collision occurs. In this case, another master is attempting to transmit a data '1' during the Repeated Start condition (see [Figure 18-32](#)).

If, at the end of the BRG time-out, both SCL and SDA are still high, the SDA pin is driven low and the BRG is reloaded and begins counting. At the end of the count, regardless of the status of the SCL pin, the SCL pin is driven low and the Repeated Start condition is complete.

**FIGURE 18-31: BUS COLLISION DURING A REPEATED START CONDITION (CASE 1)**



**FIGURE 18-32: BUS COLLISION DURING REPEATED START CONDITION (CASE 2)**



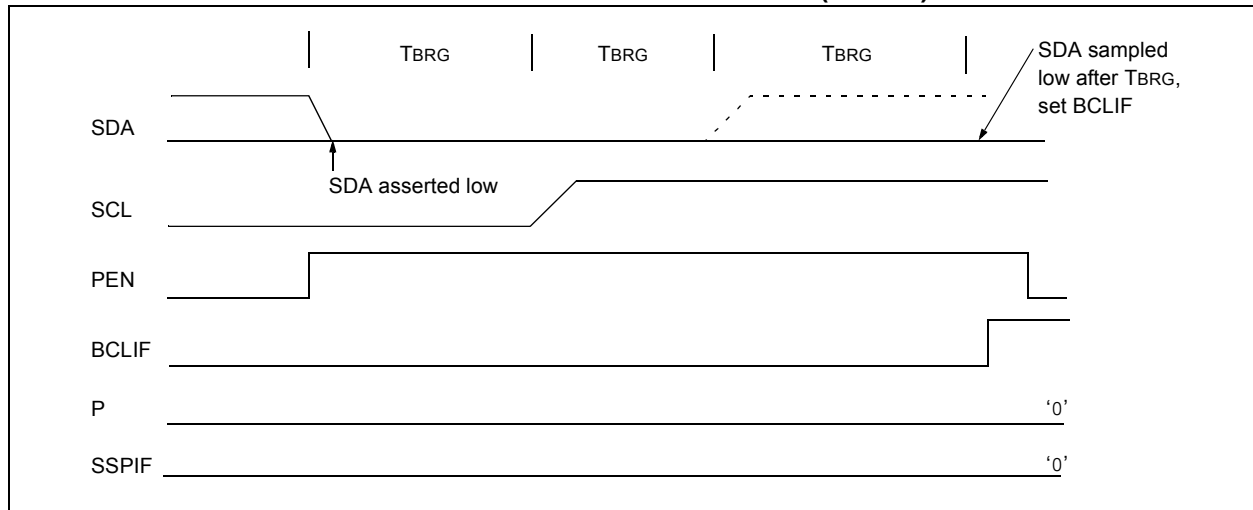
## 18.4.17.3 Bus Collision During a Stop Condition

Bus collision occurs during a Stop condition if:

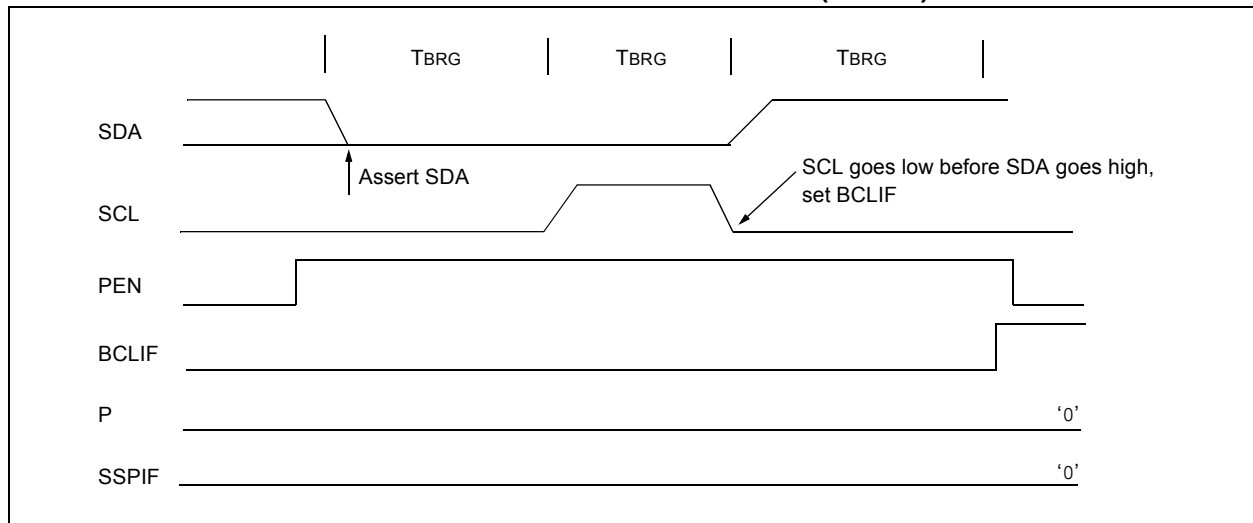
- After the SDA pin has been deasserted and allowed to float high, SDA is sampled low after the BRG has timed out.
- After the SCL pin is deasserted, SCL is sampled low before SDA goes high.

The Stop condition begins with SDA asserted low. When SDA is sampled low, the SCL pin is allowed to float. When the pin is sampled high (clock arbitration), the Baud Rate Generator is loaded with SSPADD<6:0> and counts down to 0. After the BRG times out, SDA is sampled. If SDA is sampled low, a bus collision has occurred. This is due to another master attempting to drive a data '0' (Figure 18-33). If the SCL pin is sampled low before SDA is allowed to float high, a bus collision occurs. This is another case of another master attempting to drive a data '0' (Figure 18-34).

**FIGURE 18-33: BUS COLLISION DURING A STOP CONDITION (CASE 1)**



**FIGURE 18-34: BUS COLLISION DURING A STOP CONDITION (CASE 2)**



# PIC18F87J72

**TABLE 18-5: REGISTERS ASSOCIATED WITH I<sup>2</sup>C OPERATION**

Name	Bit 7	Bit 6	Bit 5	Bit 4	Bit 3	Bit 2	Bit 1	Bit 0	Reset Values on Page
INTCON	GIE/GIEH	PEIE/GIEL	TMR0IE	INT0IE	RBIE	TMR0IF	INT0IF	RBIF	45
PIR1	—	ADIF	RC1IF	TX1IF	SSPIF	—	TMR2IF	TMR1IF	48
PIE1	—	ADIE	RC1IE	TX1IE	SSPIE	—	TMR2IE	TMR1IE	48
IPR1	—	ADIP	RC1IP	TX1IP	SSPIP	—	TMR2IP	TMR1IP	48
PIR2	OSCFIF	CMIF	—	—	BCLIF	LVDIF	TMR3IF	—	48
PIE2	OSCFIE	CMIE	—	—	BCLIE	LVDIE	TMR3IE	—	48
IPR2	OSCFIP	CMIP	—	—	BCLIP	LVDIP	TMR3IP	—	48
TRISC	TRISC7	TRISC6	TRISC5	TRISC4	TRISC3	TRISC2	TRISC1	TRISC0	48
SSPBUF	MSSP Receive Buffer/Transmit Register								46
SSPADD	MSSP Address Register (I <sup>2</sup> C Slave mode), MSSP Baud Rate Reload Register (I <sup>2</sup> C Master mode)								46
SSPCON1	WCOL	SSPOV	SSPEN	CKP	SSPM3	SSPM2	SSPM1	SSPM0	46
SSPCON2	GCEN	ACKSTAT	ACKDT	ACKEN	RCEN	PEN	RSEN	SEN	46
	GCEN	ACKSTAT	ADMSK5 <sup>(1)</sup>	ADMSK4 <sup>(1)</sup>	ADMSK3 <sup>(1)</sup>	ADMSK2 <sup>(1)</sup>	ADMSK1 <sup>(1)</sup>	SEN	
SSPSTAT	SMP	CKE	D/ $\bar{A}$	P	S	R/ $\bar{W}$	UA	BF	46

Legend: — = unimplemented, read as '0'. Shaded cells are not used by the MSSP module in I<sup>2</sup>C mode.

**Note 1:** Alternate bit definitions for use in I<sup>2</sup>C Slave mode operations only.

## 19.0 ENHANCED UNIVERSAL SYNCHRONOUS ASYNCHRONOUS RECEIVER TRANSMITTER (EUSART)

PIC18F87J72 family devices have three serial I/O modules: the MSSP module, discussed in the previous chapter and two Universal Synchronous Asynchronous Receiver Transmitter (USART) modules. (Generically, the USART is also known as a Serial Communications Interface or SCI.) The USART can be configured as a full-duplex asynchronous system that can communicate with peripheral devices, such as CRT terminals and personal computers. It can also be configured as a half-duplex synchronous system that can communicate with peripheral devices, such as A/D or D/A integrated circuits, serial EEPROMs, etc.

There are two distinct implementations of the USART module in these devices: the Enhanced USART (EUSART) discussed here and the Addressable USART discussed in the next chapter. For this device family, USART1 always refers to the EUSART, while USART2 is always the AUSART.

The EUSART and AUSART modules implement the same core features for serial communications; their basic operation is essentially the same. The EUSART module provides additional features, including Automatic Baud Rate Detection and calibration, automatic wake-up on Sync Break reception and 12-bit Break character transmit. These features make it ideally suited for use in Local Interconnect Network bus (LIN/J2602 bus) systems.

The EUSART can be configured in the following modes:

- Asynchronous (full-duplex) with:
  - Auto-wake-up on character reception
  - Auto-baud calibration
  - 12-bit Break character transmission
- Synchronous – Master (half-duplex) with selectable clock polarity
- Synchronous – Slave (half-duplex) with selectable clock polarity

The pins of the EUSART are multiplexed with the functions of PORTC (RC6/TX1/CK1/SEG27 and RC7/RX1/DT1/SEG28). In order to configure these pins as an EUSART:

- SPEN bit (RCSTA1<7>) must be set (= 1)
- TRISC<7> bit must be set (= 1)
- TRISC<6> bit must be set (= 1)

**Note:** The EUSART control will automatically reconfigure the pin from input to output as needed.

The driver for the TX1 output pin can also be optionally configured as an open-drain output. This feature allows the voltage level on the pin to be pulled to a higher level through an external pull-up resistor, and allows the output to communicate with external circuits without the need for additional level shifters.

The open-drain output option is controlled by the U1OD bit (LATG<6>). Setting this bit configures the pin for open-drain operation.

### 19.1 Control Registers

The operation of the Enhanced USART module is controlled through three registers:

- Transmit Status and Control Register 1 (TXSTA1)
- Receive Status and Control Register 1 (RCSTA1)
- Baud Rate Control Register 1 (BAUDCON1)

The registers are described in [Register 19-1](#), [Register 19-2](#) and [Register 19-3](#).

# PIC18F87J72

## REGISTER 19-1: TXSTA1: EUSART TRANSMIT STATUS AND CONTROL REGISTER

R/W-0	R/W-0	R/W-0	R/W-0	R/W-0	R/W-0	R-1	R/W-0
CSRC	TX9	TXEN <sup>(1)</sup>	SYNC	SENDB	BRGH	TRMT	TX9D
bit 7						bit 0	

### Legend:

R = Readable bit

W = Writable bit

U = Unimplemented bit, read as '0'

-n = Value at POR

'1' = Bit is set

'0' = Bit is cleared

x = Bit is unknown

- bit 7      **CSRC:** Clock Source Select bit  
Asynchronous mode:  
 Don't care.  
Synchronous mode:  
 1 = Master mode (clock generated internally from BRG)  
 0 = Slave mode (clock from external source)
- bit 6      **TX9:** 9-Bit Transmit Enable bit  
 1 = Selects 9-bit transmission  
 0 = Selects 8-bit transmission
- bit 5      **TXEN:** Transmit Enable bit<sup>(1)</sup>  
 1 = Transmit is enabled  
 0 = Transmit is disabled
- bit 4      **SYNC:** EUSART Mode Select bit  
 1 = Synchronous mode  
 0 = Asynchronous mode
- bit 3      **SENDB:** Send Break Character bit  
Asynchronous mode:  
 1 = Send Sync Break on next transmission (cleared by hardware upon completion)  
 0 = Sync Break transmission completed  
Synchronous mode:  
 Don't care.
- bit 2      **BRGH:** High Baud Rate Select bit  
Asynchronous mode:  
 1 = High speed  
 0 = Low speed  
Synchronous mode:  
 Unused in this mode.
- bit 1      **TRMT:** Transmit Shift Register Status bit  
 1 = TSR is empty  
 0 = TSR is full
- bit 0      **TX9D:** 9th bit of Transmit Data  
 Can be address/data bit or a parity bit.

**Note 1:** SREN/CREN overrides TXEN in Sync mode.



## REGISTER 19-2: RCSTA1: EUSART RECEIVE STATUS AND CONTROL REGISTER

R/W-0	R/W-0	R/W-0	R/W-0	R/W-0	R-0	R-0	R-x
SPEN	RX9	SREN	CREN	ADDEN	FERR	OERR	RX9D
bit 7							bit 0

### Legend:

R = Readable bit  
-n = Value at POR

W = Writable bit  
'1' = Bit is set

U = Unimplemented bit, read as '0'  
'0' = Bit is cleared

x = Bit is unknown

- bit 7      **SPEN:** Serial Port Enable bit  
1 = Serial port is enabled  
0 = Serial port is disabled (held in Reset)
- bit 6      **RX9:** 9-Bit Receive Enable bit  
1 = Selects 9-bit reception  
0 = Selects 8-bit reception
- bit 5      **SREN:** Single Receive Enable bit  
Asynchronous mode:  
Don't care.  
Synchronous mode – Master:  
1 = Enables single receive  
0 = Disables single receive  
This bit is cleared after reception is complete.  
Synchronous mode – Slave:  
Don't care.
- bit 4      **CREN:** Continuous Receive Enable bit  
Asynchronous mode:  
1 = Enables receiver  
0 = Disables receiver  
Synchronous mode:  
1 = Enables continuous receive until enable bit, CREN, is cleared (CREN overrides SREN)  
0 = Disables continuous receive
- bit 3      **ADDEN:** Address Detect Enable bit  
Asynchronous mode 9-bit (RX9 = 1):  
1 = Enables address detection, enables interrupt and loads the receive buffer when RSR<8> is set  
0 = Disables address detection, all bytes are received and ninth bit can be used as parity bit  
Asynchronous mode 9-bit (RX9 = 0):  
Don't care.
- bit 2      **FERR:** Framing Error bit  
1 = Framing error (can be cleared by reading the RCREG1 register and receiving the next valid byte)  
0 = No framing error
- bit 1      **OERR:** Overrun Error bit  
1 = Overrun error (can be cleared by clearing bit, CREN)  
0 = No overrun error
- bit 0      **RX9D:** 9th bit of Received Data  
This can be address/data bit or a parity bit and must be calculated by user firmware.

# PIC18F87J72

## REGISTER 19-3: BAUDCON1: BAUD RATE CONTROL REGISTER 1

R/W-0	R-1	R/W - 0	R/W-0	R/W-0	U-0	R/W-0	R/W-0
ABDOVF	RCMT	RXDTP	TXCKP	BRG16	—	WUE	ABDEN
bit 7							bit 0

### Legend:

R = Readable bit

W = Writable bit

U = Unimplemented bit, read as '0'

-n = Value at POR

'1' = Bit is set

'0' = Bit is cleared

x = Bit is unknown

- bit 7      **ABDOVF**: Auto-Baud Acquisition Rollover Status bit  
 1 = A BRG rollover has occurred during Auto-Baud Rate Detect mode (must be cleared in software)  
 0 = No BRG rollover has occurred
- bit 6      **RCMT**: Receive Operation Idle Status bit  
 1 = Receive operation is Idle  
 0 = Receive operation is active
- bit 5      **RXDTP**: Received Data Polarity Select bit (Asynchronous mode only)  
 1 = RXx data is inverted  
 0 = RXx data is not inverted
- bit 4      **TXCKP**: Clock and Data Polarity Select bit  
Asynchronous mode:  
 1 = Transmit idle state is low  
 0 = Transmit idle state is high  
Synchronous mode:  
 1 = CKx clock idle state is high  
 0 = CKx clock idle state is low
- bit 3      **BRG16**: 16-Bit Baud Rate Register Enable bit  
 1 = 16-bit Baud Rate Generator – SPBRGH1 and SPBRG1  
 0 = 8-bit Baud Rate Generator – SPBRG1 only (Compatible mode), SPBRGH1 value is ignored
- bit 2      **Unimplemented**: Read as '0'
- bit 1      **WUE**: Wake-up Enable bit  
Asynchronous mode:  
 1 = EUSART will continue to sample the RX1 pin – interrupt generated on falling edge; bit cleared in hardware on following rising edge  
 0 = RX1 pin is not monitored or a rising edge detected  
Synchronous mode:  
 Unused in this mode.
- bit 0      **ABDEN**: Auto-Baud Detect Enable bit  
Asynchronous mode:  
 1 = Enable baud rate measurement on the next character. Requires reception of a Sync field (55h); cleared in hardware upon completion.  
 0 = Baud rate measurement is disabled or completed  
Synchronous mode:  
 Unused in this mode.

## 19.2 EUSART Baud Rate Generator (BRG)

The BRG is a dedicated, 8-bit or 16-bit generator that supports both the Asynchronous and Synchronous modes of the EUSART. By default, the BRG operates in 8-bit mode; setting the BRG16 bit (BAUDCON1<3>) selects 16-bit mode.

The SPBRGH1:SPBRG1 register pair controls the period of a free-running timer. In Asynchronous mode, BRGH (TXSTA1<2>) and BRG16 (BAUDCON1<3>) bits also control the baud rate. In Synchronous mode, BRGH is ignored. Table 19-1 shows the formula for computation of the baud rate for different EUSART modes that only apply in Master mode (internally generated clock).

Given the desired baud rate and Fosc, the nearest integer value for the SPBRGH1:SPBRG1 registers can be calculated using the formulas in Table 19-1. From this, the error in baud rate can be determined. An example calculation is shown in Example 19-1. Typical baud rates and error values for the various Asynchronous modes are shown in Table 19-3. It may be advantageous to use

the high baud rate (BRGH = 1) or the 16-bit BRG to reduce the baud rate error, or achieve a slow baud rate for a fast oscillator frequency.

Writing a new value to the SPBRGH1:SPBRG1 registers causes the BRG timer to be reset (or cleared). This ensures the BRG does not wait for a timer overflow before outputting the new baud rate. SPBRGH1:SPBRG1 values of 0000h and 0001h are not supported in Synchronous mode.

### 19.2.1 OPERATION IN POWER-MANAGED MODES

The device clock is used to generate the desired baud rate. When one of the power-managed modes is entered, the new clock source may be operating at a different frequency. This may require an adjustment to the value in the SPBRG1 register pair.

### 19.2.2 SAMPLING

The data on the RX1 pin is sampled three times by a majority detect circuit to determine if a high or a low level is present at the RX1 pin.

**TABLE 19-1: BAUD RATE FORMULAS**

Configuration Bits			BRG/EUSART Mode	Baud Rate Formula
SYNC	BRG16	BRGH		
0	0	0	8-bit/Asynchronous	Fosc/[64 (n + 1)]
0	0	1	8-bit/Asynchronous	
0	1	0	16-bit/Asynchronous	Fosc/[16 (n + 1)]
0	1	1	16-bit/Asynchronous	
1	0	x	8-bit/Synchronous	Fosc/[4 (n + 1)]
1	1	x	16-bit/Synchronous	

Legend: x = Don't care, n = Value of SPBRGH1:SPBRG1 register pair

### EXAMPLE 19-1: CALCULATING BAUD RATE ERROR

For a device with Fosc of 16 MHz, desired baud rate of 9600, Asynchronous mode, 8-bit BRG:

$$\text{Desired Baud Rate} = F_{osc} / (64 ([SPBRGH1:SPBRG1] + 1))$$

Solving for SPBRGH1:SPBRG1:

$$\begin{aligned} X &= ((F_{osc} / \text{Desired Baud Rate}) / 64) - 1 \\ &= ((16000000 / 9600) / 64) - 1 \\ &= [25.042] = 25 \end{aligned}$$

$$\begin{aligned} \text{Calculated Baud Rate} &= 16000000 / (64 (25 + 1)) \\ &= 9615 \end{aligned}$$

$$\begin{aligned} \text{Error} &= (\text{Calculated Baud Rate} - \text{Desired Baud Rate}) / \text{Desired Baud Rate} \\ &= (9615 - 9600) / 9600 = 0.16\% \end{aligned}$$

# PIC18F87J72

**TABLE 19-2: REGISTERS ASSOCIATED WITH THE BAUD RATE GENERATOR**

Name	Bit 7	Bit 6	Bit 5	Bit 4	Bit 3	Bit 2	Bit 1	Bit 0	Reset Values on Page
TXSTA1	CSRC	TX9	TXEN	SYNC	SENDB	BRGH	TRMT	TX9D	47
RCSTA1	SPEN	RX9	SREN	CREN	ADDEN	FERR	OERR	RX9D	47
BAUDCON1	ABDOVF	RCMT	RXDTP	TXCKP	BRG16	—	WUE	ABDEN	49
SPBRGH1	EUSART Baud Rate Generator Register High Byte								49
SPBRG1	EUSART Baud Rate Generator Register Low Byte								47

Legend: — = unimplemented, read as '0'. Shaded cells are not used by the BRG.

**TABLE 19-3: BAUD RATES FOR ASYNCHRONOUS MODES**

BAUD RATE (K)	SYNC = 0, BRGH = 0, BRG16 = 0											
	Fosc = 40.000 MHz			Fosc = 20.000 MHz			Fosc = 10.000 MHz			Fosc = 8.000 MHz		
	Actual Rate (K)	% Error	SPBRG value (decimal)	Actual Rate (K)	% Error	SPBRG value (decimal)	Actual Rate (K)	% Error	SPBRG value (decimal)	Actual Rate (K)	% Error	SPBRG value (decimal)
0.3	—	—	—	—	—	—	—	—	—	—	—	—
1.2	—	—	—	1.221	1.73	255	1.202	0.16	129	1.201	-0.16	103
2.4	2.441	1.73	255	2.404	0.16	129	2.404	0.16	64	2.403	-0.16	51
9.6	9.615	0.16	64	9.766	1.73	31	9.766	1.73	15	9.615	-0.16	12
19.2	19.531	1.73	31	19.531	1.73	15	19.531	1.73	7	—	—	—
57.6	56.818	-1.36	10	62.500	8.51	4	52.083	-9.58	2	—	—	—
115.2	125.000	8.51	4	104.167	-9.58	2	78.125	-32.18	1	—	—	—

BAUD RATE (K)	SYNC = 0, BRGH = 0, BRG16 = 0								
	Fosc = 4.000 MHz			Fosc = 2.000 MHz			Fosc = 1.000 MHz		
	Actual Rate (K)	% Error	SPBRG value (decimal)	Actual Rate (K)	% Error	SPBRG value (decimal)	Actual Rate (K)	% Error	SPBRG value (decimal)
0.3	0.300	0.16	207	0.300	-0.16	103	0.300	-0.16	51
1.2	1.202	0.16	51	1.201	-0.16	25	1.201	-0.16	12
2.4	2.404	0.16	25	2.403	-0.16	12	—	—	—
9.6	8.929	-6.99	6	—	—	—	—	—	—
19.2	20.833	8.51	2	—	—	—	—	—	—
57.6	62.500	8.51	0	—	—	—	—	—	—
115.2	62.500	-45.75	0	—	—	—	—	—	—

BAUD RATE (K)	SYNC = 0, BRGH = 1, BRG16 = 0											
	Fosc = 40.000 MHz			Fosc = 20.000 MHz			Fosc = 10.000 MHz			Fosc = 8.000 MHz		
	Actual Rate (K)	% Error	SPBRG value (decimal)	Actual Rate (K)	% Error	SPBRG value (decimal)	Actual Rate (K)	% Error	SPBRG value (decimal)	Actual Rate (K)	% Error	SPBRG value (decimal)
0.3	—	—	—	—	—	—	—	—	—	—	—	—
1.2	—	—	—	—	—	—	—	—	—	—	—	—
2.4	—	—	—	—	—	—	2.441	1.73	255	2.403	-0.16	207
9.6	9.766	1.73	255	9.615	0.16	129	9.615	0.16	64	9.615	-0.16	51
19.2	19.231	0.16	129	19.231	0.16	64	19.531	1.73	31	19.230	-0.16	25

**TABLE 19-3: BAUD RATES FOR ASYNCHRONOUS MODES (CONTINUED)**

57.6	58.140	0.94	42	56.818	-1.36	21	56.818	-1.36	10	55.555	3.55	8
115.2	113.636	-1.36	21	113.636	-1.36	10	125.000	8.51	4	—	—	—

BAUD RATE (K)	SYNC = 0, BRGH = 1, BRG16 = 0								
	Fosc = 4.000 MHz			Fosc = 2.000 MHz			Fosc = 1.000 MHz		
	Actual Rate (K)	% Error	SPBRG value (decimal)	Actual Rate (K)	% Error	SPBRG value (decimal)	Actual Rate (K)	% Error	SPBRG value (decimal)
0.3	—	—	—	—	—	—	0.300	-0.16	207
1.2	1.202	0.16	207	1.201	-0.16	103	1.201	-0.16	51
2.4	2.404	0.16	103	2.403	-0.16	51	2.403	-0.16	25
9.6	9.615	0.16	25	9.615	-0.16	12	—	—	—
19.2	19.231	0.16	12	—	—	—	—	—	—
57.6	62.500	8.51	3	—	—	—	—	—	—
115.2	125.000	8.51	1	—	—	—	—	—	—

BAUD RATE (K)	SYNC = 0, BRGH = 0, BRG16 = 1											
	Fosc = 40.000 MHz			Fosc = 20.000 MHz			Fosc = 10.000 MHz			Fosc = 8.000 MHz		
	Actual Rate (K)	% Error	SPBRG value (decimal)	Actual Rate (K)	% Error	SPBRG value (decimal)	Actual Rate (K)	% Error	SPBRG value (decimal)	Actual Rate (K)	% Error	SPBRG value (decimal)
0.3	0.300	0.00	8332	0.300	0.02	4165	0.300	0.02	2082	0.300	-0.04	1665
1.2	1.200	0.02	2082	1.200	-0.03	1041	1.200	-0.03	520	1.201	-0.16	415
2.4	2.402	0.06	1040	2.399	-0.03	520	2.404	0.16	259	2.403	-0.16	207
9.6	9.615	0.16	259	9.615	0.16	129	9.615	0.16	64	9.615	-0.16	51
19.2	19.231	0.16	129	19.231	0.16	64	19.531	1.73	31	19.230	-0.16	25
57.6	58.140	0.94	42	56.818	-1.36	21	56.818	-1.36	10	55.555	3.55	8
115.2	113.636	-1.36	21	113.636	-1.36	10	125.000	8.51	4	—	—	—

BAUD RATE (K)	SYNC = 0, BRGH = 0, BRG16 = 1								
	Fosc = 4.000 MHz			Fosc = 2.000 MHz			Fosc = 1.000 MHz		
	Actual Rate (K)	% Error	SPBRG value (decimal)	Actual Rate (K)	% Error	SPBRG value (decimal)	Actual Rate (K)	% Error	SPBRG value (decimal)
0.3	0.300	0.04	832	0.300	-0.16	415	0.300	-0.16	207
1.2	1.202	0.16	207	1.201	-0.16	103	1.201	-0.16	51
2.4	2.404	0.16	103	2.403	-0.16	51	2.403	-0.16	25
9.6	9.615	0.16	25	9.615	-0.16	12	—	—	—
19.2	19.231	0.16	12	—	—	—	—	—	—
57.6	62.500	8.51	3	—	—	—	—	—	—
115.2	125.000	8.51	1	—	—	—	—	—	—

BAUD RATE (K)	SYNC = 0, BRGH = 1, BRG16 = 1 or SYNC = 1, BRG16 = 1											
	Fosc = 40.000 MHz			Fosc = 20.000 MHz			Fosc = 10.000 MHz			Fosc = 8.000 MHz		
	Actual Rate (K)	% Error	SPBRG value (decimal)	Actual Rate (K)	% Error	SPBRG value (decimal)	Actual Rate (K)	% Error	SPBRG value (decimal)	Actual Rate (K)	% Error	SPBRG value (decimal)
0.3	0.300	0.00	33332	0.300	0.00	16665	0.300	0.00	8332	0.300	-0.01	6665

# PIC18F87J72

**TABLE 19-3: BAUD RATES FOR ASYNCHRONOUS MODES (CONTINUED)**

1.2	1.200	0.00	8332	1.200	0.02	4165	1.200	0.02	2082	1.200	-0.04	1665
2.4	2.400	0.02	4165	2.400	0.02	2082	2.402	0.06	1040	2.400	-0.04	832
9.6	9.606	0.06	1040	9.596	-0.03	520	9.615	0.16	259	9.615	-0.16	207
19.2	19.193	-0.03	520	19.231	0.16	259	19.231	0.16	129	19.230	-0.16	103
57.6	57.803	0.35	172	57.471	-0.22	86	58.140	0.94	42	57.142	0.79	34
115.2	114.943	-0.22	86	116.279	0.94	42	113.636	-1.36	21	117.647	-2.12	16

BAUD RATE (K)	SYNC = 0, BRGH = 1, BRG16 = 1 or SYNC = 1, BRG16 = 1								
	Fosc = 4.000 MHz			Fosc = 2.000 MHz			Fosc = 1.000 MHz		
	Actual Rate (K)	% Error	SPBRG value (decimal)	Actual Rate (K)	% Error	SPBRG value (decimal)	Actual Rate (K)	% Error	SPBRG value (decimal)
0.3	0.300	0.01	3332	0.300	-0.04	1665	0.300	-0.04	832
1.2	1.200	0.04	832	1.201	-0.16	415	1.201	-0.16	207
2.4	2.404	0.16	415	2.403	-0.16	207	2.403	-0.16	103
9.6	9.615	0.16	103	9.615	-0.16	51	9.615	-0.16	25
19.2	19.231	0.16	51	19.230	-0.16	25	19.230	-0.16	12
57.6	58.824	2.12	16	55.555	3.55	8	—	—	—
115.2	111.111	-3.55	8	—	—	—	—	—	—

## 19.2.3 AUTO-BAUD RATE DETECT

The Enhanced USART module supports the automatic detection and calibration of baud rate. This feature is active only in Asynchronous mode and while the WUE bit is clear.

The automatic baud rate measurement sequence (Figure 19-1) begins whenever a Start bit is received and the ABDEN bit is set. The calculation is self-averaging.

In the Auto-Baud Rate Detect (ABD) mode, the clock to the BRG is reversed. Rather than the BRG clocking the incoming RX1 signal, the RX1 signal is timing the BRG. In ABD mode, the internal Baud Rate Generator is used as a counter to time the bit period of the incoming serial byte stream.

Once the ABDEN bit is set, the state machine will clear the BRG and look for a Start bit. The Auto-Baud Rate Detect must receive a byte with the value, 55h (ASCII “U”, which is also the LIN/J2602 bus Sync character), in order to calculate the proper bit rate. The measurement is taken over both a low and a high bit time in order to minimize any effects caused by asymmetry of the incoming signal. After a Start bit, the SPBRG1 begins counting up, using the preselected clock source on the first rising edge of RX1. After eight bits on the RX1 pin or the fifth rising edge, an accumulated value totalling the proper BRG period is left in the SPBRGH1:SPBRG1 register pair. Once the 5th edge is seen (this should correspond to the Stop bit), the ABDEN bit is automatically cleared.

If a rollover of the BRG occurs (an overflow from FFFFh to 0000h), the event is trapped by the ABDOVF Status bit (BAUDCON1<7>). It is set in hardware by BRG rollovers and can be set or cleared by the user in software. ABD mode remains active after rollover events and the ABDEN bit remains set (Figure 19-2).

While calibrating the baud rate period, the BRG registers are clocked at 1/8th the preconfigured clock rate. Note that the BRG clock is configured by the BRG16 and BRGH bits. The BRG16 bit (BAUDCON1<3>) must be set to use the SPBRG1 and SPBRGH1 registers as a 16-bit counter. This allows the user to verify that no carry occurred for 8-bit modes by checking for 00h in the SPBRGH1 register. Refer to Table 19-4 for counter clock rates to the BRG.

While the ABD sequence takes place, the EUSART state machine is held in Idle. The RC1IF interrupt is set once the fifth rising edge on RX1 is detected. The value in the RCREG1 needs to be read to clear the RC1IF interrupt. The contents of RCREG1 should be discarded.

**Note 1:** If the WUE bit is set with the ABDEN bit, Auto-Baud Rate Detection will occur on the byte *following* the Break character.

**2:** It is up to the user to determine that the incoming character baud rate is within the range of the selected BRG clock source. Some combinations of oscillator frequency and EUSART baud rates are not possible due to bit error rates. Overall system timing and communication baud rates must be taken into consideration when using the Auto-Baud Rate Detection feature.

**TABLE 19-4: BRG COUNTER CLOCK RATES**

BRG16	BRGH	BRG Counter Clock
0	0	Fosc/512
0	1	Fosc/128
1	0	Fosc/128
1	1	Fosc/32

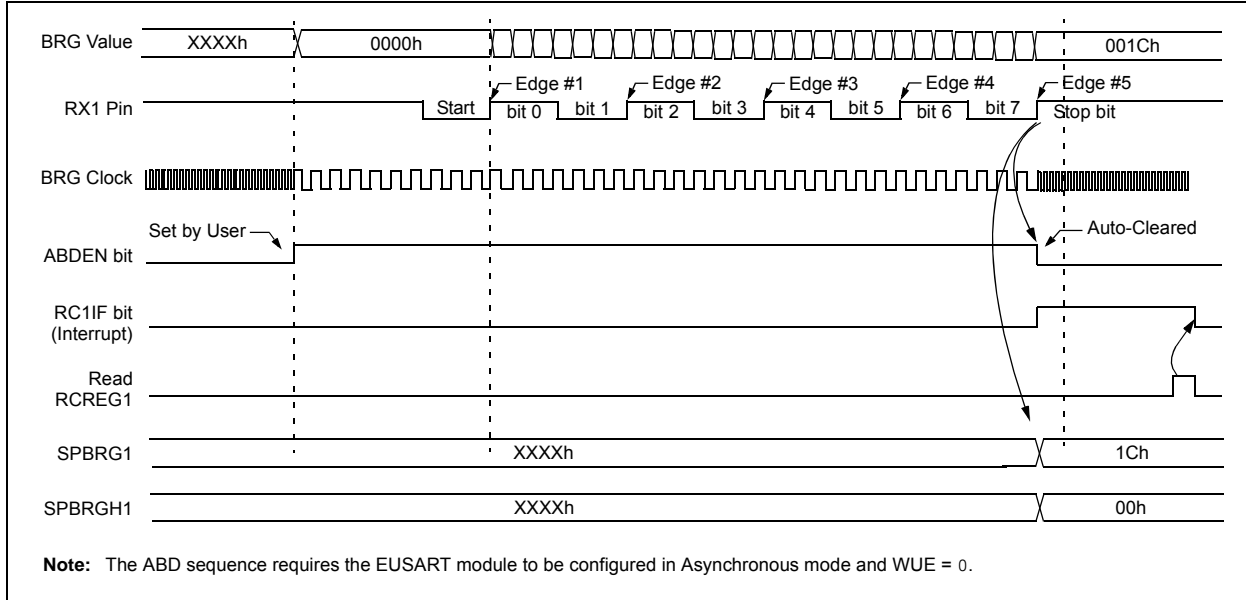
**Note:** During the ABD sequence, SPBRG1 and SPBRGH1 are both used as a 16-bit counter, independent of the BRG16 setting.

### 19.2.3.1 ABD and EUSART Transmission

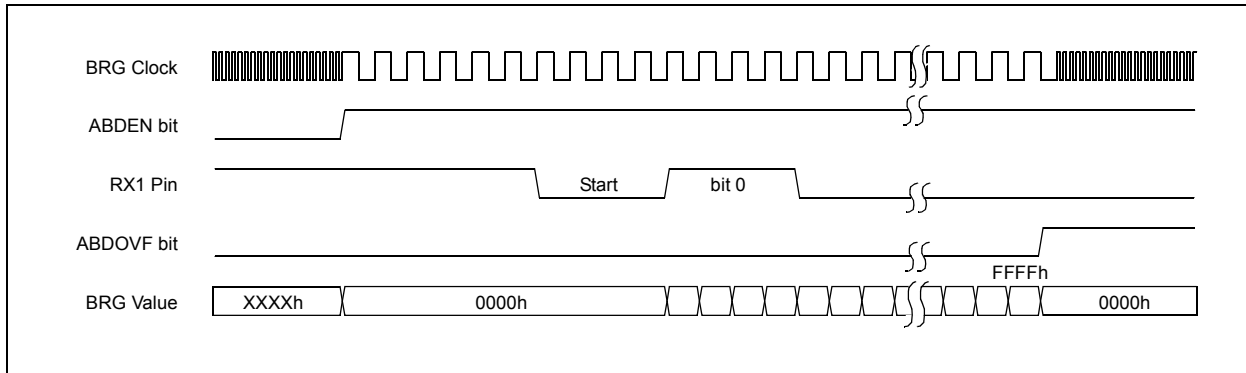
Since the BRG clock is reversed during ABD acquisition, the EUSART transmitter cannot be used during ABD. This means that whenever the ABDEN bit is set, TXREG1 cannot be written to. Users should also ensure that ABDEN does not become set during a transmit sequence. Failing to do this may result in unpredictable EUSART operation.

# PIC18F87J72

**FIGURE 19-1: AUTOMATIC BAUD RATE CALCULATION**



**FIGURE 19-2: BRG OVERFLOW SEQUENCE**





## 19.3 EUSART Asynchronous Mode

The Asynchronous mode of operation is selected by clearing the SYNC bit (TXSTA1<4>). In this mode, the EUSART uses standard Non-Return-to-Zero (NRZ) format (one Start bit, eight or nine data bits and one Stop bit). The most common data format is eight bits. An on-chip dedicated 8-bit/16-bit Baud Rate Generator can be used to derive standard baud rate frequencies from the oscillator.

The EUSART transmits and receives the LSb first. The EUSART's transmitter and receiver are functionally independent, but use the same data format and baud rate. The Baud Rate Generator produces a clock, either x16 or x64 of the bit shift rate, depending on the BRGH and BRG16 bits (TXSTA1<2> and BAUDCON1<3>). Parity is not supported by the hardware but can be implemented in software and stored as the 9th data bit.

When operating in Asynchronous mode, the EUSART module consists of the following important elements:

- Baud Rate Generator
- Sampling Circuit
- Asynchronous Transmitter
- Asynchronous Receiver
- Auto-Wake-up on Sync Break Character
- 12-Bit Break Character Transmit
- Auto-Baud Rate Detection

### 19.3.1 EUSART ASYNCHRONOUS TRANSMITTER

The EUSART transmitter block diagram is shown in Figure 19-3. The heart of the transmitter is the Transmit (Serial) Shift register (TSR). The Shift register obtains its data from the Read/Write Transmit Buffer register, TXREG1. The TXREG1 register is loaded with data in software. The TSR register is not loaded until the Stop bit has been transmitted from the previous load. As soon as the Stop bit is transmitted, the TSR is loaded with new data from the TXREG1 register (if available).

Once the TXREG1 register transfers the data to the TSR register (occurs in one T<sub>cy</sub>), the TXREG1 register is empty and the TX1IF flag bit (PIR1<4>) is set. This interrupt can be enabled or disabled by setting or clearing the interrupt enable bit, TX1IE (PIE1<4>). TX1IF will be set regardless of the state of TX1IE; it cannot be cleared in software. TX1IF is also not cleared immediately upon loading TXREG1, but becomes valid in the second instruction cycle following the load instruction. Polling TX1IF immediately following a load of TXREG1 will return invalid results.

While TX1IF indicates the status of the TXREG1 register, another bit, TRMT (TXSTA1<1>), shows the status of the TSR register. TRMT is a read-only bit which is set when the TSR register is empty. No interrupt logic is tied to this bit, so the user has to poll this bit in order to determine if the TSR register is empty.

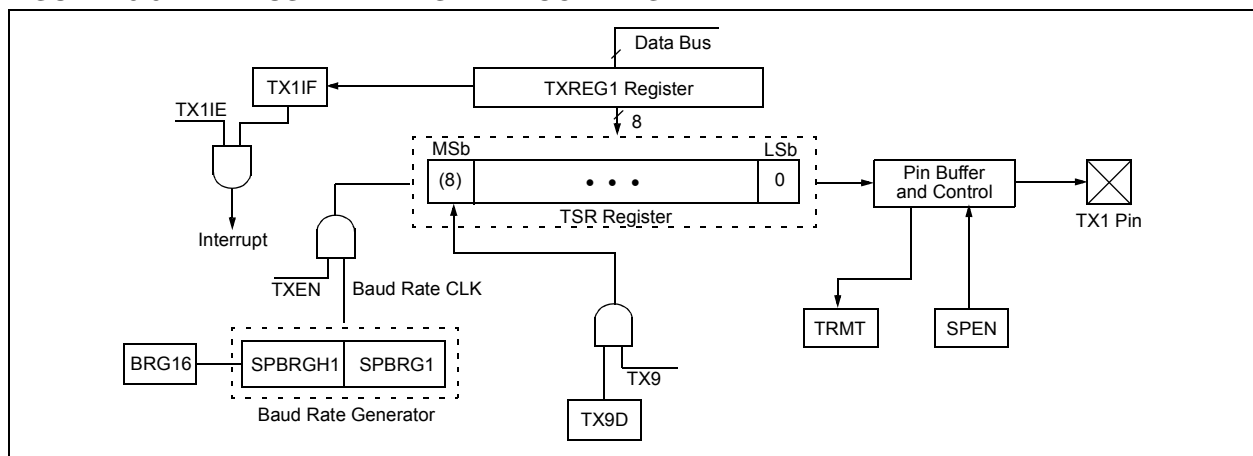
**Note 1:** The TSR register is not mapped in data memory so it is not available to the user.

**2:** Flag bit, TX1IF, is set when enable bit, TXEN, is set.

To set up an Asynchronous Transmission:

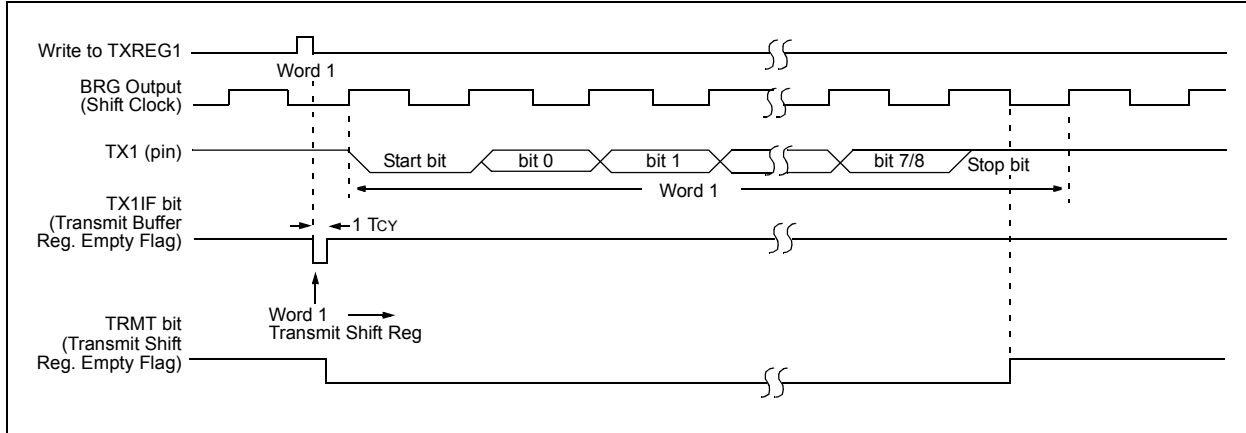
1. Initialize the SPBRGH1:SPBRG1 registers for the appropriate baud rate. Set or clear the BRGH and BRG16 bits, as required, to achieve the desired baud rate.
2. Enable the asynchronous serial port by clearing bit, SYNC, and setting bit, SPEN.
3. If interrupts are desired, set enable bit, TX1IE.
4. If 9-bit transmission is desired, set transmit bit, TX9; can be used as address/data bit.
5. Enable the transmission by setting bit, TXEN, which will also set bit, TX1IF.
6. If 9-bit transmission is selected, the ninth bit should be loaded in bit, TX9D.
7. Load data to the TXREG1 register (starts transmission).
8. If using interrupts, ensure that the GIE and PEIE bits in the INTCON register (INTCON<7:6>) are set.

**FIGURE 19-3: EUSART TRANSMIT BLOCK DIAGRAM**

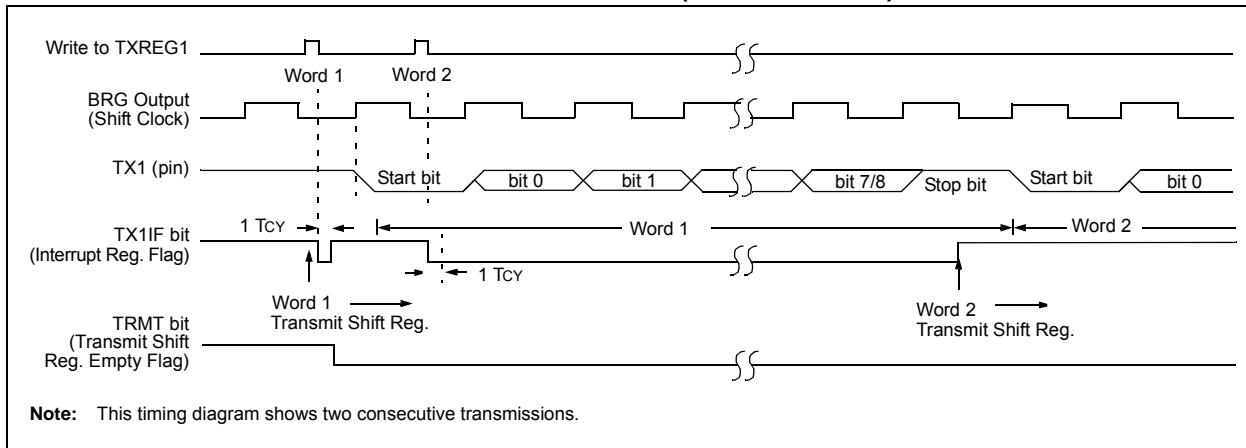


# PIC18F87J72

**FIGURE 19-4: ASYNCHRONOUS TRANSMISSION**



**FIGURE 19-5: ASYNCHRONOUS TRANSMISSION (BACK TO BACK)**



**TABLE 19-5: REGISTERS ASSOCIATED WITH ASYNCHRONOUS TRANSMISSION**

Name	Bit 7	Bit 6	Bit 5	Bit 4	Bit 3	Bit 2	Bit 1	Bit 0	Reset Values on Page
INTCON	GIE/GIEH	PEIE/GIE L	TMR0IE	INT0IE	RBIE	TMR0IF	INT0IF	RBIF	45
PIR1	—	ADIF	RC1IF	TX1IF	SSPIF	—	TMR2IF	TMR1IF	48
PIE1	—	ADIE	RC1IE	TX1IE	SSPIE	—	TMR2IE	TMR1IE	48
IPR1	—	ADIP	RC1IP	TX1IP	SSPIP	—	TMR2IP	TMR1IP	48
RCSTA1	SPEN	RX9	SREN	CREN	ADDEN	FERR	OERR	RX9D	47
TXREG1	EUSART Transmit Register								47
TXSTA1	CSRC	TX9	TXEN	SYNC	SENDB	BRGH	TRMT	TX9D	47
BAUDCON1	ABDOVF	RCMT	RXDTP	TXCKP	BRG16	—	WUE	ABDEN	49
SPBRGH1	EUSART Baud Rate Generator Register High Byte								49
SPBRG1	EUSART Baud Rate Generator Register Low Byte								47
LATG	U2OD	U1OD	—	LATG4	LATG3	LATG2	LATG1	LATG0	48

Legend: — = unimplemented locations read as '0'. Shaded cells are not used for asynchronous transmission.

## 19.3.2 EUSART ASYNCHRONOUS RECEIVER

The receiver block diagram is shown in [Figure 19-6](#). The data is received on the RX1 pin and drives the data recovery block. The data recovery block is actually a high-speed shifter operating at x16 times the baud rate, whereas the main receive serial shifter operates at the bit rate or at Fosc. This mode would typically be used in RS-232 systems.

To set up an Asynchronous Reception:

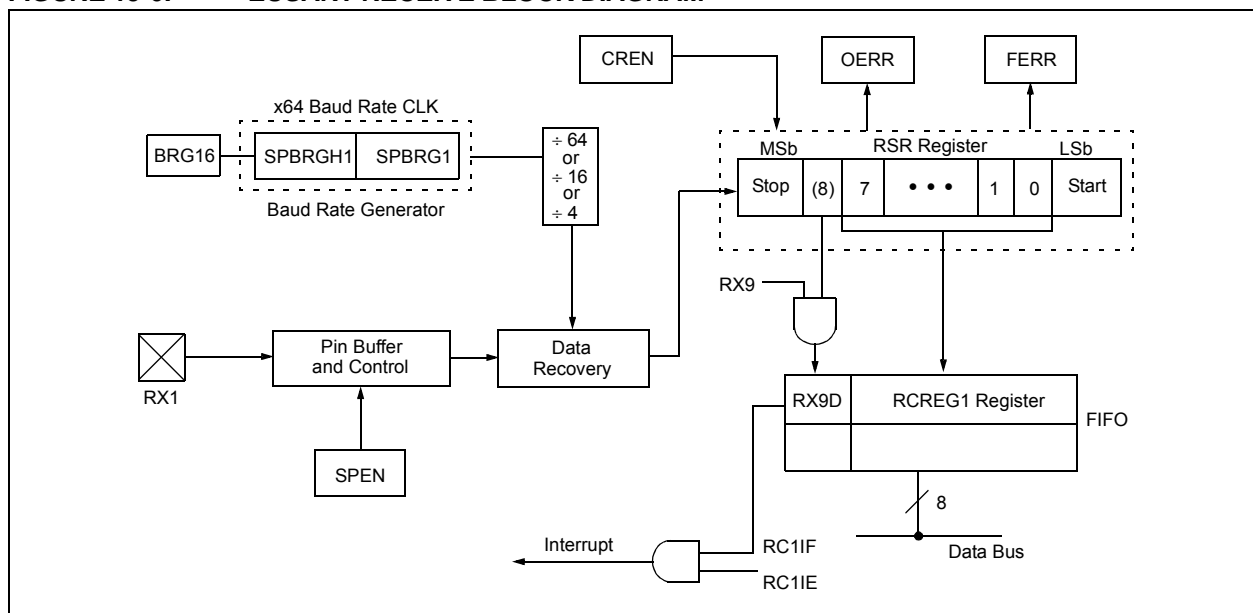
1. Initialize the SPBRGH1:SPBRG1 registers for the appropriate baud rate. Set or clear the BRGH and BRG16 bits, as required, to achieve the desired baud rate.
2. Enable the asynchronous serial port by clearing bit, SYNC, and setting bit, SPEN.
3. If interrupts are desired, set enable bit, RC1IE.
4. If 9-bit reception is desired, set bit, RX9.
5. Enable the reception by setting bit, CREN.
6. Flag bit, RC1IF, will be set when reception is complete and an interrupt will be generated if enable bit, RC1IE, was set.
7. Read the RCSTA1 register to get the 9th bit (if enabled) and determine if any error occurred during reception.
8. Read the 8-bit received data by reading the RCREG1 register.
9. If any error occurred, clear the error by clearing enable bit, CREN.
10. If using interrupts, ensure that the GIE and PEIE bits in the INTCON register (INTCON<7:6>) are set.

## 19.3.3 SETTING UP 9-BIT MODE WITH ADDRESS DETECT

This mode would typically be used in RS-485 systems. To set up an Asynchronous Reception with Address Detect Enable:

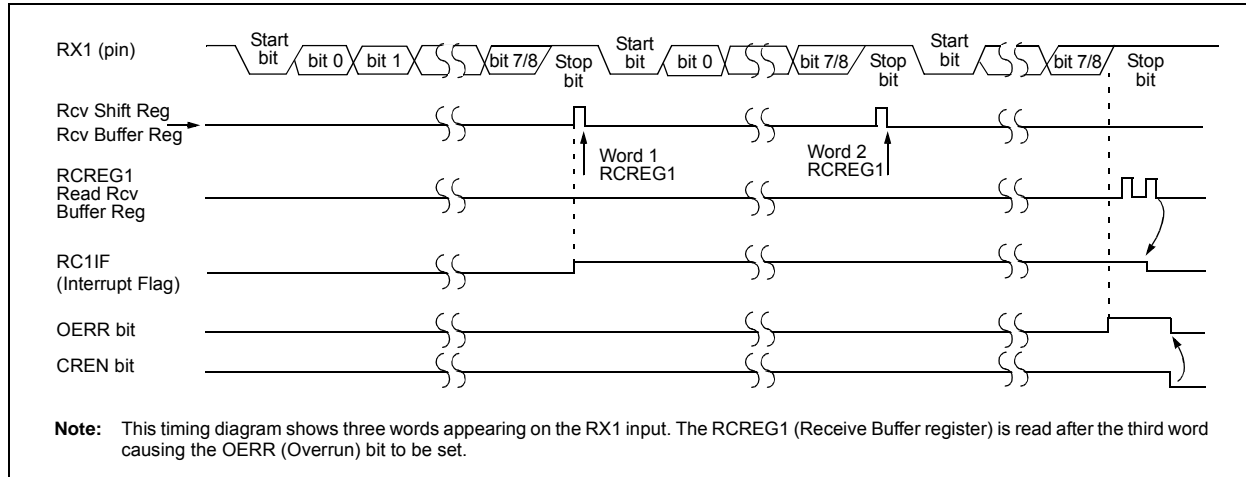
1. Initialize the SPBRGH1:SPBRG1 registers for the appropriate baud rate. Set or clear the BRGH and BRG16 bits, as required, to achieve the desired baud rate.
2. Enable the asynchronous serial port by clearing the SYNC bit and setting the SPEN bit.
3. If interrupts are required, set the RCEN bit and select the desired priority level with the RC1IP bit.
4. Set the RX9 bit to enable 9-bit reception.
5. Set the ADDEN bit to enable address detect.
6. Enable reception by setting the CREN bit.
7. The RC1IF bit will be set when reception is complete. The interrupt will be Acknowledged if the RC1IE and GIE bits are set.
8. Read the RCSTA1 register to determine if any error occurred during reception, as well as read bit 9 of data (if applicable).
9. Read RCREG1 to determine if the device is being addressed.
10. If any error occurred, clear the CREN bit.
11. If the device has been addressed, clear the ADDEN bit to allow all received data into the receive buffer and interrupt the CPU.

**FIGURE 19-6: EUSART RECEIVE BLOCK DIAGRAM**



# PIC18F87J72

**FIGURE 19-7: ASYNCHRONOUS RECEPTION**



**TABLE 19-6: REGISTERS ASSOCIATED WITH ASYNCHRONOUS RECEPTION**

Name	Bit 7	Bit 6	Bit 5	Bit 4	Bit 3	Bit 2	Bit 1	Bit 0	Reset Values on Page
INTCON	GIE/GIEH	PEIE/GIEL	TMR0IE	INT0IE	RBIE	TMR0IF	INT0IF	RBIF	45
PIR1	—	ADIF	RC1IF	TX1IF	SSPIF	—	TMR2IF	TMR1IF	48
PIE1	—	ADIE	RC1IE	TX1IE	SSPIE	—	TMR2IE	TMR1IE	48
IPR1	—	ADIP	RC1IP	TX1IP	SSPIP	—	TMR2IP	TMR1IP	48
RCSTA1	SPEN	RX9	SREN	CREN	ADDEN	FERR	OERR	RX9D	47
RCREG1	EUSART Receive Register								47
TXSTA1	CSRC	TX9	TXEN	SYNC	SENDB	BRGH	TRMT	TX9D	47
BAUDCON1	ABDOVF	RCMT	RXDTP	TXCKP	BRG16	—	WUE	ABDEN	49
SPBRGH1	EUSART Baud Rate Generator Register High Byte								47
SPBRG1	EUSART Baud Rate Generator Register Low Byte								47

Legend: — = unimplemented locations read as '0'. Shaded cells are not used for asynchronous reception.

## 19.3.4 AUTO-WAKE-UP ON SYNC BREAK CHARACTER

During Sleep mode, all clocks to the EUSART are suspended. Because of this, the Baud Rate Generator is inactive and a proper byte reception cannot be performed. The auto-wake-up feature allows the controller to wake-up, due to activity on the RX1/DT1 line, while the EUSART is operating in Asynchronous mode.

The auto-wake-up feature is enabled by setting the WUE bit (BAUDCON<1>). Once set, the typical receive sequence on RX1/DT1 is disabled and the EUSART remains in an Idle state, monitoring for a wake-up event independent of the CPU mode. A wake-up event consists of a high-to-low transition on the RX1/DT1 line. (This coincides with the start of a Sync Break or a Wake-up Signal character for the LIN/J2602 protocol.)

Following a wake-up event, the module generates an RC1IF interrupt. The interrupt is generated synchronously to the Q clocks in normal operating modes (Figure 19-8) and asynchronously, if the device is in Sleep mode (Figure 19-9). The interrupt condition is cleared by reading the RCREG1 register.

The WUE bit is automatically cleared once a low-to-high transition is observed on the RX1 line following the wake-up event. At this point, the EUSART module is in Idle mode and returns to normal operation. This signals to the user that the Sync Break event is over.

### 19.3.4.1 Special Considerations Using Auto-Wake-up

Since auto-wake-up functions by sensing rising edge transitions on RX1/DT1, information with any state changes before the Stop bit may signal a false

End-of-Character (EOC and cause data or framing errors. Therefore, to work properly, the initial character in the transmission must be all '0's. This can be 00h (8 bits) for standard RS-232 devices, or 000h (12 bits) for LIN/J2602 bus.

Oscillator start-up time must also be considered, especially in applications using oscillators with longer start-up intervals (i.e., XT or HS mode). The Sync Break (or Wake-up Signal) character must be of sufficient length and be followed by a sufficient interval to allow enough time for the selected oscillator to start and provide proper initialization of the EUSART.

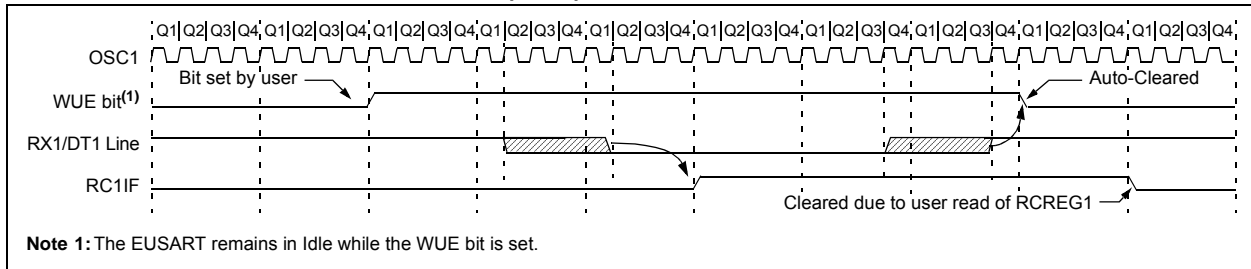
### 19.3.4.2 Special Considerations Using the WUE Bit

The timing of WUE and RC1IF events may cause some confusion when it comes to determining the validity of received data. As noted, setting the WUE bit places the EUSART in an Idle mode. The wake-up event causes a receive interrupt by setting the RC1IF bit. The WUE bit is cleared after this when a rising edge is seen on RX1/DT1. The interrupt condition is then cleared by reading the RCREG1 register. Ordinarily, the data in RCREG1 will be dummy data and should be discarded.

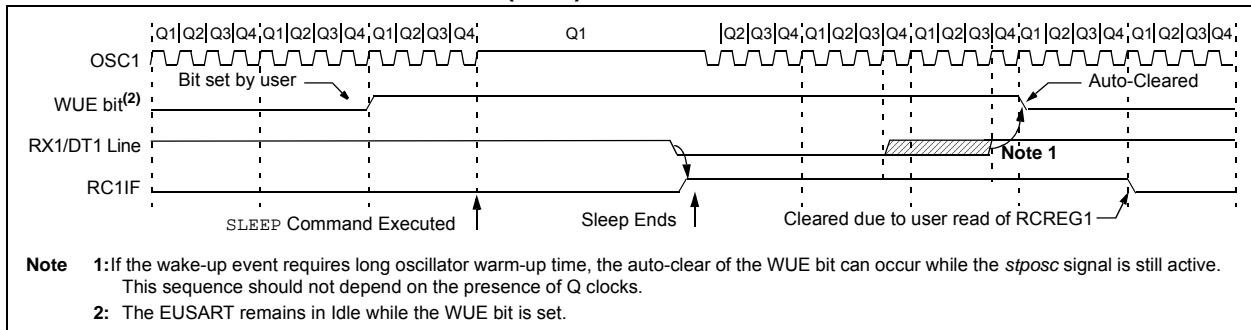
The fact that the WUE bit has been cleared (or is still set) and the RC1IF flag is set should not be used as an indicator of the integrity of the data in RCREG1. Users should consider implementing a parallel method in firmware to verify received data integrity.

To assure that no actual data is lost, check the RCMT bit to verify that a receive operation is not in process. If a receive operation is not occurring, the WUE bit may then be set just prior to entering the Sleep mode.

**FIGURE 19-8: AUTO-WAKE-UP BIT (WUE) TIMINGS DURING NORMAL OPERATION**



**FIGURE 19-9: AUTO-WAKE-UP BIT (WUE) TIMINGS DURING SLEEP**



# PIC18F87J72

## 19.3.5 BREAK CHARACTER SEQUENCE

The Enhanced USART module has the capability of sending the special Break character sequences that are required by the LIN/J2602 bus standard. The Break character transmit consists of a Start bit, followed by twelve '0' bits and a Stop bit. The Frame Break character is sent whenever the SENDB and TXEN bits (TXSTA<3> and TXSTA<5>) are set while the Transmit Shift register is loaded with data. Note that the value of data written to TXREG1 will be ignored and all '0's will be transmitted.

The SENDB bit is automatically reset by hardware after the corresponding Stop bit is sent. This allows the user to preload the transmit FIFO with the next transmit byte following the Break character (typically, the Sync character in the LIN/J2602 specification).

Note that the data value written to the TXREG1 for the Break character is ignored. The write simply serves the purpose of initiating the proper sequence.

The TRMT bit indicates when the transmit operation is active or Idle, just as it does during normal transmission. See [Figure 19-10](#) for the timing of the Break character sequence.

### 19.3.5.1 Break and Sync Transmit Sequence

The following sequence will send a message frame header made up of a Break, followed by an Auto-Baud Sync byte. This sequence is typical of a LIN/J2602 bus master.

1. Configure the EUSART for the desired mode.
2. Set the TXEN and SENDB bits to set up the Break character.

3. Load the TXREG1 with a dummy character to initiate transmission (the value is ignored).
4. Write '55h' to TXREG1 to load the Sync character into the transmit FIFO buffer.
5. After the Break has been sent, the SENDB bit is reset by hardware. The Sync character now transmits in the preconfigured mode.

When the TXREG1 becomes empty, as indicated by the TX1IF, the next data byte can be written to TXREG1.

## 19.3.6 RECEIVING A BREAK CHARACTER

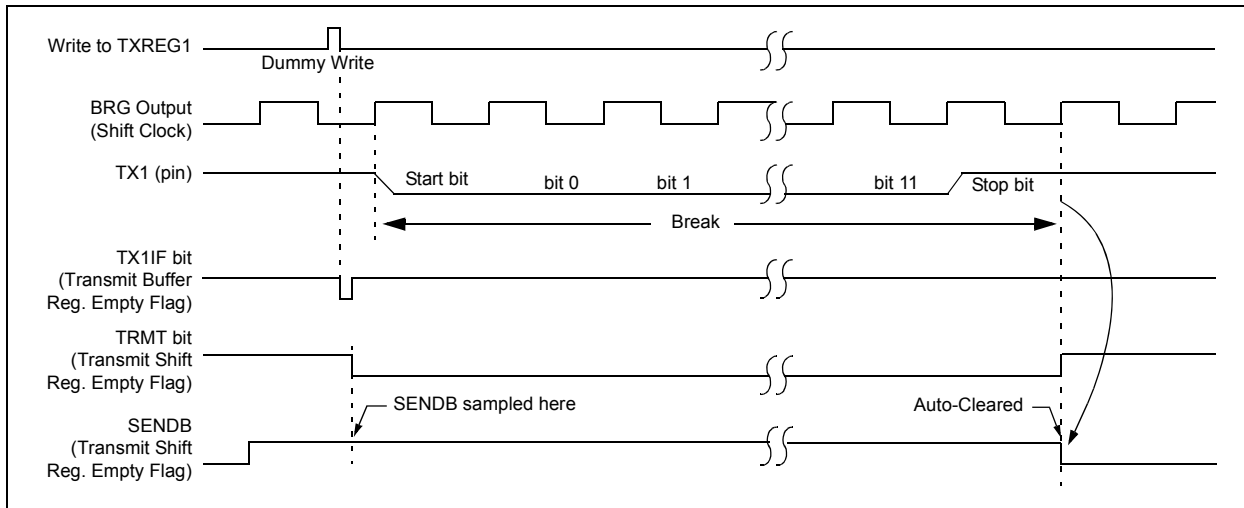
The Enhanced USART module can receive a Break character in two ways.

The first method forces configuration of the baud rate at a frequency of 9/13 the typical speed. This allows for the Stop bit transition to be at the correct sampling location (13 bits for Break versus Start bit and eight data bits for typical data).

The second method uses the auto-wake-up feature described in [Section 19.3.4 "Auto-Wake-up On Sync Break Character"](#). By enabling this feature, the EUSART will sample the next two transitions on RX1/DT1, cause an RC1IF interrupt and receive the next data byte followed by another interrupt.

Note that following a Break character, the user will typically want to enable the Auto-Baud Rate Detect feature. For both methods, the user can set the ABD bit once the TX1IF interrupt is observed.

**FIGURE 19-10: SEND BREAK CHARACTER SEQUENCE**



## 19.4 EUSART Synchronous Master Mode

The Synchronous Master mode is entered by setting the CSRC bit (TXSTA<7>). In this mode, the data is transmitted in a half-duplex manner (i.e., transmission and reception do not occur at the same time). When transmitting data, the reception is inhibited and vice versa. Synchronous mode is entered by setting bit, SYNC (TXSTA<4>). In addition, enable bit, SPEN (RCSTA1<7>), is set in order to configure the TX1 and RX1 pins to CK1 (clock) and DT1 (data) lines, respectively.

The Master mode indicates that the processor transmits the master clock on the CK1 line. Clock polarity is selected with the TXCKP bit (BAUDCON<4>). Setting TXCKP sets the Idle state on CK1 as high, while clearing the bit sets the Idle state as low. This option is provided to support Microwire devices with this module.

### 19.4.1 EUSART SYNCHRONOUS MASTER TRANSMISSION

The EUSART transmitter block diagram is shown in [Figure 19-3](#). The heart of the transmitter is the Transmit (Serial) Shift register (TSR). The Shift register obtains its data from the Read/Write Transmit Buffer register, TXREG1. The TXREG1 register is loaded with data in software. The TSR register is not loaded until the last bit has been transmitted from the previous load. As soon as the last bit is transmitted, the TSR is loaded with new data from the TXREG1 (if available).

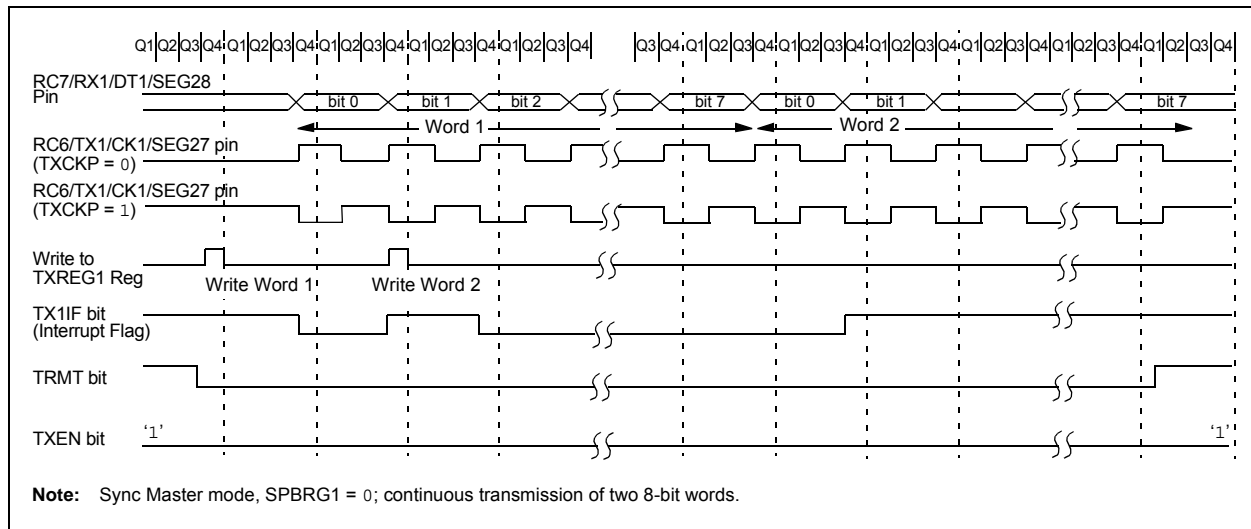
Once the TXREG1 register transfers the data to the TSR register (occurs in one T<sub>CYCLE</sub>), the TXREG1 is empty and the TX1IF flag bit (PIR1<4>) is set. The interrupt can be enabled or disabled by setting or clearing the interrupt enable bit, TX1IE (PIE1<4>). TX1IF is set regardless of the state of enable bit, TX1IE; it cannot be cleared in software. It will reset only when new data is loaded into the TXREG1 register.

While flag bit, TX1IF, indicates the status of the TXREG1 register, another bit, TRMT (TXSTA<1>), shows the status of the TSR register. TRMT is a read-only bit which is set when the TSR is empty. No interrupt logic is tied to this bit so the user has to poll this bit in order to determine if the TSR register is empty. The TSR is not mapped in data memory so it is not available to the user.

To set up a Synchronous Master Transmission:

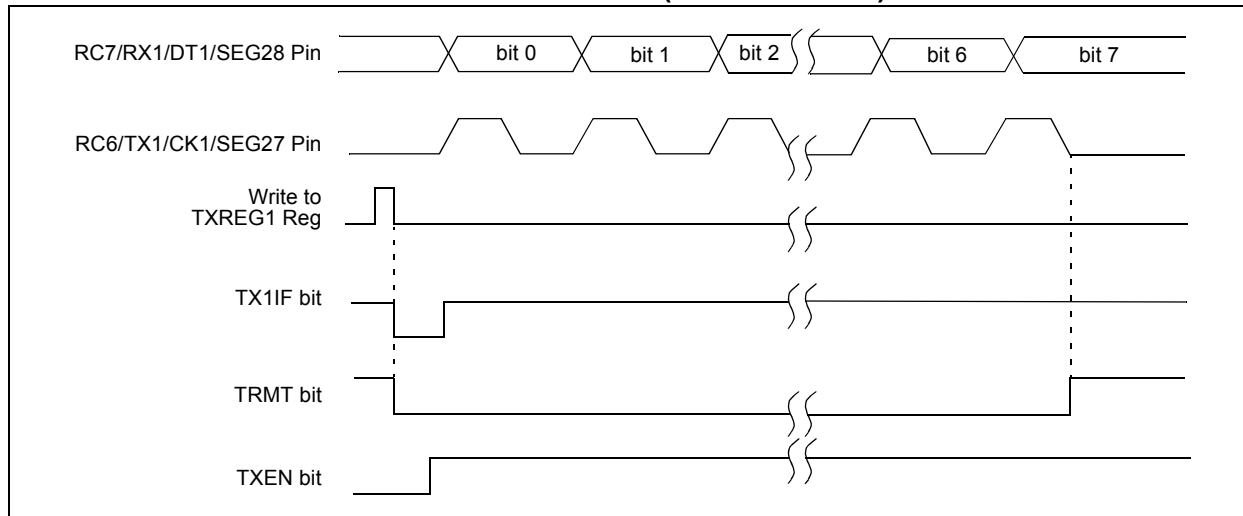
1. Initialize the SPBRGH1:SPBRG1 registers for the appropriate baud rate. Set or clear the BRG16 bit, as required, to achieve the desired baud rate.
2. Enable the synchronous master serial port by setting bits, SYNC, SPEN and CSRC.
3. If interrupts are desired, set enable bit, TX1IE.
4. If 9-bit transmission is desired, set bit, TX9.
5. Enable the transmission by setting bit, TXEN.
6. If 9-bit transmission is selected, the ninth bit should be loaded in bit, TX9D.
7. Start transmission by loading data to the TXREG1 register.
8. If using interrupts, ensure that the GIE and PEIE bits in the INTCON register (INTCON<7:6>) are set.

**FIGURE 19-11: SYNCHRONOUS TRANSMISSION**



# PIC18F87J72

**FIGURE 19-12: SYNCHRONOUS TRANSMISSION (THROUGH TXEN)**



**TABLE 19-7: REGISTERS ASSOCIATED WITH SYNCHRONOUS MASTER TRANSMISSION**

Name	Bit 7	Bit 6	Bit 5	Bit 4	Bit 3	Bit 2	Bit 1	Bit 0	Reset Values on Page
INTCON	GIE/GIEH	PEIE/GIEL	TMR0IE	INT0IE	RBIE	TMR0IF	INT0IF	RBIF	45
PIR1	—	ADIF	RC1IF	TX1IF	SSPIF	—	TMR2IF	TMR1IF	48
PIE1	—	ADIE	RC1IE	TX1IE	SSPIE	—	TMR2IE	TMR1IE	48
IPR1	—	ADIP	RC1IP	TX1IP	SSPIP	—	TMR2IP	TMR1IP	48
RCSTA1	SPEN	RX9	SREN	CREN	ADDEN	FERR	OERR	RX9D	47
TXREG1	EUSART Transmit Register								47
TXSTA1	CSRC	TX9	TXEN	SYNC	SENDB	BRGH	TRMT	TX9D	47
BAUDCON1	ABDOVF	RCMT	RXDTP	TXCKP	BRG16	—	WUE	ABDEN	49
SPBRGH1	EUSART Baud Rate Generator Register High Byte								49
SPBRG1	EUSART Baud Rate Generator Register Low Byte								47
LATG	U2OD	U1OD	—	LATG4	LATG3	LATG2	LATG1	LATG0	48

Legend: — = unimplemented, read as '0'. Shaded cells are not used for synchronous master transmission.



## 19.4.2 EUSART SYNCHRONOUS MASTER RECEPTION

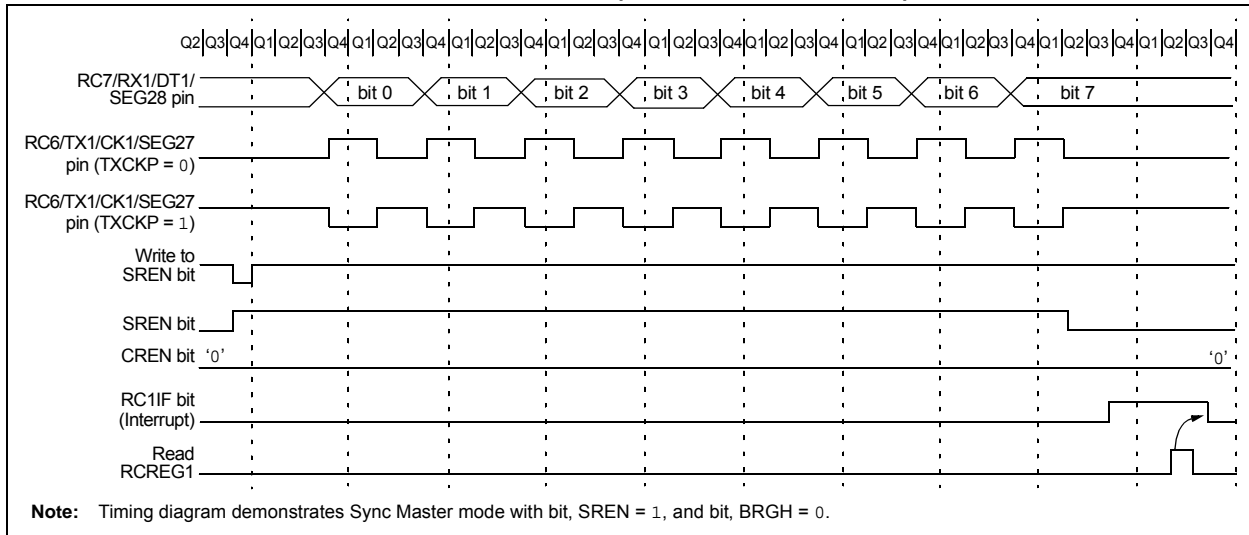
Once Synchronous mode is selected, reception is enabled by setting either the Single Receive Enable bit, SREN (RCSTA1<5>), or the Continuous Receive Enable bit, CREN (RCSTA1<4>). Data is sampled on the RX1 pin on the falling edge of the clock.

If enable bit, SREN, is set, only a single word is received. If enable bit, CREN, is set, the reception is continuous until CREN is cleared. If both bits are set, then CREN takes precedence.

To set up a Synchronous Master Reception:

1. Initialize the SPBRGH1:SPBRG1 registers for the appropriate baud rate. Set or clear the BRG16 bit, as required, to achieve the desired baud rate.
2. Enable the synchronous master serial port by setting bits, SYNC, SPEN and CSRC.
3. Ensure bits, CREN and SREN, are clear.
4. If interrupts are desired, set enable bit, RC1IE.
5. If 9-bit reception is desired, set bit, RX9.
6. If a single reception is required, set bit, SREN. For continuous reception, set bit, CREN.
7. Interrupt flag bit, RC1IF, will be set when reception is complete and an interrupt will be generated if the enable bit, RC1IE, was set.
8. Read the RCSTA1 register to get the 9th bit (if enabled) and determine if any error occurred during reception.
9. Read the 8-bit received data by reading the RCREG1 register.
10. If any error occurred, clear the error by clearing bit, CREN.
11. If using interrupts, ensure that the GIE and PEIE bits in the INTCON register (INTCON<7:6>) are set.

**FIGURE 19-13: SYNCHRONOUS RECEPTION (MASTER MODE, SREN)**



**TABLE 19-8: REGISTERS ASSOCIATED WITH SYNCHRONOUS MASTER RECEPTION**

Name	Bit 7	Bit 6	Bit 5	Bit 4	Bit 3	Bit 2	Bit 1	Bit 0	Reset Values on Page
INTCON	GIE/GIEH	PEIE/GIEL	TMR0IE	INT0IE	RBIE	TMR0IF	INT0IF	RBIF	45
PIR1	—	ADIF	RC1IF	TX1IF	SSPIF	—	TMR2IF	TMR1IF	48
PIE1	—	ADIE	RC1IE	TX1IE	SSPIE	—	TMR2IE	TMR1IE	48
IPR1	—	ADIP	RC1IP	TX1IP	SSPIP	—	TMR2IP	TMR1IP	48
RCSTA1	SPEN	RX9	SREN	CREN	ADDEN	FERR	OERR	RX9D	47
RCREG1	EUSART Receive Register								47
TXSTA1	CSRC	TX9	TXEN	SYNC	SENDB	BRGH	TRMT	TX9D	47
BAUDCON1	ABDOVF	RCMT	RXDTP	TXCKP	BRG16	—	WUE	ABDEN	49
SPBRGH1	EUSART Baud Rate Generator Register High Byte								49
SPBRG1	EUSART Baud Rate Generator Register Low Byte								47

Legend: — = unimplemented, read as '0'. Shaded cells are not used for synchronous master reception.

# PIC18F87J72

## 19.5 EUSART Synchronous Slave Mode

Synchronous Slave mode is entered by clearing bit, CSRC (TXSTA<7>). This mode differs from the Synchronous Master mode in that the shift clock is supplied externally at the CK1 pin (instead of being supplied internally in Master mode). This allows the device to transfer or receive data while in any low-power mode.

### 19.5.1 EUSART SYNCHRONOUS SLAVE TRANSMIT

The operation of the Synchronous Master and Slave modes are identical except in the case of Sleep mode.

If two words are written to the TXREG1 and then the SLEEP instruction is executed, the following will occur:

- a) The first word will immediately transfer to the TSR register and transmit.
- b) The second word will remain in the TXREG1 register.
- c) Flag bit, TX1IF, will not be set.
- d) When the first word has been shifted out of TSR, the TXREG1 register will transfer the second word to the TSR and flag bit, TX1IF, will now be set.
- e) If enable bit, TX1IE, is set, the interrupt will wake the chip from Sleep. If the global interrupt is enabled, the program will branch to the interrupt vector.

To set up a Synchronous Slave Transmission:

1. Enable the synchronous slave serial port by setting bits, SYNC and SPEN, and clearing bit, CSRC.
2. Clear bits, CREN and SREN.
3. If interrupts are desired, set enable bit, TX1IE.
4. If 9-bit transmission is desired, set bit, TX9.
5. Enable the transmission by setting enable bit, TXEN.
6. If 9-bit transmission is selected, the ninth bit should be loaded in bit, TX9D.
7. Start transmission by loading data to the TXREG1 register.
8. If using interrupts, ensure that the GIE and PEIE bits in the INTCON register (INTCON<7:6>) are set.

**TABLE 19-9: REGISTERS ASSOCIATED WITH SYNCHRONOUS SLAVE TRANSMISSION**

Name	Bit 7	Bit 6	Bit 5	Bit 4	Bit 3	Bit 2	Bit 1	Bit 0	Reset Values on Page
INTCON	GIE/GIEH	PEIE/GIEL	TMR0IE	INT0IE	RBIE	TMR0IF	INT0IF	RBIF	45
PIR1	—	ADIF	RC1IF	TX1IF	SSPIF	—	TMR2IF	TMR1IF	48
PIE1	—	ADIE	RC1IE	TX1IE	SSPIE	—	TMR2IE	TMR1IE	48
IPR1	—	ADIP	RC1IP	TX1IP	SSPIP	—	TMR2IP	TMR1IP	48
RCSTA1	SPEN	RX9	SREN	CREN	ADDEN	FERR	OERR	RX9D	47
TXREG1	EUSART Transmit Register								47
TXSTA1	CSRC	TX9	TXEN	SYNC	SENDB	BRGH	TRMT	TX9D	47
BAUDCON1	ABDOVF	RCMT	RXDTP	TXCKP	BRG16	—	WUE	ABDEN	49
SPBRGH1	EUSART Baud Rate Generator Register High Byte								49
SPBRG1	EUSART Baud Rate Generator Register Low Byte								47
LATG	U2OD	U1OD	—	LATG4	LATG3	LATG2	LATG1	LATG0	48

Legend: — = unimplemented, read as '0'. Shaded cells are not used for synchronous slave transmission.

## 19.5.2 EUSART SYNCHRONOUS SLAVE RECEPTION

The operation of the Synchronous Master and Slave modes is identical except in the case of Sleep or any Idle mode, and bit, SREN, which is a “don’t care” in Slave mode.

If receive is enabled by setting the CREN bit prior to entering Sleep or any Idle mode, then a word may be received while in this low-power mode. Once the word is received, the RSR register will transfer the data to the RCREG1 register; if the RC1IE enable bit is set, the interrupt generated will wake the chip from the low-power mode. If the global interrupt is enabled, the program will branch to the interrupt vector.

To set up a Synchronous Slave Reception:

1. Enable the synchronous master serial port by setting bits, SYNC and SPEN, and clearing bit, CSRC.
2. If interrupts are desired, set enable bit, RC1IE.
3. If 9-bit reception is desired, set bit, RX9.
4. To enable reception, set enable bit, CREN.
5. Flag bit, RC1IF, will be set when reception is complete. An interrupt will be generated if enable bit, RC1IE, was set.
6. Read the RCSTA1 register to get the 9th bit (if enabled) and determine if any error occurred during reception.
7. Read the 8-bit received data by reading the RCREG1 register.
8. If any error occurred, clear the error by clearing bit, CREN.
9. If using interrupts, ensure that the GIE and PEIE bits in the INTCON register (INTCON<7:6>) are set.

**TABLE 19-10: REGISTERS ASSOCIATED WITH SYNCHRONOUS SLAVE RECEPTION**

Name	Bit 7	Bit 6	Bit 5	Bit 4	Bit 3	Bit 2	Bit 1	Bit 0	Reset Values on Page
INTCON	GIE/GIEH	PEIE/GIEL	TMR0IE	INT0IE	RBIE	TMR0IF	INT0IF	RBIF	45
PIR1	—	ADIF	RC1IF	TX1IF	SSPIF	—	TMR2IF	TMR1IF	48
PIE1	—	ADIE	RC1IE	TX1IE	SSPIE	—	TMR2IE	TMR1IE	48
IPR1	—	ADIP	RC1IP	TX1IP	SSPIP	—	TMR2IP	TMR1IP	48
RCSTA1	SPEN	RX9	SREN	CREN	ADDEN	FERR	OERR	RX9D	47
RCREG1	EUSART Receive Register								47
TXSTA1	CSRC	TX9	TXEN	SYNC	SENDB	BRGH	TRMT	TX9D	47
BAUDCON1	ABDOVF	RCMT	RXDTP	TXCKP	BRG16	—	WUE	ABDEN	49
SPBRGH1	EUSART Baud Rate Generator Register High Byte								49
SPBRG1	EUSART Baud Rate Generator Register Low Byte								47

Legend: — = unimplemented, read as '0'. Shaded cells are not used for synchronous slave reception.

## 20.0 ADDRESSABLE UNIVERSAL SYNCHRONOUS ASYNCHRONOUS RECEIVER TRANSMITTER (AUSART)

The Addressable Universal Synchronous Asynchronous Receiver Transmitter (AUSART) module is very similar in function to the Enhanced USART module, discussed in the previous chapter. It is provided as an additional channel for serial communication with external devices, for those situations that do not require auto-baud detection or LIN/J2602 bus support.

The AUSART can be configured in the following modes:

- Asynchronous (full-duplex)
- Synchronous – Master (half-duplex)
- Synchronous – Slave (half-duplex)

The pins of the AUSART module are multiplexed with the functions of PORTG (RG1/TX2/CK2 and RG2/RX2/DT2/VLCAP1, respectively). In order to configure these pins as an AUSART:

- PEN bit (RCSTA2<7>) must be set (= 1)
- TXEN bit (TXSTA2<5>) must also be set (= 1) to configure TX2/CK2 to transmit
- TRISG<2> bit must be set (= 1)
- TRISG<1> bit must be cleared (= 0) for Asynchronous and Synchronous Master modes
- TRISG<1> bit must be set (= 1) for Synchronous Slave mode

<b>Note:</b> The AUSART control will automatically reconfigure the pin from input to output as needed.
--

The driver for the TX2 output pin can also be optionally configured as an open-drain output. This feature allows the voltage level on the pin to be pulled to a higher level through an external pull-up resistor and allows the output to communicate with external circuits without the need for additional level shifters.

The open-drain output option is controlled by the U2OD bit (LATG<7>). Setting the bit configures the pin for open-drain operation.

### 20.1 Control Registers

The operation of the Addressable USART module is controlled through two registers: TXSTA2 and RXSTA2. These are detailed in [Register 20-1](#) and [Register 20-2](#), respectively.

## REGISTER 20-1: TXSTA2: AUSART TRANSMIT STATUS AND CONTROL REGISTER

R/W-0	R/W-0	R/W-0	R/W-0	U-0	R/W-0	R-1	R/W-0
CSRC	TX9	TXEN <sup>(1)</sup>	SYNC	—	BRGH	TRMT	TX9D
bit 7							bit 0

**Legend:**

R = Readable bit	W = Writable bit	U = Unimplemented bit, read as '0'
-n = Value at POR	'1' = Bit is set	'0' = Bit is cleared
		x = Bit is unknown

- bit 7      **CSRC:** Clock Source Select bit  
Asynchronous mode:  
 Don't care.  
Synchronous mode:  
 1 = Master mode (clock generated internally from BRG)  
 0 = Slave mode (clock from external source)
- bit 6      **TX9:** 9-Bit Transmit Enable bit  
 1 = Selects 9-bit transmission  
 0 = Selects 8-bit transmission
- bit 5      **TXEN:** Transmit Enable bit<sup>(1)</sup>  
 1 = Transmit enabled  
 0 = Transmit disabled
- bit 4      **SYNC:** AUSART Mode Select bit  
 1 = Synchronous mode  
 0 = Asynchronous mode
- bit 3      **Unimplemented:** Read as '0'
- bit 2      **BRGH:** High Baud Rate Select bit  
Asynchronous mode:  
 1 = High speed  
 0 = Low speed  
Synchronous mode:  
 Unused in this mode.
- bit 1      **TRMT:** Transmit Shift Register Status bit  
 1 = TSR empty  
 0 = TSR full
- bit 0      **TX9D:** 9th bit of Transmit Data  
 Can be address/data bit or a parity bit.

**Note 1:** SREN/CREN overrides TXEN in Sync mode.

# PIC18F87J72

## REGISTER 20-2: RCSTA2: AUSART RECEIVE STATUS AND CONTROL REGISTER

R/W-0	R/W-0	R/W-0	R/W-0	R/W-0	R-0	R-0	R-x
SPEN	RX9	SREN	CREN	ADDEN	FERR	OERR	RX9D
bit 7							bit 0

### Legend:

R = Readable bit	W = Writable bit	U = Unimplemented bit, read as '0'
-n = Value at POR	'1' = Bit is set	'0' = Bit is cleared
		x = Bit is unknown

- bit 7      **SPEN:** Serial Port Enable bit  
 1 = Serial port enabled (configures RX2/DT2 and TX2/CK2 pins as serial port pins; TXEN must also be set to configure TX2/CK2 to transmit)  
 0 = Serial port disabled (held in Reset)
- bit 6      **RX9:** 9-Bit Receive Enable bit  
 1 = Selects 9-bit reception  
 0 = Selects 8-bit reception
- bit 5      **SREN:** Single Receive Enable bit  
Asynchronous mode:  
 Don't care.  
Synchronous mode – Master:  
 1 = Enables single receive  
 0 = Disables single receive  
 This bit is cleared after reception is complete.  
Synchronous mode – Slave:  
 Don't care.
- bit 4      **CREN:** Continuous Receive Enable bit  
Asynchronous mode:  
 1 = Enables receiver  
 0 = Disables receiver  
Synchronous mode:  
 1 = Enables continuous receive until enable bit, CREN, is cleared (CREN overrides SREN)  
 0 = Disables continuous receive
- bit 3      **ADDEN:** Address Detect Enable bit  
Asynchronous mode 9-bit (RX9 = 1):  
 1 = Enables address detection, enables interrupt and loads the receive buffer when RSR<8> is set  
 0 = Disables address detection, all bytes are received and ninth bit can be used as parity bit  
Asynchronous mode 9-bit (RX9 = 0):  
 Don't care.
- bit 2      **FERR:** Framing Error bit  
 1 = Framing error (can be cleared by reading RCREG2 register and receiving next valid byte)  
 0 = No framing error
- bit 1      **OERR:** Overrun Error bit  
 1 = Overrun error (can be cleared by clearing bit CREN)  
 0 = No overrun error
- bit 0      **RX9D:** 9th bit of Received Data  
 This can be an address/data bit or a parity bit and must be calculated by user firmware.

## 20.2 AUSART Baud Rate Generator (BRG)

The BRG is a dedicated, 8-bit generator that supports both the Asynchronous and Synchronous modes of the AUSART.

The SPBRG2 register controls the period of a free-running timer. In Asynchronous mode, the BRGH (TXSTA<2>) bit also controls the baud rate. In Synchronous mode, BRGH is ignored. [Table 20-1](#) shows the formula for computation of the baud rate for different AUSART modes, which only apply in Master mode (internally generated clock).

Given the desired baud rate and FOSC, the nearest integer value for the SPBRG2 register can be calculated using the formulas in [Table 20-1](#). From this, the error in baud rate can be determined. An example calculation is shown in [Example 20-1](#). Typical baud rates and error values for the various Asynchronous modes are shown in [Table 20-3](#). It may be advantageous to use the high baud rate (BRGH = 1) to reduce the baud rate error, or achieve a slow baud rate for a fast oscillator frequency.

Writing a new value to the SPBRG2 register causes the BRG timer to be reset (or cleared). This ensures the BRG does not wait for a timer overflow before outputting the new baud rate.

### 20.2.1 OPERATION IN POWER-MANAGED MODES

The device clock is used to generate the desired baud rate. When one of the power-managed modes is entered, the new clock source may be operating at a different frequency. This may require an adjustment to the value in the SPBRG2 register.

### 20.2.2 SAMPLING

The data on the RX2 pin is sampled three times by a majority detect circuit to determine if a high or a low level is present on the RX2 pin.

**TABLE 20-1: BAUD RATE FORMULAS**

Configuration Bits		BRG/AUSART Mode	Baud Rate Formula
SYNC	BRGH		
0	0	Asynchronous	$F_{OSC}/[64 (n + 1)]$
0	1	Asynchronous	$F_{OSC}/[16 (n + 1)]$
1	x	Synchronous	$F_{OSC}/[4 (n + 1)]$

Legend: x = Don't care, n = Value of SPBRG2 register

### EXAMPLE 20-1: CALCULATING BAUD RATE ERROR

<p>For a device with FOSC of 16 MHz, desired baud rate of 9600, Asynchronous mode, BRGH = 0:  Desired Baud Rate = <math>F_{OSC}/(64 ([SPBRG2] + 1))</math>  Solving for SPBRG2:  <math display="block">X = ((F_{OSC}/\text{Desired Baud Rate})/64) - 1</math> <math display="block">= ((16000000/9600)/64) - 1</math> <math display="block">= [25.042] = 25</math> Calculated Baud Rate = <math>16000000/(64 (25 + 1))</math>  <math display="block">= 9615</math> Error = <math>(\text{Calculated Baud Rate} - \text{Desired Baud Rate})/\text{Desired Baud Rate}</math>  <math display="block">= (9615 - 9600)/9600 = 0.16\%</math></p>
---

**TABLE 20-2: REGISTERS ASSOCIATED WITH THE BAUD RATE GENERATOR**

Name	Bit 7	Bit 6	Bit 5	Bit 4	Bit 3	Bit 2	Bit 1	Bit 0	Reset Values on Page
TXSTA2	CSRC	TX9	TXEN	SYNC	—	BRGH	TRMT	TX9D	50
RCSTA2	SPEN	RX9	SREN	CREN	ADDEN	FERR	OERR	RX9D	50
SPBRG2	AUSART Baud Rate Generator Register								50

Legend: Shaded cells are not used by the BRG.

# PIC18F87J72

**TABLE 20-3: BAUD RATES FOR ASYNCHRONOUS MODES**

BAUD RATE (K)	BRGH = 0											
	Fosc = 40.000 MHz			Fosc = 20.000 MHz			Fosc = 10.000 MHz			Fosc = 8.000 MHz		
	Actual Rate (K)	% Error	SPBRG value (decimal)	Actual Rate (K)	% Error	SPBRG value (decimal)	Actual Rate (K)	% Error	SPBRG value (decimal)	Actual Rate (K)	% Error	SPBRG value (decimal)
0.3	—	—	—	—	—	—	—	—	—	—	—	—
1.2	—	—	—	1.221	1.73	255	1.202	0.16	129	1.201	-0.16	103
2.4	2.441	1.73	255	2.404	0.16	129	2.404	0.16	64	2.403	-0.16	51
9.6	9.615	0.16	64	9.766	1.73	31	9.766	1.73	15	9.615	-0.16	12
19.2	19.531	1.73	31	19.531	1.73	15	19.531	1.73	7	—	—	—
57.6	56.818	-1.36	10	62.500	8.51	4	52.083	-9.58	2	—	—	—
115.2	125.000	8.51	4	104.167	-9.58	2	78.125	-32.18	1	—	—	—

BAUD RATE (K)	BRGH = 0								
	Fosc = 4.000 MHz			Fosc = 2.000 MHz			Fosc = 1.000 MHz		
	Actual Rate (K)	% Error	SPBRG value (decimal)	Actual Rate (K)	% Error	SPBRG value (decimal)	Actual Rate (K)	% Error	SPBRG value (decimal)
0.3	0.300	0.16	207	0.300	-0.16	103	0.300	-0.16	51
1.2	1.202	0.16	51	1.201	-0.16	25	1.201	-0.16	12
2.4	2.404	0.16	25	2.403	-0.16	12	—	—	—
9.6	8.929	-6.99	6	—	—	—	—	—	—
19.2	20.833	8.51	2	—	—	—	—	—	—
57.6	62.500	8.51	0	—	—	—	—	—	—
115.2	62.500	-45.75	0	—	—	—	—	—	—

BAUD RATE (K)	BRGH = 1											
	Fosc = 40.000 MHz			Fosc = 20.000 MHz			Fosc = 10.000 MHz			Fosc = 8.000 MHz		
	Actual Rate (K)	% Error	SPBRG value (decimal)	Actual Rate (K)	% Error	SPBRG value (decimal)	Actual Rate (K)	% Error	SPBRG value (decimal)	Actual Rate (K)	% Error	SPBRG value (decimal)
0.3	—	—	—	—	—	—	—	—	—	—	—	—
1.2	—	—	—	—	—	—	—	—	—	—	—	—
2.4	—	—	—	—	—	—	2.441	1.73	255	2.403	-0.16	207
9.6	9.766	1.73	255	9.615	0.16	129	9.615	0.16	64	9.615	-0.16	51
19.2	19.231	0.16	129	19.231	0.16	64	19.531	1.73	31	19.230	-0.16	25
57.6	58.140	0.94	42	56.818	-1.36	21	56.818	-1.36	10	55.555	3.55	8
115.2	113.636	-1.36	21	113.636	-1.36	10	125.000	8.51	4	—	—	—

BAUD RATE (K)	BRGH = 1								
	Fosc = 4.000 MHz			Fosc = 2.000 MHz			Fosc = 1.000 MHz		
	Actual Rate (K)	% Error	SPBRG value (decimal)	Actual Rate (K)	% Error	SPBRG value (decimal)	Actual Rate (K)	% Error	SPBRG value (decimal)
0.3	—	—	—	—	—	—	0.300	-0.16	207
1.2	1.202	0.16	207	1.201	-0.16	103	1.201	-0.16	51
2.4	2.404	0.16	103	2.403	-0.16	51	2.403	-0.16	25
9.6	9.615	0.16	25	9.615	-0.16	12	—	—	—
19.2	19.231	0.16	12	—	—	—	—	—	—
57.6	62.500	8.51	3	—	—	—	—	—	—
115.2	125.000	8.51	1	—	—	—	—	—	—



## 20.3 AUSART Asynchronous Mode

The Asynchronous mode of operation is selected by clearing the SYNC bit (TXSTA2<4>). In this mode, the AUSART uses standard Non-Return-to-Zero (NRZ) format (one Start bit, eight or nine data bits and one Stop bit). The most common data format is eight bits. An on-chip, dedicated, 8-bit Baud Rate Generator can be used to derive standard baud rate frequencies from the oscillator.

The AUSART transmits and receives the LSb first. The AUSART's transmitter and receiver are functionally independent but use the same data format and baud rate. The Baud Rate Generator produces a clock, either x16 or x64 of the bit shift rate, depending on the BRGH bit (TXSTA2<2>). Parity is not supported by the hardware but can be implemented in software and stored as the 9th data bit.

When operating in Asynchronous mode, the AUSART module consists of the following important elements:

- Baud Rate Generator
- Sampling Circuit
- Asynchronous Transmitter
- Asynchronous Receiver

### 20.3.1 AUSART ASYNCHRONOUS TRANSMITTER

The AUSART transmitter block diagram is shown in Figure 20-1. The heart of the transmitter is the Transmit (Serial) Shift register (TSR). The Shift register obtains its data from the Read/Write Transmit Buffer register, TXREG2. The TXREG2 register is loaded with data in software. The TSR register is not loaded until the Stop bit has been transmitted from the previous load. As soon as the Stop bit is transmitted, the TSR is loaded with new data from the TXREG2 register (if available).

Once the TXREG2 register transfers the data to the TSR register (occurs in one T<sub>cy</sub>), the TXREG2 register is empty and the TX2IF flag bit (PIR3<4>) is set. This interrupt can be enabled or disabled by setting or clearing the interrupt enable bit, TX2IE (PIE3<4>). TX2IF will be set regardless of the state of TX2IE; it cannot be cleared in software. TX2IF is also not cleared immediately upon loading TXREG2, but becomes valid in the second instruction cycle following the load instruction. Polling TX2IF immediately following a load of TXREG2 will return invalid results.

While TX2IF indicates the status of the TXREG2 register, another bit, TRMT (TXSTA2<1>), shows the status of the TSR register. TRMT is a read-only bit which is set when the TSR register is empty. No interrupt logic is tied to this bit so the user has to poll this bit in order to determine if the TSR register is empty.

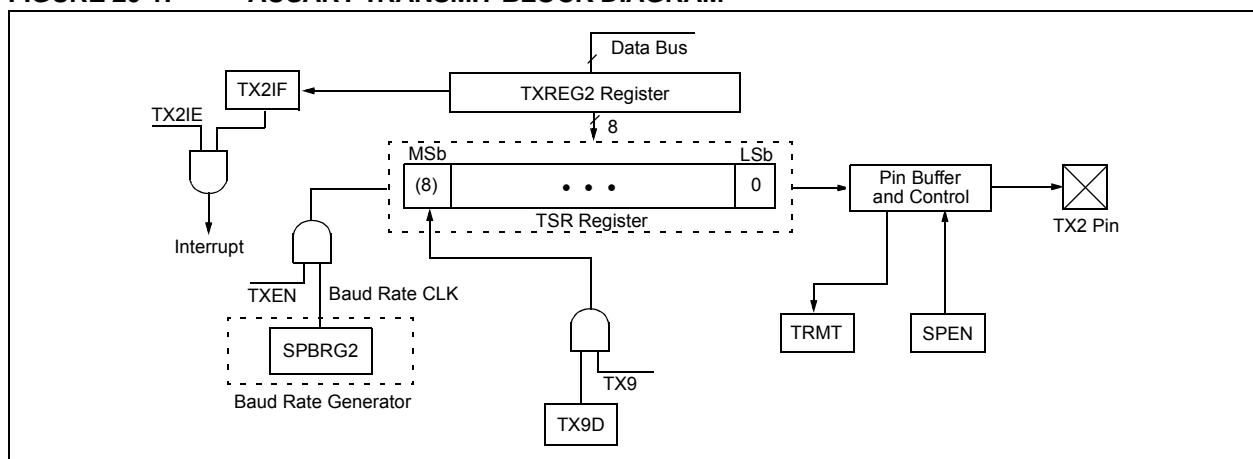
**Note 1:** The TSR register is not mapped in data memory so it is not available to the user.

**2:** Flag bit, TX2IF, is set when enable bit, TXEN, is set.

To set up an Asynchronous Transmission:

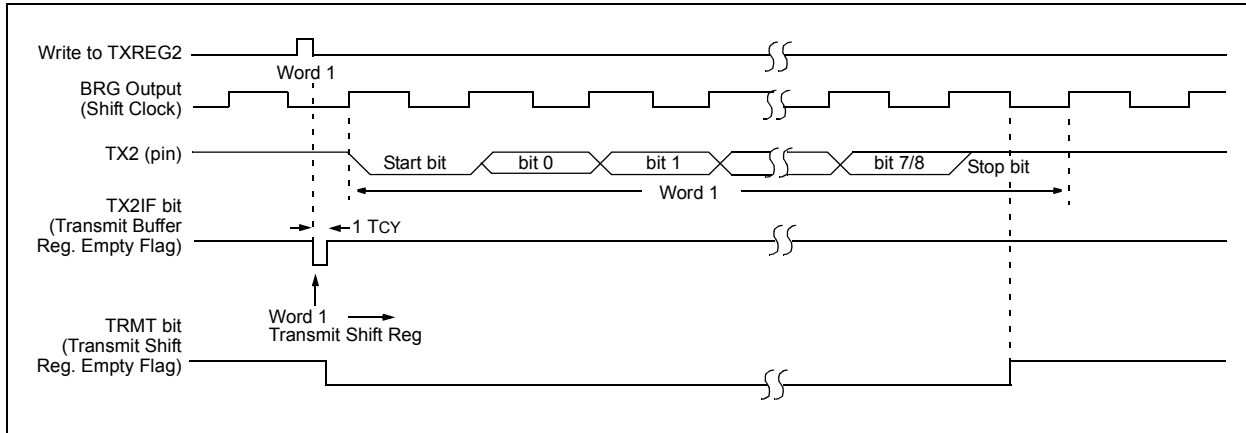
1. Initialize the SPBRG2 register for the appropriate baud rate. Set or clear the BRGH bit, as required, to achieve the desired baud rate.
2. Enable the asynchronous serial port by clearing bit, SYNC, and setting bit, SPEN.
3. If interrupts are desired, set enable bit, TX2IE.
4. If 9-bit transmission is desired, set transmit bit, TX9. Can be used as address/data bit.
5. Enable the transmission by setting bit, TXEN, which will also set bit, TX2IF.
6. If 9-bit transmission is selected, the ninth bit should be loaded in bit, TX9D.
7. Load data to the TXREG2 register (starts transmission).
8. If using interrupts, ensure that the GIE and PEIE bits in the INTCON register (INTCON<7:6>) are set.

**FIGURE 20-1: AUSART TRANSMIT BLOCK DIAGRAM**

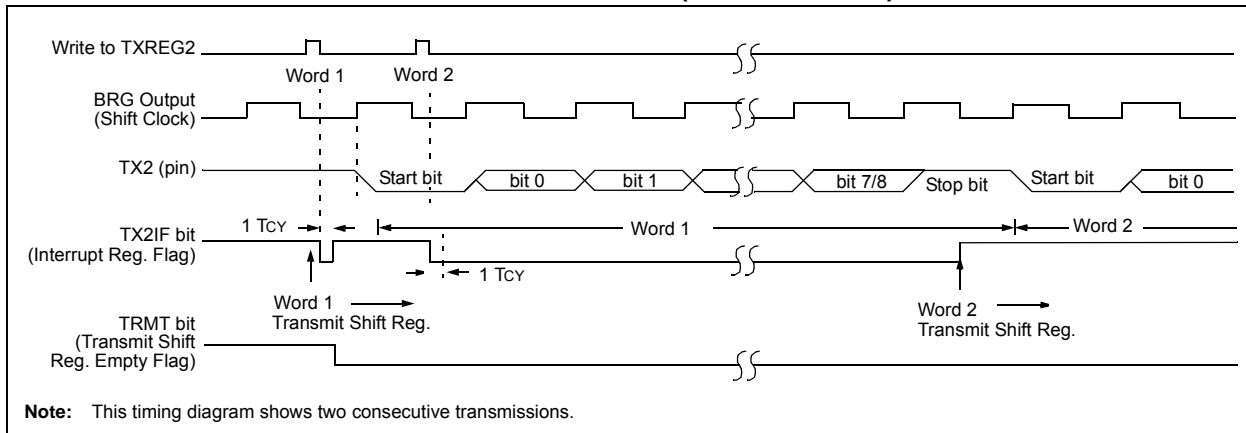


# PIC18F87J72

**FIGURE 20-2: ASYNCHRONOUS TRANSMISSION**



**FIGURE 20-3: ASYNCHRONOUS TRANSMISSION (BACK TO BACK)**



**TABLE 20-4: REGISTERS ASSOCIATED WITH ASYNCHRONOUS TRANSMISSION**

Name	Bit 7	Bit 6	Bit 5	Bit 4	Bit 3	Bit 2	Bit 1	Bit 0	Reset Values on Page
INTCON	GIE/GIEH	PEIE/GIEL	TMR0IE	INT0IE	RBIE	TMR0IF	INT0IF	RBIF	45
PIR3	—	LCDIF	RC2IF	TX2IF	CTMUIF	CCP2IF	CCP1IF	RTCCIF	48
PIE3	—	LCDIE	RC2IE	TX2IE	CTMUIE	CCP2IE	CCP1IE	RTCCIE	48
IPR3	—	LCDIP	RC2IP	TX2IP	CTMUIP	CCP2IP	CCP1IP	RTCCIP	48
RCSTA2	SPEN	RX9	SREN	CREN	ADDEN	FERR	OERR	RX9D	50
TXREG2	AUSART Transmit Register								50
TXSTA2	CSRC	TX9	TXEN	SYNC	—	BRGH	TRMT	TX9D	50
SPBRG2	AUSART Baud Rate Generator Register								50
LATG	U2OD	U1OD	—	LATG4	LATG3	LATG2	LATG1	LATG0	48

Legend: — = unimplemented locations read as '0'. Shaded cells are not used for asynchronous transmission.

## 20.3.2 AUSART ASYNCHRONOUS RECEIVER

The receiver block diagram is shown in [Figure 20-4](#). The data is received on the RX2 pin and drives the data recovery block. The data recovery block is actually a high-speed shifter operating at x16 times the baud rate, whereas the main receive serial shifter operates at the bit rate or at Fosc. This mode would typically be used in RS-232 systems.

To set up an Asynchronous Reception:

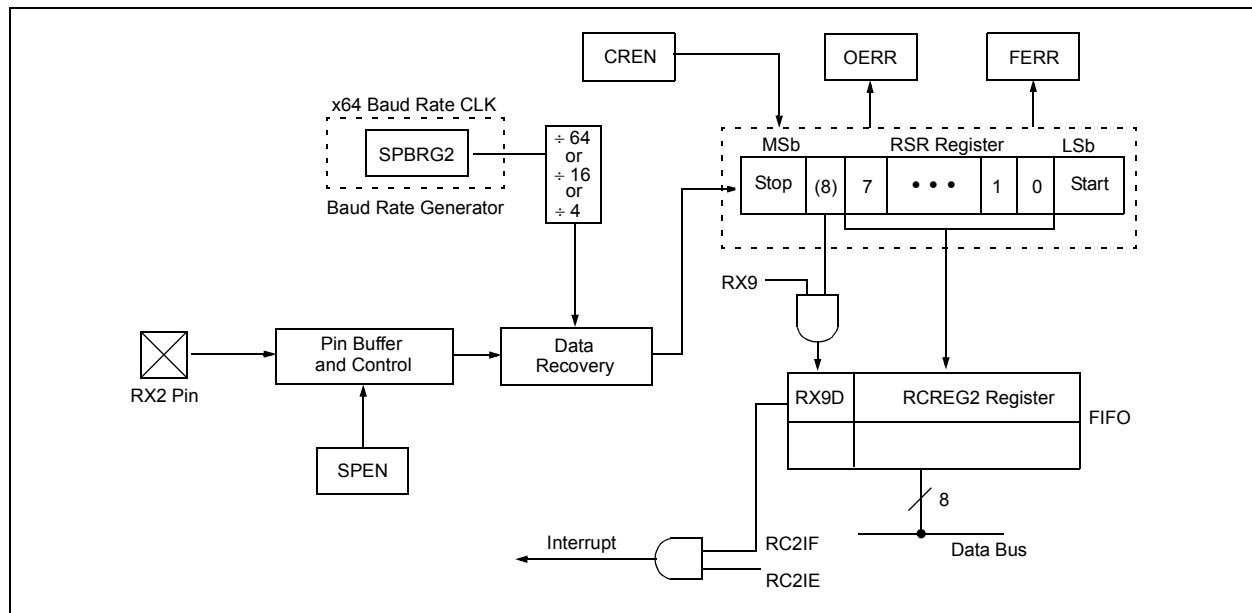
1. Initialize the SPBRG2 register for the appropriate baud rate. Set or clear the BRGH bit, as required, to achieve the desired baud rate.
2. Enable the asynchronous serial port by clearing bit, SYNC, and setting bit, SPEN.
3. If interrupts are desired, set enable bit, RC2IE.
4. If 9-bit reception is desired, set bit, RX9.
5. Enable the reception by setting bit, CREN.
6. Flag bit, RC2IF, will be set when reception is complete and an interrupt will be generated if enable bit, RC2IE, was set.
7. Read the RCSTA2 register to get the 9th bit (if enabled) and determine if any error occurred during reception.
8. Read the 8-bit received data by reading the RCREG2 register.
9. If any error occurred, clear the error by clearing enable bit, CREN.
10. If using interrupts, ensure that the GIE and PEIE bits in the INTCON register (INTCON<7:6>) are set.

## 20.3.3 SETTING UP 9-BIT MODE WITH ADDRESS DETECT

This mode would typically be used in RS-485 systems. To set up an Asynchronous Reception with Address Detect Enable:

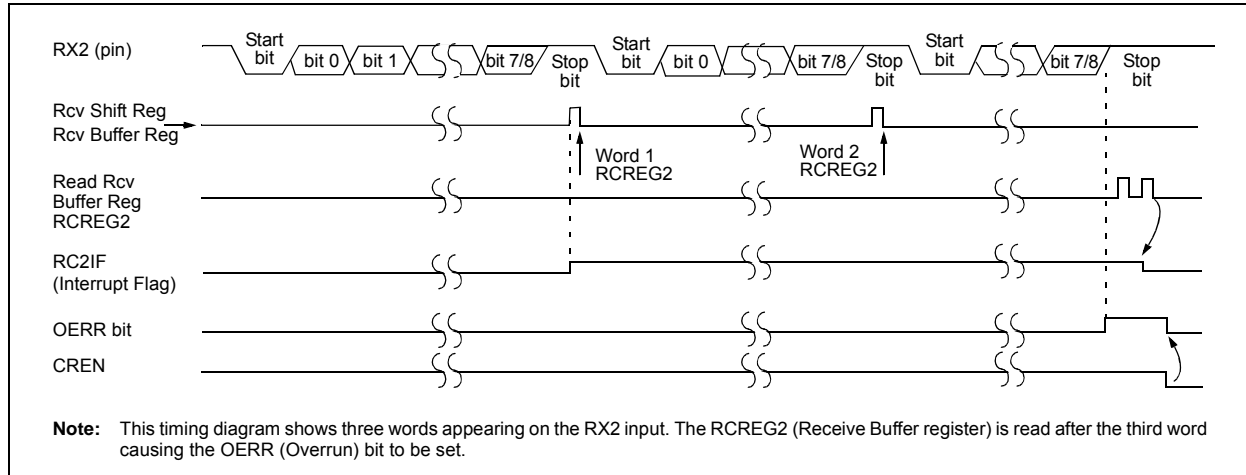
1. Initialize the SPBRG2 register for the appropriate baud rate. Set or clear the BRGH and BRG16 bits, as required, to achieve the desired baud rate.
2. Enable the asynchronous serial port by clearing the SYNC bit and setting the SPEN bit.
3. If interrupts are required, set the RCEN bit and select the desired priority level with the RC2IP bit.
4. Set the RX9 bit to enable 9-bit reception.
5. Set the ADDEN bit to enable address detect.
6. Enable reception by setting the CREN bit.
7. The RC2IF bit will be set when reception is complete. The interrupt will be Acknowledged if the RC2IE and GIE bits are set.
8. Read the RCSTA2 register to determine if any error occurred during reception, as well as read bit 9 of data (if applicable).
9. Read RCREG2 to determine if the device is being addressed.
10. If any error occurred, clear the CREN bit.
11. If the device has been addressed, clear the ADDEN bit to allow all received data into the receive buffer and interrupt the CPU.

**FIGURE 20-4: AUSART RECEIVE BLOCK DIAGRAM**



# PIC18F87J72

**FIGURE 20-5: ASYNCHRONOUS RECEPTION**



**TABLE 20-5: REGISTERS ASSOCIATED WITH ASYNCHRONOUS RECEPTION**

Name	Bit 7	Bit 6	Bit 5	Bit 4	Bit 3	Bit 2	Bit 1	Bit 0	Reset Values on Page
INTCON	GIE/GIE H	PEIE/GIE L	TMR0IE	INT0IE	RBIE	TMR0IF	INT0IF	RBIF	45
PIR3	—	LCDIF	RC2IF	TX2IF	CTMUIF	CCP2IF	CCP1IF	RTCCIF	48
PIE3	—	LCDIE	RC2IE	TX2IE	CTMUIE	CCP2IE	CCP1IE	RTCCIE	48
IPR3	—	LCDIP	RC2IP	TX2IP	CTMUIP	CCP2IP	CCP1IP	RTCCIP	48
RCSTA2	SPEN	RX9	SREN	CREN	ADDEN	FERR	OERR	RX9D	50
RCREG2	AUSART Receive Register								50
TXSTA2	CSRC	TX9	TXEN	SYNC	—	BRGH	TRMT	TX9D	50
SPBRG2	AUSART Baud Rate Generator Register								50

Legend: — = unimplemented locations read as '0'. Shaded cells are not used for asynchronous reception.

## 20.4 AUSART Synchronous Master Mode

The Synchronous Master mode is entered by setting the CSRC bit (TXSTA2<7>). In this mode, the data is transmitted in a half-duplex manner (i.e., transmission and reception do not occur at the same time). When transmitting data, the reception is inhibited and vice versa. Synchronous mode is entered by setting bit, SYNC (TXSTA2<4>). In addition, enable bit, SPEN (RCSTA2<7>), is set in order to configure the TX2 and RX2 pins to CK2 (clock) and DT2 (data) lines, respectively.

The Master mode indicates that the processor transmits the master clock on the CK2 line.

### 20.4.1 AUSART SYNCHRONOUS MASTER TRANSMISSION

The AUSART transmitter block diagram is shown in Figure 20-1. The heart of the transmitter is the Transmit (Serial) Shift register (TSR). The Shift register obtains its data from the Read/Write Transmit Buffer register: TXREG2. The TXREG2 register is loaded with data in software. The TSR register is not loaded until the last bit has been transmitted from the previous load. As soon as the last bit is transmitted, the TSR is loaded with new data from the TXREG2 (if available).

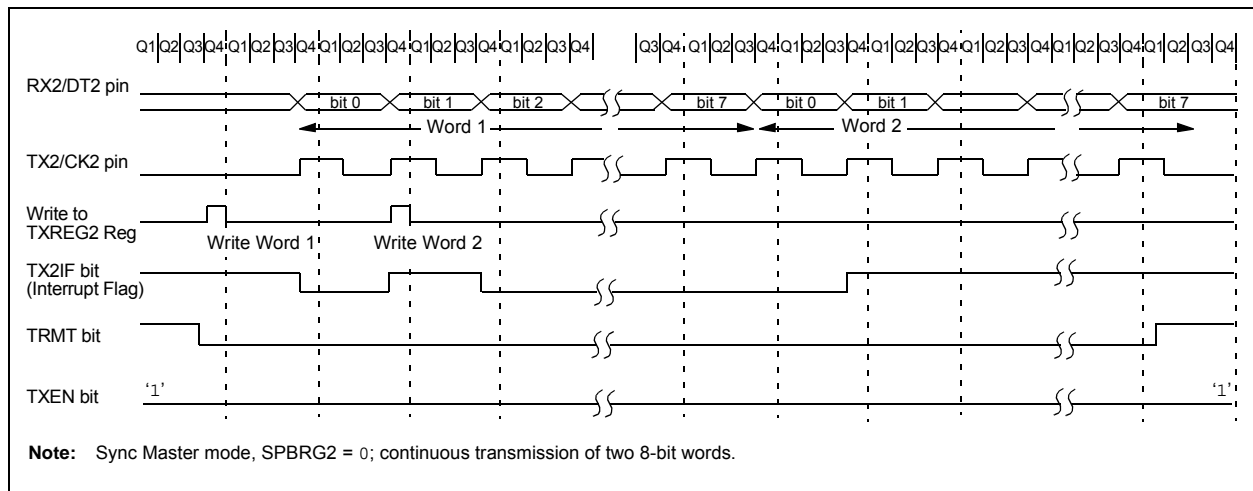
Once the TXREG2 register transfers the data to the TSR register (occurs in one T<sub>CYCLE</sub>), the TXREG2 is empty and the TX2IF flag bit (PIR3<4>) is set. The interrupt can be enabled or disabled by setting or clearing the interrupt enable bit, TX2IE (PIE3<4>). TX2IF is set regardless of the state of enable bit, TX2IE; it cannot be cleared in software. It will reset only when new data is loaded into the TXREG2 register.

While flag bit, TX2IF, indicates the status of the TXREG2 register, another bit, TRMT (TXSTA2<1>), shows the status of the TSR register. TRMT is a read-only bit which is set when the TSR is empty. No interrupt logic is tied to this bit so the user has to poll this bit in order to determine if the TSR register is empty. The TSR is not mapped in data memory so it is not available to the user.

To set up a Synchronous Master Transmission:

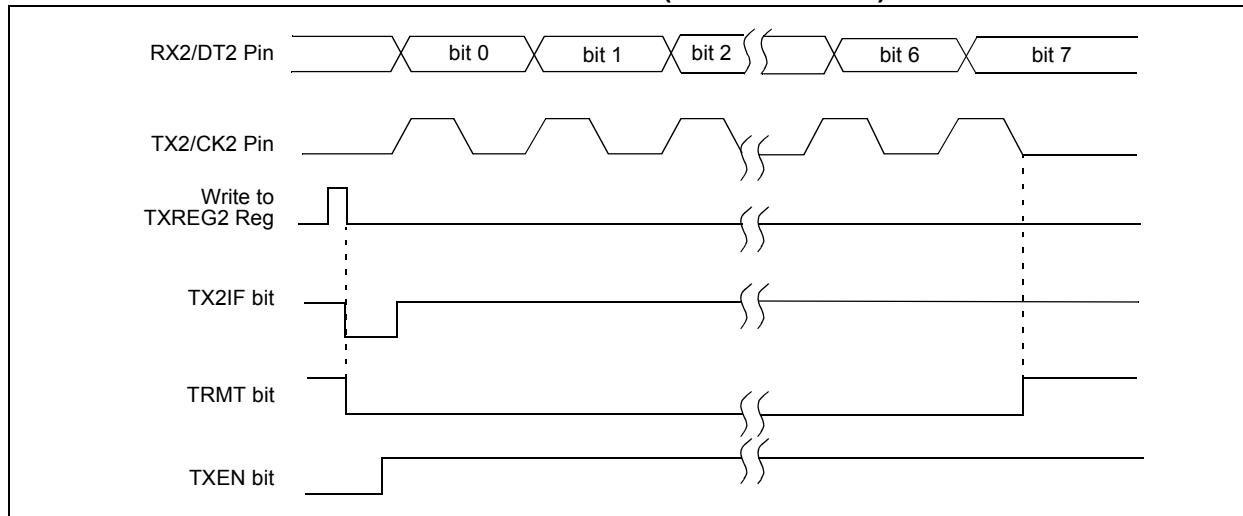
1. Initialize the SPBRG2 register for the appropriate baud rate.
2. Enable the synchronous master serial port by setting bits, SYNC, SPEN and CSRC.
3. If interrupts are desired, set enable bit, TX2IE.
4. If 9-bit transmission is desired, set bit, TX9.
5. Enable the transmission by setting bit, TXEN.
6. If 9-bit transmission is selected, the ninth bit should be loaded in bit, TX9D.
7. Start transmission by loading data to the TXREG2 register.
8. If using interrupts, ensure that the GIE and PEIE bits in the INTCON register (INTCON<7:6>) are set.

**FIGURE 20-6: SYNCHRONOUS TRANSMISSION**



# PIC18F87J72

**FIGURE 20-7: SYNCHRONOUS TRANSMISSION (THROUGH TXEN)**



**TABLE 20-6: REGISTERS ASSOCIATED WITH SYNCHRONOUS MASTER TRANSMISSION**

Name	Bit 7	Bit 6	Bit 5	Bit 4	Bit 3	Bit 2	Bit 1	Bit 0	Reset Values on Page
INTCON	GIE/GIEH	PEIE/GIEL	TMR0IE	INT0IE	RBIE	TMR0IF	INT0IF	RBIF	45
PIR3	—	LCDIF	RC2IF	TX2IF	CTMUIF	CCP2IF	CCP1IF	RTCCIF	48
PIE3	—	LCDIE	RC2IE	TX2IE	CTMUIE	CCP2IE	CCP1IE	RTCCIE	48
IPR3	—	LCDIP	RC2IP	TX2IP	CTMUIP	CCP2IP	CCP1IP	RTCCIP	48
RCSTA2	SPEN	RX9	SREN	CREN	ADDEN	FERR	OERR	RX9D	50
TXREG2	AUSART Transmit Register								50
TXSTA2	CSRC	TX9	TXEN	SYNC	—	BRGH	TRMT	TX9D	50
SPBRG2	AUSART Baud Rate Generator Register								50
LATG	U2OD	U1OD	—	LATG4	LATG3	LATG2	LATG1	LATG0	48

Legend: — = unimplemented, read as '0'. Shaded cells are not used for synchronous master transmission.

## 20.4.2 AUSART SYNCHRONOUS MASTER RECEPTION

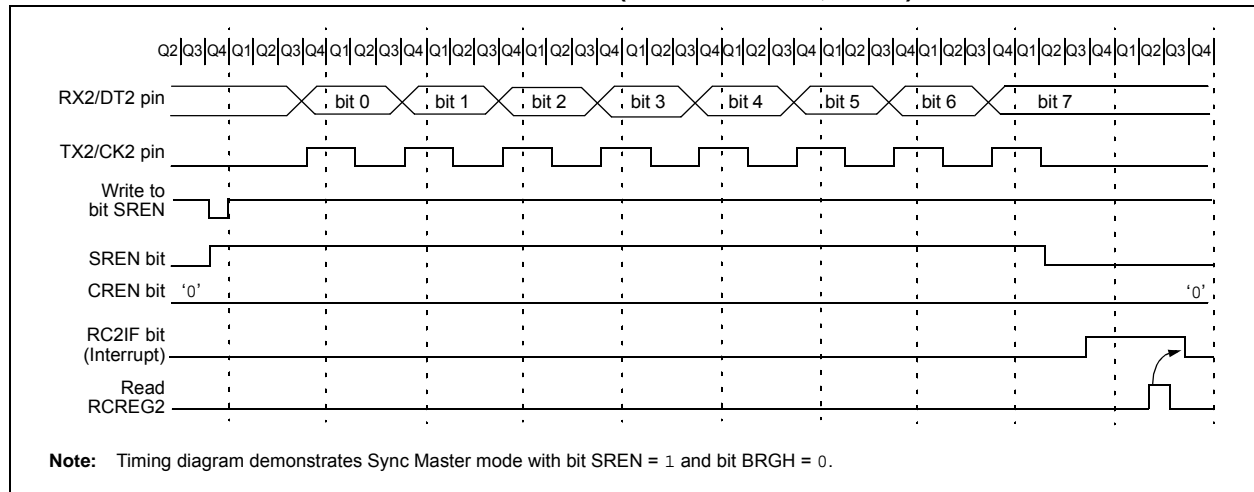
Once Synchronous mode is selected, reception is enabled by setting either the Single Receive Enable bit, SREN (RCSTA2<5>), or the Continuous Receive Enable bit, CREN (RCSTA2<4>). Data is sampled on the RX2 pin on the falling edge of the clock.

If enable bit, SREN, is set, only a single word is received. If enable bit, CREN, is set, the reception is continuous until CREN is cleared. If both bits are set, then CREN takes precedence.

To set up a Synchronous Master Reception:

1. Initialize the SPBRG2 register for the appropriate baud rate.
2. Enable the synchronous master serial port by setting bits, SYNC, SPEN and CSRC.
3. Ensure bits, CREN and SREN, are clear.
4. If interrupts are desired, set enable bit, RC2IE.
5. If 9-bit reception is desired, set bit, RX9.
6. If a single reception is required, set bit, SREN. For continuous reception, set bit, CREN.
7. Interrupt flag bit, RC2IF, will be set when reception is complete and an interrupt will be generated if the enable bit, RC2IE, was set.
8. Read the RCSTA2 register to get the 9th bit (if enabled) and determine if any error occurred during reception.
9. Read the 8-bit received data by reading the RCREG2 register.
10. If any error occurred, clear the error by clearing bit, CREN.
11. If using interrupts, ensure that the GIE and PEIE bits in the INTCON register (INTCON<7:6>) are set.

**FIGURE 20-8: SYNCHRONOUS RECEPTION (MASTER MODE, SREN)**



**TABLE 20-7: REGISTERS ASSOCIATED WITH SYNCHRONOUS MASTER RECEPTION**

Name	Bit 7	Bit 6	Bit 5	Bit 4	Bit 3	Bit 2	Bit 1	Bit 0	Reset Values on Page
INTCON	GIE/GIEH	PEIE/GIEL	TMR0IE	INT0IE	RBIE	TMR0IF	INT0IF	RBIF	45
PIR3	—	LCDIF	RC2IF	TX2IF	CTMUIF	CCP2IF	CCP1IF	RTCCIF	48
PIE3	—	LCDIE	RC2IE	TX2IE	CTMUIE	CCP2IE	CCP1IE	RTCCIE	48
IPR3	—	LCDIP	RC2IP	TX2IP	CTMUIP	CCP2IP	CCP1IP	RTCCIP	48
RCSTA2	SPEN	RX9	SREN	CREN	ADDEN	FERR	OERR	RX9D	50
RCREG2	AUSART Receive Register								50
TXSTA2	CSRC	TX9	TXEN	SYNC	—	BRGH	TRMT	TX9D	50
SPBRG2	AUSART Baud Rate Generator Register								50

Legend: — = unimplemented, read as '0'. Shaded cells are not used for synchronous master reception.

# PIC18F87J72

## 20.5 AUSART Synchronous Slave Mode

Synchronous Slave mode is entered by clearing bit, CSRC (TXSTA2<7>). This mode differs from the Synchronous Master mode in that the shift clock is supplied externally at the CK2 pin (instead of being supplied internally in Master mode). This allows the device to transfer or receive data while in any low-power mode.

### 20.5.1 AUSART SYNCHRONOUS SLAVE TRANSMIT

The operation of the Synchronous Master and Slave modes are identical except in the case of the Sleep mode.

If two words are written to the TXREG2 and then the SLEEP instruction is executed, the following will occur:

- a) The first word will immediately transfer to the TSR register and transmit.
- b) The second word will remain in the TXREG2 register.
- c) Flag bit, TX2IF, will not be set.
- d) When the first word has been shifted out of TSR, the TXREG2 register will transfer the second word to the TSR and flag bit, TX2IF, will now be set.
- e) If enable bit, TX2IE, is set, the interrupt will wake the chip from Sleep. If the global interrupt is enabled, the program will branch to the interrupt vector.

To set up a Synchronous Slave Transmission:

1. Enable the synchronous slave serial port by setting bits, SYNC and SPEN, and clearing bit, CSRC.
2. Clear bits, CREN and SREN.
3. If interrupts are desired, set enable bit, TX2IE.
4. If 9-bit transmission is desired, set bit, TX9.
5. Enable the transmission by setting enable bit, TXEN.
6. If 9-bit transmission is selected, the ninth bit should be loaded in bit, TX9D.
7. Start transmission by loading data to the TXREG2 register.
8. If using interrupts, ensure that the GIE and PEIE bits in the INTCON register (INTCON<7:6>) are set.

**TABLE 20-8: REGISTERS ASSOCIATED WITH SYNCHRONOUS SLAVE TRANSMISSION**

Name	Bit 7	Bit 6	Bit 5	Bit 4	Bit 3	Bit 2	Bit 1	Bit 0	Reset Values on Page
INTCON	GIE/GIEH	PEIE/GIEL	TMR0IE	INT0IE	RBIE	TMR0IF	INT0IF	RBIF	45
PIR3	—	LCDIF	RC2IF	TX2IF	CTMUIF	CCP2IF	CCP1IF	RTCCIF	48
PIE3	—	LCDIE	RC2IE	TX2IE	CTMUIE	CCP2IE	CCP1IE	RTCCIE	48
IPR3	—	LCDIP	RC2IP	TX2IP	CTMUIP	CCP2IP	CCP1IP	RTCCIP	48
RCSTA2	SPEN	RX9	SREN	CREN	ADDEN	FERR	OERR	RX9D	50
TXREG2	AUSART Transmit Register								50
TXSTA2	CSRC	TX9	TXEN	SYNC	—	BRGH	TRMT	TX9D	50
SPBRG2	AUSART Baud Rate Generator Register								50
LATG	U2OD	U1OD	—	LATG4	LATG3	LATG2	LATG1	LATG0	48

Legend: — = unimplemented, read as '0'. Shaded cells are not used for synchronous slave transmission.



## 20.5.2 AUSART SYNCHRONOUS SLAVE RECEPTION

The operation of the Synchronous Master and Slave modes is identical except in the case of Sleep or any Idle mode, and bit SREN, which is a “don’t care” in Slave mode.

If receive is enabled by setting the CREN bit prior to entering Sleep, or any Idle mode, then a word may be received while in this low-power mode. Once the word is received, the RSR register will transfer the data to the RCREG2 register; if the RC2IE enable bit is set, the interrupt generated will wake the chip from low-power mode. If the global interrupt is enabled, the program will branch to the interrupt vector.

To set up a Synchronous Slave Reception:

1. Enable the synchronous master serial port by setting bits, SYNC and SPEN, and clearing bit, CSRC.
2. If interrupts are desired, set enable bit, RC2IE.
3. If 9-bit reception is desired, set bit, RX9.
4. To enable reception, set enable bit, CREN.
5. Flag bit, RC2IF, will be set when reception is complete. An interrupt will be generated if enable bit, RC2IE, was set.
6. Read the RCSTA2 register to get the 9th bit (if enabled) and determine if any error occurred during reception.
7. Read the 8-bit received data by reading the RCREG2 register.
8. If any error occurred, clear the error by clearing bit, CREN.
9. If using interrupts, ensure that the GIE and PEIE bits in the INTCON register (INTCON<7:6>) are set.

**TABLE 20-9: REGISTERS ASSOCIATED WITH SYNCHRONOUS SLAVE RECEPTION**

Name	Bit 7	Bit 6	Bit 5	Bit 4	Bit 3	Bit 2	Bit 1	Bit 0	Reset Values on Page
INTCON	GIE/GIE H	PEIE/GIE L	TMR0IE	INT0IE	RBIE	TMR0IF	INT0IF	RBIF	45
PIR3	—	LCDIF	RC2IF	TX2IF	CTMUIF	CCP2IF	CCP1IF	RTCCIF	48
PIE3	—	LCDIE	RC2IE	TX2IE	CTMUIE	CCP2IE	CCP1IE	RTCCIE	48
IPR3	—	LCDIP	RC2IP	TX2IP	CTMUIP	CCP2IP	CCP1IP	RTCCIP	48
RCSTA2	SPEN	RX9	SREN	CREN	ADDEN	FERR	OERR	RX9D	50
RCREG2	AUSART Receive Register								50
TXSTA2	CSRC	TX9	TXEN	SYNC	—	BRGH	TRMT	TX9D	50
SPBRG2	AUSART Baud Rate Generator Register								50

Legend: — = unimplemented, read as '0'. Shaded cells are not used for synchronous slave reception.

# PIC18F87J72

## 21.0 12-BIT ANALOG-TO-DIGITAL CONVERTER (A/D) MODULE

The Analog-to-Digital (A/D) Converter module has 12 inputs for all PIC18F87J72 family devices. This module allows conversion of an analog input signal to a corresponding 12-bit digital number.

The module has these registers:

- A/D Result High Register (ADRESH)
- A/D Result Low Register (ADRESL)
- A/D Control Register 0 (ADCON0)
- A/D Control Register 1 (ADCON1)
- A/D Control Register 2 (ADCON2)

The ADCON0 register, shown in [Register 21-1](#), controls the operation of the A/D module. The ADCON1 register, shown in [Register 21-2](#), configures the functions of the port pins. The ADCON2 register, shown in [Register 21-3](#), configures the A/D clock source, programmed acquisition time and justification.

### REGISTER 21-1: ADCON0: A/D CONTROL REGISTER 0

R/W-0	U-0	R/W-0	R/W-0	R/W-0	R/W-0	R/W-0	R/W-0
ADCAL	—	CHS3	CHS2	CHS1	CHS0	GO/DONE	ADON
bit 7							bit 0

#### Legend:

R = Readable bit

W = Writable bit

U = Unimplemented bit, read as '0'

-n = Value at POR

'1' = Bit is set

'0' = Bit is cleared

x = Bit is unknown

- bit 7      **ADCAL:** A/D Calibration bit  
1 = Calibration is performed on the next A/D conversion  
0 = Normal A/D Converter operation (no calibration is performed)
- bit 6      **Unimplemented:** Read as '0'
- bit 5-2    **CHS<3:0>:** Analog Channel Select bits  
0000 = Channel 00 (AN0)  
0001 = Channel 01 (AN1)  
0010 = Channel 02 (AN2)  
0011 = Channel 03 (AN3)  
0100 = Channel 04 (AN4)  
0101 = Channel 05 (AN5)  
0110 = Channel 06 (AN6)  
0111 = Channel 07 (AN7)  
1000 = Channel 08 (AN8)  
1001 = Channel 09 (AN9)  
1010 = Channel 10 (AN10)  
1011 = Channel 11 (AN11)  
11xx = Unused
- bit 1      **GO/DONE:** A/D Conversion Status bit  
When ADON = 1:  
1 = A/D conversion is in progress  
0 = A/D is Idle
- bit 0      **ADON:** A/D On bit  
1 = A/D Converter module is enabled  
0 = A/D Converter module is disabled

## REGISTER 21-2: ADCON1: A/D CONTROL REGISTER 1

R/W-0	U-0	R/W-0	R/W-0	R/W-0	R/W-0	R/W-0	R/W-0
TRIGSEL	—	VCFG1	VCFG0	PCFG3	PCFG2	PCFG1	PCFG0
bit 7							bit 0

### Legend:

R = Readable bit                      W = Writable bit                      U = Unimplemented bit, read as '0'  
 -n = Value at POR                      '1' = Bit is set                      '0' = Bit is cleared                      x = Bit is unknown

- bit 7            **TRIGSEL:** Special Trigger Select bit  
 1 = Selects the special trigger from the CTMU  
 0 = Selects the special trigger from the CCP2
- bit 6            **Unimplemented:** Read as '0'
- bit 5            **VCFG1:** Voltage Reference Configuration bit (VREF- source)  
 1 = VREF- (AN2)  
 0 = AVSS
- bit 4            **VCFG0:** Voltage Reference Configuration bit (VREF+ source)  
 1 = VREF+ (AN3)  
 0 = AVDD
- bit 3-0        **PCFG<3:0>:** A/D Port Configuration Control bits:

PCFG<3:0>	AN11	AN10	AN9	AN8	AN7	AN6	AN5	AN4	AN3	AN2	AN1	AN0
0000	A	A	A	A	A	A	A	A	A	A	A	A
0001	A	A	A	A	A	A	A	A	A	A	A	A
0010	A	A	A	A	A	A	A	A	A	A	A	A
0011	A	A	A	A	A	A	A	A	A	A	A	A
0100	D	A	A	A	A	A	A	A	A	A	A	A
0101	D	D	A	A	A	A	A	A	A	A	A	A
0110	D	D	D	A	A	A	A	A	A	A	A	A
0111	D	D	D	D	A	A	A	A	A	A	A	A
1000	D	D	D	D	D	A	A	A	A	A	A	A
1001	D	D	D	D	D	D	A	A	A	A	A	A
1010	D	D	D	D	D	D	D	A	A	A	A	A
1011	D	D	D	D	D	D	D	D	A	A	A	A
1100	D	D	D	D	D	D	D	D	D	A	A	A
1101	D	D	D	D	D	D	D	D	D	D	A	A
1110	D	D	D	D	D	D	D	D	D	D	D	A
1111	D	D	D	D	D	D	D	D	D	D	D	D

A = Analog input

D = Digital I/O

# PIC18F87J72

## REGISTER 21-3: ADCON2: A/D CONTROL REGISTER 2

R/W-0	U-0	R/W-0	R/W-0	R/W-0	R/W-0	R/W-0	R/W-0
ADFM	—	ACQT2	ACQT1	ACQT0	ADCS2	ADCS1	ADCS0
bit 7							bit 0

### Legend:

R = Readable bit

W = Writable bit

U = Unimplemented bit, read as '0'

-n = Value at POR

'1' = Bit is set

'0' = Bit is cleared

x = Bit is unknown

- bit 7      **ADFM:** A/D Result Format Select bit  
          1 = Right justified  
          0 = Left justified
- bit 6      **Unimplemented:** Read as '0'
- bit 5-3    **ACQT<2:0>:** A/D Acquisition Time Select bits  
          111 = 20 TAD  
          110 = 16 TAD  
          101 = 12 TAD  
          100 = 8 TAD  
          011 = 6 TAD  
          010 = 4 TAD  
          001 = 2 TAD  
          000 = 0 TAD<sup>(1)</sup>
- bit 2-0    **ADCS<2:0>:** A/D Conversion Clock Select bits  
          111 = FRC (clock derived from A/D RC oscillator)<sup>(1)</sup>  
          110 = FOSC/64  
          101 = FOSC/16  
          100 = FOSC/4  
          011 = FRC (clock derived from A/D RC oscillator)<sup>(1)</sup>  
          010 = FOSC/32  
          001 = FOSC/8  
          000 = FOSC/2

**Note 1:** If the A/D FRC clock source is selected, a delay of one TCY (instruction cycle) is added before the A/D clock starts. This allows the *SLEEP* instruction to be executed before starting a conversion.

The analog reference voltage is software selectable to either the device's positive and negative supply voltage (AVDD and AVSS) or the voltage level on the RA3/AN3/VREF+ and RA2/AN2/VREF- pins.

The A/D Converter has a unique feature of being able to operate while the device is in Sleep mode. To operate in **Sleep**, the A/D conversion clock must be derived from the A/D's internal RC oscillator.

The output of the sample and hold is the input into the converter, which generates the result via successive approximation.

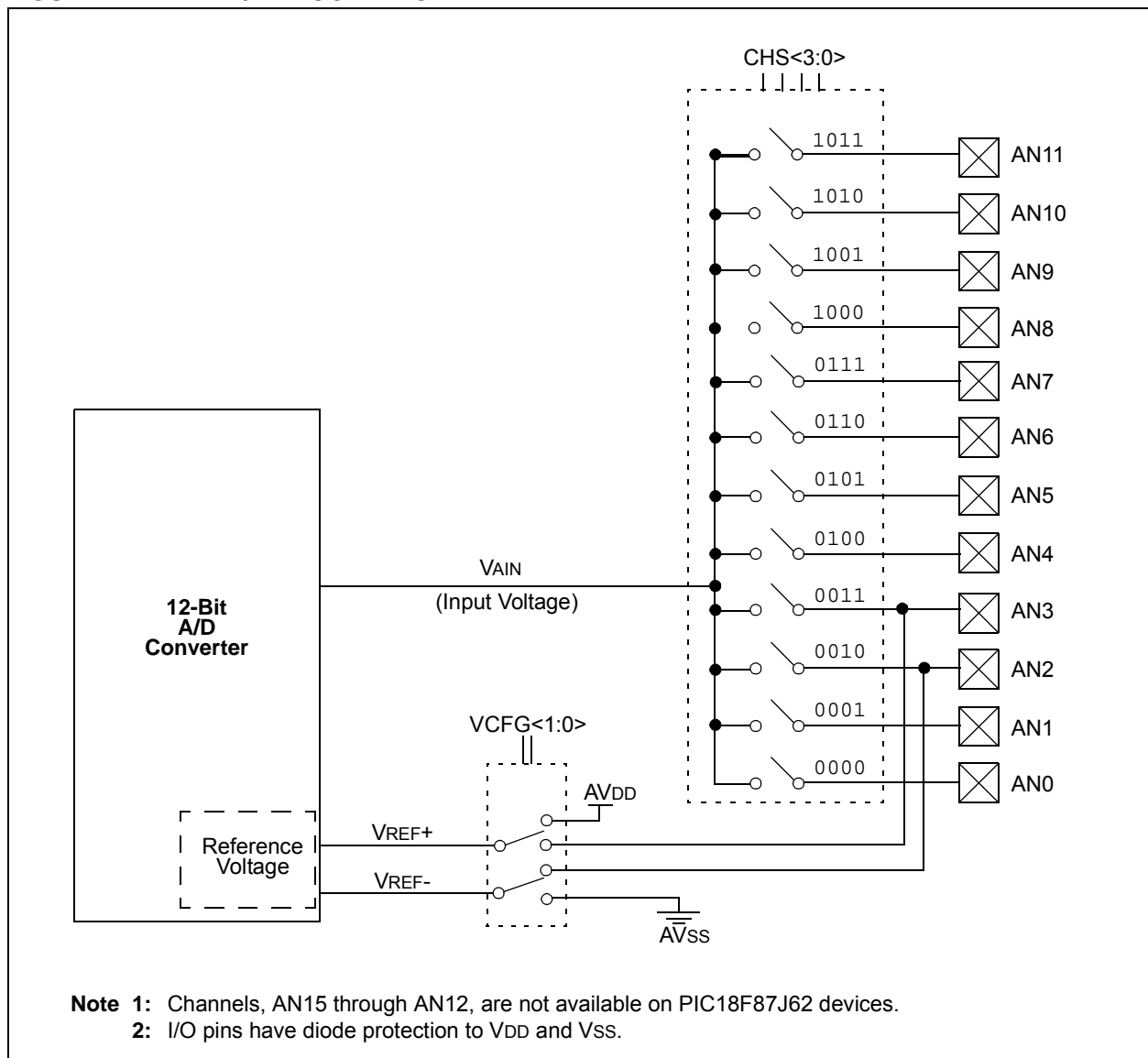
Each port pin associated with the A/D Converter can be configured as an analog input or as a digital I/O. The ADRESH and ADRESL registers contain the result of the

A/D conversion. When the A/D conversion is complete, the result is loaded into the ADRESH:ADRESL register pair, the GO/DONE bit (ADCON0<1>) is cleared and the A/D Interrupt Flag bit, ADIF, is set.

A device Reset forces all registers to their Reset state. This forces the A/D module to be turned off and any conversion in progress is aborted. The value in the ADRESH:ADRESL register pair is not modified for a Power-on Reset. These registers will contain unknown data after a Power-on Reset.

The block diagram of the A/D module is shown in [Figure 21-1](#).

**FIGURE 21-1: A/D BLOCK DIAGRAM<sup>(1,2)</sup>**



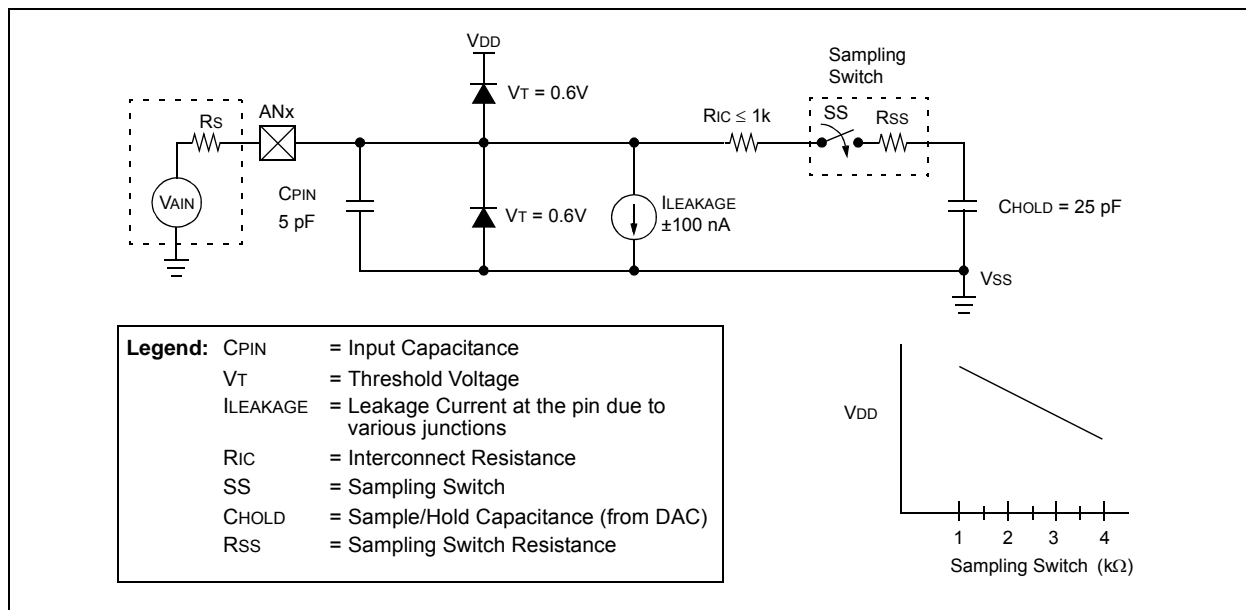
# PIC18F87J72

After the A/D module has been configured as desired, the selected channel must be acquired before the conversion is started. The analog input channels must have their corresponding TRIS bits selected as inputs. To determine acquisition time, see [Section 21.1 “A/D Acquisition Requirements”](#). After this acquisition time has elapsed, the A/D conversion can be started. An acquisition time can be programmed to occur between setting the GO/DONE bit and the actual start of the conversion.

The following steps should be followed to do an A/D conversion:

1. Configure the A/D module:
  - Configure analog pins, voltage reference and digital I/O (ADCON1)
  - Select A/D input channel (ADCON0)
  - Select A/D acquisition time (ADCON2)
  - Select A/D conversion clock (ADCON2)
  - Turn on A/D module (ADCON0)
2. Configure A/D interrupt (if desired):
  - Clear ADIF bit
  - Set ADIE bit
  - Set GIE bit
3. Wait the required acquisition time (if required).
4. Start conversion:
  - Set GO/DONE bit (ADCON0<1>)
5. Wait for A/D conversion to complete, by either:
  - Polling for the GO/DONE bit to be cleared
 OR
  - Waiting for the A/D interrupt
6. Read A/D Result registers (ADRESH:ADRESL); clear ADIF bit, if required.
7. For next conversion, go to step 1 or step 2, as required. The A/D conversion time per bit is defined as TAD. A minimum wait of 2 TAD is required before the next acquisition starts.

**FIGURE 21-2: ANALOG INPUT MODEL**



## 21.1 A/D Acquisition Requirements

For the A/D Converter to meet its specified accuracy, the Charge Holding Capacitor (CHOLD) must be allowed to fully charge to the input channel voltage level. The analog input model is shown in Figure 21-2. The source impedance (Rs) and the internal sampling switch (Rss) impedance directly affect the time required to charge the capacitor, CHOLD. The sampling switch (Rss) impedance varies over the device voltage (VDD). The source impedance affects the offset voltage at the analog input (due to pin leakage current). **The maximum recommended impedance for analog sources is 2.5 kΩ.** After the analog input channel is selected (changed), the channel must be sampled for at least the minimum acquisition time before starting a conversion.

**Note:** When the conversion is started, the holding capacitor is disconnected from the input pin.

To calculate the minimum acquisition time, Equation 21-1 may be used. This equation assumes that 1/2 LSB error is used (1,024 steps for the A/D). The 1/2 LSB error is the maximum error allowed for the A/D to meet its specified resolution.

Equation 21-3 shows the calculation of the minimum required acquisition time, TACQ. This calculation is based on the following application system assumptions:

CHOLD	=	25 pF
Rs	=	2.5 kΩ
Conversion Error	≤	1/2 LSB
VDD	=	3V → Rss = 2 kΩ
Temperature	=	85°C (system max.)

### EQUATION 21-1: ACQUISITION TIME

$$T_{ACQ} = \text{Amplifier Settling Time} + \text{Holding Capacitor Charging Time} + \text{Temperature Coefficient}$$

$$= T_{AMP} + T_C + T_{COFF}$$

### EQUATION 21-2: A/D MINIMUM CHARGING TIME

$$V_{HOLD} = (V_{REF} - (V_{REF}/2048)) \cdot (1 - e^{-(T_C/CHOLD)(R_{IC} + R_{SS} + R_S)})$$

or

$$T_C = -(CHOLD)(R_{IC} + R_{SS} + R_S) \ln(1/2048)$$

### EQUATION 21-3: CALCULATING THE MINIMUM REQUIRED ACQUISITION TIME

$$T_{ACQ} = T_{AMP} + T_C + T_{COFF}$$

$$T_{AMP} = 0.2 \mu s$$

$$T_{COFF} = (Temp - 25^\circ C)(0.02 \mu s/^\circ C)$$

$$(85^\circ C - 25^\circ C)(0.02 \mu s/^\circ C)$$

$$1.2 \mu s$$

Temperature coefficient is only required for temperatures > 25°C. Below 25°C, TCOFF = 0 ms.

$$T_C = -(CHOLD)(R_{IC} + R_{SS} + R_S) \ln(1/2048) \mu s$$

$$-(25 pF)(1 k\Omega + 2 k\Omega + 2.5 k\Omega) \ln(0.0004883) \mu s$$

$$1.05 \mu s$$

$$T_{ACQ} = 0.2 \mu s + 1 \mu s + 1.2 \mu s$$

$$2.4 \mu s$$

## 21.2 Selecting and Configuring Automatic Acquisition Time

The ADCON2 register allows the user to select an acquisition time that occurs each time the GO/DONE bit is set.

When the GO/DONE bit is set, sampling is stopped and a conversion begins. The user is responsible for ensuring the required acquisition time has passed between selecting the desired input channel and setting the GO/DONE bit. This occurs when the ACQT<2:0> bits (ADCON2<5:3>) remain in their Reset state ('000') and is compatible with devices that do not offer programmable acquisition times.

If desired, the ACQT bits can be set to select a programmable acquisition time for the A/D module. When the GO/DONE bit is set, the A/D module continues to sample the input for the selected acquisition time, then automatically begins a conversion. Since the acquisition time is programmed, there may be no need to wait for an acquisition time between selecting a channel and setting the GO/DONE bit.

In either case, when the conversion is completed, the GO/DONE bit is cleared, the ADIF flag is set and the A/D begins sampling the currently selected channel again. If an acquisition time is programmed, there is nothing to indicate if the acquisition time has ended or if the conversion has begun.

## 21.3 Selecting the A/D Conversion Clock

The A/D conversion time per bit is defined as TAD. The A/D conversion requires 11 TAD per 12-bit conversion. The source of the A/D conversion clock is software selectable.

There are seven possible options for TAD:

- 2 TOSC
- 4 TOSC
- 8 TOSC
- 16 TOSC
- 32 TOSC
- 64 TOSC
- Internal RC Oscillator

For correct A/D conversions, the A/D conversion clock (TAD) must be as short as possible but greater than the minimum TAD.

Table 21-1 shows the resultant TAD times derived from the device operating frequencies and the A/D clock source selected.

**TABLE 21-1: TAD vs. DEVICE OPERATING FREQUENCIES**

AD Clock Source (TAD)		Maximum Device Frequency
Operation	ADCS<2:0>	
2 TOSC	000	2.86 MHz
4 TOSC	100	5.71 MHz
8 TOSC	001	11.43 MHz
16 TOSC	101	22.86 MHz
32 TOSC	010	40.0 MHz
64 TOSC	110	40.0 MHz
RC <sup>(2)</sup>	x11	1.00 MHz <sup>(1)</sup>

- Note 1:** The RC source has a typical TAD time of 4  $\mu$ s.
- 2:** For device frequencies above 1 MHz, the device must be in Sleep mode for the entire conversion or the A/D accuracy may be out of specification.

## 21.4 Configuring Analog Port Pins

The ADCON1, TRISA, TRISF and TRISH registers control the operation of the A/D port pins. The port pins needed as analog inputs must have their corresponding TRIS bits set (input). If the TRIS bit is cleared (output), the digital output level (VOH or VOL) will be converted.

The A/D operation is independent of the state of the CHS<3:0> bits and the TRIS bits.

- Note 1:** When reading the PORT register, all pins configured as analog input channels will read as cleared (a low level). Pins configured as digital inputs will convert an analog input. Analog levels on a digitally configured input will be accurately converted.
- 2:** Analog levels on any pin defined as a digital input may cause the digital input buffer to consume current out of the device's specification limits.



## 21.5 A/D Conversions

Figure 21-1 shows the operation of the A/D Converter after the  $\overline{\text{GO/DONE}}$  bit has been set and the  $\text{ACQT}<2:0>$  bits are cleared. A conversion is started after the following instruction to allow entry into Sleep mode before the conversion begins.

Figure 21-2 shows the operation of the A/D Converter after the  $\overline{\text{GO/DONE}}$  bit has been set. The  $\text{ACQT}<2:0>$  bits are set to '010' and a 4 TAD acquisition time is selected before the conversion starts.

Clearing the  $\overline{\text{GO/DONE}}$  bit during a conversion will abort the current conversion. The A/D Result register pair will NOT be updated with the partially completed A/D conversion sample. This means the ADRESH:ADRESL registers will continue to contain the value of the last completed conversion (or the last value written to the ADRESH:ADRESL registers).

After the A/D conversion is completed or aborted, a 2 TAD wait is required before the next acquisition can be started. After this wait, acquisition on the selected channel is automatically started.

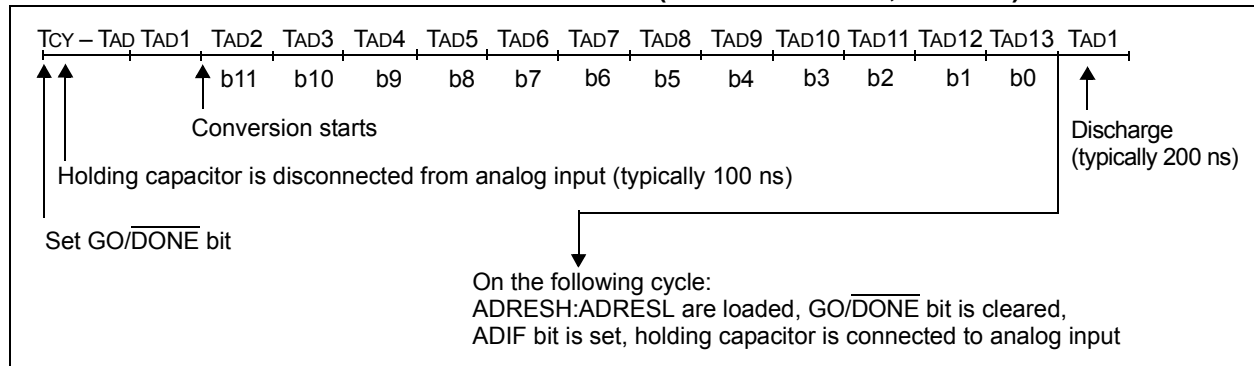
**Note:** The  $\overline{\text{GO/DONE}}$  bit should **NOT** be set in the same instruction that turns on the A/D.

## 21.6 Use of the CCP2 Trigger

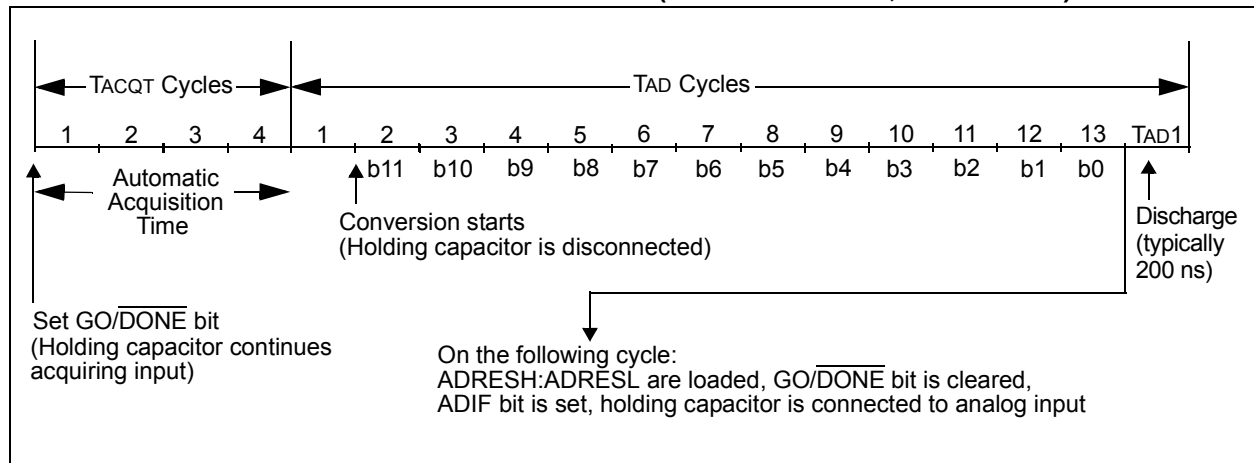
An A/D conversion can be started by the "Special Event Trigger" of the CCP2 module. This requires that the  $\text{CCP2M}<3:0>$  bits ( $\text{CCP2CON}<3:0>$ ) be programmed as '1011' and that the A/D module is enabled (ADON bit is set). When the trigger occurs, the  $\overline{\text{GO/DONE}}$  bit will be set, starting the A/D acquisition and conversion, and the Timer1 (or Timer3) counter will be reset to zero. Timer1 (or Timer3) is reset to automatically repeat the A/D acquisition period with minimal software overhead (moving ADRESH:ADRESL to the desired location). The appropriate analog input channel must be selected and the minimum acquisition period is either timed by the user or an appropriate TACQ time is selected before the Special Event Trigger sets the  $\overline{\text{GO/DONE}}$  bit (starts a conversion).

If the A/D module is not enabled (ADON is cleared), the Special Event Trigger will be ignored by the A/D module, but will still reset the Timer1 (or Timer3) counter.

**FIGURE 21-1: A/D CONVERSION TAD CYCLES ( $\text{ACQT}<2:0> = 000, \text{TACQ} = 0$ )**



**FIGURE 21-2: A/D CONVERSION TAD CYCLES ( $\text{ACQT}<2:0> = 010, \text{TACQ} = 4 \text{TAD}$ )**



# PIC18F87J72

## 21.7 A/D Converter Calibration

The A/D Converter in the PIC18F87J72 family of devices includes a self-calibration feature which compensates for any offset generated within the module. The calibration process is automated and is initiated by setting the ADCAL bit (ADCON0<7>). The next time the GO/DONE bit is set, the module will perform a “dummy” conversion (which means it is reading none of the input channels) and store the resulting value internally to compensate for the offset. Thus, subsequent offsets will be compensated.

The calibration process assumes that the device is in a relatively steady-state operating condition. If A/D calibration is used, it should be performed after each device Reset or if there are other major changes in operating conditions.

## 21.8 Operation in Power-Managed Modes

The selection of the automatic acquisition time and A/D conversion clock is determined in part by the clock source and frequency while in a power-managed mode.

If the A/D is expected to operate while the device is in a power-managed mode, the ACQT<2:0> and ADCS<2:0> bits in ADCON2 should be updated in accordance with the power-managed mode clock that will be used. After the power-managed mode is entered (either of the power-managed Run modes), an A/D acquisition or conversion may be started. Once an acquisition or conversion is started, the device should continue to be clocked by the same power-managed mode clock source until the conversion has been completed. If desired, the device may be placed into the corresponding power-managed Idle mode during the conversion.

If the power-managed mode clock frequency is less than 1 MHz, the A/D RC clock source should be selected.

Operation in Sleep mode requires the A/D RC clock to be selected. If bits, ACQT<2:0>, are set to ‘000’ and a conversion is started, the conversion will be delayed one instruction cycle to allow execution of the SLEEP instruction and entry to Sleep mode. The IDLEN and SCSx bits in the OSCCON register must have already been cleared prior to starting the conversion.

TABLE 21-2: SUMMARY OF A/D REGISTERS

Name	Bit 7	Bit 6	Bit 5	Bit 4	Bit 3	Bit 2	Bit 1	Bit 0	Reset Values on Page
INTCON	GIE/GIEH	PEIE/GIEL	TMR0IE	INT0IE	RBIE	TMR0IF	INT0IF	RBIF	45
PIR1	—	ADIF	RC1IF	TX1IF	SSPIF	—	TMR2IF	TMR1IF	48
PIE1	—	ADIE	RC1IE	TX1IE	SSPIE	—	TMR2IE	TMR1IE	48
IPR1	—	ADIP	RC1IP	TX1IP	SSPIP	—	TMR2IP	TMR1IP	48
PIR3	—	LCDIF	RC2IF	TX2IF	CTMUIF	CCP2IF	CCP1IF	RTCCIF	48
PIE3	—	LCDIE	RC2IE	TX2IE	CTMUIE	CCP2IE	CCP1IE	RTCCIE	48
IPR3	—	LCDIP	RC2IP	TX2IP	CTMUIP	CCP2IP	CCP1IP	RTCCIP	48
ADRESH	A/D Result Register High Byte								47
ADRESL	A/D Result Register Low Byte								47
ADCON0	ADCAL	—	CHS3	CHS2	CHS1	CHS0	GO/DONE	ADON	47
ADCON1	TRIGSEL	—	VCFG1	VCFG0	PCFG3	PCFG2	PCFG1	PCFG0	47
ADCON2	ADFM	—	ACQT2	ACQT1	ACQT0	ADCS2	ADCS1	ADCS0	47
CCP2CON	—	—	DC2B1	DC2B0	CCP2M3	CCP2M2	CCP2M1	CCP2M0	49
PORTA	RA7 <sup>(1)</sup>	RA6 <sup>(1)</sup>	RA5	RA4	RA3	RA2	RA1	RA0	48
TRISA	TRISA7 <sup>(1)</sup>	TRISA6 <sup>(1)</sup>	TRISA5	TRISA4	TRISA3	TRISA2	TRISA1	TRISA0	48
PORTF	RF7	RF6	RF5	RF4	RF3	RF2	RF1	—	48
TRISF	TRISF5	TRISF4	TRISF5	TRISF4	TRISF3	TRISF2	TRISF1	—	48

**Legend:** — = unimplemented, read as ‘0’. Shaded cells are not used for A/D conversion.

**Note 1:** RA<7:6> and their associated latch and direction bits are configured as port pins only when the internal oscillator is selected as the default clock source (FOSC2 Configuration bit = 0); otherwise, they are disabled and these bits read as ‘0’.

## 22.0 DUAL-CHANNEL, 24-BIT ANALOG FRONT END (AFE)

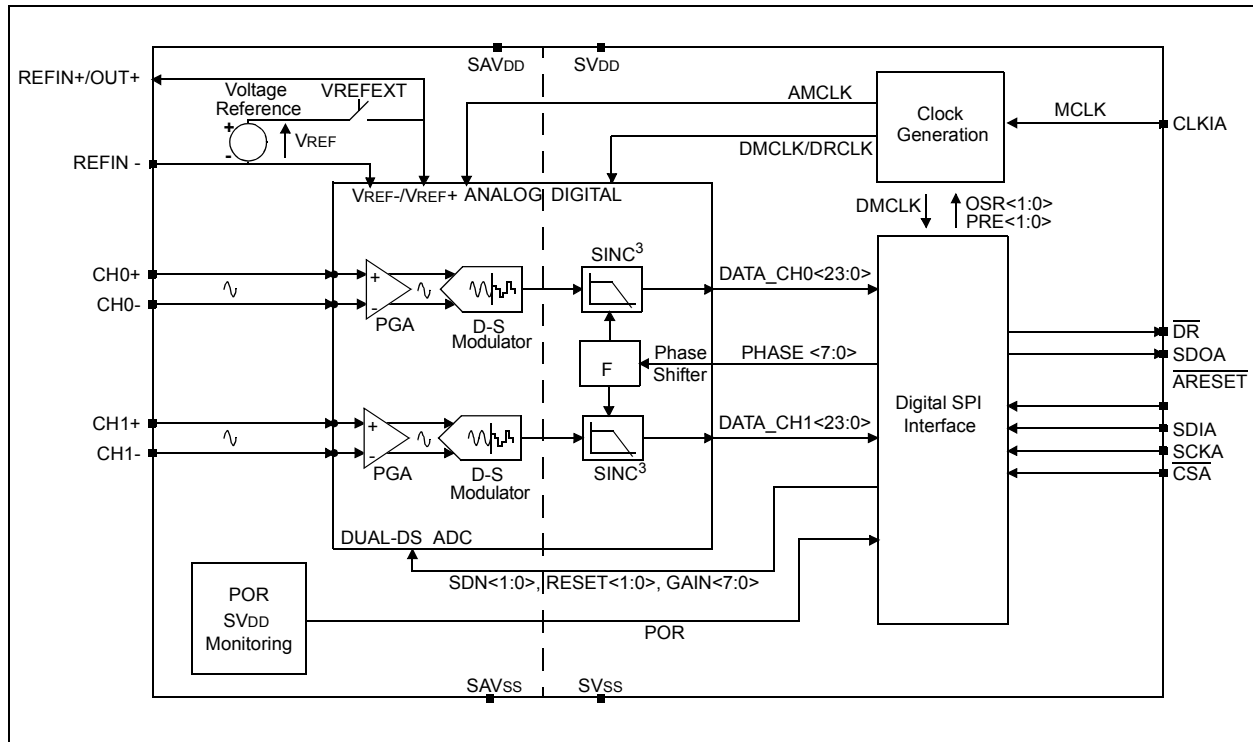
The dual-channel, 24-bit Analog Front End (AFE) is an integrated, high-performance analog subsystem that has been tailored for energy metering and power measurement applications. The AFE contains two synchronous sampling Delta-Sigma Analog-to-Digital Converters ( $\Delta-\Sigma$  ADC), two PGAs, a phase delay compensation block, an internal voltage reference and a dedicated, high-speed 20 MHz SPI compatible serial interface. A functional block diagram of the AFE is shown in Figure 22-1.

The A/D Converters contain a proprietary dithering algorithm for reduced Idle tones and improved THD. Each converter is preceded by a PGA, allowing for weak signal amplification and true differential voltage inputs to the converters. This allows the AFE to interface with a large variety of voltage and current sensors including shunts, current transformers, Rogowski coils and Hall effect sensors.

AFE data and control functions are accessed through a dedicated register map. The map contains 24-bit wide data words for each ADC (readable as 8-bit registers), as well as five writable control registers to program amplifier gain, oversampling, phase, resolution, dithering, shutdown, Reset and communication features. Communication is largely simplified with various continuous read modes that can be accessed through the serial interface and with a separate data ready pin that can directly be connected to a microcontroller's IRQ input.

Because of the complexity of and comprehensive options available on the AFE, a detailed explanation of all of its functional elements is not provided in this chapter. These are described in [Section Appendix B: "Dual-Channel, 24-Bit AFE Reference"](#). This chapter explains the important points of configuring and using the AFE in a PIC18F8XJ72 based application. Direct links to relevant information in the AFE reference are provided throughout the chapter for the reader's convenience.

**FIGURE 22-1: DUAL-CHANNEL ANALOG FRONT END FUNCTIONAL DIAGRAM**



# PIC18F87J72

---

## 22.1 Functional Overview

While it is convenient to think of the dual-channel AFE as a high-precision ADC, there are actually many more components involved. The main components are described below. The dual-channel AFE reference provides more in-depth information on each.

### 22.1.1 DELTA-SIGMA ADC ARCHITECTURE

Each Delta-Sigma ADC is an oversampling converter that incorporates a built-in modulator which is digitizing the quantity of charge integrated by the modulator loop. The quantizer is the block that is performing the analog-to-digital conversion. The quantizer is typically 1-bit, or a simple comparator, which helps to maintain the linearity performance of the ADC (the DAC structure is, in this case, inherently linear).

Multi-bit quantizers help to lower the quantization error (the error fed back in the loop can be very large with 1-bit quantizers) without changing the order of the modulator or the OSR which leads to better SNR figures. However, typically, the linearity of such architectures is more difficult to achieve since the DAC is no more simple to realize and its linearity limits the THD of such ADCs.

The 5-level quantizer is a Flash ADC composed of 4 comparators arranged with equally spaced thresholds and a thermometer coding. The AFE also includes proprietary 5-level DAC architecture that is inherently linear for improved THD figures.

The resulting channel data is either a 16-bit or 24-bit word, presented in 23-bit or 15-bit plus sign, two's complement format and is MSb (left) justified.

### 22.1.2 ANALOG INPUTS (CHn+/-)

The analog inputs can be connected directly to current and voltage transducers. Each input pin is protected by specialized ESD structures that are certified to pass 7 kV HBM and 400V MM contact charge. These structures allow bipolar  $\pm 6V$  continuous voltage with respect to SAVss, to be present at their inputs without the risk of permanent damage.

### 22.1.3 PROGRAMMABLE GAIN AMPLIFIERS (PGA)

The two Programmable Gain Amplifiers (PGAs) reside at the front-end of each Delta-Sigma ADC. They have two functions: translate the common-mode of the input from SAVss to an internal level between SAVss and SAVDD, and amplify the input differential signal. The translation of the common-mode does not change the differential signal, but recenters the common-mode so that the input signal can be properly amplified.

The PGA block can be used to amplify very low signals, but the differential input range of the Delta-Sigma modulator must not be exceeded.

### 22.1.4 SINC<sup>3</sup> FILTER

Both ADCs include a decimation filter that is a third-order sinc (or notch) filter. This filter processes the multi-bit stream into either 16-bit or 24-bit words, depending on the configuration chosen. The settling time of the filter is three DMCLK periods. The resolution achievable at the output of the sinc filter (the output of the ADC) is dependent on the oversampling ratio selected.

#### 22.1.4.1 Internal Voltage Reference

The AFE contains an internal voltage reference source specially designed to minimize drift over temperature. This internal VREF supplies reference voltage to both channels. The typical value of this voltage reference is  $2.37V \pm 2\%$ . The internal reference has a very low typical temperature coefficient of  $\pm 12$  ppm/ $^{\circ}C$ , allowing the output codes to have minimal variation with respect to temperature since they are proportional to  $(1/VREF)$ . The output pin for the internal voltage reference is REFIN+/OUT.

Optionally, the AFE can be configured to use an external voltage reference supplied on the REFIN+ and REFIN- pins.

#### 22.1.5 PHASE DELAY BLOCK

The AFE incorporates a phase delay generator which ensures that the two ADCs are converting the inputs with a fixed delay between them. The two ADCs are synchronously sampling but the averaging of modulator outputs is delayed, so that the SINC filter outputs (thus, the ADC outputs) show a fixed phase delay, configured by the PHASE register.

#### 22.1.6 INTERNAL AFE CLOCK

The AFE uses an external clock signal to operate its internal digital logic. The AFE includes a clock generation chain of back-to-back dividers to produce a range of sampling frequencies.

#### 22.1.7 SERIAL INTERFACE

The AFE uses an SPI-compatible slave serial interface. Its operation is discussed in [Section 22.3 "Serial Interface"](#).

## 22.2 AFE Register Map

The dual-channel AFE uses its own internal registers for data and control. This memory is not mapped to the microcontroller's SFR space, but is accessed through the AFE's serial interface. The memory space is divided into eight registers:

- Two 24-bit registers, one for the data of each ADC
- Five 8-bit control registers
- One reserved 8-bit register address

Although the data registers are 24 bits wide, they may be directly addressed as three different 8-bit registers. The complete memory map is listed in [Table 22-1](#).

All registers are fully described in [Section B.6 “Internal Registers”](#) of the AFE reference.

Registers may be read singly in a single read operation; continuously, as part of a group of registers; or continuously, by type (i.e., data registers vs. control registers). The type of read operation is handled through the AFE's serial interface by selecting the type of read operation. The grouping of registers is shown in [Table 22-2](#). A complete description of the different read operations and how to implement them is described in [Section B.5.3 “Reading from the Device”](#) of the AFE reference.

**TABLE 22-1: AFE REGISTER MAP**

Address	Name	Bits	R/W	Description
00h	DATA_CH0	24	R	Channel 0 ADC Data <23:0>, MSB First
03h	DATA_CH1	24	R	Channel 1 ADC Data <23:0>, MSB First
06h	Reserved	8	—	Reserved; ignore reads, do not write
07h	PHASE	8	R/W	Phase Delay Configuration Register
08h	GAIN	8	R/W	Gain Configuration Register
09h	STATUS/COM	8	R/W	Status/Communication Register
0Ah	CONFIG1	8	R/W	Configuration Register 1
0Bh	CONFIG2	8	R/W	Configuration Register 2

**TABLE 22-2: REGISTER MAP GROUPING FOR CONTINUOUS READ MODES**

Function	Address	READ<1:0>		
		“01”	“10”	“11”
DATA_CH0	00h	Group	Type	Loop Entire Register Map
	01h			
	02h			
DATA_CH1	03h	Group	Type	
	04h			
	05h			
PHASE	07h	Group	Type	
GAIN	08h			
STATUS/COM	09h	Group	Type	
CONFIG1	0Ah			
CONFIG2	0Bh			

# PIC18F87J72

## 22.3 Serial Interface

### 22.3.1 OVERVIEW

All communication with the dual-channel AFE is handled through its serial interface; this includes the exchange of data with the PIC18F8XJ72 device itself. This arrangement allows the AFE to direct data with other microcontrollers on an SPI bus in complex applications, and work cooperatively with other SPI enabled analog devices.

The serial interface is an SPI-compatible slave interface, compatible with SPI modes, 0,0 and 1,1. Data is clocked *out* of the AFE on the *falling* edge of SCKA and, clocked *into* the device on the *rising* edge of SCKA. In these modes, SCKA can Idle either high or low.

A complete discussion of the serial interface is provided in [Section B.5 “Serial Interface Description”](#) of the AFE Reference.

### 22.3.2 CONTROL BYTE

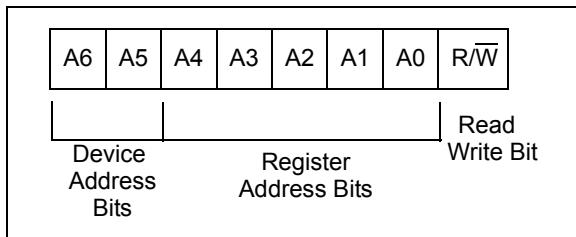
The first byte transmitted to the AFE is always a control byte. This byte is composed of three fields ([Figure 22-2](#)):

- Two address bits (A<6:5>, the MSBs)
- Five register address bits (A<4:0>)
- One Read/Write bit (R/W, the LSbs)

The AFE interface is device-addressable (through A<6:5>), so that multiple devices can be present on the same SPI bus with no data bus contention. This functionality allows external SPI Master devices on the bus, such as another microcontroller, to read and share data. It also enables three-phase power metering systems containing two additional analog front end devices, controlled by a single SPI bus (single CS, SCK, SDI and SDO pins).

The SPI device address bits of the PIC18F87J72 interface are always '00'; they cannot be changed.

**FIGURE 22-2: CONTROL BYTE**



A read on undefined addresses gives an output of all zeros on the first and all subsequent transmitted bytes. Writing to an undefined address has no effect and does not increment the address counter either.

### 22.3.3 READING FROM THE DEVICE

The first data byte read is the one defined by the address given in the control byte. After this first byte is transmitted, if the CSA pin is held low, the communication continues and the address of the next transmitted byte is determined by the configuration of the interface, set by the read bits in the STATUS/COM register.

### 22.3.4 WRITING TO THE DEVICE

The first data byte written is the one defined by the address given in the control byte. The write communication automatically increments the address for subsequent bytes.

The address of the next transmitted byte within the same communication (CSA stays low) is the next address defined on the register map. At the end of the register map, the address loops to the beginning of the register map. Writing a non-writable register has no effect.

The SDOA pin remains in a high-impedance state during a write communication.

### 22.3.5 CONTINUOUS COMMUNICATION AND LOOPING ON ADDRESS SETS

If the user wishes to read back one or both of the ADC channels continuously, the internal address counter of the AFE can be set to loop on specific register sets. This method also makes it possible to continuously read specific register groups, one of the register types or all of the registers.

In each case, one control byte on SDIA starts the communication. The part stays within the same loop until CSA returns high.

Continuous communication is described in more detail in [Section B.5.7 “Continuous Communication, Looping On Address Sets”](#) of the AFE Reference.

### 22.3.6 DATA READY PIN ( $\overline{DR}$ )

In addition to the standard SPI interface pins (SDIA, SDOA, SCKA and CSA), the AFE provides an additional Data Ready ( $\overline{DR}$ ) signal. This signifies to an external device when conversion data is available. The  $\overline{DR}$  signal, available on the pin of the same name, is an active-low pulse at the end of a channel conversion, with a period that is equal to the DRCLK clock period and with a width equal to one DMCLK period.

The  $\overline{DR}$  pin can be configured to operate in different modes that are defined by the availability of conversion data on the ADC channels. The various Data Ready modes and configuration options for the  $\overline{DR}$  pin are described in [Section B.5.9 “Data Ready Pin \(DR\)”](#) of the AFE Reference.

## 22.4 AFE Connections

The dual-channel AFE has multiple data and power connections that are independent of the digital side of the microcontroller. These connections are required to use the AFE, and are in addition to the connection and layout connections provided in [Section 2.0 “Guidelines for Getting Started with PIC18FJ Microcontrollers”](#).

All of the connections required for proper operation of the AFE are shown in [Figure 22-3](#).

### 22.4.1 VOLTAGE AND GROUND CONNECTIONS

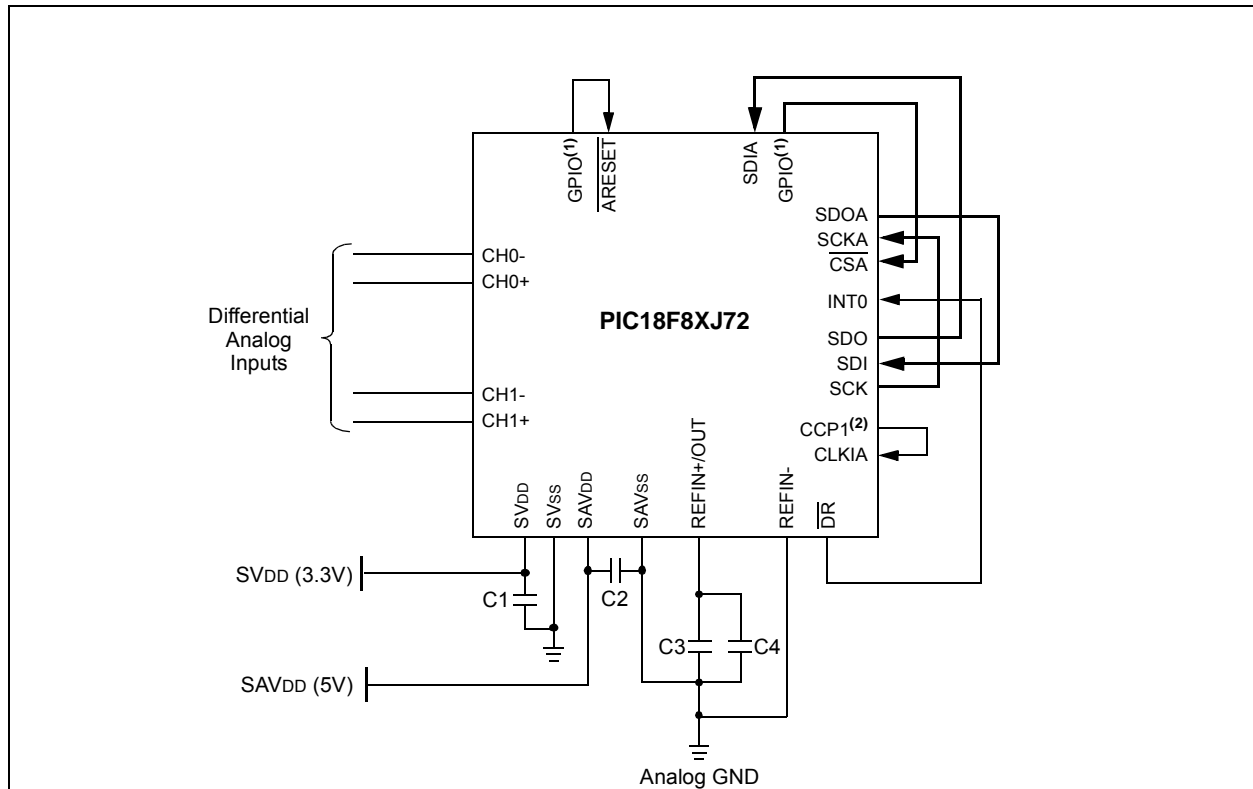
The AFE has independent voltage supply requirements that differ from the rest of the microcontroller. Digital circuits are supplied through the  $SV_{DD}$  pin, which requires a voltage of 2.7V to 5.5V. Typically,  $SV_{DD}$  can be tied to 3.3V, the same as the  $V_{DD}$  and  $AV_{DD}$  pins. Analog circuits are separately supplied through the

$SAV_{DD}$  pin, which requires a voltage of 4.5V to 5.5V ( $5V \pm 10\%$ ). Independent ground returns are provided through the  $SV_{SS}$  and  $SAV_{SS}$  pins, respectively.

As with the microcontroller's  $V_{DD}/V_{SS}$  and  $AV_{DD}/AV_{SS}$  pins, bypass capacitors are required on the AFE power and return pin pairs. Requirements for these capacitors are identical to those for the  $V_{DD}/V_{SS}$  and  $AV_{DD}/AV_{SS}$  pins.

It is recommended that designs using PIC18F87J72 family devices incorporate a separate ground return path for analog circuits.  $SAV_{SS}$ , as well as other AFE analog pins (e.g.,  $REFIN^-$ ) that require grounding, should be tied to this analog return.  $SV_{SS}$  can be tied to the digital ground, along with  $V_{SS}$  and  $AV_{SS}$ . The analog and digital grounds may be tied to a single point at the power source.

**FIGURE 22-3: REQUIRED CONNECTIONS FOR AFE OPERATION**



**Key (all values are recommendations):**

C1 and C2: 0.1  $\mu F$ , 20V ceramic

C3 and C4: 100 nF, 20V ceramic.

**Bold lines** show SPI connections.

**Note 1:** Any available I/O pins may be used to control  $\overline{ARESET}$  and  $\overline{CSA}$ . The software examples discussed in this chapter use RD0 and RD7, respectively.

**Note 2:** The software examples discussed in this chapter use CCP1 to generate the AFE clock source. Other clock sources may be used, as required.

# PIC18F87J72

## 22.4.2 SERIAL INTERFACE CONNECTIONS

The AFE uses its own dedicated Serial Peripheral Interface (SPI) to both send output data from its A/D Converters, and send and receive control information. The interface allows the AFE to operate directly with other microcontrollers and analog peripherals that use SPI on a common serial bus.

To use the interface, the following connections are required between the AFE and the MSSP module:

- from SDO (RC5) to SDIA
- from SDI (RC4) to SDOA
- from SCK (RC3) to SCKA

In addition, the AFE requires a chip select signal on the CSA pin (active-low) to function properly. The chip select signal can be supplied by any available I/O pin.

## 22.4.3 OTHER INTERFACE CONNECTIONS

In addition to the SPI connections, the AFE requires three other digital signals for proper control:

- the Data Ready ( $\overline{DR}$ ) output, asserted low to signal that a conversion has been completed and is ready to be transferred;
- a module Reset ( $\overline{ARESET}$ ), asserted low to independently force the AFE into a POR event; and
- a clock for the AFE's digital circuits, supplied on the CLKIA pin.

To use the Data Ready, tie the  $\overline{DR}$  pin to an external interrupt pin, such as INT0. Asserting  $\overline{DR}$  will cause an interrupt, the ISR for which can be used to read the AFE's data through the SPI. Note that whatever interrupt trigger is used, it must be properly configured to trigger when the pin is asserted low.

For the Reset input, use an available I/O pin to drive  $\overline{ARESET}$  low when needed.

For the AFE clock signal, any suitable clock signal in the proper frequency range (1 MHz to 5 MHz) can be used. One convenient and low pin count method is to use a CCP module in PWM mode to generate an appropriate clock, then connect the module's output pin to CLKIA.

## 22.4.4 ANALOG INPUTS

The analog signals to be converted to digital values are connected to the pins of CH0 and/or CH1. Each channel has inverting and non-inverting inputs (CHn- and CHn+, respectively), and is fully differential. Limits and absolute maximums for the inputs are described in [Section 29.0 "Electrical Characteristics"](#).

The REFIN+/OUT and REFIN- pins are used to supply an external voltage reference to the AFE; the REFIN+/OUT pin can also be configured to provide voltage generated by the AFE's internal voltage reference. If the internal voltage reference is enabled, bypass capacitors to analog ground are recommended for the REFIN+/OUT pin. The REFIN- pin should be directly connected to analog ground (as shown in [Figure 22-3](#)).

## 22.5 Using the AFE

To configure the AFE and read A/D conversion data, follow this sequence:

1. Initialize the MSSP module:
  - a) Configure for SPI Master mode, in either SPI mode 0,0 (CKP = 0, CKE = 1) or mode 1,1 (CKP = 1, CKE = 0).
  - b) Configure TRISC for SCK and SDO as outputs, and SDI as input.
2. Reset the AFE by pulling  $\overline{ARESET}$  low.
3. Pull CSA high.
4. Disable the chip select signals of all the devices connected to the same SPI bus.
5. Pull CSA low, then write the register address with command (read or write selection) to the AFE through the SPI.

As long as CSA is enabled, the address will increment automatically after each SPI transfer is completed. After sending the address and command, the registers of the AFE can be written or read.

Disable CSA after read or write to a set of AFE registers.

**Note:** The first byte sent to the AFE upon initialization must always be a control byte. See [Section B.5 "Serial Interface Description"](#) for more information.

6. When the  $\overline{DR}$  signal is asserted, signalling that an A/D conversion is complete, use an interrupt routine to read the data from one or both channels. The overall method is similar to that for reading other AFE registers over the SPI, described in step 5.

Note that SPI operations to read or write the AFE's registers can be performed even without providing CLKIA to the AFE. The CLKIA signal is required to perform A/D conversions and make the Data Ready ( $\overline{DR}$ ) signal available after conversions are done.



Example 22-1 provides a general outline for implementing a driver routine for the AFE. Example 22-2 through Example 22-5 show the details for each step.

The example shown here assumes the following loopback connections:

- RC4 (SDI) to SDOA
- RC5 (SDO) to SDIA
- RC3 (SCK) to SCKA
- RD0 to  $\overline{\text{ARESET}}$
- RD7 to  $\overline{\text{CSA}}$
- RC2 (CCP1) to CLKIA
- RB0 (INT0) to  $\overline{\text{DR}}$

Aside from the SPI, which is determined by the microcontroller's single MSSP module, the other connections may change based on the particular application's requirements. For example, the AFE clock on CLKIA is generated from the PWM of CCP1 in this demonstration; other clock sources may be available. Users should modify the individual code segments accordingly.

## EXAMPLE 22-1: OVERALL STRUCTURE FOR USING THE AFE

```

////////////////////////////////////////////////////////////////////////////////////////////////////////////////////////////////
// Outline of a typical driver routine for the dual-channel AFE.
////////////////////////////////////////////////////////////////////////////////////////////////////////////////////////////////

#include "p18F87J72.h"

void main(void)
{

////////////////////////////////////////////////////////////////////////////////////////////////////////////////////////////////
// STEP 1: Initialize MSSP (Example 22-2)
////////////////////////////////////////////////////////////////////////////////////////////////////////////////////////////////

////////////////////////////////////////////////////////////////////////////////////////////////////////////////////////////////
// STEP 2: Issue Reset to AFE (Example 22-2)
////////////////////////////////////////////////////////////////////////////////////////////////////////////////////////////////

////////////////////////////////////////////////////////////////////////////////////////////////////////////////////////////////
// STEPS 3: Disable all Chip Selects on all SPI devices (Example 22-2)
////////////////////////////////////////////////////////////////////////////////////////////////////////////////////////////////

////////////////////////////////////////////////////////////////////////////////////////////////////////////////////////////////
// STEP 4: Write to AFE registers; read back (optionally) to confirm settings (Example 22-4)
////////////////////////////////////////////////////////////////////////////////////////////////////////////////////////////////

////////////////////////////////////////////////////////////////////////////////////////////////////////////////////////////////
// STEP 5: Configure CCP1 to serve as AFE clock source (Example 22-3)
////////////////////////////////////////////////////////////////////////////////////////////////////////////////////////////////

////////////////////////////////////////////////////////////////////////////////////////////////////////////////////////////////
//STEP 6: Configure Interrupt INT0 for use with DR pin (Example 22-3)
////////////////////////////////////////////////////////////////////////////////////////////////////////////////////////////////

while(1);
}

////////////////////////////////////////////////////////////////////////////////////////////////////////////////////////////////
//STEP 7: ISR for reading AFE data (Example 22-5)
////////////////////////////////////////////////////////////////////////////////////////////////////////////////////////////////

```

# PIC18F87J72

## EXAMPLE 22-2: INITIALIZING THE MSSP MODULE

```
////////////////////////////////////
// STEP 1: Initialize the MSSP in SPI Master mode to access the AFE
// Connections: SCK--SCKA, SDI--SDOA, SDO--SDIA
////////////////////////////////////

SSPCON1bits.CKP = 1;    // SPI mode 1,1: idle state for SCK is high,
SSPCON1bits.CKE = 0;    // data transmitted on transition from idle to active state
// SSPCON1bits.CKP = 0;    // If SPI mode 0,0 is used instead, SCK idle state is low,
// SSPCON1bits.CKE = 1;    // data transmitted on transition from active to idle state
SSPCON1bits.SSPEN = 1;  // Enable SPI
TRISCBits.TRISC3 = 0;   // define SCK pin as output
TRISCBits.TRISC4 = 1;   // define SDI pin as input
TRISCBits.TRISC5 = 0;   // define SDO pin as output

////////////////////////////////////
// STEP 2: Issue Reset to AFE. ARESET pin is connected to RD0 in this example
////////////////////////////////////

LATDbits.LATD0 = 0;
TRISDbits.TRISD0=0;    // Put the Delta Sigma ADC module in reset
LATDbits.LATD0 = 1;    // Release the Delta Sigma ADC module from reset

////////////////////////////////////
// STEP 3:
// Disable all chip selects for all devices connected to SPI, including chip select
// for the AFE. CSA is connected to RD7 in this example
////////////////////////////////////

TRISDbits.TRISD7=0;
LATDbits.LATD7=1;
```

## EXAMPLE 22-3: AFE CLOCK SOURCE AND INTERRUPT CONFIGURATION

```
////////////////////////////////////
// STEP 5: Set up Clock to AFE.
// Connections: In this example CLKIA is connected to CCP1.
////////////////////////////////////

CCP1CON |= 0b00001100;  // ccpxm3:ccpxm0 11xx=pwm mode
CCPR1L=0x01;           // 50% Duty Cycle Clock
TRISCBits.TRISC2 = 0;  // Make RC2 Output; RC2 is connected to CLKIA of AFE
T2CONbits.TMR2ON = 0;  // STOP TIMER2 registers to POR state
PR2 = 0x01;            // Set period
T2CONbits.TMR2ON = 1;  // Turn on PWM1

////////////////////////////////////
// STEP 6: Interrupt Configuration
// DR output of AFE can be used as interrupt. It can be connected to any external interrupt,
// like INT0. It can be declared as low or high priority interrupt.
// This example configures INT0 (connected to DR)as a high-priority interrupt.
////////////////////////////////////

RCONbits.IPEN=1;       //Priority Interrupt
INTCON2bits.RBPU=0;    //Enable INT0 pull-up; required
INTCON2bits.INTEDG0=0; //Falling edge select; DR is active low pulse
INTCONbits.GIEH = 1;   //Enable high priority interrupts
INTCONbits.INT0IE = 1; //Enable INT0 interrupt
```

## EXAMPLE 22-4: WRITING AND READING AFE REGISTERS THROUGH THE MSSP

```

////////////////////////////////////
// STEP 4: Write to AFE registers
// Initialize the AFE by writing to PHASE, GAIN, STATUS, CONFIG1 and CONFIG2 registers.
// Below is an example. The registers can be programmed with values as required
// by the application.
////////////////////////////////////

LATDbits.LATD7=0;           //Chipselect enable for Delta Sigma ADC
if (SSPSTATbits.BF==1)
    Dummy_Read=SSPBUF;
SSPBUF = 0x0E;              //Address and Write command for Gain Register
                             // A6-A5--->00;A4-A0---->0x07;R/W---0 for write

while(!SSPSTATbits.BF);
Dummy_Read=SSPBUF;         //Dummy read to clear Buffer Full Status bit
SSPBUF =0x00;              //PHASE Register: No Delay
while(!SSPSTATbits.BF);
Dummy_Read=SSPBUF;
SSPBUF =0x04;              //Address automatically incremented GAIN Register
                             //CH1 gain 16, CH0 gain 1, No Boost

while(!SSPSTATbits.BF);
Dummy_Read=SSPBUF;
SSPBUF = 0xA0;             //Address automatically incremented STATUS Register
                             //Default values

while(!SSPSTATbits.BF);
Dummy_Read=SSPBUF;
SSPBUF = 0x10;             //Address automatically incrementedData for CONFIG1 Register
                             //No Dither, Other values are default

while(!SSPSTATbits.BF);
Dummy_Read=SSPBUF;
SSPBUF = 0x01;             //Address automatically incremented Data for CONFIG2 Register
                             //CLKEXT bit should be always programmed to 1

while(!SSPSTATbits.BF);
Dummy_Read=SSPBUF;
LATDbits.LATD7=1;         //Disable chip select after read/write of each set of registers

////////////////////////////////////
// Read from AFE registers to verify; this step is optional and does not affect AFE Operation.
// As an example, only GAIN, STATUS, CONFIG1 and CONFIG2 are read.
////////////////////////////////////

LATDbits.LATD7=0;           //Chip select enable for AFE
SSPBUF = 0x11;             //Address and Read command for Gain Register
                             // A6-A5--->00;A4-A0---->0x08;R/W---1 for read

while(!SSPSTATbits.BF);
Dummy_Read=SSPBUF;         //Dummy read to clear Buffer Full Status bit
SSPBUF =0x00;
while(!SSPSTATbits.BF);
D_S_ADC_data1=SSPBUF;      //Data from GAIN Register
SSPBUF =0x00;
while(!SSPSTATbits.BF);
D_S_ADC_data2=SSPBUF;      //Data from STATUS Register, Address automatically incremented
SSPBUF =0x00;
while(!SSPSTATbits.BF);
D_S_ADC_data3=SSPBUF;      //Data from CONFIG1 Register, Address automatically incremented
SSPBUF = 0x00;
while(!SSPSTATbits.BF);
D_S_ADC_data4=SSPBUF;      //Data from CONFIG2 Register, Address automatically incremented
LATDbits.LATD7=1;         //Disable chip select after read/write of each set of registers

```

# PIC18F87J72

## EXAMPLE 22-5: READING DATA FROM AFE DURING INTERRUPT

```
////////////////////////////////////
// STEP 7: Reading AFE results in Interrupt Routine.
// ADC is configured in 16-bit result mode, thus 16-bit result of each Channel can be read.
// In this example DR is connected to INT0; after each conversion, DR issues interrupt to INT0.
// INT0 is configured as high priority interrupt
////////////////////////////////////

#pragma interrupt High_isr_routine
void High_isr_routine(void)
{
char   D_S_ADC_data1=0,D_S_ADC_data2=0,D_S_ADC_data3=0,D_S_ADC_data4=0,Dummy_Read=0;
    if((INTCONbits.INT0IF)&&(INTCONbits.INT0IE))
    {
        // Disable all Chip selects of other devices connected to SPI
        LATDbits.LATD7=0;           //Chip select enable for Delta Sigma ADC
        SSP1BUF = 0x01;           //Address and Read command for Channel0 result MSB register
        while(!SSPSTATbits.BF);
        Dummy_Read=SSPBUF;       //Dummy read to clear Buffer Full Status bit
        SSPBUF =0x00;
        while(!SSPSTATbits.BF);
        D_S_ADC_data1=SSPBUF;     //Data from Channel0 MSB
        SSPBUF = 0x00;
        while(!SSPSTATbits.BF);
        D_S_ADC_data2=SSPBUF;     //Data from Channel0 LSB, Address automatically incremented
        SSPBUF = 0x00;
        while(!SSPSTATbits.BF);
        D_S_ADC_data3=SSPBUF;     //Data from Channel1 MSB, Address automatically incremented
        SSPBUF = 0x00;
        while(!SSPSTATbits.BF);
        D_S_ADC_data4=SSPBUF;     //Data from Channel1 LSB, Address automatically incremented
        LATDbits.LATD7=1;       //Disable chip select after read/write of registers

        INTCONbits.INT0IF=0;     //Clear INT0IF for next interrupt
    }
}

#pragma code High_isr=0x08
void High_ISR(void)
{
    _asm goto High_isr_routine _endasm
}
}
```

## 23.0 COMPARATOR MODULE

The analog comparator module contains two comparators that can be configured in a variety of ways. The inputs can be selected from the analog inputs multiplexed with pins, RF1 through RF6, as well as the on-chip voltage reference (see [Section 24.0 “Comparator Voltage Reference Module”](#)). The digital outputs (normal or inverted) are available at the pin level and can also be read through the control register.

The CMCON register ([Register 23-1](#)) selects the comparator input and output configuration. Block diagrams of the various comparator configurations are shown in [Figure 23-1](#).

**REGISTER 23-1: CMCON: COMPARATOR MODULE CONTROL REGISTER**

R-0	R-0	R/W-0	R/W-0	R/W-0	R/W-1	R/W-1	R/W-1
C2OUT	C1OUT	C2INV	C1INV	CIS	CM2	CM1	CM0
bit 7							bit 0

Legend:

R = Readable bit  
-n = Value at POR

W = Writable bit  
'1' = Bit is set

U = Unimplemented bit, read as '0'  
'0' = Bit is cleared

x = Bit is unknown

bit 7 **C2OUT**: Comparator 2 Output bit

When C2INV = 0:

1 = C2 VIN+ > C2 VIN-  
0 = C2 VIN+ < C2 VIN-

When C2INV = 1:

1 = C2 VIN+ < C2 VIN-  
0 = C2 VIN+ > C2 VIN-

bit 6 **C1OUT**: Comparator 1 Output bit

When C1INV = 0:

1 = C1 VIN+ > C1 VIN-  
0 = C1 VIN+ < C1 VIN-

When C1INV = 1:

1 = C1 VIN+ < C1 VIN-  
0 = C1 VIN+ > C1 VIN-

bit 5 **C2INV**: Comparator 2 Output Inversion bit

1 = C2 output is inverted  
0 = C2 output is not inverted

bit 4 **C1INV**: Comparator 1 Output Inversion bit

1 = C1 output is inverted  
0 = C1 output is not inverted

bit 3 **CIS**: Comparator Input Switch bit

When CM<2:0> = 110:

1 = C1 VIN- connects to RF5/AN10/CVREF/SEG23/C1INB  
C2 VIN- connects to RF3/AN8/SEG21/C2INB  
0 = C1 VIN- connects to RF6/AN11/SEG24/C1INA  
C2 VIN- connects to RF4/AN9/SEG22/C2INA

bit 2-0 **CM<2:0>**: Comparator Mode bits

[Figure 23-1](#) shows the Comparator modes and the CM<2:0> bit settings.

# PIC18F87J72

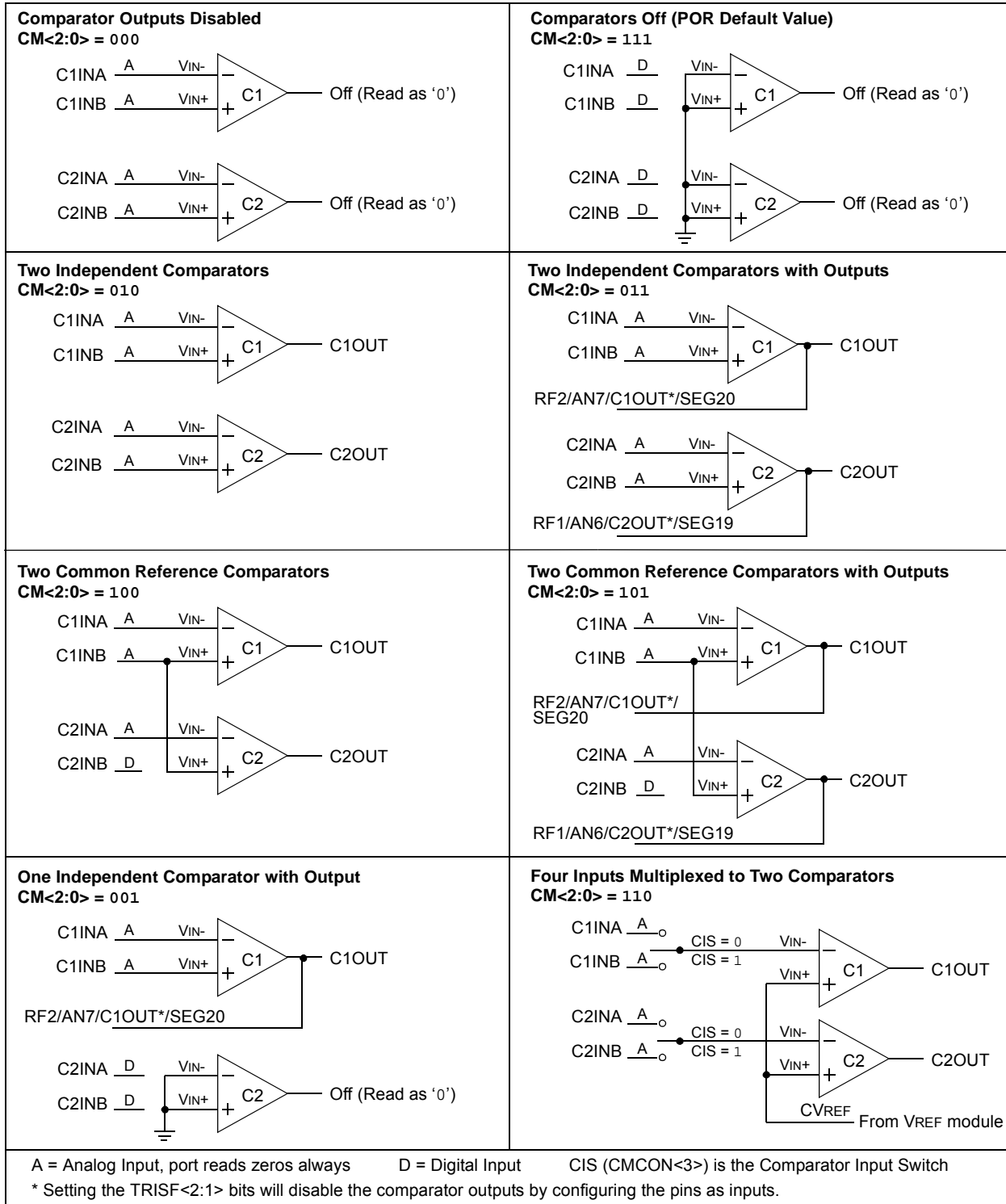
## 23.1 Comparator Configuration

There are eight modes of operation for the comparators, shown in Figure 23-1. The CM<2:0> bits of the CMCON register are used to select these modes. The TRISF register controls the data direction of the comparator pins for each mode. If the Comparator

mode is changed, the comparator output level may not be valid for the specified mode change delay shown in Section 29.0 “Electrical Characteristics”.

**Note:** Comparator interrupts should be disabled during a Comparator mode change; otherwise, a false interrupt may occur.

**FIGURE 23-1: COMPARATOR I/O OPERATING MODES**



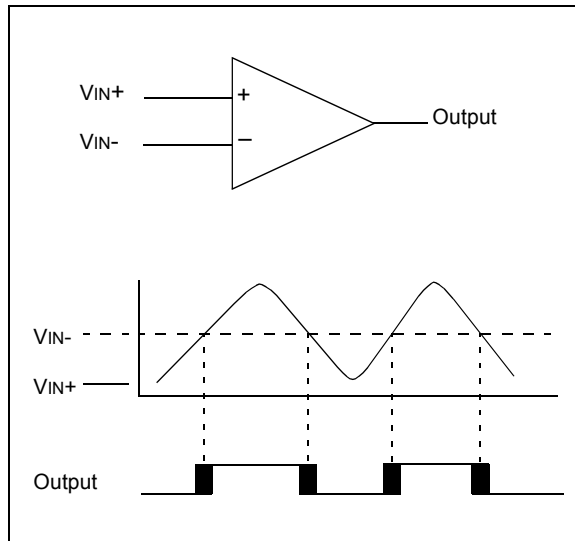
## 23.2 Comparator Operation

A single comparator is shown in [Figure 23-2](#), along with the relationship between the analog input levels and the digital output. When the analog input at  $V_{IN+}$  is less than the analog input  $V_{IN-}$ , the output of the comparator is a digital low level. When the analog input at  $V_{IN+}$  is greater than the analog input  $V_{IN-}$ , the output of the comparator is a digital high level. The shaded areas of the output of the comparator in [Figure 23-2](#) represent the uncertainty due to input offsets and response time.

## 23.3 Comparator Reference

Depending on the comparator operating mode, either an external or internal voltage reference may be used. The analog signal present at  $V_{IN-}$  is compared to the signal at  $V_{IN+}$  and the digital output of the comparator is adjusted accordingly ([Figure 23-2](#)).

**FIGURE 23-2: SINGLE COMPARATOR**



### 23.3.1 EXTERNAL REFERENCE SIGNAL

When external voltage references are used, the comparator module can be configured to have the comparators operate from the same or different reference sources. However, threshold detector applications may require the same reference. The reference signal must be between  $V_{SS}$  and  $V_{DD}$  and can be applied to either pin of the comparator(s).

### 23.3.2 INTERNAL REFERENCE SIGNAL

The comparator module also allows the selection of an internally generated voltage reference from the comparator voltage reference module. This module is described in more detail in [Section 24.0 “Comparator Voltage Reference Module”](#).

The internal reference is only available in the mode where four inputs are multiplexed to two comparators ( $CM<2:0> = 110$ ). In this mode, the internal voltage reference is applied to the  $V_{IN+}$  pin of both comparators.

## 23.4 Comparator Response Time

Response time is the minimum time, after selecting a new reference voltage or input source, before the comparator output has a valid level. If the internal reference is changed, the maximum delay of the internal voltage reference must be considered when using the comparator outputs. Otherwise, the maximum delay of the comparators should be used (see [Section 29.0 “Electrical Characteristics”](#)).

## 23.5 Comparator Outputs

The comparator outputs are read through the CMCON register. These bits are read-only. The comparator outputs may also be directly output to the RF1 and RF2 I/O pins. When enabled, multiplexers in the output path of the RF1 and RF2 pins will switch and the output of each pin will be the unsynchronized output of the comparator. The uncertainty of each of the comparators is related to the input offset voltage and the response time given in the specifications. [Figure 23-3](#) shows the comparator output block diagram.

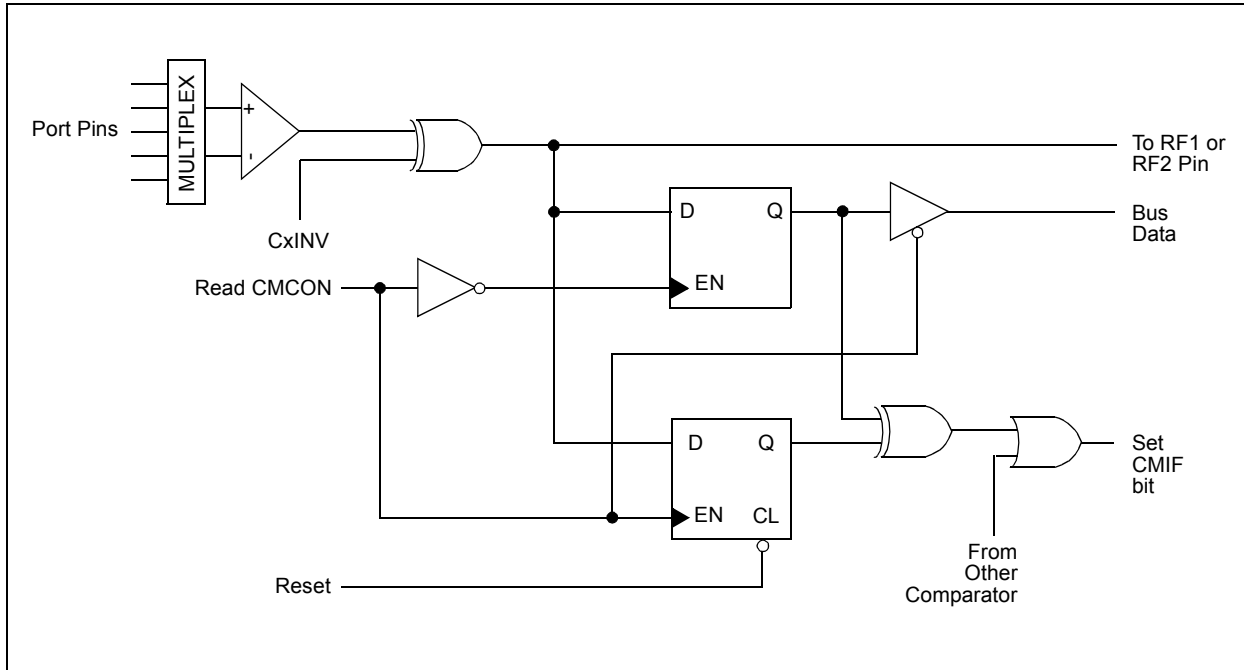
The TRISF bits will still function as an output enable/disable for the RF1 and RF2 pins while in this mode.

The polarity of the comparator outputs can be changed using the C2INV and C1INV bits ( $CMCON<5:4>$ ).

- Note 1:** When reading the PORT register, all pins configured as analog inputs will read as '0'. Pins configured as digital inputs will convert an analog input according to the Schmitt Trigger input specification.
- 2:** Analog levels on any pin defined as a digital input may cause the input buffer to consume more current than is specified.

# PIC18F87J72

**FIGURE 23-3: COMPARATOR OUTPUT BLOCK DIAGRAM**



## 23.6 Comparator Interrupts

The comparator interrupt flag is set whenever there is a change in the output value of either comparator. Software will need to maintain information about the status of the output bits, as read from CMCON<7:6>, to determine the actual change that occurred. The CMIF bit (PIR2<6>) is the Comparator Interrupt Flag. The CMIF bit must be reset by clearing it. Since it is also possible to write a '1' to this register, a simulated interrupt may be initiated.

Both the CMIE bit (PIE2<6>) and the PEIE bit (INTCON<6>) must be set to enable the interrupt. In addition, the GIE bit (INTCON<7>) must also be set. If any of these bits are clear, the interrupt is not enabled, though the CMIF bit will still be set if an interrupt condition occurs.

**Note:** If a change in the CMCON register (C1OUT or C2OUT) should occur when a read operation is being executed (start of the Q2 cycle), then the CMIF (PIR2<6>) interrupt flag may not get set.

The user, in the Interrupt Service Routine, can clear the interrupt in the following manner:

- a) Any read or write of CMCON will end the mismatch condition.
- b) Clear flag bit, CMIF.

A mismatch condition will continue to set flag bit, CMIF. Reading CMCON will end the mismatch condition and allow flag bit, CMIF, to be cleared.

## 23.7 Comparator Operation During Sleep

When a comparator is active and the device is placed in Sleep mode, the comparator remains active and the interrupt is functional, if enabled. This interrupt will wake-up the device from Sleep mode, when enabled. Each operational comparator will consume additional current, as shown in the comparator specifications. To minimize power consumption while in Sleep mode, turn off the comparators (CM<2:0> = 111) before entering Sleep. If the device wakes up from Sleep, the contents of the CMCON register are not affected.

## 23.8 Effects of a Reset

A device Reset forces the CMCON register to its Reset state, causing the comparator modules to be turned off (CM<2:0> = 111). However, the input pins (RF3 through RF6) are configured as analog inputs by default on device Reset. The I/O configuration for these pins is determined by the setting of the PCFG<3:0> bits (ADCON1<3:0>). Therefore, device current is minimized when analog inputs are present at Reset time.

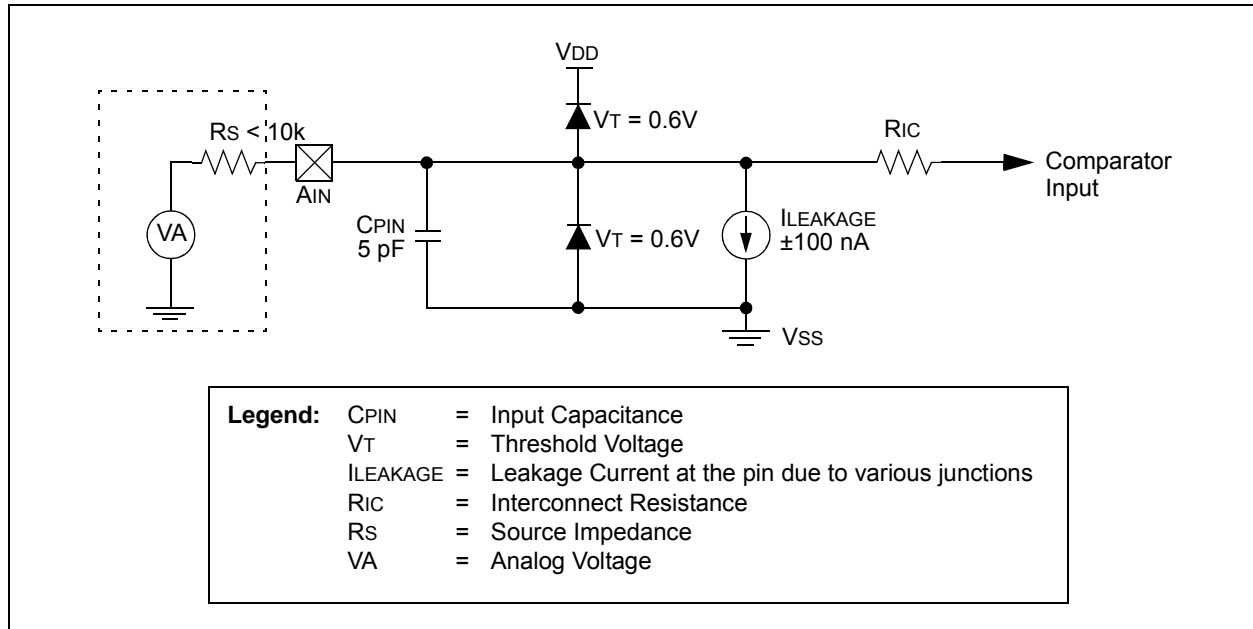


## 23.9 Analog Input Connection Considerations

A simplified circuit for an analog input is shown in Figure 23-4. Since the analog pins are connected to a digital output, they have reverse biased diodes to VDD and VSS. The analog input, therefore, must be between VSS and VDD. If the input voltage deviates from this

range by more than 0.6V in either direction, one of the diodes is forward biased and a latch-up condition may occur. A maximum source impedance of 10 kΩ is recommended for the analog sources. Any external component connected to an analog input pin, such as a capacitor or a Zener diode, should have very little leakage current.

**FIGURE 23-4: COMPARATOR ANALOG INPUT MODEL**



**TABLE 23-1: REGISTERS ASSOCIATED WITH COMPARATOR MODULE**

Name	Bit 7	Bit 6	Bit 5	Bit 4	Bit 3	Bit 2	Bit 1	Bit 0	Reset Values on page
INTCON	GIE/GIEH	PEIE/GIEL	TMR0IE	INT0IE	RBIE	TMR0IF	INT0IF	RBIF	45
PIR2	OSCFIF	CMIF	—	—	BCLIF	LVDIF	TMR3IF	—	48
PIE2	OSCFIE	CMIE	—	—	BCLIE	LVDIE	TMR3IE	—	48
IPR2	OSCFIP	CMIP	—	—	BCLIP	LVDIP	TMR3IP	—	48
CMCON	C2OUT	C1OUT	C2INV	C1INV	CIS	CM2	CM1	CM0	47
CVRCON	CVREN	CVROE	CVRR	CVRSS	CVR3	CVR2	CVR1	CVR0	47
PORTF	RF7	RF6	RF5	RF4	RF3	RF2	RF1	—	48
LATF	LATF7	LATF6	LATF5	LATF4	LATF3	LATF2	LATF1	—	48
TRISF	TRISF7	TRISF6	TRISF5	TRISF4	TRISF3	TRISF2	TRISF1	—	48

Legend: — = unimplemented, read as '0'. Shaded cells are unused by the comparator module.

# PIC18F87J72

## 24.0 COMPARATOR VOLTAGE REFERENCE MODULE

The comparator voltage reference is a 16-tap resistor ladder network that provides a selectable reference voltage. Although its primary purpose is to provide a reference for the analog comparators, it may also be used independently of them.

A block diagram of the module is shown in [Figure 24-1](#). The resistor ladder is segmented to provide two ranges of CVREF values and has a power-down function to conserve power when the reference is not being used. The module's supply reference can be provided from either device VDD/VSS or an external voltage reference.

### 24.1 Configuring the Comparator Voltage Reference

The comparator voltage reference module is controlled through the CVRCON register ([Register 24-1](#)). The comparator voltage reference provides two ranges of output voltage, each with 16 distinct levels.

The range to be used is selected by the CVRR bit (CVRCON<5>). The primary difference between the ranges is the size of the steps selected by the CVREF Selection bits (CVR<3:0>), with one range offering finer resolution. The equations used to calculate the output of the comparator voltage reference are as follows:

$$\text{If CVRR} = 1: \\ \text{CVREF} = ((\text{CVR}\langle 3:0 \rangle) / 24) \times (\text{CVRSRC})$$

$$\text{If CVRR} = 0: \\ \text{CVREF} = (\text{CVRSRC} / 4) + ((\text{CVR}\langle 3:0 \rangle) / 32) \times (\text{CVRSRC})$$

The comparator reference supply voltage can come from either VDD and VSS, or the external VREF+ and VREF- that are multiplexed with RA2 and RA3. The voltage source is selected by the CVRSS bit (CVRCON<4>).

The settling time of the comparator voltage reference must be considered when changing the CVREF output (see [Table](#) in [Section 29.0 "Electrical Characteristics"](#)).

**REGISTER 24-1: CVRCON: COMPARATOR VOLTAGE REFERENCE CONTROL REGISTER**

R/W-0	R/W-0	R/W-0	R/W-0	R/W-0	R/W-0	R/W-0	R/W-0
CVREN	CVROE <sup>(1)</sup>	CVRR	CVRSS	CVR3	CVR2	CVR1	CVR0
bit 7							bit 0

Legend:

R = Readable bit  
-n = Value at POR

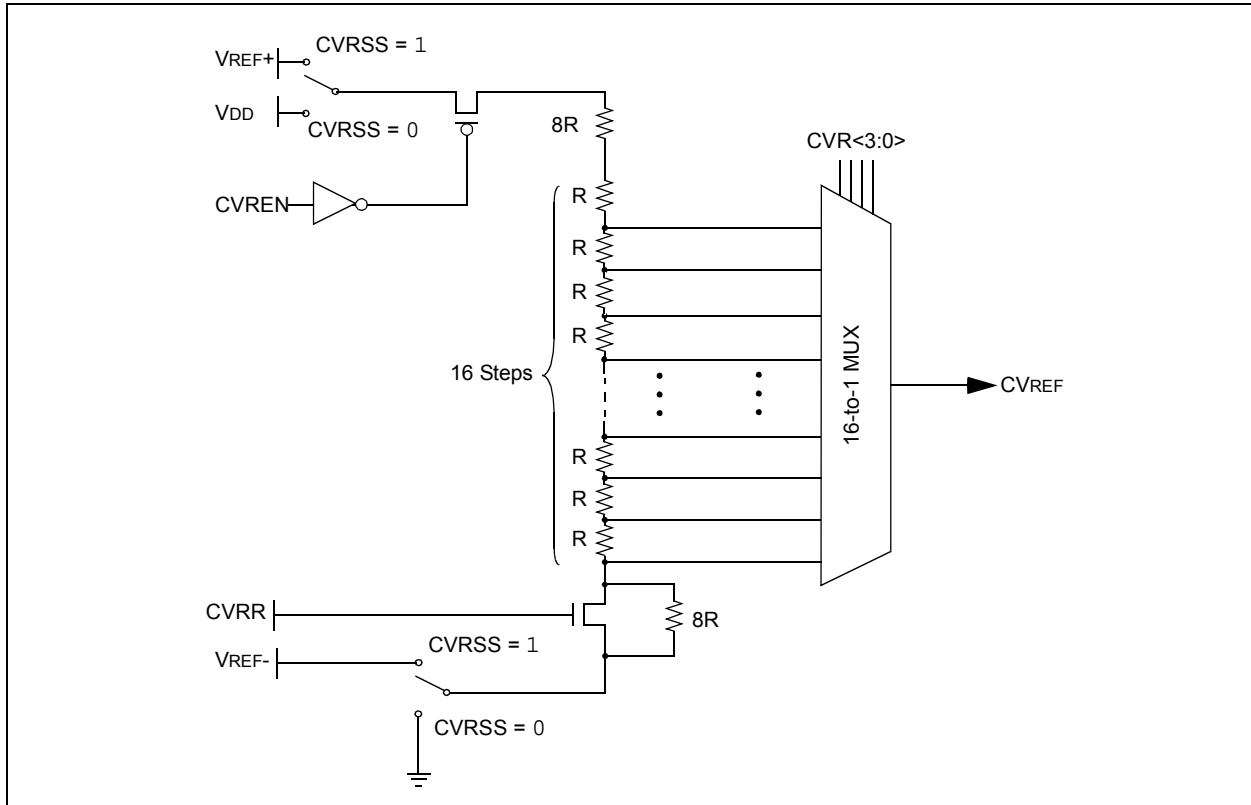
W = Writable bit  
'1' = Bit is set

U = Unimplemented bit, read as '0'  
'0' = Bit is cleared  
x = Bit is unknown

- bit 7      **CVREN:** Comparator Voltage Reference Enable bit  
1 = CVREF circuit powered on  
0 = CVREF circuit powered down
- bit 6      **CVROE:** Comparator VREF Output Enable bit<sup>(1)</sup>  
1 = CVREF voltage level is also output on the RF5/AN10/CVREF/SEG23/C11NB pin  
0 = CVREF voltage is disconnected from the RF5/AN10/CVREF/SEG23/C11NB pin
- bit 5      **CVRR:** Comparator VREF Range Selection bit  
1 = 0 to 0.667 CVRSRC, with CVRSRC/24 step size (low range)  
0 = 0.25 CVRSRC to 0.75 CVRSRC, with CVRSRC/32 step size (high range)
- bit 4      **CVRSS:** Comparator VREF Source Selection bit  
1 = Comparator reference source, CVRSRC = (VREF+) – (VREF-)  
0 = Comparator reference source, CVRSRC = VDD – VSS
- bit 3-0    **CVR<3:0>:** Comparator VREF Value Selection bits ( $0 \leq (\text{CVR}\langle 3:0 \rangle) \leq 15$ )  
When CVRR = 1:  
 $\text{CVREF} = ((\text{CVR}\langle 3:0 \rangle) / 24) \bullet (\text{CVRSRC})$   
When CVRR = 0:  
 $\text{CVREF} = (\text{CVRSRC} / 4) + ((\text{CVR}\langle 3:0 \rangle) / 32) \bullet (\text{CVRSRC})$

**Note 1:** CVROE overrides the TRISF<5> bit setting.

**FIGURE 24-1: COMPARATOR VOLTAGE REFERENCE BLOCK DIAGRAM**



## 24.2 Voltage Reference Accuracy/Error

The full range of voltage reference cannot be realized due to the construction of the module. The transistors on the top and bottom of the resistor ladder network (Figure 24-1) keep  $CVREF$  from approaching the reference source rails. The voltage reference is derived from the reference source; therefore, the  $CVREF$  output changes with fluctuations in that source. The tested absolute accuracy of the voltage reference can be found in Section 29.0 "Electrical Characteristics".

## 24.3 Operation During Sleep

When the device wakes up from Sleep through an interrupt or a Watchdog Timer time-out, the contents of the  $CVRCON$  register are not affected. To minimize current consumption in Sleep mode, the voltage reference should be disabled.

## 24.4 Effects of a Reset

A device Reset disables the voltage reference by clearing bit,  $CVREN$  ( $CVRCON<7>$ ). This Reset also disconnects the reference from the  $RA2$  pin by clearing bit,  $CVROE$  ( $CVRCON<6>$ ) and selects the high-voltage range by clearing bit,  $CVRR$  ( $CVRCON<5>$ ). The  $CVR$  value select bits are also cleared.

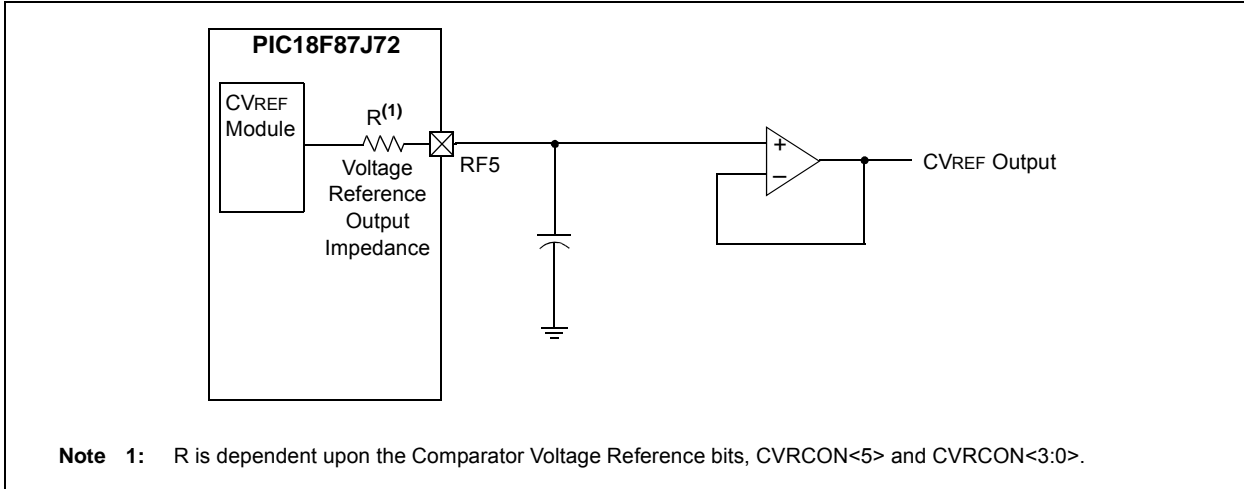
## 24.5 Connection Considerations

The voltage reference module operates independently of the comparator module. The output of the reference generator may be connected to the  $RF5$  pin if the  $CVROE$  bit is set. Enabling the voltage reference output onto  $RA2$  when it is configured as a digital input will increase current consumption. Connecting  $RF5$  as a digital output with  $CVRSS$  enabled will also increase current consumption.

The  $RF5$  pin can be used as a simple D/A output with limited drive capability. Due to the limited current drive capability, a buffer must be used on the voltage reference output for external connections to  $V_{REF}$ . Figure 24-2 shows an example buffering technique.

# PIC18F87J72

**FIGURE 24-2: COMPARATOR VOLTAGE REFERENCE OUTPUT BUFFER EXAMPLE**



**TABLE 24-1: REGISTERS ASSOCIATED WITH COMPARATOR VOLTAGE REFERENCE**

Name	Bit 7	Bit 6	Bit 5	Bit 4	Bit 3	Bit 2	Bit 1	Bit 0	Reset Values on page
CVRCON	CVREN	CVROE	CVRR	CVRSS	CVR3	CVR2	CVR1	CVR0	47
CMCON	C2OUT	C1OUT	C2INV	C1INV	CIS	CM2	CM1	CM0	47
TRISF	TRISF7	TRISF6	TRISF5	TRISF4	TRISF3	TRISF2	TRISF1	—	48

Legend: — = unimplemented, read as '0'. Shaded cells are not used with the comparator voltage reference.

## 25.0 CHARGE TIME MEASUREMENT UNIT (CTMU)

The Charge Time Measurement Unit (CTMU) is a flexible analog module that provides accurate differential time measurement between pulse sources, as well as asynchronous pulse generation. By working with other on-chip analog modules, the CTMU can be used to precisely measure time, measure capacitance, measure relative changes in capacitance or generate output pulses with a specific time delay. The CTMU is ideal for interfacing with capacitive-based sensors.

The module includes the following key features:

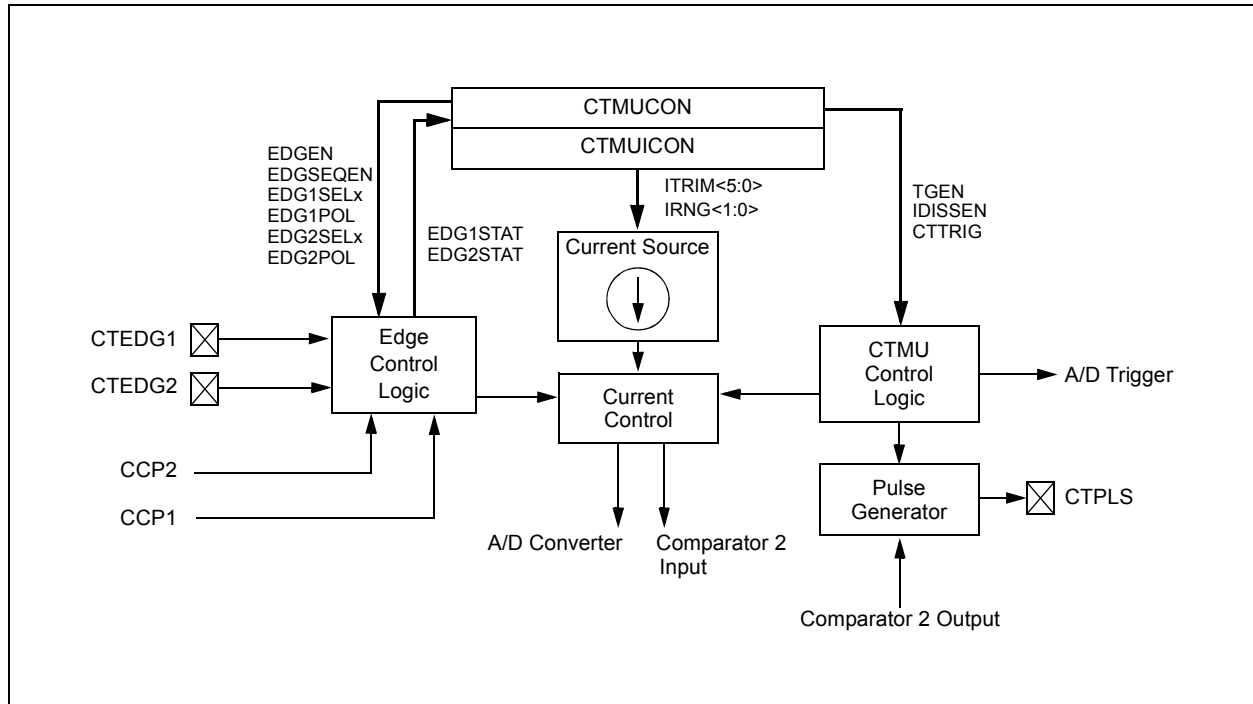
- Up to 13 channels available for capacitive or time measurement input
- On-chip precision current source
- Four-edge input trigger sources
- Polarity control for each edge source

- Control of edge sequence
- Control of response to edges
- Time measurement resolution of 1 nanosecond
- High-precision time measurement
- Time delay of external or internal signal asynchronous to system clock
- Accurate current source suitable for capacitive measurement

The CTMU works in conjunction with the A/D Converter to provide up to 13 channels for time or charge measurement, depending on the specific device and the number of A/D channels available. When configured for time delay, the CTMU is connected to one of the analog comparators. The level-sensitive input edge sources can be selected from four sources: two external inputs or CCP1/CCP2 Special Event Triggers.

Figure 25-1 provides a block diagram of the CTMU.

**FIGURE 25-1: CTMU BLOCK DIAGRAM**



## 25.1 CTMU Operation

The CTMU works by using a fixed current source to charge a circuit. The type of circuit depends on the type of measurement being made. In the case of charge measurement, the current is fixed, and the amount of time the current is applied to the circuit is fixed. The amount of voltage read by the A/D is then a measurement of the capacitance of the circuit. In the case of time measurement, the current, as well as the capacitance of the circuit, is fixed. In this case, the voltage read by the A/D is then representative of the amount of time elapsed from the time the current source starts and stops charging the circuit.

If the CTMU is being used as a time delay, both capacitance and current source are fixed, as well as the voltage supplied to the comparator circuit. The delay of a signal is determined by the amount of time it takes the voltage to charge to the comparator threshold voltage.

### 25.1.1 THEORY OF OPERATION

The operation of the CTMU is based on the equation for charge:

$$C = I \cdot \frac{dV}{dT}$$

More simply, the amount of charge measured in coulombs in a circuit is defined as current in amperes ( $I$ ) multiplied by the amount of time in seconds that the current flows ( $t$ ). Charge is also defined as the capacitance in farads ( $C$ ) multiplied by the voltage of the circuit ( $V$ ). It follows that:

$$I \cdot t = C \cdot V.$$

The CTMU module provides a constant, known current source. The A/D Converter is used to measure ( $V$ ) in the equation, leaving two unknowns: capacitance ( $C$ ) and time ( $t$ ). The above equation can be used to calculate capacitance or time, by either the relationship using the known fixed capacitance of the circuit:

$$t = (C \cdot V) / I$$

or by:

$$C = (I \cdot t) / V$$

using a fixed time that the current source is applied to the circuit.

### 25.1.2 CURRENT SOURCE

At the heart of the CTMU is a precision current source, designed to provide a constant reference for measurements. The level of current is user-selectable across three ranges or a total of two orders of magnitude, with the ability to trim the output in  $\pm 2\%$  increments (nominal). The current range is selected by the  $IRNG<1:0>$  bits (CTMUICON<1:0>), with a value of '00' representing the lowest range.

Current trim is provided by the  $ITRIM<5:0>$  bits (CTMUICON<7:2>). These six bits allow trimming of the current source in steps of approximately 2% per step. Note that half of the range adjusts the current source positively and the other half reduces the current source. A value of '000000' is the neutral position (no change). A value of '100000' is the maximum negative adjustment (approximately -62%) and '011111' is the maximum positive adjustment (approximately +62%).

### 25.1.3 EDGE SELECTION AND CONTROL

CTMU measurements are controlled by edge events occurring on the module's two input channels. Each channel, referred to as Edge 1 and Edge 2, can be configured to receive input pulses from one of the edge input pins (CTEDG1 and CTEDG2) or CCPx Special Event Triggers. The input channels are level-sensitive, responding to the instantaneous level on the channel rather than a transition between levels. The inputs are selected using the  $EDG1SEL$  and  $EDG2SEL$  bit pairs (CTMUCONL<3:2, 6:5>).

In addition to source, each channel can be configured for event polarity using the  $EDGE2POL$  and  $EDGE1POL$  bits (CTMUCONL<7,4>). The input channels can also be filtered for an edge event sequence (Edge 1 occurring before Edge 2) by setting the  $EDGSEQEN$  bit (CTMUCONH<2>).

### 25.1.4 EDGE STATUS

The CTMUCON register also contains two Status bits,  $EDG2STAT$  and  $EDG1STAT$  (CTMUCONL<1:0>). Their primary function is to show if an edge response has occurred on the corresponding channel. The CTMU automatically sets a particular bit when an edge response is detected on its channel. The level-sensitive nature of the input channels also means that the Status bits become set immediately if the channel's configuration is changed and is the same as the channel's current state.

The module uses the edge Status bits to control the current source output to external analog modules (such as the A/D Converter). Current is only supplied to external modules when only one (but not both) of the Status bits is set, and shuts current off when both bits are either set or cleared. This allows the CTMU to measure current only during the interval between edges. After both Status bits are set, it is necessary to clear them before another measurement is taken. Both bits should be cleared simultaneously, if possible, to avoid re-enabling the CTMU current source.

In addition to being set by the CTMU hardware, the edge Status bits can also be set by software. This is also the user's application to manually enable or disable the current source. Setting either one (but not both) of the bits enables the current source. Setting or clearing both bits at once disables the source.

## 25.1.5 INTERRUPTS

The CTMU sets its interrupt flag (PIR3<2>) whenever the current source is enabled, then disabled. An interrupt is generated only if the corresponding interrupt enable bit (PIE3<2>) is also set. If edge sequencing is not enabled (i.e., Edge 1 must occur before Edge 2), it is necessary to monitor the edge Status bits and determine which edge occurred last and caused the interrupt.

## 25.2 CTMU Module Initialization

The following sequence is a general guideline used to initialize the CTMU module:

1. Select the current source range using the IRNG bits (CTMUICON<1:0>).
2. Adjust the current source trim using the ITRIM bits (CTMUICON<7:2>).
3. Configure the edge input sources for Edge 1 and Edge 2 by setting the EDG1SEL and EDG2SEL bits (CTMUCONL<3:2 and 6:5>).
4. Configure the input polarities for the edge inputs using the EDG1POL and EDG2POL bits (CTMUCONL<4,7>). The default configuration is for negative edge polarity (high-to-low transitions).
5. Enable edge sequencing using the EDGSEQEN bit (CTMUCONH<2>). By default, edge sequencing is disabled.
6. Select the operating mode (Measurement or Time Delay) with the TGEN bit. The default mode is Time/Capacitance Measurement.
7. Configure the module to automatically trigger an A/D conversion when the second edge event has occurred using the CTRIG bit (CTMUCONH<0>). The conversion trigger is disabled by default.
8. Discharge the connected circuit by setting the IDISSEN bit (CTMUCONH<1>); after waiting a sufficient time for the circuit to discharge, clear IDISSEN.
9. Disable the module by clearing the CTMUEN bit (CTMUCONH<7>).
10. Clear the Edge Status bits, EDG2STAT and EDG1STAT (CTMUCONL<1:0>).
11. Enable both edge inputs by setting the EDGEN bit (CTMUCONH<3>).
12. Enable the module by setting the CTMUEN bit.

Depending on the type of measurement or pulse generation being performed, one or more additional modules may also need to be initialized and configured with the CTMU module:

- Edge Source Generation: In addition to the external edge input pins, CCPx Special Event Triggers can be used as edge sources for the CTMU.
- Capacitance or Time Measurement: The CTMU module uses the A/D Converter to measure the voltage across a capacitor that is connected to one of the analog input channels.
- Pulse Generation: When generating system clock independent output pulses, the CTMU module uses Comparator 2 and the associated comparator voltage reference.

## 25.3 Calibrating the CTMU Module

The CTMU requires calibration for precise measurements of capacitance and time, as well as for accurate time delay. If the application only requires measurement of a relative change in capacitance or time, calibration is usually not necessary. An example of this type of application would include a capacitive touch switch, in which the touch circuit has a baseline capacitance, and the added capacitance of the human body changes the overall capacitance of a circuit.

If actual capacitance or time measurement is required, two hardware calibrations must take place: the current source needs calibration to set it to a precise current, and the circuit being measured needs calibration to measure and/or nullify all other capacitance other than that to be measured.

### 25.3.1 CURRENT SOURCE CALIBRATION

The current source onboard the CTMU module has a range of  $\pm 60\%$  nominal for each of three current ranges. Therefore, for precise measurements, it is possible to measure and adjust this current source by placing a high-precision resistor,  $R_{CAL}$ , onto an unused analog channel. An example circuit is shown in [Figure 25-2](#). The current source measurement is performed using the following steps:

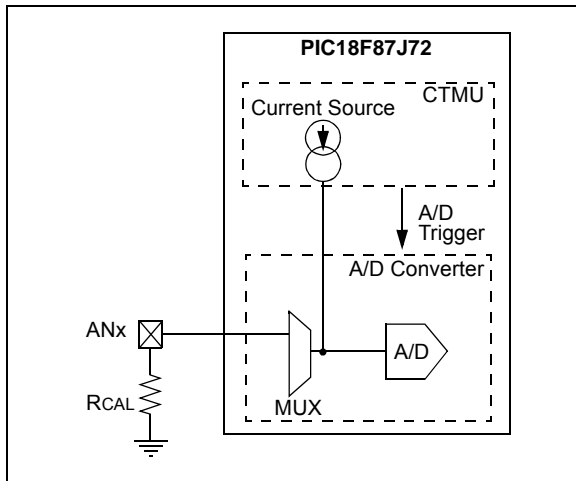
1. Initialize the A/D Converter.
2. Initialize the CTMU.
3. Enable the current source by setting EDG1STAT (CTMUCONL<0>).
4. Issue settling time delay.
5. Perform A/D conversion.
6. Calculate the current source current using  $I = V/R_{CAL}$ , where  $R_{CAL}$  is a high-precision resistance and  $V$  is measured by performing an A/D conversion.

# PIC18F87J72

The CTMU current source may be trimmed with the trim bits in CTMUICON using an iterative process to get an exact desired current. Alternatively, the nominal value without adjustment may be used; it may be stored by the software for use in all subsequent capacitive or time measurements.

To calculate the value for  $R_{CAL}$ , the nominal current must be chosen, and then the resistance can be calculated. For example, if the A/D Converter reference voltage is 3.3V, use 70% of full scale or 2.31V as the desired approximate voltage to be read by the A/D Converter. If the range of the CTMU current source is selected to be 0.55  $\mu\text{A}$ , the resistor value needed is calculated as  $R_{CAL} = 2.31\text{V}/0.55 \mu\text{A}$ , for a value of 4.2 M $\Omega$ . Similarly, if the current source is chosen to be 5.5  $\mu\text{A}$ ,  $R_{CAL}$  would be 420,000 $\Omega$ , and 42,000 $\Omega$  if the current source is set to 55  $\mu\text{A}$ .

**FIGURE 25-2: CTMU CURRENT SOURCE CALIBRATION CIRCUIT**



A value of 70% of full-scale voltage is chosen to make sure that the A/D Converter was in a range that is well above the noise floor. Keep in mind that if an exact current is chosen to incorporate the trimming bits from CTMUICON, the resistor value of  $R_{CAL}$  may need to be adjusted accordingly.  $R_{CAL}$  may be also adjusted to allow for available resistor values.  $R_{CAL}$  should be of the highest precision available, keeping in mind the amount of precision needed for the circuit that the CTMU will be used to measure. A recommended minimum would be 0.1% tolerance.

The following examples show one typical method for performing a CTMU current calibration. [Example 25-1](#) demonstrates how to initialize the A/D Converter and the CTMU. This routine is typical for applications using both modules. [Example 25-2](#) demonstrates one method for the actual calibration routine. Note that this method manually triggers the A/D Converter, which is done to demonstrate the entire stepwise process. It is also possible to automatically trigger the conversion by setting the CTMU's CTRIG bit (CTMUCONH<0>).



## EXAMPLE 25-1: SETUP FOR CTMU CALIBRATION ROUTINES

```

#include "p18cxxx.h"
/*****
/*Setup CTMU *****/
*****/
void setup(void)

{ //CTMUCON - CTMU Control register

    CTMUCONH = 0x00;           //make sure CTMU is disabled
    CTMUCONL = 0X90;
    //CTMU continues to run when emulator is stopped,CTMU continues
    //to run in idle mode,Time Generation mode disabled, Edges are blocked
    //No edge sequence order, Analog current source not grounded, trigger
    //output disabled, Edge2 polarity = positive level, Edge2 source =
    //source 0, Edge1 polarity = positive level, Edge1 source = source 0,
    // Set Edge status bits to zero

    //CTMUICON - CTMU Current Control Register
    CTMUICON = 0x01;           //0.55uA, Nominal - No Adjustment

/*****
//Setup AD converter;
*****/

    TRISA=0x04;                //set channel 2 as an input

    // Configured AN2 as an analog channel
    // ANCON0
    ANCON0 = 0XFB;
    // ANCON1
    ANCON1 = 0X1F;

    // ADCON1
    ADCON1bits.ADFM=1;         // Result format 1= Right justified
    ADCON1bits.ADCAL=0;        // Normal A/D conversion operation
    ADCON1bits.ACQT=1;         // Acquisition time 7 = 20TAD 2 = 4TAD 1=2TAD
    ADCON1bits.ADCS=2;         // Clock conversion bits 6= FOSC/64 2=FOSC/32

    ANCON1bits.VBGEN=1;        // Turn on the Bandgap needed for Rev A0 parts

    // ADCON0
    ADCON0bits.VCFG0 =0;        // Vref+ = AVdd
    ADCON0bits.VCFG1 =0;        // Vref- = AVss
    ADCON0bits.CHS=2;          // Select ADC channel

    ADCON0bits.ADON=1;         // Turn on ADC

}

```

# PIC18F87J72

## EXAMPLE 25-2: CURRENT CALIBRATION ROUTINE

```
#include "p18cxxx.h"

#define COUNT 500 // @ 8MHz = 125uS.
#define DELAY for(i=0;i<COUNT;i++)
#define RCAL .027 // R value is 4200000 (4.2M)
// scaled so that result is in
// 1/100th of uA
#define ADSCALE 1023 // for unsigned conversion 10 sig bits
#define ADREF 3.3 // Vdd connected to A/D Vr+

int main(void)
{
    int i;
    int j = 0; // index for loop
    unsigned int Vread = 0;
    double VTot = 0;
    float Vavg=0, Vcal=0, CTMUISrc = 0; // float values stored for calcs

    // assume CTMU and A/D have been setup correctly
    // see Example 25-1 for CTMU & A/D setup
    setup();

    CTMUCONHbits.CTMUEN = 1; // Enable the CTMU
    for(j=0;j<10;j++)
    {
        CTMUCONHbits.IDISSEN = 1; // drain charge on the circuit
        DELAY; // wait 125us
        CTMUCONHbits.IDISSEN = 0; // end drain of circuit

        CTMUCONLbits.EDG1STAT = 1; // Begin charging the circuit
        // using CTMU current source
        DELAY; // wait for 125us
        CTMUCONLbits.EDG1STAT = 0; // Stop charging circuit

        PIR1bits.ADIF = 0; // make sure A/D Int not set
        ADCON0bits.GO=1; // and begin A/D conv.
        while(!PIR1bits.ADIF); // Wait for A/D convert complete

        Vread = ADRES; // Get the value from the A/D
        PIR1bits.ADIF = 0; // Clear A/D Interrupt Flag
        VTot += Vread; // Add the reading to the total
    }

    Vavg = (float)(VTot/10.000); // Average of 10 readings
    Vcal = (float)(Vavg/ADSCALE*ADREF);
    CTMUISrc = Vcal/RCAL; // CTMUISrc is in 1/100ths of uA
}
```

## 25.3.2 CAPACITANCE CALIBRATION

There is a small amount of capacitance from the internal A/D Converter sample capacitor as well as stray capacitance from the circuit board traces and pads that affect the precision of capacitance measurements. A measurement of the stray capacitance can be taken by making sure the desired capacitance to be measured has been removed. The measurement is then performed using the following steps:

1. Initialize the A/D Converter and the CTMU.
2. Set EDG1STAT (= 1).
3. Wait for a fixed delay of time,  $t$ .
4. Clear EDG1STAT.
5. Perform an A/D conversion.
6. Calculate the stray and A/D sample capacitances:

$$C_{\text{OFFSET}} = C_{\text{STRAY}} + C_{\text{AD}} = (I \cdot t) / V$$

where  $I$  is known from the current source measurement step,  $t$  is a fixed delay and  $V$  is measured by performing an A/D conversion.

This measured value is then stored and used for calculations of time measurement, or subtracted for capacitance measurement. For calibration, it is expected that the capacitance of  $C_{\text{STRAY}} + C_{\text{AD}}$  is approximately known.  $C_{\text{AD}}$  is approximately 4 pF.

An iterative process may need to be used to adjust the time,  $t$ , that the circuit is charged to obtain a reasonable voltage reading from the A/D Converter. The value of  $t$  may be determined by setting  $C_{\text{OFFSET}}$  to a theoretical value, then solving for  $t$ . For example, if  $C_{\text{STRAY}}$  is theoretically calculated to be 11 pF, and  $V$  is expected to be 70% of  $V_{\text{DD}}$ , or 2.31V, then  $t$  would be:

$$(4 \text{ pF} + 11 \text{ pF}) \cdot 2.31 \text{ V} / 0.55 \text{ } \mu\text{A}$$

or 63  $\mu\text{s}$ .

See [Example 25-3](#) for a typical routine for CTMU capacitance calibration.

# PIC18F87J72

## EXAMPLE 25-3: CAPACITANCE CALIBRATION ROUTINE

```
#include "p18cxxx.h"

#define COUNT 25 // @ 8MHz INTFRC = 62.5 us.
#define ETIME COUNT*2.5 // time in uS
#define DELAY for(i=0;i<COUNT;i++)
#define ADSCALE 1023 // for unsigned conversion 10 sig bits
#define ADREF 3.3 // Vdd connected to A/D Vr+
#define RCAL .027 // R value is 4200000 (4.2M)
// scaled so that result is in
// 1/100th of uA

int main(void)
{
    int i;
    int j = 0; // index for loop
    unsigned int Vread = 0;
    float CTMUISrc, CTMUCap, Vavg, VTot, Vcal;

    // assume CTMU and A/D have been setup correctly
    // see Example 25-1 for CTMU & A/D setup
    setup();

    CTMUCONHbits.CTMUEN = 1; // Enable the CTMU
    for(j=0;j<10;j++)
    {
        CTMUCONHbits.IDISSEN = 1; // drain charge on the circuit
        DELAY; // wait 125us
        CTMUCONHbits.IDISSEN = 0; // end drain of circuit

        CTMUCONLbits.EDG1STAT = 1; // Begin charging the circuit
        // using CTMU current source
        DELAY; // wait for 125us
        CTMUCONLbits.EDG1STAT = 0; // Stop charging circuit

        PIR1bits.ADIF = 0; // make sure A/D Int not set
        ADCON0bits.GO=1; // and begin A/D conv.
        while(!PIR1bits.ADIF); // Wait for A/D convert complete

        Vread = ADRES; // Get the value from the A/D
        PIR1bits.ADIF = 0; // Clear A/D Interrupt Flag
        VTot += Vread; // Add the reading to the total
    }

    Vavg = (float)(VTot/10.000); // Average of 10 readings
    Vcal = (float)(Vavg/ADSCALE*ADREF);
    CTMUISrc = Vcal/RCAL; // CTMUISrc is in 1/100ths of uA
    CTMUCap = (CTMUISrc*ETIME/Vcal)/100;
}
```

## 25.4 Measuring Capacitance with the CTMU

There are two separate methods of measuring capacitance with the CTMU. The first is the absolute method, in which the actual capacitance value is desired. The second is the relative method, in which the actual capacitance is not needed, rather an indication of a change in capacitance is required.

### 25.4.1 ABSOLUTE CAPACITANCE MEASUREMENT

For absolute capacitance measurements, both the current and capacitance calibration steps found in [Section 25.3 “Calibrating the CTMU Module”](#) should be followed. Capacitance measurements are then performed using the following steps:

1. Initialize the A/D Converter.
2. Initialize the CTMU.
3. Set EDG1STAT.
4. Wait for a fixed delay,  $T$ .
5. Clear EDG1STAT.
6. Perform an A/D conversion.
7. Calculate the total capacitance,  $C_{TOTAL} = (I * T) / V$ , where  $I$  is known from the current source measurement step ([Section 25.3.1 “Current Source Calibration”](#)),  $T$  is a fixed delay and  $V$  is measured by performing an A/D conversion.
8. Subtract the stray and A/D capacitance ( $C_{OFFSET}$  from [Section 25.3.2 “Capacitance Calibration”](#)) from  $C_{TOTAL}$  to determine the measured capacitance.

### 25.4.2 RELATIVE CHARGE MEASUREMENT

An application may not require precise capacitance measurements. For example, when detecting a valid press of a capacitance-based switch, detecting a relative change of capacitance is of interest. In this type of application, when the switch is open (or not touched), the total capacitance is the capacitance of the combination of the board traces, the A/D Converter, etc. A larger voltage will be measured by the A/D Converter. When the switch is closed (or is touched), the total capacitance is larger due to the addition of the capacitance of the human body to the above listed capacitances and a smaller voltage will be measured by the A/D Converter.

Detecting capacitance changes is easily accomplished with the CTMU using these steps:

1. Initialize the A/D Converter and the CTMU.
2. Set EDG1STAT.
3. Wait for a fixed delay.
4. Clear EDG1STAT.
5. Perform an A/D conversion.

The voltage measured by performing the A/D conversion is an indication of the relative capacitance. Note that in this case, no calibration of the current source or circuit capacitance measurement is needed. See [Example 25-4](#) for a sample software routine for a capacitive touch switch.

# PIC18F87J72

## EXAMPLE 25-4: ROUTINE FOR CAPACITIVE TOUCH SWITCH

```
#include "p18cxxx.h"

#define COUNT 500                //@ 8MHz = 125uS.
#define DELAY for(i=0;i<COUNT;i++)
#define OPENSW 1000              //Un-pressed switch value
#define TRIP 300                 //Difference between pressed
                                //and un-pressed switch
#define HYST 65                  //amount to change
                                //from pressed to un-pressed

#define PRESSED 1
#define UNPRESSED 0

int main(void)
{
    unsigned int Vread;           //storage for reading
    unsigned int switchState;
    int i;

    //assume CTMU and A/D have been setup correctly
    //see Example 25-1 for CTMU & A/D setup
    setup();

    CTMUCONHbits.CTMUEN = 1;      //Enable the CTMU

    CTMUCONHbits.IDISSEN = 1;     //drain charge on the circuit
    DELAY;                         //wait 125us
    CTMUCONHbits.IDISSEN = 0;     //end drain of circuit

    CTMUCONLbits.EDG1STAT = 1;    //Begin charging the circuit
    //using CTMU current source
    DELAY;                         //wait for 125us
    CTMUCONLbits.EDG1STAT = 0;    //Stop charging circuit

    PIR1bits.ADIF = 0;            //make sure A/D Int not set
    ADCON0bits.GO=1;              //and begin A/D conv.
    while(!PIR1bits.ADIF);        //Wait for A/D convert complete

    Vread = ADRES;                //Get the value from the A/D

    if(Vread < OPENSW - TRIP)
    {
        switchState = PRESSED;
    }
    else if(Vread > OPENSW - TRIP + HYST)
    {
        switchState = UNPRESSED;
    }
}
```

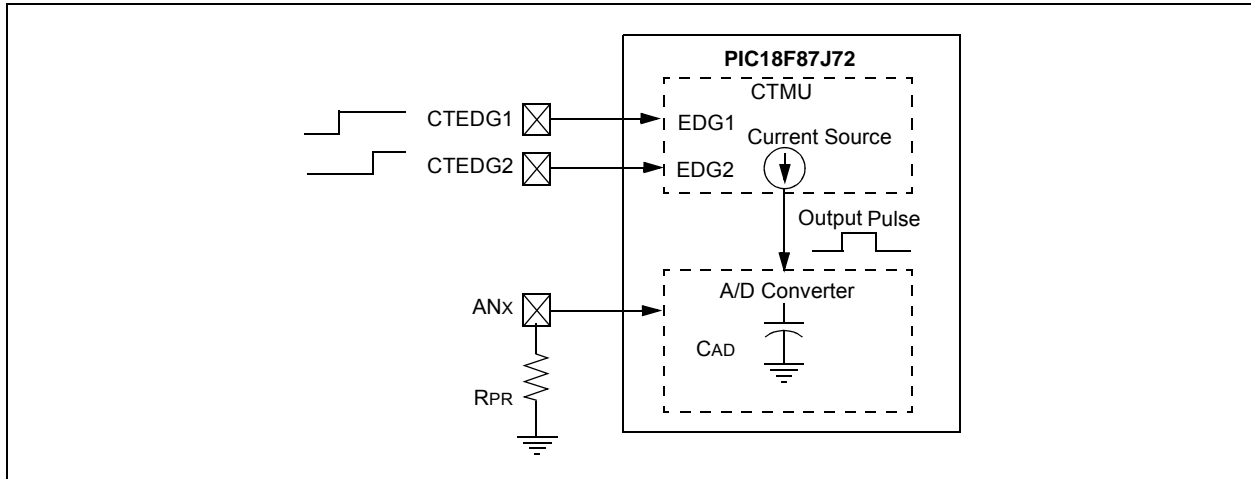
## 25.5 Measuring Time with the CTMU Module

Time can be precisely measured after the ratio ( $C/I$ ) is measured from the current and capacitance calibration step by following these steps:

1. Initialize the A/D Converter and the CTMU.
2. Set EDG1STAT.
3. Set EDG2STAT.
4. Perform an A/D conversion.
5. Calculate the time between edges as  $T = (C/I) * V$ , where  $I$  is calculated in the current calibration step (Section 25.3.1 "Current Source Calibration"),  $C$  is calculated in the capacitance calibration step (Section 25.3.2 "Capacitance Calibration") and  $V$  is measured by performing the A/D conversion.

It is assumed that the time measured is small enough that the capacitance  $C_{OFFSET}$  provides a valid voltage to the A/D Converter. For the smallest time measurement, always set the A/D Channel Select register (AD1CHS) to an unused A/D channel; the corresponding pin for which is not connected to any circuit board trace. This minimizes added stray capacitance, keeping the total circuit capacitance close to that of the A/D Converter itself (25 pF). To measure longer time intervals, an external capacitor may be connected to an A/D channel, and this channel selected when making a time measurement.

**FIGURE 25-3: TYPICAL CONNECTIONS AND INTERNAL CONFIGURATION FOR TIME MEASUREMENT**



# PIC18F87J72

## 25.6 Creating a Delay with the CTMU Module

A unique feature on board the CTMU module is its ability to generate system clock independent output pulses based on an external capacitor value. This is accomplished using the internal comparator voltage reference module, Comparator 2 input pin and an external capacitor. The pulse is output onto the CTPLS pin. To enable this mode, set the TGEN bit.

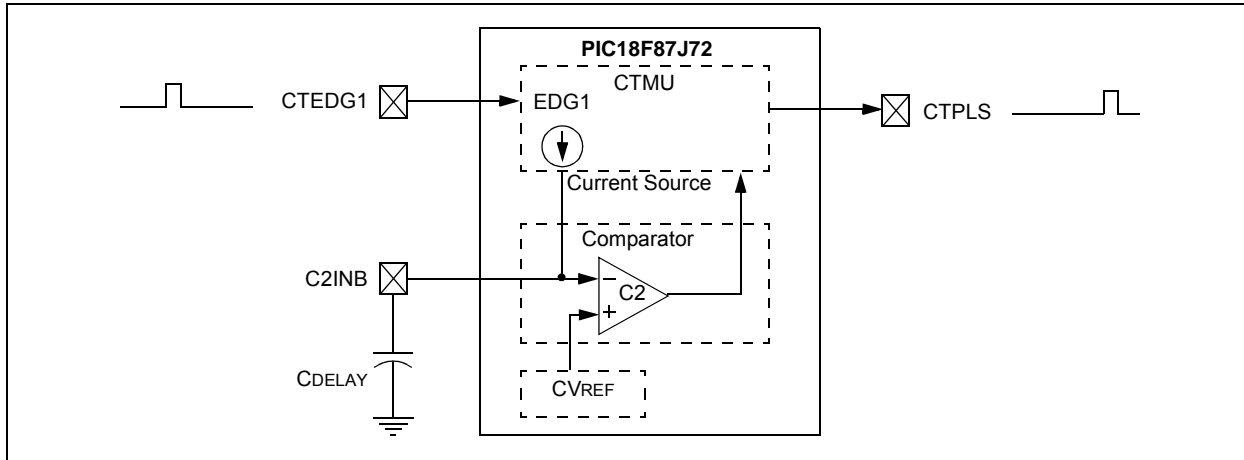
See [Figure 25-4](#) for an example circuit.  $C_{PULSE}$  is chosen by the user to determine the output pulse width on CTPLS. The pulse width is calculated by  $T = (C_{PULSE}/I) * V$ , where  $I$  is known from the current source measurement step ([Section 25.3.1 “Current Source Calibration”](#)) and  $V$  is the internal reference voltage ( $V_{REF}$ ).

An example use of this feature is for interfacing with variable capacitive-based sensors, such as a humidity sensor. As the humidity varies, the pulse-width output on CTPLS will vary. The CTPLS output pin can be connected to an input capture pin and the varying pulse width is measured to determine the humidity in the application.

Follow these steps to use this feature:

1. Initialize Comparator 2.
2. Initialize the comparator voltage reference.
3. Initialize the CTMU and enable time delay generation by setting the TGEN bit.
4. Set EDG1STAT.
5. When  $C_{PULSE}$  charges to the value of the voltage reference trip point, an output pulse is generated on CTPLS.

**FIGURE 25-4: TYPICAL CONNECTIONS AND INTERNAL CONFIGURATION FOR PULSE DELAY GENERATION**



## 25.7 Operation During Sleep/Idle Modes

### 25.7.1 SLEEP MODE AND DEEP SLEEP MODES

When the device enters any Sleep mode, the CTMU module current source is always disabled. If the CTMU is performing an operation that depends on the current source when Sleep mode is invoked, the operation may not terminate correctly. Capacitance and time measurements may return erroneous values.

### 25.7.2 IDLE MODE

The behavior of the CTMU in Idle mode is determined by the CTMUSIDL bit (CTMUCONH<5>). If CTMUSIDL is cleared, the module will continue to operate in Idle mode. If CTMUSIDL is set, the module's current source is disabled when the device enters Idle mode. If the module is performing an operation when Idle mode is invoked, in this case, the results will be similar to those with Sleep mode.

## 25.8 Effects of a Reset on CTMU

Upon Reset, all registers of the CTMU are cleared. This leaves the CTMU module disabled, its current source is turned off and all configuration options return to their default settings. The module needs to be re-initialized following any Reset.

If the CTMU is in the process of taking a measurement at the time of Reset, the measurement will be lost. A partial charge may exist on the circuit that was being measured, and should be properly discharged before the CTMU makes subsequent attempts to make a measurement. The circuit is discharged by setting and then clearing the IDISSEN bit (CTMUCONH<1>) while the A/D Converter is connected to the appropriate channel.



## 25.9 Registers

There are three control registers for the CTMU:

- CTMUCONH
- CTMUCONL
- CTMUICON

The CTMUCONH and CTMUCONL registers ([Register 25-1](#) and [Register 25-2](#)) contain control bits for configuring the CTMU module edge source selection, edge source polarity selection, edge sequencing, A/D trigger, analog circuit capacitor discharge and enables. The CTMUICON register ([Register 25-3](#)) has bits for selecting the current source range and current source trim.

### REGISTER 25-1: CTMUCONH: CTMU CONTROL HIGH REGISTER

R/W-0	U-0	R/W-0	R/W-0	R/W-0	R/W-0	R/W-0	R/W-0
CTMUEN	—	CTMUSIDL	TGEN	EDGEN	EDGSEQEN	IDISSEN	CTTRIG
bit 7							bit 0

Legend:

R = Readable bit

W = Writable bit

U = Unimplemented bit, read as '0'

-n = Value at POR

'1' = Bit is set

'0' = Bit is cleared

x = Bit is unknown

- bit 7      **CTMUEN:** CTMU Enable bit  
           1 = Module is enabled  
           0 = Module is disabled
- bit 6      **Unimplemented:** Read as '0'
- bit 5      **CTMUSIDL:** Stop in Idle Mode bit  
           1 = Discontinue module operation when device enters Idle mode  
           0 = Continue module operation in Idle mode
- bit 4      **TGEN:** Time Generation Enable bit  
           1 = Enables edge delay generation  
           0 = Disables edge delay generation
- bit 3      **EDGEN:** Edge Enable bit  
           1 = Edges are not blocked  
           0 = Edges are blocked
- bit 2      **EDGSEQEN:** Edge Sequence Enable bit  
           1 = Edge 1 event must occur before Edge 2 event can occur  
           0 = No edge sequence is needed
- bit 1      **IDISSEN:** Analog Current Source Control bit  
           1 = Analog current source output is grounded  
           0 = Analog current source output is not grounded
- bit 0      **CTTRIG:** Trigger Control bit  
           1 = Trigger output is enabled  
           0 = Trigger output is disabled

# PIC18F87J72

## REGISTER 25-2: CTMUCONL: CTMU CONTROL LOW REGISTER

R/W-0	R/W-0	R/W-0	R/W-0	R/W-0	R/W-0	R/W-0	R/W-0
EDG2POL	EDG2SEL1	EDG2SEL0	EDG1POL	EDG1SEL1	EDG1SEL0	EDG2STAT	EDG1STAT
bit 7							bit 0

### Legend:

R = Readable bit

W = Writable bit

U = Unimplemented bit, read as '0'

-n = Value at POR

'1' = Bit is set

'0' = Bit is cleared

x = Bit is unknown

- bit 7      **EDG2POL:** Edge 2 Polarity Select bit  
1 = Edge 2 is programmed for a positive edge response  
0 = Edge 2 is programmed for a negative edge response
- bit 6-5    **EDG2SEL<1:0>:** Edge 2 Source Select bits  
11 = CTEDG1 pin  
10 = CTEDG2 pin  
01 = CCP1 Special Event Trigger  
00 = CCP2 Special Event Trigger
- bit 4      **EDG1POL:** Edge 1 Polarity Select bit  
1 = Edge 1 is programmed for a positive edge response  
0 = Edge 1 is programmed for a negative edge response
- bit 3-2    **EDG1SEL<1:0>:** Edge 1 Source Select bits  
11 = CTEDG1 pin  
10 = CTEDG2 pin  
01 = CCP1 Special Event Trigger  
00 = CCP2 Special Event Trigger
- bit 1      **EDG2STAT:** Edge 2 Status bit  
1 = Edge 2 event has occurred  
0 = Edge 2 event has not occurred
- bit 0      **EDG1STAT:** Edge 1 Status bit  
1 = Edge 1 event has occurred  
0 = Edge 1 event has not occurred

## REGISTER 25-3: CTMUICON: CTMU CURRENT CONTROL REGISTER

R/W-0	R/W-0	R/W-0	R/W-0	R/W-0	R/W-0	R/W-0	R/W-0
ITRIM5	ITRIM4	ITRIM3	ITRIM2	ITRIM1	ITRIM0	IRNG1	IRNG0
bit 7							bit 0

### Legend:

R = Readable bit                      W = Writable bit                      U = Unimplemented bit, read as '0'  
 -n = Value at POR                      '1' = Bit is set                      '0' = Bit is cleared                      x = Bit is unknown

bit 7-2        **ITRIM<5:0>**: Current Source Trim bits  
 011111 = Maximum positive change from nominal current  
 011110  
 .  
 .  
 .  
 000001 = Minimum positive change from nominal current  
 000000 = Nominal current output specified by IRNG<1:0>  
 111111 = Minimum negative change from nominal current  
 .  
 .  
 .  
 100010  
 100001 = Maximum negative change from nominal current

bit 1-0        **IRNG<1:0>**: Current Source Range Select bits  
 11 = 100 x Base current  
 10 = 10 x Base current  
 01 = Base current level (0.55  $\mu$ A nominal)  
 00 = Current source disabled

**TABLE 25-1: REGISTERS ASSOCIATED WITH CTMU MODULE**

Name	Bit 7	Bit 6	Bit 5	Bit 4	Bit 3	Bit 2	Bit 1	Bit 0	Reset Values on page
CTMUCONH	CTMUEN	—	CTMUSIDL	TGEN	EDGEN	EDGSEQEN	IDISSEN	CTTRIG	50
CTMUCONL	EDG2POL	EDG2SEL1	EDG2SEL0	EDG1POL	EDG1SEL1	EDG1SEL0	EDG2STAT	EDG1STAT	50
CTMUICON	ITRIM5	ITRIM4	ITRIM3	ITRIM2	ITRIM1	ITRIM0	IRNG1	IRNG0	50

Legend: — = unimplemented, read as '0'. Shaded cells are not used during CCP operation.

## 26.0 SPECIAL FEATURES OF THE CPU

PIC18F87J72 family devices include several features intended to maximize reliability and minimize cost through elimination of external components. These are:

- Oscillator Selection
- Resets:
  - Power-on Reset (POR)
  - Power-up Timer (PWRT)
  - Oscillator Start-up Timer (OST)
  - Brown-out Reset (BOR)
- Interrupts
- Watchdog Timer (WDT)
- Fail-Safe Clock Monitor
- Two-Speed Start-up
- Code Protection
- In-Circuit Serial Programming

The oscillator can be configured for the application depending on frequency, power, accuracy and cost. All of the options are discussed in detail in [Section 3.0 “Oscillator Configurations”](#).

A complete discussion of device Resets and interrupts is available in previous sections of this data sheet.

In addition to their Power-up and Oscillator Start-up Timers provided for Resets, the PIC18F87J72 family of devices has a configurable Watchdog Timer which is controlled in software.

The inclusion of an internal RC oscillator also provides the additional benefits of a Fail-Safe Clock Monitor (FSCM) and Two-Speed Start-up. FSCM provides for background monitoring of the peripheral clock and automatic switchover in the event of its failure. Two-Speed Start-up enables code to be executed almost immediately on start-up, while the primary clock source completes its start-up delays.

All of these features are enabled and configured by setting the appropriate Configuration register bits.

### 26.1 Configuration Bits

The Configuration bits can be programmed (read as ‘0’), or left unprogrammed (read as ‘1’), to select various device configurations. These bits are mapped starting at program memory location, 300000h. A complete list is shown in [Table 26-1](#). A detailed explanation of the various bit functions is provided in [Register 26-1](#) through [Register 26-6](#).

### 26.1.1 CONSIDERATIONS FOR CONFIGURING PIC18F87J72 FAMILY DEVICES

Devices of the PIC18F87J72 family do not use persistent memory registers to store configuration information. The configuration bytes are implemented as volatile memory which means that configuration data must be programmed each time the device is powered up.

Configuration data is stored in the three words at the top of the on-chip program memory space, known as the Flash Configuration Words. It is stored in program memory in the same order shown in [Table 26-1](#), with CONFIG1L at the lowest address and CONFIG3H at the highest. The data is automatically loaded in the proper Configuration registers during device power-up.

When creating applications for these devices, users should always specifically allocate the location of the Flash Configuration Word for configuration data. This is to make certain that program code is not stored in this address when the code is compiled.

The volatile memory cells used for the Configuration bits always reset to ‘1’ on Power-on Resets. For all other types of Reset events, the previously programmed values are maintained and used without reloading from program memory.

The four Most Significant bits of CONFIG1H, CONFIG2H and CONFIG3H in program memory should also be ‘1111’. This makes these Configuration Words appear to be NOP instructions in the remote event that their locations are ever executed by accident. Since Configuration bits are not implemented in the corresponding locations, writing ‘1’s to these locations has no effect on device operation.

To prevent inadvertent configuration changes during code execution, all programmable Configuration bits are write-once. After a bit is initially programmed during a power cycle, it cannot be written to again. Changing a device configuration requires that power to the device be cycled.

**TABLE 26-1: MAPPING OF THE FLASH CONFIGURATION WORDS TO THE CONFIGURATION REGISTERS**

Configuration Byte	Code Space Address	Configuration Register Address
CONFIG1L	XXXF8h	300000h
CONFIG1H	XXXF9h	300001h
CONFIG2L	XXXFAh	300002h
CONFIG2H	XXXFBh	300003h
CONFIG3L	XXXFCh	300004h
CONFIG3H	XXXFDh	300005h

**TABLE 26-2: CONFIGURATION BITS AND DEVICE IDs**

File Name		Bit 7	Bit 6	Bit 5	Bit 4	Bit 3	Bit 2	Bit 1	Bit 0	Default/ Unprogrammed Value <sup>(1)</sup>
300000h	CON- FIG1L	DEBUG	XINST	STVREN	—	—	—	—	WDTEN	111- ---1
300001h	CON- FIG1H	— <sup>(2)</sup>	— <sup>(2)</sup>	— <sup>(2)</sup>	— <sup>(2)</sup>	— <sup>(3)</sup>	CP0	—	—	---- 01--
300002h	CON- FIG2L	IESO	FCMEN	—	LPT1OS C	T1DIG	FOSC2	FOSC1	FOSC0	11-1 1111
300003h	CON- FIG2H	— <sup>(2)</sup>	— <sup>(2)</sup>	— <sup>(2)</sup>	— <sup>(2)</sup>	WDTPS3	WDTPS2	WDTPS1	WDTPS0	---- 1111
300004h	CON- FIG3L	— <sup>(2)</sup>	— <sup>(2)</sup>	— <sup>(2)</sup>	— <sup>(2)</sup>	—	—	RTCOSC	—	---- --1-
300005h	CON- FIG3H	— <sup>(2)</sup>	— <sup>(2)</sup>	— <sup>(2)</sup>	— <sup>(2)</sup>	—	—	—	CCP2MX	---- ---1
3FFFFE h	DEVID1	DEV2	DEV1	DEV0	REV4	REV3	REV2	REV1	REV0	01xx xxxx <sup>(4)</sup>
3FFFFFh	DEVID2	DEV10	DEV9	DEV8	DEV7	DEV6	DEV5	DEV4	DEV3	0101 0000 <sup>(4)</sup>

Legend: x = unknown, - = unimplemented. Shaded cells are unimplemented, read as '0'.

- Note**
- 1: Values reflect the unprogrammed state as received from the factory and following Power-on Resets. In all other Reset states, the configuration bytes maintain their previously programmed states.
  - 2: The value of these bits in program memory should always be '1'. This ensures that the location is executed as a NOP if it is accidentally executed.
  - 3: This bit should always be maintained as '0'.
  - 4: These registers are read-only and cannot be programmed by the user. See [Register 26-7](#) for device-specific values for DEVID1.

# PIC18F87J72

**REGISTER 26-1: CONFIG1L: CONFIGURATION REGISTER 1 LOW (BYTE ADDRESS 300000h)**

R/WO-1	R/WO-1	R/WO-1	U-0	U-0	U-0	U-0	R/WO-1
$\overline{\text{DEBUG}}$	XINST	STVREN	—	—	—	—	WDTEN
bit 7							bit 0

Legend:

R = Readable bit                      WO = Write-Once bit                      U = Unimplemented bit, read as '0'  
 -n = Value when device is unprogrammed                      '1' = Bit is set                      '0' = Bit is cleared

- bit 7            **DEBUG:** Background Debugger Enable bit  
                   1 = Background debugger is disabled; RB6 and RB7 are configured as general purpose I/O pins  
                   0 = Background debugger is enabled; RB6 and RB7 are dedicated to In-Circuit Debug
- bit 6            **XINST:** Extended Instruction Set Enable bit  
                   1 = Instruction set extension and Indexed Addressing mode are enabled  
                   0 = Instruction set extension and Indexed Addressing mode are disabled (Legacy mode)
- bit 5            **STVREN:** Stack Overflow/Underflow Reset Enable bit  
                   1 = Reset on stack overflow/underflow is enabled  
                   0 = Reset on stack overflow/underflow is disabled
- bit 4-1        **Unimplemented:** Read as '0'
- bit 0            **WDTEN:** Watchdog Timer Enable bit  
                   1 = WDT is enabled  
                   0 = WDT is disabled (control is placed on SWDTEN bit)

**REGISTER 26-2: CONFIG1H: CONFIGURATION REGISTER 1 HIGH (BYTE ADDRESS 300001h)**

U-0	U-0	U-0	U-0	U-0	R/WO-1	U-0	U-0
—(1)	—(1)	—(1)	—(1)	—(2)	CP0	—	—
bit 7							bit 0

Legend:

R = Readable bit                      WO = Write-Once bit                      U = Unimplemented bit, read as '0'  
 -n = Value when device is unprogrammed                      '1' = Bit is set                      '0' = Bit is cleared

- bit 7-3        **Unimplemented:** Read as '0'
- bit 2            **CP0:** Code Protection bit  
                   1 = Program memory is not code-protected  
                   0 = Program memory is code-protected
- bit 1-0        **Unimplemented:** Read as '0'

- Note 1:** The value of these bits in program memory should always be '1'. This ensures that the location is executed as a NOP if it is accidentally executed.
- 2:** This bit should always be maintained as '0'.

## REGISTER 26-3: CONFIG2L: CONFIGURATION REGISTER 2 LOW (BYTE ADDRESS 300002h)

R/WO-1	R/WO-1	U-0	R/WO-1	R/WO-1	R/WO-1	R/WO-1	R/WO-1
IESO	FCMEN	—	LPT1OSC	T1DIG	FOSC2	FOSC1	FOSC0
bit 7							bit 0

### Legend:

R = Readable bit                      WO = Write-Once bit                      U = Unimplemented bit, read as '0'  
 -n = Value when device is unprogrammed                      '1' = Bit is set                      '0' = Bit is cleared

- bit 7            **IESO:** Two-Speed Start-up (Internal/External Oscillator Switchover) Control bit  
                   1 = Two-Speed Start-up is enabled  
                   0 = Two-Speed Start-up is disabled
- bit 6            **FCMEN:** Fail-Safe Clock Monitor Enable bit  
                   1 = Fail-Safe Clock Monitor is enabled  
                   0 = Fail-Safe Clock Monitor is disabled
- bit 5            **Unimplemented:** Read as '0'
- bit 4            **LPT1OSC:** T1OSC/SOSC Power Selection Configuration bit  
                   1 = High-power T1OSC/SOSC circuit is selected  
                   0 = Low-power T1OSC/SOSC circuit is selected
- bit 3            **T1DIG:** T1CKI for Digital Input Clock Enable bit  
                   1 = T1CKI is available as a digital input without enabling T1OSCEN  
                   0 = T1CKI is not available as a digital input without enabling T1OSCEN
- bit 2-0        **FOSC<2:0>:** Oscillator Selection bits  
                   111 =ECPLL OSC1/OSC2 as primary; ECPLL oscillator with PLL is enabled; CLKO on RA6  
                   110 =EC OSC1/OSC2 as primary; external clock with Fosc/4 output  
                   101 =HSPLL OSC1/OSC2 as primary; high-speed crystal/resonator with software PLL control  
                   100 =HS OSC1/OSC2 as primary; high-speed crystal/resonator  
                   011 =INTPLL1 internal oscillator block with software PLL control; Fosc/4 output  
                   010 =INTIO1 internal oscillator block with Fosc/4 output on RA6 and I/O on RA7  
                   001 =INTPLL2 internal oscillator block with software PLL control and I/O on RA6 and RA7  
                   000 =INTIO2 internal oscillator block with I/O on RA6 and RA7

# PIC18F87J72

**REGISTER 26-4: CONFIG2H: CONFIGURATION REGISTER 2 HIGH (BYTE ADDRESS 300003h)**

U-0	U-0	U-0	U-0	R/WO-1	R/WO-1	R/WO-1	R/WO-1
—(1)	—(1)	—(1)	—(1)	WDTPS3	WDTPS2	WDTPS1	WDTPS0
bit 7							bit 0

Legend:

R = Readable bit                      WO = Write-Once bit                      U = Unimplemented bit, read as '0'  
 -n = Value when device is unprogrammed                      '1' = Bit is set                      '0' = Bit is cleared

- bit 7-4            **Unimplemented:** Read as '0'
- bit 3-0            **WDTPS<3:0>:** Watchdog Timer Postscale Select bits
  - 1111 = 1:32,768
  - 1110 = 1:16,384
  - 1101 = 1:8,192
  - 1100 = 1:4,096
  - 1011 = 1:2,048
  - 1010 = 1:1,024
  - 1001 = 1:512
  - 1000 = 1:256
  - 0111 = 1:128
  - 0110 = 1:64
  - 0101 = 1:32
  - 0100 = 1:16
  - 0011 = 1:8
  - 0010 = 1:4
  - 0001 = 1:2
  - 0000 = 1:1

**Note 1:** The value of these bits in program memory should always be '1'. This ensures that the location is executed as a NOP if it is accidentally executed.

**REGISTER 26-5: CONFIG3L: CONFIGURATION REGISTER 3 LOW (BYTE ADDRESS 300004h)**

U-0	U-0	U-0	U-0	U-0	U-0	R/WO-1	U-0
—(1)	—(1)	—(1)	—(1)	—	—	RTCOSC	—
bit 7						bit 0	

Legend:

R = Readable bit                      WO = Write-Once bit                      U = Unimplemented bit, read as '0'  
 -n = Value when device is unprogrammed                      '1' = Bit is set                      '0' = Bit is cleared

- bit 7-2            **Unimplemented:** Read as '0'
- bit 1              **RTCOSC:** RTCC Reference Clock Select bit
  - 1 = RTCC uses T1OSC/T1CKI as the reference clock
  - 0 = RTCC uses INTRC as the reference clock
- bit 0              **Unimplemented:** Read as '0'

**Note 1:** The value of these bits in program memory should always be '1'. This ensures that the location is executed as a NOP if it is accidentally executed.



## REGISTER 26-6: CONFIG3H: CONFIGURATION REGISTER 3 HIGH (BYTE ADDRESS 300005h)

U-0	U-0	U-0	U-0	U-0	U-0	U-0	R/WO-1
— <sup>(1)</sup>	— <sup>(1)</sup>	— <sup>(1)</sup>	— <sup>(1)</sup>	—	—	—	CCP2MX
bit 7							bit 0

**Legend:**

R = Readable bit                      WO = Write-Once bit                      U = Unimplemented bit, read as '0'  
 -n = Value when device is unprogrammed                      '1' = Bit is set                      '0' = Bit is cleared

bit 7-1                      **Unimplemented:** Read as '0'  
 bit 0                      **CCP2MX:** CCP2 MUX bit  
                                  1 = CCP2 is multiplexed with RC1  
                                  0 = CCP2 is multiplexed with RE7

**Note 1:** The value of these bits in program memory should always be '1'. This ensures that the location is executed as a NOP if it is accidentally executed.

## REGISTER 26-7: DEVID1: DEVICE ID REGISTER 1

R	R	R	R	R	R	R	R
DEV2	DEV1	DEV0	REV4	REV3	REV2	REV1	REV0
bit 7							bit 0

**Legend:**

R = Read-only bit

bit 7-5                      **DEV<2:0>:** Device ID bits  
                                  011 = PIC18F87J72  
                                  010 = PIC18F86J72  
 bit 4-0                      **REV<4:0>:** Revision ID bits  
                                  These bits are used to indicate the device revision.

## REGISTER 26-8: DEVID2: DEVICE ID REGISTER 2

R	R	R	R	R	R	R	R
DEV10 <sup>(1)</sup>	DEV9 <sup>(1)</sup>	DEV8 <sup>(1)</sup>	DEV7 <sup>(1)</sup>	DEV6 <sup>(1)</sup>	DEV5 <sup>(1)</sup>	DEV4 <sup>(1)</sup>	DEV3 <sup>(1)</sup>
bit 7							bit 0

**Legend:**

R = Read-only bit

bit 7-0                      **DEV<10:3>:** Device ID bits<sup>(1)</sup>  
                                  These bits are used with the DEV<2:0> bits in the Device ID Register 1 to identify the part number.  
                                  0101 0000 = PIC18F87J72 family devices

**Note 1:** The values for DEV<10:3> may be shared with other device families. The specific device is always identified by using the entire DEV<10:0> bit sequence.

# PIC18F87J72

## 26.2 Watchdog Timer (WDT)

For PIC18F87J72 family devices, the WDT is driven by the INTRC oscillator. When the WDT is enabled, the clock source is also enabled. The nominal WDT period is 4 ms and has the same stability as the INTRC oscillator.

The 4 ms period of the WDT is multiplied by a 16-bit postscaler. Any output of the WDT postscaler is selected by a multiplexer, controlled by the WDTPS bits in Configuration Register 2H. Available periods range from 4 ms to 131.072 seconds (2.18 minutes). The WDT and postscaler are cleared whenever a `SLEEP` or `CLRWDT` instruction is executed, or a clock failure (primary or Timer1 oscillator) has occurred.

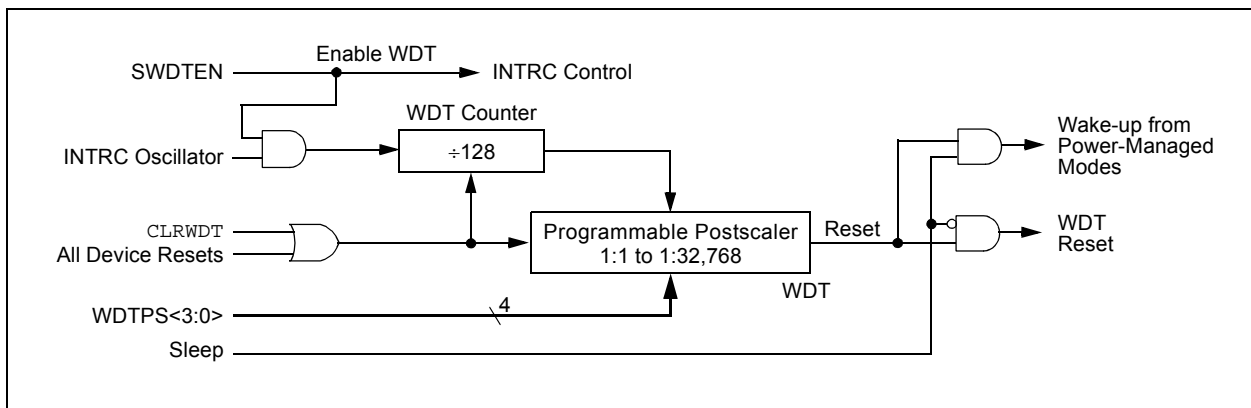
**Note 1:** The `CLRWDT` and `SLEEP` instructions clear the WDT and postscaler counts when executed.

**2:** When a `CLRWDT` instruction is executed, the postscaler count will be cleared.

### 26.2.1 CONTROL REGISTER

The WDTCON register ([Register 26-9](#)) is a readable and writable register. The `SWDTEN` bit enables or disables WDT operation. This allows software to override the `WDTEN` Configuration bit and enable the WDT only if it has been disabled by the Configuration bit.

**FIGURE 26-1: WDT BLOCK DIAGRAM**



## REGISTER 26-9: WDTCON: WATCHDOG TIMER CONTROL REGISTER

R/W-0	U-0	U-0	U-0	U-0	U-0	U-0	R/W-0
REGSLP <sup>(1)</sup>	—	—	—	—	—	—	SWDTEN <sup>(2)</sup>
bit 7							bit 0

**Legend:**

R = Readable bit                      W = Writable bit                      U = Unimplemented bit, read as '0'  
 -n = Value at POR                      '1' = Bit is set                      '0' = Bit is cleared                      x = Bit is unknown

- bit 7            **REGSLP:** Voltage Regulator Low-Power Operation Enable bit<sup>(1)</sup>  
                   1 = On-chip regulator enters low-power operation when device enters Sleep mode  
                   0 = On-chip regulator continues to operate normally in Sleep mode
- bit 6-1        **Unimplemented:** Read as '0'
- bit 0            **SWDTEN:** Software Controlled Watchdog Timer Enable bit<sup>(2)</sup>  
                   1 = Watchdog Timer is on  
                   0 = Watchdog Timer is off

- Note 1:** The REGSLP bit is automatically cleared when a Low-Voltage Detect condition occurs.  
**Note 2:** This bit has no effect if the Configuration bit, WDTEN, is enabled.

**TABLE 26-3: SUMMARY OF WATCHDOG TIMER REGISTERS**

Name	Bit 7	Bit 6	Bit 5	Bit 4	Bit 3	Bit 2	Bit 1	Bit 0	Reset Values on page
RCON	IPEN	—	$\overline{CM}$	$\overline{RI}$	$\overline{TO}$	$\overline{PD}$	$\overline{POR}$	$\overline{BOR}$	46
WDTCON	REGSLP	—	—	—	—	—	—	SWDTEN	46

Legend: — = unimplemented, read as '0'. Shaded cells are not used by the Watchdog Timer.

# PIC18F87J72

## 26.3 On-Chip Voltage Regulator

All of the PIC18F87J72 family devices power their core digital logic at a nominal 2.5V. For designs that are required to operate at a higher typical voltage, such as 3.3V, all devices in the PIC18F87J72 family incorporate an on-chip regulator that allows the device to run its core logic from VDD.

The regulator is controlled by the ENVREG pin. Tying VDD to the pin enables the regulator, which in turn, provides power to the core from the other VDD pins. When the regulator is enabled, a low-ESR filter capacitor must be connected to the VDDCORE/VCAP pin (Figure 26-2). This helps to maintain the stability of the regulator. The recommended value for the filter capacitor is provided in [Section 29.2 “DC Characteristics: PIC18F87J72 Family \(Industrial\)”](#).

If ENVREG is tied to VSS, the regulator is disabled. In this case, separate power for the core logic, at a nominal 2.5V, must be supplied to the device on the VDDCORE/VCAP pin to run the I/O pins at higher voltage levels, typically 3.3V. Alternatively, the VDDCORE/VCAP and VDD pins can be tied together to operate at a lower nominal voltage. Refer to Figure 26-2 for possible configurations.

### 26.3.1 VOLTAGE REGULATION AND LOW-VOLTAGE DETECTION

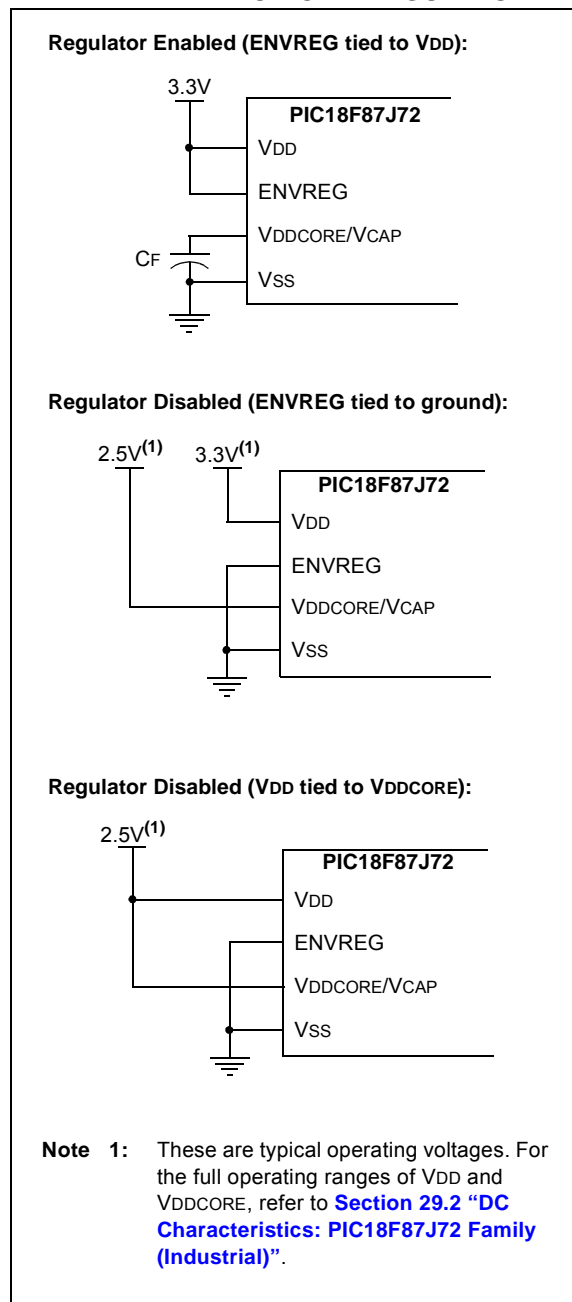
When it is enabled, the on-chip regulator provides a constant voltage of 2.5V nominal to the digital core logic. The regulator can provide this level from a VDD of about 2.5V, all the way up to the device's VDDMAX. It does not have the capability to boost VDD levels below 2.5V.

In order to prevent “brown-out” conditions, when the voltage drops too low for the regulator, the regulator enters Tracking mode. In Tracking mode, the regulator output follows VDD, with a typical voltage drop of 100 mV.

The on-chip regulator includes a simple Low-Voltage Detect (LVD) circuit. If VDD drops too low to maintain approximately 2.45V on VDDCORE, the circuit sets the Low-Voltage Detect Interrupt Flag, LVDIF (PIR2<2>), and clears the REGSLP (WDTCON<7>) bit if it was set.

This can be used to generate an interrupt and puts the application into a low-power operational mode or triggers an orderly shutdown. Low-Voltage Detection is only available when the regulator is enabled.

FIGURE 26-2: CONNECTIONS FOR THE ON-CHIP REGULATOR



## 26.3.2 ON-CHIP REGULATOR AND BOR

When the on-chip regulator is enabled, PIC18F87J72 family devices also have a simple Brown-out Reset capability. If the voltage supplied to the regulator falls to a level that is inadequate to maintain a regulated output for full-speed operation, the regulator Reset circuitry will generate a Brown-out Reset. This event is captured by the  $\overline{\text{BOR}}$  flag bit (RCON<0>).

The operation of the BOR is described in more detail in [Section 5.4 “Brown-out Reset \(BOR\)”](#) and [Section 5.4.1 “Detecting BOR”](#).

## 26.3.3 POWER-UP REQUIREMENTS

The on-chip regulator is designed to meet the power-up requirements for the device. If the application does not use the regulator, then strict power-up conditions must be adhered to. While powering up, VDDCORE must never exceed VDD by 0.3 volts.

## 26.3.4 OPERATION IN SLEEP MODE

When enabled, the on-chip regulator always consumes a small incremental amount of current over IDD. This includes when the device is in Sleep mode, even though the core digital logic does not require power. To provide additional savings in applications where power resources are critical, the regulator can be configured to automatically disable itself whenever the device goes into Sleep mode. This feature is controlled by the REGSLP bit (WDTCON<7>). Setting this bit disables the regulator in Sleep mode and reduces its current consumption to a minimum.

Substantial Sleep mode power savings can be obtained by setting the REGSLP bit, but device wake-up time will increase in order to ensure the regulator has enough time to stabilize.

The REGSLP bit is automatically cleared by hardware when a Low-Voltage Detect condition occurs. The REGSLP bit can be set again in software, which would continue to keep the voltage regulator in Low-Power mode. This, however, is not recommended if any write operations to the Flash will be performed.

## 26.4 Two-Speed Start-up

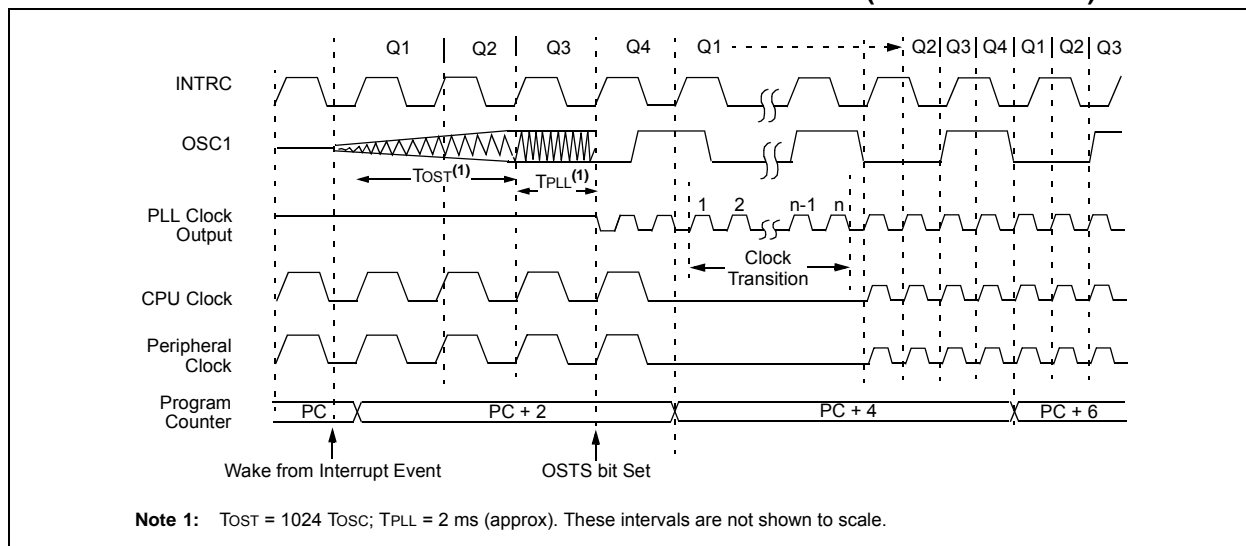
The Two-Speed Start-up feature helps to minimize the latency period, from oscillator start-up to code execution, by allowing the microcontroller to use the INTRC oscillator as a clock source until the primary clock source is available. It is enabled by setting the IESO Configuration bit.

Two-Speed Start-up should be enabled only if the primary oscillator mode is HS or HSPLL (Crystal-Based) modes. Since the EC and ECPLL modes do not require an OST start-up delay, Two-Speed Start-up should be disabled.

When enabled, Resets and wake-ups from Sleep mode cause the device to configure itself to run from the internal oscillator block as the clock source, following the time-out of the Power-up Timer after a Power-on Reset is enabled. This allows almost immediate code execution while the primary oscillator starts and the OST is running. Once the OST times out, the device automatically switches to PRI\_RUN mode.

In all other power-managed modes, Two-Speed Start-up is not used. The device will be clocked by the currently selected clock source until the primary clock source becomes available. The setting of the IESO bit is ignored.

**FIGURE 26-3: TIMING TRANSITION FOR TWO-SPEED START-UP (INTRC TO HSPLL)**



## 26.4.1 SPECIAL CONSIDERATIONS FOR USING TWO-SPEED START-UP

While using the INTRC oscillator in Two-Speed Start-up, the device still obeys the normal command sequences for entering power-managed modes, including serial `SLEEP` instructions (refer to [Section 4.1.4 “Multiple Sleep Commands”](#)). In practice, this means that user code can change the `SCS<1:0>` bit settings or issue `SLEEP` instructions before the OST times out. This would allow an application to briefly wake-up, perform routine “housekeeping” tasks and return to Sleep before the device starts to operate from the primary oscillator.

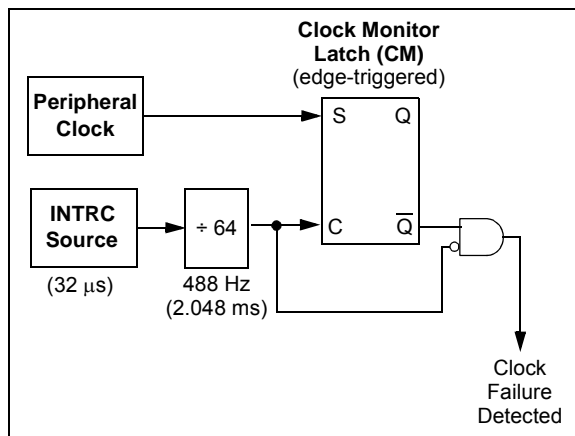
User code can also check if the primary clock source is currently providing the device clocking by checking the status of the OSTS bit (`OSCCON<3>`). If the bit is set, the primary oscillator is providing the clock. Otherwise, the internal oscillator block is providing the clock during wake-up from Reset or Sleep mode.

## 26.5 Fail-Safe Clock Monitor

The Fail-Safe Clock Monitor (FSCM) allows the microcontroller to continue operation in the event of an external oscillator failure by automatically switching the device clock to the internal oscillator block. The FSCM function is enabled by setting the `FCMEN` Configuration bit.

When FSCM is enabled, the INTRC oscillator runs at all times to monitor clocks to peripherals and provides a backup clock in the event of a clock failure. Clock monitoring (shown in [Figure 26-4](#)) is accomplished by creating a sample clock signal, which is the INTRC output divided by 64. This allows ample time between FSCM sample clocks for a peripheral clock edge to occur. The peripheral device clock and the sample clock are presented as inputs to the Clock Monitor (CM) latch. The CM is set on the falling edge of the device clock source but cleared on the rising edge of the sample clock.

**FIGURE 26-4: FSCM BLOCK DIAGRAM**



Clock failure is tested for on the falling edge of the sample clock. If a sample clock falling edge occurs while CM is still set, a clock failure has been detected ([Figure 26-5](#)). This causes the following:

- the FSCM generates an oscillator fail interrupt by setting bit, `OSCFIF` (`PIR2<7>`);
- the device clock source is switched to the internal oscillator block (`OSCCON` is not updated to show the current clock source – this is the fail-safe condition); and
- the WDT is reset.

During switchover, the postscaler frequency from the internal oscillator block may not be sufficiently stable for timing-sensitive applications. In these cases, it may be desirable to select another clock configuration and enter an alternate power-managed mode. This can be done to attempt a partial recovery or execute a controlled shutdown. See [Section 4.1.4 “Multiple Sleep Commands”](#) and [Section 26.4.1 “Special Considerations for Using Two-Speed Start-up”](#) for more details.

The FSCM will detect failures of the primary or secondary clock sources only. If the internal oscillator block fails, no failure would be detected, nor would any action be possible.

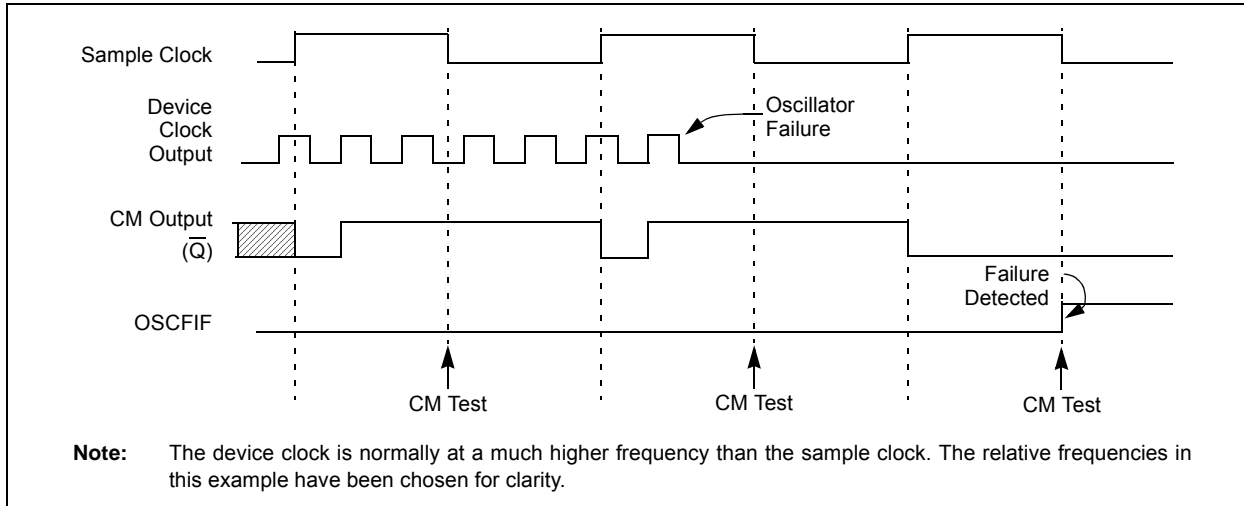
### 26.5.1 FSCM AND THE WATCHDOG TIMER

Both the FSCM and the WDT are clocked by the INTRC oscillator. Since the WDT operates with a separate divider and counter, disabling the WDT has no effect on the operation of the INTRC oscillator when the FSCM is enabled.

As already noted, the clock source is switched to the INTRC clock when a clock failure is detected. This may mean a substantial change in the speed of code execution. If the WDT is enabled with a small prescale value, a decrease in clock speed allows a WDT time-out to occur and a subsequent device Reset. For this reason, Fail-Safe Clock Monitor events also reset the WDT and postscaler, allowing it to start timing from when execution speed was changed and decreasing the likelihood of an erroneous time-out.

If the interrupt is disabled, subsequent interrupts while in Idle mode will cause the CPU to begin executing instructions while being clocked by the INTRC source.

**FIGURE 26-5: FSCM TIMING DIAGRAM**



## 26.5.2 EXITING FAIL-SAFE OPERATION

The fail-safe condition is terminated by either a device Reset or by entering a power-managed mode. On Reset, the controller starts the primary clock source specified in Configuration Register 2H (with any required start-up delays that are required for the oscillator mode, such as OST or PLL timer). The INTRC oscillator provides the device clock until the primary clock source becomes ready (similar to a Two-Speed Start-up). The clock source is then switched to the primary clock (indicated by the OSTS bit in the OSCCON register becoming set). The Fail-Safe Clock Monitor then resumes monitoring the peripheral clock.

The primary clock source may never become ready during start-up. In this case, operation is clocked by the INTOSC multiplexer. The OSCCON register will remain in its Reset state until a power-managed mode is entered.

## 26.5.3 FSCM INTERRUPTS IN POWER-MANAGED MODES

By entering a power-managed mode, the clock multiplexer selects the clock source selected by the OSCCON register. Fail-Safe Clock Monitoring of the power-managed clock source resumes in the power-managed mode.

If an oscillator failure occurs during power-managed operation, the subsequent events depend on whether or not the oscillator failure interrupt is enabled. If enabled (OSCFIF = 1), code execution will be clocked by the INTRC multiplexer. An automatic transition back to the failed clock source will not occur.

## 26.5.4 POR OR WAKE-UP FROM SLEEP

The FSCM is designed to detect oscillator failure at any point after the device has exited Power-on Reset (POR) or low-power Sleep mode. When the primary device clock is either EC or INTRC mode, monitoring can begin immediately following these events.

For HS or HSPLL modes, the situation is somewhat different. Since the oscillator may require a start-up time considerably longer than the FSCM sample clock time, a false clock failure may be detected. To prevent this, the internal oscillator block is automatically configured as the device clock and functions until the primary clock is stable (the OST and PLL timers have timed out). This is identical to Two-Speed Start-up mode. Once the primary clock is stable, the INTRC returns to its role as the FSCM source.

**Note:** The same logic that prevents false oscillator failure interrupts on POR, or wake from Sleep, will also prevent the detection of the oscillator's failure to start at all following these events. This can be avoided by monitoring the OSTS bit and using a timing routine to determine if the oscillator is taking too long to start. Even so, no oscillator failure interrupt will be flagged.

As noted in [Section 26.4.1 "Special Considerations for Using Two-Speed Start-up"](#), it is also possible to select another clock configuration and enter an alternate power-managed mode while waiting for the primary clock to become stable. When the new power-managed mode is selected, the primary clock is disabled.

# PIC18F87J72

---

## 26.6 Program Verification and Code Protection

For all devices in the PIC18F87J72 family of devices, the on-chip program memory space is treated as a single block. Code protection for this block is controlled by one Configuration bit, CP0. This bit inhibits external reads and writes to the program memory space. It has no direct effect in normal execution mode.

### 26.6.1 CONFIGURATION REGISTER PROTECTION

The Configuration registers are protected against untoward changes or reads in two ways. The primary protection is the write-once feature of the Configuration bits, which prevents reconfiguration once the bit has been programmed during a power cycle. To safeguard against unpredictable events, Configuration bit changes resulting from individual cell-level disruptions (such as ESD events) will cause a parity error and trigger a device Reset.

The data for the Configuration registers is derived from the Flash Configuration Words in program memory. When the CP0 bit set, the source data for device configuration is also protected as a consequence.

## 26.7 In-Circuit Serial Programming

PIC18F87J72 family microcontrollers can be serially programmed while in the end application circuit. This is simply done with two lines for clock and data, and three other lines for power, ground and the programming voltage. This allows customers to manufacture boards with unprogrammed devices and then program the microcontroller just before shipping the product. This also allows the most recent firmware or a custom firmware to be programmed.

## 26.8 In-Circuit Debugger

When the  $\overline{\text{DEBUG}}$  Configuration bit is programmed to a '0', the In-Circuit Debugger functionality is enabled. This function allows simple debugging functions when used with MPLAB<sup>®</sup> IDE. When the microcontroller has this feature enabled, some resources are not available for general use. [Table 26-4](#) shows which resources are required by the background debugger.

**TABLE 26-4: DEBUGGER RESOURCES**

I/O Pins:	RB6, RB7
Stack:	2 levels
Program Memory:	512 bytes
Data Memory:	10 bytes



## 27.0 INSTRUCTION SET SUMMARY

The PIC18F87J72 family of devices incorporates the standard set of 75 PIC18 core instructions, as well as an extended set of 8 new instructions for the optimization of code that is recursive or that utilizes a software stack. The extended set is discussed later in this section.

### 27.1 Standard Instruction Set

The standard PIC18 MCU instruction set adds many enhancements to the previous PIC<sup>®</sup> MCU instruction sets, while maintaining an easy migration from these PIC MCU instruction sets. Most instructions are a single program memory word (16 bits), but there are four instructions that require two program memory locations.

Each single-word instruction is a 16-bit word divided into an opcode, which specifies the instruction type and one or more operands, which further specify the operation of the instruction.

The instruction set is highly orthogonal and is grouped into four basic categories:

- **Byte-oriented** operations
- **Bit-oriented** operations
- **Literal** operations
- **Control** operations

The PIC18 instruction set summary in [Table 27-2](#) lists **byte-oriented**, **bit-oriented**, **literal** and **control** operations. [Table 27-1](#) shows the opcode field descriptions.

Most **byte-oriented** instructions have three operands:

1. The file register (specified by 'f')
2. The destination of the result (specified by 'd')
3. The accessed memory (specified by 'a')

The file register designator, 'f', specifies which file register is to be used by the instruction. The destination designator, 'd', specifies where the result of the operation is to be placed. If 'd' is zero, the result is placed in the WREG register. If 'd' is one, the result is placed in the file register specified in the instruction.

All **bit-oriented** instructions have three operands:

1. The file register (specified by 'f')
2. The bit in the file register (specified by 'b')
3. The accessed memory (specified by 'a')

The bit field designator, 'b', selects the number of the bit affected by the operation, while the file register designator, 'f', represents the number of the file in which the bit is located.

The **literal** instructions may use some of the following operands:

- A literal value to be loaded into a file register (specified by 'k')
- The desired FSR register to load the literal value into (specified by 'f')
- No operand required (specified by '—')

The **control** instructions may use some of the following operands:

- A program memory address (specified by 'n')
- The mode of the `CALL` or `RETURN` instructions (specified by 's')
- The mode of the table read and table write instructions (specified by 'm')
- No operand required (specified by '—')

All instructions are a single word, except for four double-word instructions. These instructions were made double-word to contain the required information in 32 bits. In the second word, the 4 MSBs are '1's. If this second word is executed as an instruction (by itself), it will execute as a `NOP`.

All single-word instructions are executed in a single instruction cycle, unless a conditional test is true or the program counter is changed as a result of the instruction. In these cases, the execution takes two instruction cycles with the additional instruction cycle(s) executed as a `NOP`.

The double-word instructions execute in two instruction cycles.

One instruction cycle consists of four oscillator periods. Thus, for an oscillator frequency of 4 MHz, the normal instruction execution time is 1  $\mu$ s. If a conditional test is true, or the program counter is changed as a result of an instruction, the instruction execution time is 2  $\mu$ s. Two-word branch instructions (if true) would take 3  $\mu$ s.

[Figure 27-1](#) shows the general formats that the instructions can have. All examples use the convention 'nnh' to represent a hexadecimal number.

The Instruction Set Summary, shown in [Table 27-2](#), lists the standard instructions recognized by the Microchip MPASM<sup>™</sup> Assembler.

[Section 27.1.1 "Standard Instruction Set"](#) provides a description of each instruction.

# PIC18F87J72

**TABLE 27-1: OPCODE FIELD DESCRIPTIONS**

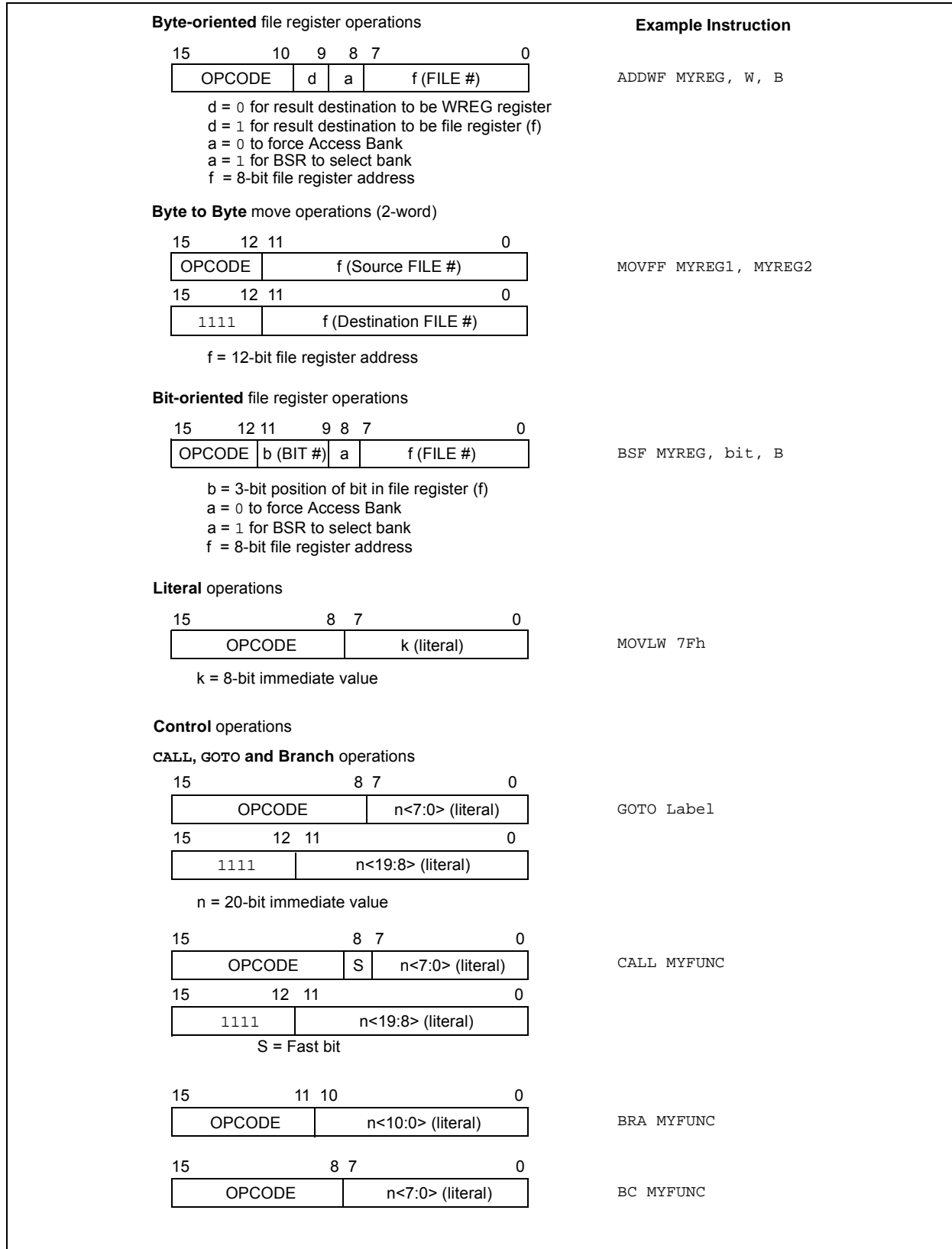
Field	Description
a	RAM access bit: a = 0: RAM location in Access RAM (BSR register is ignored) a = 1: RAM bank is specified by BSR register
bbb	Bit address within an 8-bit file register (0 to 7).
BSR	Bank Select Register. Used to select the current RAM bank.
C, DC, Z, OV, N	ALU Status bits: <b>C</b> arry, <b>D</b> igit <b>C</b> arry, <b>Z</b> ero, <b>O</b> verflow, <b>N</b> egative.
d	Destination select bit: d = 0: store result in WREG d = 1: store result in file register f
dest	Destination: either the WREG register or the specified register file location.
f	8-bit register file address (00h to FFh), or 2-bit FSR designator (0h to 3h).
f <sub>s</sub>	12-bit register file address (000h to FFFh). This is the source address.
f <sub>d</sub>	12-bit register file address (000h to FFFh). This is the destination address.
GIE	Global Interrupt Enable bit.
k	Literal field, constant data or label (may be either an 8-bit, 12-bit or a 20-bit value).
label	Label name.
mmm	The mode of the TBLPTR register for the table read and table write instructions. Only used with table read and table write instructions:
*	No Change to register (such as TBLPTR with table reads and writes)
*+	Post-Increment register (such as TBLPTR with table reads and writes)
*-	Post-Decrement register (such as TBLPTR with table reads and writes)
+*	Pre-Increment register (such as TBLPTR with table reads and writes)
n	The relative address (2's complement number) for relative branch instructions or the direct address for Call/Branch and Return instructions.
PC	Program Counter.
PCL	Program Counter Low Byte.
PCH	Program Counter High Byte.
PCLATH	Program Counter High Byte Latch.
PCLATU	Program Counter Upper Byte Latch.
$\overline{PD}$	Power-Down bit.
PRODH	Product of Multiply High Byte.
PRODL	Product of Multiply Low Byte.
s	Fast Call/Return mode select bit: s = 0: do not update into/from shadow registers s = 1: certain registers loaded into/from shadow registers (Fast mode)
TBLPTR	21-bit Table Pointer (points to a Program Memory location).
TABLAT	8-bit Table Latch.
T $\overline{O}$	Time-out bit.
TOS	Top-of-Stack.
u	Unused or Unchanged.
WDT	Watchdog Timer.
WREG	Working register (accumulator).
x	Don't care ('0' or '1'). The assembler will generate code with x = 0. It is the recommended form of use for compatibility with all Microchip software tools.
z <sub>s</sub>	7-bit offset value for Indirect Addressing of register files (source).
z <sub>d</sub>	7-bit offset value for Indirect Addressing of register files (destination).
{ }	Optional argument.
[text]	Indicates an Indexed Address.
(text)	The contents of text.

**TABLE 27-1: OPCODE FIELD DESCRIPTIONS (CONTINUED)**

<b>Field</b>	<b>Description</b>
[ <i>expr</i> ]< <i>n</i> >	Specifies bit <i>n</i> of the register indicated by the pointer <i>expr</i> .
→	Assigned to.
< >	Register bit field.
∈	In the set of.
<i>italics</i>	User-defined term (font is Courier New).

# PIC18F87J72

**FIGURE 27-1: GENERAL FORMAT FOR INSTRUCTIONS**



**TABLE 27-2: PIC18F87J72 FAMILY INSTRUCTION SET**

Mnemonic, Operands	Description	Cycles	16-Bit Instruction Word				Status Affected	Notes	
			MSb			LSb			
<b>BYTE-ORIENTED OPERATIONS</b>									
ADDWF	f, d, a	Add WREG and f	1	0010	01da	ffff	ffff	C, DC, Z, OV, N	1, 2
ADDWFC	f, d, a	Add WREG and Carry bit to f	1	0010	00da	ffff	ffff	C, DC, Z, OV, N	1, 2
ANDWF	f, d, a	AND WREG with f	1	0001	01da	ffff	ffff	Z, N	1, 2
CLRF	f, a	Clear f	1	0110	101a	ffff	ffff	Z	2
COMF	f, d, a	Complement f	1	0001	11da	ffff	ffff	Z, N	1, 2
CPFSEQ	f, a	Compare f with WREG, Skip =	1 (2 or	0110	001a	ffff	ffff	None	4
CPFSGT	f, a	Compare f with WREG, Skip >	3)	0110	010a	ffff	ffff	None	4
CPFSLT	f, a	Compare f with WREG, Skip <	1 (2 or	0110	000a	ffff	ffff	None	1, 2
DECf	f, d, a	Decrement f	3)	0000	01da	ffff	ffff	C, DC, Z, OV, N	1, 2, 3, 4
DECFSZ	f, d, a	Decrement f, Skip if 0	1 (2 or	0010	11da	ffff	ffff	None	1, 2, 3, 4
DCFSNZ	f, d, a	Decrement f, Skip if Not 0	3)	0100	11da	ffff	ffff	None	1, 2
INCF	f, d, a	Increment f	1	0010	10da	ffff	ffff	C, DC, Z, OV, N	1, 2, 3, 4
INCFSZ	f, d, a	Increment f, Skip if 0	1 (2 or	0011	11da	ffff	ffff	None	4
INFSNZ	f, d, a	Increment f, Skip if Not 0	3)	0100	10da	ffff	ffff	None	1, 2
IORWF	f, d, a	Inclusive OR WREG with f	1 (2 or	0001	00da	ffff	ffff	Z, N	1, 2
MOVF	f, d, a	Move f	3)	0101	00da	ffff	ffff	Z, N	1
MOVFF	f <sub>s</sub> , f <sub>d</sub>	Move f <sub>s</sub> (source) to f <sub>d</sub> (destination)	1 (2 or	1100	ffff	ffff	ffff	None	
MOVWF	f, a	Move WREG to f	3)	0110	111a	ffff	ffff	None	
MULWF	f, a	Multiply WREG with f	1 (2 or	0000	001a	ffff	ffff	None	1, 2
NEGF	f, a	Negate f	3)	0110	110a	ffff	ffff	C, DC, Z, OV, N	
RLCF	f, d, a	Rotate Left f through Carry	1	0011	01da	ffff	ffff	C, Z, N	1, 2
RLNCF	f, d, a	Rotate Left f (No Carry)	1	0100	01da	ffff	ffff	Z, N	
RRCF	f, d, a	Rotate Right f through Carry	2	0011	00da	ffff	ffff	C, Z, N	
RRNCF	f, d, a	Rotate Right f (No Carry)	1	0100	00da	ffff	ffff	Z, N	
SETF	f, a	Set f	1	0110	100a	ffff	ffff	None	1, 2
SUBFWB	f, d, a	Subtract f from WREG with Borrow	1	0101	01da	ffff	ffff	C, DC, Z, OV, N	
SUBWF	f, d, a	Subtract WREG from f	1	0101	11da	ffff	ffff	C, DC, Z, OV, N	1, 2
SUBWFB	f, d, a	Subtract WREG from f with Borrow	1	0101	10da	ffff	ffff	C, DC, Z, OV, N	
SWAPF	f, d, a	Swap Nibbles in f	1	0011	10da	ffff	ffff	None	4
TSTFSZ	f, a	Test f, Skip if 0	1	0110	011a	ffff	ffff	None	1, 2
XORWF	f, d, a	Exclusive OR WREG with f	1	0001	10da	ffff	ffff	Z, N	
			1						
			1						
			1						
			1 (2 or						
			3)						
			1						

- Note 1:** When a PORT register is modified as a function of itself (e.g., `MOVF PORTB, 1, 0`), the value used will be that value present on the pins themselves. For example, if the data latch is '1' for a pin configured as input and is driven low by an external device, the data will be written back with a '0'.
- If this instruction is executed on the TMR0 register (and, where applicable, d = 1), the prescaler will be cleared if assigned.
  - If the Program Counter (PC) is modified or a conditional test is true, the instruction requires two cycles. The second cycle is executed as a NOP.
  - Some instructions are two-word instructions. The second word of these instructions will be executed as a NOP unless the first word of the instruction retrieves the information embedded in these 16 bits. This ensures that all program memory locations have a valid instruction.

# PIC18F87J72

**TABLE 27-2: PIC18F87J72 FAMILY INSTRUCTION SET (CONTINUED)**

Mnemonic, Operands	Description	Cycles	16-Bit Instruction Word				Status Affected	Notes	
			MSb			LSb			
<b>BIT-ORIENTED OPERATIONS</b>									
BCF	f, b, a	Bit Clear f	1	1001	bbba	ffff	ffff	None	1, 2
BSF	f, b, a	Bit Set f	1	1000	bbba	ffff	ffff	None	1, 2
BTFSC	f, b, a	Bit Test f, Skip if Clear	1 (2 or 3)	1011	bbba	ffff	ffff	None	3, 4
BTFSS	f, b, a	Bit Test f, Skip if Set	1 (2 or 3)	1010	bbba	ffff	ffff	None	3, 4
BTG	f, b, a	Bit Toggle f	1	0111	bbba	ffff	ffff	None	1, 2
<b>CONTROL OPERATIONS</b>									
BC	n	Branch if Carry	1 (2)	1110	0010	nnnn	nnnn	None	
BN	n	Branch if Negative	1 (2)	1110	0110	nnnn	nnnn	None	
BNC	n	Branch if Not Carry	1 (2)	1110	0011	nnnn	nnnn	None	
BNN	n	Branch if Not Negative	1 (2)	1110	0111	nnnn	nnnn	None	
BNOV	n	Branch if Not Overflow	1 (2)	1110	0101	nnnn	nnnn	None	
BNZ	n	Branch if Not Zero	1 (2)	1110	0001	nnnn	nnnn	None	
BOV	n	Branch if Overflow	1 (2)	1110	0100	nnnn	nnnn	None	
BRA	n	Branch Unconditionally	2	1101	0nnn	nnnn	nnnn	None	
BZ	n	Branch if Zero	1 (2)	1110	0000	nnnn	nnnn	None	
CALL	n, s	Call Subroutine	2	1110	110s	kkkk	kkkk	None	
		1st word							
		2nd word		1111	kkkk	kkkk	kkkk		
CLRWDT	—	Clear Watchdog Timer	1	0000	0000	0000	0100	$\overline{TO}$ , $\overline{PD}$	
DAW	—	Decimal Adjust WREG	1	0000	0000	0000	0111	C	
GOTO	n	Go to Address	2	1110	1111	kkkk	kkkk	None	
		1st word							
		2nd word		1111	kkkk	kkkk	kkkk		
NOP	—	No Operation	1	0000	0000	0000	0000	None	
NOP	—	No Operation	1	1111	xxxx	xxxx	xxxx	None	4
POP	—	Pop Top of Return Stack (TOS)	1	0000	0000	0000	0110	None	
PUSH	—	Push Top of Return Stack (TOS)	1	0000	0000	0000	0101	None	
RCALL	n	Relative Call	2	1101	1nnn	nnnn	nnnn	None	
RESET	—	Software Device Reset	1	0000	0000	1111	1111	All	
RETFIE	s	Return from Interrupt Enable	2	0000	0000	0001	000s	GIE/GIEH, PEIE/GIEL	
RETLW	k	Return with Literal in WREG	2	0000	1100	kkkk	kkkk	None	
RETURN	s	Return from Subroutine	2	0000	0000	0001	001s	None	
SLEEP	—	Go into Standby mode	1	0000	0000	0000	0011	$\overline{TO}$ , $\overline{PD}$	

- Note 1:** When a PORT register is modified as a function of itself (e.g., `MOVF PORTB, 1, 0`), the value used will be that value present on the pins themselves. For example, if the data latch is '1' for a pin configured as input and is driven low by an external device, the data will be written back with a '0'.
- 2:** If this instruction is executed on the TMR0 register (and, where applicable,  $d = 1$ ), the prescaler will be cleared if assigned.
- 3:** If the Program Counter (PC) is modified or a conditional test is true, the instruction requires two cycles. The second cycle is executed as a `NOP`.
- 4:** Some instructions are two-word instructions. The second word of these instructions will be executed as a `NOP` unless the first word of the instruction retrieves the information embedded in these 16 bits. This ensures that all program memory locations have a valid instruction.

**TABLE 27-2: PIC18F87J72 FAMILY INSTRUCTION SET (CONTINUED)**

Mnemonic, Operands	Description	Cycles	16-Bit Instruction Word				Status Affected	Notes
			MSb			LSb		
<b>LITERAL OPERATIONS</b>								
ADDLW	k	Add Literal and WREG	1	0000	1111	kkkk	kkkk	C, DC, Z, OV, N
ANDLW	k	AND Literal with WREG	1	0000	1011	kkkk	kkkk	Z, N
IORLW	k	Inclusive OR Literal with WREG	1	0000	1001	kkkk	kkkk	Z, N
LFSR	f, k	Move literal (12-bit) 2nd word to FSR(f) 1st word	2	1110	1110	00ff	kkkk	None
MOVLB	k	Move Literal to BSR<3:0>	1	0000	0001	0000	kkkk	None
MOVLW	k	Move Literal to WREG	1	0000	1110	kkkk	kkkk	None
MULLW	k	Multiply Literal with WREG	1	0000	1101	kkkk	kkkk	None
RETLW	k	Return with Literal in WREG	2	0000	1100	kkkk	kkkk	None
SUBLW	k	Subtract WREG from Literal	1	0000	1000	kkkk	kkkk	C, DC, Z, OV, N
XORLW	k	Exclusive OR Literal with WREG	1	0000	1010	kkkk	kkkk	Z, N
<b>DATA MEMORY ↔ PROGRAM MEMORY OPERATIONS</b>								
TBLRD*		Table Read	2	0000	0000	0000	1000	None
TBLRD*+		Table Read with Post-Increment		0000	0000	0000	1001	None
TBLRD*-		Table Read with Post-Decrement		0000	0000	0000	1010	None
TBLRD+*		Table Read with Pre-Increment		0000	0000	0000	1011	None
TBLWT*		Table Write	2	0000	0000	0000	1100	None
TBLWT*+		Table Write with Post-Increment		0000	0000	0000	1101	None
TBLWT*-		Table Write with Post-Decrement		0000	0000	0000	1110	None
TBLWT+*		Table Write with Pre-Increment		0000	0000	0000	1111	None

- Note 1:** When a PORT register is modified as a function of itself (e.g., `MOVF PORTB, 1, 0`), the value used will be that value present on the pins themselves. For example, if the data latch is '1' for a pin configured as input and is driven low by an external device, the data will be written back with a '0'.
- 2:** If this instruction is executed on the TMR0 register (and, where applicable,  $d = 1$ ), the prescaler will be cleared if assigned.
- 3:** If the Program Counter (PC) is modified or a conditional test is true, the instruction requires two cycles. The second cycle is executed as a `NOP`.
- 4:** Some instructions are two-word instructions. The second word of these instructions will be executed as a `NOP` unless the first word of the instruction retrieves the information embedded in these 16 bits. This ensures that all program memory locations have a valid instruction.

# PIC18F87J72

## 27.1.1 STANDARD INSTRUCTION SET

ADDLW	ADD Literal to W								
Syntax:	ADDLW k								
Operands:	$0 \leq k \leq 255$								
Operation:	$(W) + k \rightarrow W$								
Status Affected:	N, OV, C, DC, Z								
Encoding:	<table border="1"> <tr> <td>0000</td> <td>1111</td> <td>kkkk</td> <td>kkkk</td> </tr> </table>	0000	1111	kkkk	kkkk				
0000	1111	kkkk	kkkk						
Description:	The contents of W are added to the 8-bit literal 'k' and the result is placed in W.								
Words:	1								
Cycles:	1								
Q Cycle Activity:	<table border="1"> <thead> <tr> <th>Q1</th> <th>Q2</th> <th>Q3</th> <th>Q4</th> </tr> </thead> <tbody> <tr> <td>Decode</td> <td>Read literal 'k'</td> <td>Process Data</td> <td>Write to W</td> </tr> </tbody> </table>	Q1	Q2	Q3	Q4	Decode	Read literal 'k'	Process Data	Write to W
Q1	Q2	Q3	Q4						
Decode	Read literal 'k'	Process Data	Write to W						

**Example:** ADDLW 15h

Before Instruction  
W = 10h  
After Instruction  
W = 25h

ADDWF	ADD W to f								
Syntax:	ADDWF f{,d{,a}}								
Operands:	$0 \leq f \leq 255$ $d \in [0,1]$ $a \in [0,1]$								
Operation:	$(W) + (f) \rightarrow \text{dest}$								
Status Affected:	N, OV, C, DC, Z								
Encoding:	<table border="1"> <tr> <td>0010</td> <td>01da</td> <td>ffff</td> <td>ffff</td> </tr> </table>	0010	01da	ffff	ffff				
0010	01da	ffff	ffff						
Description:	Add W to register 'f'. If 'd' is '0', the result is stored in W. If 'd' is '1', the result is stored back in register 'f'.  If 'a' is '0', the Access Bank is selected. If 'a' is '1', the BSR is used to select the GPR bank.  If 'a' is '0' and the extended instruction set is enabled, this instruction operates in Indexed Literal Offset Addressing mode whenever $f \leq 95$ (5Fh). See <a href="#">Section 27.2.3 "Byte-Oriented and Bit-Oriented Instructions in Indexed Literal Offset Mode"</a> for details.								
Words:	1								
Cycles:	1								
Q Cycle Activity:	<table border="1"> <thead> <tr> <th>Q1</th> <th>Q2</th> <th>Q3</th> <th>Q4</th> </tr> </thead> <tbody> <tr> <td>Decode</td> <td>Read register 'f'</td> <td>Process Data</td> <td>Write to destination</td> </tr> </tbody> </table>	Q1	Q2	Q3	Q4	Decode	Read register 'f'	Process Data	Write to destination
Q1	Q2	Q3	Q4						
Decode	Read register 'f'	Process Data	Write to destination						

**Example:** ADDWF REG, 0, 0

Before Instruction  
W = 17h  
REG = 0C2h  
After Instruction  
W = 0D9h  
REG = 0C2h

**Note:** All PIC18 instructions may take an optional label argument preceding the instruction mnemonic for use in symbolic addressing. If a label is used, the instruction format then becomes: {label} instruction argument(s).



**ADDWFC**      **ADD W and Carry bit to f**

---

Syntax:            ADDWFC    f {,d {,a}}

Operands:         $0 \leq f \leq 255$   
 $d \in [0,1]$   
 $a \in [0,1]$

Operation:        (W) + (f) + (C) → dest

Status Affected: N,OV, C, DC, Z

Encoding:        

0010	00da	ffff	ffff
------	------	------	------

Description:     Add W, the Carry flag and data memory location 'f'. If 'd' is '0', the result is placed in W. If 'd' is '1', the result is placed in data memory location 'f'.  
 If 'a' is '0', the Access Bank is selected. If 'a' is '1', the BSR is used to select the GPR bank.  
 If 'a' is '0' and the extended instruction set is enabled, this instruction operates in Indexed Literal Offset Addressing mode whenever  $f \leq 95$  (5Fh). See [Section 27.2.3 "Byte-Oriented and Bit-Oriented Instructions in Indexed Literal Offset Mode"](#) for details.

Words:            1

Cycles:           1

Q Cycle Activity:

Q1	Q2	Q3	Q4
Decode	Read register 'f'	Process Data	Write to destination

Example:            ADDWFC    REG, 0, 1

Before Instruction  
 Carry bit = 1  
 REG = 02h  
 W = 4Dh

After Instruction  
 Carry bit = 0  
 REG = 02h  
 W = 50h

**ANDLW**            **AND Literal with W**

---

Syntax:            ANDLW    k

Operands:         $0 \leq k \leq 255$

Operation:        (W) .AND. k → W

Status Affected: N, Z

Encoding:        

0000	1011	kkkk	kkkk
------	------	------	------

Description:     The contents of W are ANDed with the 8-bit literal 'k'. The result is placed in W.

Words:            1

Cycles:           1

Q Cycle Activity:

Q1	Q2	Q3	Q4
Decode	Read literal 'k'	Process Data	Write to W

Example:            ANDLW    05Fh

Before Instruction  
 W = A3h

After Instruction  
 W = 03h

# PIC18F87J72

## ANDWF

### AND W with f

Syntax: ANDWF f{,d{,a}}

Operands:  $0 \leq f \leq 255$   
 $d \in [0,1]$   
 $a \in [0,1]$

Operation: (W) .AND. (f) → dest

Status Affected: N, Z

Encoding: 

0001	01da	ffff	ffff
------	------	------	------

Description: The contents of W are ANDed with register 'f'. If 'd' is '0', the result is stored in W. If 'd' is '1', the result is stored back in register 'f'.

If 'a' is '0', the Access Bank is selected. If 'a' is '1', the BSR is used to select the GPR bank.

If 'a' is '0' and the extended instruction set is enabled, this instruction operates in Indexed Literal Offset Addressing mode whenever  $f \leq 95$  (5Fh). See [Section 27.2.3 "Byte-Oriented and Bit-Oriented Instructions in Indexed Literal Offset Mode"](#) for details.

Words: 1

Cycles: 1

Q Cycle Activity:

Q1	Q2	Q3	Q4
Decode	Read register 'f'	Process Data	Write to destination

Example: ANDWF REG, 0, 0

Before Instruction  
W = 17h  
REG = C2h  
After Instruction  
W = 02h  
REG = C2h

## BC

### Branch if Carry

Syntax: BC n

Operands:  $-128 \leq n \leq 127$

Operation: if Carry bit is '1',  
(PC) + 2 + 2n → PC

Status Affected: None

Encoding: 

1110	0010	nnnn	nnnn
------	------	------	------

Description: If the Carry bit is '1', then the program will branch.

The 2's complement number '2n' is added to the PC. Since the PC will have incremented to fetch the next instruction, the new address will be PC + 2 + 2n. This instruction is then a 2-cycle instruction.

Words: 1

Cycles: 1(2)

Q Cycle Activity:

If Jump:

Q1	Q2	Q3	Q4
Decode	Read literal 'n'	Process Data	Write to PC
No operation	No operation	No operation	No operation

If No Jump:

Q1	Q2	Q3	Q4
Decode	Read literal 'n'	Process Data	No operation

Example: HERE BC 5

Before Instruction  
PC = address (HERE)  
After Instruction  
If Carry = 1;  
PC = address (HERE + 12)  
If Carry = 0;  
PC = address (HERE + 2)

**BCF**                      **Bit Clear f**

---

Syntax:                    BCF   f, b {,a}

Operands:                 $0 \leq f \leq 255$   
 $0 \leq b \leq 7$   
 $a \in [0,1]$

Operation:                 $0 \rightarrow f < b$

Status Affected:        None

Encoding:                

1001	bbba	ffff	ffff
------	------	------	------

Description:             Bit 'b' in register 'f' is cleared.  
  
If 'a' is '0', the Access Bank is selected.  
If 'a' is '1', the BSR is used to select the GPR bank.  
  
If 'a' is '0' and the extended instruction set is enabled, this instruction operates in Indexed Literal Offset Addressing mode whenever  $f \leq 95$  (5Fh). See [Section 27.2.3 "Byte-Oriented and Bit-Oriented Instructions in Indexed Literal Offset Mode"](#) for details.

Words:                    1

Cycles:                    1

Q Cycle Activity:

Q1	Q2	Q3	Q4
Decode	Read register 'f'	Process Data	Write register 'f'

Example:                BCF        FLAG\_REG, 7, 0

Before Instruction  
FLAG\_REG = C7h

After Instruction  
FLAG\_REG = 47h

**BN**                        **Branch if Negative**

---

Syntax:                    BN   n

Operands:                 $-128 \leq n \leq 127$

Operation:                if Negative bit is '1',  
 $(PC) + 2 + 2n \rightarrow PC$

Status Affected:        None

Encoding:                

1110	0110	nnnn	nnnn
------	------	------	------

Description:             If the Negative bit is '1', then the program will branch.  
  
The 2's complement number '2n' is added to the PC. Since the PC will have incremented to fetch the next instruction, the new address will be  $PC + 2 + 2n$ . This instruction is then a 2-cycle instruction.

Words:                    1

Cycles:                    1(2)

Q Cycle Activity:  
If Jump:

Q1	Q2	Q3	Q4
Decode	Read literal 'n'	Process Data	Write to PC
No operation	No operation	No operation	No operation

If No Jump:

Q1	Q2	Q3	Q4
Decode	Read literal 'n'	Process Data	No operation

Example:                               HERE                BN    Jump

Before Instruction  
PC                        =    address (HERE)

After Instruction  
If Negative                =    1;  
PC                        =    address (Jump)

If Negative                =    0;  
PC                        =    address (HERE + 2)

# PIC18F87J72

## BNC Branch if Not Carry

Syntax: BNC n  
 Operands:  $-128 \leq n \leq 127$   
 Operation: if Carry bit is '0',  
 $(PC) + 2 + 2n \rightarrow PC$   
 Status Affected: None  
 Encoding: 

1110	0011	nnnn	nnnn
------	------	------	------

  
 Description: If the Carry bit is '0', then the program will branch.  
 The 2's complement number '2n' is added to the PC. Since the PC will have incremented to fetch the next instruction, the new address will be  $PC + 2 + 2n$ . This instruction is then a 2-cycle instruction.  
 Words: 1  
 Cycles: 1(2)

Q Cycle Activity:  
 If Jump:

Q1	Q2	Q3	Q4
Decode	Read literal 'n'	Process Data	Write to PC
No operation	No operation	No operation	No operation

If No Jump:

Q1	Q2	Q3	Q4
Decode	Read literal 'n'	Process Data	No operation

Example:            HERE            BNC    Jump  
 Before Instruction  
 PC = address (HERE)  
 After Instruction  
 If Carry = 0;  
 PC = address (Jump)  
 If Carry = 1;  
 PC = address (HERE + 2)

## BNN Branch if Not Negative

Syntax: BNN n  
 Operands:  $-128 \leq n \leq 127$   
 Operation: if Negative bit is '0',  
 $(PC) + 2 + 2n \rightarrow PC$   
 Status Affected: None  
 Encoding: 

1110	0111	nnnn	nnnn
------	------	------	------

  
 Description: If the Negative bit is '0', then the program will branch.  
 The 2's complement number '2n' is added to the PC. Since the PC will have incremented to fetch the next instruction, the new address will be  $PC + 2 + 2n$ . This instruction is then a 2-cycle instruction.  
 Words: 1  
 Cycles: 1(2)

Q Cycle Activity:  
 If Jump:

Q1	Q2	Q3	Q4
Decode	Read literal 'n'	Process Data	Write to PC
No operation	No operation	No operation	No operation

If No Jump:

Q1	Q2	Q3	Q4
Decode	Read literal 'n'	Process Data	No operation

Example:            HERE            BNN    Jump  
 Before Instruction  
 PC = address (HERE)  
 After Instruction  
 If Negative = 0;  
 PC = address (Jump)  
 If Negative = 1;  
 PC = address (HERE + 2)

**BNOV**                      **Branch if Not Overflow**

---

Syntax:                      BNOV n

Operands:                   -128 ≤ n ≤ 127

Operation:                   if Overflow bit is '0',  
(PC) + 2 + 2n → PC

Status Affected:           None

Encoding:                   

1110	0101	nnnn	nnnn
------	------	------	------

Description:                   If the Overflow bit is '0', then the program will branch.

                                 The 2's complement number '2n' is added to the PC. Since the PC will have incremented to fetch the next instruction, the new address will be PC + 2 + 2n. This instruction is then a 2-cycle instruction.

Words:                           1

Cycles:                        1(2)

Q Cycle Activity:  
If Jump:

Q1	Q2	Q3	Q4
Decode	Read literal 'n'	Process Data	Write to PC
No operation	No operation	No operation	No operation

If No Jump:

Q1	Q2	Q3	Q4
Decode	Read literal 'n'	Process Data	No operation

Example:                      HERE                      BNOV Jump

Before Instruction  
PC                              =                      address (HERE)

After Instruction  
If Overflow                   =                      0;  
PC                              =                      address (Jump)

If Overflow                   =                      1;  
PC                              =                      address (HERE + 2)

**BNZ**                            **Branch if Not Zero**

---

Syntax:                        BNZ n

Operands:                   -128 ≤ n ≤ 127

Operation:                   if Zero bit is '0',  
(PC) + 2 + 2n → PC

Status Affected:           None

Encoding:                   

1110	0001	nnnn	nnnn
------	------	------	------

Description:                   If the Zero bit is '0', then the program will branch.

                                 The 2's complement number '2n' is added to the PC. Since the PC will have incremented to fetch the next instruction, the new address will be PC + 2 + 2n. This instruction is then a 2-cycle instruction.

Words:                           1

Cycles:                        1(2)

Q Cycle Activity:  
If Jump:

Q1	Q2	Q3	Q4
Decode	Read literal 'n'	Process Data	Write to PC
No operation	No operation	No operation	No operation

If No Jump:

Q1	Q2	Q3	Q4
Decode	Read literal 'n'	Process Data	No operation

Example:                      HERE                      BNZ Jump

Before Instruction  
PC                              =                      address (HERE)

After Instruction  
If Zero                        =                      0;  
PC                              =                      address (Jump)

If Zero                        =                      1;  
PC                              =                      address (HERE + 2)

# PIC18F87J72

## BRA Unconditional Branch

Syntax: BRA n

Operands:  $-1024 \leq n \leq 1023$

Operation:  $(PC) + 2 + 2n \rightarrow PC$

Status Affected: None

Encoding: 

1101	0nnn	nnnn	nnnn
------	------	------	------

Description: Add the 2's complement number '2n' to the PC. Since the PC will have incremented to fetch the next instruction, the new address will be  $PC + 2 + 2n$ . This instruction is a 2-cycle instruction.

Words: 1

Cycles: 2

Q Cycle Activity:

Q1	Q2	Q3	Q4
Decode	Read literal 'n'	Process Data	Write to PC
No operation	No operation	No operation	No operation

**Example:**           HERE           BRA   Jump

Before Instruction  
PC = address (HERE)

After Instruction  
PC = address (Jump)

## BSF Bit Set f

Syntax: BSF f, b {,a}

Operands:  $0 \leq f \leq 255$   
 $0 \leq b \leq 7$   
 $a \in [0,1]$

Operation:  $1 \rightarrow f<b>$

Status Affected: None

Encoding: 

1000	bbba	ffff	ffff
------	------	------	------

Description: Bit 'b' in register 'f' is set.  
If 'a' is '0', the Access Bank is selected.  
If 'a' is '1', the BSR is used to select the GPR bank.  
If 'a' is '0' and the extended instruction set is enabled, this instruction operates in Indexed Literal Offset Addressing mode whenever  $f \leq 95$  (5Fh). See [Section 27.2.3 "Byte-Oriented and Bit-Oriented Instructions in Indexed Literal Offset Mode"](#) for details.

Words: 1

Cycles: 1

Q Cycle Activity:

Q1	Q2	Q3	Q4
Decode	Read register 'f'	Process Data	Write register 'f'

**Example:**           BSF       FLAG\_REG, 7, 1

Before Instruction  
FLAG\_REG = 0Ah

After Instruction  
FLAG\_REG = 8Ah

**BTFSC**                      **Bit Test File, Skip if Clear**

---

Syntax:                      BTFSC f, b {,a}

Operands:                     $0 \leq f \leq 255$   
 $0 \leq b \leq 7$   
 $a \in [0,1]$

Operation:                    skip if (f<b>) = 0

Status Affected:            None

Encoding:                    

1011	bbba	ffff	ffff
------	------	------	------

Description:                    If bit 'b' in register 'f' is '0', then the next instruction is skipped. If bit 'b' is '0', then the next instruction fetched during the current instruction execution is discarded and a NOP is executed instead, making this a 2-cycle instruction.

                                  If 'a' is '0', the Access Bank is selected. If 'a' is '1', the BSR is used to select the GPR bank.

                                  If 'a' is '0' and the extended instruction set is enabled, this instruction operates in Indexed Literal Offset Addressing mode whenever  $f \leq 95$  (5Fh). See [Section 27.2.3 "Byte-Oriented and Bit-Oriented Instructions in Indexed Literal Offset Mode"](#) for details.

Words:                        1

Cycles:                        1(2)  
**Note:** 3 cycles if skip and followed by a 2-word instruction.

Q Cycle Activity:

Q1	Q2	Q3	Q4
Decode	Read register 'f'	Process Data	No operation

If skip:

Q1	Q2	Q3	Q4
No operation	No operation	No operation	No operation

If skip and followed by 2-word instruction:

Q1	Q2	Q3	Q4
No operation	No operation	No operation	No operation
No operation	No operation	No operation	No operation

**Example:**                    HERE    BTFSC    FLAG, 1, 0  
                                  FALSE    :  
                                  TRUE     :

Before Instruction  
PC                    =    address (HERE)

After Instruction  
If FLAG<1>        =    0;  
PC                    =    address (TRUE)  
If FLAG<1>        =    1;  
PC                    =    address (FALSE)

**BTFSS**                      **Bit Test File, Skip if Set**

---

Syntax:                      BTFSS f, b {,a}

Operands:                     $0 \leq f \leq 255$   
 $0 \leq b < 7$   
 $a \in [0,1]$

Operation:                    skip if (f<b>) = 1

Status Affected:            None

Encoding:                    

1010	bbba	ffff	ffff
------	------	------	------

Description:                    If bit 'b' in register 'f' is '1', then the next instruction is skipped. If bit 'b' is '1', then the next instruction fetched during the current instruction execution is discarded and a NOP is executed instead, making this a 2-cycle instruction.

                                  If 'a' is '0', the Access Bank is selected. If 'a' is '1', the BSR is used to select the GPR bank.

                                  If 'a' is '0' and the extended instruction set is enabled, this instruction operates in Indexed Literal Offset Addressing mode whenever  $f \leq 95$  (5Fh). See [Section 27.2.3 "Byte-Oriented and Bit-Oriented Instructions in Indexed Literal Offset Mode"](#) for details.

Words:                        1

Cycles:                        1(2)  
**Note:** 3 cycles if skip and followed by a 2-word instruction.

Q Cycle Activity:

Q1	Q2	Q3	Q4
Decode	Read register 'f'	Process Data	No operation

If skip:

Q1	Q2	Q3	Q4
No operation	No operation	No operation	No operation

If skip and followed by 2-word instruction:

Q1	Q2	Q3	Q4
No operation	No operation	No operation	No operation
No operation	No operation	No operation	No operation

**Example:**                    HERE    BTFSS    FLAG, 1, 0  
                                  FALSE    :  
                                  TRUE     :

Before Instruction  
PC                    =    address (HERE)

After Instruction  
If FLAG<1>        =    0;  
PC                    =    address (FALSE)  
If FLAG<1>        =    1;  
PC                    =    address (TRUE)

# PIC18F87J72

**BTG**                      **Bit Toggle f**

---

Syntax:                    BTG f, b {,a}

Operands:                 $0 \leq f \leq 255$   
 $0 \leq b < 7$   
 $a \in [0,1]$

Operation:                 $\overline{(f < b)} \rightarrow f < b$

Status Affected:        None

Encoding:                

0111	bbba	ffff	ffff
------	------	------	------

Description:             Bit 'b' in data memory location 'f' is inverted.

                              If 'a' is '0', the Access Bank is selected.  
                              If 'a' is '1', the BSR is used to select the GPR bank.

                              If 'a' is '0' and the extended instruction set is enabled, this instruction operates in Indexed Literal Offset Addressing mode whenever  $f \leq 95$  (5Fh). See [Section 27.2.3 "Byte-Oriented and Bit-Oriented Instructions in Indexed Literal Offset Mode"](#) for details.

Words:                    1

Cycles:                   1

Q Cycle Activity:

Q1	Q2	Q3	Q4
Decode	Read register 'f'	Process Data	Write register 'f'

Example:                BTG     PORTC, 4, 0

Before Instruction:  
PORTC = 0111 0101 [75h]

After Instruction:  
PORTC = 0110 0101 [65h]

**BOV**                      **Branch if Overflow**

---

Syntax:                    BOV n

Operands:                 $-128 \leq n \leq 127$

Operation:                if Overflow bit is '1',  
 $(PC) + 2 + 2n \rightarrow PC$

Status Affected:        None

Encoding:                

1110	0100	nnnn	nnnn
------	------	------	------

Description:             If the Overflow bit is '1', then the program will branch.

                              The 2's complement number '2n' is added to the PC. Since the PC will have incremented to fetch the next instruction, the new address will be  $PC + 2 + 2n$ . This instruction is then a 2-cycle instruction.

Words:                    1

Cycles:                   1(2)

Q Cycle Activity:  
If Jump:

Q1	Q2	Q3	Q4
Decode	Read literal 'n'	Process Data	Write to PC
No operation	No operation	No operation	No operation

If No Jump:

Q1	Q2	Q3	Q4
Decode	Read literal 'n'	Process Data	No operation

Example:                               HERE                BOV Jump

Before Instruction  
PC = address (HERE)

After Instruction  
If Overflow = 1;  
PC = address (Jump)  
If Overflow = 0;  
PC = address (HERE + 2)



**BZ**                      **Branch if Zero**

---

Syntax:                    BZ n

Operands:                -128 ≤ n ≤ 127

Operation:                if Zero bit is '1',  
(PC) + 2 + 2n → PC

Status Affected:        None

Encoding:                

1110	0000	nnnn	nnnn
------	------	------	------

Description:             If the Zero bit is '1', then the program will branch.

The 2's complement number '2n' is added to the PC. Since the PC will have incremented to fetch the next instruction, the new address will be PC + 2 + 2n. This instruction is then a 2-cycle instruction.

Words:                    1

Cycles:                    1(2)

Q Cycle Activity:  
If Jump:

Q1	Q2	Q3	Q4
Decode	Read literal 'n'	Process Data	Write to PC
No operation	No operation	No operation	No operation

If No Jump:

Q1	Q2	Q3	Q4
Decode	Read literal 'n'	Process Data	No operation
No operation	No operation	No operation	No operation

Example:                           HERE            BZ    Jump

Before Instruction  
PC                    =    address (HERE)

After Instruction  
If Zero                =    1;  
PC                    =    address (Jump)

If Zero                =    0;  
PC                    =    address (HERE + 2)

**CALL**                    **Subroutine Call**

---

Syntax:                    CALL k {,s}

Operands:                0 ≤ k ≤ 1048575  
s ∈ [0,1]

Operation:                (PC) + 4 → TOS,  
k → PC<20:1>;  
if s = 1  
(W) → WS,  
(STATUS) → STATUSS,  
(BSR) → BSRS

Status Affected:        None

Encoding:                

1110	110s	k <sub>7</sub> kkk	kkkk <sub>0</sub>
1111	k <sub>19</sub> kkk	kkkk	kkkk <sub>8</sub>

1st word (k<7:0>)  
2nd word(k<19:8>)

Description:             Subroutine call of entire 2-Mbyte memory range. First, return address (PC+ 4) is pushed onto the return stack. If 's' = 1, the W, STATUS and BSR registers are also pushed into their respective shadow registers, WS, STATUSS and BSRS. If 's' = 0, no update occurs. Then, the 20-bit value 'k' is loaded into PC<20:1>. CALL is a 2-cycle instruction.

Words:                    2

Cycles:                    2

Q Cycle Activity:

Q1	Q2	Q3	Q4
Decode	Read literal 'k'<7:0>,	Push PC to stack	Read literal 'k'<19:8>, Write to PC
No operation	No operation	No operation	No operation

Example:                           HERE            CALL    THERE, 1

Before Instruction  
PC                    =    address (HERE)

After Instruction  
PC                    =    address (THERE)  
TOS                  =    address (HERE + 4)  
WS                    =    W  
BSRS                =    BSR  
STATUSS            =    STATUS

# PIC18F87J72

## CLRF Clear f

Syntax: CLRF f{,a}  
 Operands:  $0 \leq f \leq 255$   
 $a \in [0,1]$   
 Operation:  $000h \rightarrow f$ ,  
 $1 \rightarrow Z$   
 Status Affected: Z

Encoding:	0110	101a	ffff	ffff
-----------	------	------	------	------

Description: Clears the contents of the specified register.  
 If 'a' is '0', the Access Bank is selected.  
 If 'a' is '1', the BSR is used to select the GPR bank.  
 If 'a' is '0' and the extended instruction set is enabled, this instruction operates in Indexed Literal Offset Addressing mode whenever  $f \leq 95$  (5Fh). See [Section 27.2.3 "Byte-Oriented and Bit-Oriented Instructions in Indexed Literal Offset Mode"](#) for details.

Words: 1  
 Cycles: 1

Q Cycle Activity:

Q1	Q2	Q3	Q4
Decode	Read register 'f'	Process Data	Write register 'f'

**Example:** CLRF FLAG\_REG, 1

Before Instruction  
 FLAG\_REG = 5Ah  
 After Instruction  
 FLAG\_REG = 00h

## CLRWDTClear Watchdog Timer

Syntax: CLRWDTClear Watchdog Timer  
 Operands: None  
 Operation:  $000h \rightarrow$  WDT,  
 $000h \rightarrow$  WDT postscaler,  
 $1 \rightarrow \overline{TO}$ ,  
 $1 \rightarrow \overline{PD}$

Status Affected:  $\overline{TO}$ ,  $\overline{PD}$

Encoding:	0000	0000	0000	0100
-----------	------	------	------	------

Description: CLRWDTClear Watchdog Timer. It also resets the postscaler of the WDT. Status bits,  $\overline{TO}$  and  $\overline{PD}$ , are set.

Words: 1

Cycles: 1

Q Cycle Activity:

Q1	Q2	Q3	Q4
Decode	No operation	Process Data	No operation

**Example:** CLRWDTClear Watchdog Timer

Before Instruction  
 WDT Counter = ?  
 After Instruction  
 WDT Counter = 00h  
 WDT Postscaler = 0  
 $\overline{TO}$  = 1  
 $\overline{PD}$  = 1

**COMF**                      **Complement f**

---

Syntax:                      COMF f {,d {,a}}

Operands:                     $0 \leq f \leq 255$   
 $d \in [0,1]$   
 $a \in [0,1]$

Operation:                    $\bar{f} \rightarrow \text{dest}$

Status Affected:           N, Z

Encoding:                   

0001	11da	ffff	ffff
------	------	------	------

Description:                The contents of register 'f' are complemented. If 'd' is '0', the result is stored in W. If 'd' is '1', the result is stored back in register 'f'.  
  
 If 'a' is '0', the Access Bank is selected. If 'a' is '1', the BSR is used to select the GPR bank.  
  
 If 'a' is '0' and the extended instruction set is enabled, this instruction operates in Indexed Literal Offset Addressing mode whenever  $f \leq 95$  (5Fh). See [Section 27.2.3 "Byte-Oriented and Bit-Oriented Instructions in Indexed Literal Offset Mode"](#) for details.

Words:                        1

Cycles:                        1

Q Cycle Activity:

Q1	Q2	Q3	Q4
Decode	Read register 'f'	Process Data	Write to destination

**Example:**                    COMF                    REG, 0, 0

Before Instruction  
 REG = 13h  
 After Instruction  
 REG = 13h  
 W = ECh

**CPFSEQ**                    **Compare f with W, Skip if f = W**

---

Syntax:                      CPFSEQ f {,a}

Operands:                     $0 \leq f \leq 255$   
 $a \in [0,1]$

Operation:                     $(f) - (W)$ ,  
 skip if  $(f) = (W)$   
 (unsigned comparison)

Status Affected:            None

Encoding:                    

0110	001a	ffff	ffff
------	------	------	------

Description:                Compares the contents of data memory location 'f' to the contents of W by performing an unsigned subtraction.  
  
 If 'f' = W, then the fetched instruction is discarded and a NOP is executed instead, making this a 2-cycle instruction.  
  
 If 'a' is '0', the Access Bank is selected. If 'a' is '1', the BSR is used to select the GPR bank.  
  
 If 'a' is '0' and the extended instruction set is enabled, this instruction operates in Indexed Literal Offset Addressing mode whenever  $f \leq 95$  (5Fh). See [Section 27.2.3 "Byte-Oriented and Bit-Oriented Instructions in Indexed Literal Offset Mode"](#) for details.

Words:                        1

Cycles:                        1(2)  
**Note:** 3 cycles if skip and followed by a 2-word instruction.

Q Cycle Activity:

Q1	Q2	Q3	Q4
Decode	Read register 'f'	Process Data	No operation

If skip:

Q1	Q2	Q3	Q4
No operation	No operation	No operation	No operation

If skip and followed by 2-word instruction:

Q1	Q2	Q3	Q4
No operation	No operation	No operation	No operation
No operation	No operation	No operation	No operation

**Example:**                    HERE                    CPFSEQ REG, 0  
 NEQUAL                    :  
 EQUAL                     :

Before Instruction  
 PC Address = HERE  
 W = ?  
 REG = ?  
 After Instruction  
 If REG = W;  
     PC = Address (EQUAL)  
 If REG  $\neq$  W;  
     PC = Address (NEQUAL)

# PIC18F87J72

## CPFSGT Compare f with W, Skip if f > W

Syntax: CPFSGT f{,a}

Operands:  $0 \leq f \leq 255$   
 $a \in [0,1]$

Operation:  $(f) - (W)$ ,  
 skip if  $(f) > (W)$   
 (unsigned comparison)

Status Affected: None

Encoding: 

0110	010a	ffff	ffff
------	------	------	------

Description: Compares the contents of data memory location 'f' to the contents of the W by performing an unsigned subtraction.

If the contents of 'f' are greater than the contents of WREG, then the fetched instruction is discarded and a NOP is executed instead, making this a 2-cycle instruction.

If 'a' is '0', the Access Bank is selected. If 'a' is '1', the BSR is used to select the GPR bank.

If 'a' is '0' and the extended instruction set is enabled, this instruction operates in Indexed Literal Offset Addressing mode whenever  $f \leq 95$  (5Fh). See [Section 27.2.3 "Byte-Oriented and Bit-Oriented Instructions in Indexed Literal Offset Mode"](#) for details.

Words: 1

Cycles: 1(2)

**Note:** 3 cycles if skip and followed by a 2-word instruction.

Q Cycle Activity:

Q1	Q2	Q3	Q4
Decode	Read register 'f'	Process Data	No operation

If skip:

Q1	Q2	Q3	Q4
No operation	No operation	No operation	No operation

If skip and followed by 2-word instruction:

Q1	Q2	Q3	Q4
No operation	No operation	No operation	No operation
No operation	No operation	No operation	No operation

**Example:** HERE CPFSGT REG, 0  
 NGREATER :  
 GREATER :

Before Instruction  
 PC = Address (HERE)  
 W = ?

After Instruction  
 If REG > W;  
 PC = Address (GREATER)  
 If REG ≤ W;  
 PC = Address (NGREATER)

## CPFSLT Compare f with W, Skip if f < W

Syntax: CPFSLT f{,a}

Operands:  $0 \leq f \leq 255$   
 $a \in [0,1]$

Operation:  $(f) - (W)$ ,  
 skip if  $(f) < (W)$   
 (unsigned comparison)

Status Affected: None

Encoding: 

0110	000a	ffff	ffff
------	------	------	------

Description: Compares the contents of data memory location 'f' to the contents of W by performing an unsigned subtraction.

If the contents of 'f' are less than the contents of W, then the fetched instruction is discarded and a NOP is executed instead, making this a 2-cycle instruction.

If 'a' is '0', the Access Bank is selected. If 'a' is '1', the BSR is used to select the GPR bank.

Words: 1

Cycles: 1(2)

**Note:** 3 cycles if skip and followed by a 2-word instruction.

Q Cycle Activity:

Q1	Q2	Q3	Q4
Decode	Read register 'f'	Process Data	No operation

If skip:

Q1	Q2	Q3	Q4
No operation	No operation	No operation	No operation

If skip and followed by 2-word instruction:

Q1	Q2	Q3	Q4
No operation	No operation	No operation	No operation
No operation	No operation	No operation	No operation

**Example:** HERE CPFSLT REG, 1  
 NLESS :  
 LESS :

Before Instruction  
 PC = Address (HERE)  
 W = ?

After Instruction  
 If REG < W;  
 PC = Address (LESS)  
 If REG ≥ W;  
 PC = Address (NLESS)

DAW	Decimal Adjust W Register								
Syntax:	DAW								
Operands:	None								
Operation:	<p>If <math>[W&lt;3:0&gt; &gt; 9]</math> or <math>[DC = 1]</math>, then  <math>(W&lt;3:0&gt;) + 6 \rightarrow W&lt;3:0&gt;</math>;                      else  <math>(W&lt;3:0&gt;) \rightarrow W&lt;3:0&gt;</math></p> <p>If <math>[W&lt;7:4&gt; &gt; 9]</math> or <math>[C = 1]</math>, then  <math>(W&lt;7:4&gt;) + 6 \rightarrow W&lt;7:4&gt;</math>;  <math>C = 1</math>;                      else  <math>(W&lt;7:4&gt;) \rightarrow W&lt;7:4&gt;</math></p>								
Status Affected:	C								
Encoding:	<table border="1"> <tr> <td>0000</td> <td>0000</td> <td>0000</td> <td>0111</td> </tr> </table>	0000	0000	0000	0111				
0000	0000	0000	0111						
Description:	DAW adjusts the 8-bit value in W, resulting from the earlier addition of two variables (each in packed BCD format) and produces a correct packed BCD result.								
Words:	1								
Cycles:	1								
Q Cycle Activity:	<table border="1"> <thead> <tr> <th>Q1</th> <th>Q2</th> <th>Q3</th> <th>Q4</th> </tr> </thead> <tbody> <tr> <td>Decode</td> <td>Read register W</td> <td>Process Data</td> <td>Write W</td> </tr> </tbody> </table>	Q1	Q2	Q3	Q4	Decode	Read register W	Process Data	Write W
Q1	Q2	Q3	Q4						
Decode	Read register W	Process Data	Write W						

**Example 1:**            DAW

Before Instruction

W     =    A5h  
 C     =    0  
 DC    =    0

After Instruction

W     =    05h  
 C     =    1  
 DC    =    0

**Example 2:**

Before Instruction

W     =    CEh  
 C     =    0  
 DC    =    0

After Instruction

W     =    34h  
 C     =    1  
 DC    =    0

DECF	Decrement f								
Syntax:	DECF f{,d{,a}}								
Operands:	$0 \leq f \leq 255$ $d \in [0,1]$ $a \in [0,1]$								
Operation:	$(f) - 1 \rightarrow \text{dest}$								
Status Affected:	C, DC, N, OV, Z								
Encoding:	<table border="1"> <tr> <td>0000</td> <td>01da</td> <td>ffff</td> <td>ffff</td> </tr> </table>	0000	01da	ffff	ffff				
0000	01da	ffff	ffff						
Description:	<p>Decrement register 'f'. If 'd' is '0', the result is stored in W. If 'd' is '1', the result is stored back in register 'f'.</p> <p>If 'a' is '0', the Access Bank is selected. If 'a' is '1', the BSR is used to select the GPR bank.</p> <p>If 'a' is '0' and the extended instruction set is enabled, this instruction operates in Indexed Literal Offset Addressing mode whenever <math>f \leq 95</math> (5Fh). See <a href="#">Section 27.2.3 "Byte-Oriented and Bit-Oriented Instructions in Indexed Literal Offset Mode"</a> for details.</p>								
Words:	1								
Cycles:	1								
Q Cycle Activity:	<table border="1"> <thead> <tr> <th>Q1</th> <th>Q2</th> <th>Q3</th> <th>Q4</th> </tr> </thead> <tbody> <tr> <td>Decode</td> <td>Read register 'f'</td> <td>Process Data</td> <td>Write to destination</td> </tr> </tbody> </table>	Q1	Q2	Q3	Q4	Decode	Read register 'f'	Process Data	Write to destination
Q1	Q2	Q3	Q4						
Decode	Read register 'f'	Process Data	Write to destination						

**Example:**            DECF    CNT,    1,    0

Before Instruction

CNT   =    01h  
 Z     =    0

After Instruction

CNT   =    00h  
 Z     =    1

# PIC18F87J72

**DECFSZ**      **Decrement f, Skip if 0**

---

Syntax:      DECFSZ f {,d {,a}}

Operands:     $0 \leq f \leq 255$   
               $d \in [0,1]$   
               $a \in [0,1]$

Operation:     $(f) - 1 \rightarrow \text{dest}$ ,  
              skip if result = 0

Status Affected:    None

Encoding:     

0010	11da	ffff	ffff
------	------	------	------

Description:    The contents of register 'f' are decremented. If 'd' is '0', the result is placed in W. If 'd' is '1', the result is placed back in register 'f'.  
  
              If the result is '0', the next instruction which is already fetched is discarded and a NOP is executed instead, making it a 2-cycle instruction.  
  
              If 'a' is '0', the Access Bank is selected. If 'a' is '1', the BSR is used to select the GPR bank.  
  
              If 'a' is '0' and the extended instruction set is enabled, this instruction operates in Indexed Literal Offset Addressing mode whenever  $f \leq 95$  (5Fh). See [Section 27.2.3 "Byte-Oriented and Bit-Oriented Instructions in Indexed Literal Offset Mode"](#) for details.

Words:        1

Cycles:        1(2)  
              **Note:** 3 cycles if skip and followed by a 2-word instruction.

Q Cycle Activity:

Q1	Q2	Q3	Q4
Decode	Read register 'f'	Process Data	Write to destination

If skip:

Q1	Q2	Q3	Q4
No operation	No operation	No operation	No operation

If skip and followed by 2-word instruction:

Q1	Q2	Q3	Q4
No operation	No operation	No operation	No operation
No operation	No operation	No operation	No operation

**Example:**

```
HERE      DECFSZ    CNT, 1, 1
           GOTO      LOOP
CONTINUE
```

Before Instruction  
PC = Address (HERE)

After Instruction  
CNT = CNT - 1  
If CNT = 0;  
PC = Address (CONTINUE)  
If CNT  $\neq$  0;  
PC = Address (HERE + 2)

**DCFSNZ**      **Decrement f, Skip if Not 0**

---

Syntax:      DCFSNZ f {,d {,a}}

Operands:     $0 \leq f \leq 255$   
               $d \in [0,1]$   
               $a \in [0,1]$

Operation:     $(f) - 1 \rightarrow \text{dest}$ ,  
              skip if result  $\neq$  0

Status Affected:    None

Encoding:     

0100	11da	ffff	ffff
------	------	------	------

Description:    The contents of register 'f' are decremented. If 'd' is '0', the result is placed in W. If 'd' is '1', the result is placed back in register 'f'.  
  
              If the result is not '0', the next instruction which is already fetched is discarded and a NOP is executed instead, making it a 2-cycle instruction.  
  
              If 'a' is '0', the Access Bank is selected. If 'a' is '1', the BSR is used to select the GPR bank.  
  
              If 'a' is '0' and the extended instruction set is enabled, this instruction operates in Indexed Literal Offset Addressing mode whenever  $f \leq 95$  (5Fh). See [Section 27.2.3 "Byte-Oriented and Bit-Oriented Instructions in Indexed Literal Offset Mode"](#) for details.

Words:        1

Cycles:        1(2)  
              **Note:** 3 cycles if skip and followed by a 2-word instruction.

Q Cycle Activity:

Q1	Q2	Q3	Q4
Decode	Read register 'f'	Process Data	Write to destination

If skip:

Q1	Q2	Q3	Q4
No operation	No operation	No operation	No operation

If skip and followed by 2-word instruction:

Q1	Q2	Q3	Q4
No operation	No operation	No operation	No operation
No operation	No operation	No operation	No operation

**Example:**

```
HERE      DCFSNZ    TEMP, 1, 0
           :
NZERO     :
```

Before Instruction  
TEMP = ?

After Instruction  
TEMP = TEMP - 1,  
= 0;  
If TEMP = 0;  
PC = Address (ZERO)  
If TEMP  $\neq$  0;  
PC = Address (NZERO)

**GOTO**                      **Unconditional Branch**

---

Syntax:                      GOTO k

Operands:                     $0 \leq k \leq 1048575$

Operation:                    $k \rightarrow PC<20:1>$

Status Affected:           None

Encoding:

1st word (k<7:0>)	1110	1111	k <sub>7</sub> kkk	kkkk <sub>0</sub>
2nd word(k<19:8>)	1111	k <sub>19</sub> kkk	kkkk	kkkk <sub>8</sub>

Description:

GOTO allows an unconditional branch anywhere within entire 2-Mbyte memory range. The 20-bit value 'k' is loaded into PC<20:1>. GOTO is always a 2-cycle instruction.

Words:                      2

Cycles:                      2

Q Cycle Activity:

	Q1	Q2	Q3	Q4
Decode		Read literal 'k'<7:0>,	No operation	Read literal 'k'<19:8>, Write to PC
No operation	No operation	No operation	No operation	No operation

Example:                      GOTO THERE

After Instruction  
PC = Address (THERE)

**INCF**                      **Increment f**

---

Syntax:                      INCF f{,d{,a}}

Operands:                     $0 \leq f \leq 255$   
 $d \in [0,1]$   
 $a \in [0,1]$

Operation:                     $(f) + 1 \rightarrow \text{dest}$

Status Affected:            C, DC, N, OV, Z

Encoding:

0010	10da	ffff	ffff
------	------	------	------

Description:

The contents of register 'f' are incremented. If 'd' is '0', the result is placed in W. If 'd' is '1', the result is placed back in register 'f'.

If 'a' is '0', the Access Bank is selected. If 'a' is '1', the BSR is used to select the GPR bank.

If 'a' is '0' and the extended instruction set is enabled, this instruction operates in Indexed Literal Offset Addressing mode whenever  $f \leq 95$  (5Fh). See [Section 27.2.3 "Byte-Oriented and Bit-Oriented Instructions in Indexed Literal Offset Mode"](#) for details.

Words:                      1

Cycles:                      1

Q Cycle Activity:

	Q1	Q2	Q3	Q4
Decode		Read register 'f'	Process Data	Write to destination

Example:                      INCF     CNT, 1, 0

Before Instruction

CNT = FFh  
Z = 0  
C = ?  
DC = ?

After Instruction

CNT = 00h  
Z = 1  
C = 1  
DC = 1

# PIC18F87J72

**INCFSZ**                    **Increment f, Skip if 0**

Syntax:                    INCFSZ f {,d {,a}}

Operands:                 $0 \leq f \leq 255$   
 $d \in [0,1]$   
 $a \in [0,1]$

Operation:                 $(f) + 1 \rightarrow \text{dest}$ ,  
skip if result = 0

Status Affected:        None

Encoding:                

0011	11da	ffff	ffff
------	------	------	------

Description:             The contents of register 'f' are incremented. If 'd' is '0', the result is placed in W. If 'd' is '1', the result is placed back in register 'f'.  
  
If the result is '0', the next instruction which is already fetched is discarded and a NOP is executed instead, making it a 2-cycle instruction.  
  
If 'a' is '0', the Access Bank is selected. If 'a' is '1', the BSR is used to select the GPR bank.  
  
If 'a' is '0' and the extended instruction set is enabled, this instruction operates in Indexed Literal Offset Addressing mode whenever  $f \leq 95$  (5Fh). See [Section 27.2.3 "Byte-Oriented and Bit-Oriented Instructions in Indexed Literal Offset Mode"](#) for details.

Words:                    1

Cycles:                   1(2)  
**Note:** 3 cycles if skip and followed by a 2-word instruction.

Q Cycle Activity:

Q1	Q2	Q3	Q4
Decode	Read register 'f'	Process Data	Write to destination

If skip:

Q1	Q2	Q3	Q4
No operation	No operation	No operation	No operation

If skip and followed by 2-word instruction:

Q1	Q2	Q3	Q4
No operation	No operation	No operation	No operation
No operation	No operation	No operation	No operation

**Example:**                HERE    INCFSZ   CNT, 1, 0  
                              NZERO :  
                              ZERO  :

Before Instruction  
PC = Address (HERE)  
After Instruction  
CNT = CNT + 1  
If CNT = 0;  
PC = Address (ZERO)  
If CNT  $\neq$  0;  
PC = Address (NZERO)

**INFSNZ**                    **Increment f, Skip if Not 0**

Syntax:                    INFSNZ f {,d {,a}}

Operands:                 $0 \leq f \leq 255$   
 $d \in [0,1]$   
 $a \in [0,1]$

Operation:                 $(f) + 1 \rightarrow \text{dest}$ ,  
skip if result  $\neq$  0

Status Affected:        None

Encoding:                

0100	10da	ffff	ffff
------	------	------	------

Description:             The contents of register 'f' are incremented. If 'd' is '0', the result is placed in W. If 'd' is '1', the result is placed back in register 'f'.  
  
If the result is not '0', the next instruction which is already fetched is discarded and a NOP is executed instead, making it a 2-cycle instruction.  
  
If 'a' is '0', the Access Bank is selected. If 'a' is '1', the BSR is used to select the GPR bank.  
  
If 'a' is '0' and the extended instruction set is enabled, this instruction operates in Indexed Literal Offset Addressing mode whenever  $f \leq 95$  (5Fh). See [Section 27.2.3 "Byte-Oriented and Bit-Oriented Instructions in Indexed Literal Offset Mode"](#) for details.

Words:                    1

Cycles:                   1(2)  
**Note:** 3 cycles if skip and followed by a 2-word instruction.

Q Cycle Activity:

Q1	Q2	Q3	Q4
Decode	Read register 'f'	Process Data	Write to destination

If skip:

Q1	Q2	Q3	Q4
No operation	No operation	No operation	No operation

If skip and followed by 2-word instruction:

Q1	Q2	Q3	Q4
No operation	No operation	No operation	No operation
No operation	No operation	No operation	No operation

**Example:**                HERE    INFSNZ   REG, 1, 0  
                              ZERO  
                              NZERO

Before Instruction  
PC = Address (HERE)  
After Instruction  
REG = REG + 1  
If REG  $\neq$  0;  
PC = Address (NZERO)  
If REG = 0;  
PC = Address (ZERO)



**IORLW**                      **Inclusive OR Literal with W**

---

Syntax:                      IORLW k

Operands:                     $0 \leq k \leq 255$

Operation:                    (W) .OR. k  $\rightarrow$  W

Status Affected:            N, Z

Encoding:                    

0000	1001	kkkk	kkkk
------	------	------	------

Description:                The contents of W are ORed with the 8-bit literal 'k'. The result is placed in W.

Words:                        1

Cycles:                        1

Q Cycle Activity:

Q1	Q2	Q3	Q4
Decode	Read literal 'k'	Process Data	Write to W

Example:                    IORLW    35h

Before Instruction

W        =    9Ah

After Instruction

W        =    BFh

**IORWF**                      **Inclusive OR W with f**

---

Syntax:                      IORWF f {,d {,a}}

Operands:                     $0 \leq f \leq 255$   
 $d \in [0,1]$   
 $a \in [0,1]$

Operation:                    (W) .OR. (f)  $\rightarrow$  dest

Status Affected:            N, Z

Encoding:                    

0001	00da	ffff	ffff
------	------	------	------

Description:                Inclusive OR W with register 'f'. If 'd' is '0', the result is placed in W. If 'd' is '1', the result is placed back in register 'f'.  
  
If 'a' is '0', the Access Bank is selected. If 'a' is '1', the BSR is used to select the GPR bank.  
  
If 'a' is '0' and the extended instruction set is enabled, this instruction operates in Indexed Literal Offset Addressing mode whenever  $f \leq 95$  (5Fh). See [Section 27.2.3 "Byte-Oriented and Bit-Oriented Instructions in Indexed Literal Offset Mode"](#) for details.

Words:                        1

Cycles:                        1

Q Cycle Activity:

Q1	Q2	Q3	Q4
Decode	Read register 'f'	Process Data	Write to destination

Example:                    IORWF RESULT, 0, 1

Before Instruction

RESULT = 13h

W        = 91h

After Instruction

RESULT = 13h

W        = 93h

# PIC18F87J72

**LFSR**                      **Load FSR**

---

Syntax:                      LFSR f, k

Operands:                     $0 \leq f \leq 2$   
 $0 \leq k \leq 4095$

Operation:                     $k \rightarrow \text{FSRf}$

Status Affected:            None

Encoding:                    

1110	1110	00ff	$k_{11}kkk$
1111	0000	$k_7kkk$	kkkk

Description:                The 12-bit literal 'k' is loaded into the file select register pointed to by 'f'.

Words:                        2

Cycles:                        2

Q Cycle Activity:

Q1	Q2	Q3	Q4
Decode	Read literal 'k' MSB	Process Data	Write literal 'k' MSB to FSRfH
Decode	Read literal 'k' LSB	Process Data	Write literal 'k' to FSRfL

Example:                      LFSR 2, 3ABh

After Instruction

FSR2H                      = 03h  
 FSR2L                      = ABh

**MOVF**                      **Move f**

---

Syntax:                      MOVF f {,d {,a}}

Operands:                     $0 \leq f \leq 255$   
 $d \in [0,1]$   
 $a \in [0,1]$

Operation:                     $f \rightarrow \text{dest}$

Status Affected:            N, Z

Encoding:                    

0101	00da	ffff	ffff
------	------	------	------

Description:                The contents of register 'f' are moved to a destination dependent upon the status of 'd'. If 'd' is '0', the result is placed in W. If 'd' is '1', the result is placed back in register 'f'. Location 'f' can be anywhere in the 256-byte bank.

If 'a' is '0', the Access Bank is selected. If 'a' is '1', the BSR is used to select the GPR bank.

If 'a' is '0' and the extended instruction set is enabled, this instruction operates in Indexed Literal Offset Addressing mode whenever  $f \leq 95$  (5Fh). See [Section 27.2.3 "Byte-Oriented and Bit-Oriented Instructions in Indexed Literal Offset Mode"](#) for details.

Words:                        1

Cycles:                        1

Q Cycle Activity:

Q1	Q2	Q3	Q4
Decode	Read register 'f'	Process Data	Write W

Example:                      MOVF REG, 0, 0

Before Instruction

REG                        = 22h  
 W                            = FFh

After Instruction

REG                        = 22h  
 W                            = 22h

**MOVFF**                      **Move f to f**

---

Syntax:                      MOVFF  $f_s, f_d$

Operands:                     $0 \leq f_s \leq 4095$   
 $0 \leq f_d \leq 4095$

Operation:                     $(f_s) \rightarrow f_d$

Status Affected:            None

Encoding:

1100	ffff	ffff	ffff <sub>s</sub>
1111	ffff	ffff	ffff <sub>d</sub>

1st word (source)

2nd word (destin.)

Description:

The contents of source register 'f<sub>s</sub>' are moved to destination register 'f<sub>d</sub>'. Location of source 'f<sub>s</sub>' can be anywhere in the 4096-byte data space (000h to FFFh) and location of destination 'f<sub>d</sub>' can also be anywhere from 000h to FFFh.

Either source or destination can be W (a useful special situation).

MOVFF is particularly useful for transferring a data memory location to a peripheral register (such as the transmit buffer or an I/O port).

The MOVFF instruction cannot use the PCL, TOSU, TOSH or TOSL as the destination register

Words:                      2

Cycles:                      2

Q Cycle Activity:

Q1	Q2	Q3	Q4
Decode	Read register 'f' (src)	Process Data	No operation
Decode	No operation No dummy read	No operation	Write register 'f' (dest)

Example:                      MOVFF    REG1, REG2

Before Instruction

REG1                      =    33h  
 REG2                      =    11h

After Instruction

REG1                      =    33h  
 REG2                      =    33h

**MOVLB**                      **Move Literal to Low Nibble in BSR**

---

Syntax:                      MOVLW k

Operands:                     $0 \leq k \leq 255$

Operation:                     $k \rightarrow \text{BSR}$

Status Affected:            None

Encoding:

0000	0001	kkkk	kkkk
------	------	------	------

Description:

The 8-bit literal 'k' is loaded into the Bank Select Register (BSR). The value of BSR<7:4> always remains '0' regardless of the value of k<sub>7:k<sub>4</sub></sub>.

Words:                      1

Cycles:                      1

Q Cycle Activity:

Q1	Q2	Q3	Q4
Decode	Read literal 'k'	Process Data	Write literal 'k' to BSR

Example:                      MOVLB    5

Before Instruction

BSR Register =    02h

After Instruction

BSR Register =    05h

# PIC18F87J72

## MOVLW Move Literal to W

Syntax: MOVLW k

Operands:  $0 \leq k \leq 255$

Operation:  $k \rightarrow W$

Status Affected: None

Encoding: 

0000	1110	kkkk	kkkk
------	------	------	------

Description: The 8-bit literal 'k' is loaded into W.

Words: 1

Cycles: 1

Q Cycle Activity:

Q1	Q2	Q3	Q4
Decode	Read literal 'k'	Process Data	Write to W

Example: MOVLW 5Ah

After Instruction  
W = 5Ah

## MOVWF Move W to f

Syntax: MOVWF f{,a}

Operands:  $0 \leq f \leq 255$   
 $a \in [0,1]$

Operation:  $(W) \rightarrow f$

Status Affected: None

Encoding: 

0110	111a	ffff	ffff
------	------	------	------

Description: Move data from W to register 'f'.  
Location 'f' can be anywhere in the 256-byte bank.

If 'a' is '0', the Access Bank is selected.  
If 'a' is '1', the BSR is used to select the GPR bank.

If 'a' is '0' and the extended instruction set is enabled, this instruction operates in Indexed Literal Offset Addressing mode whenever  $f \leq 95$  (5Fh). See [Section 27.2.3 "Byte-Oriented and Bit-Oriented Instructions in Indexed Literal Offset Mode"](#) for details.

Words: 1

Cycles: 1

Q Cycle Activity:

Q1	Q2	Q3	Q4
Decode	Read register 'f'	Process Data	Write register 'f'

Example: MOVWF REG, 0

Before Instruction

W = 4Fh  
REG = FFh

After Instruction

W = 4Fh  
REG = 4Fh

**MULLW**      **Multiply Literal with W**

---

Syntax:            MULLW k

Operands:         $0 \leq k \leq 255$

Operation:         $(W) \times k \rightarrow \text{PRODH:PRODL}$

Status Affected:    None

Encoding:        

0000	1101	kkkk	kkkk
------	------	------	------

Description:      An unsigned multiplication is carried out between the contents of W and the 8-bit literal 'k'. The 16-bit result is placed in the PRODH:PRODL register pair. PRODH contains the high byte. W is unchanged.

                    None of the Status flags are affected.

                    Note that neither Overflow nor Carry is possible in this operation. A Zero result is possible but not detected.

Words:            1

Cycles:            1

Q Cycle Activity:

Q1	Q2	Q3	Q4
Decode	Read literal 'k'	Process Data	Write registers PRODH: PRODL

Example:            MULLW 0C4h

Before Instruction	
W	= E2h
PRODH	= ?
PRODL	= ?
After Instruction	
W	= E2h
PRODH	= ADh
PRODL	= 08h

**MULWF**      **Multiply W with f**

---

Syntax:            MULWF f{,a}

Operands:         $0 \leq f \leq 255$   
 $a \in [0,1]$

Operation:         $(W) \times (f) \rightarrow \text{PRODH:PRODL}$

Status Affected:    None

Encoding:        

0000	001a	ffff	ffff
------	------	------	------

Description:      An unsigned multiplication is carried out between the contents of W and the register file location 'f'. The 16-bit result is stored in the PRODH:PRODL register pair. PRODH contains the high byte. Both W and 'f' are unchanged.

                    None of the Status flags are affected.

                    Note that neither Overflow nor Carry is possible in this operation. A Zero result is possible but not detected.

                    If 'a' is '0', the Access Bank is selected. If 'a' is '1', the BSR is used to select the GPR bank.

                    If 'a' is '0' and the extended instruction set is enabled, this instruction operates in Indexed Literal Offset Addressing mode whenever  $f \leq 95$  (5Fh). See [Section 27.2.3 "Byte-Oriented and Bit-Oriented Instructions in Indexed Literal Offset Mode"](#) for details.

Words:            1

Cycles:            1

Q Cycle Activity:

Q1	Q2	Q3	Q4
Decode	Read register 'f'	Process Data	Write registers PRODH: PRODL

Example:            MULWF REG, 1

Before Instruction	
W	= C4h
REG	= B5h
PRODH	= ?
PRODL	= ?
After Instruction	
W	= C4h
REG	= B5h
PRODH	= 8Ah
PRODL	= 94h

# PIC18F87J72

**NEGF**                      **Negate f**

---

Syntax:                    `NEGF f{,a}`

Operands:                 $0 \leq f \leq 255$   
 $a \in [0,1]$

Operation:                 $(\bar{f}) + 1 \rightarrow f$

Status Affected:        `N, OV, C, DC, Z`

Encoding:                

0110	110a	ffff	ffff
------	------	------	------

Description:             Location 'f' is negated using two's complement. The result is placed in the data memory location 'f'.  
  
If 'a' is '0', the Access Bank is selected. If 'a' is '1', the BSR is used to select the GPR bank.  
  
If 'a' is '0' and the extended instruction set is enabled, this instruction operates in Indexed Literal Offset Addressing mode whenever  $f \leq 95$  (5Fh). See [Section 27.2.3 "Byte-Oriented and Bit-Oriented Instructions in Indexed Literal Offset Mode"](#) for details.

Words:                    1

Cycles:                    1

Q Cycle Activity:

Q1	Q2	Q3	Q4
Decode	Read register 'f'	Process Data	Write register 'f'

Example:                `NEGF REG, 1`

Before Instruction  
REG = 0011 1010 [3Ah]

After Instruction  
REG = 1100 0110 [C6h]

**NOP**                        **No Operation**

---

Syntax:                    `NOP`

Operands:                None

Operation:                No operation

Status Affected:        None

Encoding:                

0000	0000	0000	0000
1111	xxxx	xxxx	xxxx

Description:             No operation.

Words:                    1

Cycles:                    1

Q Cycle Activity:

Q1	Q2	Q3	Q4
Decode	No operation	No operation	No operation

Example:  
None.

POP	Pop Top of Return Stack								
Syntax:	POP								
Operands:	None								
Operation:	(TOS) → bit bucket								
Status Affected:	None								
Encoding:	<table border="1"> <tr> <td>0000</td> <td>0000</td> <td>0000</td> <td>0110</td> </tr> </table>	0000	0000	0000	0110				
0000	0000	0000	0110						
Description:	<p>The TOS value is pulled off the return stack and is discarded. The TOS value then becomes the previous value that was pushed onto the return stack.</p> <p>This instruction is provided to enable the user to properly manage the return stack to incorporate a software stack.</p>								
Words:	1								
Cycles:	1								
Q Cycle Activity:	<table border="1"> <thead> <tr> <th>Q1</th> <th>Q2</th> <th>Q3</th> <th>Q4</th> </tr> </thead> <tbody> <tr> <td>Decode</td> <td>No operation</td> <td>POP TOS value</td> <td>No operation</td> </tr> </tbody> </table>	Q1	Q2	Q3	Q4	Decode	No operation	POP TOS value	No operation
Q1	Q2	Q3	Q4						
Decode	No operation	POP TOS value	No operation						

**Example:**

	POP		NEW
	GOTO		
Before Instruction			
TOS	=	0031A2h	
Stack (1 level down)	=	014332h	
After Instruction			
TOS	=	014332h	
PC	=	NEW	

PUSH	Push Top of Return Stack								
Syntax:	PUSH								
Operands:	None								
Operation:	(PC + 2) → TOS								
Status Affected:	None								
Encoding:	<table border="1"> <tr> <td>0000</td> <td>0000</td> <td>0000</td> <td>0101</td> </tr> </table>	0000	0000	0000	0101				
0000	0000	0000	0101						
Description:	<p>The PC + 2 is pushed onto the top of the return stack. The previous TOS value is pushed down on the stack. This instruction allows implementing a software stack by modifying TOS and then pushing it onto the return stack.</p>								
Words:	1								
Cycles:	1								
Q Cycle Activity:	<table border="1"> <thead> <tr> <th>Q1</th> <th>Q2</th> <th>Q3</th> <th>Q4</th> </tr> </thead> <tbody> <tr> <td>Decode</td> <td>PUSH PC + 2 onto return stack</td> <td>No operation</td> <td>No operation</td> </tr> </tbody> </table>	Q1	Q2	Q3	Q4	Decode	PUSH PC + 2 onto return stack	No operation	No operation
Q1	Q2	Q3	Q4						
Decode	PUSH PC + 2 onto return stack	No operation	No operation						

**Example:**

	PUSH		
Before Instruction			
TOS	=	345Ah	
PC	=	0124h	
After Instruction			
PC	=	0126h	
TOS	=	0126h	
Stack (1 level down)	=	345Ah	

# PIC18F87J72

## RCALL Relative Call

Syntax: RCALL n

Operands:  $-1024 \leq n \leq 1023$

Operation: (PC) + 2 → TOS,  
(PC) + 2 + 2n → PC

Status Affected: None

Encoding: 

1101	1nnn	nnnn	nnnn
------	------	------	------

Description: Subroutine call with a jump up to 1K from the current location. First, return address (PC + 2) is pushed onto the stack. Then, add the 2's complement number '2n' to the PC. Since the PC will have incremented to fetch the next instruction, the new address will be PC + 2 + 2n. This instruction is a 2-cycle instruction.

Words: 1

Cycles: 2

Q Cycle Activity:

Q1	Q2	Q3	Q4
Decode	Read literal 'n' PUSH PC to stack	Process Data	Write to PC
No operation	No operation	No operation	No operation

Example:            HERE        RCALL Jump

Before Instruction

PC = Address (HERE)

After Instruction

PC = Address (Jump)

TOS = Address (HERE + 2)

## RESET Reset

Syntax: RESET

Operands: None

Operation: Reset all registers and flags that are affected by a MCLR Reset.

Status Affected: All

Encoding: 

0000	0000	1111	1111
------	------	------	------

Description: This instruction provides a way to execute a MCLR Reset in software.

Words: 1

Cycles: 1

Q Cycle Activity:

Q1	Q2	Q3	Q4
Decode	Start reset	No operation	No operation

Example:            RESET

After Instruction

Registers = Reset Value

Flags\* = Reset Value



**RETFIE**                    **Return from Interrupt**

---

Syntax:                    RETFIE {s}

Operands:                 $s \in [0,1]$

Operation:                (TOS) → PC,  
                               1 → GIE/GIEH or PEIE/GIEL;  
                               if  $s = 1$ ,  
                               (WS) → W,  
                               (STATUS) → STATUS,  
                               (BSRS) → BSR,  
                               PCLATU, PCLATH are unchanged

Status Affected:        GIE/GIEH, PEIE/GIEL.

Encoding:                

0000	0000	0001	000s
------	------	------	------

Description:             Return from interrupt. Stack is popped and Top-of-Stack (TOS) is loaded into the PC. Interrupts are enabled by setting either the high or low-priority global interrupt enable bit. If 's' = 1, the contents of the shadow registers WS, STATUS and BSRs are loaded into their corresponding registers W, STATUS and BSR. If 's' = 0, no update of these registers occurs.

Words:                    1

Cycles:                    2

Q Cycle Activity:

Q1	Q2	Q3	Q4
Decode	No operation	No operation	POP PC from stack Set GIEH or GIEL
No operation	No operation	No operation	No operation

Example:                RETFIE 1

After Interrupt

PC	=	TOS
W	=	WS
BSR	=	BSRS
STATUS	=	STATUS
GIE/GIEH, PEIE/GIEL	=	1

**RETLW**                    **Return Literal to W**

---

Syntax:                    RETLW k

Operands:                 $0 \leq k \leq 255$

Operation:                 $k \rightarrow W$ ,  
                               (TOS) → PC,  
                               PCLATU, PCLATH are unchanged

Status Affected:        None

Encoding:                

0000	1100	kkkk	kkkk
------	------	------	------

Description:             W is loaded with the 8-bit literal 'k'. The program counter is loaded from the top of the stack (the return address). The high address latch (PCLATH) remains unchanged.

Words:                    1

Cycles:                    2

Q Cycle Activity:

Q1	Q2	Q3	Q4
Decode	Read literal 'k'	Process Data	POP PC from stack, write to W
No operation	No operation	No operation	No operation

Example:

```
CALL TABLE ; W contains table
              ; offset value
              ; W now has
              ; table value
:
TABLE
  ADDWF PCL ; W = offset
  RETLW k0  ; Begin table
  RETLW k1  ;
:
  RETLW kn  ; End of table
```

Before Instruction  
 W = 07h

After Instruction  
 W = value of kn

# PIC18F87J72

## RETURN Return from Subroutine

**Syntax:** RETURN {s}

**Operands:** s ∈ [0,1]

**Operation:** (TOS) → PC;  
if s = 1,  
(WS) → W,  
(STATUS) → STATUS,  
(BSRS) → BSR,  
PCLATU, PCLATH are unchanged

**Status Affected:** None

**Encoding:**

0000	0000	0001	001s
------	------	------	------

**Description:** Return from subroutine. The stack is popped and the top of the stack (TOS) is loaded into the program counter. If 's' = 1, the contents of the shadow registers WS, STATUS and BSR are loaded into their corresponding registers W, STATUS and BSR. If 's' = 0, no update of these registers occurs.

**Words:** 1

**Cycles:** 2

**Q Cycle Activity:**

Q1	Q2	Q3	Q4
Decode	No operation	Process Data	POP PC from stack
No operation	No operation	No operation	No operation

**Example:** RETURN

After Instruction:  
PC = TOS

## RLCF Rotate Left f through Carry

**Syntax:** RLCF f {,d {,a}}

**Operands:** 0 ≤ f ≤ 255  
d ∈ [0,1]  
a ∈ [0,1]

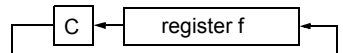
**Operation:** (f<n>) → dest<n + 1>,  
(f<7>) → C,  
(C) → dest<0>

**Status Affected:** C, N, Z

**Encoding:**

0011	01da	ffff	ffff
------	------	------	------

**Description:** The contents of register 'f' are rotated one bit to the left through the Carry flag. If 'd' is '0', the result is placed in W. If 'd' is '1', the result is stored back in register 'f'.  
  
If 'a' is '0', the Access Bank is selected. If 'a' is '1', the BSR is used to select the GPR bank.  
  
If 'a' is '0' and the extended instruction set is enabled, this instruction operates in Indexed Literal Offset Addressing mode whenever f ≤ 95 (5Fh). See [Section 27.2.3 "Byte-Oriented and Bit-Oriented Instructions in Indexed Literal Offset Mode"](#) for details.



**Words:** 1

**Cycles:** 1

**Q Cycle Activity:**

Q1	Q2	Q3	Q4
Decode	Read register 'f'	Process Data	Write to destination

**Example:** RLCF REG, 0, 0

Before Instruction  
REG = 1110 0110  
C = 0

After Instruction  
REG = 1110 0110  
W = 1100 1100  
C = 1

**RLNCF**      **Rotate Left f (No Carry)**

---

Syntax:            RLNCF    f {,d {,a}}

Operands:         $0 \leq f \leq 255$   
 $d \in [0,1]$   
 $a \in [0,1]$

Operation:        (f<n>) → dest<n + 1>,  
(f<7>) → dest<0>

Status Affected:    N, Z

Encoding:        

0100	01da	ffff	ffff
------	------	------	------

Description:      The contents of register 'f' are rotated one bit to the left. If 'd' is '0', the result is placed in W. If 'd' is '1', the result is stored back in register 'f'.  
  
If 'a' is '0', the Access Bank is selected. If 'a' is '1', the BSR is used to select the GPR bank.  
  
If 'a' is '0' and the extended instruction set is enabled, this instruction operates in Indexed Literal Offset Addressing mode whenever  $f \leq 95$  (5Fh). See [Section 27.2.3 "Byte-Oriented and Bit-Oriented Instructions in Indexed Literal Offset Mode"](#) for details.

Words:            1

Cycles:           1

Q Cycle Activity:

Q1	Q2	Q3	Q4
Decode	Read register 'f'	Process Data	Write to destination

**Example:**            RLNCF            REG, 1, 0

Before Instruction  
REG = 1010 1011  
After Instruction  
REG = 0101 0111

**RRCF**            **Rotate Right f through Carry**

---

Syntax:            RRCF    f {,d {,a}}

Operands:         $0 \leq f \leq 255$   
 $d \in [0,1]$   
 $a \in [0,1]$

Operation:        (f<n>) → dest<n - 1>,  
(f<0>) → C,  
(C) → dest<7>

Status Affected:    C, N, Z

Encoding:        

0011	00da	ffff	ffff
------	------	------	------

Description:      The contents of register 'f' are rotated one bit to the right through the Carry flag. If 'd' is '0', the result is placed in W. If 'd' is '1', the result is placed back in register 'f'.  
  
If 'a' is '0', the Access Bank is selected. If 'a' is '1', the BSR is used to select the GPR bank.  
  
If 'a' is '0' and the extended instruction set is enabled, this instruction operates in Indexed Literal Offset Addressing mode whenever  $f \leq 95$  (5Fh). See [Section 27.2.3 "Byte-Oriented and Bit-Oriented Instructions in Indexed Literal Offset Mode"](#) for details.

Words:            1

Cycles:           1

Q Cycle Activity:

Q1	Q2	Q3	Q4
Decode	Read register 'f'	Process Data	Write to destination

**Example:**            RRCF            REG, 0, 0

Before Instruction  
REG = 1110 0110  
C = 0  
After Instruction  
REG = 1110 0110  
W = 0111 0011  
C = 0

# PIC18F87J72

## RRNCF Rotate Right f (No Carry)

Syntax: RRNCF f {,d {,a}}

Operands:  $0 \leq f \leq 255$   
 $d \in [0,1]$   
 $a \in [0,1]$

Operation:  $(f < n) \rightarrow \text{dest} < n - 1 >$ ,  
 $(f < 0) \rightarrow \text{dest} < 7 >$

Status Affected: N, Z

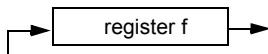
Encoding: 

0100	00da	ffff	ffff
------	------	------	------

Description: The contents of register 'f' are rotated one bit to the right. If 'd' is '0', the result is placed in W. If 'd' is '1', the result is placed back in register 'f'.

If 'a' is '0', the Access Bank will be selected, overriding the BSR value. If 'a' is '1', then the bank will be selected as per the BSR value.

If 'a' is '0' and the extended instruction set is enabled, this instruction operates in Indexed Literal Offset Addressing mode whenever  $f \leq 95$  (5Fh). See [Section 27.2.3 "Byte-Oriented and Bit-Oriented Instructions in Indexed Literal Offset Mode"](#) for details.



Words: 1

Cycles: 1

Q Cycle Activity:

Q1	Q2	Q3	Q4
Decode	Read register 'f'	Process Data	Write to destination

**Example 1:** RRNCF REG, 1, 0

Before Instruction  
 REG = 1101 0111  
 After Instruction  
 REG = 1110 1011

**Example 2:** RRNCF REG, 0, 0

Before Instruction  
 W = ?  
 REG = 1101 0111  
 After Instruction  
 W = 1110 1011  
 REG = 1101 0111

## SETF Set f

Syntax: SETF f {,a}

Operands:  $0 \leq f \leq 255$   
 $a \in [0,1]$

Operation: FFh  $\rightarrow$  f

Status Affected: None

Encoding: 

0110	100a	ffff	ffff
------	------	------	------

Description: The contents of the specified register are set to FFh.

If 'a' is '0', the Access Bank is selected. If 'a' is '1', the BSR is used to select the GPR bank.

If 'a' is '0' and the extended instruction set is enabled, this instruction operates in Indexed Literal Offset Addressing mode whenever  $f \leq 95$  (5Fh). See [Section 27.2.3 "Byte-Oriented and Bit-Oriented Instructions in Indexed Literal Offset Mode"](#) for details.

Words: 1

Cycles: 1

Q Cycle Activity:

Q1	Q2	Q3	Q4
Decode	Read register 'f'	Process Data	Write register 'f'

**Example:** SETF REG, 1

Before Instruction  
 REG = 5Ah  
 After Instruction  
 REG = FFh

SLEEP	Enter Sleep Mode								
Syntax:	SLEEP								
Operands:	None								
Operation:	00h → WDT, 0 → WDT postscaler, 1 → $\overline{TO}$ , 0 → $\overline{PD}$								
Status Affected:	$\overline{TO}$ , $\overline{PD}$								
Encoding:	<table border="1" style="display: inline-table;"><tr><td>0000</td><td>0000</td><td>0000</td><td>0011</td></tr></table>	0000	0000	0000	0011				
0000	0000	0000	0011						
Description:	The Power-Down Status bit ( $\overline{PD}$ ) is cleared. The Time-out Status bit ( $\overline{TO}$ ) is set. The Watchdog Timer and its postscaler are cleared.  The processor is put into Sleep mode with the oscillator stopped.								
Words:	1								
Cycles:	1								
Q Cycle Activity:	<table border="1" style="display: inline-table;"><thead><tr><th>Q1</th><th>Q2</th><th>Q3</th><th>Q4</th></tr></thead><tbody><tr><td>Decode</td><td>No operation</td><td>Process Data</td><td>Go to Sleep</td></tr></tbody></table>	Q1	Q2	Q3	Q4	Decode	No operation	Process Data	Go to Sleep
Q1	Q2	Q3	Q4						
Decode	No operation	Process Data	Go to Sleep						

**Example:** SLEEP

Before Instruction

$\overline{TO}$  = ?

$\overline{PD}$  = ?

After Instruction

$\overline{TO}$  = 1 †

$\overline{PD}$  = 0

† If WDT causes wake-up, this bit is cleared.

SUBFWB	Subtract f from W with Borrow								
Syntax:	SUBFWB f {,d {,a}}								
Operands:	$0 \leq f \leq 255$ $d \in [0,1]$ $a \in [0,1]$								
Operation:	$(W) - (f) - (\overline{C}) \rightarrow \text{dest}$								
Status Affected:	N, OV, C, DC, Z								
Encoding:	<table border="1" style="display: inline-table;"><tr><td>0101</td><td>01da</td><td>ffff</td><td>ffff</td></tr></table>	0101	01da	ffff	ffff				
0101	01da	ffff	ffff						
Description:	Subtract register 'f' and Carry flag (borrow) from W (2's complement method). If 'd' is '0', the result is stored in W. If 'd' is '1', the result is stored in register 'f'.  If 'a' is '0', the Access Bank is selected. If 'a' is '1', the BSR is used to select the GPR bank.  If 'a' is '0' and the extended instruction set is enabled, this instruction operates in Indexed Literal Offset Addressing mode whenever $f \leq 95$ (5Fh). See <a href="#">Section 27.2.3 "Byte-Oriented and Bit-Oriented Instructions in Indexed Literal Offset Mode"</a> for details.								
Words:	1								
Cycles:	1								
Q Cycle Activity:	<table border="1" style="display: inline-table;"><thead><tr><th>Q1</th><th>Q2</th><th>Q3</th><th>Q4</th></tr></thead><tbody><tr><td>Decode</td><td>Read register 'f'</td><td>Process Data</td><td>Write to destination</td></tr></tbody></table>	Q1	Q2	Q3	Q4	Decode	Read register 'f'	Process Data	Write to destination
Q1	Q2	Q3	Q4						
Decode	Read register 'f'	Process Data	Write to destination						

Words: 1

Cycles: 1

Q Cycle Activity:

Q1	Q2	Q3	Q4
Decode	Read register 'f'	Process Data	Write to destination

**Example 1:** SUBFWB REG, 1, 0

Before Instruction

REG = 3

W = 2

C = 1

After Instruction

REG = FF

W = 2

C = 0

Z = 0

N = 1 ; result is negative

**Example 2:** SUBFWB REG, 0, 0

Before Instruction

REG = 2

W = 5

C = 1

After Instruction

REG = 2

W = 3

C = 1

Z = 0

N = 0 ; result is positive

**Example 3:** SUBFWB REG, 1, 0

Before Instruction

REG = 1

W = 2

C = 0

After Instruction

REG = 0

W = 2

C = 1

Z = 1 ; result is zero

N = 0

# PIC18F87J72

**SUBLW**                      **Subtract W from Literal**

---

Syntax:                      SUBLW k

Operands:                     $0 \leq k \leq 255$

Operation:                    $k - (W) \rightarrow W$

Status Affected:            N, OV, C, DC, Z

Encoding:                    

0000	1000	kkkk	kkkk
------	------	------	------

Description:                W is subtracted from the 8-bit literal 'k'. The result is placed in W.

Words:                        1

Cycles:                        1

Q Cycle Activity:

Q1	Q2	Q3	Q4
Decode	Read literal 'k'	Process Data	Write to W

Example 1:                      SUBLW 02h

Before Instruction  
W = 01h  
C = ?

After Instruction  
W = 01h  
C = 1 ; result is positive  
Z = 0  
N = 0

Example 2:                      SUBLW 02h

Before Instruction  
W = 02h  
C = ?

After Instruction  
W = 00h  
C = 1 ; result is zero  
Z = 1  
N = 0

Example 3:                      SUBLW 02h

Before Instruction  
W = 03h  
C = ?

After Instruction  
W = FFh ; (2's complement)  
C = 0 ; result is negative  
Z = 0  
N = 1

**SUBWF**                      **Subtract W from f**

---

Syntax:                      SUBWF f{,d{,a}}

Operands:                     $0 \leq f \leq 255$   
 $d \in [0,1]$   
 $a \in [0,1]$

Operation:                     $(f) - (W) \rightarrow \text{dest}$

Status Affected:            N, OV, C, DC, Z

Encoding:                    

0101	11da	ffff	ffff
------	------	------	------

Description:                Subtract W from register 'f' (2's complement method). If 'd' is '0', the result is stored in W. If 'd' is '1', the result is stored back in register 'f'.

If 'a' is '0', the Access Bank is selected. If 'a' is '1', the BSR is used to select the GPR bank.

If 'a' is '0' and the extended instruction set is enabled, this instruction operates in Indexed Literal Offset Addressing mode whenever  $f \leq 95$  (5Fh). See [Section 27.2.3 "Byte-Oriented and Bit-Oriented Instructions in Indexed Literal Offset Mode"](#) for details.

Words:                        1

Cycles:                        1

Q Cycle Activity:

Q1	Q2	Q3	Q4
Decode	Read register 'f'	Process Data	Write to destination

Example 1:                      SUBWF REG, 1, 0

Before Instruction  
REG = 3  
W = 2  
C = ?

After Instruction  
REG = 1  
W = 2  
C = 1 ; result is positive  
Z = 0  
N = 0

Example 2:                      SUBWF REG, 0, 0

Before Instruction  
REG = 2  
W = 2  
C = ?

After Instruction  
REG = 2  
W = 0  
C = 1 ; result is zero  
Z = 1  
N = 0

Example 3:                      SUBWF REG, 1, 0

Before Instruction  
REG = 1  
W = 2  
C = ?

After Instruction  
REG = FFh ; (2's complement)  
W = 2  
C = 0 ; result is negative  
Z = 0  
N = 1

**SUBWFB**      **Subtract W from f with Borrow**

---

Syntax:            SUBWFB f{,d{,a}}

Operands:         $0 \leq f \leq 255$   
 $d \in [0,1]$   
 $a \in [0,1]$

Operation:         $(f) - (W) - (\overline{C}) \rightarrow \text{dest}$

Status Affected: N, OV, C, DC, Z

Encoding:        

0101	10da	ffff	ffff
------	------	------	------

Description:     Subtract W and the Carry flag (borrow) from register 'f' (2's complement method). If 'd' is '0', the result is stored in W. If 'd' is '1', the result is stored back in register 'f'.

                    If 'a' is '0', the Access Bank is selected. If 'a' is '1', the BSR is used to select the GPR bank.

                    If 'a' is '0' and the extended instruction set is enabled, this instruction operates in Indexed Literal Offset Addressing mode whenever  $f \leq 95$  (5Fh). See [Section 27.2.3 "Byte-Oriented and Bit-Oriented Instructions in Indexed Literal Offset Mode"](#) for details.

Words:            1

Cycles:           1

Q Cycle Activity:

	Q1	Q2	Q3	Q4
Decode				
Read register 'f'				
Process Data				
Write to destination				

**Example 1:**            SUBWFB REG, 1, 0

Before Instruction

REG = 19h      (0001 1001)

W = 0Dh      (0000 1101)

C = 1

After Instruction

REG = 0Ch      (0000 1011)

W = 0Dh      (0000 1101)

C = 1

Z = 0

N = 0            ; result is positive

**Example 2:**            SUBWFB REG, 0, 0

Before Instruction

REG = 1Bh      (0001 1011)

W = 1Ah      (0001 1010)

C = 0

After Instruction

REG = 1Bh      (0001 1011)

W = 00h

C = 1

Z = 1            ; result is zero

N = 0

**Example 3:**            SUBWFB REG, 1, 0

Before Instruction

REG = 03h      (0000 0011)

W = 0Eh      (0000 1101)

C = 1

After Instruction

REG = F5h      (1111 0100)  
                    ; [2's comp]

W = 0Eh      (0000 1101)

C = 0

Z = 0

N = 1            ; result is negative

**SWAPF**        **Swap f**

---

Syntax:            SWAPF f{,d{,a}}

Operands:         $0 \leq f \leq 255$   
 $d \in [0,1]$   
 $a \in [0,1]$

Operation:         $(f<3:0>) \rightarrow \text{dest}<7:4>$ ,  
 $(f<7:4>) \rightarrow \text{dest}<3:0>$

Status Affected: None

Encoding:        

0011	10da	ffff	ffff
------	------	------	------

Description:     The upper and lower nibbles of register 'f' are exchanged. If 'd' is '0', the result is placed in W. If 'd' is '1', the result is placed in register 'f'.

                    If 'a' is '0', the Access Bank is selected. If 'a' is '1', the BSR is used to select the GPR bank.

                    If 'a' is '0' and the extended instruction set is enabled, this instruction operates in Indexed Literal Offset Addressing mode whenever  $f \leq 95$  (5Fh). See [Section 27.2.3 "Byte-Oriented and Bit-Oriented Instructions in Indexed Literal Offset Mode"](#) for details.

Words:            1

Cycles:           1

Q Cycle Activity:

	Q1	Q2	Q3	Q4
Decode				
Read register 'f'				
Process Data				
Write to destination				

**Example:**            SWAPF REG, 1, 0

Before Instruction

REG = 53h

After Instruction

REG = 35h

# PIC18F87J72

## TBLRD Table Read

**Syntax:** TBLRD (\*; \*+; \*-; +\*)

**Operands:** None

**Operation:** if TBLRD \*,  
(Prog Mem (TBLPTR)) → TABLAT;  
TBLPTR – No Change  
if TBLRD \*+,  
(Prog Mem (TBLPTR)) → TABLAT;  
(TBLPTR) + 1 → TBLPTR  
if TBLRD \*-,  
(Prog Mem (TBLPTR)) → TABLAT;  
(TBLPTR) – 1 → TBLPTR  
if TBLRD +\*,  
(TBLPTR) + 1 → TBLPTR;  
(Prog Mem (TBLPTR)) → TABLAT

**Status Affected:** None

**Encoding:**

0000	0000	0000	10nn nn=0 * =1 *+ =2 *- =3 +*
------	------	------	---

**Description:** This instruction is used to read the contents of Program Memory (P.M.). To address the program memory, a pointer called Table Pointer (TBLPTR) is used.

The TBLPTR (a 21-bit pointer) points to each byte in the program memory. TBLPTR has a 2-Mbyte address range.

TBLPTR<0> = 0:Least Significant Byte of Program Memory Word

TBLPTR<0> = 1:Most Significant Byte of Program Memory Word

The TBLRD instruction can modify the value of TBLPTR as follows:

- no change
- post-increment
- post-decrement
- pre-increment

**Words:** 1

**Cycles:** 2

**Q Cycle Activity:**

	Q1	Q2	Q3	Q4
Decode	No operation	No operation	No operation	No operation
No operation	No operation (Read Program Memory)	No operation	No operation (Write TABLAT)	

## TBLRD Table Read (Continued)

**Example 1:** TBLRD \*+ ;

**Before Instruction**

TABLAT	=	55h
TBLPTR	=	00A356h
MEMORY(00A356h)	=	34h

**After Instruction**

TABLAT	=	34h
TBLPTR	=	00A357h

**Example 2:** TBLRD +\* ;

**Before Instruction**

TABLAT	=	AAh
TBLPTR	=	01A357h
MEMORY(01A357h)	=	12h
MEMORY(01A358h)	=	34h

**After Instruction**

TABLAT	=	34h
TBLPTR	=	01A358h



**TBLWT      Table Write**

---

Syntax:      TBLWT (\*; \*\*; \*-\*; \*\*\*)

Operands:    None

Operation:    if TBLWT\*,  
                   (TABLELAT) → Holding Register;  
                   TBLPTR – No Change  
                   if TBLWT\*+,  
                   (TABLELAT) → Holding Register;  
                   (TABLEPTR) + 1 → TBLPTR  
                   if TBLWT\*-,  
                   (TABLELAT) → Holding Register;  
                   (TABLEPTR) – 1 → TBLPTR  
                   if TBLWT\*+\*,  
                   (TABLEPTR) + 1 → TBLPTR;  
                   (TABLELAT) → Holding Register

Status Affected: None

Encoding:    

0000	0000	0000	11nn nn=0 * =1 ** =2 *- =3 +*
------	------	------	---

Description: This instruction uses the 3 LSBs of TBLPTR to determine which of the 8 holding registers the TABLAT is written to. The holding registers are used to program the contents of Program Memory (P.M.). (Refer to [Section 6.0 "Memory Organization"](#) for additional details on programming Flash memory.)

The TBLPTR (a 21-bit pointer) points to each byte in the program memory. TBLPTR has a 2-Mbyte address range. The LSb of the TBLPTR selects which byte of the program memory location to access.

TBLPTR[0] = 0: Least Significant Byte of Program Memory Word

TBLPTR[0] = 1: Most Significant Byte of Program Memory Word

The TBLWT instruction can modify the value of TBLPTR as follows:

- no change
- post-increment
- post-decrement
- pre-increment

Words:      1

Cycles:      2

Q Cycle Activity:

	Q1	Q2	Q3	Q4
Decode	No operation	No operation	No operation	No operation
No operation	No operation	No operation (Read TABLAT)	No operation	No operation (Write to Holding Register)

**TBLWT      Table Write (Continued)**

---

Example 1:      TBLWT \*\*;

Before Instruction

TABLAT	=	55h
TBLPTR	=	00A356h
HOLDING REGISTER (00A356h)	=	FFh

After Instructions (table write completion)

TABLAT	=	55h
TBLPTR	=	00A357h
HOLDING REGISTER (00A356h)	=	55h

Example 2:      TBLWT \*+;

Before Instruction

TABLAT	=	34h
TBLPTR	=	01389Ah
HOLDING REGISTER (01389Ah)	=	FFh
HOLDING REGISTER (01389Bh)	=	FFh

After Instruction (table write completion)

TABLAT	=	34h
TBLPTR	=	01389Bh
HOLDING REGISTER (01389Ah)	=	FFh
HOLDING REGISTER (01389Bh)	=	34h

# PIC18F87J72

**TSTFSZ**                    **Test f, Skip if 0**

---

Syntax:                    TSTFSZ f {,a}

Operands:                 $0 \leq f \leq 255$   
 $a \in [0,1]$

Operation:                skip if  $f = 0$

Status Affected:        None

Encoding:                

0110	011a	ffff	ffff
------	------	------	------

Description:             If 'f' = 0, the next instruction fetched during the current instruction execution is discarded and a NOP is executed, making this a 2-cycle instruction.

                              If 'a' is '0', the Access Bank is selected. If 'a' is '1', the BSR is used to select the GPR bank.

                              If 'a' is '0' and the extended instruction set is enabled, this instruction operates in Indexed Literal Offset Addressing mode whenever  $f \leq 95$  (5Fh). See [Section 27.2.3 "Byte-Oriented and Bit-Oriented Instructions in Indexed Literal Offset Mode"](#) for details.

Words:                    1

Cycles:                    1(2)

**Note:** 3 cycles if skip and followed by a 2-word instruction.

Q Cycle Activity:

Q1	Q2	Q3	Q4
Decode	Read register 'f'	Process Data	No operation

If skip:

Q1	Q2	Q3	Q4
No operation	No operation	No operation	No operation

If skip and followed by 2-word instruction:

Q1	Q2	Q3	Q4
No operation	No operation	No operation	No operation
No operation	No operation	No operation	No operation

**Example:**

```

HERE    TSTFSZ   CNT, 1
NZERO   :
ZERO    :
    
```

Before Instruction  
PC = Address (HERE)

After Instruction  
If CNT = 00h,  
PC = Address (ZERO)  
If CNT  $\neq$  00h,  
PC = Address (NZERO)

**XORLW**                    **Exclusive OR Literal with W**

---

Syntax:                    XORLW k

Operands:                 $0 \leq k \leq 255$

Operation:                (W) .XOR. k  $\rightarrow$  W

Status Affected:        N, Z

Encoding:                

0000	1010	kkkk	kkkk
------	------	------	------

Description:             The contents of W are XORed with the 8-bit literal 'k'. The result is placed in W.

Words:                    1

Cycles:                    1

Q Cycle Activity:

Q1	Q2	Q3	Q4
Decode	Read literal 'k'	Process Data	Write to W

**Example:**

```

XORLW    0AFh
    
```

Before Instruction  
W = B5h

After Instruction  
W = 1Ah

## XORWF Exclusive OR W with f

Syntax: XORWF f {,d {,a}}

Operands:  $0 \leq f \leq 255$   
 $d \in [0,1]$   
 $a \in [0,1]$

Operation: (W) .XOR. (f) → dest

Status Affected: N, Z

Encoding: 

0001	10da	ffff	ffff
------	------	------	------

Description: Exclusive OR the contents of W with register 'f'. If 'd' is '0', the result is stored in W. If 'd' is '1', the result is stored back in the register 'f'.

If 'a' is '0', the Access Bank is selected.  
 If 'a' is '1', the BSR is used to select the GPR bank.

If 'a' is '0' and the extended instruction set is enabled, this instruction operates in Indexed Literal Offset Addressing mode whenever  $f \leq 95$  (5Fh). See [Section 27.2.3 "Byte-Oriented and Bit-Oriented Instructions in Indexed Literal Offset Mode"](#) for details.

Words: 1

Cycles: 1

Q Cycle Activity:

Q1	Q2	Q3	Q4
Decode	Read register 'f'	Process Data	Write to destination

Example: XORWF REG, 1, 0

Before Instruction

REG = AFh  
 W = B5h

After Instruction

REG = 1Ah  
 W = B5h

# PIC18F87J72

## 27.2 Extended Instruction Set

In addition to the standard 75 instructions of the PIC18 instruction set, the PIC18F87J72 family of devices also provides an optional extension to the core CPU functionality. The added features include eight additional instructions that augment Indirect and Indexed Addressing operations and the implementation of Indexed Literal Offset Addressing for many of the standard PIC18 instructions.

The additional features of the extended instruction set are enabled by default on unprogrammed devices. Users must properly set or clear the XINST Configuration bit during programming to enable or disable these features.

The instructions in the extended set can all be classified as literal operations, which either manipulate the File Select Registers, or use them for Indexed Addressing. Two of the instructions, `ADDFSR` and `SUBFSR`, each have an additional special instantiation for using FSR2. These versions (`ADDULNK` and `SUBULNK`) allow for automatic return after execution.

The extended instructions are specifically implemented to optimize re-entrant program code (that is, code that is recursive or that uses a software stack) written in high-level languages, particularly C. Among other things, they allow users working in high-level languages to perform certain operations on data structures more efficiently. These include:

- Dynamic allocation and deallocation of software stack space when entering and leaving subroutines
- Function Pointer invocation
- Software Stack Pointer manipulation
- Manipulation of variables located in a software stack

A summary of the instructions in the extended instruction set is provided in [Table 27-3](#). Detailed descriptions are provided in [Section 27.2.2 “Extended Instruction Set”](#). The opcode field descriptions in [Table 27-1](#) (page 322) apply to both the standard and extended PIC18 instruction sets.

**Note:** The instruction set extension and the Indexed Literal Offset Addressing mode were designed for optimizing applications written in C; the user may likely never use these instructions directly in assembler. The syntax for these commands is provided as a reference for users who may be reviewing code that has been generated by a compiler.

### 27.2.1 EXTENDED INSTRUCTION SYNTAX

Most of the extended instructions use indexed arguments, using one of the File Select Registers and some offset to specify a source or destination register. When an argument for an instruction serves as part of Indexed Addressing, it is enclosed in square brackets (“[]”). This is done to indicate that the argument is used as an index or offset. The MPASM™ Assembler will flag an error if it determines that an index or offset value is not bracketed.

When the extended instruction set is enabled, brackets are also used to indicate index arguments in byte-oriented and bit-oriented instructions. This is in addition to other changes in their syntax. For more details, see [Section 27.2.3.1 “Extended Instruction Syntax with Standard PIC18 Commands”](#).

**Note:** In the past, square brackets have been used to denote optional arguments in the PIC18 and earlier instruction sets. In this text and going forward, optional arguments are denoted by braces (“{}”).

**TABLE 27-3: EXTENSIONS TO THE PIC18 INSTRUCTION SET**

Mnemonic, Operands	Description	Cycles	16-Bit Instruction Word				Status Affected
			MSb		LSb		
<code>ADDFSR</code> f, k	Add Literal to FSR	1	1110	1000	kkkk		None
<code>ADDULNK</code> k	Add Literal to FSR2 and Return	2	1110	1000	ffkk	kkkk	None
<code>CALLW</code>	Call Subroutine using WREG	2	0000	0000	0100		None
<code>MOVSF</code> z <sub>s</sub> , f <sub>d</sub>	Move z <sub>s</sub> (source) to 1st word f <sub>d</sub> (destination) 2nd word	2	1110	1011	11kk	zzzz	None
<code>MOVSS</code> z <sub>s</sub> , z <sub>d</sub>	Move z <sub>s</sub> (source) to 1st word z <sub>d</sub> (destination) 2nd word	2	1110	1011	0001	zzzz	None
<code>PUSHL</code> k	Store Literal at FSR2, Decrement FSR2	1	1110	1010	ffff	kkkk	None
<code>SUBFSR</code> f, k	Subtract Literal from FSR	1	1110	1001	xzzz	kkkk	None
<code>SUBULNK</code> k	Subtract Literal from FSR2 and return	2	1110	1001	kkkk	kkkk	None
					ffkk		
					11kk		

## 27.2.2 EXTENDED INSTRUCTION SET

<b>ADDFSR</b>	<b>Add Literal to FSR</b>								
Syntax:	ADDFSR f, k								
Operands:	$0 \leq k \leq 63$ $f \in [0, 1, 2]$								
Operation:	$FSR(f) + k \rightarrow FSR(f)$								
Status Affected:	None								
Encoding:	<table border="1"><tr><td>1110</td><td>1000</td><td>ffkk</td><td>kkkk</td></tr></table>	1110	1000	ffkk	kkkk				
1110	1000	ffkk	kkkk						
Description:	The 6-bit literal 'k' is added to the contents of the FSR specified by 'f'.								
Words:	1								
Cycles:	1								
Q Cycle Activity:									
	<table border="1"><thead><tr><th>Q1</th><th>Q2</th><th>Q3</th><th>Q4</th></tr></thead><tbody><tr><td>Decode</td><td>Read literal 'k'</td><td>Process Data</td><td>Write to FSR</td></tr></tbody></table>	Q1	Q2	Q3	Q4	Decode	Read literal 'k'	Process Data	Write to FSR
Q1	Q2	Q3	Q4						
Decode	Read literal 'k'	Process Data	Write to FSR						

**Example:**           ADDFSR 2, 23h

Before Instruction  
FSR2 = 03FFh

After Instruction  
FSR2 = 0422h

<b>ADDLNK</b>	<b>Add Literal to FSR2 and Return</b>												
Syntax:	ADDLNK k												
Operands:	$0 \leq k \leq 63$												
Operation:	$FSR2 + k \rightarrow FSR2$ , (TOS) $\rightarrow$ PC												
Status Affected:	None												
Encoding:	<table border="1"><tr><td>1110</td><td>1000</td><td>11kk</td><td>kkkk</td></tr></table>	1110	1000	11kk	kkkk								
1110	1000	11kk	kkkk										
Description:	The 6-bit literal 'k' is added to the contents of FSR2. A RETURN is then executed by loading the PC with the TOS.  The instruction takes two cycles to execute; a NOP is performed during the second cycle.  This may be thought of as a special case of the ADDFSR instruction, where $f = 3$ (binary '11'); it operates only on FSR2.												
Words:	1												
Cycles:	2												
Q Cycle Activity:													
	<table border="1"><thead><tr><th>Q1</th><th>Q2</th><th>Q3</th><th>Q4</th></tr></thead><tbody><tr><td>Decode</td><td>Read literal 'k'</td><td>Process Data</td><td>Write to FSR</td></tr><tr><td>No Operation</td><td>No Operation</td><td>No Operation</td><td>No Operation</td></tr></tbody></table>	Q1	Q2	Q3	Q4	Decode	Read literal 'k'	Process Data	Write to FSR	No Operation	No Operation	No Operation	No Operation
Q1	Q2	Q3	Q4										
Decode	Read literal 'k'	Process Data	Write to FSR										
No Operation	No Operation	No Operation	No Operation										

**Example:**           ADDLNK 23h

Before Instruction  
FSR2 = 03FFh  
PC = 0100h

After Instruction  
FSR2 = 0422h  
PC = (TOS)

**Note:** All PIC18 instructions may take an optional label argument preceding the instruction mnemonic for use in symbolic addressing. If a label is used, the instruction format then becomes: {label} instruction argument(s).

# PIC18F87J72

## CALLW Subroutine Call Using WREG

**Syntax:** CALLW

**Operands:** None

**Operation:** (PC + 2) → TOS,  
(W) → PCL,  
(PCLATH) → PCH,  
(PCLATU) → PCU

**Status Affected:** None

**Encoding:**

0000	0000	0001	0100
------	------	------	------

**Description** First, the return address (PC + 2) is pushed onto the return stack. Next, the contents of W are written to PCL; the existing value is discarded. Then, the contents of PCLATH and PCLATU are latched into PCH and PCU, respectively. The second cycle is executed as a NOP instruction while the new next instruction is fetched.

Unlike CALL, there is no option to update W, STATUS or BSR.

**Words:** 1

**Cycles:** 2

Q Cycle Activity:

	Q1	Q2	Q3	Q4
Decode	Decode	Read WREG	Push PC to stack	No operation
No operation	No operation	No operation	No operation	No operation

**Example:**           HERE       CALLW

Before Instruction

PC = address (HERE)  
PCLATH = 10h  
PCLATU = 00h  
W = 06h

After Instruction

PC = 001006h  
TOS = address (HERE + 2)  
PCLATH = 10h  
PCLATU = 00h  
W = 06h

## MOVSF Move Indexed to f

**Syntax:** MOVSF [z<sub>s</sub>], f<sub>d</sub>

**Operands:** 0 ≤ z<sub>s</sub> ≤ 127  
0 ≤ f<sub>d</sub> ≤ 4095

**Operation:** ((FSR2) + z<sub>s</sub>) → f<sub>d</sub>

**Status Affected:** None

**Encoding:**

1110	1011	0zzz	zzzz <sub>s</sub>
1111	ffff	ffff	ffff <sub>d</sub>

**Description:** The contents of the source register are moved to destination register 'f<sub>d</sub>'. The actual address of the source register is determined by adding the 7-bit literal offset 'z<sub>s</sub>', in the first word, to the value of FSR2. The address of the destination register is specified by the 12-bit literal 'f<sub>d</sub>' in the second word. Both addresses can be anywhere in the 4096-byte data space (000h to FFFh).

The MOVSF instruction cannot use the PCL, TOSU, TOSH or TOSL as the destination register.

If the resultant source address points to an Indirect Addressing register, the value returned will be 00h.

**Words:** 2

**Cycles:** 2

Q Cycle Activity:

	Q1	Q2	Q3	Q4
Decode	Decode	Determine source addr	Determine source addr	Read source reg
Decode	Decode	No operation No dummy read	No operation	Write register 'f' (dest)

**Example:**           MOVSF [05h], REG2

Before Instruction

FSR2 = 80h  
Contents of 85h = 33h  
REG2 = 11h

After Instruction

FSR2 = 80h  
Contents of 85h = 33h  
REG2 = 33h

**MOVSS**                      **Move Indexed to Indexed**

---

Syntax:                      MOVSS [z<sub>s</sub>], [z<sub>d</sub>]

Operands:                    0 ≤ z<sub>s</sub> ≤ 127  
                                   0 ≤ z<sub>d</sub> ≤ 127

Operation:                   ((FSR2) + z<sub>s</sub>) → ((FSR2) + z<sub>d</sub>)

Status Affected:           None

Encoding:                    

1110	1011	1zzz	zzzz <sub>s</sub>
1111	xxxx	xzzz	zzzz <sub>d</sub>

1st word (source)

2nd word (dest.)

Description

The contents of the source register are moved to the destination register. The addresses of the source and destination registers are determined by adding the 7-bit literal offsets, 'z<sub>s</sub>' or 'z<sub>d</sub>', respectively, to the value of FSR2. Both registers can be located anywhere in the 4096-byte data memory space (000h to FFFh).

The MOVSS instruction cannot use the PCL, TOSU, TOSH or TOSL as the destination register.

If the resultant source address points to an Indirect Addressing register, the value returned will be 00h. If the resultant destination address points to an Indirect Addressing register, the instruction will execute as a NOP.

Words:                        2

Cycles:                        2

Q Cycle Activity:

Q1	Q2	Q3	Q4
Decode	Determine source addr	Determine source addr	Read source reg
Decode	Determine dest addr	Determine dest addr	Write to dest reg

**Example:**                    MOVSS [05h], [06h]

Before Instruction

FSR2                        = 80h

Contents of 85h            = 33h

Contents of 86h            = 11h

After Instruction

FSR2                        = 80h

Contents of 85h            = 33h

Contents of 86h            = 33h

**PUSHL**                      **Store Literal at FSR2, Decrement FSR2**

---

Syntax:                      PUSHL k

Operands:                    0 ≤ k ≤ 255

Operation:                    k → (FSR2),  
                                   FSR2 - 1 → FSR2

Status Affected:           None

Encoding:                    

1111	1010	kkkk	kkkk
------	------	------	------

Description:

The 8-bit literal 'k' is written to the data memory address specified by FSR2. FSR2 is decremented by 1 after the operation.

This instruction allows users to push values onto a software stack.

Words:                        1

Cycles:                        1

Q Cycle Activity:

Q1	Q2	Q3	Q4
Decode	Read 'k'	Process data	Write to destination

**Example:**                    PUSHL 08h

Before Instruction

FSR2H:FSR2L              = 01ECh

Memory (01ECh)            = 00h

After Instruction

FSR2H:FSR2L              = 01EBh

Memory (01ECh)            = 08h

# PIC18F87J72

## SUBFSR Subtract Literal from FSR

Syntax: SUBFSR f, k  
 Operands:  $0 \leq k \leq 63$   
 $f \in [0, 1, 2]$   
 Operation:  $FSRf - k \rightarrow FSRf$   
 Status Affected: None  
 Encoding: 

1110	1001	ffkk	kkkk
------	------	------	------

  
 Description: The 6-bit literal 'k' is subtracted from the contents of the FSR specified by 'f'.  
 Words: 1  
 Cycles: 1  
 Q Cycle Activity:

Q1	Q2	Q3	Q4
Decode	Read register 'f'	Process Data	Write to destination

Example: SUBFSR 2, 23h

Before Instruction  
 FSR2 = 03FFh  
 After Instruction  
 FSR2 = 03DCh

## SUBULNK Subtract Literal from FSR2 and Return

Syntax: SUBULNK k  
 Operands:  $0 \leq k \leq 63$   
 Operation:  $FSR2 - k \rightarrow FSR2$ ,  
 (TOS)  $\rightarrow$  PC  
 Status Affected: None  
 Encoding: 

1110	1001	11kk	kkkk
------	------	------	------

  
 Description: The 6-bit literal 'k' is subtracted from the contents of the FSR2. A RETURN is then executed by loading the PC with the TOS.  
 The instruction takes two cycles to execute; a NOP is performed during the second cycle.  
 This may be thought of as a special case of the SUBFSR instruction, where  $f = 3$  (binary '11'); it operates only on FSR2.  
 Words: 1  
 Cycles: 2  
 Q Cycle Activity:

Q1	Q2	Q3	Q4
Decode	Read register 'f'	Process Data	Write to destination
No Operation	No Operation	No Operation	No Operation

Example: SUBULNK 23h

Before Instruction  
 FSR2 = 03FFh  
 PC = 0100h  
 After Instruction  
 FSR2 = 03DCh  
 PC = (TOS)



## 27.2.3 BYTE-ORIENTED AND BIT-ORIENTED INSTRUCTIONS IN INDEXED LITERAL OFFSET MODE

**Note:** Enabling the PIC18 instruction set extension may cause legacy applications to behave erratically or fail entirely.

In addition to eight new commands in the extended set, enabling the extended instruction set also enables Indexed Literal Offset Addressing ([Section 6.5.1 “Indexed Addressing with Literal Offset”](#)). This has a significant impact on the way that many commands of the standard PIC18 instruction set are interpreted.

When the extended set is disabled, addresses embedded in opcodes are treated as literal memory locations: either as a location in the Access Bank ( $a = 0$ ) or in a GPR bank designated by the BSR ( $a = 1$ ). When the extended instruction set is enabled and  $a = 0$ , however, a file register argument of 5Fh or less is interpreted as an offset from the pointer value in FSR2 and not as a literal address. For practical purposes, this means that all instructions that use the Access RAM bit as an argument – that is, all byte-oriented and bit-oriented instructions, or almost half of the core PIC18 instructions – may behave differently when the extended instruction set is enabled.

When the content of FSR2 is 00h, the boundaries of the Access RAM are essentially remapped to their original values. This may be useful in creating backward-compatible code. If this technique is used, it may be necessary to save the value of FSR2 and restore it when moving back and forth between C and assembly routines in order to preserve the Stack Pointer. Users must also keep in mind the syntax requirements of the extended instruction set (see [Section 27.2.3.1 “Extended Instruction Syntax with Standard PIC18 Commands”](#)).

Although the Indexed Literal Offset mode can be very useful for dynamic stack and pointer manipulation, it can also be very annoying if a simple arithmetic operation is carried out on the wrong register. Users who are accustomed to the PIC18 programming must keep in mind that, when the extended instruction set is enabled, register addresses of 5Fh or less are used for Indexed Literal Offset Addressing.

Representative examples of typical byte-oriented and bit-oriented instructions in the Indexed Literal Offset mode are provided on the following page to show how execution is affected. The operand conditions shown in the examples are applicable to all instructions of these types.

### 27.2.3.1 Extended Instruction Syntax with Standard PIC18 Commands

When the extended instruction set is enabled, the file register argument ‘f’ in the standard byte-oriented and bit-oriented commands is replaced with the literal offset value ‘k’. As already noted, this occurs only when ‘f’ is less than or equal to 5Fh. When an offset value is used, it must be indicated by square brackets (“[ ]”). As with the extended instructions, the use of brackets indicates to the compiler that the value is to be interpreted as an index or an offset. Omitting the brackets, or using a value greater than 5Fh within the brackets, will generate an error in the MPASM™ Assembler.

If the index argument is properly bracketed for Indexed Literal Offset Addressing, the Access RAM argument is never specified; it will automatically be assumed to be ‘0’. This is in contrast to standard operation (extended instruction set disabled), when ‘a’ is set on the basis of the target address. Declaring the Access RAM bit in this mode will also generate an error in the MPASM Assembler.

The destination argument ‘d’ functions as before.

In the latest versions of the MPASM Assembler, language support for the extended instruction set must be explicitly invoked. This is done with either the command line option, `/y`, or the PE directive in the source listing.

## 27.2.4 CONSIDERATIONS WHEN ENABLING THE EXTENDED INSTRUCTION SET

It is important to note that the extensions to the instruction set may not be beneficial to all users. In particular, users who are not writing code that uses a software stack may not benefit from using the extensions to the instruction set.

Additionally, the Indexed Literal Offset Addressing mode may create issues with legacy applications written to the PIC18 assembler. This is because instructions in the legacy code may attempt to address registers in the Access Bank below 5Fh. Since these addresses are interpreted as literal offsets to FSR2 when the instruction set extension is enabled, the application may read or write to the wrong data addresses.

When porting an application to the PIC18F87J72 family, it is very important to consider the type of code. A large, re-entrant application that is written in C and would benefit from efficient compilation will do well when using the instruction set extensions. Legacy applications that heavily use the Access Bank will most likely not benefit from using the extended instruction set.

# PIC18F87J72

ADDWF	ADD W to Indexed (Indexed Literal Offset mode)								
Syntax:	ADDWF [k] {,d}								
Operands:	$0 \leq k \leq 95$ $d \in [0,1]$								
Operation:	$(W) + ((FSR2) + k) \rightarrow dest$								
Status Affected:	N, OV, C, DC, Z								
Encoding:	<table border="1"><tr><td>0010</td><td>01d0</td><td>kkkk</td><td>kkkk</td></tr></table>	0010	01d0	kkkk	kkkk				
0010	01d0	kkkk	kkkk						
Description:	The contents of W are added to the contents of the register indicated by FSR2, offset by the value 'k'.  If 'd' is '0', the result is stored in W. If 'd' is '1', the result is stored back in register 'f'.								
Words:	1								
Cycles:	1								
Q Cycle Activity:	<table border="1"><thead><tr><th>Q1</th><th>Q2</th><th>Q3</th><th>Q4</th></tr></thead><tbody><tr><td>Decode</td><td>Read 'k'</td><td>Process Data</td><td>Write to destination</td></tr></tbody></table>	Q1	Q2	Q3	Q4	Decode	Read 'k'	Process Data	Write to destination
Q1	Q2	Q3	Q4						
Decode	Read 'k'	Process Data	Write to destination						

**Example:** ADDWF [OFST], 0

Before Instruction		
W	=	17h
OFST	=	2Ch
FSR2	=	0A00h
Contents of 0A2Ch	=	20h
After Instruction		
W	=	37h
Contents of 0A2Ch	=	20h

BSF	Bit Set Indexed (Indexed Literal Offset mode)								
Syntax:	BSF [k], b								
Operands:	$0 \leq f \leq 95$ $0 \leq b \leq 7$								
Operation:	$1 \rightarrow ((FSR2) + k) <b>$								
Status Affected:	None								
Encoding:	<table border="1"><tr><td>1000</td><td>bbb0</td><td>kkkk</td><td>kkkk</td></tr></table>	1000	bbb0	kkkk	kkkk				
1000	bbb0	kkkk	kkkk						
Description:	Bit 'b' of the register indicated by FSR2, offset by the value 'k', is set.								
Words:	1								
Cycles:	1								
Q Cycle Activity:	<table border="1"><thead><tr><th>Q1</th><th>Q2</th><th>Q3</th><th>Q4</th></tr></thead><tbody><tr><td>Decode</td><td>Read register 'f'</td><td>Process Data</td><td>Write to destination</td></tr></tbody></table>	Q1	Q2	Q3	Q4	Decode	Read register 'f'	Process Data	Write to destination
Q1	Q2	Q3	Q4						
Decode	Read register 'f'	Process Data	Write to destination						

**Example:** BSF [FLAG\_OFST], 7

Before Instruction		
FLAG_OFST	=	0Ah
FSR2	=	0A00h
Contents of 0A0Ah	=	55h
After Instruction		
Contents of 0A0Ah	=	D5h

SETF	Set Indexed (Indexed Literal Offset mode)								
Syntax:	SETF [k]								
Operands:	$0 \leq k \leq 95$								
Operation:	$FFh \rightarrow ((FSR2) + k)$								
Status Affected:	None								
Encoding:	<table border="1"><tr><td>0110</td><td>1000</td><td>kkkk</td><td>kkkk</td></tr></table>	0110	1000	kkkk	kkkk				
0110	1000	kkkk	kkkk						
Description:	The contents of the register indicated by FSR2, offset by 'k', are set to FFh.								
Words:	1								
Cycles:	1								
Q Cycle Activity:	<table border="1"><thead><tr><th>Q1</th><th>Q2</th><th>Q3</th><th>Q4</th></tr></thead><tbody><tr><td>Decode</td><td>Read 'k'</td><td>Process Data</td><td>Write register</td></tr></tbody></table>	Q1	Q2	Q3	Q4	Decode	Read 'k'	Process Data	Write register
Q1	Q2	Q3	Q4						
Decode	Read 'k'	Process Data	Write register						

**Example:** SETF [OFST]

Before Instruction		
OFST	=	2Ch
FSR2	=	0A00h
Contents of 0A2Ch	=	00h
After Instruction		
Contents of 0A2Ch	=	FFh

## 27.2.5 SPECIAL CONSIDERATIONS WITH MICROCHIP MPLAB® IDE TOOLS

The latest versions of Microchip's software tools have been designed to fully support the extended instruction set for the PIC18F87J72 family. This includes the MPLAB C18 C Compiler, MPASM assembly language and MPLAB Integrated Development Environment (IDE).

When selecting a target device for software development, MPLAB IDE will automatically set default Configuration bits for that device. The default setting for the XINST Configuration bit is '1', enabling the extended instruction set and Indexed Literal Offset Addressing. For proper execution of applications developed to take advantage of the extended instruction set, XINST must be set during programming.

To develop software for the extended instruction set, the user must enable support for the instructions and the Indexed Addressing mode in their language tool(s). Depending on the environment being used, this may be done in several ways:

- A menu option or dialog box within the environment that allows the user to configure the language tool and its settings for the project
- A command line option
- A directive in the source code

These options vary between different compilers, assemblers and development environments. Users are encouraged to review the documentation accompanying their development systems for the appropriate information.

## 28.0 DEVELOPMENT SUPPORT

The PIC<sup>®</sup> microcontrollers (MCU) and dsPIC<sup>®</sup> digital signal controllers (DSC) are supported with a full range of software and hardware development tools:

- Integrated Development Environment
  - MPLAB<sup>®</sup> X IDE Software
- Compilers/Assemblers/Linkers
  - MPLAB XC Compiler
  - MPASM<sup>™</sup> Assembler
  - MPLINK<sup>™</sup> Object Linker/  
MPLIB<sup>™</sup> Object Librarian
  - MPLAB Assembler/Linker/Librarian for  
Various Device Families
- Simulators
  - MPLAB X SIM Software Simulator
- Emulators
  - MPLAB REAL ICE<sup>™</sup> In-Circuit Emulator
- In-Circuit Debuggers/Programmers
  - MPLAB ICD 3
  - PICKit<sup>™</sup> 3
- Device Programmers
  - MPLAB PM3 Device Programmer
- Low-Cost Demonstration/Development Boards,  
Evaluation Kits and Starter Kits
- Third-party development tools

## 28.1 MPLAB X Integrated Development Environment Software

The MPLAB X IDE is a single, unified graphical user interface for Microchip and third-party software, and hardware development tool that runs on Windows<sup>®</sup>, Linux and Mac OS<sup>®</sup> X. Based on the NetBeans IDE, MPLAB X IDE is an entirely new IDE with a host of free software components and plug-ins for high-performance application development and debugging. Moving between tools and upgrading from software simulators to hardware debugging and programming tools is simple with the seamless user interface.

With complete project management, visual call graphs, a configurable watch window and a feature-rich editor that includes code completion and context menus, MPLAB X IDE is flexible and friendly enough for new users. With the ability to support multiple tools on multiple projects with simultaneous debugging, MPLAB X IDE is also suitable for the needs of experienced users.

Feature-Rich Editor:

- Color syntax highlighting
- Smart code completion makes suggestions and provides hints as you type
- Automatic code formatting based on user-defined rules
- Live parsing

User-Friendly, Customizable Interface:

- Fully customizable interface: toolbars, toolbar buttons, windows, window placement, etc.
- Call graph window

Project-Based Workspaces:

- Multiple projects
- Multiple tools
- Multiple configurations
- Simultaneous debugging sessions

File History and Bug Tracking:

- Local file history feature
- Built-in support for Bugzilla issue tracker

## 28.2 MPLAB XC Compilers

The MPLAB XC Compilers are complete ANSI C compilers for all of Microchip's 8, 16, and 32-bit MCU and DSC devices. These compilers provide powerful integration capabilities, superior code optimization and ease of use. MPLAB XC Compilers run on Windows, Linux or MAC OS X.

For easy source level debugging, the compilers provide debug information that is optimized to the MPLAB X IDE.

The free MPLAB XC Compiler editions support all devices and commands, with no time or memory restrictions, and offer sufficient code optimization for most applications.

MPLAB XC Compilers include an assembler, linker and utilities. The assembler generates relocatable object files that can then be archived or linked with other relocatable object files and archives to create an executable file. MPLAB XC Compiler uses the assembler to produce its object file. Notable features of the assembler include:

- Support for the entire device instruction set
- Support for fixed-point and floating-point data
- Command-line interface
- Rich directive set
- Flexible macro language
- MPLAB X IDE compatibility

## 28.3 MPASM Assembler

The MPASM Assembler is a full-featured, universal macro assembler for PIC10/12/16/18 MCUs.

The MPASM Assembler generates relocatable object files for the MPLINK Object Linker, Intel® standard HEX files, MAP files to detail memory usage and symbol reference, absolute LST files that contain source lines and generated machine code, and COFF files for debugging.

The MPASM Assembler features include:

- Integration into MPLAB X IDE projects
- User-defined macros to streamline assembly code
- Conditional assembly for multipurpose source files
- Directives that allow complete control over the assembly process

## 28.4 MPLINK Object Linker/ MPLIB Object Librarian

The MPLINK Object Linker combines relocatable objects created by the MPASM Assembler. It can link relocatable objects from precompiled libraries, using directives from a linker script.

The MPLIB Object Librarian manages the creation and modification of library files of precompiled code. When a routine from a library is called from a source file, only the modules that contain that routine will be linked in with the application. This allows large libraries to be used efficiently in many different applications.

The object linker/librarian features include:

- Efficient linking of single libraries instead of many smaller files
- Enhanced code maintainability by grouping related modules together
- Flexible creation of libraries with easy module listing, replacement, deletion and extraction

## 28.5 MPLAB Assembler, Linker and Librarian for Various Device Families

MPLAB Assembler produces relocatable machine code from symbolic assembly language for PIC24, PIC32 and dsPIC DSC devices. MPLAB XC Compiler uses the assembler to produce its object file. The assembler generates relocatable object files that can then be archived or linked with other relocatable object files and archives to create an executable file. Notable features of the assembler include:

- Support for the entire device instruction set
- Support for fixed-point and floating-point data
- Command-line interface
- Rich directive set
- Flexible macro language
- MPLAB X IDE compatibility

## 28.6 MPLAB X SIM Software Simulator

The MPLAB X SIM Software Simulator allows code development in a PC-hosted environment by simulating the PIC MCUs and dsPIC DSCs on an instruction level. On any given instruction, the data areas can be examined or modified and stimuli can be applied from a comprehensive stimulus controller. Registers can be logged to files for further run-time analysis. The trace buffer and logic analyzer display extend the power of the simulator to record and track program execution, actions on I/O, most peripherals and internal registers.

The MPLAB X SIM Software Simulator fully supports symbolic debugging using the MPLAB XC Compilers, and the MPASM and MPLAB Assemblers. The software simulator offers the flexibility to develop and debug code outside of the hardware laboratory environment, making it an excellent, economical software development tool.

## 28.7 MPLAB REAL ICE In-Circuit Emulator System

The MPLAB REAL ICE In-Circuit Emulator System is Microchip's next generation high-speed emulator for Microchip Flash DSC and MCU devices. It debugs and programs all 8, 16 and 32-bit MCU, and DSC devices with the easy-to-use, powerful graphical user interface of the MPLAB X IDE.

The emulator is connected to the design engineer's PC using a high-speed USB 2.0 interface and is connected to the target with either a connector compatible with in-circuit debugger systems (RJ-11) or with the new high-speed, noise tolerant, Low-Voltage Differential Signal (LVDS) interconnection (CAT5).

The emulator is field upgradable through future firmware downloads in MPLAB X IDE. MPLAB REAL ICE offers significant advantages over competitive emulators including full-speed emulation, run-time variable watches, trace analysis, complex breakpoints, logic probes, a ruggedized probe interface and long (up to three meters) interconnection cables.

## 28.8 MPLAB ICD 3 In-Circuit Debugger System

The MPLAB ICD 3 In-Circuit Debugger System is Microchip's most cost-effective, high-speed hardware debugger/programmer for Microchip Flash DSC and MCU devices. It debugs and programs PIC Flash microcontrollers and dsPIC DSCs with the powerful, yet easy-to-use graphical user interface of the MPLAB IDE.

The MPLAB ICD 3 In-Circuit Debugger probe is connected to the design engineer's PC using a high-speed USB 2.0 interface and is connected to the target with a connector compatible with the MPLAB ICD 2 or MPLAB REAL ICE systems (RJ-11). MPLAB ICD 3 supports all MPLAB ICD 2 headers.

## 28.9 PICkit 3 In-Circuit Debugger/Programmer

The MPLAB PICkit 3 allows debugging and programming of PIC and dsPIC Flash microcontrollers at a most affordable price point using the powerful graphical user interface of the MPLAB IDE. The MPLAB PICkit 3 is connected to the design engineer's PC using a full-speed USB interface and can be connected to the target via a Microchip debug (RJ-11) connector (compatible with MPLAB ICD 3 and MPLAB REAL ICE). The connector uses two device I/O pins and the Reset line to implement in-circuit debugging and In-Circuit Serial Programming™ (ICSP™).

## 28.10 MPLAB PM3 Device Programmer

The MPLAB PM3 Device Programmer is a universal, CE compliant device programmer with programmable voltage verification at VDDMIN and VDDMAX for maximum reliability. It features a large LCD display (128 x 64) for menus and error messages, and a modular, detachable socket assembly to support various package types. The ICSP cable assembly is included as a standard item. In Stand-Alone mode, the MPLAB PM3 Device Programmer can read, verify and program PIC devices without a PC connection. It can also set code protection in this mode. The MPLAB PM3 connects to the host PC via an RS-232 or USB cable. The MPLAB PM3 has high-speed communications and optimized algorithms for quick programming of large memory devices, and incorporates an MMC card for file storage and data applications.

## 28.11 Demonstration/Development Boards, Evaluation Kits, and Starter Kits

A wide variety of demonstration, development and evaluation boards for various PIC MCUs and dsPIC DSCs allows quick application development on fully functional systems. Most boards include prototyping areas for adding custom circuitry and provide application firmware and source code for examination and modification.

The boards support a variety of features, including LEDs, temperature sensors, switches, speakers, RS-232 interfaces, LCD displays, potentiometers and additional EEPROM memory.

The demonstration and development boards can be used in teaching environments, for prototyping custom circuits and for learning about various microcontroller applications.

In addition to the PICDEM™ and dsPICDEM™ demonstration/development board series of circuits, Microchip has a line of evaluation kits and demonstration software for analog filter design, KEELOQ® security ICs, CAN, IrDA®, PowerSmart battery management, SEEVAL® evaluation system, Sigma-Delta ADC, flow rate sensing, plus many more.

Also available are starter kits that contain everything needed to experience the specified device. This usually includes a single application and debug capability, all on one board.

Check the Microchip web page ([www.microchip.com](http://www.microchip.com)) for the complete list of demonstration, development and evaluation kits.

## 28.12 Third-Party Development Tools

Microchip also offers a great collection of tools from third-party vendors. These tools are carefully selected to offer good value and unique functionality.

- Device Programmers and Gang Programmers from companies, such as SoftLog and CCS
- Software Tools from companies, such as Gimpel and Trace Systems
- Protocol Analyzers from companies, such as Saleae and Total Phase
- Demonstration Boards from companies, such as MikroElektronika, Digilent® and Olimex
- Embedded Ethernet Solutions from companies, such as EZ Web Lynx, WIZnet and IPLogika®

# PIC18F87J72

## 29.0 ELECTRICAL CHARACTERISTICS

### Absolute Maximum Ratings<sup>(†)</sup>

Ambient temperature under bias .....	-40°C to +100°C
Storage temperature .....	-65°C to +150°C
Voltage on any digital only I/O pin or $\overline{\text{MCLR}}$ with respect to V <sub>SS</sub> (except V <sub>DD</sub> ).....	-0.3V to 5.6V
Voltage on any combined digital and analog pin with respect to V <sub>SS</sub> (except V <sub>DD</sub> and $\overline{\text{MCLR}}$ ).....	-0.3V to (V <sub>DD</sub> + 0.3V)
Voltage on V <sub>DDCORE</sub> with respect to V <sub>SS</sub> .....	-0.3V to 2.75V
Voltage on V <sub>DD</sub> with respect to V <sub>SS</sub> .....	-0.3V to 3.6V
Total power dissipation ( <b>Note 1</b> ).....	1.0W
Maximum current out of V <sub>SS</sub> pin .....	300 mA
Maximum current into V <sub>DD</sub> pin .....	250 mA
Maximum output current sunk by PORTA<7:6> and any PORTB and PORTC I/O pins.....	25 mA
Maximum output current sunk by any PORTD, PORTE and PORTJ I/O pins .....	8 mA
Maximum output current sunk by PORTA<5:0> and any PORTF, PORTG and PORTH I/O pins.....	2 mA
Maximum output current sourced by PORTA<7:6> and any PORTB and PORTC I/O pins.....	25 mA
Maximum output current sourced by any PORTD, PORTE and PORTJ I/O pins .....	8 mA
Maximum output current sourced by PORTA<5:0> and any PORTF, PORTG and PORTH I/O pins .....	2 mA
Maximum current sunk by all ports combined .....	200 mA
Voltage on AFE SV <sub>DD</sub> .....	7.0V
AFE digital inputs and outputs with respect to SAV <sub>SS</sub> .....	-0.6V to (SV <sub>DD</sub> + 0.6V)
AFE analog input with respect to SAV <sub>SS</sub> .....	-6V to +6V
AFE V <sub>REF</sub> input with respect to SAV <sub>SS</sub> .....	-0.6V to (SV <sub>DD</sub> + 0.6V)
ESD on the AFE analog inputs (HBM <sup>(2)</sup> ,MM <sup>(3)</sup> ) .....	7.0 kV, 400V
ESD on all other AFE pins (HBM <sup>(2)</sup> ,MM <sup>(3)</sup> ) .....	7.0 kV, 400V

**Note 1:** Power dissipation is calculated as follows:

$$P_{dis} = V_{DD} \times \{I_{DD} - \sum I_{OH}\} + \sum \{(V_{DD} - V_{OH}) \times I_{OH}\} + \sum (V_{OL} \times I_{OL})$$

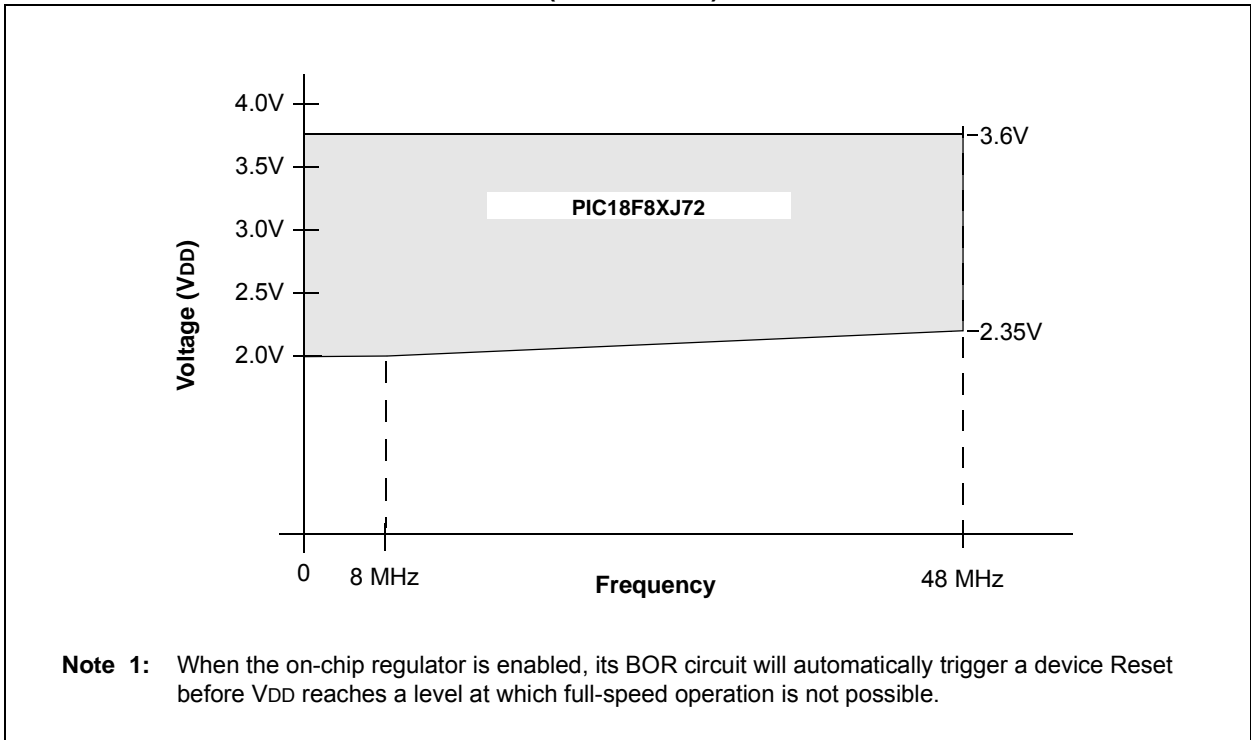
**2:** Human Body Model for ESD testing.

**3:** Machine Model for ESD testing.

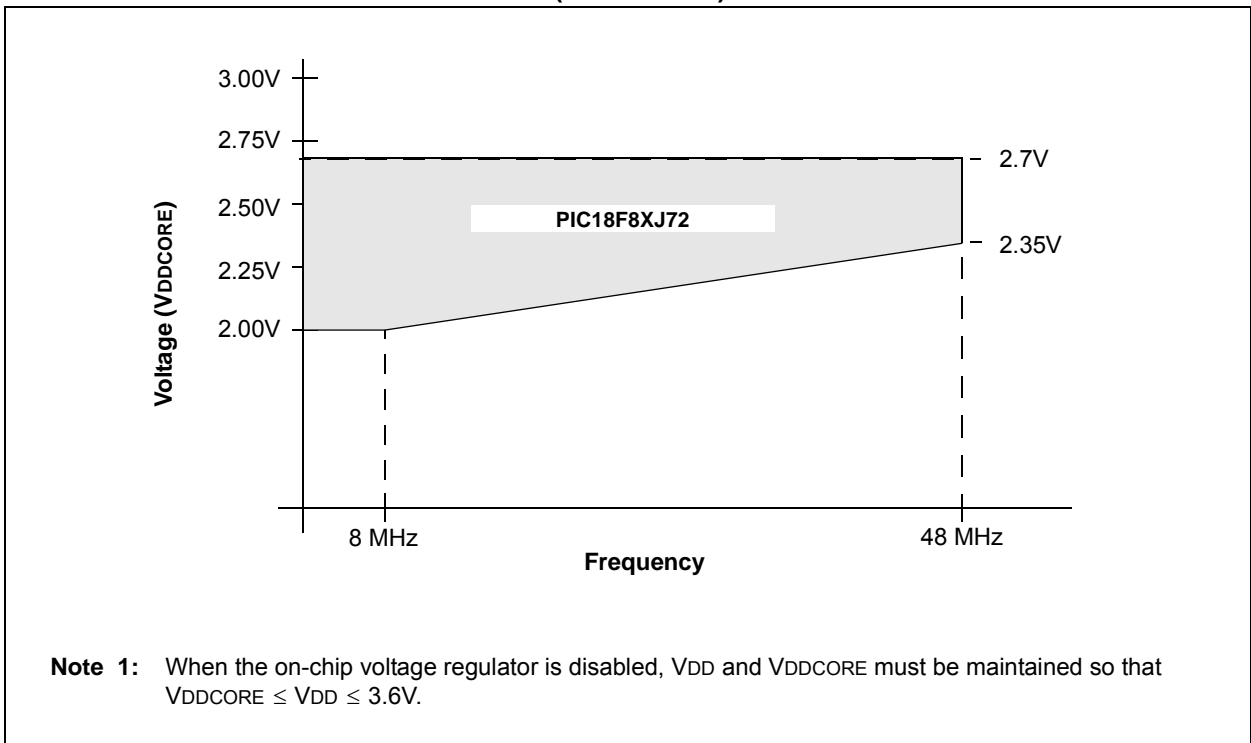
† **NOTICE:** Stresses above those listed under “Absolute Maximum Ratings” may cause permanent damage to the device. This is a stress rating only and functional operation of the device at those or any other conditions above those indicated in the operation listings of this specification is not implied. Exposure to maximum rating conditions for extended periods may affect device reliability.



**FIGURE 29-1: VOLTAGE-FREQUENCY GRAPH, REGULATOR ENABLED (INDUSTRIAL)<sup>(1)</sup>**



**FIGURE 29-2: VOLTAGE-FREQUENCY GRAPH, REGULATOR DISABLED (INDUSTRIAL)<sup>(1)</sup>**



# PIC18F87J72

## DC Characteristics: Supply Voltage PIC18F87J72 Family (Industrial)

PIC18F87J72 Family (Industrial)		Standard Operating Conditions (unless otherwise stated) Operating temperature $-40^{\circ}\text{C} \leq T_A \leq +85^{\circ}\text{C}$ for industrial					
Param No.	Symbol	Characteristic	Min.	Typ.	Max.	Units	Conditions
D001	VDD	Supply Voltage	VDDCORE 2.0	—	3.6 3.6	V V	ENVREG tied to VSS ENVREG tied to VDD
D001B	VDDCORE	External Supply for Microcontroller Core	2.0	—	2.70	V	ENVREG tied to VSS
D001C	AVDD	Analog Supply Voltage	VDD – 0.3	—	VDD + 0.3	V	
D001D	AVSS	Analog Ground Potential	VSS – 0.3	—	VSS + 0.3	V	
D002	VDR	RAM Data Retention Voltage <sup>(1)</sup>	1.5	—	—	V	
D003	VPOR	VDD Start Voltage to Ensure Internal Power-on Reset Signal	—	—	0.7	V	See <a href="#">Section 5.3 “Power-on Reset (POR)”</a> for details
D004	SVDD	VDD Rise Rate to Ensure Internal Power-on Reset Signal	0.05	—	—	V/ms	See <a href="#">Section 5.3 “Power-on Reset (POR)”</a> for details
D005	VBOR	Brown-out Reset Voltage	—	1.8	—	V	

**Note 1:** This is the limit to which VDD can be lowered in Sleep mode, or during a device Reset, without losing RAM data.

## 29.1 DC Characteristics: Power-Down and Supply Current PIC18F87J72 Family (Industrial)

PIC18F87J72 Family (Industrial)		Standard Operating Conditions (unless otherwise stated) Operating temperature $-40^{\circ}\text{C} \leq T_A \leq +85^{\circ}\text{C}$ for industrial			
Param. No.	Device	Typ.	Max.	Units	Conditions
<b>Power-Down Current (<math>I_{PD}</math>)<sup>(1)</sup></b>					
	All devices	0.5	1.4	$\mu\text{A}$	$-40^{\circ}\text{C}$
		0.1	1.4	$\mu\text{A}$	$+25^{\circ}\text{C}$
		0.8	6	$\mu\text{A}$	$+60^{\circ}\text{C}$
		5.5	10.2	$\mu\text{A}$	$+85^{\circ}\text{C}$
					$V_{DD} = 2.0\text{V}^{(4)}$ (Sleep mode)
	All devices	0.5	1.5	$\mu\text{A}$	$-40^{\circ}\text{C}$
		0.1	1.5	$\mu\text{A}$	$+25^{\circ}\text{C}$
		1	8	$\mu\text{A}$	$+60^{\circ}\text{C}$
		6.8	12.6	$\mu\text{A}$	$+85^{\circ}\text{C}$
					$V_{DD} = 2.5\text{V}^{(4)}$ (Sleep mode)
	All devices	2.9	7	$\mu\text{A}$	$-40^{\circ}\text{C}$
		3.6	7	$\mu\text{A}$	$+25^{\circ}\text{C}$
		4.1	10	$\mu\text{A}$	$+60^{\circ}\text{C}$
		9.6	19	$\mu\text{A}$	$+85^{\circ}\text{C}$
					$V_{DD} = 3.3\text{V}^{(5)}$ (Sleep mode)

- Note 1:** The power-down current in Sleep mode does not depend on the oscillator type. Power-down current is measured with the part in Sleep mode, with all I/O pins in high-impedance state and tied to  $V_{DD}$  or  $V_{SS}$  and all features that add delta current disabled (such as WDT, Timer1 oscillator, BOR, etc.).
- 2:** The supply current is mainly a function of operating voltage, frequency and mode. Other factors, such as I/O pin loading and switching rate, oscillator type and circuit, internal code execution pattern and temperature, also have an impact on the current consumption.  
The test conditions for all  $I_{DD}$  measurements in active operation mode are:  
OSC1 = external square wave, from rail-to-rail; all I/O pins tri-stated, pulled to  $V_{DD}$ ;  
MCLR =  $V_{DD}$ ; WDT enabled/disabled as specified.
- 3:** Standard, low-cost 32 kHz crystals have an operating temperature range of  $-10^{\circ}\text{C}$  to  $+70^{\circ}\text{C}$ . Extended temperature crystals are available at a much higher cost.
- 4:** Voltage regulator is disabled (ENVREG = 0, tied to  $V_{SS}$ ).
- 5:** Voltage regulator is enabled (ENVREG = 1, tied to  $V_{DD}$ , REGSLP = 1).

# PIC18F87J72

## 29.1 DC Characteristics: Power-Down and Supply Current PIC18F87J72 Family (Industrial) (Continued)

PIC18F87J72 Family (Industrial)		Standard Operating Conditions (unless otherwise stated) Operating temperature $-40^{\circ}\text{C} \leq T_A \leq +85^{\circ}\text{C}$ for industrial				
Param. No.	Device	Typ.	Max.	Units	Conditions	
<b>Supply Current (<math>I_{DD}</math>)<sup>(2,3)</sup></b>						
All devices		5	14.2	$\mu\text{A}$	$-40^{\circ}\text{C}$	$V_{DD} = 2.0\text{V}$ , $V_{DDCORE} = 2.0\text{V}^{(4)}$  $V_{DD} = 2.5\text{V}$ , $V_{DDCORE} = 2.5\text{V}^{(4)}$  $V_{DD} = 3.3\text{V}^{(5)}$  $V_{DD} = 2.0\text{V}$ , $V_{DDCORE} = 2.0\text{V}^{(4)}$  $V_{DD} = 2.5\text{V}$ , $V_{DDCORE} = 2.5\text{V}^{(4)}$  $V_{DD} = 3.3\text{V}^{(5)}$  $V_{DD} = 2.0\text{V}$ , $V_{DDCORE} = 2.0\text{V}^{(4)}$  $V_{DD} = 2.5\text{V}$ , $V_{DDCORE} = 2.5\text{V}^{(4)}$  $V_{DD} = 3.3\text{V}^{(5)}$
		5.5	14.2	$\mu\text{A}$	$+25^{\circ}\text{C}$	
		10	19.0	$\mu\text{A}$	$+85^{\circ}\text{C}$	
All devices		6.8	16.5	$\mu\text{A}$	$-40^{\circ}\text{C}$	
		7.6	16.5	$\mu\text{A}$	$+25^{\circ}\text{C}$	
		14	22.4	$\mu\text{A}$	$+85^{\circ}\text{C}$	
All devices		37	84	$\mu\text{A}$	$-40^{\circ}\text{C}$	
		51	84	$\mu\text{A}$	$+25^{\circ}\text{C}$	
		72	108	$\mu\text{A}$	$+85^{\circ}\text{C}$	
All devices		0.43	0.82	$\text{mA}$	$-40^{\circ}\text{C}$	
		0.47	0.82	$\text{mA}$	$+25^{\circ}\text{C}$	
		0.52	0.95	$\text{mA}$	$+85^{\circ}\text{C}$	
All devices		0.52	0.98	$\text{mA}$	$-40^{\circ}\text{C}$	
		0.57	0.98	$\text{mA}$	$+25^{\circ}\text{C}$	
		0.63	1.10	$\text{mA}$	$+85^{\circ}\text{C}$	
All devices		0.59	0.96	$\text{mA}$	$-40^{\circ}\text{C}$	
		0.65	0.96	$\text{mA}$	$+25^{\circ}\text{C}$	
		0.72	1.18	$\text{mA}$	$+85^{\circ}\text{C}$	
All devices		0.88	1.45	$\text{mA}$	$-40^{\circ}\text{C}$	
		1	1.45	$\text{mA}$	$+25^{\circ}\text{C}$	
		1.1	1.58	$\text{mA}$	$+85^{\circ}\text{C}$	
All devices		1.2	1.72	$\text{mA}$	$-40^{\circ}\text{C}$	
		1.3	1.72	$\text{mA}$	$+25^{\circ}\text{C}$	
		1.4	1.85	$\text{mA}$	$+85^{\circ}\text{C}$	
All devices		1.3	2.87	$\text{mA}$	$-40^{\circ}\text{C}$	
		1.4	2.87	$\text{mA}$	$+25^{\circ}\text{C}$	
		1.5	2.96	$\text{mA}$	$+85^{\circ}\text{C}$	

- Note 1:** The power-down current in Sleep mode does not depend on the oscillator type. Power-down current is measured with the part in Sleep mode, with all I/O pins in high-impedance state and tied to VDD or VSS and all features that add delta current disabled (such as WDT, Timer1 oscillator, BOR, etc.).
- 2:** The supply current is mainly a function of operating voltage, frequency and mode. Other factors, such as I/O pin loading and switching rate, oscillator type and circuit, internal code execution pattern and temperature, also have an impact on the current consumption.
- The test conditions for all  $I_{DD}$  measurements in active operation mode are:  
 $\text{OSC1}$  = external square wave, from rail-to-rail; all I/O pins tri-stated, pulled to VDD;  
 $\text{MCLR}$  = VDD; WDT enabled/disabled as specified.
- 3:** Standard, low-cost 32 kHz crystals have an operating temperature range of  $-10^{\circ}\text{C}$  to  $+70^{\circ}\text{C}$ . Extended temperature crystals are available at a much higher cost.
- 4:** Voltage regulator is disabled ( $\text{ENVREG} = 0$ , tied to VSS).
- 5:** Voltage regulator is enabled ( $\text{ENVREG} = 1$ , tied to VDD,  $\text{REGSLP} = 1$ ).

## 29.1 DC Characteristics: Power-Down and Supply Current PIC18F87J72 Family (Industrial) (Continued)

PIC18F87J72 Family (Industrial)		Standard Operating Conditions (unless otherwise stated) Operating temperature $-40^{\circ}\text{C} \leq T_A \leq +85^{\circ}\text{C}$ for industrial					
Param. No.	Device	Typ.	Max.	Units	Conditions		
<b>Supply Current (IDD) Cont.</b> <sup>(2,3)</sup>							
	All devices	3	9.4	$\mu\text{A}$	$-40^{\circ}\text{C}$	$V_{DD} = 2.0\text{V}$ , $V_{DDCORE} = 2.0\text{V}^{(4)}$	FOSC = 31 kHz (RC_IDLE mode, internal oscillator source)
		3.3	9.4	$\mu\text{A}$	$+25^{\circ}\text{C}$		
		8.5	17.2	$\mu\text{A}$	$+85^{\circ}\text{C}$		
	All devices	4	10.5	$\mu\text{A}$	$-40^{\circ}\text{C}$	$V_{DD} = 2.5\text{V}$ , $V_{DDCORE} = 2.5\text{V}^{(4)}$	
		4.3	10.5	$\mu\text{A}$	$+25^{\circ}\text{C}$		
		10.3	19.5	$\mu\text{A}$	$+85^{\circ}\text{C}$		
	All devices	34	82	$\mu\text{A}$	$-40^{\circ}\text{C}$	$V_{DD} = 3.3\text{V}^{(5)}$	
		48	82	$\mu\text{A}$	$+25^{\circ}\text{C}$		
		69	105	$\mu\text{A}$	$+85^{\circ}\text{C}$		
All devices	0.33	0.75	$\text{mA}$	$-40^{\circ}\text{C}$	$V_{DD} = 2.0\text{V}$ , $V_{DDCORE} = 2.0\text{V}^{(4)}$	FOSC = 1 MHz (RC_IDLE mode, internal oscillator source)	
	0.37	0.75	$\text{mA}$	$+25^{\circ}\text{C}$			
	0.41	0.84	$\text{mA}$	$+85^{\circ}\text{C}$			
All devices	0.39	0.78	$\text{mA}$	$-40^{\circ}\text{C}$	$V_{DD} = 2.5\text{V}$ , $V_{DDCORE} = 2.5\text{V}^{(4)}$		
	0.42	0.78	$\text{mA}$	$+25^{\circ}\text{C}$			
	0.47	0.91	$\text{mA}$	$+85^{\circ}\text{C}$			
All devices	0.43	0.82	$\text{mA}$	$-40^{\circ}\text{C}$	$V_{DD} = 3.3\text{V}^{(5)}$		
	0.48	0.82	$\text{mA}$	$+25^{\circ}\text{C}$			
	0.54	0.95	$\text{mA}$	$+85^{\circ}\text{C}$			
All devices	0.53	0.98	$\text{mA}$	$-40^{\circ}\text{C}$	$V_{DD} = 2.0\text{V}$ , $V_{DDCORE} = 2.0\text{V}^{(4)}$	FOSC = 4 MHz (RC_IDLE mode, internal oscillator source)	
	0.57	0.98	$\text{mA}$	$+25^{\circ}\text{C}$			
	0.61	1.12	$\text{mA}$	$+85^{\circ}\text{C}$			
All devices	0.63	1.14	$\text{mA}$	$-40^{\circ}\text{C}$	$V_{DD} = 2.5\text{V}$ , $V_{DDCORE} = 2.5\text{V}^{(4)}$		
	0.67	1.14	$\text{mA}$	$+25^{\circ}\text{C}$			
	0.72	1.25	$\text{mA}$	$+85^{\circ}\text{C}$			
All devices	0.7	1.27	$\text{mA}$	$-40^{\circ}\text{C}$	$V_{DD} = 3.3\text{V}^{(5)}$		
	0.76	1.27	$\text{mA}$	$+25^{\circ}\text{C}$			
	0.82	1.45	$\text{mA}$	$+85^{\circ}\text{C}$			

- Note 1:** The power-down current in Sleep mode does not depend on the oscillator type. Power-down current is measured with the part in Sleep mode, with all I/O pins in high-impedance state and tied to VDD or VSS and all features that add delta current disabled (such as WDT, Timer1 oscillator, BOR, etc.).
- Note 2:** The supply current is mainly a function of operating voltage, frequency and mode. Other factors, such as I/O pin loading and switching rate, oscillator type and circuit, internal code execution pattern and temperature, also have an impact on the current consumption.  
The test conditions for all IDD measurements in active operation mode are:  
 $\text{OSC1}$  = external square wave, from rail-to-rail; all I/O pins tri-stated, pulled to VDD;  
 $\text{MCLR}$  = VDD; WDT enabled/disabled as specified.
- Note 3:** Standard, low-cost 32 kHz crystals have an operating temperature range of  $-10^{\circ}\text{C}$  to  $+70^{\circ}\text{C}$ . Extended temperature crystals are available at a much higher cost.
- Note 4:** Voltage regulator is disabled (ENVREG = 0, tied to VSS).
- Note 5:** Voltage regulator is enabled (ENVREG = 1, tied to VDD, REGSLP = 1).

# PIC18F87J72

## 29.1 DC Characteristics: Power-Down and Supply Current PIC18F87J72 Family (Industrial) (Continued)

PIC18F87J72 Family (Industrial)		Standard Operating Conditions (unless otherwise stated) Operating temperature $-40^{\circ}\text{C} \leq T_A \leq +85^{\circ}\text{C}$ for industrial				
Param. No.	Device	Typ.	Max.	Units	Conditions	
<b>Supply Current (I<sub>DD</sub>) Cont.</b> <sup>(2,3)</sup>						
All devices		0.17	0.35	mA	$-40^{\circ}\text{C}$	$V_{DD} = 2.0\text{V}$ , $V_{DDCORE} = 2.0\text{V}^{(4)}$  $V_{DD} = 2.5\text{V}$ , $V_{DDCORE} = 2.5\text{V}^{(4)}$  $V_{DD} = 3.3\text{V}^{(5)}$  $V_{DD} = 2.0\text{V}$ , $V_{DDCORE} = 2.0\text{V}^{(4)}$  $V_{DD} = 2.5\text{V}$ , $V_{DDCORE} = 2.5\text{V}^{(4)}$  $V_{DD} = 3.3\text{V}^{(5)}$  $V_{DD} = 2.5\text{V}$ , $V_{DDCORE} = 2.5\text{V}^{(4)}$  $V_{DD} = 3.3\text{V}^{(5)}$
		0.18	0.35	mA	$+25^{\circ}\text{C}$	
		0.20	0.42	mA	$+85^{\circ}\text{C}$	
All devices		0.29	0.52	mA	$-40^{\circ}\text{C}$	
		0.31	0.52	mA	$+25^{\circ}\text{C}$	
		0.34	0.61	mA	$+85^{\circ}\text{C}$	
All devices		0.59	1.1	mA	$-40^{\circ}\text{C}$	
		0.44	0.85	mA	$+25^{\circ}\text{C}$	
		0.42	0.85	mA	$+85^{\circ}\text{C}$	
All devices		0.70	1.25	mA	$-40^{\circ}\text{C}$	
		0.75	1.25	mA	$+25^{\circ}\text{C}$	
		0.79	1.36	mA	$+85^{\circ}\text{C}$	
All devices		1.10	1.7	mA	$-40^{\circ}\text{C}$	
		1.10	1.7	mA	$+25^{\circ}\text{C}$	
		1.12	1.82	mA	$+85^{\circ}\text{C}$	
All devices		1.55	1.95	mA	$-40^{\circ}\text{C}$	
		1.47	1.89	mA	$+25^{\circ}\text{C}$	
		1.54	1.92	mA	$+85^{\circ}\text{C}$	
All devices		9.9	14.8	mA	$-40^{\circ}\text{C}$	
		9.5	14.8	mA	$+25^{\circ}\text{C}$	
		10.1	15.2	mA	$+85^{\circ}\text{C}$	
All devices		13.3	23.2	mA	$-40^{\circ}\text{C}$	
		12.2	22.7	mA	$+25^{\circ}\text{C}$	
		12.1	22.7	mA	$+85^{\circ}\text{C}$	

- Note 1:** The power-down current in Sleep mode does not depend on the oscillator type. Power-down current is measured with the part in Sleep mode, with all I/O pins in high-impedance state and tied to V<sub>DD</sub> or V<sub>SS</sub> and all features that add delta current disabled (such as WDT, Timer1 oscillator, BOR, etc.).
- 2:** The supply current is mainly a function of operating voltage, frequency and mode. Other factors, such as I/O pin loading and switching rate, oscillator type and circuit, internal code execution pattern and temperature, also have an impact on the current consumption.  
The test conditions for all I<sub>DD</sub> measurements in active operation mode are:  
 OSC1 = external square wave, from rail-to-rail; all I/O pins tri-stated, pulled to V<sub>DD</sub>;  
 MCLR = V<sub>DD</sub>; WDT enabled/disabled as specified.
- 3:** Standard, low-cost 32 kHz crystals have an operating temperature range of  $-10^{\circ}\text{C}$  to  $+70^{\circ}\text{C}$ . Extended temperature crystals are available at a much higher cost.
- 4:** Voltage regulator is disabled (ENVREG = 0, tied to V<sub>SS</sub>).
- 5:** Voltage regulator is enabled (ENVREG = 1, tied to V<sub>DD</sub>, REGSLP = 1).

## 29.1 DC Characteristics: Power-Down and Supply Current PIC18F87J72 Family (Industrial) (Continued)

PIC18F87J72 Family (Industrial)		Standard Operating Conditions (unless otherwise stated) Operating temperature $-40^{\circ}\text{C} \leq T_A \leq +85^{\circ}\text{C}$ for industrial				
Param. No.	Device	Typ.	Max.	Units	Conditions	
<b>Supply Current (I<sub>DD</sub>) Cont.</b> <sup>(2,3)</sup>						
	All devices	4.5	5.2	mA	-40°C	V <sub>DD</sub> = 2.5V, V <sub>DDCORE</sub> = 2.5V <sup>(4)</sup>  F <sub>OSC</sub> = 4 MHz, 16 MHz internal ( <b>PRI_RUN HSPLL</b> mode)
		4.4	5.2	mA	+25°C	
		4.5	5.2	mA	+85°C	
	All devices	5.7	6.7	mA	-40°C	V <sub>DD</sub> = 3.3V <sup>(5)</sup>  F <sub>OSC</sub> = 4 MHz, 16 MHz internal ( <b>PRI_RUN HSPLL</b> mode)
		5.5	6.3	mA	+25°C	
		5.3	6.3	mA	+85°C	
	All devices	10.8	13.5	mA	-40°C	V <sub>DD</sub> = 2.5V, V <sub>DDCORE</sub> = 2.5V <sup>(4)</sup>  F <sub>OSC</sub> = 10 MHz, 40 MHz internal ( <b>PRI_RUN HSPLL</b> mode)
		10.8	13.5	mA	+25°C	
		9.9	13.0	mA	+85°C	
	All devices	13.4	24.1	mA	-40°C	V <sub>DD</sub> = 3.3V <sup>(5)</sup>  F <sub>OSC</sub> = 10 MHz, 40 MHz internal ( <b>PRI_RUN HSPLL</b> mode)
		12.3	20.2	mA	+25°C	
		11.2	19.5	mA	+85°C	

- Note 1:** The power-down current in Sleep mode does not depend on the oscillator type. Power-down current is measured with the part in Sleep mode, with all I/O pins in high-impedance state and tied to V<sub>DD</sub> or V<sub>SS</sub> and all features that add delta current disabled (such as WDT, Timer1 oscillator, BOR, etc.).
- 2:** The supply current is mainly a function of operating voltage, frequency and mode. Other factors, such as I/O pin loading and switching rate, oscillator type and circuit, internal code execution pattern and temperature, also have an impact on the current consumption.  
The test conditions for all I<sub>DD</sub> measurements in active operation mode are:  
OSC1 = external square wave, from rail-to-rail; all I/O pins tri-stated, pulled to V<sub>DD</sub>;  
MCLR = V<sub>DD</sub>; WDT enabled/disabled as specified.
- 3:** Standard, low-cost 32 kHz crystals have an operating temperature range of -10°C to +70°C. Extended temperature crystals are available at a much higher cost.
- 4:** Voltage regulator is disabled (ENVREG = 0, tied to V<sub>SS</sub>).
- 5:** Voltage regulator is enabled (ENVREG = 1, tied to V<sub>DD</sub>, REGSLP = 1).

# PIC18F87J72

## 29.1 DC Characteristics: Power-Down and Supply Current PIC18F87J72 Family (Industrial) (Continued)

PIC18F87J72 Family (Industrial)		Standard Operating Conditions (unless otherwise stated) Operating temperature $-40^{\circ}\text{C} \leq T_A \leq +85^{\circ}\text{C}$ for industrial					
Param. No.	Device	Typ.	Max.	Units	Conditions		
<b>Supply Current (I<sub>DD</sub>) Cont.</b> <sup>(2,3)</sup>							
All devices		0.10	0.26	mA	-40°C	V <sub>DD</sub> = 2.0V, V <sub>DDCORE</sub> = 2.0V <sup>(4)</sup>	FOSC = 1 MHz ( <b>PRI_IDLE</b> mode, EC oscillator)
		0.07	0.18	mA	+25°C		
		0.09	0.22	mA	+85°C		
All devices		0.25	0.48	mA	-40°C	V <sub>DD</sub> = 2.5V, V <sub>DDCORE</sub> = 2.5V <sup>(4)</sup>	
		0.13	0.30	mA	+25°C		
		0.10	0.26	mA	+85°C		
All devices		0.45	0.68	mA	-40°C	V <sub>DD</sub> = 3.3V <sup>(5)</sup>	
		0.26	0.45	mA	+25°C		
		0.30	0.54	mA	+85°C		
All devices		0.36	0.60	mA	-40°C	V <sub>DD</sub> = 2.0V, V <sub>DDCORE</sub> = 2.0V <sup>(4)</sup>	FOSC = 4 MHz ( <b>PRI_IDLE</b> mode, EC oscillator)
		0.33	0.56	mA	+25°C		
		0.35	0.56	mA	+85°C		
All devices		0.52	0.81	mA	-40°C	V <sub>DD</sub> = 2.5V, V <sub>DDCORE</sub> = 2.5V <sup>(4)</sup>	
		0.45	0.70	mA	+25°C		
		0.46	0.70	mA	+85°C		
All devices		0.80	1.15	mA	-40°C	V <sub>DD</sub> = 3.3V <sup>(5)</sup>	
		0.66	0.98	mA	+25°C		
		0.65	0.98	mA	+85°C		
All devices		5.2	6.5	mA	-40°C	V <sub>DD</sub> = 2.5V, V <sub>DDCORE</sub> = 2.5V <sup>(4)</sup>	FOSC = 48 MHz ( <b>PRI_IDLE</b> mode, EC oscillator)
		4.9	5.9	mA	+25°C		
		3.4	4.5	mA	+85°C		
All devices		6.2	12.4	mA	-40°C	V <sub>DD</sub> = 3.3V <sup>(5)</sup>	
		5.9	11.5	mA	+25°C		
		5.8	11.5	mA	+85°C		

- Note 1:** The power-down current in Sleep mode does not depend on the oscillator type. Power-down current is measured with the part in Sleep mode, with all I/O pins in high-impedance state and tied to V<sub>DD</sub> or V<sub>SS</sub> and all features that add delta current disabled (such as WDT, Timer1 oscillator, BOR, etc.).
- 2:** The supply current is mainly a function of operating voltage, frequency and mode. Other factors, such as I/O pin loading and switching rate, oscillator type and circuit, internal code execution pattern and temperature, also have an impact on the current consumption.  
The test conditions for all I<sub>DD</sub> measurements in active operation mode are:  
OSC1 = external square wave, from rail-to-rail; all I/O pins tri-stated, pulled to V<sub>DD</sub>;  
MCLR = V<sub>DD</sub>; WDT enabled/disabled as specified.
- 3:** Standard, low-cost 32 kHz crystals have an operating temperature range of -10°C to +70°C. Extended temperature crystals are available at a much higher cost.
- 4:** Voltage regulator is disabled (ENVREG = 0, tied to V<sub>SS</sub>).
- 5:** Voltage regulator is enabled (ENVREG = 1, tied to V<sub>DD</sub>, REGSLP = 1).



## 29.1 DC Characteristics: Power-Down and Supply Current PIC18F87J72 Family (Industrial) (Continued)

PIC18F87J72 Family (Industrial)		Standard Operating Conditions (unless otherwise stated) Operating temperature $-40^{\circ}\text{C} \leq T_A \leq +85^{\circ}\text{C}$ for industrial						
Param. No.	Device	Typ.	Max.	Units	Conditions			
<b>Supply Current (I<sub>DD</sub>) Cont.<sup>(2,3)</sup></b>								
All devices	All devices	18	35	$\mu\text{A}$	$-40^{\circ}\text{C}$	$V_{\text{DD}} = 2.0\text{V}$ , $V_{\text{DDCORE}} = 2.0\text{V}^{(4)}$  $V_{\text{DD}} = 2.5\text{V}$ , $V_{\text{DDCORE}} = 2.5\text{V}^{(4)}$  $V_{\text{DD}} = 3.3\text{V}^{(5)}$		
		19	35	$\mu\text{A}$	$+25^{\circ}\text{C}$			
		28	49	$\mu\text{A}$	$+85^{\circ}\text{C}$			
	All devices	20	45	$\mu\text{A}$	$-40^{\circ}\text{C}$		$F_{\text{OSC}} = 32\text{ kHz}^{(3)}$ <b>(SEC_RUN mode,</b> <b>Timer1 as clock)</b>	
		21	45	$\mu\text{A}$	$+25^{\circ}\text{C}$			
		32	61	$\mu\text{A}$	$+85^{\circ}\text{C}$			
	All devices	0.06	0.11	$\text{mA}$	$-40^{\circ}\text{C}$			$V_{\text{DD}} = 3.3\text{V}^{(5)}$
		0.07	0.11	$\text{mA}$	$+25^{\circ}\text{C}$			
		0.09	0.15	$\text{mA}$	$+85^{\circ}\text{C}$			
All devices	14	28	$\mu\text{A}$	$-40^{\circ}\text{C}$	$V_{\text{DD}} = 2.0\text{V}$ , $V_{\text{DDCORE}} = 2.0\text{V}^{(4)}$  $V_{\text{DD}} = 2.5\text{V}$ , $V_{\text{DDCORE}} = 2.5\text{V}^{(4)}$  $V_{\text{DD}} = 3.3\text{V}^{(5)}$			
	15	28	$\mu\text{A}$	$+25^{\circ}\text{C}$				
	24	43	$\mu\text{A}$	$+85^{\circ}\text{C}$				
All devices	15	31	$\mu\text{A}$	$-40^{\circ}\text{C}$		$F_{\text{OSC}} = 32\text{ kHz}^{(3)}$ <b>(SEC_IDLE mode,</b> <b>Timer1 as clock)</b>		
	16	31	$\mu\text{A}$	$+25^{\circ}\text{C}$				
	27	50	$\mu\text{A}$	$+85^{\circ}\text{C}$				
All devices	0.05	0.10	$\text{mA}$	$-40^{\circ}\text{C}$			$V_{\text{DD}} = 3.3\text{V}^{(5)}$	
	0.06	0.10	$\text{mA}$	$+25^{\circ}\text{C}$				
	0.08	0.14	$\text{mA}$	$+85^{\circ}\text{C}$				

- Note 1:** The power-down current in Sleep mode does not depend on the oscillator type. Power-down current is measured with the part in Sleep mode, with all I/O pins in high-impedance state and tied to  $V_{\text{DD}}$  or  $V_{\text{SS}}$  and all features that add delta current disabled (such as WDT, Timer1 oscillator, BOR, etc.).
- 2:** The supply current is mainly a function of operating voltage, frequency and mode. Other factors, such as I/O pin loading and switching rate, oscillator type and circuit, internal code execution pattern and temperature, also have an impact on the current consumption.  
The test conditions for all  $I_{\text{DD}}$  measurements in active operation mode are:  
 $\text{OSC1} = \text{external square wave, from rail-to-rail; all I/O pins tri-stated, pulled to } V_{\text{DD}};$   
 $\text{MCLR} = V_{\text{DD}};$  WDT enabled/disabled as specified.
- 3:** Standard, low-cost 32 kHz crystals have an operating temperature range of  $-10^{\circ}\text{C}$  to  $+70^{\circ}\text{C}$ . Extended temperature crystals are available at a much higher cost.
- 4:** Voltage regulator is disabled ( $\text{ENVREG} = 0$ , tied to  $V_{\text{SS}}$ ).
- 5:** Voltage regulator is enabled ( $\text{ENVREG} = 1$ , tied to  $V_{\text{DD}}$ ,  $\text{REGSLP} = 1$ ).

# PIC18F87J72

## 29.1 DC Characteristics: Power-Down and Supply Current PIC18F87J72 Family (Industrial) (Continued)

PIC18F87J72 Family (Industrial)		Standard Operating Conditions (unless otherwise stated) Operating temperature $-40^{\circ}\text{C} \leq T_A \leq +85^{\circ}\text{C}$ for industrial							
Param. No.	Device	Typ.	Max.	Units	Conditions				
D022	<b>Module Differential Currents (<math>\Delta I_{WDT}</math>, <math>\Delta I_{OSCB}</math>, <math>\Delta I_{AD}</math>)</b> <b>Watchdog Timer</b>	2.1	7.0	$\mu\text{A}$	$-40^{\circ}\text{C}$	$V_{DD} = 2.0\text{V}$ , $V_{DDCORE} = 2.0\text{V}^{(4)}$			
		2.2	7.0	$\mu\text{A}$	$+25^{\circ}\text{C}$				
		4.3	9.5	$\mu\text{A}$	$+85^{\circ}\text{C}$				
				3.0	8.0	$\mu\text{A}$	$-40^{\circ}\text{C}$	$V_{DD} = 2.5\text{V}$ , $V_{DDCORE} = 2.5\text{V}^{(4)}$	
				3.1	8.0	$\mu\text{A}$	$+25^{\circ}\text{C}$		
				5.5	10.4	$\mu\text{A}$	$+85^{\circ}\text{C}$		
				5.9	12.1	$\mu\text{A}$	$-40^{\circ}\text{C}$		
				6.2	12.1	$\mu\text{A}$	$+25^{\circ}\text{C}$	$V_{DD} = 3.3\text{V}$	
				6.9	13.6	$\mu\text{A}$	$+85^{\circ}\text{C}$		
D024 ( $\Delta I_{LCD}$ )	<b>LCD Module</b>	2 <sup>(6,7)</sup>	5	$\mu\text{A}$	$+25^{\circ}\text{C}$	$V_{DD} = 2.0\text{V}$	Resistive Ladder CPEN = 0; CKSEL<1:0> = 00; CS<1:0> = 10; LP<3:0> = 0100		
		2.7 <sup>(6,7)</sup>	5	$\mu\text{A}$	$+25^{\circ}\text{C}$	$V_{DD} = 2.5\text{V}$			
		3.5 <sup>(6,7)</sup>	7	$\mu\text{A}$	$+25^{\circ}\text{C}$	$V_{DD} = 3.0\text{V}$			
				16 <sup>(7)</sup>	25	$\mu\text{A}$	$+25^{\circ}\text{C}$	$V_{DD} = 2.0\text{V}$	Charge Pump BIAS<2:0> = 111; CPEN = 1; CKSEL<1:0> = 11; CS<1:0> = 10
				17 <sup>(7)</sup>	25	$\mu\text{A}$	$+25^{\circ}\text{C}$	$V_{DD} = 2.5\text{V}$	
				24 <sup>(7)</sup>	40	$\mu\text{A}$	$+25^{\circ}\text{C}$	$V_{DD} = 3.0\text{V}$	
D025 ( $\Delta I_{OSCB}$ )	<b>RTCC + Timer1 Osc. with 32 kHz Crystal<sup>(6)</sup></b>	0.9	4.0	$\mu\text{A}$	$-10^{\circ}\text{C}$	$V_{DD} = 2.0\text{V}$ , $V_{DDCORE} = 2.0\text{V}^{(4)}$	32 kHz on Timer1 <sup>(3)</sup>		
		1.0	4.5	$\mu\text{A}$	$+25^{\circ}\text{C}$				
		1.1	4.5	$\mu\text{A}$	$+85^{\circ}\text{C}$				
				1.1	4.5	$\mu\text{A}$	$-10^{\circ}\text{C}$	$V_{DD} = 2.5\text{V}$ , $V_{DDCORE} = 2.5\text{V}^{(4)}$	32 kHz on Timer1 <sup>(3)</sup>
				1.2	5.0	$\mu\text{A}$	$+25^{\circ}\text{C}$		
				1.2	5.0	$\mu\text{A}$	$+85^{\circ}\text{C}$		
				1.6	6.5	$\mu\text{A}$	$-10^{\circ}\text{C}$		
				1.6	6.5	$\mu\text{A}$	$+25^{\circ}\text{C}$	$V_{DD} = 3.3\text{V}$	32 kHz on Timer1 <sup>(3)</sup>
2.1	8.0			$\mu\text{A}$	$+85^{\circ}\text{C}$				
D026 ( $\Delta I_{AD}$ )	<b>A/D Converter</b>	3.0	10.0	$\mu\text{A}$	$-40^{\circ}\text{C}$ to $+85^{\circ}\text{C}$	$V_{DD} = 2.0\text{V}$ , $V_{DDCORE} = 2.0\text{V}^{(4)}$	A/D on, not converting		
		3.0	10.0	$\mu\text{A}$	$-40^{\circ}\text{C}$ to $+85^{\circ}\text{C}$			$V_{DD} = 2.5\text{V}$ ,	

- Note 1:** The power-down current in Sleep mode does not depend on the oscillator type. Power-down current is measured with the part in Sleep mode, with all I/O pins in high-impedance state and tied to  $V_{DD}$  or  $V_{SS}$  and all features that add delta current disabled (such as WDT, Timer1 oscillator, BOR, etc.).
- 2:** The supply current is mainly a function of operating voltage, frequency and mode. Other factors, such as I/O pin loading and switching rate, oscillator type and circuit, internal code execution pattern and temperature, also have an impact on the current consumption.  
The test conditions for all  $I_{DD}$  measurements in active operation mode are:  
OSC1 = external square wave, from rail-to-rail; all I/O pins tri-stated, pulled to  $V_{DD}$ ;  
MCLR =  $V_{DD}$ ; WDT enabled/disabled as specified.
- 3:** Standard, low-cost 32 kHz crystals have an operating temperature range of  $-10^{\circ}\text{C}$  to  $+70^{\circ}\text{C}$ . Extended temperature crystals are available at a much higher cost.
- 4:** Voltage regulator is disabled (ENVREG = 0, tied to  $V_{SS}$ ).
- 5:** Voltage regulator is enabled (ENVREG = 1, tied to  $V_{DD}$ , REGSLP = 1).

## 29.2 DC Characteristics: PIC18F87J72 Family (Industrial)

DC CHARACTERISTICS			Standard Operating Conditions (unless otherwise stated) Operating temperature $-40^{\circ}\text{C} \leq T_A \leq +85^{\circ}\text{C}$ for industrial			
Param. No.	Symbol	Characteristic	Min.	Max.	Units	Conditions
	$V_{IL}$	<b>Input Low Voltage</b>				
D030		All I/O Ports: with TTL Buffer	$V_{SS}$	$0.15 V_{DD}$	V	$V_{DD} < 3.3\text{V}$
D030A			—	0.8	V	$3.3\text{V} \leq V_{DD} \leq 3.6\text{V}$
D031		with Schmitt Trigger Buffer	$V_{SS}$	$0.2 V_{DD}$	V	
D031A		RC3 and RC4 only	$V_{SS}$	$0.3 V_{DD}$	V	I <sup>2</sup> C enabled
D031B			$V_{SS}$	0.8	V	SMBus
D032		$\overline{\text{MCLR}}$	$V_{SS}$	$0.2 V_{DD}$	V	
D033		OSC1	$V_{SS}$	$0.3 V_{DD}$	V	HS, HSPLL modes
D033A		OSC1	$V_{SS}$	$0.2 V_{DD}$	V	EC, ECPLL modes
D034		T13CKI	$V_{SS}$	0.3	V	
	$V_{IH}$	<b>Input High Voltage</b>				
D040		I/O Ports (not 5.5V tolerant): with TTL Buffer	$0.25 V_{DD} + 0.8\text{V}$	$V_{DD}$	V	$V_{DD} < 3.3\text{V}$
D040A			2.0	$V_{DD}$		$3.3\text{V} \leq V_{DD} \leq 3.6\text{V}$
D041		with Schmitt Trigger Buffer	$0.8 V_{DD}$	$V_{DD}$	V	
D041A		RC3 and RC4 only	$0.7 V_{DD}$	$V_{DD}$	V	I <sup>2</sup> C enabled
D041B			2.1	$V_{DD}$	V	SMBus
		I/O Ports (5.5V tolerant): with TTL Buffer	$0.25 V_{DD} + 0.8\text{V}$	5.5	V	$V_{DD} < 3.3\text{V}$
			2.0	5.5	V	$3.3\text{V} \leq V_{DD} \leq 3.6\text{V}$
		with Schmitt Trigger Buffer	$0.8 V_{DD}$	5.5	V	
D042		$\overline{\text{MCLR}}$	$0.8 V_{DD}$	$V_{DD}$	V	
D043		OSC1	$0.7 V_{DD}$	$V_{DD}$	V	HS, HSPLL modes
D043A		OSC1	$0.8 V_{DD}$	$V_{DD}$	V	EC, ECPLL modes
D044		T13CKI	1.6	$V_{DD}$	V	
	$I_{IL}$	<b>Input Leakage Current<sup>(1)</sup></b>				
D060		I/O Ports with Analog Functions	—	200	nA	$V_{SS} \leq V_{PIN} \leq V_{DD}$ , Pin at high-impedance
		Digital Only I/O Ports	—	200	nA	$V_{SS} \leq V_{PIN} \leq 5.5\text{V}$ , Pin at high-impedance
D061		$\overline{\text{MCLR}}$	—	$\pm 1$	$\mu\text{A}$	$V_{SS} \leq V_{PIN} \leq V_{DD}$
D063		OSC1	—	$\pm 1$	$\mu\text{A}$	$V_{SS} \leq V_{PIN} \leq V_{DD}$
	IPU IPURB	<b>Weak Pull-up Current</b>				
D070		PORTB Weak Pull-up Current	80	400	$\mu\text{A}$	$V_{DD} = 3.3\text{V}$ , $V_{PIN} = V_{SS}$

**Note 1:** Negative current is defined as current sourced by the pin.

# PIC18F87J72

## 29.2 DC Characteristics: PIC18F87J72 Family (Industrial) (Continued)

DC CHARACTERISTICS			Standard Operating Conditions (unless otherwise stated) Operating temperature $-40^{\circ}\text{C} \leq T_A \leq +85^{\circ}\text{C}$ for industrial			
Param. No.	Symbol	Characteristic	Min.	Max.	Units	Conditions
D080	VOL	<b>Output Low Voltage</b>				
		I/O Ports: PORTA, PORTF, PORTG,	—	0.4	V	$I_{OL} = 2 \text{ mA}$ , $V_{DD} = 3.3\text{V}$ , $-40^{\circ}\text{C}$ to $+85^{\circ}\text{C}$
		PORTD, PORTE	—	0.4	V	$I_{OL} = 3.4 \text{ mA}$ , $V_{DD} = 3.3\text{V}$ , $-40^{\circ}\text{C}$ to $+85^{\circ}\text{C}$
D083	VOL	PORTB, PORTC	—	0.4	V	$I_{OL} = 3.4 \text{ mA}$ , $V_{DD} = 3.3\text{V}$ , $-40^{\circ}\text{C}$ to $+85^{\circ}\text{C}$
		OSC2/CLKO (EC, ECPLL modes)	—	0.4	V	$I_{OL} = 1.6 \text{ mA}$ , $V_{DD} = 3.3\text{V}$ , $-40^{\circ}\text{C}$ to $+85^{\circ}\text{C}$
D090	VOH	<b>Output High Voltage<sup>(1)</sup></b>				
		I/O Ports: PORTA, PORTF, PORTG	2.4	—	V	$I_{OH} = -2 \text{ mA}$ , $V_{DD} = 3.3\text{V}$ , $-40^{\circ}\text{C}$ to $+85^{\circ}\text{C}$
		PORTD, PORTE	2.4	—	V	$I_{OH} = -2 \text{ mA}$ , $V_{DD} = 3.3\text{V}$ , $-40^{\circ}\text{C}$ to $+85^{\circ}\text{C}$
D092	VOH	PORTB, PORTC	2.4	—	V	$I_{OH} = -2 \text{ mA}$ , $V_{DD} = 3.3\text{V}$ , $-40^{\circ}\text{C}$ to $+85^{\circ}\text{C}$
		OSC2/CLKO (INTOSC, EC, ECPLL modes)	2.4	—	V	$I_{OH} = -1 \text{ mA}$ , $V_{DD} = 3.3\text{V}$ , $-40^{\circ}\text{C}$ to $+85^{\circ}\text{C}$
D100 <sup>(4)</sup>	COSC2	<b>Capacitive Loading Specs on Output Pins</b>				
		OSC2 Pin	—	15	pF	In HS mode when external clock is used to drive OSC1
		All I/O Pins and OSC2	—	50	pF	To meet the AC Timing Specifications
D102	CB	SCL, SDA	—	400	pF	I <sup>2</sup> C Specification

**Note 1:** Negative current is defined as current sourced by the pin.

## 29.3 DC Characteristics: CTMU Current Source Specifications

DC CHARACTERISTICS			Standard Operating Conditions: 2.0V to 3.6V (unless otherwise stated) Operating temperature $-40^{\circ}\text{C} \leq T_A \leq +85^{\circ}\text{C}$ for Industrial				
Param. No.	Sym.	Characteristic	Min.	Typ. <sup>(1)</sup>	Max.	Units	Conditions
	IOUT1	CTMU Current Source, Base Range	—	550	—	nA	CTMUICON<1:0> = 01
	IOUT2	CTMU Current Source, 10x Range	—	5.5	—	$\mu\text{A}$	CTMUICON<1:0> = 10
	IOUT3	CTMU Current Source, 100x Range	—	55	—	$\mu\text{A}$	CTMUICON<1:0> = 11

**Note 1:** Nominal value at center point of current trim range (CTMUICON<7:2> = 000000).

**TABLE 29-1: MEMORY PROGRAMMING REQUIREMENTS**

DC CHARACTERISTICS			Standard Operating Conditions (unless otherwise stated) Operating temperature $-40^{\circ}\text{C} \leq T_A \leq +85^{\circ}\text{C}$ for industrial					
Param. No.	Sym.	Characteristic	Min.	Typ†	Max.	Units	Conditions	
<b>Program Flash Memory</b>								
D130	EP	Cell Endurance	10K	—	—	E/W	$-40^{\circ}\text{C}$ to $+85^{\circ}\text{C}$	
D131	VPR	VDD for Read	V <sub>MIN</sub>	—	3.6	V	V <sub>MIN</sub> = Minimum operating voltage	
D132B	VPEW	Voltage for Self-Timed Erase or Write operations	VDD	2.35	—	3.6	V	ENVREG tied to VDD ENVREG tied to VSS
			VDDCORE	2.25	—	2.7	V	
D133A	TIW	Self-Timed Write Cycle Time	—	2.8	—	ms		
D133B	TIE	Self-Timed Block Erased Cycle Time	—	33	—	ms		
D134	TRETD	Characteristic Retention	20	—	—	Year	Provided no other specifications are violated	
D135	IDDP	Supply Current during Programming	—	3	14	mA		
D140	TWE	Writes per Erase Cycle	—	—	1		For each physical address	

† Data in "Typ" column is at 3.3V, 25°C unless otherwise stated. These parameters are for design guidance only and are not tested.

**TABLE 29-2: COMPARATOR SPECIFICATIONS**

Operating Conditions: $3.0\text{V} \leq V_{DD} \leq 3.6\text{V}$ , $-40^{\circ}\text{C} \leq T_A \leq +85^{\circ}\text{C}$ (unless otherwise stated)							
Param. No.	Sym.	Characteristics	Min.	Typ.	Max.	Units	Comments
D300	V <sub>IOFF</sub>	Input Offset Voltage	—	$\pm 5.0$	$\pm 25$	mV	
D301	V <sub>ICM</sub>	Input Common-Mode Voltage	0	—	$A_{VDD} - 1.5$	V	
D302	CMRR	Common-Mode Rejection Ratio	55	—	—	dB	
D303	T <sub>RESP</sub>	Response Time <sup>(1)</sup>	—	150	400	ns	
D304	T <sub>MC2OV</sub>	Comparator Mode Change to Output Valid*	—	—	10	$\mu\text{s}$	

**Note 1:** Response time measured with one comparator input at  $(A_{VDD} - 1.5)/2$ , while the other input transitions from VSS to VDD.

# PIC18F87J72

**TABLE 29-3: VOLTAGE REFERENCE SPECIFICATIONS**

Operating Conditions: $3.0V \leq V_{DD} \leq 3.6V$ , $-40^{\circ}C \leq T_A \leq +85^{\circ}C$ (unless otherwise stated)							
Param. No.	Sym.	Characteristics	Min.	Typ.	Max.	Units	Comments
D310	VRES	Resolution	$V_{DD}/24$	—	$V_{DD}/32$	LSb	
D311	VRAA	Absolute Accuracy	—	—	1/2	LSb	
D312	VRUR	Unit Resistor Value (R)	—	2k	—	$\Omega$	
310	TSET	Settling Time <sup>(1)</sup>	—	—	10	$\mu$ s	

**Note 1:** Settling time measured while CVRR = 1 and CVR<3:0> transitions from '0000' to '1111'.

**TABLE 29-4: INTERNAL VOLTAGE REGULATOR SPECIFICATIONS**

Operating Conditions: $-40^{\circ}C \leq T_A \leq +85^{\circ}C$ (unless otherwise stated)							
Param. No.	Sym.	Characteristics	Min.	Typ.	Max.	Units	Comments
	VRGOUT	Regulator Output Voltage*	—	2.5	—	V	
	CEFC	External Filter Capacitor Value*	4.7	10	—	$\mu$ F	Capacitor must be low-ESR, a low series resistance ( $< 5\Omega$ )

**TABLE 29-5: INTERNAL LCD VOLTAGE REGULATOR SPECIFICATIONS**

Operating Conditions: $2.0V \leq V_{DD} \leq 3.6V$ , $-40^{\circ}C \leq T_A \leq +85^{\circ}C$ (unless otherwise stated)							
Param. No.	Sym.	Characteristics	Min.	Typ.	Max.	Units	Comments
	CFLY	Fly Back Capacitor	0.47	4.7	—	$\mu$ F	Capacitor must be low-ESR
	VBIAS	VPK-PK between LCDBIAS0 & LCDBIAS3	—	3.40	3.6	V	BIAS<2:0> = 111
			—	3.27	—	V	BIAS<2:0> = 110
			—	3.14	—	V	BIAS<2:0> = 101
			—	3.01	—	V	BIAS<2:0> = 100
			—	2.88	—	V	BIAS<2:0> = 011
			—	2.75	—	V	BIAS<2:0> = 010
			—	2.62	—	V	BIAS<2:0> = 001
			—	2.49	—	V	BIAS<2:0> = 000

## 29.4 AC (Timing) Characteristics

### 29.4.1 TIMING PARAMETER SYMBOLOGY

The timing parameter symbols have been created following one of the following formats:

- |             |           |  |
|-------------|-----------|--|
| 1. TppS2ppS | 3. TCC:ST | (I <sup>2</sup> C specifications only) |
| 2. TppS     | 4. Ts     | (I <sup>2</sup> C specifications only) |

T		T	
F	Frequency	T	Time

Lowercase letters (pp) and their meanings:

pp			
cc	CCP1	osc	OSC1
ck	CLKO	rd	$\overline{RD}$
cs	$\overline{CS}$	rw	$\overline{RD}$ or $\overline{WR}$
di	SDI	sc	SCK
do	SDO	ss	$\overline{SS}$
dt	Data in	t0	T0CKI
io	I/O port	t1	T13CKI
mc	$\overline{MCLR}$	wr	$\overline{WR}$

Uppercase letters and their meanings:

S			
F	Fall	P	Period
H	High	R	Rise
I	Invalid (High-impedance)	V	Valid
L	Low	Z	High-impedance
I <sup>2</sup> C only			
AA	output access	High	High
BUF	Bus free	Low	Low

TCC:ST (I<sup>2</sup>C specifications only)

CC			
HD	Hold	SU	Setup
ST			
DAT	DATA input hold	STO	Stop condition
STA	Start condition		

# PIC18F87J72

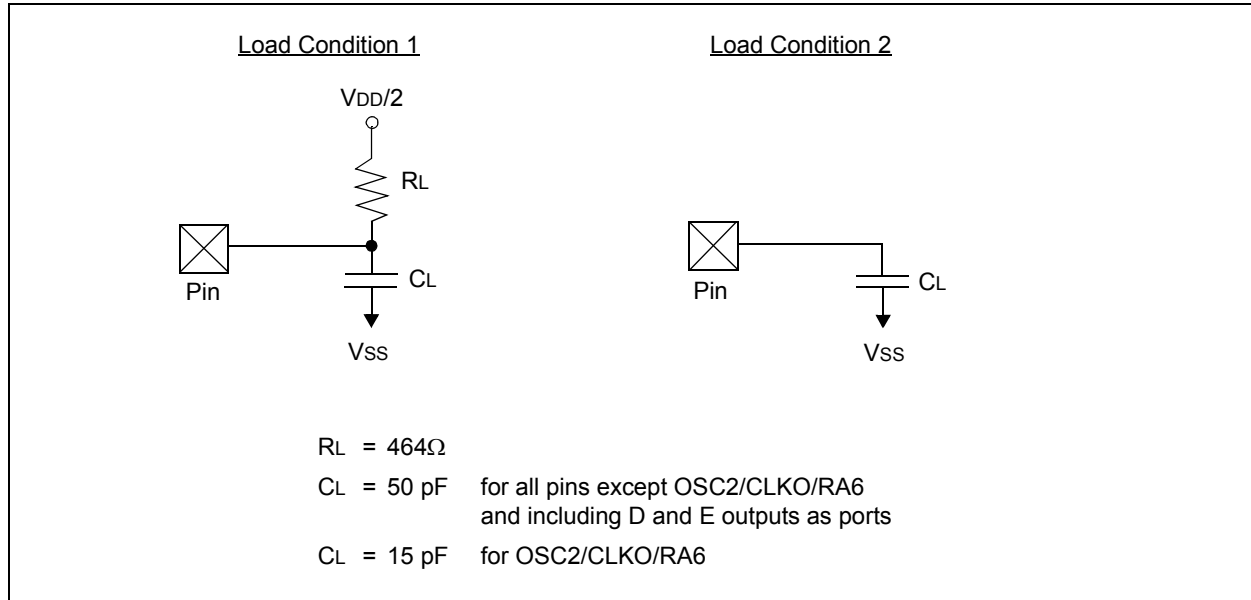
## 29.4.2 TIMING CONDITIONS

The temperature and voltages specified in [Table 29-6](#) apply to all timing specifications unless otherwise noted. [Figure 29-3](#) specifies the load conditions for the timing specifications.

**TABLE 29-6: TEMPERATURE AND VOLTAGE SPECIFICATIONS – AC**

AC CHARACTERISTICS	Standard Operating Conditions (unless otherwise stated)
	Operating temperature $-40^{\circ}\text{C} \leq T_A \leq +85^{\circ}\text{C}$ for industrial
	Operating voltage $V_{DD}$ range as described in <a href="#">Section 29.1</a> and <a href="#">Section 29.2</a> .

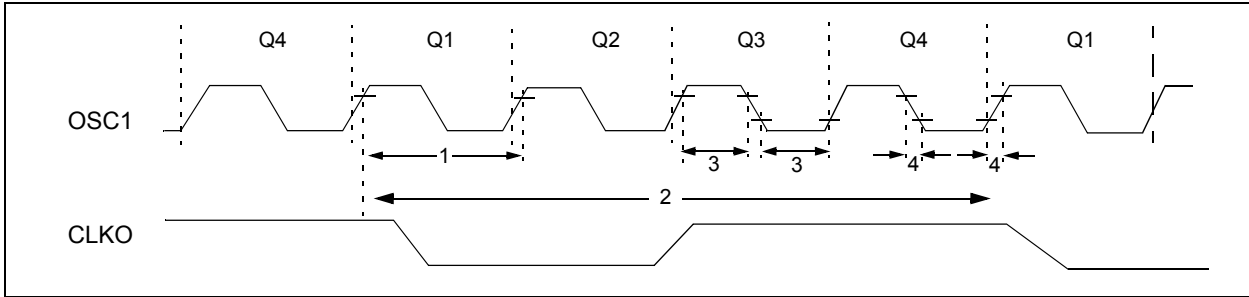
**FIGURE 29-3: LOAD CONDITIONS FOR DEVICE TIMING SPECIFICATIONS**





## 29.4.3 TIMING DIAGRAMS AND SPECIFICATIONS

**FIGURE 29-4: EXTERNAL CLOCK TIMING**



**TABLE 29-7: EXTERNAL CLOCK TIMING REQUIREMENTS**

Param. No.	Symbol	Characteristic	Min.	Max.	Units	Conditions
1A	Fosc	External CLKI Frequency <sup>(1)</sup>	DC	48	MHz	EC Oscillator mode
		Oscillator Frequency <sup>(1)</sup>	DC	10	MHz	ECPLL Oscillator mode
			4	25		HS Oscillator mode
			4	10		HSPLL Oscillator mode
1	Tosc	External CLKI Period <sup>(1)</sup>	20.8	—	ns	EC Oscillator mode
		Oscillator Period <sup>(1)</sup>	100	—	ns	ECPLL Oscillator mode
			40.0	250		HS Oscillator mode
			100	250		HSPLL Oscillator mode
2	Tcy	Instruction Cycle Time <sup>(1)</sup>	83.3	—	ns	Tcy = 4/Fosc, Industrial
3	TosL, TosH	External Clock in (OSC1) High or Low Time	10	—	ns	HS Oscillator mode
4	TosR, TosF	External Clock in (OSC1) Rise or Fall Time	—	7.5	ns	HS Oscillator mode

**Note 1:** Instruction cycle period (Tcy) equals four times the input oscillator time base period for all configurations except PLL. All specified values are based on characterization data for that particular oscillator type under standard operating conditions with the device executing code. Exceeding these specified limits may result in an unstable oscillator operation and/or higher than expected current consumption. All devices are tested to operate at “min.” values with an external clock applied to the OSC1/CLKI pin. When an external clock input is used, the “max.” cycle time limit is “DC” (no clock) for all devices.

**TABLE 29-8: PLL CLOCK TIMING SPECIFICATIONS (VDD = 2.15V TO 3.6V)**

Param. No.	Sym.	Characteristic	Min.	Typ†	Max.	Units	Conditions
F10	FOSC	Oscillator Frequency Range	4	—	10	MHz	HS mode
F11	FSYS	On-Chip VCO System Frequency	16	—	40	MHz	HS mode
F12	t <sub>rc</sub>	PLL Start-up Time (Lock Time)	—	—	2	ms	
F13	ΔCLK	CLKO Stability (Jitter)	-2	—	+2	%	

† Data in “Typ” column is at 3.3V, 25°C, unless otherwise stated. These parameters are for design guidance only and are not tested.

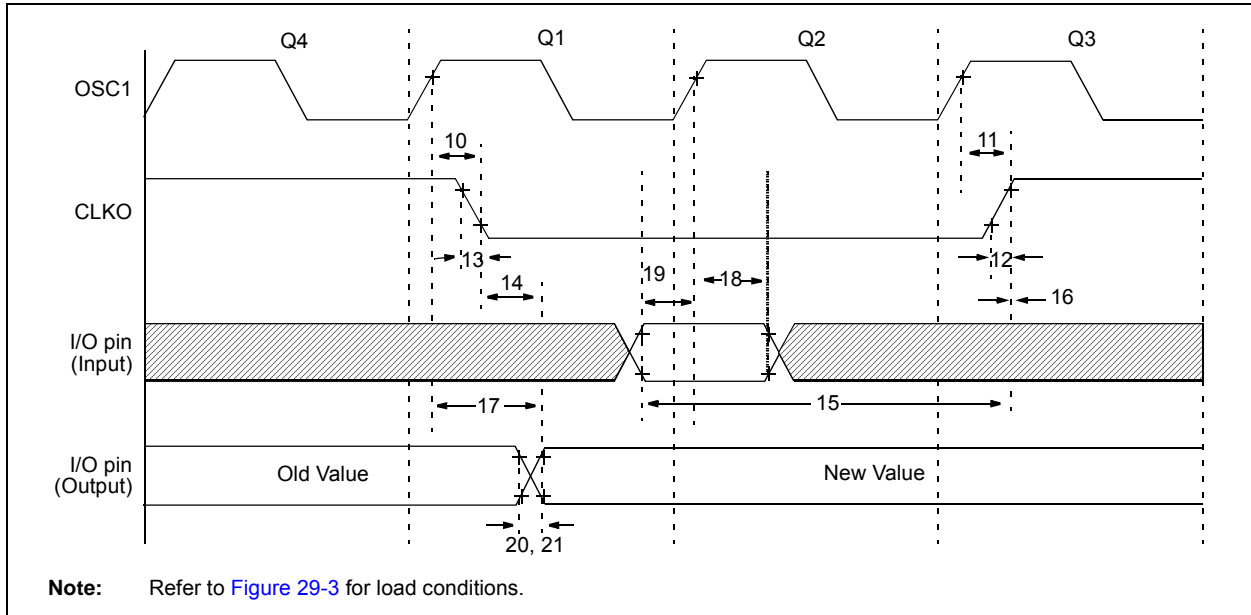
# PIC18F87J72

**TABLE 29-1: INTERNAL RC ACCURACY (INTOSC AND INTRC SOURCES)**

PIC18F87J72 Family (Industrial)		Standard Operating Conditions (unless otherwise stated) Operating temperature $-40^{\circ}\text{C} \leq T_A \leq +85^{\circ}\text{C}$ for industrial					
Param. No.	Device	Min.	Typ.	Max.	Units	Conditions	
<b>INTOSC Accuracy @ Freq = 8 MHz, 4 MHz, 2 MHz, 1 MHz, 500 kHz, 250 kHz, 125 kHz, 31 kHz<sup>(1)</sup></b>							
	All Devices	-2	+/-1	2	%	+25°C	V <sub>DD</sub> = 2.7-3.3V
		-5	—	5	%	-10°C to +85°C	V <sub>DD</sub> = 2.0-3.3V
		-10	+/-1	10	%	-40°C to +85°C	V <sub>DD</sub> = 2.0-3.3V
<b>INTRC Accuracy @ Freq = 31 kHz<sup>(1)</sup></b>							
	All Devices	21.7	—	40.3	kHz	-40°C to +85°C	V <sub>DD</sub> = 2.0-3.3V

**Note 1:** The accuracy specification of the 31 kHz clock is determined by which source is providing it at a given time. When INTSRC (OSCTUNE<7>) is '1', use the INTOSC accuracy specification. When INTSRC is '0', use the INTRC accuracy specification.

**FIGURE 29-5: CLKO AND I/O TIMING**



**TABLE 29-1: CLKO AND I/O TIMING REQUIREMENTS**

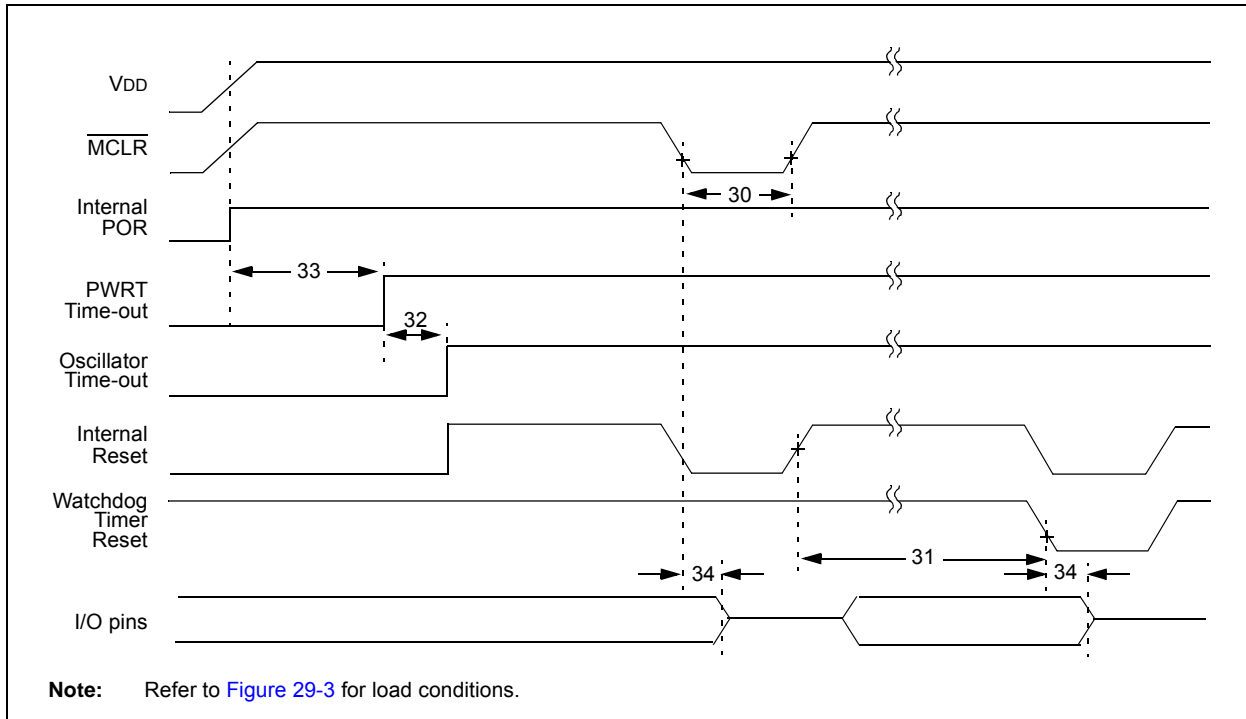
Param. No.	Symbol	Characteristic	Min.	Typ.	Max.	Units	Conditions
10	TosH2ckL	OSC1 ↑ to CLKO ↓	—	75	200	ns	(Note 1)
11	TosH2ckH	OSC1 ↑ to CLKO ↑	—	75	200	ns	(Note 1)
12	TckR	CLKO Rise Time	—	15	30	ns	(Note 1)
13	TckF	CLKO Fall Time	—	15	30	ns	(Note 1)
14	TckL2ioV	CLKO ↓ to Port Out Valid	—	—	0.5 T <sub>cy</sub> + 20	ns	
15	TioV2ckH	Port In Valid before CLKO ↑	0.25 T <sub>cy</sub> + 25	—	—	ns	
16	TckH2ioI	Port In Hold after CLKO ↑	0	—	—	ns	
17	TosH2ioV	OSC1 ↑ (Q1 cycle) to Port Out Valid	—	50	150	ns	
18	TosH2ioI	OSC1 ↑ (Q2 cycle) to Port Input Invalid (I/O in hold time)	100	—	—	ns	
19	TioV2osH	Port Input Valid to OSC1 ↑ (I/O in setup time)	0	—	—	ns	
20	TioR	Port Output Rise Time	—	—	6	ns	
21	TioF	Port Output Fall Time	—	—	5	ns	
22†	TINP	INTx Pin High or Low Time	T <sub>cy</sub>	—	—	ns	
23†	TRBP	RB<7:4> Change INTx High or Low Time	T <sub>cy</sub>	—	—	ns	

† These parameters are asynchronous events not related to any internal clock edges.

**Note 1:** Measurements are taken in EC mode, where CLKO output is 4 x T<sub>osc</sub>.

# PIC18F87J72

**FIGURE 29-6: RESET, WATCHDOG TIMER, OSCILLATOR START-UP TIMER AND POWER-UP TIMER TIMING**

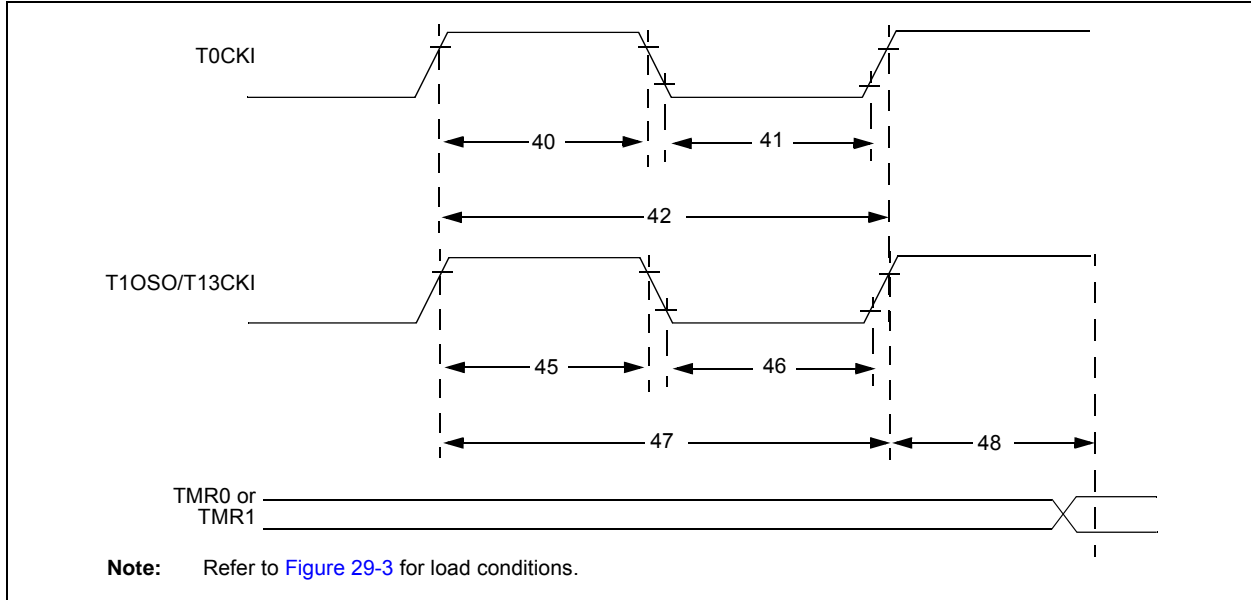


**TABLE 29-2: RESET, WATCHDOG TIMER, OSCILLATOR START-UP TIMER, POWER-UP TIMER AND BROWN-OUT RESET REQUIREMENTS**

Param. No.	Symbol	Characteristic	Min.	Typ.	Max.	Units	Conditions
30	TMCL	MCLR Pulse Width (low)	2 T <sub>CY</sub>	10 T <sub>CY</sub>	—		(Note 1)
31	TWDT	Watchdog Timer Time-out Period (no postscaler)	3.4	4.0	4.6	ms	
32	TOST	Oscillation Start-up Timer Period	1024 T <sub>OSC</sub>	—	1024 T <sub>OSC</sub>		T <sub>OSC</sub> = OSC1 period
33	TPWRT	Power-up Timer Period	45.8	65.5	85.2	ms	
34	TIOZ	I/O High-Impedance from $\overline{\text{MCLR}}$ Low or Watchdog Timer Reset	—	2	—	μs	
38	TCSD	CPU Start-up Time	—	10	—	μs	
				200		μs	
39	TIOBST	Time for INTOSC to Stabilize	—	1	—	μs	

**Note 1:** To ensure device Reset,  $\overline{\text{MCLR}}$  must be low for at least 2 T<sub>CY</sub> or 400 μs, whichever is lower.

**FIGURE 29-7: TIMER0 AND TIMER1 EXTERNAL CLOCK TIMINGS**

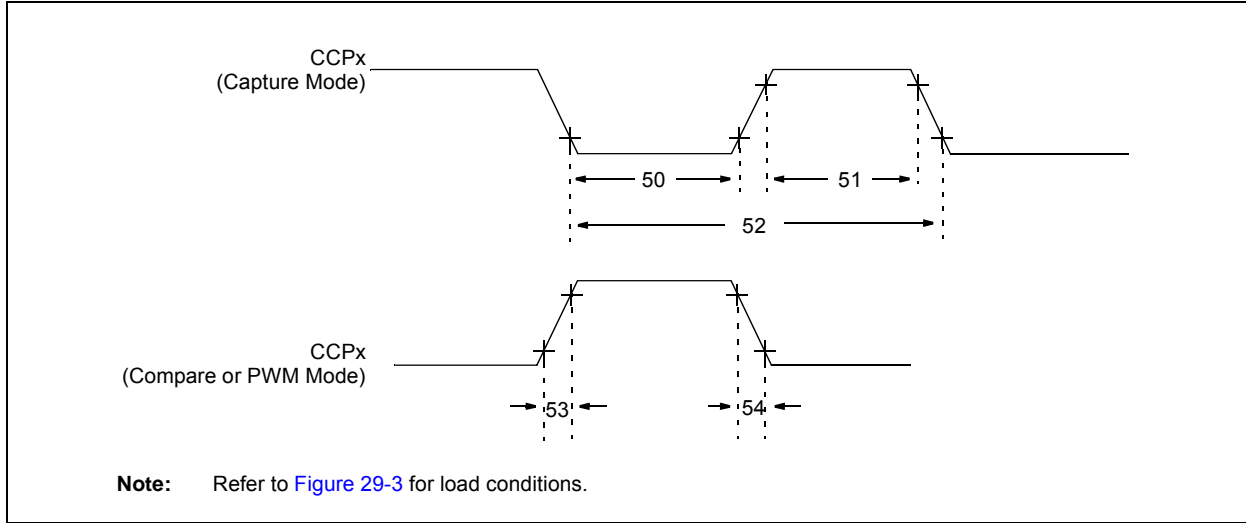


**TABLE 29-3: TIMER0 AND TIMER1 EXTERNAL CLOCK REQUIREMENTS**

Param. No.	Symbol	Characteristic		Min.	Max.	Units	Conditions
40	T <sub>T0H</sub>	T0CKI High Pulse Width	No prescaler	$0.5 T_{CY} + 20$	—	ns	
			With prescaler	10	—	ns	
41	T <sub>T0L</sub>	T0CKI Low Pulse Width	No prescaler	$0.5 T_{CY} + 20$	—	ns	
			With prescaler	10	—	ns	
42	T <sub>T0P</sub>	T0CKI Period	No prescaler	$T_{CY} + 10$	—	ns	
			With prescaler	Greater of: 20 ns or $(T_{CY} + 40)/N$	—	ns	
45	T <sub>T1H</sub>	T13CKI High Time	Synchronous, no prescaler	$0.5 T_{CY} + 20$	—	ns	
			Synchronous, with prescaler	10	—	ns	
			Asynchronous	30	—	ns	
46	T <sub>T1L</sub>	T13CKI Low Time	Synchronous, no prescaler	$0.5 T_{CY} + 5$	—	ns	
			Synchronous, with prescaler	10	—	ns	
			Asynchronous	30	—	ns	
47	T <sub>T1P</sub>	T13CKI Input Period	Synchronous	Greater of: 20 ns or $(T_{CY} + 40)/N$	—	ns	N = prescale value (1, 2, 4, 8)
			Asynchronous	60	—	ns	
	FT1	T13CKI Oscillator Input Frequency Range		DC	50	kHz	
48	T <sub>CKE2TMR1</sub>	Delay from External T13CKI Clock Edge to Timer Increment		$2 T_{OSC}$	$7 T_{OSC}$	—	

# PIC18F87J72

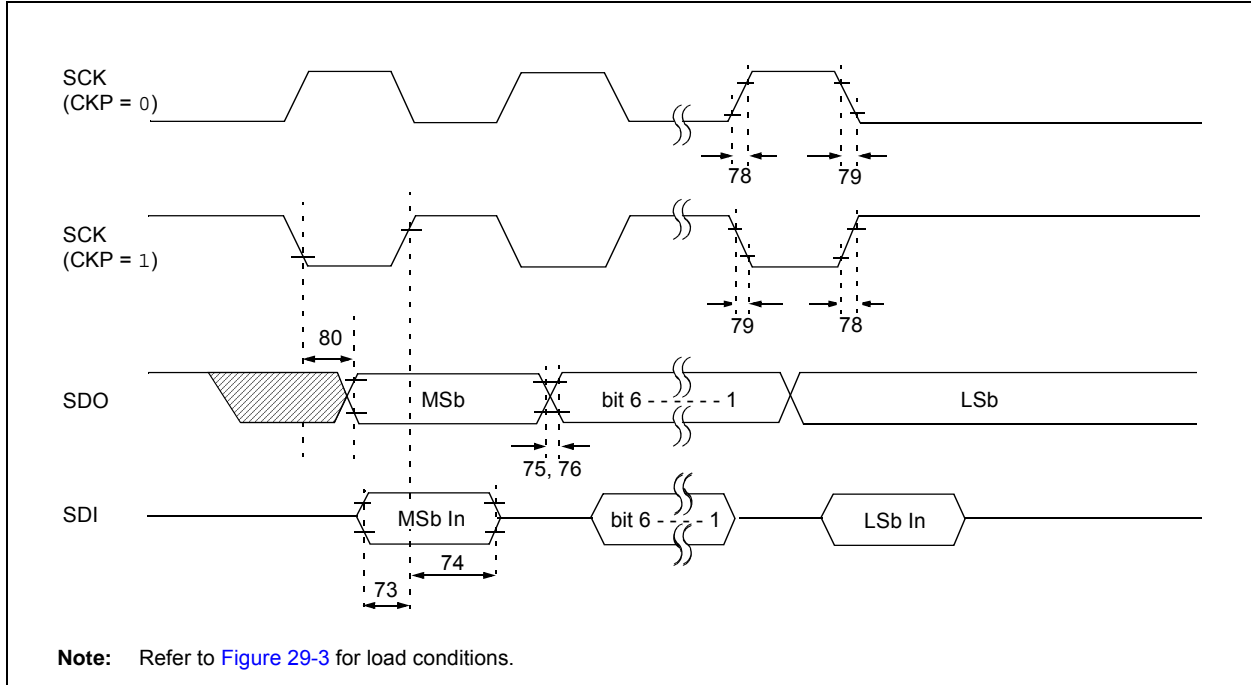
**FIGURE 29-8: CAPTURE/COMPARE/PWM TIMINGS (CCP1, CCP2 MODULES)**



**TABLE 29-4: CAPTURE/COMPARE/PWM REQUIREMENTS (CCP1, CCP2 MODULES)**

Param. No.	Symbol	Characteristic		Min.	Max.	Units	Conditions
50	TccL	CCPx Input Low Time	No prescaler	$0.5 T_{CY} + 20$	—	ns	
			With prescaler	10	—	ns	
51	TccH	CCPx Input High Time	No prescaler	$0.5 T_{CY} + 20$	—	ns	
			With prescaler	10	—	ns	
52	TccP	CCPx Input Period		$\frac{3 T_{CY} + 40}{N}$	—	ns	N = prescale value (1, 4 or 16)
53	TccR	CCPx Output Fall Time		—	25	ns	
54	TccF	CCPx Output Fall Time		—	25	ns	

**FIGURE 29-9: EXAMPLE SPI MASTER MODE TIMING (CKE = 0)**



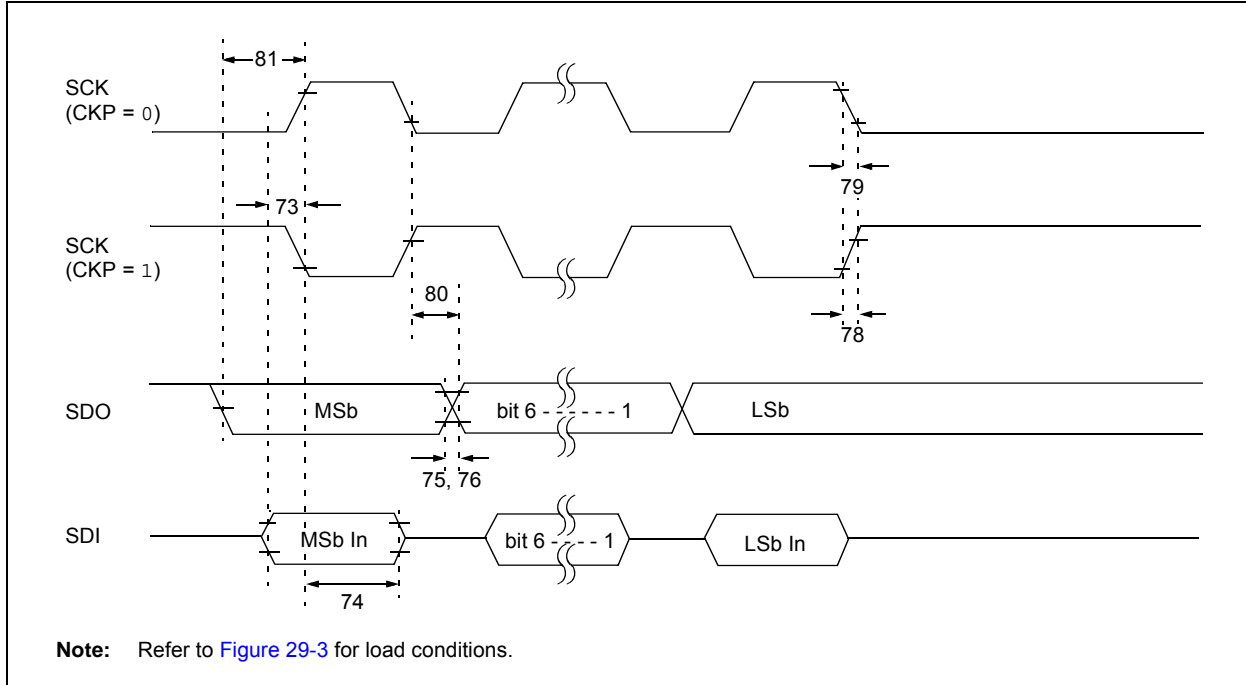
**TABLE 29-5: EXAMPLE SPI MODE REQUIREMENTS (MASTER MODE, CKE = 0)**

Param. No.	Symbol	Characteristic	Min.	Max.	Units	Conditions
73	TdIV2SCH, TdIV2SCL	Setup Time of SDI Data Input to SCK Edge	20	—	ns	
73A	Tb2B	Last Clock Edge of Byte 1 to the 1st Clock Edge of Byte 2	1.5 T <sub>CY</sub> + 40	—	ns	
74	Tsch2dIL, TscL2dIL	Hold Time of SDI Data Input to SCK Edge	40	—	ns	
75	TdOR	SDO Data Output Rise Time	—	25	ns	
76	TdOF	SDO Data Output Fall Time	—	25	ns	
78	TscR	SCK Output Rise Time (Master mode)	—	25	ns	
79	TscF	SCK Output Fall Time (Master mode)	—	25	ns	
80	Tsch2dOV, TscL2dOV	SDO Data Output Valid after SCK Edge	—	50	ns	

**Note 1:** Requires the use of Parameter #73A.

# PIC18F87J72

**FIGURE 29-10: EXAMPLE SPI MASTER MODE TIMING (CKE = 1)**



**TABLE 29-6: EXAMPLE SPI MODE REQUIREMENTS (MASTER MODE, CKE = 1)**

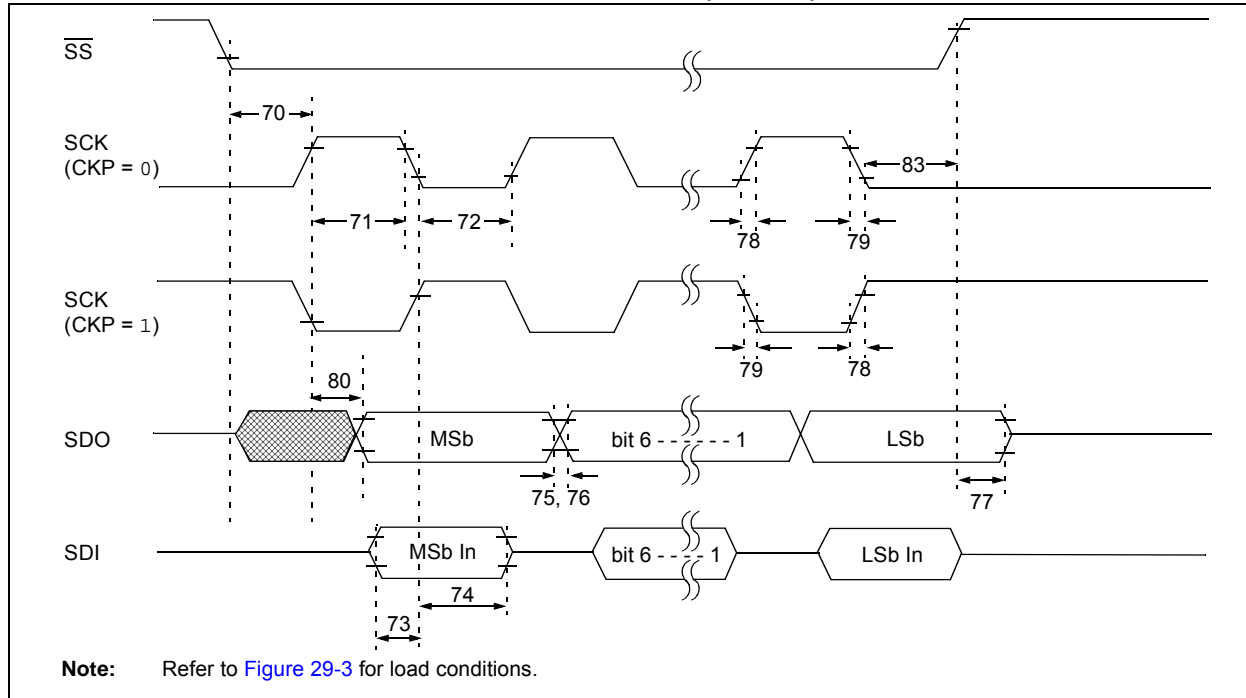
Param. No.	Symbol	Characteristic	Min.	Max.	Units	Conditions
73	TdIV2SCH, TdIV2sCL	Setup Time of SDI Data Input to SCK Edge	20	—	ns	
73A	Tb2B	Last Clock Edge of Byte 1 to the 1st Clock Edge of Byte 2	$1.5 T_{CY} + 40$	—	ns	<b>(Note 2)</b>
74	TsCH2dIL, TsCL2dIL	Hold Time of SDI Data Input to SCK Edge	40	—	ns	
75	TdoR	SDO Data Output Rise Time	—	25	ns	
76	TdoF	SDO Data Output Fall Time	—	25	ns	
78	TscR	SCK Output Rise Time (Master mode)	—	25	ns	
79	TscF	SCK Output Fall Time (Master mode)	—	25	ns	
80	TsCH2doV, TsCL2doV	SDO Data Output Valid after SCK Edge	—	50	ns	
81	TdoV2sc, TdoV2sCL	SDO Data Output Setup to SCK Edge	$T_{CY}$	—	ns	

**Note 1:** Requires the use of Parameter #73A.

**Note 2:** Only if Parameter #71A and #72A are used.



**FIGURE 29-11: EXAMPLE SPI SLAVE MODE TIMING (CKE = 0)**



**TABLE 29-7: EXAMPLE SPI MODE REQUIREMENTS (SLAVE MODE TIMING, CKE = 0)**

Param. No.	Symbol	Characteristic	Min.	Max.	Units	Conditions
70	TssL2scH, TssL2scL	$\overline{SS} \downarrow$ to SCK $\downarrow$ or SCK $\uparrow$ Input	3 T <sub>CY</sub>	—	ns	
70A	TssL2WB	$\overline{SS}$ to write to SSPBUF	3 T <sub>CY</sub>	—	ns	
71	Tsch	SCK Input High Time (Slave mode)	Continuous	1.25 T <sub>CY</sub> + 30	ns	
71A		Single Byte	40	—	ns	(Note 1)
72	Tscl	SCK Input Low Time (Slave mode)	Continuous	1.25 T <sub>CY</sub> + 30	ns	
72A		Single Byte	40	—	ns	(Note 1)
73	TdIV2scH, TdIV2scL	Setup Time of SDI Data Input to SCK Edge	100	—	ns	
73A	Tb2B	Last Clock Edge of Byte 1 to the First Clock Edge of Byte 2	1.5 T <sub>CY</sub> + 40	—	ns	(Note 2)
74	Tsch2dIL, TscL2dIL	Hold Time of SDI Data Input to SCK Edge	100	—	ns	
75	TdoR	SDO Data Output Rise Time	—	25	ns	
76	TdoF	SDO Data Output Fall Time	—	25	ns	
77	Tssh2boZ	$\overline{SS} \uparrow$ to SDO Output High-Impedance	10	50	ns	
78	TscR	SCK Output Rise Time (Master mode)	—	25	ns	
79	TscF	SCK Output Fall Time (Master mode)	—	25	ns	
80	Tsch2boV, TscL2boV	SDO Data Output Valid after SCK Edge	—	50	ns	

**Note 1:** Requires the use of Parameter #73A.

**Note 2:** Only if Parameter #71A and #72A are used.

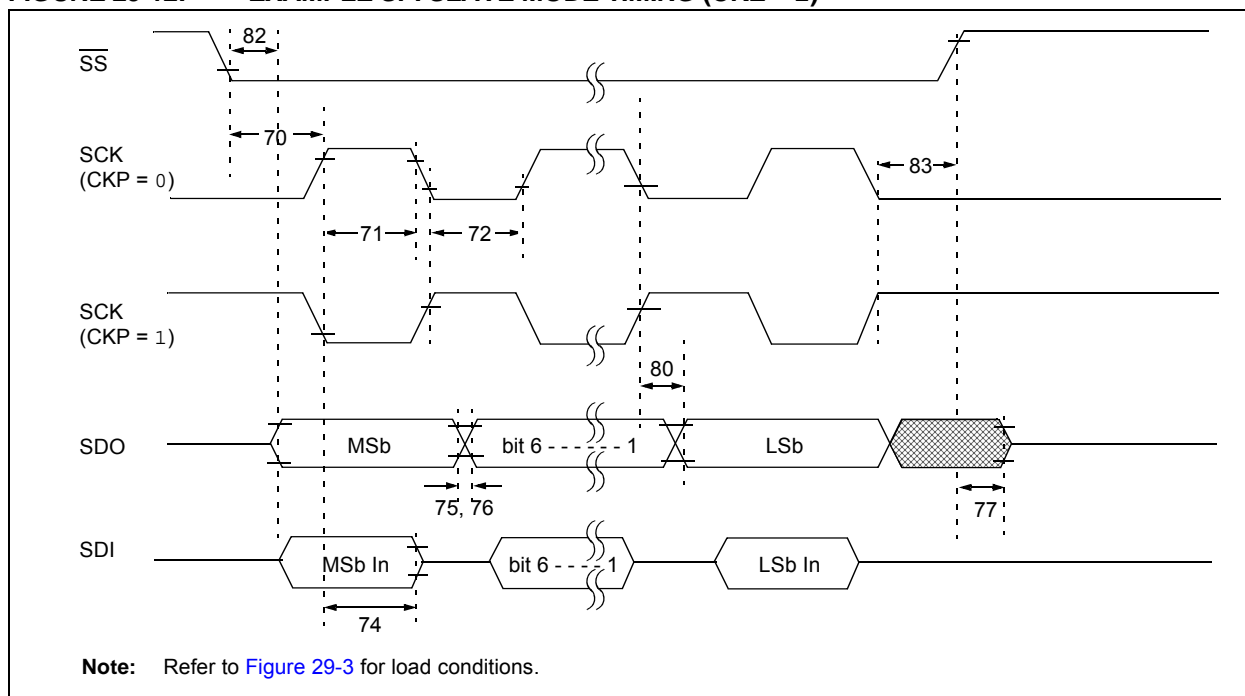
# PIC18F87J72

**TABLE 29-7: EXAMPLE SPI MODE REQUIREMENTS (SLAVE MODE TIMING, CKE = 0)**

Param. No.	Symbol	Characteristic	Min.	Max.	Units	Conditions
83	Tsch2ssH, TscL2ssH	$\overline{SS} \uparrow$ after SCK Edge	$1.5 T_{CY} + 40$	—	ns	

- Note 1:** Requires the use of Parameter #73A.  
**Note 2:** Only if Parameter #71A and #72A are used.

**FIGURE 29-12: EXAMPLE SPI SLAVE MODE TIMING (CKE = 1)**



**TABLE 29-8: EXAMPLE SPI SLAVE MODE REQUIREMENTS (CKE = 1)**

Param No.	Symbol	Characteristic	Min.	Max.	Units	Conditions
70	TssL2sch, TssL2scl	$\overline{SS} \downarrow$ to SCK $\downarrow$ or SCK $\uparrow$ Input	$3 T_{CY}$	—	ns	
70A	TssL2WB	$\overline{SS}$ to Write to SSPBUF	$3 T_{CY}$	—	ns	
71	Tsch	SCK Input High Time (Slave mode)	Continuous	$1.25 T_{CY} + 30$	—	ns
71A			Single Byte	40	—	ns
72	TscL	SCK Input Low Time (Slave mode)	Continuous	$1.25 T_{CY} + 30$	—	ns
72A			Single Byte	40	—	ns
73A	Tb2B	Last Clock Edge of Byte 1 to the First Clock Edge of Byte 2	$1.5 T_{CY} + 40$	—	ns	<b>(Note 2)</b>
74	Tsch2diL, TscL2diL	Hold Time of SDI Data Input to SCK Edge	100	—	ns	
75	TdoR	SDO Data Output Rise Time	—	25	ns	

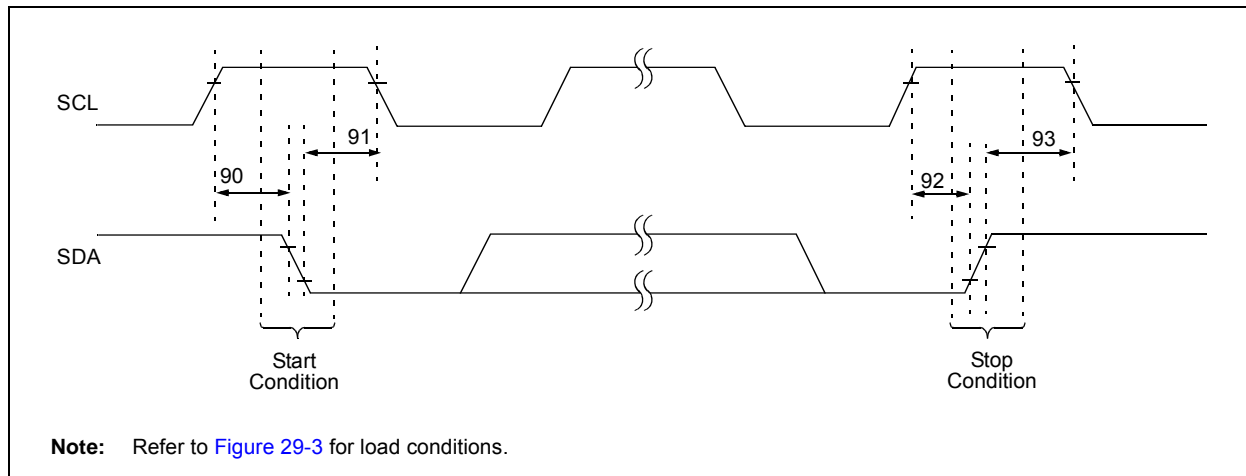
- Note 1:** Requires the use of Parameter #73A.  
**Note 2:** Only if Parameter #71A and #72A are used.

**TABLE 29-8: EXAMPLE SPI SLAVE MODE REQUIREMENTS (CKE = 1) (CONTINUED)**

Param No.	Symbol	Characteristic	Min.	Max.	Units	Conditions
76	TdoF	SDO Data Output Fall Time	—	25	ns	
77	TssH2doZ	$\overline{SS} \uparrow$ to SDO Output High-Impedance	10	50	ns	
78	TscR	SCK Output Rise Time (Master mode)	—	25	ns	
79	TscF	SCK Output Fall Time (Master mode)	—	25	ns	
80	Tsch2doV, TscL2doV	SDO Data Output Valid after SCK Edge	—	50	ns	
82	Tssl2doV	SDO Data Output Valid after $\overline{SS} \downarrow$ Edge	—	50	ns	
83	Tsch2ssH, TscL2ssH	$\overline{SS} \uparrow$ after SCK Edge	1.5 TcY + 40	—	ns	

- Note 1:** Requires the use of Parameter #73A.  
**Note 2:** Only if Parameter #71A and #72A are used.

**FIGURE 29-13: I<sup>2</sup>C BUS START/STOP BITS TIMING**



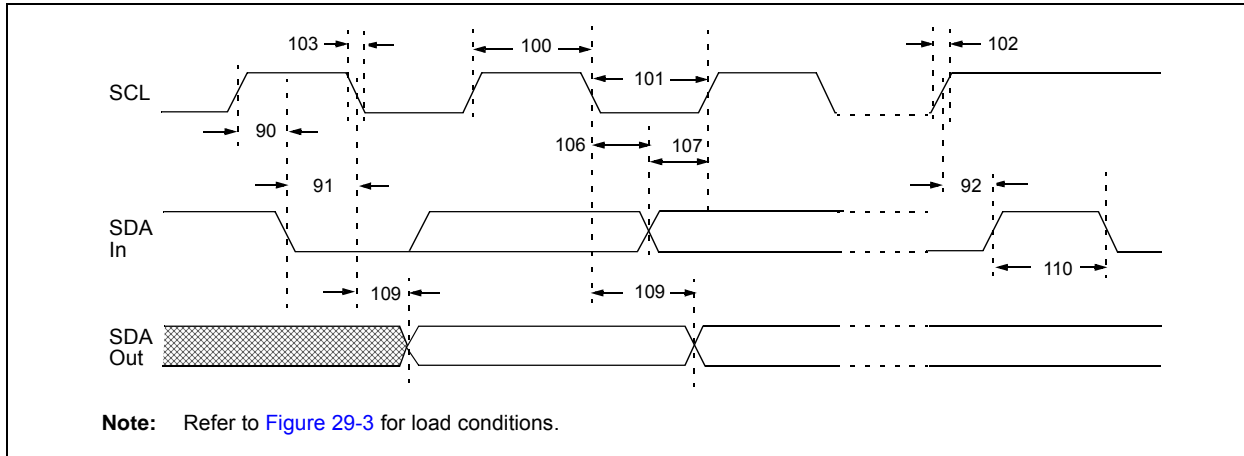
# PIC18F87J72

---

**TABLE 29-9: I<sup>2</sup>C BUS START/STOP BITS REQUIREMENTS (SLAVE MODE)**

Param. No.	Symbol	Characteristic	Min.	Max.	Units	Conditions	
90	TSU:STA	Start Condition Setup Time	100 kHz mode	4700	—	ns	Only relevant for Repeated Start condition
			400 kHz mode	600	—		
91	THD:STA	Start Condition Hold Time	100 kHz mode	4000	—	ns	After this period, the first clock pulse is generated
			400 kHz mode	600	—		
92	TSU:STO	Stop Condition Setup Time	100 kHz mode	4700	—	ns	
			400 kHz mode	600	—		
93	THD:STO	Stop Condition Hold Time	100 kHz mode	4000	—	ns	
			400 kHz mode	600	—		

**FIGURE 29-14: I<sup>2</sup>C BUS DATA TIMING**



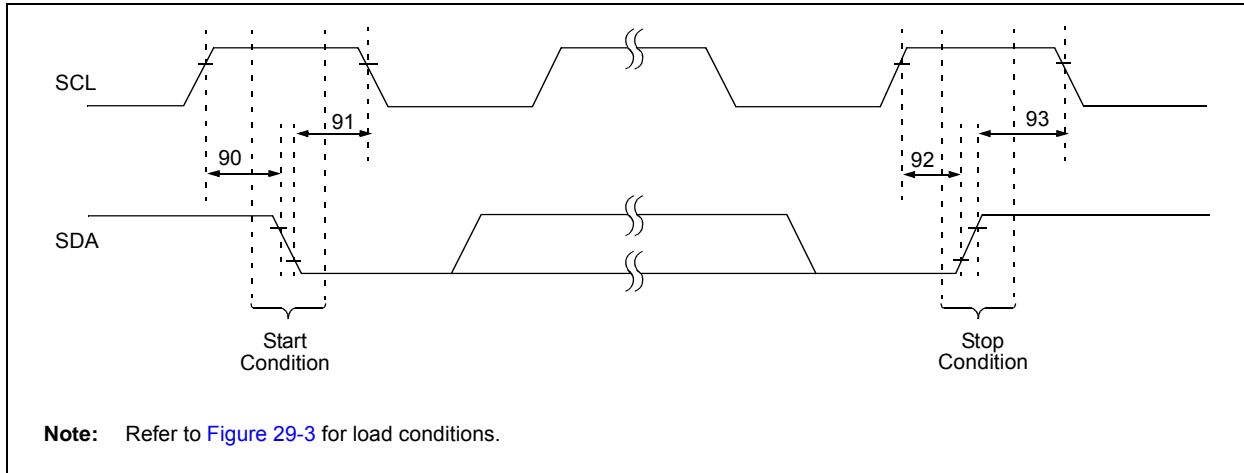
**TABLE 29-10: I<sup>2</sup>C BUS DATA REQUIREMENTS (SLAVE MODE)**

Param. No.	Symbol	Characteristic	Min.	Max.	Units	Conditions	
100	THIGH	Clock High Time	100 kHz mode	4.0	—	μs	
			400 kHz mode	0.6	—	μs	
			MSSP Module	1.5 T <sub>CY</sub>	—		
101	TLOW	Clock Low Time	100 kHz mode	4.7	—	μs	
			400 kHz mode	1.3	—	μs	
			MSSP Module	1.5 T <sub>CY</sub>	—		
102	TR	SDA and SCL Rise Time	100 kHz mode	—	1000	ns	
			400 kHz mode	20 + 0.1 C <sub>B</sub>	300	ns	C <sub>B</sub> is specified to be from 10 to 400 pF
103	TF	SDA and SCL Fall Time	100 kHz mode	—	300	ns	
			400 kHz mode	20 + 0.1 C <sub>B</sub>	300	ns	C <sub>B</sub> is specified to be from 10 to 400 pF
90	TSU:STA	Start Condition Setup Time	100 kHz mode	4.7	—	μs	Only relevant for Repeated Start condition
			400 kHz mode	0.6	—	μs	
91	THD:STA	Start Condition Hold Time	100 kHz mode	4.0	—	μs	After this period, the first clock pulse is generated
			400 kHz mode	0.6	—	μs	
106	THD:DAT	Data Input Hold Time	100 kHz mode	0	—	ns	
			400 kHz mode	0	0.9	μs	
107	TSU:DAT	Data Input Setup Time	100 kHz mode	250	—	ns	<b>(Note 2)</b>
			400 kHz mode	100	—	ns	
92	TSU:STO	Stop Condition Setup Time	100 kHz mode	4.7	—	μs	
			400 kHz mode	0.6	—	μs	
109	TAA	Output Valid from Clock	100 kHz mode	—	3500	ns	<b>(Note 1)</b>
			400 kHz mode	—	—	ns	
110	TBUF	Bus Free Time	100 kHz mode	4.7	—	μs	Time the bus must be free before a new transmission can start
			400 kHz mode	1.3	—	μs	
D102	CB	Bus Capacitive Loading	—	400	pF		

- Note 1:** As a transmitter, the device must provide this internal minimum delay time to bridge the undefined region (min. 300 ns) of the falling edge of SCL to avoid unintended generation of Start or Stop conditions.
- Note 2:** A Fast mode I<sup>2</sup>C bus device can be used in a Standard mode I<sup>2</sup>C bus system, but the requirement, TSU:DAT ≥ 250 ns, must then be met. This will automatically be the case if the device does not stretch the LOW period of the SCL signal. If such a device does stretch the LOW period of the SCL signal, it must output the next data bit to the SDA line, TR max. + TSU:DAT = 1000 + 250 = 1250 ns (according to the Standard mode I<sup>2</sup>C bus specification), before the SCL line is released.

# PIC18F87J72

**FIGURE 29-15: MSSP I<sup>2</sup>C BUS START/STOP BITS TIMING WAVEFORMS**



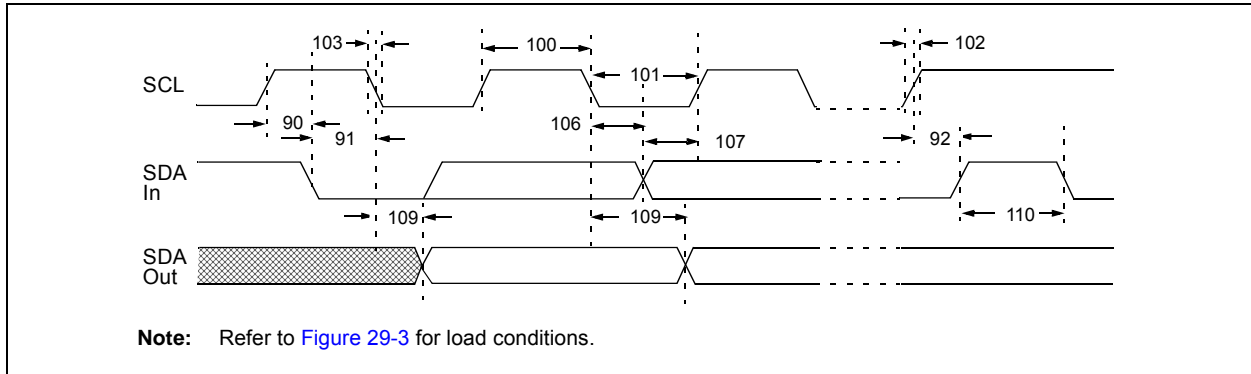
**TABLE 29-11: MSSP I<sup>2</sup>C BUS START/STOP BITS REQUIREMENTS**

Param. No.	Symbol	Characteristic	Min.	Max.	Units	Conditions
90	TSU:STA	Start Condition Setup Time	100 kHz mode	$2(T_{osc})(BRG + 1)$	—	ns Only relevant for Repeated Start condition
			400 kHz mode	$2(T_{osc})(BRG + 1)$	—	
			1 MHz mode <sup>(1,2)</sup>	$2(T_{osc})(BRG + 1)$	—	
91	THD:STA	Start Condition Hold Time	100 kHz mode	$2(T_{osc})(BRG + 1)$	—	ns After this period, the first clock pulse is generated
			400 kHz mode	$2(T_{osc})(BRG + 1)$	—	
			1 MHz mode <sup>(1,2)</sup>	$2(T_{osc})(BRG + 1)$	—	
92	TSU:STO	Stop Condition Setup Time	100 kHz mode	$2(T_{osc})(BRG + 1)$	—	ns
			400 kHz mode	$2(T_{osc})(BRG + 1)$	—	
			1 MHz mode <sup>(1,2)</sup>	$2(T_{osc})(BRG + 1)$	—	
93	THD:STO	Stop Condition Hold Time	100 kHz mode	$2(T_{osc})(BRG + 1)$	—	ns
			400 kHz mode	$2(T_{osc})(BRG + 1)$	—	
			1 MHz mode <sup>(1,2)</sup>	$2(T_{osc})(BRG + 1)$	—	

**Note 1:** Maximum pin capacitance = 10 pF for all I<sup>2</sup>C pins.

**Note 2:** Fosc must be at least 16 MHz for I<sup>2</sup>C bus operation at this speed.

**FIGURE 29-16: MSSP I<sup>2</sup>C BUS DATA TIMING**



**TABLE 29-12: MSSP I<sup>2</sup>C BUS DATA REQUIREMENTS**

Param. No.	Symbol	Characteristic	Min.	Max.	Units	Conditions
100	T <sub>HIGH</sub>	Clock High Time	100 kHz mode	2(T <sub>osc</sub> )(BRG + 1)	—	μs
			400 kHz mode	2(T <sub>osc</sub> )(BRG + 1)	—	μs
			1 MHz mode <sup>(1,2)</sup>	2(T <sub>osc</sub> )(BRG + 1)	—	μs
101	T <sub>LOW</sub>	Clock Low Time	100 kHz mode	2(T <sub>osc</sub> )(BRG + 1)	—	μs
			400 kHz mode	2(T <sub>osc</sub> )(BRG + 1)	—	μs
			1 MHz mode <sup>(1,2)</sup>	2(T <sub>osc</sub> )(BRG + 1)	—	μs
102	T <sub>R</sub>	SDA and SCL Rise Time	100 kHz mode	—	1000	ns
			400 kHz mode	20 + 0.1 C <sub>B</sub>	300	ns
			1 MHz mode <sup>(1,2)</sup>	—	300	ns
103	T <sub>F</sub>	SDA and SCL Fall Time	100 kHz mode	—	300	ns
			400 kHz mode	20 + 0.1 C <sub>B</sub>	300	ns
			1 MHz mode <sup>(1,2)</sup>	—	100	ns
90	T <sub>SU:STA</sub>	Start Condition Setup Time	100 kHz mode	2(T <sub>osc</sub> )(BRG + 1)	—	μs
			400 kHz mode	2(T <sub>osc</sub> )(BRG + 1)	—	μs
			1 MHz mode <sup>(1,2)</sup>	2(T <sub>osc</sub> )(BRG + 1)	—	μs
91	T <sub>HD:STA</sub>	Start Condition Hold Time	100 kHz mode	2(T <sub>osc</sub> )(BRG + 1)	—	μs
			400 kHz mode	2(T <sub>osc</sub> )(BRG + 1)	—	μs
			1 MHz mode <sup>(1,2)</sup>	2(T <sub>osc</sub> )(BRG + 1)	—	μs
106	T <sub>HD:DAT</sub>	Data Input Hold Time	100 kHz mode	0	—	ns
			400 kHz mode	0	0.9	μs
			1 MHz mode <sup>(1,2)</sup>	—	—	ns
107	T <sub>SU:DAT</sub>	Data Input Setup Time	100 kHz mode	250	—	ns
			400 kHz mode	100	—	ns
			1 MHz mode <sup>(1,2)</sup>	—	—	ns

Legend: TBD = To Be Determined

**Note 1:** Maximum pin capacitance = 10 pF for all I<sup>2</sup>C pins.

**2:** F<sub>osc</sub> must be at least 16 MHz for I<sup>2</sup>C bus operation at this speed.

**3:** A Fast mode I<sup>2</sup>C bus device can be used in a Standard mode I<sup>2</sup>C bus system, but parameter #107 ≥ 250 ns must then be met. This will automatically be the case if the device does not stretch the LOW period of the SCL signal. If such a device does stretch the LOW period of the SCL signal, it must output the next data bit to the SDA line, parameter #102 + parameter #107 = 1000 + 250 = 1250 ns (for 100 kHz mode), before the SCL line is released.

# PIC18F87J72

**TABLE 29-12: MSSP I<sup>2</sup>C BUS DATA REQUIREMENTS (CONTINUED)**

Param. No.	Symbol	Characteristic		Min.	Max.	Units	Conditions
92	TSU:STO	Stop Condition Setup Time	100 kHz mode	$2(T_{osc})(BRG + 1)$	—	μs	
			400 kHz mode	$2(T_{osc})(BRG + 1)$	—	μs	
			1 MHz mode <sup>(1,2)</sup>	$2(T_{osc})(BRG + 1)$	—	μs	
109	TAA	Output Valid from Clock	100 kHz mode	—	3500	ns	
			400 kHz mode	—	1000	ns	
			1 MHz mode <sup>(1,2)</sup>	—	—	ns	
110	TBUF	Bus Free Time	100 kHz mode	4.7	—	μs	Time the bus must be free before a new transmission can start
			400 kHz mode	1.3	—	μs	
			1 MHz mode <sup>(1,2)</sup>	—	—	μs	
D102	CB	Bus Capacitive Loading		—	400	pF	

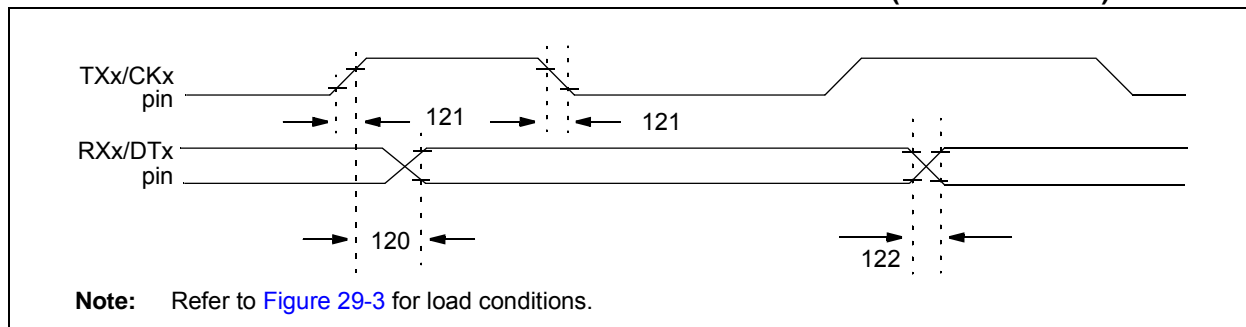
Legend: TBD = To Be Determined

**Note 1:** Maximum pin capacitance = 10 pF for all I<sup>2</sup>C pins.

**2:** FOSC must be at least 16 MHz for I<sup>2</sup>C bus operation at this speed.

**3:** A Fast mode I<sup>2</sup>C bus device can be used in a Standard mode I<sup>2</sup>C bus system, but parameter #107 ≥ 250 ns must then be met. This will automatically be the case if the device does not stretch the LOW period of the SCL signal. If such a device does stretch the LOW period of the SCL signal, it must output the next data bit to the SDA line, parameter #102 + parameter #107 = 1000 + 250 = 1250 ns (for 100 kHz mode), before the SCL line is released.

**FIGURE 29-17: EUSART/AUSART SYNCHRONOUS TRANSMISSION (MASTER/SLAVE) TIMING**

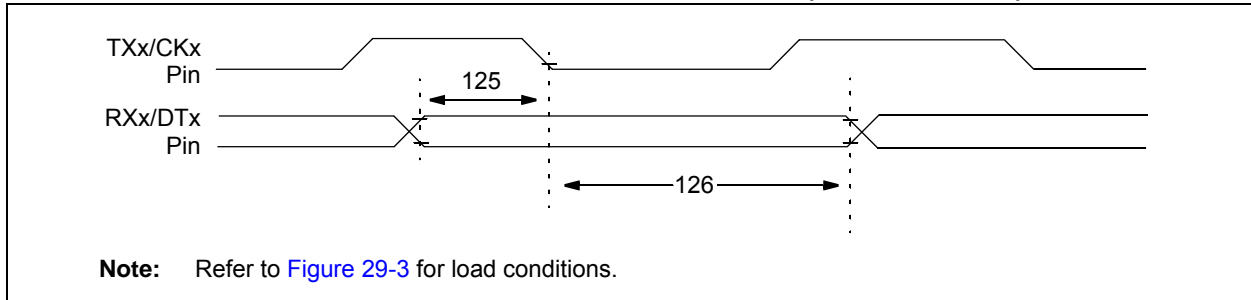


**TABLE 29-13: EUSART/AUSART SYNCHRONOUS TRANSMISSION REQUIREMENTS**

Param. No.	Symbol	Characteristic	Min.	Max.	Units	Conditions
120	TckH2dTV	SYNC XMIT (MASTER and SLAVE) Clock High to Data Out Valid	—	40	ns	
121	TCKRF	Clock Out Rise Time and Fall Time (Master mode)	—	20	ns	
122	TDTRF	Data Out Rise Time and Fall Time	—	20	ns	



**FIGURE 29-18: EUSART/AUSART SYNCHRONOUS RECEIVE (MASTER/SLAVE) TIMING**



**TABLE 29-14: EUSART/AUSART SYNCHRONOUS RECEIVE REQUIREMENTS**

Param. No.	Symbol	Characteristic	Min.	Max.	Units	Conditions
125	TDTV2CKL	SYNC RCV (MASTER and SLAVE) Data Hold before CKx ↓ (DTx hold time)	10	—	ns	
126	TCKL2DTL	Data Hold after CKx ↓ (DTx hold time)	15	—	ns	

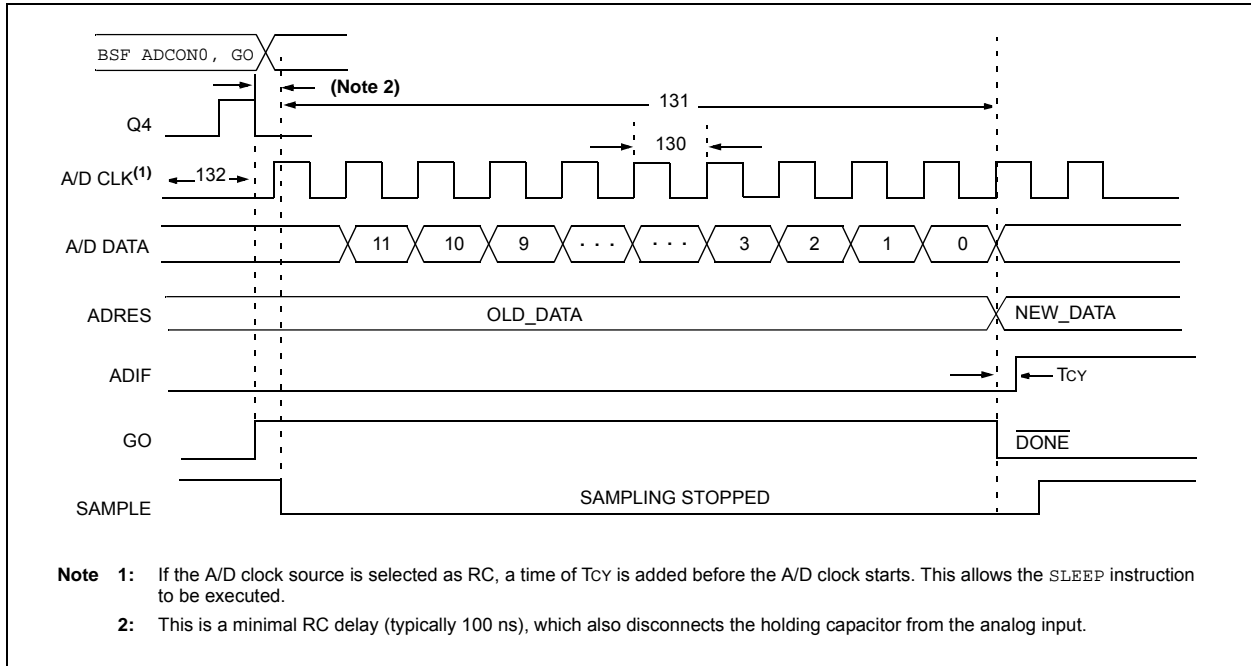
**TABLE 29-15: A/D CONVERTER CHARACTERISTICS: PIC18F87J72 FAMILY (INDUSTRIAL)**

Param. No.	Sym.	Characteristic	Min.	Typ.	Max.	Units	Conditions
A01	NR	Resolution	—	—	12	bit	$\Delta V_{REF} \geq 3.0V$
A03	EIL	Integral Linearity Error	—	$< \pm 1$	$\pm 2.0$	LSB	$\Delta V_{REF} \geq 3.0V$
A04	EDL	Differential Linearity Error	—	$< \pm 1$	$\pm 1.5$	LSB	$\Delta V_{REF} \geq 3.0V$
A06	E <sub>OFF</sub>	Offset Error	—	$< \pm 1$	$\pm 5$	LSB	$\Delta V_{REF} \geq 3.0V$
A07	E <sub>GN</sub>	Gain Error	—	$< \pm 1$	$\pm 3$	LSB	$\Delta V_{REF} \geq 3.0V$
A10	—	Monotonicity	Guaranteed <sup>(1)</sup>			—	$V_{SS} \leq V_{AIN} \leq V_{REF}$
A20	$\Delta V_{REF}$	Reference Voltage Range ( $V_{REFH} - V_{REFL}$ )	3	—	$V_{DD} - V_{SS}$	V	For 12-bit resolution
A21	$V_{REFH}$	Reference Voltage High	$V_{SS} + 3.0V$	—	$V_{DD} + 0.3V$	V	For 12-bit resolution
A22	$V_{REFL}$	Reference Voltage Low	$V_{SS} - 0.3V$	—	$V_{DD} - 3.0V$	V	For 12-bit resolution
A25	$V_{AIN}$	Analog Input Voltage	$V_{REFL}$	—	$V_{REFH}$	V	<b>Note 2</b>
A30	$Z_{AIN}$	Recommended Impedance of Analog Voltage Source	—	—	2.5	k $\Omega$	
A50	I <sub>REF</sub>	$V_{REF}$ Input Current <sup>(2)</sup>	—	—	5 150	$\mu A$ $\mu A$	During $V_{AIN}$ acquisition. During A/D conversion cycle.

- Note 1:** The A/D conversion result never decreases with an increase in the input voltage and has no missing codes.
- Note 2:**  $V_{REFH}$  current is from the RA3/AN3/ $V_{REF+}$  pin or  $V_{DD}$ , whichever is selected as the  $V_{REFH}$  source.  $V_{REFL}$  current is from the RA2/AN2/ $V_{REF-}$  pin or  $V_{SS}$ , whichever is selected as the  $V_{REFL}$  source.

# PIC18F87J72

**FIGURE 29-19: A/D CONVERSION TIMING**



**TABLE 29-16: A/D CONVERSION REQUIREMENTS**

Param. No.	Symbol	Characteristic	Min.	Max.	Units	Conditions
130	TAD	A/D Clock Period	0.8	12.5 <sup>(1)</sup>	μs	TOSC based, VREF ≥ 3.0V
131	TCNV	Conversion Time (not including acquisition time) <sup>(2)</sup>	13	14	TAD	
132	TACQ	Acquisition Time <sup>(3)</sup>	1.4	—	μs	
135	TSWC	Switching Time from Convert → Sample	—	(Note 4)		
137	TDIS	Discharge Time	0.2	—	μs	

- Note 1:** The time of the A/D clock period is dependent on the device frequency and the TAD clock divider.
- Note 2:** ADRES registers may be read on the following T<sub>cy</sub> cycle.
- Note 3:** The time for the holding capacitor to acquire the “New” input voltage when the voltage changes full scale after the conversion (V<sub>DD</sub> to V<sub>SS</sub> or V<sub>SS</sub> to V<sub>DD</sub>). The source impedance (R<sub>S</sub>) on the input channels is 50Ω.
- Note 4:** On the following cycle of the device clock.

**TABLE 29-17: DUAL-CHANNEL AFE ELECTRICAL CHARACTERISTICS**

<b>Electrical Specifications:</b> Unless otherwise indicated: SAVDD = 4.5 to 5.5V, SVDD = 2.7 to 5.5V, -40°C < TA < +85°C, MCLK = 4 MHz, PRESCALE = 1, OSR = 64, GAIN = 1, Dithering Off, VIN = -0.5, dBFS = 353 mVRMS @ 50/60 Hz						
Parameters	Symbol	Min.	Typical	Max.	Units	Conditions
<b>Internal Voltage Reference</b>						
Internal Voltage Reference Tolerance	VREF	-2%	2.37	+2%	V	VREFEXT = 0
Temperature Coefficient	TCREF	—	12	—	ppm/°C	VREFEXT = 0
Output Impedance	ZOUTREF	—	7	—	kΩ	SAVDD = 5V, VREFEXT = 0
<b>Voltage Reference Input</b>						
Input Capacitance	—	—	—	10	pF	
Differential Input Voltage Range (VREF+ – VREF-)	VREF	2.2	—	2.6	V	VREF = (VREF+ – VREF-), VREFEXT = 1
Absolute Voltage on REFIN+ Pin	VREF+	1.9	—	2.9	V	VREFEXT = 1
Absolute Voltage on REFIN- Pin	VREF-	-0.3	—	0.3	V	
<b>ADC Performance</b>						
Resolution (no missing codes)	—	24	—	—	bits	OSR = 256
Sampling Frequency	f <sub>S</sub>	125	—	1000	kHz	f <sub>S</sub> = DMCLK = MCLK/ (4 x Prescale)
Output Data Rate	f <sub>D</sub>	0.4882	—	31.25	ksps	f <sub>D</sub> = DRCLK = DMCLK/ OSR = MCLK/ (4 x Prescale x OSR)
Analog Input Absolute Voltage on CH0+, CH0-, CH1+, CH1- Pins	CHn+/-	-1	—	+1	V	All analog input channels, measured to SAVss <b>(Note 1)</b>
Analog Input Leakage Current	A <sub>IN</sub>	—	1	—	nA	<b>(Note 2)</b>
Differential Input Voltage Range	(CHn+ – CHn-)	—	—	500/GAIN	mV	<b>(Note 3)</b>
Offset Error <b>(Note 4)</b>	V <sub>OS</sub>	-3	—	+3	mV	<b>(Note 5)</b>
Offset Error Drift	—	—	3	—	μV/°C	From -40°C to +125°C
Gain Error <b>(Note 4)</b>	GE	—	-0.4	—	%	G = 1
		-2.5	—	+2.5	%	All gains
Gain Error Drift	—	—	1	—	ppm/°C	From -40°C to +125°C

- Note 1:** Outside of this range, the ADC accuracy is not specified. An extended input range of ±6V can be applied continuously to the part with no risk of damage.
- 2:** For these operating currents, the following bit settings apply: SHUTDOWN<1:0> = 00, RESET<1:0> = 00, VREFEXT = 0, CLKEXT = 0.
- 3:** This specification implies that the ADC output is valid over this entire differential range and that there is no distortion or instability across this input range. Dynamic performance is specified at -0.5 dB below the maximum signal range, VIN = -0.5 dBFS @ 50/60 Hz = 353 mVRMS, mVREF = 2.4V.
- 4:** See [Appendix B.3 “Terminology and Formulas”](#) for definitions.
- 5:** Applies to all gains. Offset error is dependent on PGA gain setting.
- 6:** This parameter is established by characterization and is not 100% tested.
- 7:** For proper operation and to keep ADC accuracy, AMCLK should always be in the range of 1 to 5 MHz with BOOST bits off. With BOOST bits on, AMCLK should be in the range of 1 to 8.192 MHz. AMCLK = MCLK/PRESCALE.
- 8:** For these operating currents, the following Configuration bit settings apply: SHUTDOWN<1:0> = 11, VREFEXT = 1, CLKEXT = 1.

# PIC18F87J72

**TABLE 29-17: DUAL-CHANNEL AFE ELECTRICAL CHARACTERISTICS (CONTINUED)**

**Electrical Specifications:** Unless otherwise indicated: SAVDD = 4.5 to 5.5V, SVDD = 2.7 to 5.5V, -40°C < TA < +85°C, MCLK = 4 MHz, PRESCALE = 1, OSR = 64, GAIN = 1, Dithering Off, VIN = -0.5, dBFS = 353 mVRMS @ 50/60 Hz

Parameters	Symbol	Min.	Typical	Max.	Units	Conditions
<b>ADC Performance (continued)</b>						
Integral Non-Linearity ( <b>Note 4</b> )	INL	—	15	—	ppm	GAIN = 1, DITHER = ON
Input Impedance	ZIN	350	—	—	kΩ	Proportional to 1/AMCLK
Signal-to-Noise and Distortion Ratio ( <b>Notes 4, 6</b> )	SINAD	—	90	—	dB	OSR = 256, DITHER = ON
		—	78	—	dB	OSR = 64, DITHER = OFF
Total Harmonic Distortion ( <b>Notes 4, 6</b> )	THD	—	-101	—	dB	OSR = 256, DITHER = ON
		—	-82	—	dB	OSR = 64, DITHER = OFF
Signal-to-Noise Ratio ( <b>Notes 4, 6</b> )	SNR	—	91	—	dB	OSR = 256, DITHER = ON
		—	81	—	dB	OSR = 64, DITHER = OFF
Spurious Free Dynamic Range ( <b>Note 4</b> )	SFDR	—	103	—	dB	OSR = 256, DITHER = ON
		—	83	—	dB	OSR = 64, DITHER = OFF
Crosstalk (50/60 Hz) ( <b>Note 4</b> )	CTALK	—	-133	—	dB	OSR = 256, DITHER = ON
AC Power Supply Rejection	AC PSRR	—	-77	—	dB	SAVDD and SVDD = 5V + 1 VPP @ 50/60 Hz
DC Power Supply Rejection	DC PSRR	—	-77	—	dB	SAVDD and SVDD = 4.5 to 5.5V
DC Common-Mode Rejection Ratio ( <b>Note 4</b> )	CMRR	—	-72	—	dB	VCM varies from -1V to +1V

- Note 1:** Outside of this range, the ADC accuracy is not specified. An extended input range of ±6V can be applied continuously to the part with no risk of damage.
- 2:** For these operating currents, the following bit settings apply: SHUTDOWN<1:0> = 00, RESET<1:0> = 00, VREFEXT = 0, CLKEXT = 0.
- 3:** This specification implies that the ADC output is valid over this entire differential range and that there is no distortion or instability across this input range. Dynamic performance is specified at -0.5 dB below the maximum signal range, VIN = -0.5 dBFS @ 50/60 Hz = 353 mVRMS, mVREF = 2.4V.
- 4:** See [Appendix B.3 “Terminology and Formulas”](#) for definitions.
- 5:** Applies to all gains. Offset error is dependent on PGA gain setting.
- 6:** This parameter is established by characterization and is not 100% tested.
- 7:** For proper operation and to keep ADC accuracy, AMCLK should always be in the range of 1 to 5 MHz with BOOST bits off. With BOOST bits on, AMCLK should be in the range of 1 to 8.192 MHz. AMCLK = MCLK/PRESCALE.
- 8:** For these operating currents, the following Configuration bit settings apply: SHUTDOWN<1:0> = 11, VREFEXT = 1, CLKEXT = 1.

**TABLE 29-17: DUAL-CHANNEL AFE ELECTRICAL CHARACTERISTICS (CONTINUED)**

<b>Electrical Specifications:</b> Unless otherwise indicated: SAVDD = 4.5 to 5.5V, SVDD = 2.7 to 5.5V, -40°C < TA < +85°C, MCLK = 4 MHz, PRESCALE = 1, OSR = 64, GAIN = 1, Dithering Off, VIN = -0.5, dBFS = 353 mVRMS @ 50/60 Hz						
Parameters	Symbol	Min.	Typical	Max.	Units	Conditions
<b>Oscillator Input</b>						
Master Clock Frequency Range	MCLK	1	—	16.384	MHz	(Note 7)
<b>Power Specifications</b>						
Operating Voltage, Analog	SAVDD	4.5	—	5.5	V	
Operating Voltage, Digital	SVDD	2.7	3.6	5.5	V	
Operating Current, Analog (Note 2)	AIDD	—	2	2.8		BOOST<1:0> = 00
		—	3.5	5.6	mA	BOOST<1:0> = 11
Operating Current, Digital	DIDD	—	0.65	0.9	mA	SVDD = 5V, MCLK = 4 MHz
		—	0.3	0.4	mA	SVDD = 2.7V, MCLK = 4 MHz
		—	1.2	1.6	mA	SVDD = 5V, MCLK = 8.192 MHz
Shutdown Current, Analog	IDDS,A	—	—	1	µA	SAVDD pin only (Note 8)
Shutdown Current, Digital	IDDS,D	—	—	1	µA	SVDD pin only (Note 8)

- Note 1:** Outside of this range, the ADC accuracy is not specified. An extended input range of ±6V can be applied continuously to the part with no risk of damage.
- 2:** For these operating currents, the following bit settings apply: SHUTDOWN<1:0> = 00, RESET<1:0> = 00, VREFEXT = 0, CLKEXT = 0.
- 3:** This specification implies that the ADC output is valid over this entire differential range and that there is no distortion or instability across this input range. Dynamic performance is specified at -0.5 dB below the maximum signal range, VIN = -0.5 dBFS @ 50/60 Hz = 353 mVRMS, mVREF = 2.4V.
- 4:** See [Appendix B.3 “Terminology and Formulas”](#) for definitions.
- 5:** Applies to all gains. Offset error is dependent on PGA gain setting.
- 6:** This parameter is established by characterization and is not 100% tested.
- 7:** For proper operation and to keep ADC accuracy, AMCLK should always be in the range of 1 to 5 MHz with BOOST bits off. With BOOST bits on, AMCLK should be in the range of 1 to 8.192 MHz. AMCLK = MCLK/PRESCALE.
- 8:** For these operating currents, the following Configuration bit settings apply: SHUTDOWN<1:0> = 11, VREFEXT = 1, CLKEXT = 1.

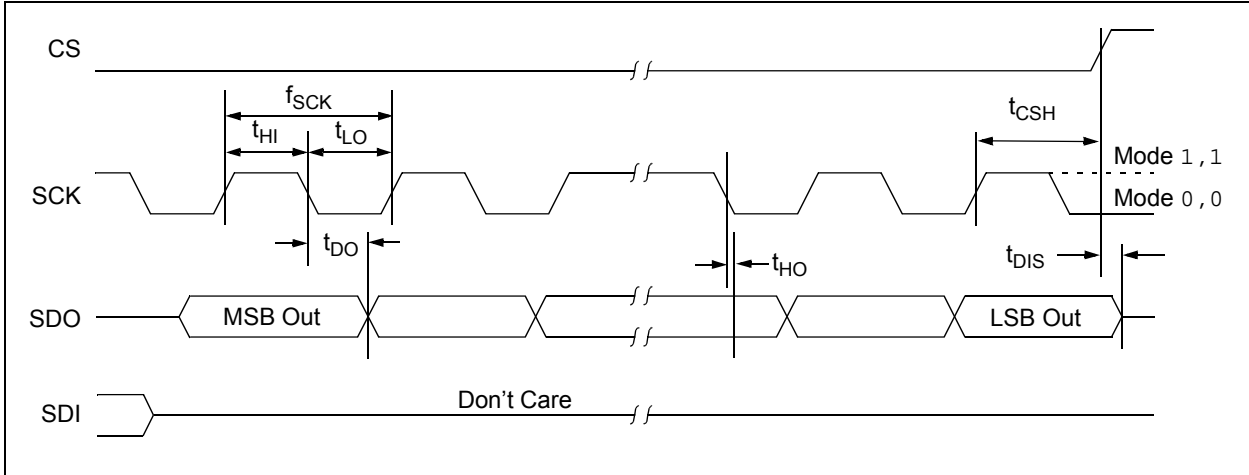
# PIC18F87J72

**TABLE 29-18: DUAL-CHANNEL AFE SERIAL PERIPHERAL INTERFACE SPECIFICATIONS**

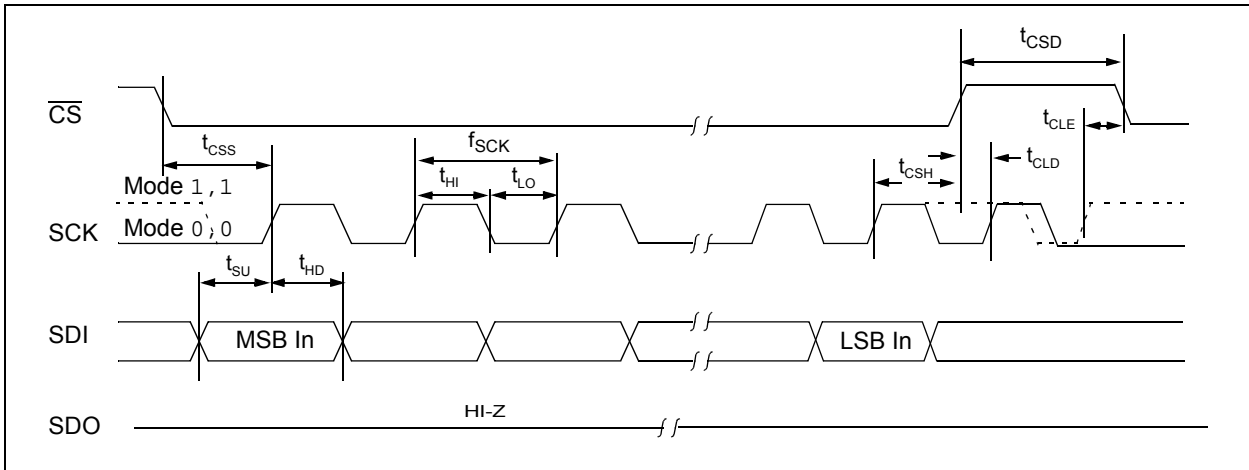
<b>Electrical Specifications:</b> Unless otherwise indicated, all parameters apply at SAVDD = 4.5 to 5.5V, DVDD = 2.7 to 5.5V, -40°C < TA < +85°C, CLOAD = 30 pF.						
Parameters	Sym.	Min.	Typ.	Max.	Units	Conditions
Serial Clock Frequency	f <sub>SCK</sub>	—	—	20	MHz	4.5 ≤ SVDD ≤ 5.5
		—	—	10	MHz	2.7 ≤ SVDD < 5.5
CS Setup Time	t <sub>CSS</sub>	25	—	—	ns	4.5 ≤ SVDD ≤ 5.5
		50	—	—	ns	2.7 ≤ SVDD < 5.5
CS Hold Time	t <sub>C<math>\overline{S}</math>H</sub>	50	—	—	ns	4.5 ≤ SVDD ≤ 5.5
		100	—	—	ns	2.7 ≤ SVDD < 5.5
CS Disable Time	t <sub>CSD</sub>	50	—	—	ns	—
Data Setup Time	t <sub>SU</sub>	5	—	—	ns	4.5 ≤ SVDD ≤ 5.5
		10	—	—	ns	2.7 ≤ SVDD < 5.5
Data Hold Time	t <sub>HD</sub>	10	—	—	ns	4.5 ≤ SVDD ≤ 5.5
		20	—	—	ns	2.7 ≤ SVDD < 5.5
Serial Clock High Time	t <sub>HI</sub>	25	—	—	ns	4.5 ≤ SVDD ≤ 5.5
		50	—	—	ns	2.7 ≤ SVDD < 5.5
Serial Clock Low Time	t <sub>LO</sub>	25	—	—	ns	4.5 ≤ DVDD ≤ 5.5
		50	—	—	ns	2.7 ≤ DVDD < 5.5
Serial Clock Delay Time	t <sub>CLD</sub>	50	—	—	ns	
Serial Clock Enable Time	t <sub>CLE</sub>	50	—	—	ns	
Output Valid from SCK Low	t <sub>DO</sub>	—	—	50	ns	2.7 ≤ SVDD < 5.5
Output hold time	t <sub>HO</sub>	0	—	—	ns	(Note 1)
Output disable time	t <sub>DIS</sub>	—	—	25	ns	4.5 ≤ SVDD ≤ 5.5
		—	—	50	ns	2.7 ≤ SVDD < 5.5 (Note 1)
Reset Pulse Width (RESET)	t <sub>MCLR</sub>	100	—	—	ns	2.7 ≤ SVDD < 5.5
Data Transfer Time to DR (Data Ready)	t <sub>DODR</sub>	—	—	50	ns	2.7 ≤ SVDD < 5.5
Data Ready Pulse Low Time	t <sub>DRP</sub>	—	1/DMCLK	—	μs	2.7 ≤ SVDD < 5.5
Schmitt Trigger High-Level Input Voltage	V <sub>IH1</sub>	0.7 SVDD	—	SVDD + 1	V	
Schmitt Trigger Low-Level Input Voltage	V <sub>IL1</sub>	-0.3	—	0.2 SVDD	V	
Hysteresis of Schmitt Trigger Inputs (all digital inputs)	V <sub>HYS</sub>	300	—	—	mV	
Low-Level Output Voltage, SDOA Pin	V <sub>OL</sub>	—	—	0.4	V	I <sub>OL</sub> = +2.5 mA, SVDD = 5.0V
Low-Level Output Voltage, DR Pin	V <sub>OL</sub>	—	—	0.4	V	I <sub>OL</sub> = +1.25 mA, SVDD = 5.0V
High-Level Output Voltage, SDOA Pin	V <sub>OH</sub>	SVDD - 0.5	—	—	V	I <sub>OH</sub> = -2.5 mA, SVDD = 5.0V
High-Level Output Voltage, DR Pin	V <sub>OH</sub>	SVDD - 0.5	—	—	V	I <sub>OH</sub> = -1.25 mA, SVDD = 5.0V
Input Leakage Current	I <sub>LI</sub>	—	—	±1	μA	CSA = SVDD, V <sub>IN</sub> = SVSS or SVDD
Output Leakage Current	I <sub>LO</sub>	—	—	±1	μA	CSA = SVDD, V <sub>OUT</sub> = SVSS or SVDD
Internal Capacitance (all inputs and outputs)	C <sub>INT</sub>	—	—	7	pF	TA = 25°C, SCKA = 1.0 MHz, SVDD = 5.0V (Note 1)

**Note 1:** This parameter is periodically sampled and is not 100% tested.

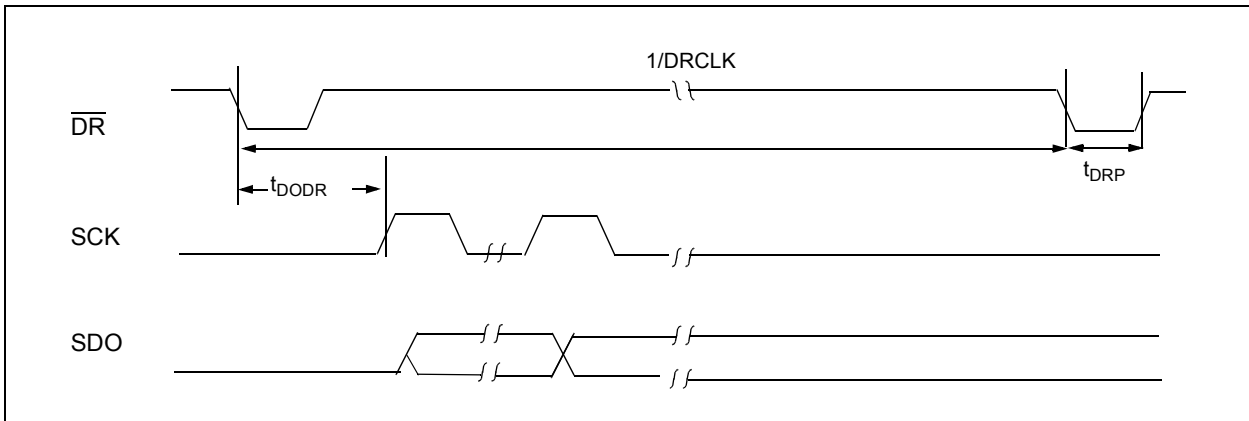
**FIGURE 29-20: SERIAL OUTPUT TIMING DIAGRAM**



**FIGURE 29-21: SERIAL INPUT TIMING DIAGRAM**

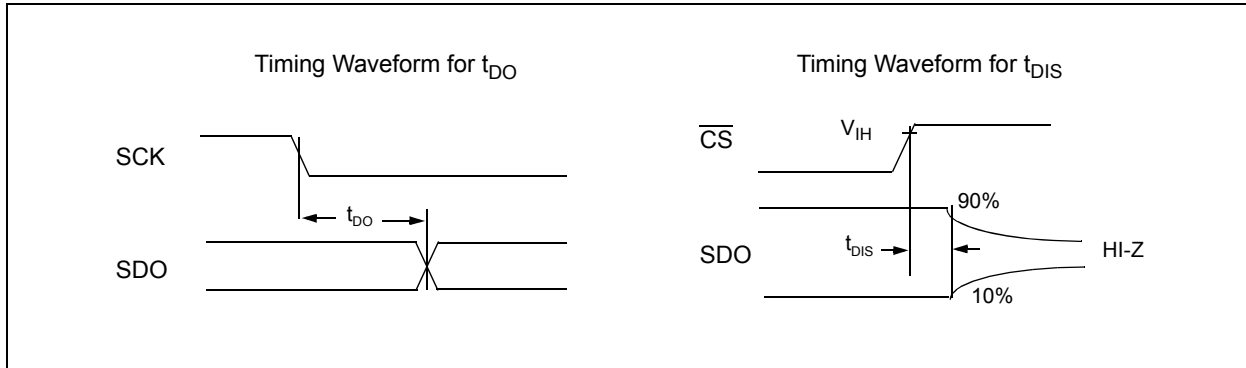


**FIGURE 29-22: DATA READY PULSE TIMING DIAGRAM**



# PIC18F87J72

FIGURE 29-23: SPECIFIC TIMING DIAGRAMS

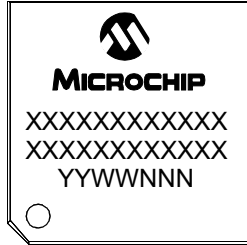




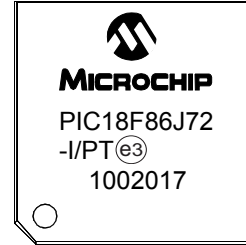
## 30.0 PACKAGING INFORMATION

### 30.1 Package Marking Information

80-Lead TQFP



Example



<b>Legend:</b>	XX...X	Customer-specific information
	Y	Year code (last digit of calendar year)
	YY	Year code (last 2 digits of calendar year)
	WW	Week code (week of January 1 is week '01')
	NNN	Alphanumeric traceability code
	(e3)	Pb-free JEDEC <sup>®</sup> designator for Matte Tin (Sn)
	*	This package is Pb-free. The Pb-free JEDEC <sup>®</sup> designator (e3) can be found on the outer packaging for this package.

**Note:** In the event the full Microchip part number cannot be marked on one line, it will be carried over to the next line, thus limiting the number of available characters for customer-specific information.

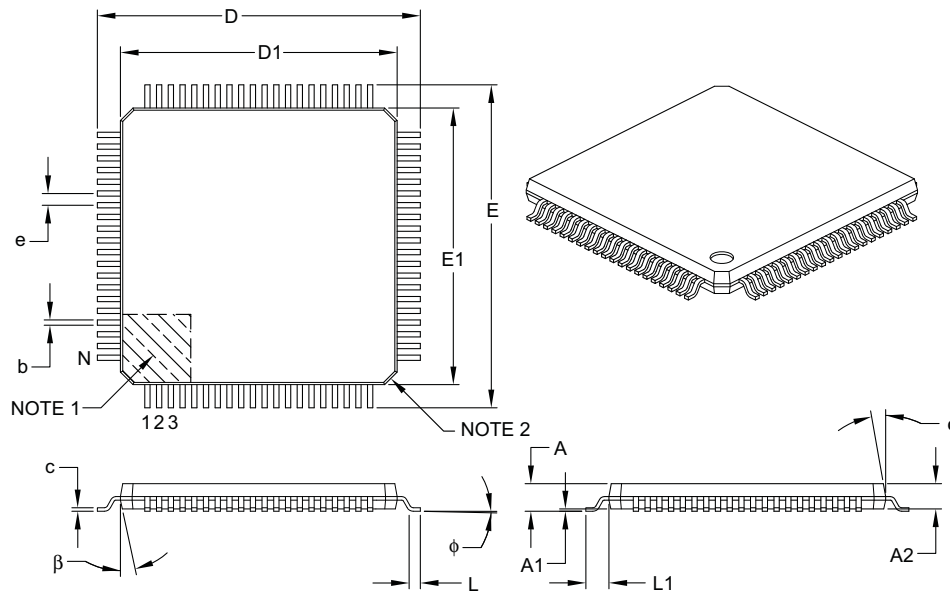
# PIC18F87J72

## 30.2 Package Details

The following sections give the technical details of the packages.

### 80-Lead Plastic Thin Quad Flatpack (PT) – 12x12x1 mm Body, 2.00 mm [TQFP]

**Note:** For the most current package drawings, please see the Microchip Packaging Specification located at <http://www.microchip.com/packaging>



Dimension Limits	Units	MILLIMETERS		
		MIN	NOM	MAX
Number of Leads	N	80		
Lead Pitch	e	0.50 BSC		
Overall Height	A	–	–	1.20
Molded Package Thickness	A2	0.95	1.00	1.05
Standoff	A1	0.05	–	0.15
Foot Length	L	0.45	0.60	0.75
Footprint	L1	1.00 REF		
Foot Angle	φ	0°	3.5°	7°
Overall Width	E	14.00 BSC		
Overall Length	D	14.00 BSC		
Molded Package Width	E1	12.00 BSC		
Molded Package Length	D1	12.00 BSC		
Lead Thickness	c	0.09	–	0.20
Lead Width	b	0.17	0.22	0.27
Mold Draft Angle Top	α	11°	12°	13°
Mold Draft Angle Bottom	β	11°	12°	13°

**Notes:**

- Pin 1 visual index feature may vary, but must be located within the hatched area.
- Chamfers at corners are optional; size may vary.
- Dimensions D1 and E1 do not include mold flash or protrusions. Mold flash or protrusions shall not exceed 0.25 mm per side.
- Dimensioning and tolerancing per ASME Y14.5M.

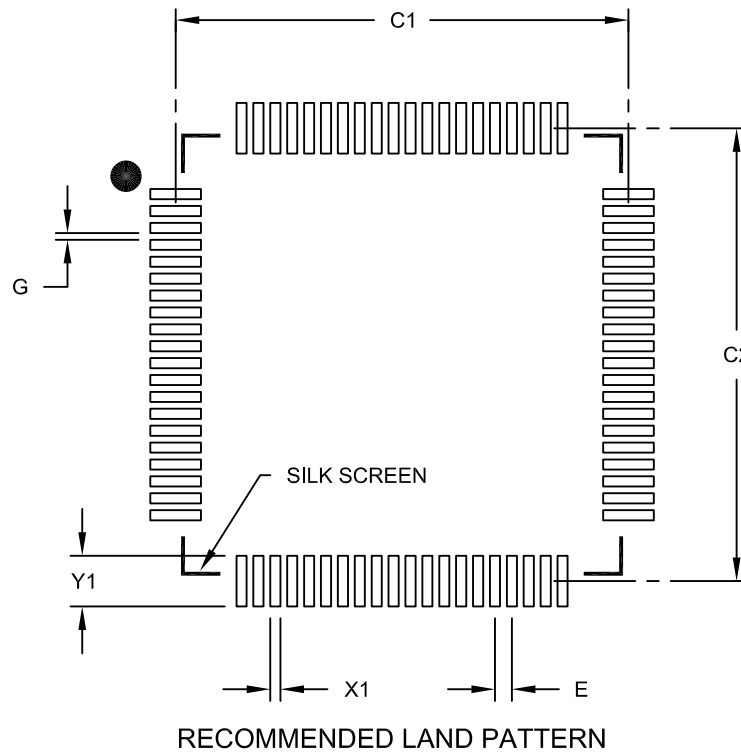
BSC: Basic Dimension. Theoretically exact value shown without tolerances.

REF: Reference Dimension, usually without tolerance, for information purposes only.

Microchip Technology Drawing C04-092B

## 80-Lead Plastic Thin Quad Flatpack (PT) - 12x12x1mm Body, 2.00 mm Footprint [TQFP]

**Note:** For the most current package drawings, please see the Microchip Packaging Specification located at <http://www.microchip.com/packaging>



Dimension Limits	Units	MILLIMETERS		
		MIN	NOM	MAX
Contact Pitch	E		0.50 BSC	
Contact Pad Spacing	C1		13.40	
Contact Pad Spacing	C2		13.40	
Contact Pad Width (X80)	X1			0.30
Contact Pad Length (X80)	Y1			1.50
Distance Between Pads	G	0.20		

**Notes:**

1. Dimensioning and tolerancing per ASME Y14.5M

BSC: Basic Dimension. Theoretically exact value shown without tolerances.

Microchip Technology Drawing No. C04-2092B

# PIC18F87J72

---

## **APPENDIX A: REVISION HISTORY**

### **Revision A (June 2010)**

Original data sheet for the PIC18F87J72 family devices.

### **Revision B (9/2016)**

Removed Preliminary from the data sheet; Other minor corrections.

## APPENDIX B: DUAL-CHANNEL, 24-BIT AFE REFERENCE

### B.1 Introduction

#### B.1.1 DESCRIPTION

The dual-channel Analog Front End (AFE) contains two synchronous sampling Delta-Sigma Analog-to-Digital Converters (ADC), two PGAs, phase delay compensation block, internal voltage reference, modulator output block and high-speed 20 MHz SPI compatible serial interface. The converters contain a proprietary dithering algorithm for reduced Idle tones and improved THD.

The internal register map contains 24-bit wide ADC data words, as well as six writable control registers to program gain, oversampling ratio, phase, resolution, dithering, shutdown, Reset and communication features. The communication is largely simplified with various continuous read modes that can be accessed by the DMA of an external device, and with a separate Data Ready (DR) pin that can directly be connected to an IRQ input of an external microcontroller.

The AFE is capable of interfacing to a large variety of voltage and current sensors, including shunts, current transformers, Rogowski coils and Hall effect sensors.

#### B.1.2 DELTA-SIGMA ADC ARCHITECTURE

The AFE incorporates two Delta-Sigma ADCs with a multi-bit architecture. A Delta-Sigma ADC is an oversampling converter that incorporates a built-in modulator which is digitizing the quantity of charge integrated by the modulator loop. The quantizer is the block that is performing the analog-to-digital conversion. The quantizer is typically 1-bit or a simple comparator which helps to maintain the linearity performance of the ADC (the DAC structure is in this case inherently linear).

Multi-bit quantizers help to lower the quantization error (the error fed back in the loop can be very large with 1-bit quantizers) without changing the order of the modulator or the OSR which leads to better SNR figures. However, typically, the linearity of such architectures is more difficult to achieve since the DAC is no more simple to realize and its linearity limits the THD of such ADCs.

The 5-level quantizer is a Flash ADC composed of 4 comparators, arranged with equally spaced thresholds and a thermometer coding. The AFE also includes proprietary, 5-level DAC architecture that is inherently linear for improved THD figures.

#### B.1.3 FEATURES

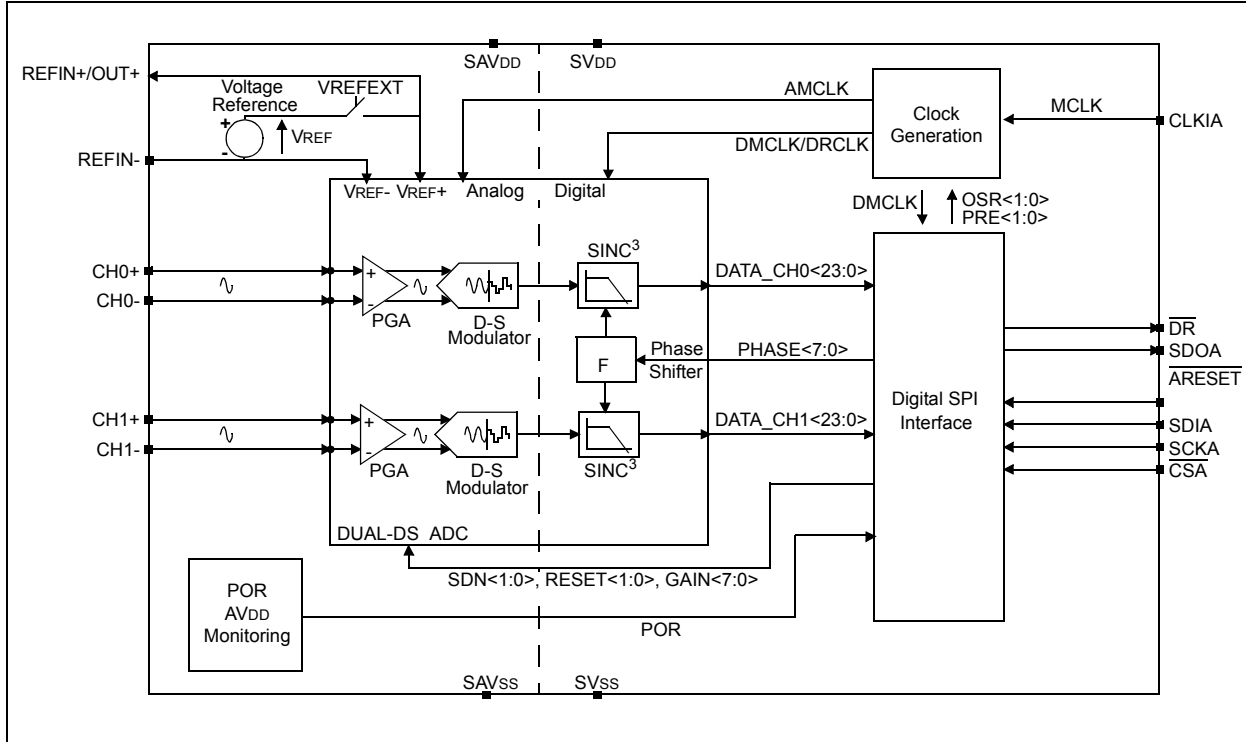
- Two synchronous sampling 16/24-bit resolution Delta-Sigma A/D Converters with proprietary multi-bit architecture
- 91 dB SINAD, -104 dBc THD (up to 35<sup>th</sup> harmonic), 109 dB SFDR for each channel
- Programmable data rate of up to 64 kbps
- Ultra Low-Power Shutdown mode with <2  $\mu$ A
- -133 dB crosstalk between the two channels
- Low drift internal voltage reference: 12 ppm/ $^{\circ}$ C
- Differential voltage reference input pins
- High gain PGA on each channel (up to 32V/V)
- Phase delay compensation between the two channels with 1  $\mu$ s time resolution
- Separate modulator outputs for each channel
- High-speed addressable 20 MHz SPI interface with Mode 0,0 and 1,1 compatibility
- Independent analog and digital power supplies 4.5V-5.5V SAVDD, 2.7V-5.5V SVDD
- Low-power consumption (14 mW typical at 5V)

#### B.1.4 APPLICATIONS

- Energy Metering and Power Measurement
- Automotive
- Portable Instrumentation
- Medical and Power Monitoring

# PIC18F87J72

FIGURE B-1: DUAL-CHANNEL AFE FUNCTIONAL BLOCK DIAGRAM



## B.2 Pin Description

### B.2.1 AFE RESET ( $\overline{\text{ARESET}}$ )

This pin is active-low and places the AFE in a Reset state when active.

When  $\overline{\text{ARESET}} = 0$ , all registers are reset to their default value, no communication can take place and no clock is distributed to internal circuitry. This state is equivalent to a POR state.

Since the default state of the ADCs is on, the analog power consumption when  $\overline{\text{ARESET}} = 0$  is equivalent to when  $\overline{\text{ARESET}} = 1$ . Only the digital power consumption is largely reduced because this current consumption is essentially dynamic and is reduced drastically when there is no clock running.

All the analog biases are enabled during a Reset, so that the part is fully operational just after a  $\overline{\text{ARESET}}$  rising edge.

This input is Schmitt triggered.

### B.2.2 DIGITAL VDD (SVDD)

SVDD is the power supply pin for the AFE's digital circuitry. This pin requires appropriate bypass capacitors and should be maintained between 2.7V and 5.5V for specified operation.

### B.2.3 ANALOG VDD (SAVDD)

AVDD is the power supply pin for the AFE's analog circuitry. This pin requires appropriate bypass capacitors and should be maintained to  $5V \pm 10\%$  for specified operation.

### B.2.4 ADC DIFFERENTIAL ANALOG INPUTS (CHn+/CHn-)

CH0-/CH0+ and CH1-/CH1+ are the two fully differential, analog voltage inputs for the Delta-Sigma ADCs.

The linear and specified region of the channels are dependent on the PGA gain. This region corresponds to a differential voltage range of  $\pm 500 \text{ mV/GAIN}$  with  $V_{\text{REF}} = 2.4V$ .

The maximum absolute voltage, with respect to SAVss, for each CHn+/- input pin is  $\pm 1V$  with no distortion and  $\pm 6V$  with no breaking after continuous voltage.

### B.2.5 ANALOG GROUND (SAVss)

SAVss is the ground connection to internal analog circuitry (ADCs, PGA, voltage reference, POR). To ensure accuracy and noise cancellation, this pin must be connected to the same ground as SVss, preferably with a star connection. If an analog ground plane is available, it is recommended that this pin be tied to this plane of the PCB. This plane should also reference all other analog circuitry in the system.

### B.2.6 NON-INVERTING REFERENCE INPUT, INTERNAL REFERENCE OUTPUT (REFIN+/OUT)

This pin is the non-inverting side of the differential voltage reference input for both ADCs or the internal voltage reference output.

When  $V_{\text{REFEXT}} = 1$ , and an external voltage reference source can be used, the internal voltage reference is disabled. When using an external differential voltage reference, it should be connected to its VREF+ pin. When using an external single-ended reference, it should be connected to this pin.

When  $V_{\text{REFEXT}} = 0$ , the internal voltage reference is enabled and connected to this pin through a switch. This voltage reference has minimal drive capability, and thus, needs proper buffering and bypass capacitances (10  $\mu\text{F}$  tantalum in parallel with 0.1  $\mu\text{F}$  ceramic) if used as a voltage source.

For optimal performance, bypass capacitances should be connected between this pin and AGND at all times, even when the internal voltage reference is used. However, these capacitors are not mandatory to ensure proper operation.

### B.2.7 INVERTING REFERENCE INPUT (REFIN-)

This pin is the inverting side of the differential voltage reference input for both ADCs. When using an external differential voltage reference, it should be connected to its VREF- pin. When using an external, single-ended voltage reference, or when  $V_{\text{REFEXT}} = 0$  (default) and using the internal voltage reference, this pin should be directly connected to SAVss.

### B.2.8 DIGITAL GROUND CONNECTION (SVss)

SVss is the ground connection to internal digital circuitry (SINC filters, oscillator, serial interface). To ensure accuracy and noise cancellation, SVss must be connected to the same ground as SAVss, preferably with a star connection. If a digital ground plane is available, it is recommended that this pin be tied to this plane of the Printed Circuit Board (PCB). This plane should also reference all other digital circuitry in the system.

### B.2.9 DATA READY ( $\overline{\text{DR}}$ )

The Data Ready pin indicates if a new conversion result is ready to be read. The default state of this pin is high when  $\text{DR\_HIZN} = 1$  and is high impedance when  $\text{DR\_HIZN} = 0$  (default). After each conversion is finished, a low pulse will take place on the Data Ready pin to indicate the conversion result is ready as an interrupt. This pulse is synchronous with the master clock and has a defined and constant width.

# PIC18F87J72

---

The Data Ready pin is independent of the SPI interface and acts like an interrupt output. The pin state is not latched and the pulse width (and period) are both determined by the MCLK frequency, oversampling rate and internal clock prescale settings. The DR pulse width is equal to one DMCLK period and the frequency of the pulses is equal to DRCLK (see [Figure 29-22](#) in [Section 29.0 “Electrical Characteristics”](#) of the data sheet).

<b>Note:</b> This pin should not be left floating when the DR_HIZN bit is low; a 10 k $\Omega$ pull-up resistor connected to DVDD is recommended.
---

## B.2.10 MASTER CLOCK INPUT (CLKIA)

CLKIA provides the master clock for the device. The typical clock frequency specified is 4 MHz. However, the clock frequency can be 1 MHz to 5 MHz without disturbing ADC accuracy. With the current boost circuit enabled, the master clock can be used up to 8.192 MHz without disturbing ADC accuracy. Appropriate load capacitance should be connected to these pins for proper operation.

## B.2.11 CHIP SELECT ( $\overline{CSA}$ )

This pin is the SPI chip select that enables the serial communication. When this pin is high, no communication can take place. A chip select falling edge initiates the serial communication and a chip select rising edge terminates the communication. No communication can take place even when  $\overline{CSA}$  is low and when  $\overline{ARESET}$  is low.

This input is Schmitt triggered.

## B.2.12 SERIAL DATA CLOCK (SCKA)

This is the serial clock pin for SPI communication.

Data is clocked into the device on the rising edge of SCK. Data is clocked out of the device on the falling edge of SCK.

The AFE interface is compatible with both SPI 0,0 and 1,1 modes. SPI modes can only be changed during a Reset.

The maximum clock speed specified is 20 MHz when  $SV_{DD} > 4.5V$  and 10 MHz otherwise.

This input is Schmitt triggered.

## B.2.13 SERIAL DATA OUTPUT (SDOA)

This is the SPI data output pin. Data is clocked out of the device on the falling edge of SCK.

This pin stays high impedance during the first command byte. It also stays high-impedance during the whole communication for Write commands and when the  $\overline{CSA}$  pin is high or when the  $\overline{ARESET}$  pin is low. This pin is active only when a Read command is processed. Each read is processed by a packet of eight bits.

## B.2.14 SERIAL DATA INPUT (SDIA)

This is the SPI data input pin. Data is clocked into the device on the rising edge of SCK.

When  $\overline{CS}$  is low, this pin is used to communicate with series of 8-bit commands.

The interface is half-duplex (inputs and outputs do not happen at the same time).

Each communication starts with a chip select falling edge, followed by an 8-bit command word entered through the SDI pin. Each command is either a read or a Write command. Toggling SDI during a Read command has no effect.

This input is Schmitt triggered.



## B.3 Terminology and Formulas

This section defines the terms and formulas used throughout this data sheet. The following terms are defined:

- MCLK – Master Clock
- AMCLK – Analog Master Clock
- DMCLK – Digital Master Clock
- DRCLK – Data Rate Clock
- OSR – Oversampling Ratio
- Offset Error
- Gain Error
- Integral Non-Linearity Error
- Signal-To-Noise Ratio (SNR)
- Signal-To-Noise Ratio And Distortion (SINAD)
- Total Harmonic Distortion (THD)
- Spurious-Free Dynamic Range (SFDR)
- Idle Tones
- Dithering
- Crosstalk
- PSRR
- CMRR
- ADC Reset Mode
- Hard Reset Mode (ARESET = 0)
- ADC Shutdown Mode
- Full Shutdown Mode

### B.3.1 MCLK – MASTER CLOCK

This is the fastest clock present in the device. This is the frequency of the clock input at the CLKIA.

### B.3.2 AMCLK – ANALOG MASTER CLOCK

This is the clock frequency that is present on the analog portion of the device, after prescaling has occurred via the CONFIG1 PRESCALE<1:0> register bits. The analog portion includes the PGAs and the two sigma-delta modulators.

**EQUATION B-1: ANALOG MASTER CLOCK**

$$AMCLK = \frac{MCLK}{PRESCALE}$$

**TABLE B-1: OVERSAMPLING RATIO SETTINGS**

PRESCALE (CONFIG1<15:14>)		Analog Master Clock Prescale
0	0	AMCLK = MCLK/1 (default)
0	1	AMCLK = MCLK/2
1	0	AMCLK = MCLK/4
1	1	AMCLK = MCLK/8

### B.3.3 DMCLK – DIGITAL MASTER CLOCK

This is the clock frequency that is present on the digital portion of the device, after prescaling and division by 4. This is also the sampling frequency, that is the rate at which the modulator outputs are refreshed. Each period of this clock corresponds to one sample and one modulator output.

**EQUATION B-2: DIGITAL MASTER CLOCK**

$$DMCLK = \frac{AMCLK}{4} = \frac{MCLK}{4 \times PRESCALE}$$

### B.3.4 DRCLK – DATA RATE CLOCK

This is the output data rate (i.e., the rate at which the ADCs output new data). Each new data is signaled by a data ready pulse on the DR pin.

This data rate is depending on the OSR and the prescaler with the following formula:

**EQUATION B-3: DATA RATE CLOCK**

$$DRCLK = \frac{DMCLK}{OSR} = \frac{AMCLK}{4 \times OSR} = \frac{MCLK}{4 \times OSR \times PRESCALE}$$

Since this is the output data rate, and since the decimation filter is a SINC (or notch) filter, there is a notch in the filter transfer function at each integer multiple of this rate.

Table B-2 describes the various combinations of OSR and PRESCALE and their associated AMCLK, DMCLK and DRCLK rates.

### B.3.5 OSR – OVERSAMPLING RATIO

The ratio of the sampling frequency to the output data rate, OSR = DMCLK/DRCLK. The default OSR is 64, or with MCLK = 4 MHz, PRESCALE = 1, AMCLK = 4 MHz,  $f_S = 1$  MHz,  $f_D = 15.625$  ksp/s. The following bits in the CONFIG1 register are used to change the oversampling ratio (OSR).

**TABLE B-2: OVERSAMPLING RATIO SETTINGS**

CONFIG		OVERSAMPLING RATIO (OSR)
OSR<1:0>		
0	0	32
0	1	64 (default)
1	0	128
1	1	256

### B.3.6 OFFSET ERROR

This is the error induced by the ADC when the inputs are shorted together (VIN = 0V). The specification incorporates both PGA and ADC offset contributions.

# PIC18F87J72

This error varies with PGA and OSR settings. The offset is different on each channel and varies from chip to chip. This offset error can easily be calibrated out by a MCU with a subtraction. The offset is specified in mV.

The offset on the dual-channel AFE has a low temperature coefficient.

## B.3.7 GAIN ERROR

This is the error induced by the ADC on the slope of the transfer function. It is the deviation expressed in percent compared to the ideal transfer function defined by Equation B-15. The specification incorporates both PGA and ADC gain error contributions, but not the VREF contribution (it is measured with an external VREF). This error varies with PGA and OSR settings.

The gain error of the dual-channel AFE has a low temperature coefficient.

## B.3.8 INTEGRAL NON-LINEARITY ERROR

Integral nonlinearity error is the maximum deviation of an ADC transition point from the corresponding point of an ideal transfer function, with the offset and gain errors removed, or with the endpoints equal to zero.

It is the maximum remaining error after calibration of offset and gain errors for a DC input signal.

## B.3.9 SIGNAL-TO-NOISE RATIO (SNR)

For the AFE, the signal-to-noise ratio is a ratio of the output fundamental signal power to the noise power (not including the harmonics of the signal), when the input is a sine wave at a predetermined frequency. It is measured in dB. Usually, only the maximum signal to noise ratio is specified. The SNR figure depends mainly on the OSR and DITHER settings of the device.

### EQUATION B-4: SIGNAL-TO-NOISE RATIO

$$SNR(dB) = 10\log\left(\frac{SignalPower}{NoisePower}\right)$$

## B.3.10 SIGNAL-TO-NOISE RATIO AND DISTORTION (SINAD)

The most important figure of merit for the analog performance of the ADCs is the Signal-to-Noise and Distortion (SINAD) specification.

Signal-to-noise and distortion ratio is similar to signal-to-noise ratio, with the exception that you must include the harmonics power in the noise power calculation. The SINAD specification depends mainly on the OSR and DITHER settings.

### EQUATION B-5: SINAD EQUATION

$$SINAD(dB) = 10\log\left(\frac{SignalPower}{Noise + HarmonicsPower}\right)$$

The calculated combination of SNR and THD per the following formula also yields SINAD:

### EQUATION B-6: SINAD, THD AND SNR RELATIONSHIP

$$SINAD(dB) = 10\log\left[10^{\left(\frac{SNR}{10}\right)} + 10^{\left(\frac{-THD}{10}\right)}\right]$$

## B.3.11 TOTAL HARMONIC DISTORTION (THD)

The total harmonic distortion is the ratio of the output harmonics power to the fundamental signal power for a sine wave input and is defined by the following equation.

### EQUATION B-7: HARMONIC DISTORTION

$$THD(dB) = 10\log\left(\frac{HarmonicsPower}{FundamentalPower}\right)$$

The THD calculation includes the first 35 harmonics for the AFE's specifications. The THD is usually only measured with respect to the first 10 harmonics. This specification depends mainly on the DITHER setting.

THD is sometimes expressed in percentage. For converting the THD to a percentage, here is the formula:

### EQUATION B-8: PERCENTAGE THD

$$THD(\%) = 100 \times 10^{\frac{THD(dB)}{20}}$$

## B.3.12 SPURIOUS-FREE DYNAMIC RANGE (SFDR)

The ratio between the output power of the fundamental and the highest spur in the frequency spectrum. The spur frequency is not necessarily a harmonic of the fundamental even though it is usually the case. This figure represents the dynamic range of the ADC when a full-scale signal is used at the input. This specification depends mainly on the DITHER setting.

### EQUATION B-9: SPURIOUS-FREE DYNAMIC RANGE

$$SFDR(dB) = 10\log\left(\frac{FundamentalPower}{HighestSpurPower}\right)$$

## B.3.13 IDLE TONES

A Delta-Sigma Converter is an integrating converter. It also has a finite quantization step (LSB) which can be detected by its quantizer. A DC input voltage that is below the quantization step should only provide an all

zeros result, since the input is not large enough to be detected. As an integrating device, any Delta-Sigma will show, in this case, Idle tones. This means that the output will have spurs in the frequency content that are depending on the ratio between quantization step voltage and the input voltage. These spurs are the result of the integrated subquantization step inputs that will eventually cross the quantization steps after a long enough integration. This will induce an AC frequency at the output of the ADC and can be shown in the ADC output spectrum.

These Idle tones are residues that are inherent to the quantization process and the fact that the converter is integrating at all times without being reset. They are residues of the finite resolution of the conversion process. They are very difficult to attenuate and they are heavily signal dependent. They can degrade both SFDR and THD of the converter, even for DC inputs. They can be localized in the baseband of the converter, and thus, difficult to filter from the actual input signal.

For power metering applications, Idle tones can be very disturbing because energy can be detected even at the 50 or 60 Hz frequency, depending on the DC offset of the ADCs, while no power is really present at the inputs. The only practical way to suppress or attenuate Idle tones phenomenon is to apply dithering to the ADC. The Idle tones amplitudes are a function of the order of the modulator, the OSR and the number of levels in the quantizer of the modulator. A higher order, a higher OSR or a higher number of levels for the quantizer will attenuate the Idle tones amplitude.

## B.3.14 DITHERING

In order to suppress or attenuate the Idle tones present in any Delta-Sigma ADCs, dithering can be applied to the ADC. Dithering is the process of adding an error to the ADC feedback loop in order to “decorrelate” the outputs and “break” the Idle tones behavior. Usually a random or pseudo-random generator adds an analog or digital error to the feedback loop of the Delta-Sigma ADC in order to ensure that no tonal behavior can happen at its outputs. This error is filtered by the feedback loop and typically has a zero average value so that the converter static transfer function is not disturbed by the dithering process. However, the dithering process slightly increases the noise floor (it adds noise to the part) while reducing its tonal behavior, and thus, improving SFDR and THD.

The dithering process scrambles the Idle tones into baseband white noise and ensures that dynamic specs (SNR, SINAD, THD, SFDR) are less signal dependent. The AFE incorporates a proprietary dithering algorithm on both ADCs in order to remove Idle tones and improve THD, which is crucial for power metering applications.

## B.3.15 CROSSTALK

The crosstalk is defined as the perturbation caused by one ADC channel on the other ADC channel. It is a measurement of the isolation between the two ADCs present in the chip.

This measurement is a two-step procedure:

1. Measure one ADC input with no perturbation on the other ADC (ADC inputs shorted).
2. Measure the same ADC input with a perturbation sine wave signal on the other ADC at a certain predefined frequency.

The crosstalk is then the ratio between the output power of the ADC when the perturbation is present and when it is not divided by the power of the perturbation signal.

A lower crosstalk value implies more independence and isolation between the two channels.

The measurement of this signal is performed under the following conditions:

- GAIN = 1
- PRESCALE = 1
- OSR = 256
- MCLK = 4 MHz

# PIC18F87J72

## Step 1

- CH0+ = CH0- = SAVSS
- CH1+ = CH1- = SAVSS

## Step 2

- CH0+ = CH0- = SAVSS
- CH1+ – CH1- = 1VP-P @ 50/60 Hz (full-scale sine wave)

The crosstalk is then calculated with the following formula:

### EQUATION B-10:

$$CTalk(dB) = 10\log\left(\frac{\Delta CH0Power}{\Delta CH1Power}\right)$$

## B.3.16 PSRR

This is the ratio between a change in the power supply voltage and the ADC output codes. It measures the influence of the power supply voltage on the ADC outputs.

The PSRR specification can be DC (the power supply is taking multiple DC values) or AC (the power supply is a sine wave at a certain frequency with a certain common-mode). In AC, the amplitude of the sine wave is representing the change in the power supply.

It is defined as:

### EQUATION B-11:

$$PSRR(dB) = 20\log\left(\frac{\Delta V_{OUT}}{\Delta SAVDD}\right)$$

Where VOUT is the equivalent input voltage that the output code translates to with the ADC transfer function. For the AFE, SAVDD ranges from 4.5V to 5.5V, and for AC PSRR, a 50/60 Hz sine wave is chosen, centered around 5V, with a maximum 500 mV amplitude. The PSRR specification is measured with SAVDD = SVDD.

## B.3.17 CMRR

This is the ratio between a change in the common-mode input voltage and the ADC output codes. It measures the influence of the common-mode input voltage on the ADC outputs.

The CMRR specification can be DC (the common-mode input voltage is taking multiple DC values) or AC (the common-mode input voltage is a sine wave at a certain frequency with a certain common-mode). In AC, the amplitude of the sine wave is representing the change in the power supply.

It is defined as:

### EQUATION B-12: CMRR

$$CMRR(dB) = 20\log\left(\frac{\Delta V_{OUT}}{\Delta V_{CM}}\right)$$

When VCM = (CHn+ + CHn-)/2, the common-mode input voltage, and VOUT is the equivalent input voltage that is what the output code translates to with the ADC transfer function. For the AFE, VCM varies from -1V to +1V, and for the AC specification, a 50/60 Hz sine wave is chosen centered around 0V with a 500 mV amplitude.

## B.3.18 ADC RESET MODE

ADC Reset mode (also called Soft Reset mode) can only be entered through setting the RESET<1:0> bits high in the Configuration register. This mode is defined as the condition where the converters are active but their output is forced to '0'.

The registers are not affected in this Reset mode and retain their values.

The ADCs can immediately output meaningful codes after leaving Reset mode (and after the sinc filter settling time of 3/DRCLK). This mode is both entered and exited through the setting of the bits in the Configuration register.

Each converter can be placed in Soft Reset mode independently. The Configuration registers are not modified by the Soft Reset mode.

A data ready pulse will not be generated by any ADC while in Reset mode.

When an ADC exits ADC Reset mode, any phase delay present before Reset was entered will still be present. If one ADC was not in Reset, the ADC leaving Reset mode will automatically resynchronize the phase delay, relative to the other ADC channel, per the Phase Delay register block and give DR pulses accordingly.

If an ADC is placed in Reset mode while the other is converting, it is not shutting down the internal clock. When going back out of Reset, it will be resynchronized automatically with the clock that did not stop during Reset.

If both ADCs are in Soft Reset or Shutdown modes, the clock is no longer distributed to the digital core for low-power operation. Once any of the ADC is back to normal operation, the clock is automatically distributed again.

### B.3.19 HARD RESET MODE ( $\overline{\text{ARESET}} = 0$ )

This mode is only available during a POR or when the  $\overline{\text{ARESET}}$  pin is pulled low. The  $\overline{\text{ARESET}}$  pin low state places the device in a Hard Reset mode.

In this mode, all internal registers are reset to their default state.

The DC biases for the analog blocks are still active (i.e., the AFE is ready to convert). However, this pin clears all conversion data in the ADCs. The comparator outputs of both ADCs are forced to their Reset state ('0011'). The SINC filters are all reset as well as their double output buffers. See serial timing for minimum pulse low time in [Section 29.0 "Electrical Characteristics"](#) of the data sheet.

During a Hard Reset, no communication with the part is possible. The digital interface is maintained in a Reset state.

### B.3.20 ADC SHUTDOWN MODE

ADC Shutdown mode is defined as a state where the converters and their biases are off, consuming only leakage current. After this is removed, start-up delay time (SINC filter settling time will occur before outputting meaningful codes). The start-up delay is needed to power up all DC biases in the channel that were in shutdown. This delay is the same than  $t_{\text{POR}}$  and any  $\overline{\text{DR}}$  pulse coming within this delay should be discarded.

Each converter can be placed in Shutdown mode independently. The CONFIG registers are not modified by the Shutdown mode. This mode is only available through programming of the SHUTDOWN<1:0> bits in the CONFIG2 register.

The output data is flushed to all zeros while in ADC shutdown. No data ready pulses are generated by any ADC while in ADC Shutdown mode.

When an ADC exits ADC Shutdown mode, any phase delay present before shutdown was entered will still be present. If one ADC was not in shutdown, the ADC leaving Shutdown mode will resynchronize automatically the phase delay relative to the other ADC channel per the Phase Delay register block and give  $\overline{\text{DR}}$  pulses accordingly.

If an ADC is placed in Shutdown mode while the other is converting, it is not shutting down the internal clock. When going back out of shutdown, it will be resynchronized automatically with the clock that did not stop during Reset.

If both ADCs are in ADC Reset or ADC Shutdown modes, the clock is no more distributed to the digital core for low-power operation. Once any of the ADC is back to normal operation, the clock is automatically distributed again.

### B.3.21 FULL SHUTDOWN MODE

The lowest power consumption can be achieved when SHUTDOWN<1:0> = 11, VREFEXT = CLKEXT = 1. This mode is called "Full Shutdown mode" and no analog circuitry is enabled. In this mode, the POR SVDD monitoring circuit is also disabled. When the clock is Idle (CLKIA = 0 or 1 continuously), no clock is propagated throughout the chip. Both ADCs are in shutdown, the internal voltage reference is disabled and the internal oscillator is disabled.

The only circuit that remains active is the SPI interface, but this circuit does not induce any static power consumption. If SCK is Idle, the only current consumption comes from the leakage currents induced by the transistors and is less than 1  $\mu\text{A}$  on each power supply.

This mode can be used to power down the chip completely and avoid power consumption when there is no data to convert at the analog inputs. Any SCK or MCLK edge coming, while on this mode, will induce dynamic power consumption.

Once any of the SHUTDOWN, CLKEXT and VREFEXT bits returns to '0', the POR SVDD monitoring block is back to operation and SVDD monitoring can take place.

# PIC18F87J72

---

## B.4 Device Overview

### B.4.1 ANALOG INPUTS (CHn+/-)

The analog inputs of the dual-channel AFE can be connected directly to current and voltage transducers (such as shunts, current transformers or Rogowski coils). Each input pin is protected by specialized ESD structures that are certified to pass 7 kV HBM and 400V MM contact charge. These structures allow bipolar  $\pm 6V$  continuous voltage, with respect to SAVss, to be present at their inputs without the risk of permanent damage.

Both channels have fully differential voltage inputs for better noise performance. The absolute voltage at each pin relative to SAVss should be maintained in the  $\pm 1V$  range during operation in order to ensure the specified ADC accuracy. The common-mode signals should be adapted to respect both the previous conditions and the differential input voltage range. For best performance, the common-mode signals should be maintained to SAVss.

### B.4.2 PROGRAMMABLE GAIN AMPLIFIERS (PGA)

The two Programmable Gain Amplifiers (PGAs) reside at the front end of each Delta-Sigma ADC. They have two functions: translate the common-mode of the input from SAVss to an internal level between SAVss and SAVDD, and amplify the input differential signal. The translation of the common-mode does not change the differential signal, but re-centers the common-mode so that the input signal can be properly amplified.

The PGA block can be used to amplify very low signals, but the differential input range of the Delta-Sigma modulator must not be exceeded. The PGA is controlled by the PGA\_CHn<2:0> bits in the GAIN register. [Table B-3](#) represents the gain settings for the PGA:

**TABLE B-3: PGA CONFIGURATION SETTING**

PGA Gain (PGA_CHn<2:0>)			Gain		VIN Range (V)
			(V/V)	(dB)	
0	0	0	1	0	$\pm 0.5$
0	0	1	2	6	$\pm 0.25$
0	1	0	4	12	$\pm 0.125$
0	1	1	8	18	$\pm 0.0625$
1	0	0	16	24	$\pm 0.03125$
1	0	1	32	30	$\pm 0.015625$

## B.4.3 DELTA-SIGMA MODULATOR

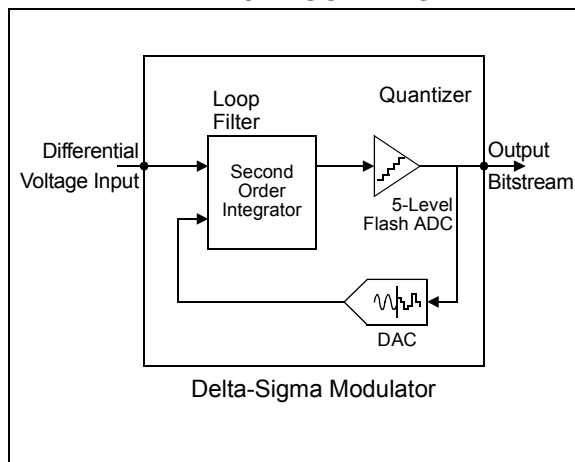
### B.4.3.1 Architecture

Both of the ADCs in the AFE are identical and they include a second-order modulator with a multi-bit DAC architecture (see [Figure B-2](#)). The quantizer is a Flash ADC composed of 4 comparators with equally spaced thresholds and a thermometer output coding. The proprietary 5-level architecture ensures minimum quantization noise at the outputs of the modulators without disturbing linearity or inducing additional distortion. The sampling frequency is DMCLK (typically 1 MHz with MCLK = 4 MHz) so the modulator outputs are refreshed at a DMCLK rate.

Both modulators also include a dithering algorithm that can be enabled through the DITHER<1:0> bits in the Configuration register. This dithering process improves THD and SFDR (for high OSR settings) while increasing slightly the noise floor of the ADCs. For power metering applications and applications that are distortion-sensitive, it is recommended to keep DITHER enabled for both ADCs. In the case of power metering applications, THD and SFDR are critical specifications to optimize SNR (noise floor). This is not really problematic due to the large averaging factor at the output of the ADCs; therefore, even for low OSR settings, the dithering algorithm will show a positive impact on the performance of the application.

[Figure B-2](#) represents a simplified block diagram of the Delta-Sigma ADC present on the AFE.

**FIGURE B-2: SIMPLIFIED DELTA-SIGMA ADC BLOCK DIAGRAM**



### B.4.3.2 Modulator Input Range and Saturation Point

For a specified voltage reference value of 2.4V, the modulators' specified differential input range is  $\pm 500$  mV. The input range is proportional to  $V_{REF}$  and scales according to the  $V_{REF}$  voltage. This range ensures the stability of the modulator over amplitude and frequency. Outside of this range, the modulator is still functional, however, its stability is no longer ensured, and therefore, it is not recommended to exceed this limit. The saturation point for the modulator is  $V_{REF}/3$  since the transfer function of the ADC includes a gain of 3 by default (independent from the PGA setting). See [Section B.4.5 "ADC Output Coding"](#).

### B.4.3.3 Boost Mode

The Delta-Sigma modulators also include an independent Boost mode for each channel. If the corresponding BOOST<1:0> bit is enabled, the power consumption of the modulator is multiplied by 2 and its bandwidth is increased to be able to sustain AMCLK clock frequencies, up to 8.192 MHz, while keeping the ADC accuracy. When disabled, the power consumption is back to normal and the AMCLK clock frequencies can only reach up to 5 MHz without affecting ADC accuracy.

### B.4.4 SINC<sup>3</sup> FILTER

Both of the ADCs include a decimation filter that is a third-order sinc (or notch) filter. This filter processes the multi-bit bitstream into 16 or 24-bit words (depending on the WIDTH Configuration bit). The settling time of the filter is 3 DMCLK periods. It is recommended to discard unsettled data to avoid data corruption, which can be done easily by setting the DR\_LTY bit high in the STATUS/COM register.

The resolution achievable at the output of the sinc filter (the output of the ADC) is dependant on the OSR and is summarized with the following table:

**TABLE B-4: ADC RESOLUTION vs. OSR**

OSR<1:0>		OSR	ADC Resolution (bits) No Missing Codes
0	0	32	17
0	1	64	20
1	0	128	23
1	1	256	24

For 24-Bit Output mode (WIDTH = 1), the output of the sinc filter is padded with least significant zeros for any resolution less than 24 bits.

For 16-Bit Output modes, the output of the sinc filter is rounded to the closest 16-bit number in order to conserve only 16-bit words and to minimize truncation error.

# PIC18F87J72

The gain of the transfer function of this filter is 1 at each multiple of DMCLK (typically 1 MHz), so a proper anti-aliasing filter must be placed at the inputs to attenuate the frequency content around DMCLK and keep the desired accuracy over the baseband of the converter. This anti-aliasing filter can be a simple first-order RC network with a sufficiently low time constant to generate high rejection at DMCLK frequency.

## EQUATION B-13: SINC FILTER TRANSFER FUNCTION $H(z)$

$$H(z) = \left( \frac{1 - z^{-OSR}}{OSR(1 - z^{-1})} \right)^3$$

where  $z = \exp\left(\frac{2\pi j f}{DMCLK}\right)$

The Normal-Mode Rejection Ratio (NMRR) or gain of the transfer function is given by the following equation:

## EQUATION B-14: MAGNITUDE OF FREQUENCY RESPONSE $H(f)$

$$NMRR(f) = \left| \frac{\text{sinc}\left(\pi \cdot \frac{f}{DMCLK}\right)}{\text{sinc}\left(\pi \cdot \frac{f}{DRCLK}\right)} \right|^3$$

or, 
$$NMRR(f) = \left| \frac{\text{sinc}\left(\pi \cdot \frac{f}{f_S}\right)}{\text{sinc}\left(\pi \cdot \frac{f}{f_D}\right)} \right|^3$$

where  $\text{sinc}(x) = \frac{\sin(x)}{x}$

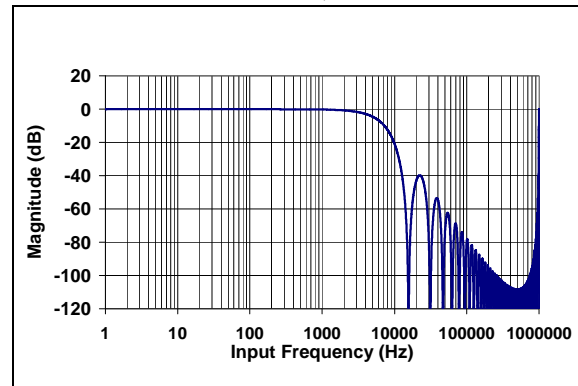
## EQUATION B-15:

$$DATA\_CHn = \left( \frac{CH_{n+} - CH_{n-}}{V_{REF+} - V_{REF-}} \right) \times 8,388,608 \times G \times 3 \quad \text{(For 24-bit Mode Or WIDTH = 1)}$$

$$DATA\_CHn = \left( \frac{CH_{n+} - CH_{n-}}{V_{REF+} - V_{REF-}} \right) \times 32,768 \times G \times 3 \quad \text{(For 16-bit Mode Or WIDTH = 0)}$$

Figure B-3 shows the sinc filter frequency response:

**FIGURE B-3: SINC FILTER RESPONSE WITH MCLK = 4 MHz, OSR = 64, PRESCALE = 1**



## B.4.5 ADC OUTPUT CODING

The second-order modulator, SINC<sup>3</sup> filter, PGA, VREF and analog input structure all work together to produce the device transfer function for the analog to digital conversion (see Equation B-15).

The channel data is either a 16-bit or 24-bit word, presented in 23-bit or 15-bit plus sign, two's complement format and is MSB (left) justified.

The ADC data is two or three bytes wide depending on the WIDTH bit of the associated channel. The 16-bit mode includes a round to the closest 16-bit word (instead of truncation) in order to improve the accuracy of the ADC data.

In case of positive saturation ( $CH_{n+} - CH_{n-} > V_{REF}/3$ ), the output is locked to 7FFFF for 24-bit mode (7FFF for 16-bit mode). In case of negative saturation ( $CH_{n+} - CH_{n-} \leq V_{REF}/3$ ), the output code is locked to 80000 for 24-bit mode (8000 for 16-bit mode).

Equation B-15 is only true for DC inputs. For AC inputs, this transfer function needs to be multiplied by the transfer function of the SINC<sup>3</sup> filter (see Equation B-13 and Equation B-14).



## B.4.5.1 ADC Resolution as a Function of OSR

The ADC resolution is a function of the OSR ([Section B.4.4 “SINC3 Filter”](#)). The resolution is the same for both channels. No matter what the resolution is, the ADC output data is always presented in 24-bit words, with added zeros at the end, if the OSR is not large enough to produce 24-bit resolution (left justification).

**TABLE B-5: OSR = 256 OUTPUT CODE EXAMPLES**

ADC Output Code (MSB First)	Hexadecimal	Decimal
0 1	0x7FFFFFFF	+ 8,388,607
0 1 0	0x7FFFFFFE	+ 8,388,606
0 0	0x000000	0
1 1	0xFFFFFFFF	-1
1 0 1	0x800001	- 8,388,607
1 0	0x800000	- 8,388,608

**TABLE B-6: OSR = 128 OUTPUT CODE EXAMPLES**

ADC Output Code (MSB First)	Hexadecimal	Decimal 23-Bit Resolution
0 1 1 1 1 1 1 1 1 1 1 1 1 1 1 1 1 1 1 0	0x7FFFFFFE	+ 4,194,303
0 1 1 1 1 1 1 1 1 1 1 1 1 1 1 0 1 1 1 1 1 1 0 0	0x7FFFFC	+ 4,194,302
0 0	0x000000	0
1 0	0xFFFFFE	-1
1 0 0 0 0 0 0 0 0 0 0 0 0 0 0 0 0 0 0 0 1 0	0x800002	- 4,194,303
1 0	0x800000	- 4,194,304

**TABLE B-7: OSR = 64 OUTPUT CODE EXAMPLES**

ADC Output Code (MSB First)	Hexadecimal	Decimal 20-Bit resolution
0 1 1 1 1 1 1 1 1 1 1 1 1 1 1 0 0 0 0 0	0x7FFFF0	+ 524, 287
0 1 1 1 1 1 1 1 1 1 1 1 1 1 1 0 0 0 0 0	0x7FFFE0	+ 524, 286
0 0 0 0 0 0 0 0 0 0 0 0 0 0 0 0 0 0 0 0	0x000000	0
1 1 1 1 1 1 1 1 1 1 1 1 1 1 1 0 0 0 0 0	0xFFFFF0	-1
1 0 0 0 0 0 0 0 0 0 0 0 0 0 0 1 0 0 0 0	0x800010	- 524,287
1 0 0 0 0 0 0 0 0 0 0 0 0 0 0 0 0 0 0 0	0x800000	- 524, 288

**TABLE B-8: OSR = 32 OUTPUT CODE EXAMPLES**

ADC Output Code (MSB First)	Hexadecimal	Decimal 17-Bit resolution
0 1 1 1 1 1 1 1 1 1 1 0 0 0 0 0 0 0 0	0x7FFF80	+ 65, 535
0 1 1 1 1 1 1 1 1 1 1 0 0 0 0 0 0 0 0	0x7FFF00	+ 65, 534
0 0 0 0 0 0 0 0 0 0 0 0 0 0 0 0 0 0 0 0	0x000000	0
1 1 1 1 1 1 1 1 1 1 1 0 0 0 0 0 0 0 0	0xFFFF80	-1
1 0 0 0 0 0 0 0 0 0 0 1 0 0 0 0 0 0 0 0	0x800080	- 65,535
1 0 0 0 0 0 0 0 0 0 0 0 0 0 0 0 0 0 0 0	0x800000	- 65, 536

# PIC18F87J72

## B.4.6 VOLTAGE REFERENCE

### B.4.6.1 Internal Voltage Reference

The AFE contains an internal voltage reference source specially designed to minimize drift over temperature. In order to enable the internal voltage reference, the VREFEXT bit in the Configuration register must be set to '0' (Default mode). This internal VREF supplies reference voltage to both channels. The typical value of this voltage reference is 2.37V  $\pm$ 2%. The internal reference has a very low typical temperature coefficient of  $\pm$ 12 ppm/ $^{\circ}$ C, allowing the output codes to have minimal variation with respect to temperature since they are proportional to (1/VREF).

The noise of the internal voltage reference is low enough not to significantly degrade the SNR of the ADC if compared to a precision external low-noise voltage reference.

The output pin for the internal voltage reference is REFIN+/OUT.

When the internal voltage reference is enabled, the REFIN- pin should always be connected to SAVss.

For optimal ADC accuracy, appropriate bypass capacitors should be placed between REFIN+/OUT and SAVss. Decoupling at the sampling frequency, around 1 MHz is important, for any noise around this frequency will be aliased back into the conversion data. 0.1  $\mu$ F ceramic and 10  $\mu$ F tantalum capacitors are recommended.

These bypass capacitors are not mandatory for correct ADC operation, but removing these capacitors may degrade accuracy of the ADC. The bypass capacitors also help for applications where the voltage reference output is connected to other circuits. In this case, additional buffering may be needed as the output drive capability of this output is low.

### B.4.6.2 Differential External Voltage Inputs

When the VREFEXT bit is high, the two reference pins (REFIN+/OUT, REFIN-) become a differential voltage reference input. The voltage at the REFIN+/OUT is noted VREF+ and the voltage at the REFIN- pin is noted VREF-. The differential voltage input value is given by the following equation:

$$V_{REF} = V_{REF+} - V_{REF-}$$

The specified VREF range is from 2.2V to 2.6V. The REFIN- pin voltage (VREF-) should be limited to  $\pm$ 0.3V. Typically, for single-ended reference applications, the REFIN- pin should be directly connected to SAVss.

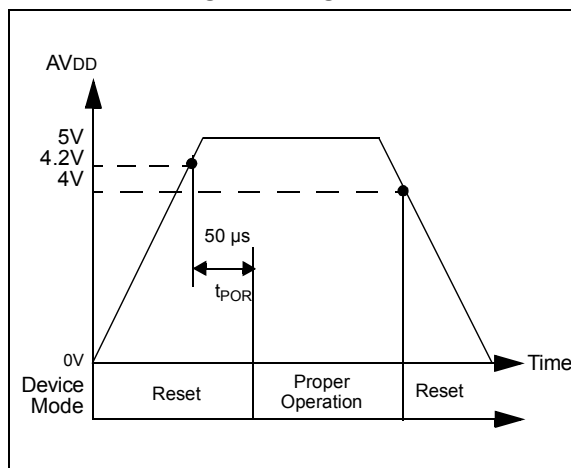
## B.4.7 POWER-ON RESET

The AFE contains its own internal POR circuit that monitors analog supply voltage AVDD during operation. The typical threshold for a power-up event detection is 4.2V,  $\pm$ 5%. The POR circuit has a built-in hysteresis for improved transient spikes immunity that has a typical value of 200 mV. Proper decoupling capacitors (0.1  $\mu$ F ceramic and 10  $\mu$ F tantalum) should be mounted as close as possible to the AVDD pin, providing additional transient immunity.

Figure B-4 illustrates the different conditions at power-up and a power-down event in the typical conditions. All internal DC biases are not settled until at least 50  $\mu$ s after system POR. Any DR pulses during this time after system Reset should be ignored. After POR,  $\overline{DR}$  pulses are present at the pin with all the default conditions in the Configuration registers.

The analog and digital power supplies are independent. Since AVDD is the only power supply that is monitored, it is highly recommended to power up DVDD first as a power-up sequence. If AVDD is powered up first, it is highly recommended to keep the  $\overline{RESET}$  pin low during the whole power-up sequence.

**FIGURE B-4: POWER-ON RESET OPERATION**



## B.4.8 $\overline{\text{ARESET}}$ EFFECT ON DELTA-SIGMA MODULATOR/SINC FILTER

When the  $\overline{\text{ARESET}}$  pin is low, both ADCs will be in Reset and output code, 0x0000h. The  $\overline{\text{RESET}}$  pin performs a Hard Reset (DC biases still on, part ready to convert) and clears all charges contained in the Sigma-Delta modulators. The comparator output is '0011' for each ADC.

The sinc filters are all reset, as well as their double output buffers. This pin is independent of the serial interface. It brings the CONFIG registers to the default state. When  $\overline{\text{RESET}}$  is low, any write with the SPI interface will be disabled and will have no effect. The output pins (SDOA,  $\overline{\text{DR}}$ ) are high impedance and no clock is propagated through the chip.

## B.4.9 PHASE DELAY BLOCK

The AFE incorporates a phase delay generator which ensures that the two ADCs are converting the inputs with a fixed delay between them. The two ADCs are synchronously sampling, but the averaging of modulator outputs is delayed so that the sinc filter outputs (thus, the ADC outputs) show a fixed phase delay, as determined by the PHASE register setting.

The PHASE register (PHASE<7:0>) is a 7-bit + sign, MSB first, two's complement register, that indicates how much phase delay there is to be between Channel 0 and Channel 1. The reference channel for the delay is Channel 1 (typically the voltage channel for power metering applications). When PHASE<7:0> bits are positive, Channel 0 is lagging versus Channel 1. When PHASE<7:0> are negative, Channel 0 is leading versus Channel 1. The amount of delay between two ADC conversions is given by the following formula:

### EQUATION B-16:

$$\text{Delay} = \frac{\text{Phase Register Code}}{\text{DMCLK}}$$

The timing resolution of the phase delay is 1/DMCLK or 1  $\mu\text{s}$  in the default configuration with MCLK = 4 MHz.

The data ready signals are affected by the phase delay settings. Typically, the time difference between the data ready pulses of Channel 0 and Channel 1 is equal to the phase delay setting.

**Note:** A detailed explanation of the Data Ready pin ( $\overline{\text{DR}}$ ) with phase delay is present in [Section B.5.9.1 "Data Ready Latches And Data Ready Modes \(DRMODE<1:0>\)"](#).

## B.4.9.1 Phase Delay Limits

The phase delay can only go from  $-\text{OSR}/2$  to  $+\text{OSR}/2 - 1$ . This sets the fine phase resolution. The PHASE register is coded with 2's complement.

If larger delays between the two channels are needed, they can be implemented by the microcontroller. A FIFO can save incoming data from the leading channel for a number N of DRCLK clocks. In this case, DRCLK would represent the coarse timing resolution, and DMCLK the fine timing resolution. The total delay will then be equal to:

$$\text{Delay} = N/\text{DRCLK} + \text{PHASE}/\text{DMCLK}$$

The Phase Delay register can be programmed once with the OSR = 256 setting, and will adjust to the OSR automatically afterwards, without the need to change the value of the PHASE register.

- **OSR = 256:** the delay can go from -128 to +127. PHASE<7> is the sign bit. PHASE<6> is the MSB and PHASE<0> is the LSB.
- **OSR = 128:** the delay can go from -64 to +63. PHASE<6> is the sign bit. PHASE<5> is the MSB and PHASE<0> is the LSB.
- **OSR = 64:** the delay can go from -32 to +31. PHASE<5> is the sign bit. PHASE<4> is the MSB and PHASE<0> is the LSB.
- **OSR = 32:** the delay can go from -16 to +15. PHASE<4> is the sign bit. PHASE<3> is the MSB and PHASE<0> is the LSB.

**TABLE B-9: PHASE VALUES WITH MCLK = 4 MHZ, OSR = 256**

PHASE Register Value								Delay (CH0 relative to CH1)	
Binary				Hex					
0	1	1	1	1	1	1	1	0x7F	+127 $\mu\text{s}$
0	1	1	1	1	1	1	0	0x7E	+126 $\mu\text{s}$
0	0	0	0	0	0	0	1	0x01	+1 $\mu\text{s}$
0	0	0	0	0	0	0	0	0x00	0 $\mu\text{s}$
1	1	1	1	1	1	1	1	0xFF	-1 $\mu\text{s}$
1	0	0	0	0	0	0	1	0x81	-127 $\mu\text{s}$
1	0	0	0	0	0	0	0	0x80	-128 $\mu\text{s}$

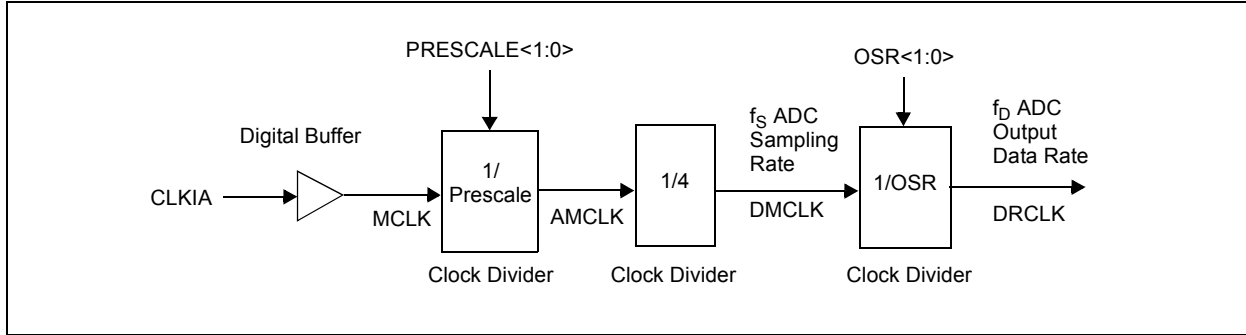
# PIC18F87J72

## B.4.10 INTERNAL AFE CLOCK

The AFE uses an external clock signal to operate its internal digital logic. An internal clock generation chain (Figure B-5) is used to produce a range of DRCLK sampling frequencies.

For keeping specified ADC accuracy, AMCLK should be kept between 1 and 5 MHz with BOOST off, or 1 and 8.192 MHz with BOOST on. Larger MCLK frequencies can be used provided the prescaler clock settings allow the AMCLK to respect these ranges.

**FIGURE B-5: AFE INTERNAL CLOCK DETAIL**



## B.5 Serial Interface Description

### B.5.1 OVERVIEW

The AFE is accessed for control and data output exclusively through its dedicated Serial Peripheral Interface (SPI). The interface is compatible with SPI Modes 0,0 and 1,1. Data is clocked out of the AFE on the falling edge of SCK, and data is clocked in on the rising edge of SCK. In these modes, SCK can Idle either high or low.

Each SPI communication starts with a  $\overline{CS}$  falling edge and stops with the  $\overline{CS}$  rising edge. Each SPI communication is independent. When  $\overline{CS}$  is high, SDO is in high-impedance, transitions on SCK and SDI have no effect. Additional control pins (ARESET and DR) are also provided on separate pins for advanced communication.

The AFE's SPI interface has a simple command structure. The first byte transmitted is always the control byte and is followed by data bytes that are 8-bit wide. Both ADCs are continuously converting data by default and can be reset or shut down through a CONFIG2 register setting.

Since each ADC data is either 16 or 24 bits (depending on the WIDTH bits), the internal registers can be grouped together with various configurations (through the READ bits) in order to allow easy data retrieval within only one communication. For device reads, the internal address counter can be automatically incremented in order to loop through groups of data within the register map. SDOA will then output the data located at the ADDRESS (A<4:0>) defined in the control byte and then ADDRESS + 1 depending on the READ<1:0> bits, which select the groups of registers. These groups are defined in Section B.6.1 "ADC Channel Data Output Registers" (Register Map).

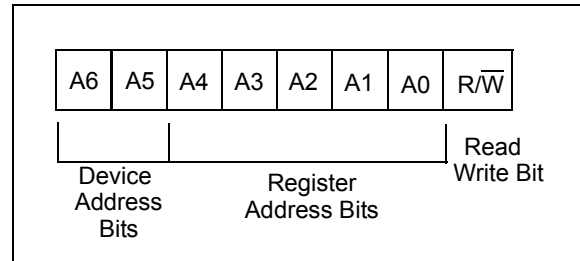
The Data Ready pin ( $\overline{DR}$ ) can be used as an interrupt for a microcontroller and outputs pulses when new ADC channel data is available. The ARESET pin acts like a Hard Reset and can reset the AFE to its default power-up configuration, independent of the microcontroller.

### B.5.2 CONTROL BYTE

The control byte of the AFE contains two device address bits (A<6:5>), five register address bits (A<4:0>) and a read/write bit (R/W). The first byte transmitted to the AFE is always the control byte.

The AFE interface is device-addressable (through A<6:5>) so that multiple devices can be present on the same SPI bus with no data bus contention. This functionality enables three-phase power metering systems containing an AFE and two other external AFE-type chips, controlled by a single SPI bus (single  $\overline{CS}$ , SCK, SDI and SDO pins). The default device address bits are '00'.

**FIGURE B-6: CONTROL BYTE**



A read on undefined addresses will give an all zeros output on the first and all subsequent transmitted bytes. A write on an undefined address will have no effect and will not increment the address counter either.

The register map is defined in Section B.6.1 "ADC Channel Data Output Registers".

## B.5.3 READING FROM THE DEVICE

The first data byte read is the one defined by the address given in the control byte. After this first byte is transmitted, if the CS pin is maintained low, the communication continues and the address of the next transmitted byte is determined by the status of the READ bits in the STATUS/COM register. Multiple looping configurations can be defined through the READ<1:0> bits for the address increment (see [Section B.5.6 "SPI Mode 0,0 - Clock Idle Low, Read/Write Examples"](#)).

## B.5.4 WRITING TO THE DEVICE

The first data byte written is the one defined by the address given in the control byte. The write communication automatically increments the address for subsequent bytes.

The address of the next transmitted byte within the same communication ( $\overline{\text{CS}}$  stays low) is the next address defined on the register map. At the end of the register map, the address loops to the beginning of the register map. Writing a non-writable register has no effect.

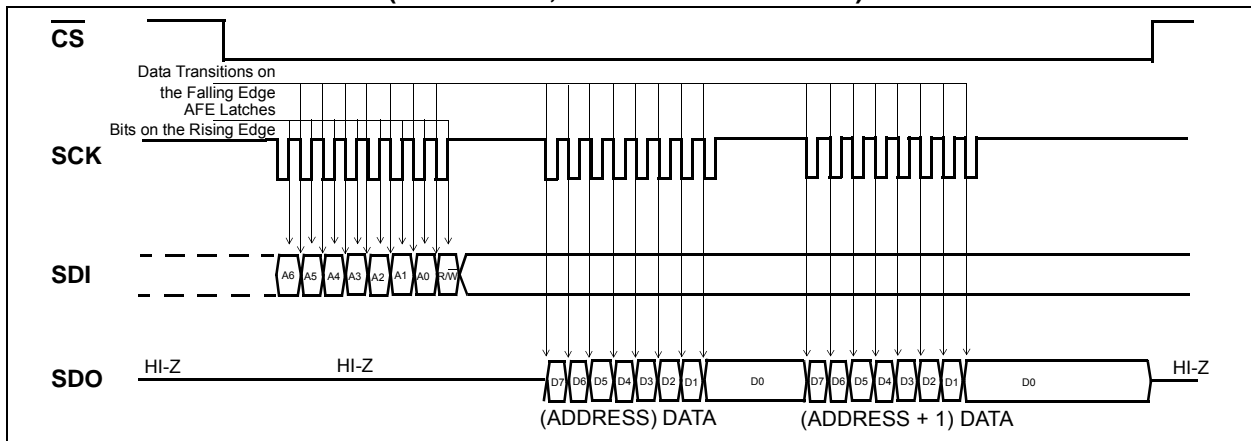
The SDOA pin stays in a high-impedance state during a write communication.

## B.5.5 SPI MODE 1,1 – CLOCK IDLE HIGH, READ/WRITE EXAMPLES

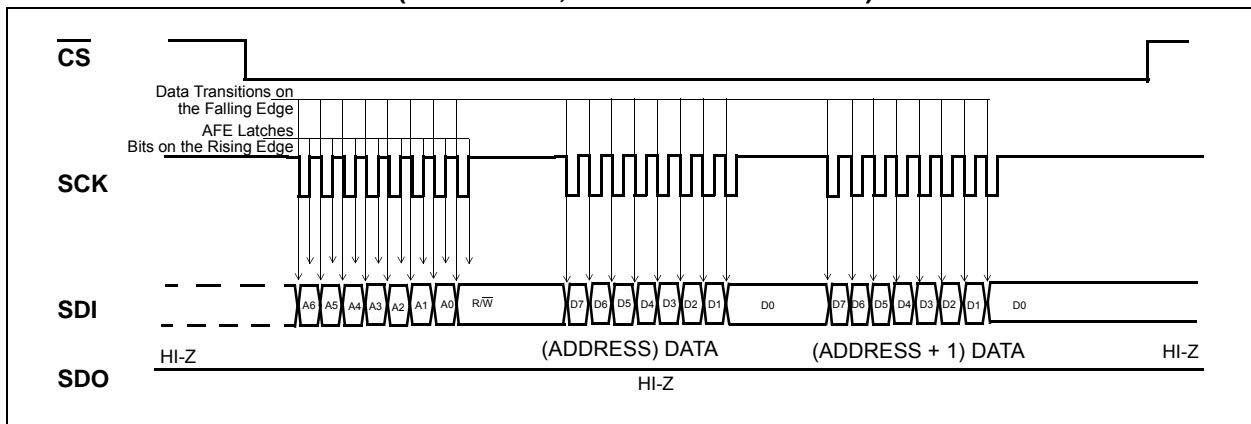
In this SPI mode, the clock Idles high. For the AFE, this means that there will be a falling edge before there is a rising edge.

**Note:** Changing from an SPI Mode 1,1 to an SPI Mode 0,0 is possible, but needs a Reset pulse in-between to ensure correct communication.

**FIGURE B-7: DEVICE READ (SPI MODE 1,1 – CLOCK IDLES HIGH)**



**FIGURE B-8: DEVICE WRITE (SPI MODE 1,1 – CLOCK IDLES HIGH)**

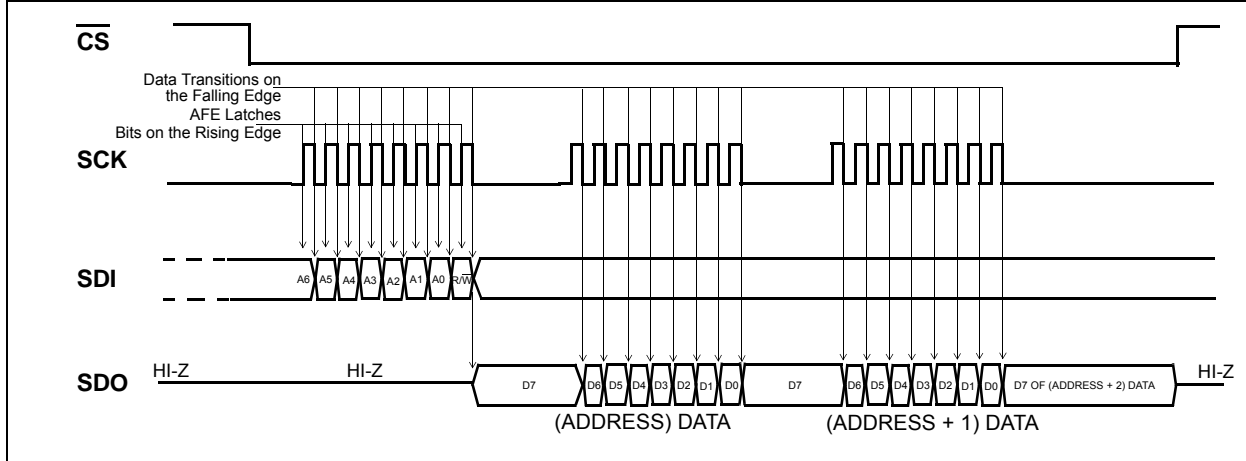


# PIC18F87J72

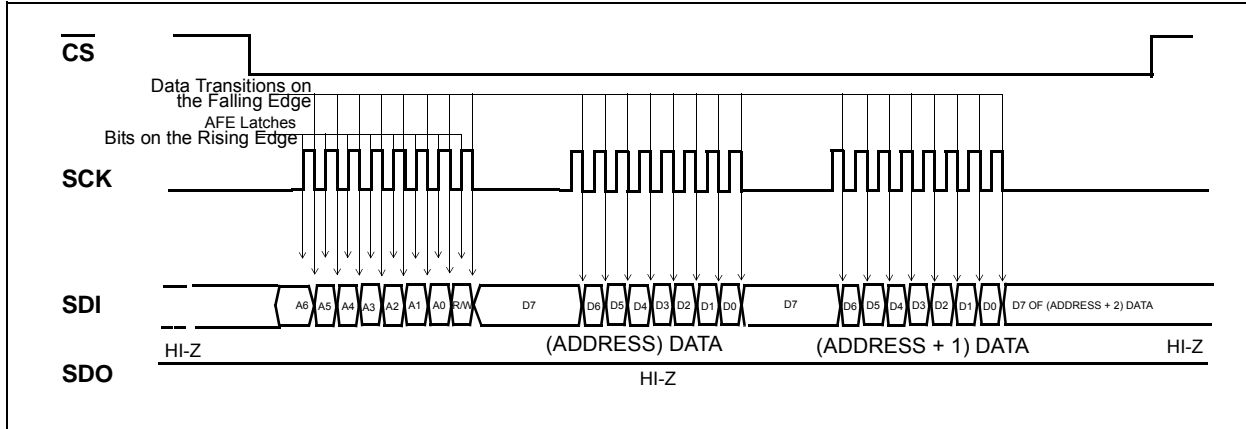
## B.5.6 SPI MODE 0,0 - CLOCK IDLE LOW, READ/WRITE EXAMPLES

In this SPI mode, the clock Idles low. For the AFE, this means that there will be a rising edge before there is a falling edge.

**FIGURE B-9: DEVICE READ (SPI MODE 0,0 – CLOCK IDLES LOW)**



**FIGURE B-10: DEVICE WRITE (SPI MODE 0,0 – CLOCK IDLES LOW)**



## B.5.7 CONTINUOUS COMMUNICATION, LOOPING ON ADDRESS SETS

If the user wishes to read back either of the ADC channels continuously, or both channels continuously, the internal address counter can be set to loop on specific register sets. In this case, there is only one control byte on SDI to start the communication. The part stays within the same loop until  $\overline{CS}$  returns high.

This internal address counter allows the following functionality:

- Read one ADC channel data continuously
- Read both ADC channel data continuously (both ADC data can be independent or linked with DRMODE settings)
- Read continuously the entire register map
- Read continuously each separate register
- Read continuously all Configuration registers
- Write all Configuration registers in one communication (see [Figure B-11](#))

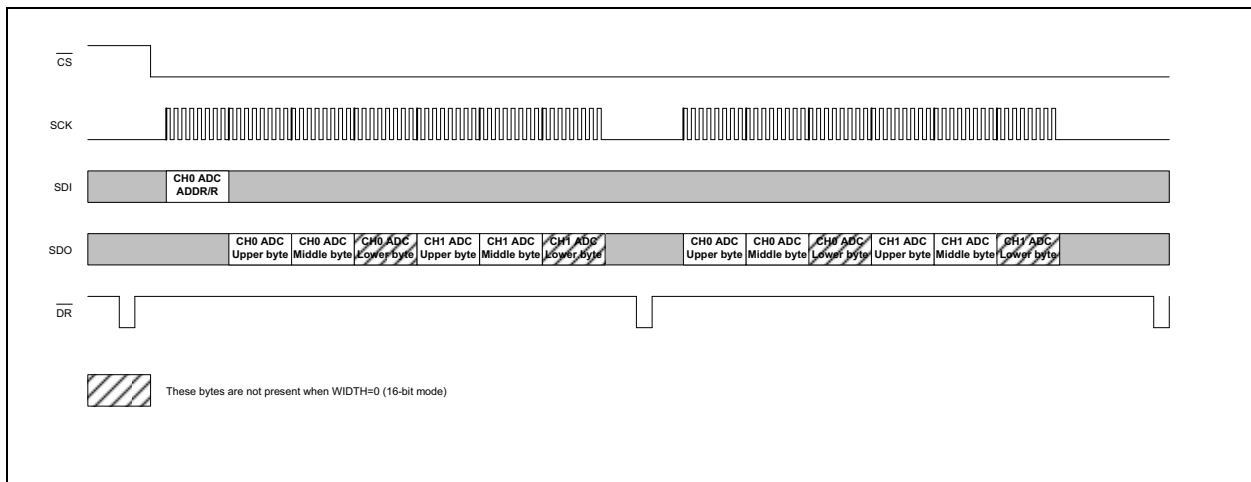
The STATUS/COM register contains the loop settings for the internal address counter (READ<1:0>). The internal address counter can either stay constant (READ<1:0> = 00) and read continuously the same byte, or it can auto-increment and loop through the register groups defined below (READ<1:0> = 01), register types (READ<1:0> = 10) or the entire register map (READ<1:0> = 11).

Each channel is configured independently as either a 16-bit or 24-bit data word depending on the setting of the corresponding WIDTH bit in the CONFIG1 register.

For continuous reading, in the case of WIDTH = 0 (16-bit), the lower byte of the ADC data is not accessed and the part jumps automatically to the following address (the user does not have to clock out the lower byte since it becomes undefined for WIDTH = 0).

The following figure represents a typical, continuous read communication with the default settings (DRMODE<1:0> = 00, READ<1:0> = 10) for both width settings. This configuration is typically used for power metering applications.

**FIGURE B-11: TYPICAL CONTINUOUS READ COMMUNICATION**



# PIC18F87J72

## B.5.7.1 Continuous Write

Both ADCs are powered up with their default configurations and begin to output  $\overline{DR}$  pulses immediately (RESET<1:0> and SHUTDOWN<1:0> bits are all '0' by default).

The default output codes for both ADCs are all zeros. The default modulator output for both ADCs is '0011' (corresponding to a theoretical zero voltage at the inputs). The default phase is zero between the two channels.

It is recommended to enter into ADC Reset mode for both ADCs just after power-up because the desired register configuration may not be the default one, and in this case, the ADC would output undesired data. Within the ADC Reset mode (RESET<1:0> = 11), the user can configure the whole part with a single communication. The Write commands increment the address automatically so that the user can start writing the PHASE register, and finish with the CONFIG2 register, in only one communication (see Figure B-11). The RESET<1:0> bits are in the CONFIG2 register to allow exiting of the Soft Reset mode, and have the whole part configured and ready to run in only one command.

The following register sets are defined as groups:

**TABLE B-10: REGISTER GROUPS**

GROUP	ADDRESSES
ADC DATA CH0	0x00-0x02
ADC DATA CH1	0x03-0x05
PHASE, GAIN	0x07-0x08
CONFIG, STATUS	0x09-0x0B

The following register sets are defined as types:

**TABLE B-11: REGISTER TYPES**

TYPE	ADDRESSES
ADC DATA (Both Channels)	0x00-x05
CONFIGURATION	0x07-0x0B

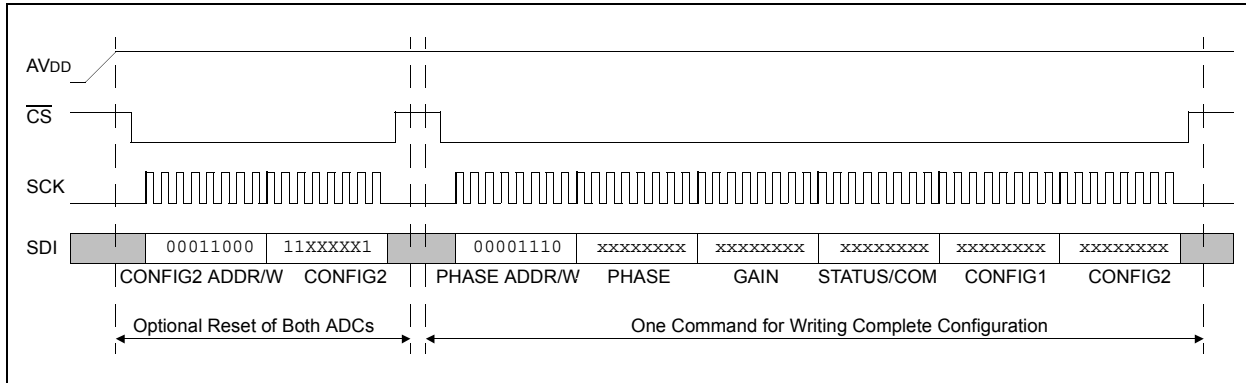
## B.5.8 SITUATIONS THAT RESET ADC DATA

Immediately after the following actions, the ADCs are temporarily reset in order to provide proper operation:

1. Change in the PHASE register.
2. Change in the OSR setting.
3. Change in the PRESCALE setting.
4. Overwrite of the same PHASE register value.
5. Change in the CLKEXT bit in the CONFIG2 register, modifying the internal oscillator state.

After these temporary Resets, the ADCs go back to the normal operation with no need for an additional command. These are also the settings where the  $\overline{DR}$  position is affected. The PHASE register can be used to serially soft reset the ADCs without using the RESET bits in the Configuration register if the same value is written in the PHASE register.

**FIGURE B-12: RECOMMENDED CONFIGURATION SEQUENCE AT POWER UP**





## B.5.9 DATA READY PIN ( $\overline{\text{DR}}$ )

To signify when channel data is ready for transmission, the data ready signal is available on the Data Ready pin ( $\overline{\text{DR}}$ ) through an active-low pulse at the end of a channel conversion.

The Data Ready pin outputs an active-low pulse with a period that is equal to the  $\text{DRCLK}$  clock period and with a width equal to one  $\text{DMCLK}$  period.

When not active-low, this pin can either be in high impedance (when  $\text{DR\_HIZN} = 0$ ) or in a defined logic high state (when  $\text{DR\_HIZN} = 1$ ). This is controlled through the Configuration registers. This allows multiple devices to share the same Data Ready pin (with a pull-up resistor connected between  $\overline{\text{DR}}$  and  $\text{DVDD}$ ) in 3-phase energy meter designs to reduce microcontroller pin count. A single device on the bus does not require a pull-up resistor.

After a data ready pulse has occurred, the ADC output data can be read through SPI communication. Two sets of latches at the output of the ADC prevent the communication from outputting corrupted data (see [Section B.5.9.1 “Data Ready Latches And Data Ready Modes \( \$\text{DRMODE}<1:0>\$ \)”](#)).

The  $\overline{\text{CS}}$  pin has no effect on the  $\overline{\text{DR}}$  pin, which means even if  $\overline{\text{CS}}$  is high, data ready pulses will be provided (except when the configuration prevents from outputting data ready pulses). The  $\overline{\text{DR}}$  pin can be used as an interrupt when connected to an external microcontroller. When the  $\overline{\text{ARESET}}$  pin is low, the  $\overline{\text{DR}}$  pin is not active.

### B.5.9.1 Data Ready Latches And Data Ready Modes ( $\text{DRMODE}<1:0>$ )

To ensure that both channel ADC data are present at the same time for SPI read, regardless of phase delay settings for either or both channels, there are two sets of latches in series with both the data ready and the ‘read start’ triggers.

The first set of latches holds each output when data is ready and latches both outputs together when  $\text{DRMODE}<1:0> = 00$ . When this mode is on, both ADCs work together and produce one set of available data after each data ready pulse (that corresponds to the lagging ADC data ready). The second set of latches ensures that when reading starts on an ADC output, the corresponding data is latched so that no data corruption can occur.

If an ADC read has started, in order to read the following ADC output, the current reading needs to be completed (all bits must be read from the ADC output data registers).

### B.5.9.2 Data Ready Pin ( $\overline{\text{DR}}$ ) Control Using $\text{DRMODE}$ Bits

There are four modes that control the data ready pulses and these modes are set with the  $\text{DRMODE}<1:0>$  bits in the  $\text{STATUS/COM}$  register. For power metering applications,  $\text{DRMODE}<1:0> = 00$  is recommended (Default mode).

The position of  $\overline{\text{DR}}$  pulses vary with respect to this mode, to the  $\text{OSR}$  and to the  $\text{PHASE}$  settings:

- **$\text{DRMODE}<1:0> = 11$ :** Both Data Ready pulses from ADC Channel 0 and ADC Channel 1 are output on the  $\overline{\text{DR}}$  pin.
- **$\text{DRMODE}<1:0> = 10$ :** Data Ready pulses from ADC Channel 1 are output on the  $\overline{\text{DR}}$  pin.  $\overline{\text{DR}}$  pulses from ADC Channel 0 are not present on the pin.
- **$\text{DRMODE}<1:0> = 01$ :** Data Ready pulses from ADC Channel 0 are output on the  $\overline{\text{DR}}$  pin.  $\overline{\text{DR}}$  pulses from ADC Channel 1 are not present on the pin.
- **$\text{DRMODE}<1:0> = 00$ :** (Recommended and Default mode). Data Ready pulses from the lagging ADC, between the two, are output on the  $\overline{\text{DR}}$  pin. The lagging ADC depends on the  $\text{PHASE}$  register and on the  $\text{OSR}$ . In this mode, the two ADCs are linked together so their data is latched together when the lagging ADC output is ready.

### B.5.9.3 $\overline{\text{DR}}$ Pulses with Shutdown or Reset Conditions

There will be no  $\overline{\text{DR}}$  pulses if  $\text{DRMODE}<1:0> = 00$  when either one or both of the ADCs are in Reset or Shutdown. In Mode 00, a  $\overline{\text{DR}}$  pulse only happens when both ADCs are ready. Any  $\overline{\text{DR}}$  pulse will correspond to one data on both ADCs. The two ADCs are linked together and act as if there was only one channel with the combined data of both ADCs. This mode is very practical when both ADC channel data retrieval and processing need to be synchronized, as in power metering applications.

**Note:** If  $\text{DRMODE}<1:0> = 11$ , the user will still be able to retrieve the  $\overline{\text{DR}}$  pulse for the ADC not in shutdown or Reset (i.e., only one ADC channel needs to be awake).

[Figure B-13](#) represents the behavior of the Data Ready pin with the different  $\text{DRMODE}$  and  $\text{DR\_LTY}$  configurations, while shutdown or Resets are applied.



## B.6 Internal Registers

The addresses associated with the internal registers are listed below. A detailed description of the registers follows. All registers are eight bits long and can be addressed separately. Read modes define the groups and types of registers for continuous read communication or looping on address sets.

**TABLE B-12: REGISTER MAP**

Address	Name	Bits	R/W	Description
0x00	DATA_CH0	24	R	Channel 0 ADC Data<23:0>, MSB First
0x03	DATA_CH1	24	R	Channel 1 ADC Data<23:0>, MSB First
0x06	reserved	8	—	Reserved; Ignore Reads, Do Not Write
0x07	PHASE	8	R/W	Phase Delay Configuration Register
0x08	GAIN	8	R/W	Gain Configuration Register
0x09	STATUS/COM	8	R/W	Status/Communication Register
0x0A	CONFIG1	8	R/W	Configuration Register 1
0x0B	CONFIG2	8	R/W	Configuration Register 2

**TABLE B-13: REGISTER MAP GROUPING FOR CONTINUOUS READ MODES**

Function	Address	READ<1:0>		
		"01"	"10"	"11"
DATA_CH0	0x00	GROUP	TYPE	Loop Entire Register Map
	0x01			
	0x02			
DATA_CH1	0x03	GROUP	TYPE	
	0x04			
	0x05			
PHASE	0x07	GROUP	TYPE	
GAIN	0x08			
STATUS/COM	0x09	GROUP	TYPE	
CONFIG1	0x0A			
CONFIG2	0x0B			

# PIC18F87J72

## B.6.1 ADC CHANNEL DATA OUTPUT REGISTERS

The ADC Channel Data Output registers always contain the most recent A/D conversion data for each channel. These registers are read-only. They can be accessed independently as three 8-bit registers or linked together (with READ<1:0> bits).

These registers are latched when an ADC read communication occurs. When a data ready event occurs during a read communication, the most current ADC data is also latched to avoid data corruption issues.

The three bytes of each channel are updated synchronously at a DRCLK rate. The three bytes can be accessed separately if needed but are refreshed synchronously.

### REGISTER B-1: DATA\_CHn: CHANNEL OUTPUT REGISTERS (CH0, ADDRESSES 0x00-0x02; CH1; 0x03-0x05)

R-0	R-0	R-0	R-0	R-0	R-0	R-0	R-0
DATA_CHn <23>	DATA_CHn <22>	DATA_CHn <21>	DATA_CHn <20>	DATA_CHn <19>	DATA_CHn <18>	DATA_CHn <17>	DATA_CHn <16>
bit 23							bit 16

R-0	R-0	R-0	R-0	R-0	R-0	R-0	R-0
DATA_CHn <15>	DATA_CHn <14>	DATA_CHn <13>	DATA_CHn <12>	DATA_CHn <11>	DATA_CHn <10>	DATA_CHn <9>	DATA_CHn <8>
bit 15							bit 8

R-0	R-0	R-0	R-0	R-0	R-0	R-0	R-0
DATA_CHn <7>	DATA_CHn <6>	DATA_CHn <5>	DATA_CHn <4>	DATA_CHn <3>	DATA_CHn <2>	DATA_CHn <1>	DATA_CHn <0>
bit 7							bit 0

#### Legend:

R = Readable bit  
-n = Value at POR

W = Writable bit  
'1' = Bit is set

U = Unimplemented bit, read as '0'  
'0' = Bit is cleared

x = Bit is unknown

## B.6.2 PHASE REGISTER

The PHASE register (PHASE<7:0>) is a 7 bits + sign, MSB first, two's complement register that indicates how much phase delay there should be between Channel 0 and Channel 1.

The reference channel for the delay is Channel 1 (typically, the voltage channel when used in energy metering applications) i.e., when PHASE register code is positive, Channel 0 is lagging Channel 1.

When PHASE register code is negative, Channel 0 is leading versus Channel 1.

The delay is give by the following formula:

### EQUATION B-17:

$$Delay = \frac{Phase\ Register\ Code}{DMCLK}$$

### B.6.2.1 Phase Resolution from OSR

The timing resolution of the phase delay is 1/DMCLK or 1 μs in the default configuration (MCLK = 4 MHz). The PHASE register coding depends on the OSR setting, as shown in Table B-14.

**TABLE B-14: PHASE ENCODING RESOLUTION BY OVERSAMPLING RATIO**

Oversampling Ratio		Encoding		
OSR <1:0>	Value	# Significant Digits	Sign Bit	Range
00	32	7 <6:0>	<7>	-128 to +127
01	64	6 <5:0>	<6>	-64 to +63
10	128	5 <4:0>	<5>	-32 to +31
11	256	4 <3:0>	<4>	-16 to +15

### REGISTER B-2: PHASE: PHASE REGISTER (ADDRESS 0x07)

R/W-0	R/W-0	R/W-0	R/W-0	R/W-0	R/W-0	R/W-0	R/W-0
PHASE<7>	PHASE<6>	PHASE<5>	PHASE<4>	PHASE<3>	PHASE<2>	PHASE<1>	PHASE<0>
bit 7							bit 0

#### Legend:

R = Readable bit                      W = Writable bit                      U = Unimplemented bit, read as '0'  
 -n = Value at POR                      '1' = Bit is set                      '0' = Bit is cleared                      x = Bit is unknown

bit 7-0                      **PHASE<7-0>**: CH0 Relative to CH1 Phase Delay bits  
 Delay = PHASE register two's complement code/DMCLK (Default PHASE = 0)

# PIC18F87J72

## B.6.3 GAIN CONFIGURATION REGISTER

This registers contains the settings for the PGA gains for each channel, as well as the BOOST options for each channel.

### REGISTER B-3: GAIN: GAIN CONFIGURATION REGISTER (ADDRESS 0x08)

R/W-0	R/W-0	R/W-0	R/W-0	R/W-0	R/W-0	R/W-0	R/W-0
PGA_CH1 <2>	PGA_CH1 <1>	PGA_CH1 <0>	BOOST<1>	BOOST<0>	PGA_CH0 <2>	PGA_CH0 <1>	PGA_CH0 <0>
bit 7							bit 0

#### Legend:

R = Readable bit	W = Writable bit	U = Unimplemented bit, read as '0'
-n = Value at POR	'1' = Bit is set	'0' = Bit is cleared      x = Bit is unknown

bit 7-5      **PGA\_CH1<2:0>**: PGA Setting for Channel 1 bits

111 = Reserved (Gain = 1)  
 110 = Reserved (Gain = 1)  
 101 = Gain is 32  
 100 = Gain is 16  
 011 = Gain is 8  
 010 = Gain is 4  
 001 = Gain is 2  
 000 = Gain is 1

bit 4-3      **BOOST<1:0>**: Current Scaling for High-Speed Operation bits

11 = Both channels have current x 2  
 10 = Channel 1 has current x 2  
 01 = Channel 0 has current x 2  
 00 = Neither channel has current x 2

bit 2-0      **PGA\_CH0<2:0>**: PGA Setting for Channel 0 bits

111 = Reserved (Gain = 1)  
 110 = Reserved (Gain = 1)  
 101 = Gain is 32  
 100 = Gain is 16  
 011 = Gain is 8  
 010 = Gain is 4  
 001 = Gain is 2  
 000 = Gain is 1

## B.6.4 STATUS AND COMMUNICATION REGISTER

This register contains all settings related to the communication, including data ready settings and status, and Read mode settings.

### B.6.4.1 Data Ready ( $\overline{DR}$ ) Latency Control – DR\_LTY

This bit determines if the first data ready pulses correspond to settled data, or unsettled data, from each SINC<sup>3</sup> filter. Unsettled data will provide  $\overline{DR}$  pulses every DRCLK period. If this bit is set, unsettled data will wait for 3 DRCLK periods before giving  $\overline{DR}$  pulses and will then give  $\overline{DR}$  pulses every DRCLK period.

### B.6.4.2 Data Ready ( $\overline{DR}$ ) Pin High-Z – DR\_HIZN

This bit defines the non-active state of the Data Ready pin (logic '1' or high-impedance). Using this bit, the user can connect multiple chips with the same  $\overline{DR}$  pin with a pull-up resistor (DR\_HIZN = 0) or a single chip with no external component (DR\_HIZN = 1).

### B.6.4.3 Data Ready Mode – DRMODE<1:0>

If one of the channels is in Reset or shutdown, only one of the data ready pulses is present and the situation is similar to DRMODE = 01 or 10. In the '01', '10' and '11' modes, the ADC channel data to be read is latched at the beginning of a reading, in order to prevent the case of erroneous data when a  $\overline{DR}$  pulse happens during a read. In these modes the two channels are independent.

When these bits are equal to '11', '10' or '01', they control which ADC's data ready is present on the  $\overline{DR}$  pin. When DRMODE = 00, the Data Ready pin output is synchronized with the lagging ADC channel (defined by the PHASE register) and the ADCs are linked together. In this mode, the output of the two ADCs are latched synchronously at the moment of the  $\overline{DR}$  event. This prevents having bad synchronization between the two ADCs. The output is also latched at the beginning of a reading in order not to be updated during a read and not to give erroneous data.

This mode is very useful for power metering applications because the data from both ADCs can be retrieved using this single data ready event which is processed synchronously, even in case of a large phase difference. This mode works as if there was one ADC channel and its data would be 48 bits long, and contain both channel data. As a consequence, if one channel is in Reset or shutdown when DRMODE = 00, no data ready pulse will be present at the outputs (if both channels are not ready in this mode, the data is not considered as ready).

See [Section B.5.9 "Data Ready Pin \(DR\)"](#) for more details about Data Ready pin behavior.

### B.6.4.4 DR Status Flag – DRSTATUS<1:0>

These bits indicate the  $\overline{DR}$  status of both channels, respectively. These flags are set to logic high after each read of the STATUS/COM register. These bits are cleared when a  $\overline{DR}$  event has happened on its respective ADC channel. Writing these bits has no effect.

**Note:** These bits are useful if multiple devices share the same  $\overline{DR}$  output pin (DR\_HIZN = 0) in order to understand from which device the  $\overline{DR}$  event has happened. This configuration can be used for three-phase power metering systems where all three phases share the same Data Ready pin. In case the DRMODE = 00 (linked ADCs), these data ready Status bits will be updated synchronously upon the same event (lagging ADC is ready). These bits are also useful in systems where the  $\overline{DR}$  pin is not used to save MCU I/O.

# PIC18F87J72

## REGISTER B-4: STATUS AND COMMUNICATION REGISTER (ADDRESS 0x09)

R/W-1	R/W-0	R/W-1	R/W-0	R/W-0	R/W-0	R-1	R-1
READ<1>	READ<0>	DR_LTY	DR_HIZN	DRMODE<1>	DRMODE<0>	DRSTATUS<1>	DRSTATUS<0>
bit 7						bit 0	

### Legend:

R = Readable bit	W = Writable bit	U = Unimplemented bit, read as '0'
-n = Value at POR	'1' = Bit is set	'0' = Bit is cleared
		x = Bit is unknown

- bit 7-6      **READ:** Address Loop Setting bits  
 11= Address counter loops on entire register map  
 10= Address counter loops on register TYPES (default)  
 01= Address counter loops on register GROUPS  
 00= Address not incremented, continually read same single register
- bit 5      **DR\_LTY:** Data Ready Latency Control bit  
 1 = "No Latency" conversion,  $\overline{DR}$  pulses after 3 DRCLK periods (default)  
 0 = Unsettled data is available after every DRCLK period
- bit 4      **DR\_HIZn:** Data Ready Pin Inactive State Control bit  
 1 = The Data Ready pin default state is a logic high when data is NOT ready  
 0 = The Data Ready pin default state is high impedance when data is NOT ready (default)
- bit 3-2      **DRMODE<1:0>:** Data Ready Pin (DR) Control bits  
 11= Both data ready pulses from ADC0 and ADC Channel 1 are output on the  $\overline{DR}$  pin  
 10= Data ready pulses from ADC Channel 1 are output on the  $\overline{DR}$  pin;  $\overline{DR}$  from ADC Channel 0 are not present on the pin  
 01= Data ready pulses from ADC Channel 0 are output on the  $\overline{DR}$  pin;  $\overline{DR}$  from ADC Channel 1 are not present on the pin  
 00= Data ready pulses from the lagging ADC between the two are output on the  $\overline{DR}$  pin; the lagging ADC selection depends on the PHASE register and on the OSR (default)
- bit 1-0      **DRSTATUS<1:0>:** Data Ready Status bits  
 11= ADC Channel 1 and Channel 0 data not ready (default)  
 10= ADC Channel 1 data not ready, ADC Channel 0 data ready  
 01= ADC Channel 0 data not ready, ADC Channel 1 data ready  
 00= ADC Channel 1 and Channel 0 data ready



## B.6.5 CONFIGURATION REGISTERS

The Configuration registers contain settings for the internal clock prescaler, the oversampling ratio, the Channel 0 and Channel 1 width settings, the state of the channel Resets and shutdowns, the dithering algorithm control (for Idle tones suppression), and the control bits for the external VREF and external CLK.

### REGISTER B-5: CONFIG1: CONFIGURATION REGISTER 1: (ADDRESS 0x0A)

R/W-0	R/W-0	R/W-0	R/W-1	R/W-0	R/W-0	r-0	r-0
PRESCALE <1>	PRESCALE <0>	OSR<1>	OSR<0>	WIDTH<1>	WIDTH<0>	r	r
bit 7						bit 0	

<b>Legend:</b>	r = Reserved bit
R = Readable bit	W = Writable bit
-n = Value at POR	'1' = Bit is set
	U = Unimplemented bit, read as '0'
	'0' = Bit is cleared
	x = Bit is unknown

- bit 7-6     **PRESCALE<1:0>**: Internal Master Clock (AMCLK) Prescaler Value bits  
           11 = AMCLK = MCLK/8  
           10 = AMCLK = MCLK/4  
           01 = AMCLK = MCLK/2  
           00 = AMCLK = MCLK (default)
- bit 5-4     **OSR<1:0>**: Oversampling Ratio for Delta-Sigma A/D Conversion bits (all channels, DMCLK/DRCLK)  
           11 = 256  
           10 = 128  
           01 = 64 (default)  
           00 = 32
- bit 3-2     **WIDTH<1:0>**: ADC Channel Output Data Word Width bits  
           11 =24-bit mode on both channels  
           10 =24-bit mode on Channel 1, 16-bit mode on Channel 0  
           01 =16-bit mode on Channel 1, 24-bit mode on Channel 0  
           00 =16 bit mode on both channels (default)
- bit 1-0     **Reserved:** Maintain as '0'

# PIC18F87J72

## REGISTER B-6: CONFIG2: CONFIGURATION REGISTER 2 (ADDRESS 0x0B)

R/W-0	R/W-0	R/W-0	R/W-0	R/W-1	R/W-1	R/W-0	r-0
RESET_CH1	RESET_CH0	SHUTDOWN <1>	SHUTDOWN <0>	DITHER<1>	DITHER<0>	VREFEXT	r
bit 7							bit 0

<b>Legend:</b>	r = Reserved bit
R = Readable bit	W = Writable bit
-n = Value at POR	'1' = Bit is set
	U = Unimplemented bit, read as '0'
	'0' = Bit is cleared
	x = Bit is unknown

- bit 7-6      **RESET<1:0>**: Reset Mode Setting for ADCs bits  
 11 = Both CH0 and CH1 ADC are in Reset mode  
 10 = CH1 ADC in Reset mode  
 01 = CH0 ADC in Reset mode  
 00 = Neither Channel in Reset mode (default)
- bit 5-4      **SHUTDOWN<1:0>**: Shutdown Mode Setting for ADCs bits  
 11 = Both CH0 and CH1 ADC are in Shutdown  
 10 = CH1 ADC is in Shutdown  
 01 = CH0 ADC is in Shutdown  
 00 = Neither Channel in Shutdown (default)
- bit 3-2      **DITHER<1:0>**: Control for Dithering Circuit bits  
 11 = Both CH0 and CH1 ADC have dithering circuit applied (default)  
 10 = Only CH1 ADC has dithering circuit applied  
 01 = Only CH0 ADC has dithering circuit applied  
 00 = Neither channel has dithering circuit applied
- bit 1      **VREFEXT**: Internal Voltage Reference Shutdown Control bit  
 1 = Internal Voltage reference disabled; an external voltage reference must be placed between REFIN+/OUT and REFIN-  
 0 = Internal voltage reference enabled (default)
- bit 0      **Reserved**: Resets as '0'; program as '1' after any Reset event

## THE MICROCHIP WEBSITE

Microchip provides online support via our website site at [www.microchip.com](http://www.microchip.com). This website is used as a means to make files and information easily available to customers. Accessible by using your favorite Internet browser, the website contains the following information:

- **Product Support** – Data sheets and errata, application notes and sample programs, design resources, user's guides and hardware support documents, latest software releases and archived software
- **General Technical Support** – Frequently Asked Questions (FAQ), technical support requests, online discussion groups, Microchip consultant program member listing
- **Business of Microchip** – Product selector and ordering guides, latest Microchip press releases, listing of seminars and events, listings of Microchip sales offices, distributors and factory representatives

## CUSTOMER CHANGE NOTIFICATION SERVICE

Microchip's customer notification service helps keep customers current on Microchip products. Subscribers will receive e-mail notification whenever there are changes, updates, revisions or errata related to a specified product family or development tool of interest.

To register, access the Microchip website at [www.microchip.com](http://www.microchip.com). Under "Support", click on "Customer Change Notification" and follow the registration instructions.

## CUSTOMER SUPPORT

Users of Microchip products can receive assistance through several channels:

- Distributor or Representative
- Local Sales Office
- Field Application Engineer (FAE)
- Technical Support

Customers should contact their distributor, representative or Field Application Engineer (FAE) for support. Local sales offices are also available to help customers. A listing of sales offices and locations is included in the back of this document.

**Technical support is available through the website at: <http://microchip.com/support>**

# PIC18F87J72

## PRODUCT IDENTIFICATION SYSTEM

To order or obtain information, e.g., on pricing or delivery, refer to the factory or the listed sales office.

<u>PART NO.</u>	<u>X</u>	<u>/XX</u>	<u>XXX</u>
Device	Temperature Range	Package	Pattern
Device <sup>(1,2)</sup>	PIC18F86J72, PIC18F86J72T PIC18F87J72, PIC18F87J72T		
Temperature Range	I = -40°C to +85°C (Industrial)		
Package	PT = TQFP (Thin Quad Flatpack)		
Pattern	QTP, SQTP, Code or Special Requirements (blank otherwise)		

**Examples:**

- a) PIC18F87J72-I/PT 301 = Industrial temperature, TQFP package, QTP pattern #301.
- b) PIC18F87J72T-I/PT = Tape and reel, Industrial temperature, TQFP package.

**Note 1:** F = Standard Voltage Range  
**Note 2:** T = In tape and reel

NOTES:

---

---

**Note the following details of the code protection feature on Microchip devices:**

- Microchip products meet the specification contained in their particular Microchip Data Sheet.
- Microchip believes that its family of products is one of the most secure families of its kind on the market today, when used in the intended manner and under normal conditions.
- There are dishonest and possibly illegal methods used to breach the code protection feature. All of these methods, to our knowledge, require using the Microchip products in a manner outside the operating specifications contained in Microchip's Data Sheets. Most likely, the person doing so is engaged in theft of intellectual property.
- Microchip is willing to work with the customer who is concerned about the integrity of their code.
- Neither Microchip nor any other semiconductor manufacturer can guarantee the security of their code. Code protection does not mean that we are guaranteeing the product as "unbreakable."

Code protection is constantly evolving. We at Microchip are committed to continuously improving the code protection features of our products. Attempts to break Microchip's code protection feature may be a violation of the Digital Millennium Copyright Act. If such acts allow unauthorized access to your software or other copyrighted work, you may have a right to sue for relief under that Act.

Information contained in this publication regarding device applications and the like is provided only for your convenience and may be superseded by updates. It is your responsibility to ensure that your application meets with your specifications. MICROCHIP MAKES NO REPRESENTATIONS OR WARRANTIES OF ANY KIND WHETHER EXPRESS OR IMPLIED, WRITTEN OR ORAL, STATUTORY OR OTHERWISE, RELATED TO THE INFORMATION, INCLUDING BUT NOT LIMITED TO ITS CONDITION, QUALITY, PERFORMANCE, MERCHANTABILITY OR FITNESS FOR PURPOSE. Microchip disclaims all liability arising from this information and its use. Use of Microchip devices in life support and/or safety applications is entirely at the buyer's risk, and the buyer agrees to defend, indemnify and hold harmless Microchip from any and all damages, claims, suits, or expenses resulting from such use. No licenses are conveyed, implicitly or otherwise, under any Microchip intellectual property rights unless otherwise stated.

*Microchip received ISO/TS-16949:2009 certification for its worldwide headquarters, design and wafer fabrication facilities in Chandler and Tempe, Arizona; Gresham, Oregon and design centers in California and India. The Company's quality system processes and procedures are for its PIC<sup>®</sup> MCUs and dsPIC<sup>®</sup> DSCs, KEELOQ<sup>®</sup> code hopping devices, Serial EEPROMs, microperipherals, nonvolatile memory and analog products. In addition, Microchip's quality system for the design and manufacture of development systems is ISO 9001:2000 certified.*

**QUALITY MANAGEMENT SYSTEM**  
**CERTIFIED BY DNV**  
**== ISO/TS 16949 ==**

### **Trademarks**

The Microchip name and logo, the Microchip logo, AnyRate, dsPIC, FlashFlex, flexPWR, Heldo, JukeBlox, KeeLoq, KeeLoq logo, Klear, LANCheck, LINK MD, MediaLB, MOST, MOST logo, MPLAB, OptoLyzer, PIC, PICSTART, PIC32 logo, RightTouch, SpyNIC, SST, SST Logo, SuperFlash and UNI/O are registered trademarks of Microchip Technology Incorporated in the U.S.A. and other countries.

ClockWorks, The Embedded Control Solutions Company, ETHERSYNCH, Hyper Speed Control, HyperLight Load, IntelliMOS, mTouch, Precision Edge, and QUIET-WIRE are registered trademarks of Microchip Technology Incorporated in the U.S.A.

Analog-for-the-Digital Age, Any Capacitor, AnyIn, AnyOut, BodyCom, chipKIT, chipKIT logo, CodeGuard, dsPICDEM, dsPICDEM.net, Dynamic Average Matching, DAM, ECAN, EtherGREEN, In-Circuit Serial Programming, ICSP, Inter-Chip Connectivity, JitterBlocker, KlearNet, KlearNet logo, MiWi, motorBench, MPASM, MPF, MPLAB Certified logo, MPLIB, MPLINK, MultiTRAK, NetDetach, Omniscient Code Generation, PICDEM, PICDEM.net, PICkit, PICtail, PureSilicon, RightTouch logo, REAL ICE, Ripple Blocker, Serial Quad I/O, SQL, SuperSwitcher, SuperSwitcher II, Total Endurance, TSHARC, USBCheck, VariSense, ViewSpan, WiperLock, Wireless DNA, and ZENA are trademarks of Microchip Technology Incorporated in the U.S.A. and other countries.

SQTP is a service mark of Microchip Technology Incorporated in the U.S.A.

Silicon Storage Technology is a registered trademark of Microchip Technology Inc. in other countries.

GestIC is a registered trademark of Microchip Technology Germany II GmbH & Co. KG, a subsidiary of Microchip Technology Inc., in other countries.

All other trademarks mentioned herein are property of their respective companies.

© 2010-2016, Microchip Technology Incorporated, Printed in the U.S.A., All Rights Reserved.

ISBN: 978-1-5224-0933-5



# MICROCHIP

## Worldwide Sales and Service

### AMERICAS

#### Corporate Office

2355 West Chandler Blvd.  
Chandler, AZ 85224-6199

Tel: 480-792-7200

Fax: 480-792-7277

Technical Support:

[http://www.microchip.com/  
support](http://www.microchip.com/support)

Web Address:

[www.microchip.com](http://www.microchip.com)

#### Atlanta

Duluth, GA

Tel: 678-957-9614

Fax: 678-957-1455

#### Austin, TX

Tel: 512-257-3370

#### Boston

Westborough, MA

Tel: 774-760-0087

Fax: 774-760-0088

#### Chicago

Itasca, IL

Tel: 630-285-0071

Fax: 630-285-0075

#### Cleveland

Independence, OH

Tel: 216-447-0464

Fax: 216-447-0643

#### Dallas

Addison, TX

Tel: 972-818-7423

Fax: 972-818-2924

#### Detroit

Novi, MI

Tel: 248-848-4000

#### Houston, TX

Tel: 281-894-5983

#### Indianapolis

Noblesville, IN

Tel: 317-773-8323

Fax: 317-773-5453

#### Los Angeles

Mission Viejo, CA

Tel: 949-462-9523

Fax: 949-462-9608

#### New York, NY

Tel: 631-435-6000

#### San Jose, CA

Tel: 408-735-9110

#### Canada - Toronto

Tel: 905-695-1980

Fax: 905-695-2078

### ASIA/PACIFIC

#### Asia Pacific Office

Suites 3707-14, 37th Floor  
Tower 6, The Gateway  
Harbour City, Kowloon

#### Hong Kong

Tel: 852-2943-5100

Fax: 852-2401-3431

#### Australia - Sydney

Tel: 61-2-9868-6733

Fax: 61-2-9868-6755

#### China - Beijing

Tel: 86-10-8569-7000

Fax: 86-10-8528-2104

#### China - Chengdu

Tel: 86-28-8665-5511

Fax: 86-28-8665-7889

#### China - Chongqing

Tel: 86-23-8980-9588

Fax: 86-23-8980-9500

#### China - Dongguan

Tel: 86-769-8702-9880

#### China - Guangzhou

Tel: 86-20-8755-8029

#### China - Hangzhou

Tel: 86-571-8792-8115

Fax: 86-571-8792-8116

#### China - Hong Kong SAR

Tel: 852-2943-5100

Fax: 852-2401-3431

#### China - Nanjing

Tel: 86-25-8473-2460

Fax: 86-25-8473-2470

#### China - Qingdao

Tel: 86-532-8502-7355

Fax: 86-532-8502-7205

#### China - Shanghai

Tel: 86-21-5407-5533

Fax: 86-21-5407-5066

#### China - Shenyang

Tel: 86-24-2334-2829

Fax: 86-24-2334-2393

#### China - Shenzhen

Tel: 86-755-8864-2200

Fax: 86-755-8203-1760

#### China - Wuhan

Tel: 86-27-5980-5300

Fax: 86-27-5980-5118

#### China - Xian

Tel: 86-29-8833-7252

Fax: 86-29-8833-7256

### ASIA/PACIFIC

#### China - Xiamen

Tel: 86-592-2388138

Fax: 86-592-2388130

#### China - Zhuhai

Tel: 86-756-3210040

Fax: 86-756-3210049

#### India - Bangalore

Tel: 91-80-3090-4444

Fax: 91-80-3090-4123

#### India - New Delhi

Tel: 91-11-4160-8631

Fax: 91-11-4160-8632

#### India - Pune

Tel: 91-20-3019-1500

#### Japan - Osaka

Tel: 81-6-6152-7160

Fax: 81-6-6152-9310

#### Japan - Tokyo

Tel: 81-3-6880-3770

Fax: 81-3-6880-3771

#### Korea - Daegu

Tel: 82-53-744-4301

Fax: 82-53-744-4302

#### Korea - Seoul

Tel: 82-2-554-7200

Fax: 82-2-558-5932 or

82-2-558-5934

#### Malaysia - Kuala Lumpur

Tel: 60-3-6201-9857

Fax: 60-3-6201-9859

#### Malaysia - Penang

Tel: 60-4-227-8870

Fax: 60-4-227-4068

#### Philippines - Manila

Tel: 63-2-634-9065

Fax: 63-2-634-9069

#### Singapore

Tel: 65-6334-8870

Fax: 65-6334-8850

#### Taiwan - Hsin Chu

Tel: 886-3-5778-366

Fax: 886-3-5770-955

#### Taiwan - Kaohsiung

Tel: 886-7-213-7828

#### Taiwan - Taipei

Tel: 886-2-2508-8600

Fax: 886-2-2508-0102

#### Thailand - Bangkok

Tel: 66-2-694-1351

Fax: 66-2-694-1350

### EUROPE

#### Austria - Wels

Tel: 43-7242-2244-39

Fax: 43-7242-2244-393

#### Denmark - Copenhagen

Tel: 45-4450-2828

Fax: 45-4485-2829

#### France - Paris

Tel: 33-1-69-53-63-20

Fax: 33-1-69-30-90-79

#### Germany - Dusseldorf

Tel: 49-2129-3766400

#### Germany - Karlsruhe

Tel: 49-721-625370

#### Germany - Munich

Tel: 49-89-627-144-0

Fax: 49-89-627-144-44

#### Italy - Milan

Tel: 39-0331-742611

Fax: 39-0331-466781

#### Italy - Venice

Tel: 39-049-7625286

#### Netherlands - Drunen

Tel: 31-416-690399

Fax: 31-416-690340

#### Poland - Warsaw

Tel: 48-22-3325737

#### Spain - Madrid

Tel: 34-91-708-08-90

Fax: 34-91-708-08-91

#### Sweden - Stockholm

Tel: 46-8-5090-4654

#### UK - Wokingham

Tel: 44-118-921-5800

Fax: 44-118-921-5820

06/23/16

## X-ON Electronics

Largest Supplier of Electrical and Electronic Components

*Click to view similar products for [8-bit Microcontrollers - MCU category](#):*

*Click to view products by [Microchip manufacturer](#):*

Other Similar products are found below :

[CY8C20524-12PVXIT](#) [MB95F013KPMC-G-SNE2](#) [MB95F263KPF-G-SNE2](#) [MB95F264KPFT-G-SNE2](#) [MB95F398KPMC-G-SNE2](#)  
[MB95F478KPMC2-G-SNE2](#) [MB95F564KPF-G-SNE2](#) [MB95F636KWQN-G-SNE1](#) [MB95F696KPMC-G-SNE2](#) [MB95F698KPMC2-G-SNE2](#)  
[MB95F698KPMC-G-SNE2](#) [MB95F818KPMC1-G-SNE2](#) [901015X](#) [CY8C3MFIDOCK-125](#) [403708R](#) [MB95F354EPF-G-SNE2](#)  
[MB95F564KWQN-G-SNE1](#) [MB95F636KP-G-SH-SNE2](#) [MB95F694KPMC-G-SNE2](#) [MB95F778JPMC1-G-SNE2](#) [MB95F818KPMC-G-SNE2](#)  
[LC87F0G08AUJA-AH](#) [CP8361BT](#) [CG8421AF](#) [MB95F202KPF-G-SNE2](#) [DF36014FPV](#) [5962-8768407MUA](#) [MB95F318EPMC-G-SNE2](#)  
[MB94F601APMC1-GSE1](#) [MB95F656EPF-G-SNE2](#) [LC78615E-01US-H](#) [LC87F5WC8AVU-QIP-H](#) [MB95F108AJSPMC-G-JNE1](#) [73S1210F-](#)  
[68M/F/PJ](#) [MB89F538-101PMC-GE1](#) [LC87F7DC8AVU-QIP-H](#) [MB95F876KPMC-G-SNE2](#) [MB88386PMC-GS-BNDE1](#) [LC87FBK08AU-](#)  
[SSOP-H](#) [LC87F2C64AU-QFP-H](#) [MB95F636KNWQN-G-118-SNE1](#) [MB95F136NBSTPFV-GS-N2E1](#) [LC87F5NC8AVU-QIP-E](#)  
[LC87F76C8AU-TQFP-E](#) [LC87F2G08AU-SSOP-E](#) [CP8085AT](#) [MB95F564KPF-G-UNE2](#) [MC9S08PA4VWJ](#) [MC9S08QG8CDTE](#)  
[MC9S08SH4CWJR](#)