



PIC24FJ256GA705 FAMILY

16-Bit General Purpose Microcontrollers with 256-Kbyte Flash and 16-Kbyte RAM in Low Pin Count Packages

High-Performance CPU

- Modified Harvard Architecture
- Up to 16 MIPS Operation @ 32 MHz
- 8 MHz Fast RC Internal Oscillator:
 - 96 MHz PLL option
 - Multiple clock divide options
 - Fast start-up
- 17-Bit x 17-Bit Single-Cycle Hardware Fractional/Integer Multiplier
- 32-Bit by 16-Bit Hardware Divider
- 16-Bit x 16-Bit Working Register Array
- C Compiler Optimized Instruction Set Architecture
- Two Address Generation Units for Separate Read and Write Addressing of Data Memory
- Six-Channel DMA Controller

Analog Features

- Up to 14-Channel, Software-Selectable, 10/12-Bit Analog-to-Digital Converter:
 - 12-bit, 200K samples/second conversion rate (single Sample-and-Hold)
 - Sleep mode operation
 - Charge pump for operating at lower AVDD
 - Band gap reference input feature
 - Windowed threshold compare feature
 - Auto-scan feature
- Three Analog Comparators with Input Multiplexing:
 - Programmable reference voltage for comparators
- LVD Interrupt Above/Below Programmable VLVD Level
- Charge Time Measurement Unit (CTMU):
 - Allows measurement of capacitance and time
 - Operational in Sleep

Low-Power Features

- Sleep and Idle modes Selectively Shut Down Peripherals and/or Core for Substantial Power Reduction and Fast Wake-up
- Doze mode allows CPU to Run at a Lower Clock Speed than Peripherals
- Alternate Clock modes allow On-the-Fly Switching to a Lower Clock Speed for Selective Power Reduction

Special Microcontroller Features

- Supply Voltage Range of 2.0V to 3.6V
- Dual Voltage Regulators:
 - 1.8V core regulator
 - 1.2V regulator for Retention Sleep mode
- Operating Ambient Temperature Range of -40°C to +125°C
- ECC Flash Memory (256 Kbytes):
 - Single Error Correction (SEC)
 - Double Error Detection (DED)
 - 10,000 erase/write cycle endurance, typical
 - Data retention: 20 years minimum
 - Self-programmable under software control
- 16-Kbyte SRAM
- Programmable Reference Clock Output
- In-Circuit Serial Programming™ (ICSP™) and In-Circuit Emulation (ICE) via 2 Pins
- JTAG Boundary Scan Support
- Fail-Safe Clock Monitor Operation:
 - Detects clock failure and switches to on-chip, Low-Power RC (LPRC) Oscillator
- Power-on Reset (POR), Brown-out Reset (BOR) and Oscillator Start-up Timer (OST)
- Programmable Low-Voltage Detect (LVD)
- Flexible Watchdog Timer (WDT) with its Own RC Oscillator for Reliable Operation

Qualification and Class B Support

- AEC-Q100 REVG (Grade 1 -40°C to +125°C)
- Class B Safety Library, IEC 60730

PIC24FJ256GA705 FAMILY

Peripheral Features

- High-Current Sink/Source 18 mA/18 mA on All I/O Pins
- Independent, Low-Power 32 kHz Timer Oscillator
- Timer1: 16-Bit Timer/Counter with External Crystal Oscillator; Timer1 can Provide an A/D Trigger
- Timer2,3: 16-Bit Timer/Counter, can Create 32-Bit Timer; Timer3 can Provide an A/D Trigger
- Three Input Capture modules, Each with a 16-Bit Timer
- Three Output Compare/PWM modules, Each with a 16-Bit Timer
- Four MCCP modules, Each with a Dedicated 16/32-Bit Timer:
 - One 6-output MCCP module
 - Three 2-output MCCP modules
- Three Variable Widths, Synchronous Peripheral Interface (SPI) Ports on All Devices; Three Operation modes:
 - Three-wire SPI (supports all four SPI modes)
 - 8 by 16-bit or 8 by 8-bit FIFO
 - I²S mode
- Two I²C Masters and Slaves w/Address Masking, and IPMI Support
- Two UART modules:
 - LIN/J2602 bus support (auto-wake-up, Auto-Baud Detect (ABD), Break character support)
 - RS-232 and RS-485 support
 - IrDA[®] mode (hardware encoder/decoder functions)
- Five External Interrupt Pins
- Parallel Master Port/Enhanced Parallel Slave Port (PMP/EPSP), 8-Bit Data with External Programmable Control (polarity and protocol)
- Enhanced CRC module
- Reference Clock Output with Programmable Divider
- Two Configurable Logic Cell (CLC) Blocks:
 - Two inputs and one output, all mappable to peripherals or I/O pins
 - AND/OR/XOR logic and D/JK flip-flop functions
- Peripheral Pin Select (PPS) with Independent I/O Mapping of Many Peripherals

TABLE 1: PIC24FJ256GA705 FAMILY DEVICES

Device	Memory		Pins	GPIO	DMA Channels	Peripherals													JTAG
	Program (bytes)	SRAM (bytes)				10/12-Bit A/D Channels	Comparators	CRC	MCCP 6-Output/2-Output	IC/OC/PWM	16-Bit Timers	I ² C	Variable Width SPI	LIN-USART/IrDA [®]	CTMU Channels	EPMP (Address/Data Line)	CLC	RTCC	
PIC24FJ64GA705	64K	16K	48	40	6	14	3	Yes	1/3	3/3	3	2	3	2	13	10/8	2	Yes	Yes
PIC24FJ128GA705	128K	16K	48	40	6	14	3	Yes	1/3	3/3	3	2	3	2	13	10/8	2	Yes	Yes
PIC24FJ256GA705	256K	16K	48	40	6	14	3	Yes	1/3	3/3	3	2	3	2	13	10/8	2	Yes	Yes
PIC24FJ64GA704	64K	16K	44	36	6	14	3	Yes	1/3	3/3	3	2	3	2	13	10/8	2	Yes	Yes
PIC24FJ128GA704	128K	16K	44	36	6	14	3	Yes	1/3	3/3	3	2	3	2	13	10/8	2	Yes	Yes
PIC24FJ256GA704	256K	16K	44	36	6	14	3	Yes	1/3	3/3	3	2	3	2	13	10/8	2	Yes	Yes
PIC24FJ64GA702	64K	16K	28	22	6	10	3	Yes	1/3	3/3	3	2	3	2	12	No	2	Yes	Yes
PIC24FJ128GA702	128K	16K	28	22	6	10	3	Yes	1/3	3/3	3	2	3	2	12	No	2	Yes	Yes
PIC24FJ256GA702	256K	16K	28	22	6	10	3	Yes	1/3	3/3	3	2	3	2	12	No	2	Yes	Yes

PIC24FJ256GA705 FAMILY

Pin Diagrams (PIC24FJ256GA702 Devices)

28-Pin QFN, UQFN^(1,2)

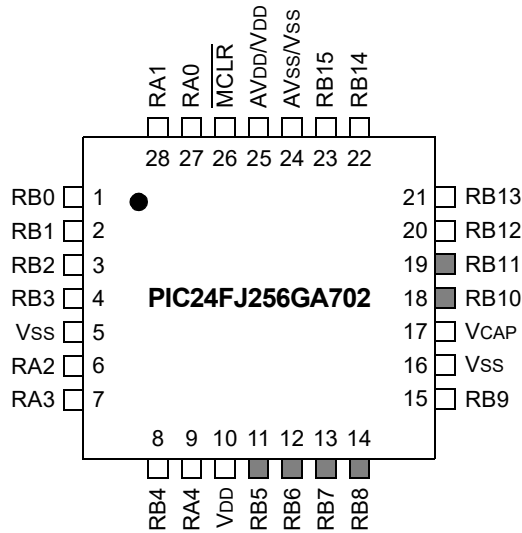

Legend: See Table 2 for a complete description of pin functions.

Note 1: Gray shading indicates 5.5V tolerant input pins.

Note 2: The large center pad on the bottom of the package may be left floating or connected to Vss.

TABLE 2: COMPLETE PIN FUNCTION DESCRIPTIONS (PIC24FJ256GA702 QFN, UQFN)

Pin	Function	Pin	Function
1	PGD1/AN2/CTCMP/C2INB/ RP0 /RB0	15	TDO/C1INC/C2INC/C3INC/TMPRN/ RP9 /SDA1/T1CK/CTED4/RB9
2	PGC1/AN1-/AN3/C2INA/ RP1 /CTED12/RB1	16	Vss
3	AN4/C1INB/ RP2 /SDA2/CTED13/RB2	17	VCAP
4	AN5/C1INA/ RP3 /SCL2/CTED8/RB3	18	PGD2/TDI/ RP10 /OCM1C/CTED11/RB10
5	Vss	19	PGC2/TMS/REF1/ RP11 /CTED9/RB11
6	OSCI/CLKI/C1IND/RA2	20	AN8/LVDIN/ RP12 /RB12
7	OSCO/CLKO/C2IND/RA3	21	AN7/C1INC/ RP13 /OCM1D/CTPLS/RB13
8	SOSCI/ RP4 /RB4	22	CVREF/AN6/C3INB/ RP14 /CTED5/RB14
9	SOSCO/PWRLCLK/RA4	23	AN9/C3INA/ RP15 /CTED6/RB15
10	VDD	24	AVss/Vss
11	PGD3/ RP5 /ASDA1/OCM1E/RB5	25	AVDD/VDD
12	PGC3/ RP6 /ASCL1/OCM1F/RB6	26	MCLR
13	RP7 /OCM1A/CTED3/INT0/RB7	27	VREF+/CVREF+/AN0/C3INC/ RP26 /CTED1/RA0
14	TCK/ RP8 /SCL1/OCM1B/CTED10/RB8	28	VREF-/CVREF-/AN1/C3IND/ RP27 /CTED2/RA1

Legend: **RPn** represents remappable pins for Peripheral Pin Select (PPS) functions.

PIC24FJ256GA705 FAMILY

Pin Diagrams (PIC24FJ256GA702 Devices)

28-Pin SOIC, SSOP, SPDIP

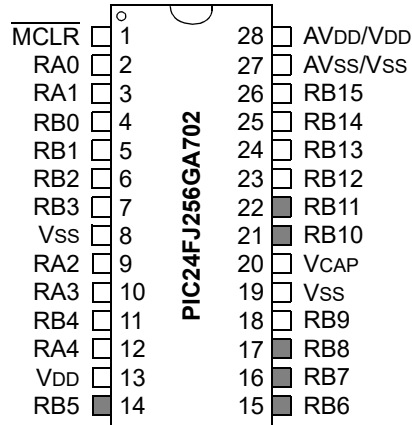

Legend: See Table 3 for a complete description of pin functions.

Note: Gray shading indicates 5.5V tolerant input pins.

TABLE 3: COMPLETE PIN FUNCTION DESCRIPTIONS (PIC24FJ256GA702 SOIC, SSOP, SPDIP)

Pin	Function	Pin	Function
1	MCLR	15	PGC3/ RP6 /ASCL1/OCM1F/RB6
2	VREF+/CVREF+/AN0/C3INC/ RP26 /CTED1/RA0	16	RP7 /OCM1A/CTED3/INT0/RB7
3	VREF-/CVREF-/AN1/C3IND/ RP27 /CTED2/RA1	17	TCK/ RP8 /SCL1/OCM1B/CTED10/RB8
4	PGD1/AN2/CTCMP/C2INB/ RP0 /RB0	18	TDO/C1INC/C2INC/C3INC/ TMPRN / RP9 /SDA1/T1CK/CTED4/RB9
5	PGC1/AN1-/AN3/C2INA/ RP1 /CTED12/RB1	19	Vss
6	AN4/C1INB/ RP2 /SDA2/CTED13/RB2	20	VCAP
7	AN5/C1INA/ RP3 /SCL2/CTED8/RB3	21	PGD2/TDI/ RP10 /OCM1C/CTED11/RB10
8	Vss	22	PGC2/TMS/REF11/ RP11 /CTED9/RB11
9	OSCI/CLKI/C1IND/RA2	23	AN8/LVDIN/ RP12 /RB12
10	OSCO/CLKO/C2IND/RA3	24	AN7/C1INC/ RP13 /OCM1D/CTPLS/RB13
11	SOSCI/ RP4 /RB4	25	CVREF/AN6/C3INB/ RP14 /CTED5/RB14
12	SOSCO/PWRLCLK/RA4	26	AN9/C3INA/ RP15 /CTED6/RB15
13	VDD	27	AVss/Vss
14	PGD3/ RP5 /ASDA1/OCM1E/RB5	28	AVDD/VDD

Legend: **RPn** represents remappable pins for Peripheral Pin Select (PPS) functions.

Pin Diagrams (PIC24FJ256GA704 Devices)

44-Pin TQFP

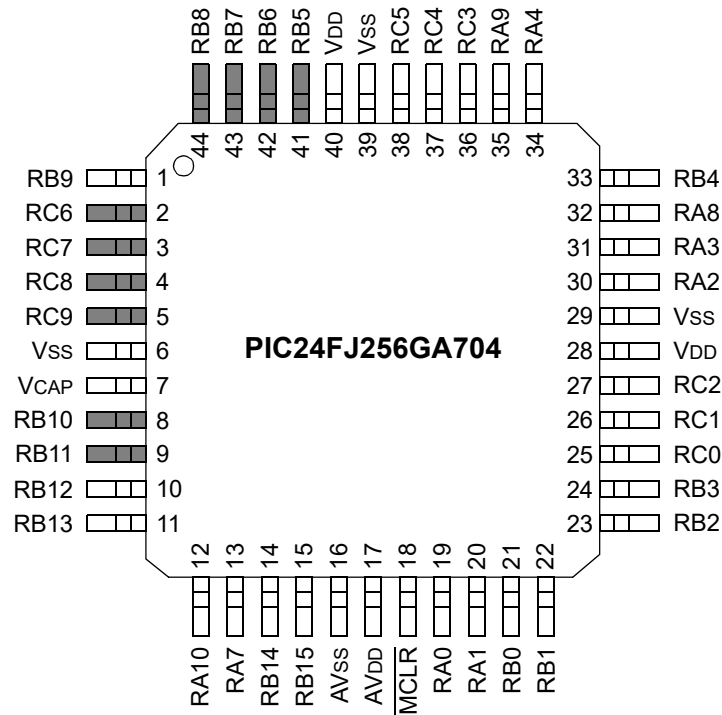

Legend: See [Table 4](#) for a complete description of pin functions.

Note: Gray shading indicates 5.5V tolerant input pins.

PIC24FJ256GA705 FAMILY

TABLE 4: COMPLETE PIN FUNCTION DESCRIPTIONS (PIC24FJ256GA704 TQFP)

Pin	Function	Pin	Function
1	C1INC/C2INC/C3INC/TMPRN/ RP9 /SDA1/T1CK/CTED4/PMD3/RB9	23	AN4/C1INB/ RP2 /SDA2/CTED13/RB2
2	RP22 /PMA1/PMALH/RC6	24	AN5/C1INA/ RP3 /SCL2/CTED8/RB3
3	RP23 /PMA0/PMALL/RC7	25	AN10/ RP16 /PMBE1/RC0
4	RP24 /PMA5/RC8	26	AN11/ RP17 /PMA15/PMCS2/RC1
5	RP25 /CTED7/PMA6/RC9	27	AN12/ RP18 /PMACK1/RC2
6	V _{SS}	28	V _{DD}
7	V _{CAP}	29	V _{SS}
8	PGD2/ RP10 /OCM1C/CTED11/PMD2/RB10	30	OSCI/CLKI/C1IND/RA2
9	PGC2/REFI1/ RP11 /CTED9/PMD1/RB11	31	OSCO/CLKO/C2IND/RA3
10	AN8/LVDIN/ RP12 /PMD0/RB12	32	TDO/PMA8/RA8
11	AN7/C1INC/ RP13 /OCM1D/CTPLS/PMRD/PMWR/RB13	33	SOSCI/ RP4 /RB4
12	TMS/ RP28 /PMA2/PMALU/RA10	34	SOSCO/PWRLCLK/RA4
13	TCK/PMA7/RA7	35	TDI/PMA9/RA9
14	CVREF/AN6/C3INB/ RP14 /CTED5/PMWR/PMENB/RB14	36	AN13/ RP19 /PMBE0/RC3
15	AN9/C3INA/ RP15 /CTED6/PMA14/PMCS/PMCS1/RB15	37	RP20 /PMA4/RC4
16	AV _{SS}	38	RP21 /PMA3/RC5
17	AV _{DD}	39	V _{SS}
18	MCLR	40	V _{DD}
19	VREF+/CVREF+/AN0/C3INC/ RP26 /CTED1/RA0	41	PGD3/ RP5 /ASDA1/OCM1E/PMD7/RB5
20	VREF-/CVREF-/AN1/C3IND/ RP27 /CTED2/RA1	42	PGC3/ RP6 /ASCL1/OCM1F/PMD6/RB6
21	PGD1/AN2/CTCMP/C2INB/ RP0 /RB0	43	RP7 /OCM1A/CTED3/PMD5/INT0/RB7
22	PGC1/AN1-/AN3/C2INA/ RP1 /CTED12/RB1	44	RP8 /SCL1/OCM1B/CTED10/PMD4/RB8

Legend: **RPn** represents remappable pins for Peripheral Pin Select (PPS) functions.

PIC24FJ256GA705 FAMILY

Pin Diagrams (PIC24FJ256GA705 Devices)

48-Pin UQFN

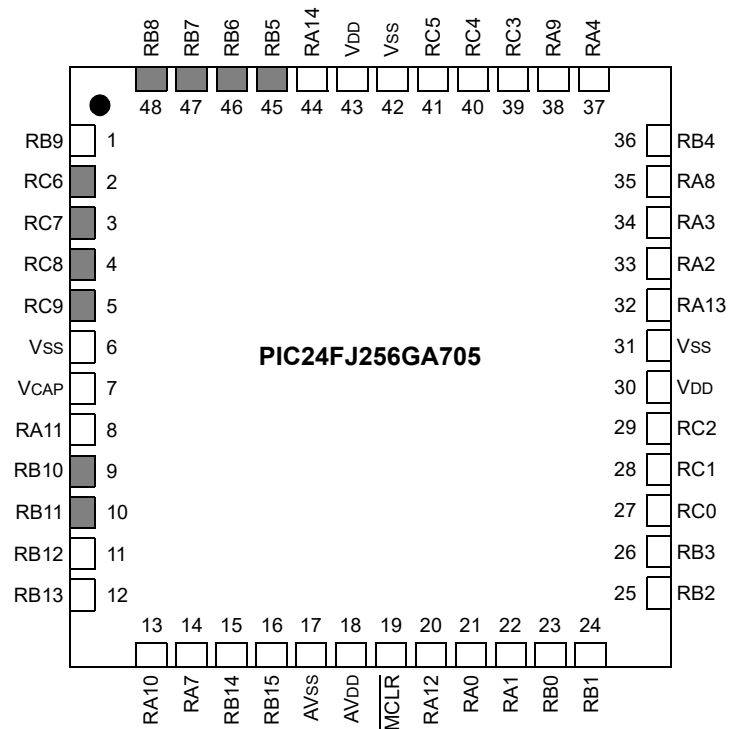

Legend: See [Table 5](#) for a complete description of pin functions.

Note: Gray shading indicates 5.5V tolerant input pins.

PIC24FJ256GA705 FAMILY

TABLE 5: COMPLETE PIN FUNCTION DESCRIPTIONS (PIC24FJ256GA705 UQFN)

Pin	Function	Pin	Function
1	C1INC/C2INC/C3INC/TMPRN/ RP9 /SDA1/T1CK/CTED4/PMD3/RB9	25	AN4/C1INB/ RP2 /SDA2/CTED13/RB2
2	RP22 /PMA1/PMALH/RC6	26	AN5/C1INA/ RP3 /SCL2/CTED8/RB3
3	RP23 /PMA0/PMALL/RC7	27	AN10/ RP16 /PMBE1/RC0
4	RP24 /PMA5/RC8	28	AN11/ RP17 /PMA15/PMCS2/RC1
5	RP25 /CTED7/PMA6/RC9	29	AN12/ RP18 /PMACK1/RC2
6	Vss	30	VDD
7	VCAP	31	Vss
8	RPI29 /RA11	32	RPI31 /RA13
9	PGD2/ RP10 /OCM1C/CTED11/PMD2/RB10	33	OSCI/CLKI/C1IND/RA2
10	PGC2/REFI1/ RP11 /CTED9/PMD1/RB11	34	OSCO/CLKO/C2IND/RA3
11	AN8/LVDIN/ RP12 /PMD0/RB12	35	TDO/PMA8/RA8
12	AN7/C1INC/ RP13 /OCM1D/CTPLS/PMRD/PMWR/RB13	36	SOSCI/ RP4 /RB4
13	TMS/ RP28 /PMA2/PMALU/RA10	37	SOSCO/PWRLCLK/RA4
14	TCK/PMA7/RA7	38	TDI/PMA9/RA9
15	CVREF/AN6/C3INB/ RP14 /CTED5/PMWR/PMENB/RB14	39	AN13/ RP19 /PMBE0/RC3
16	AN9/C3INA/ RP15 /CTED6/PMA14/PMCS/PMCS1/RB15	40	RP20 /PMA4/RC4
17	AVss	41	RP21 /PMA3/RC5
18	AVDD	42	Vss
19	MCLR	43	VDD
20	RPI30 /RA12	44	RPI32 /RA14
21	VREF+/CVREF+/AN0/C3INC/ RP26 /CTED1/RA0	45	PGD3/ RP5 /ASDA1/OCM1E/PMD7/RB5
22	VREF-/CVREF-/AN1/C3IND/ RP27 /CTED2/RA1	46	PGC3/ RP6 /ASCL1/OCM1F/PMD6/RB6
23	PGD1/AN2/CTCMP/C2INB/ RP0 /RB0	47	RP7 /OCM1A/CTED3/PMD5/INT0/RB7
24	PGC1/AN1-JAN3/C2INA/ RP1 /CTED12/RB1	48	RP8 /SCL1/OCM1B/CTED10/PMD4/RB8

Legend: **RPn** and **RPI**n represent remappable pins for Peripheral Pin Select (PPS) functions.

PIC24FJ256GA705 FAMILY

Pin Diagrams (PIC24FJ256GA705 Devices)

48-Pin TQFP

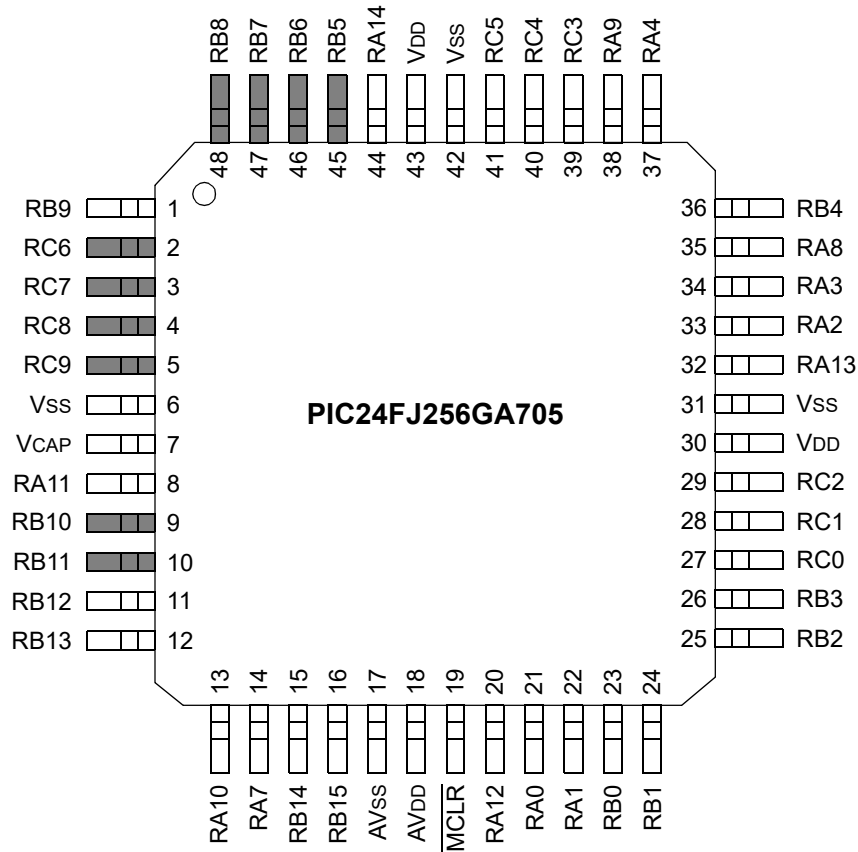

Legend: See [Table 6](#) for a complete description of pin functions.

Note: Gray shading indicates 5.5V tolerant input pins.

PIC24FJ256GA705 FAMILY

TABLE 6: COMPLETE PIN FUNCTION DESCRIPTIONS (PIC24FJ256GA705 TQFP)

Pin	Function	Pin	Function
1	C1INC/C2INC/C3INC/TMPRN/ RP9 /SDA1/T1CK/CTED4/PMD3/RB9	25	AN4/C1INB/ RP2 /SDA2/CTED13/RB2
2	RP22 /PMA1/PMALH/RC6	26	AN5/C1INA/ RP3 /SCL2/CTED8/RB3
3	RP23 /PMA0/PMALL/RC7	27	AN10/ RP16 /PMBE1/RC0
4	RP24 /PMA5/RC8	28	AN11/ RP17 /PMA15/PMCS2/RC1
5	RP25 /CTED7/PMA6/RC9	29	AN12/ RP18 /PMACK1/RC2
6	Vss	30	VDD
7	VCAP	31	Vss
8	RPI29 /RA11	32	RPI31 /RA13
9	PGD2/ RP10 /OCM1C/CTED11/PMD2/RB10	33	OSCI/CLKI/C1IND/RA2
10	PGC2/REFI1/ RP11 /CTED9/PMD1/RB11	34	OSCO/CLKO/C2IND/RA3
11	AN8/LVDIN/ RP12 /PMD0/RB12	35	TDO/PMA8/RA8
12	AN7/C1INC/ RP13 /OCM1D/CTPLS/PMRD/PMWR/RB13	36	SOSCI/ RP4 /RB4
13	TMS/ RP28 /PMA2/PMALU/RA10	37	SOSCO/PWRLCLK/RA4
14	TCK/PMA7/RA7	38	TDI/PMA9/RA9
15	CVREF/AN6/C3INB/ RP14 /CTED5/PMWR/PMENB/RB14	39	AN13/ RP19 /PMBE0/RC3
16	AN9/C3INA/ RP15 /CTED6/PMA14/PMCS/PMCS1/RB15	40	RP20 /PMA4/RC4
17	AVss	41	RP21 /PMA3/RC5
18	AVDD	42	Vss
19	MCLR	43	VDD
20	RPI30 /RA12	44	RPI32 /RA14
21	VREF+/CVREF+/AN0/C3INC/ RP26 /CTED1/RA0	45	PGD3/ RP5 /ASDA1/OCM1E/PMD7/RB5
22	VREF-/CVREF-/AN1/C3IND/ RP27 /CTED2/RA1	46	PGC3/ RP6 /ASCL1/OCM1F/PMD6/RB6
23	PGD1/AN2/CTCMP/C2INB/ RP0 /RB0	47	RP7 /OCM1A/CTED3/PMD5/INT0/RB7
24	PGC1/AN1-AN3/C2INA/ RP1 /CTED12/RB1	48	RP8 /SCL1/OCM1B/CTED10/PMD4/RB8

Legend: **RPn** and **RPin** represent remappable pins for Peripheral Pin Select (PPS) functions.

Table of Contents

1.0	Device Overview	15
2.0	Guidelines for Getting Started with 16-Bit Microcontrollers	29
3.0	CPU	35
4.0	Memory Organization	41
5.0	Direct Memory Access Controller (DMA)	63
6.0	Flash Program Memory	71
7.0	Resets	79
8.0	Interrupt Controller	85
9.0	Oscillator Configuration	97
10.0	Power-Saving Features	113
11.0	I/O Ports	125
12.0	Timer1	159
13.0	Timer2/3	161
14.0	Input Capture with Dedicated Timers	167
15.0	Output Compare with Dedicated Timers	173
16.0	Capture/Compare/PWM/Timer Modules (MCCP)	183
17.0	Serial Peripheral Interface (SPI)	199
18.0	Inter-Integrated Circuit (I ² C)	219
19.0	Universal Asynchronous Receiver Transmitter (UART)	227
20.0	Enhanced Parallel Master Port (EPMP)	237
21.0	Real-Time Clock and Calendar (RTCC) with Timestamp	249
22.0	32-Bit Programmable Cyclic Redundancy Check (CRC) Generator	269
23.0	Configurable Logic Cell (CLC) Generator	275
24.0	12-Bit A/D Converter with Threshold Detect	285
25.0	Triple Comparator Module	307
26.0	Comparator Voltage Reference	313
27.0	Charge Time Measurement Unit (CTMU)	315
28.0	High/Low-Voltage Detect (HLVD)	325
29.0	Special Features	327
30.0	Development Support	343
31.0	Instruction Set Summary	345
32.0	Electrical Characteristics	353
33.0	Packaging Information	387
	Appendix A: Revision History	411
	Index	413
	The Microchip Website	419
	Customer Change Notification Service	419
	Customer Support	419
	Product Identification System	421

PIC24FJ256GA705 FAMILY

TO OUR VALUED CUSTOMERS

It is our intention to provide our valued customers with the best documentation possible to ensure successful use of your Microchip products. To this end, we will continue to improve our publications to better suit your needs. Our publications will be refined and enhanced as new volumes and updates are introduced.

If you have any questions or comments regarding this publication, please contact the Marketing Communications Department via E-mail at docerrors@microchip.com. We welcome your feedback.

Most Current Data Sheet

To obtain the most up-to-date version of this data sheet, please register at our Worldwide Website at:

<http://www.microchip.com>

You can determine the version of a data sheet by examining its literature number found on the bottom outside corner of any page. The last character of the literature number is the version number, (e.g., DS30000000A is version A of document DS30000000).

Errata

An errata sheet, describing minor operational differences from the data sheet and recommended workarounds, may exist for current devices. As device/documentation issues become known to us, we will publish an errata sheet. The errata will specify the revision of silicon and revision of document to which it applies.

To determine if an errata sheet exists for a particular device, please check with one of the following:

- Microchip's Worldwide Website; <http://www.microchip.com>
- Your local Microchip sales office (see last page)

When contacting a sales office, please specify which device, revision of silicon and data sheet (include literature number) you are using.

Customer Notification System

Register on our website at www.microchip.com to receive the most current information on all of our products.

Referenced Sources

This device data sheet is based on the following individual chapters of the “*dsPIC33/PIC24 Family Reference Manual*”. These documents should be considered as the general reference for the operation of a particular module or device feature.

Note 1: To access the documents listed below, browse to the documentation section of the [PIC24FJ256GA705](#) product page of the Microchip website (www.microchip.com) or select a family reference manual section from the following list.

In addition to parameters, features and other documentation, the resulting page provides links to the related family reference manual sections.

- “CPU with Extended Data Space (EDS)” ([DS39732](#))
- “Direct Memory Access Controller (DMA)” ([DS30009742](#))
- “PIC24F Flash Program Memory” ([DS30009715](#))
- “Data Memory with Extended Data Space (EDS)” ([DS39733](#))
- “Reset” ([DS39712](#))
- “Interrupts” ([DS70000600](#))
- “Oscillator” ([DS39700](#))
- “Power-Saving Features with Deep Sleep” ([DS39727](#))
- “I/O Ports with Peripheral Pin Select (PPS)” ([DS30009711](#))
- “Timers” ([DS39704](#))
- “Input Capture with Dedicated Timer” ([DS70000352](#))
- “Output Compare with Dedicated Timer” ([DS70005159](#))
- “Capture/Compare/PWM/Timer (MCCP and SCCP)” ([DS30003035](#))
- “Serial Peripheral Interface (SPI) with Audio Codec Support” ([DS70005136](#))
- “Inter-Integrated Circuit (I²C)” ([DS70000195](#))
- “Universal Asynchronous Receiver Transmitter (UART)” ([DS70000582](#))
- “Enhanced Parallel Master Port (EPMP)” ([DS39730](#))
- “RTCC with Timestamp” ([DS70005193](#))
- “32-Bit Programmable Cyclic Redundancy Check (CRC)” ([DS30009729](#))
- “Configurable Logic Cell (CLC)” ([DS70005298](#))
- “12-Bit A/D Converter with Threshold Detect” ([DS39739](#))
- “Scalable Comparator Module” ([DS39734](#))
- “Dual Comparator Module” ([DS39710](#))
- “Charge Time Measurement Unit (CTMU) and CTMU Operation with Threshold Detect” ([DS30009743](#))
- “High-Level Integration with Programmable High/Low-Voltage Detect (HLVD)” ([DS39725](#))
- “Watchdog Timer (WDT)” ([DS39697](#))
- “CodeGuard™ Intermediate Security” ([DS70005182](#))
- “High-Level Device Integration” ([DS39719](#))
- “Programming and Diagnostics” ([DS39716](#))
- “Comparator Voltage Reference Module” ([DS39709](#))

PIC24FJ256GA705 FAMILY

NOTES:

1.0 DEVICE OVERVIEW

This document contains device-specific information for the following devices:

- PIC24FJ64GA705
- PIC24FJ128GA705
- PIC24FJ256GA705
- PIC24FJ64GA704
- PIC24FJ128GA704
- PIC24FJ256GA704
- PIC24FJ64GA702
- PIC24FJ128GA702
- PIC24FJ256GA702

The PIC24FJ256GA705 family introduces large Flash and SRAM memory in smaller package sizes. This is a 16-bit microcontroller family with a broad peripheral feature set and enhanced computational performance. This family also offers a new migration option for those high-performance applications which may be outgrowing their 8-bit platforms, but do not require the numerical processing power of a Digital Signal Processor (DSP).

Table 1-3 lists the functions of the various pins shown in the pinout diagrams.

1.1 Core Features

1.1.1 16-BIT ARCHITECTURE

Central to all PIC24F devices is the 16-bit modified Harvard architecture, first introduced with Microchip's dsPIC[®] Digital Signal Controllers (DSCs). The PIC24F CPU core offers a wide range of enhancements, such as:

- 16-bit data and 24-bit address paths with the ability to move information between data and memory spaces
- Linear addressing of up to 12 Mbytes (program space) and 32 Kbytes (data)
- A 16-element Working register array with built-in software stack support
- A 17 x 17 hardware multiplier with support for integer math
- Hardware support for 32 by 16-bit division
- An instruction set that supports multiple addressing modes and is optimized for high-level languages, such as 'C'
- Operational performance up to 16 MIPS

1.1.2 POWER-SAVING TECHNOLOGY

The PIC24FJ256GA705 family of devices includes Retention Sleep, a low-power mode with essential circuits being powered from a separate low-voltage regulator.

This new low-power mode also supports the continuous operation of the low-power, on-chip Real-Time Clock/Calendar (RTCC), making it possible for an application to keep time while the device is otherwise asleep.

Aside from this new feature, PIC24FJ256GA705 family devices also include all of the legacy power-saving features of previous PIC24F microcontrollers, such as:

- On-the-Fly Clock Switching, allowing the selection of a lower power clock during run time
- Doze Mode Operation, for maintaining peripheral clock speed while slowing the CPU clock
- Instruction-Based Power-Saving Modes, for quick invocation of the Idle and Sleep modes

1.1.3 OSCILLATOR OPTIONS AND FEATURES

All of the devices in the PIC24FJ256GA705 family offer six different oscillator options, allowing users a range of choices in developing application hardware. These include:

- Two Crystal modes
- External Clock (EC) mode
- A Phase-Locked Loop (PLL) frequency multiplier, which allows processor speeds up to 32 MHz
- An internal Fast RC Oscillator (FRC), a nominal 8 MHz output with multiple frequency divider options
- A separate internal Low-Power RC Oscillator (LPRC), 31 kHz nominal for low-power, timing-insensitive applications.

The internal oscillator block also provides a stable reference source for the Fail-Safe Clock Monitor (FSCM). This option constantly monitors the main clock source against a reference signal provided by the internal oscillator and enables the controller to switch to the internal oscillator, allowing for continued low-speed operation or a safe application shutdown.

1.1.4 EASY MIGRATION

Regardless of the memory size, all devices share the same rich set of peripherals, allowing for a smooth migration path as applications grow and evolve. The consistent pinout scheme used throughout the entire family also aids in migrating from one device to the next larger device.

The PIC24F family is pin-compatible with devices in the dsPIC33 family, and shares some compatibility with the pinout schema for PIC18 and dsPIC30. This extends the ability of applications to grow from the relatively simple, to the powerful and complex, yet still selecting a Microchip device.

PIC24FJ256GA705 FAMILY

1.2 DMA Controller

PIC24FJ256GA705 family devices have a Direct Memory Access (DMA) Controller. This module acts in concert with the CPU, allowing data to move between data memory and peripherals without the intervention of the CPU, increasing data throughput and decreasing execution time overhead. Six independently programmable channels make it possible to service multiple peripherals at virtually the same time, with each channel peripheral performing a different operation. Many types of data transfer operations are supported.

1.3 Other Special Features

- **Peripheral Pin Select:** The Peripheral Pin Select (PPS) feature allows most digital peripherals to be mapped over a fixed set of digital I/O pins. Users may independently map the input and/or output of any one of the many digital peripherals to any one of the I/O pins.
- **Configurable Logic Cell:** The Configurable Logic Cell (CLC) module allows the user to specify combinations of signals as inputs to a logic function and to use the logic output to control other peripherals or I/O pins.
- **Timing Modules:** The PIC24FJ256GA705 family provides three independent, general purpose, 16-bit timers (two of which can be combined into a 32-bit timer). The devices also include four multiple output advanced Capture/Compare/PWM/Timer peripherals, and three independent legacy Input Capture and three independent legacy Output Compare modules.
- **Communications:** The PIC24FJ256GA705 family incorporates a range of serial communication peripherals to handle a range of application requirements. There are two independent I²C modules that support both Master and Slave modes of operation. Devices also have, through the PPS feature, two independent UARTs with built-in IrDA[®] encoders/decoders and three SPI modules.
- **Analog Features:** All members of the PIC24FJ256GA705 family include a 12-bit A/D Converter (A/D) module and a triple comparator module. The A/D module incorporates a range of new features that allow the converter to assess and make decisions on incoming data, reducing CPU overhead for routine A/D conversions. The comparator module includes three analog comparators that are configurable for a wide range of operations.
- **CTMU Interface:** In addition to their other analog features, members of the PIC24FJ256GA705 family include the CTMU interface module. This provides a convenient method for precision time measurement and pulse generation, and can serve as an interface for capacitive sensors.

- **Enhanced Parallel Master/Parallel Slave Port:** This module allows rapid and transparent access to the microcontroller data bus, and enables the CPU to directly address external data memory. The parallel port can function in Master or Slave mode, accommodating data widths of four or eight bits and address widths of up to ten bits in Master modes.
- **Real-Time Clock and Calendar (RTCC):** This module implements a full-featured clock and calendar with alarm functions in hardware, freeing up timer resources and program memory space for use of the core application.

1.4 Details on Individual Family Members

Devices in the PIC24FJ256GA705 family are available in 28-pin, 44-pin and 48-pin packages. The general block diagram for all devices is shown in [Figure 1-1](#).

The devices are differentiated from each other in five ways:

1. Flash program memory (64 Kbytes for PIC24FJ64GA70X devices, 128 Kbytes for PIC24FJ128GA70X devices, 256 Kbytes for PIC24FJ256GA70X devices).
2. Available I/O pins and ports (22 pins on two ports for 28-pin devices, and 36 and 40 pins on three ports for 44-pin/48-pin devices).
3. Enhanced Parallel Master Port (EPMP) is only available on 44-pin/48-pin devices.
4. Analog input channels (10 channels for 28-pin devices and 14 channels for 44-pin/48-pin devices).
5. CTMU input channels (12 channels for 28-pin devices and 13 channels for 44-pin/48-pin devices)

All other features for devices in this family are identical. These are summarized in [Table 1-1](#) and [Table 1-2](#).

A list of the pin features available on the PIC24FJ256GA705 family devices, sorted by function, is shown in [Table 1-3](#). Note that this table shows the pin location of individual peripheral features and not how they are multiplexed on the same pin. This information is provided in the pinout diagrams in the beginning of this data sheet. Multiplexed features are sorted by the priority given to a feature, with the highest priority peripheral being listed first.

PIC24FJ256GA705 FAMILY

TABLE 1-1: DEVICE FEATURES FOR THE PIC24FJXXXGA702: 28-PIN DEVICES

Features	PIC24FJ64GA702	PIC24FJ128GA702	PIC24FJ256GA702
Operating Frequency	DC – 32 MHz		
Program Memory (bytes)	64K	128K	256K
Program Memory (instruction words, 24 bits)	22,528	45,056	88,064
Data Memory (bytes)	16K		
Interrupt Sources (soft vectors/NMI traps)	124		
I/O Ports	Ports A, B		
Total I/O Pins	22		
Remappable Pins	18 (18 I/Os, 0 inputs only)		
DMA	1 6-channel		
16-Bit Timers	3 ⁽¹⁾		
Real-Time Clock and Calendar (RTCC)	Yes		
Cyclic Redundancy Check (CRC)	Yes		
Input Capture Channels	3 ⁽¹⁾		
Output Compare/PWM Channels	3 ⁽¹⁾		
Input Change Notification Interrupt	21 (remappable pins)		
Serial Communications:			
UART	2 ⁽¹⁾		
SPI (three-wire/four-wire)	3 ⁽¹⁾		
I ² C	2		
Configurable Logic Cell (CLC)	2 ⁽¹⁾		
Parallel Communications (EPMP/PSP)	No		
Capture/Compare/PWM/Timer Modules	4 Multiple CCPs 1 (6-output), 3 (2-output)		
JTAG Boundary Scan	Yes		
10/12-Bit Analog-to-Digital Converter (A/D) Module (input channels)	10		
Analog Comparators	3		
CTMU Interface	Yes		
Universal Serial Bus Controller	No		
Resets (and Delays)	Core POR, V _{DD} POR, BOR, RESET Instruction, MCLR, WDT, Illegal Opcode, REPEAT Instruction, Hardware Traps, Configuration Word Mismatch (OST, PLL Lock)		
Instruction Set	76 Base Instructions, Multiple Addressing Mode Variations		
Packages	28-Pin QFN, UQFN, SOIC, SSOP and SPDIP ⁽²⁾		

Note 1: Some peripherals are accessible through remappable pins.

Note 2: 28-Pin SPDIP is available only in the highest Flash variant.

PIC24FJ256GA705 FAMILY

TABLE 1-2: DEVICE FEATURES FOR THE PIC24FJXXXGA70X: 44-PIN AND 48-PIN DEVICES

Features	PIC24FJ64GA70X	PIC24FJ128GA70X	PIC24FJ256GA70X
Operating Frequency	DC – 32 MHz		
Program Memory (bytes)	64K	128K	256K
Program Memory (instruction words, 24 bits)	22,528	45,056	88,064
Data Memory (bytes)	16K		
Interrupt Sources (soft vectors/NMI traps)	124		
I/O Ports	Ports A, B, C		
Total I/O Pins:			
44-pin	35	35	35
48-pin	39	39	39
Remappable Pins:			
44-pin	29 (29 I/Os, 0 inputs only)		
48-pin	33 (29 I/Os, 4 inputs only)		
DMA (6-channel)	1		
16-Bit Timers	3 ⁽¹⁾		
Real-Time Clock and Calendar (RTCC)	Yes		
Cyclic Redundancy Check (CRC)	Yes		
Input Capture Channels	3 ⁽¹⁾		
Output Compare/PWM Channels	3 ⁽¹⁾		
Input Change Notification Interrupt	25 (remappable pins)		
Serial Communications:			
UART	2 ⁽¹⁾		
SPI (three-wire/four-wire)	3 ⁽¹⁾		
I ² C	2		
Configurable Logic Cell (CLC)	2 ⁽¹⁾		
Parallel Communications (EPMP/PSP)	Yes		
Capture/Compare/PWM/Timer Modules (MCCP)	4 Modules 1 (6-output), 3 (2-output)		
JTAG Boundary Scan	Yes		
10/12-Bit Analog-to-Digital Converter (A/D) Module (input channels)	14		
Analog Comparators	3		
CTMU Interface	Yes		
Universal Serial Bus Controller	No		
Resets (and delays)	Core POR, V _{DD} POR, BOR, RESET Instruction, MCLR, WDT, Illegal Opcode, REPEAT Instruction, Hardware Traps, Configuration Word Mismatch (OST, PLL Lock)		
Instruction Set	76 Base Instructions, Multiple Addressing Mode Variations		
Packages	44-Pin TQFP, 48-Pin TQFP and UQFN		

Note 1: Some peripherals are accessible through remappable pins.

PIC24FJ256GA705 FAMILY

FIGURE 1-1: PIC24FJ256GA705 FAMILY GENERAL BLOCK DIAGRAM

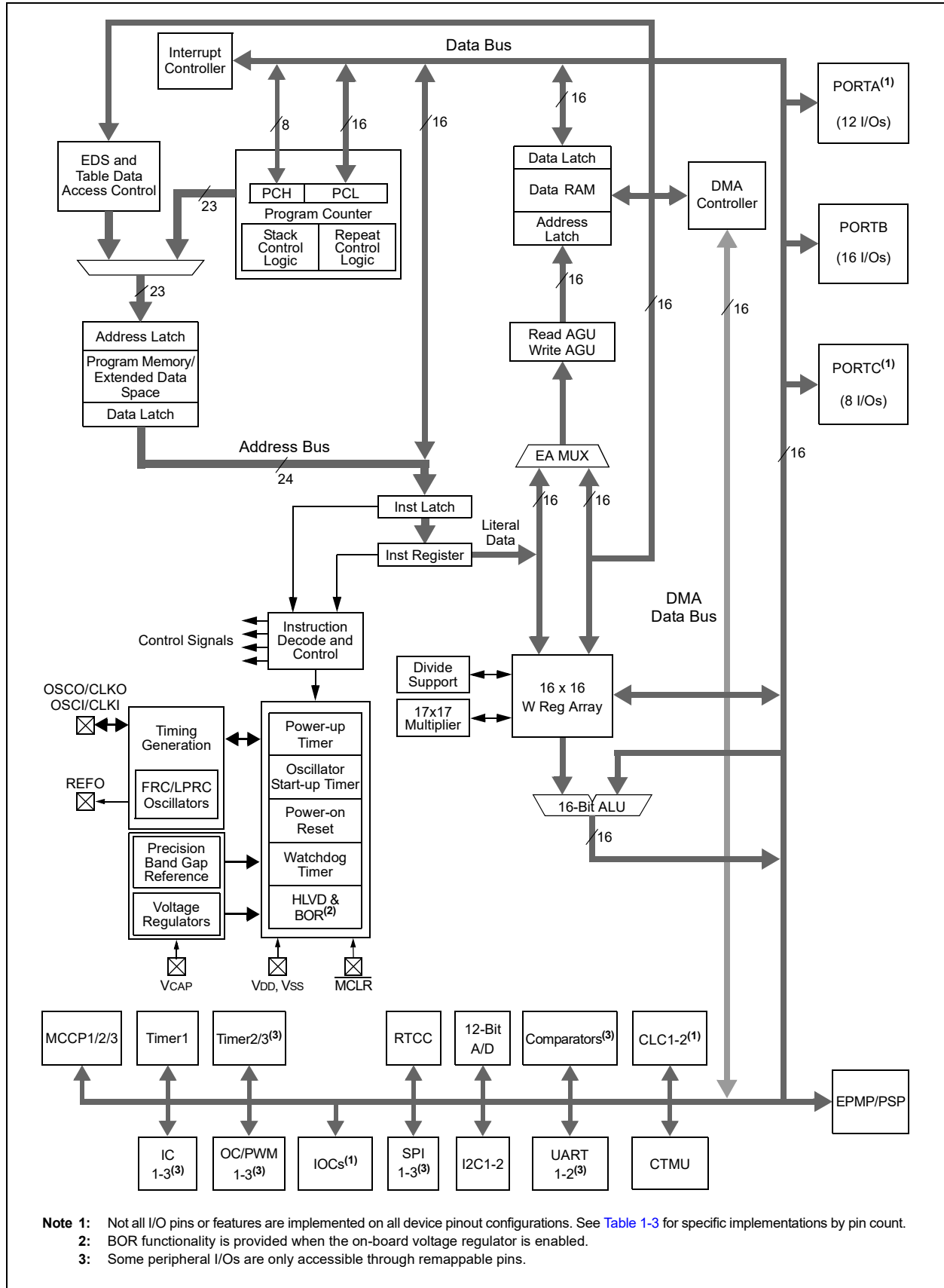

PIC24FJ256GA705 FAMILY

TABLE 1-3: PIC24FJ256GA705 FAMILY PINOUT DESCRIPTIONS

Pin Function	Pin Number/Grid Locator				I/O	Input Buffer	Description
	28-Pin SOIC, SSOP, SPDIP	28-Pin QFN, UQFN	44-Pin TQFP	48-Pin UQFN/TQFP			
AN0	2	27	19	21	I	ANA	A/D Analog Inputs
AN1	3	28	20	22	I	ANA	
AN2	4	1	21	23	I	ANA	
AN3	5	2	22	24	I	ANA	
AN4	6	3	23	25	I	ANA	
AN5	7	4	24	26	I	ANA	
AN6	25	22	14	15	I	ANA	
AN7	24	21	11	12	I	ANA	
AN8	23	20	10	11	I	ANA	
AN9	26	23	15	16	I	ANA	
AN10	—	—	25	27	I	ANA	
AN11	—	—	26	28	I	ANA	
AN12	—	—	27	29	I	ANA	
AN13	—	—	36	39	I	ANA	
AVDD	28	25	17	18	P	—	Positive Supply for Analog modules
AVSS	27	24	16	17	P	—	Ground Reference for Analog modules
C1INA	7	4	24	26	I	ANA	Comparator 1 Input A
C1INB	6	3	23	25	I	ANA	Comparator 1 Input B
C1INC	18, 24	15, 21	1, 11	1, 12	I	ANA	Comparator 1 Input C
C1IND	9	6	30	33	I	ANA	Comparator 1 Input D
C2INA	5	2	22	24	I	ANA	Comparator 2 Input A
C2INB	4	1	21	23	I	ANA	Comparator 2 Input B
C2INC	18	15	1	1	I	ANA	Comparator 2 Input C
C2IND	10	7	31	34	I	ANA	Comparator 2 Input D
C3INA	26	23	15	16	I	ANA	Comparator 3 Input A
C3INB	25	22	14	15	I	ANA	Comparator 3 Input B
C3INC	2, 18	15, 27	1, 19	1, 21	I	ANA	Comparator 3 Input C
C3IND	3	28	20	22	I	ANA	Comparator 3 Input D
CLKI	9	6	30	33	—	—	Main Clock Input Connection
CLKO	10	7	31	34	O	DIG	System Clock Output
CTCMP	4	1	21	23	O	ANA	CTMU Comparator 2 Input (Pulse mode)

Legend: TTL = TTL input buffer
ANA = Analog level input/output
DIG = Digital input/output

ST = Schmitt Trigger input buffer
I²C = I²C/SMBus input buffer
XCVR = Dedicated Transceiver

PIC24FJ256GA705 FAMILY

TABLE 1-3: PIC24FJ256GA705 FAMILY PINOUT DESCRIPTIONS (CONTINUED)

Pin Function	Pin Number/Grid Locator				I/O	Input Buffer	Description
	28-Pin SOIC, SSOP, SPDIP	28-Pin QFN, UQFN	44-Pin TQFP	48-Pin UQFN/TQFP			
CTED1	2	27	19	21	I	ST	CTMU External Edge Inputs
CTED2	3	28	20	22	I	ST	
CTED3	16	13	43	47	I	ST	
CTED4	18	15	1	1	I	ST	
CTED5	25	22	14	15	I	ST	
CTED6	26	23	15	16	I	ST	
CTED7	—	—	5	5	I	ST	
CTED8	7	4	24	26	I	ST	
CTED9	22	19	9	10	I	ST	
CTED10	17	14	44	48	I	ST	
CTED11	21	18	8	9	I	ST	
CTED12	5	2	22	24	I	ST	
CTED13	6	3	23	25	I	ST	
CTPLS	24	21	11	12	O	DIG	CTMU Pulse Output
CVREF	25	22	14	15	O	ANA	Comparator Voltage Reference Output
CVREF+	2	27	19	21	I	ANA	Comparator Voltage Reference (high) Input
CVREF-	3	28	20	22	I	ANA	Comparator Voltage Reference (low) Input
INT0	16	13	43	47	I	ST	External Interrupt Input 0
IOCA0	2	27	19	21	I	ST	PORTA Interrupt-on-Change
IOCA1	3	28	20	22	I	ST	
IOCA2	9	6	30	33	I	ST	
IOCA3	10	7	31	34	I	ST	
IOCA4	12	9	34	37	I	ST	
IOCA7	—	—	13	14	I	ST	
IOCA8	—	—	32	35	I	ST	
IOCA9	—	—	35	38	I	ST	
IOCA10	—	—	12	13	I	ST	
IOCA11	—	—	—	8	I	ST	
IOCA12	—	—	—	20	I	ST	
IOCA13	—	—	—	32	I	ST	
IOCA14	—	—	—	44	I	ST	

Legend: TTL = TTL input buffer ST = Schmitt Trigger input buffer
ANA = Analog level input/output I²C = I²C/SMBus input buffer
DIG = Digital input/output XCVR = Dedicated Transceiver

PIC24FJ256GA705 FAMILY

TABLE 1-3: PIC24FJ256GA705 FAMILY PINOUT DESCRIPTIONS (CONTINUED)

Pin Function	Pin Number/Grid Locator				I/O	Input Buffer	Description
	28-Pin SOIC, SSOP, SPDIP	28-Pin QFN, UQFN	44-Pin TQFP	48-Pin UQFN/TQFP			
IOCB0	4	1	21	23	I	ST	PORTB Interrupt-on-Change
IOCB1	5	2	22	24	I	ST	
IOCB2	6	3	23	25	I	ST	
IOCB3	7	4	24	26	I	ST	
IOCB4	11	8	33	36	I	ST	
IOCB5	14	11	41	45	I	ST	
IOCB6	15	12	42	46	I	ST	
IOCB7	16	13	43	47	I	ST	
IOCB8	17	14	44	48	I	ST	
IOCB9	18	15	1	1	I	ST	
IOCB10	21	18	8	9	I	ST	
IOCB11	22	19	9	10	I	ST	
IOCB12	23	20	10	11	I	ST	
IOCB13	24	21	11	12	I	ST	
IOCB14	25	22	14	15	I	ST	
IOCB15	26	23	15	16	I	ST	
IOCC1	—	—	26	28	I	ST	PORTC Interrupt-on-Change
IOCC2	—	—	27	29	I	ST	
IOCC3	—	—	36	39	I	ST	
IOCC4	—	—	37	40	I	ST	
IOCC5	—	—	38	41	I	ST	
IOCC6	—	—	2	2	I	ST	
IOCC7	—	—	3	3	I	ST	
IOCC8	—	—	4	4	I	ST	
IOCC9	—	—	5	5	I	ST	
LVDIN	23	20	10	11	I	ANA	High/Low-Voltage Detect
MCLR	1	26	18	19	I	ST	Master Clear (device Reset) Input. This line is brought low to cause a Reset.
OCM1A	16	13	43	47	O	DIG	MCCP1 Outputs
OCM1B	17	14	44	48	O	DIG	
OCM1C	21	18	8	9	O	DIG	
OCM1D	24	21	11	12	O	DIG	
OCM1E	14	11	41	45	O	DIG	
OCM1F	15	12	42	46	O	DIG	
OSCI	9	6	30	33	I	ANA/ST	Main Oscillator Input Connection
OSCO	10	7	31	34	O	ANA	Main Oscillator Output Connection

Legend: TTL = TTL input buffer
ANA = Analog level input/output
DIG = Digital input/output
ST = Schmitt Trigger input buffer
I²C = I²C/SMBus input buffer
XCVR = Dedicated Transceiver

PIC24FJ256GA705 FAMILY

TABLE 1-3: PIC24FJ256GA705 FAMILY PINOUT DESCRIPTIONS (CONTINUED)

Pin Function	Pin Number/Grid Locator				I/O	Input Buffer	Description
	28-Pin SOIC, SSOP, SPDIP	28-Pin QFN, UQFN	44-Pin TQFP	48-Pin UQFN/TQFP			
PGC1	5	2	22	24	I	ST	ICSP™ Programming Clock
PGC2	22	19	9	10	I	ST	
PGC3	15	12	42	46	I	ST	
PGD1	4	1	21	23	I/O	DIG/ST	ICSP Programming Data
PGD2	21	18	8	9	I/O	DIG/ST	
PGD3	14	11	41	45	I/O	DIG/ST	
PMA0	—	—	3	3	I/O	DIG/ST/TTL	Parallel Master Port Address[0]/ Address Latch Low
PMA1	—	—	2	2	I/O	DIG/ST/TTL	Parallel Master Port Address[1]/ Address Latch High
PMA2	—	—	12	13	I/O	DIG/ST/TTL	Parallel Master Port Address[2]
PMA3	—	—	38	41	I/O	DIG/ST/TTL	Parallel Master Port Address[3]
PMA4	—	—	37	40	I/O	DIG/ST/TTL	Parallel Master Port Address[4]
PMA5	—	—	4	4	I/O	DIG/ST/TTL	Parallel Master Port Address[5]
PMA6	—	—	5	5	I/O	DIG/ST/TTL	Parallel Master Port Address[6]
PMA7	—	—	13	14	I/O	DIG/ST/TTL	Parallel Master Port Address[7]
PMA8	—	—	32	35	I/O	DIG/ST/TTL	Parallel Master Port Address[8]
PMA9	—	—	35	38	I/O	DIG/ST/TTL	Parallel Master Port Address[9]
PMA14/PMCS/PMCS1	—	—	15	16	I/O	DIG/ST/TTL	Parallel Master Port Address[14]/ Slave Chip Select/Chip Select 1 Strobe

Legend: TTL = TTL input buffer
ANA = Analog level input/output
DIG = Digital input/output
ST = Schmitt Trigger input buffer
I²C = I²C/SMBus input buffer
XCVR = Dedicated Transceiver

PIC24FJ256GA705 FAMILY

TABLE 1-3: PIC24FJ256GA705 FAMILY PINOUT DESCRIPTIONS (CONTINUED)

Pin Function	Pin Number/Grid Locator				I/O	Input Buffer	Description
	28-Pin SOIC, SSOP, SPDIP	28-Pin QFN, UQFN	44-Pin TQFP	48-Pin UQFN/TQFP			
PMD0	—	—	10	11	I/O	DIG/ST/TTL	Parallel Master Port Data (Demultiplexed Master mode) or Address/Data (Multiplexed Master modes)
PMD1	—	—	9	10	I/O	DIG/ST/TTL	
PMD2	—	—	8	9	I/O	DIG/ST/TTL	
PMD3	—	—	1	1	I/O	DIG/ST/TTL	
PMD4	—	—	44	48	I/O	DIG/ST/TTL	
PMD5	—	—	43	47	I/O	DIG/ST/TTL	
PMD6	—	—	42	46	I/O	DIG/ST/TTL	
PMD7	—	—	41	45	I/O	DIG/ST/TTL	
PMRD/ $\overline{\text{PMWR}}$	—	—	11	12	I/O	DIG/ST/TTL	Parallel Master Port Read Strobe/Write Strobe
PMWR/PMENB	—	—	14	15	I/O	DIG/ST/TTL	Parallel Master Port Write Strobe/Enable Strobe
PWRGT	—	—	—	—	O	DIG	Real-Time Clock Power Control Output
PWRLCLK	12	9	34	37	I	ST	Real-Time Clock 50/60 Hz Clock Input

Legend: TTL = TTL input buffer
ANA = Analog level input/output
DIG = Digital input/output
ST = Schmitt Trigger input buffer
I²C = I²C/SMBus input buffer
XCVR = Dedicated Transceiver

PIC24FJ256GA705 FAMILY

TABLE 1-3: PIC24FJ256GA705 FAMILY PINOUT DESCRIPTIONS (CONTINUED)

Pin Function	Pin Number/Grid Locator				I/O	Input Buffer	Description
	28-Pin SOIC, SSOP, SPDIP	28-Pin QFN, UQFN	44-Pin TQFP	48-Pin UQFN/TQFP			
RA0	2	27	19	21	I/O	DIG/ST	PORTA Digital I/Os
RA1	3	28	20	22	I/O	DIG/ST	
RA2	9	6	30	33	I/O	DIG/ST	
RA3	10	7	31	34	I/O	DIG/ST	
RA4	12	9	34	37	I/O	DIG/ST	
RA7	—	—	13	14	I/O	DIG/ST	
RA8	—	—	32	35	I/O	DIG/ST	
RA9	—	—	35	38	I/O	DIG/ST	
RA10	—	—	12	13	I/O	DIG/ST	
RA11	—	—	—	8	I/O	DIG/ST	
RA12	—	—	—	20	I/O	DIG/ST	
RA13	—	—	—	32	I/O	DIG/ST	
RA14	—	—	—	44	I/O	DIG/ST	
RB0	4	1	21	23	I/O	DIG/ST	
RB1	5	2	22	24	I/O	DIG/ST	
RB2	6	3	23	25	I/O	DIG/ST	
RB3	7	4	24	26	I/O	DIG/ST	
RB4	11	8	33	36	I/O	DIG/ST	
RB5	14	11	41	45	I/O	DIG/ST	
RB6	15	12	42	46	I/O	DIG/ST	
RB7	16	13	43	47	I/O	DIG/ST	
RB8	17	14	44	48	I/O	DIG/ST	
RB9	18	15	1	1	I/O	DIG/ST	
RB10	21	18	8	9	I/O	DIG/ST	
RB11	22	19	9	10	I/O	DIG/ST	
RB12	23	20	10	11	I/O	DIG/ST	
RB13	24	21	11	12	I/O	DIG/ST	
RB14	25	22	14	15	I/O	DIG/ST	
RB15	26	23	15	16	I/O	DIG/ST	
RC0	—	—	25	27	I/O	DIG/ST	PORTC Digital I/Os
RC1	—	—	26	28	I/O	DIG/ST	
RC2	—	—	27	29	I/O	DIG/ST	
RC3	—	—	36	39	I/O	DIG/ST	
RC4	—	—	37	40	I/O	DIG/ST	
RC5	—	—	38	41	I/O	DIG/ST	
RC6	—	—	2	2	I/O	DIG/ST	
RC7	—	—	3	3	I/O	DIG/ST	
RC8	—	—	4	4	I/O	DIG/ST	
RC9	—	—	5	5	I/O	DIG/ST	

Legend: TTL = TTL input buffer
ANA = Analog level input/output
DIG = Digital input/output

ST = Schmitt Trigger input buffer
I²C = I²C/SMBus input buffer
XCVR = Dedicated Transceiver

PIC24FJ256GA705 FAMILY

TABLE 1-3: PIC24FJ256GA705 FAMILY PINOUT DESCRIPTIONS (CONTINUED)

Pin Function	Pin Number/Grid Locator				I/O	Input Buffer	Description
	28-Pin SOIC, SSOP, SPDIP	28-Pin QFN, UQFN	44-Pin TQFP	48-Pin UQFN/TQFP			
RP0	4	1	21	23	I/O	DIG/ST	Remappable Peripherals (input or output)
RP1	5	2	22	24	I/O	DIG/ST	
RP2	6	3	23	25	I/O	DIG/ST	
RP3	7	4	24	26	I/O	DIG/ST	
RP4	11	8	33	36	I/O	DIG/ST	
RP5	14	11	41	45	I/O	DIG/ST	
RP6	15	12	42	46	I/O	DIG/ST	
RP7	16	13	43	47	I/O	DIG/ST	
RP8	17	14	44	48	I/O	DIG/ST	
RP9	18	15	1	1	I/O	DIG/ST	
RP10	21	18	8	9	I/O	DIG/ST	
RP11	22	19	9	10	I/O	DIG/ST	
RP12	23	20	10	11	I/O	DIG/ST	
RP13	24	21	11	12	I/O	DIG/ST	
RP14	25	22	14	15	I/O	DIG/ST	
RP15	26	23	15	16	I/O	DIG/ST	
RP16	—	—	25	27	I/O	DIG/ST	
RP17	—	—	26	28	I/O	DIG/ST	
RP18	—	—	27	29	I/O	DIG/ST	
RP19	—	—	36	39	I/O	DIG/ST	
RP20	—	—	37	40	I/O	DIG/ST	
RP21	—	—	38	41	I/O	DIG/ST	
RP22	—	—	2	2	I/O	DIG/ST	
RP23	—	—	3	3	I/O	DIG/ST	
RP24	—	—	4	4	I/O	DIG/ST	
RP25	—	—	5	5	I/O	DIG/ST	
RP26	2	27	19	21	I/O	DIG/ST	
RP27	3	28	20	22	I/O	DIG/ST	
RP28	—	—	12	13	I/O	DIG/ST	
RPI29	—	—	—	8	I	DIG/ST	Remappable Peripherals (input only)
RPI30	—	—	—	20	I	DIG/ST	
RPI31	—	—	—	32	I	DIG/ST	
RPI32	—	—	—	44	I	DIG/ST	

Legend: TTL = TTL input buffer
ANA = Analog level input/output
DIG = Digital input/output

ST = Schmitt Trigger input buffer
I²C = I²C/SMBus input buffer
XCVR = Dedicated Transceiver

PIC24FJ256GA705 FAMILY

NOTES:

2.0 GUIDELINES FOR GETTING STARTED WITH 16-BIT MICROCONTROLLERS

2.1 Basic Connection Requirements

Getting started with the PIC24FJ256GA705 family of 16-bit microcontrollers requires attention to a minimal set of device pin connections before proceeding with development.

The following pins must always be connected:

- All VDD and VSS pins (see [Section 2.2 “Power Supply Pins”](#))
- All AVDD and AVSS pins, regardless of whether or not the analog device features are used (see [Section 2.2 “Power Supply Pins”](#))
- MCLR pin (see [Section 2.3 “Master Clear \(MCLR\) Pin”](#))
- VCAP pin (see [Section 2.4 “Voltage Regulator Pin \(VCAP\)”](#))

These pins must also be connected if they are being used in the end application:

- PGCx/PGDx pins used for In-Circuit Serial Programming™ (ICSP™) and debugging purposes (see [Section 2.5 “ICSP Pins”](#))
- OSCI and OSCO pins when an external oscillator source is used (see [Section 2.6 “External Oscillator Pins”](#))

Additionally, the following pins may be required:

- VREF+/VREF- pins used when external voltage reference for analog modules is implemented

Note: The AVDD and AVSS pins must always be connected, regardless of whether any of the analog modules are being used.

The minimum mandatory connections are shown in [Figure 2-1](#).

FIGURE 2-1: RECOMMENDED MINIMUM CONNECTIONS

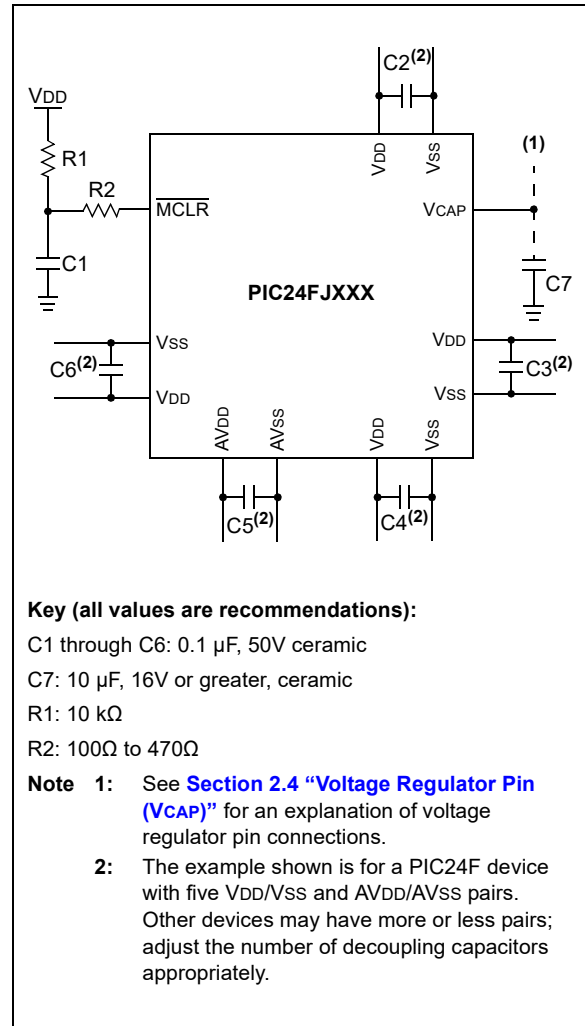

PIC24FJ256GA705 FAMILY

2.2 Power Supply Pins

2.2.1 DECOUPLING CAPACITORS

The use of decoupling capacitors on every pair of power supply pins, such as VDD, VSS, AVDD and AVSS, is required.

Consider the following criteria when using decoupling capacitors:

- **Value and type of capacitor:** A 0.1 μF (100 nF), 25V-50V capacitor is recommended. The capacitor should be a low-ESR device with a self-resonance frequency in the range of 200 MHz and higher. Ceramic capacitors are recommended.
- **Placement on the printed circuit board:** The decoupling capacitors should be placed as close to the pins as possible. It is recommended to place the capacitors on the same side of the board as the device. If space is constricted, the capacitor can be placed on another layer on the PCB using a via; however, ensure that the trace length from the pin to the capacitor is no greater than 0.25 inch (6 mm).
- **Handling high-frequency noise:** If the board is experiencing high-frequency noise (upward of tens of MHz), add a second ceramic-type capacitor in parallel to the above described decoupling capacitor. The value of the second capacitor can be in the range of 0.01 μF to 0.001 μF . Place this second capacitor next to each primary decoupling capacitor. In high-speed circuit designs, consider implementing a decade pair of capacitances as close to the power and ground pins as possible (e.g., 0.1 μF in parallel with 0.001 μF).
- **Maximizing performance:** On the board layout from the power supply circuit, run the power and return traces to the decoupling capacitors first, and then to the device pins. This ensures that the decoupling capacitors are first in the power chain. Equally important is to keep the trace length between the capacitor and the power pins to a minimum, thereby reducing PCB trace inductance.

2.2.2 BULK CAPACITORS

On boards with power traces running longer than six inches in length, it is suggested to use a bulk capacitance of 10 μF or greater located near the MCU. The value of the capacitor should be determined based on the trace resistance that connects the power supply source to the device, and the maximum current drawn by the device in the application. Typical values range from 10 μF to 47 μF . The capacitor should be ceramic and have a voltage rating of 25V or more to reduce DC bias effects (see [Section 2.4.1 “Considerations for Ceramic Capacitors”](#)).

2.3 Master Clear ($\overline{\text{MCLR}}$) Pin

The $\overline{\text{MCLR}}$ pin provides two specific device functions: device Reset, and device programming and debugging. If programming and debugging are not required in the end application, a direct connection to VDD may be all that is required. The addition of other components, to help increase the application's resistance to spurious Resets from voltage sags, may be beneficial. A typical configuration is shown in [Figure 2-1](#). Other circuit designs may be implemented depending on the application's requirements.

During programming and debugging, the resistance and capacitance that can be added to the pin must be considered. Device programmers and debuggers drive the $\overline{\text{MCLR}}$ pin. Consequently, specific voltage levels (V_{IH} and V_{IL}) and fast signal transitions must not be adversely affected. Therefore, specific values of R1 and C1 will need to be adjusted based on the application and PCB requirements. For example, it is recommended that the capacitor, C1, be isolated from the $\overline{\text{MCLR}}$ pin during programming and debugging operations by using a jumper ([Figure 2-2](#)). The jumper is replaced for normal run-time operations.

Any components associated with the $\overline{\text{MCLR}}$ pin should be placed within 0.25 inch (6 mm) of the pin.

FIGURE 2-2: EXAMPLE OF $\overline{\text{MCLR}}$ PIN CONNECTIONS

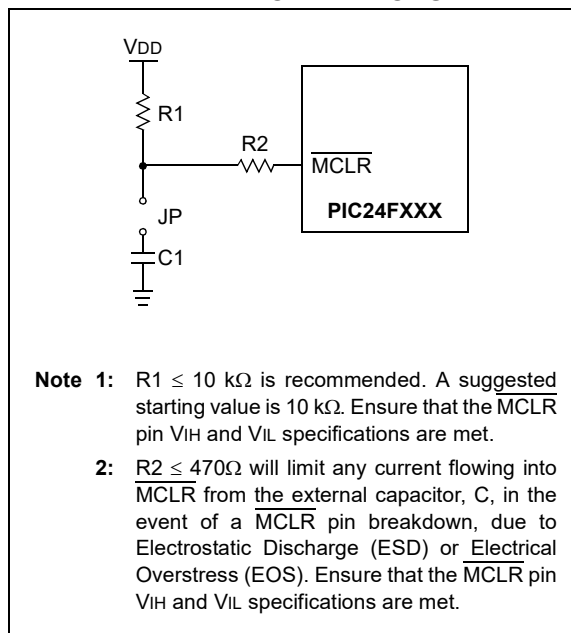

2.4 Voltage Regulator Pin (VCAP)

Note: This section applies only to PIC24FJ devices with an on-chip voltage regulator.

Refer to [Section 29.3 “On-Chip Voltage Regulator”](#) for details on connecting and using the on-chip regulator.

A low-ESR ($< 5\Omega$) capacitor is required on the VCAP pin to stabilize the voltage regulator output voltage. The VCAP pin must not be connected to VDD and must use a capacitor of 10 μF connected to ground. The type can be ceramic or tantalum. Suitable examples of capacitors are shown in [Table 2-1](#). Capacitors with equivalent specifications can be used.

Designers may use [Figure 2-3](#) to evaluate the ESR equivalence of candidate devices.

The placement of this capacitor should be close to VCAP. It is recommended that the trace length not exceed 0.25 inch (6 mm). Refer to [Section 32.0 “Electrical Characteristics”](#) for additional information.

FIGURE 2-3: FREQUENCY vs. ESR PERFORMANCE FOR SUGGESTED VCAP

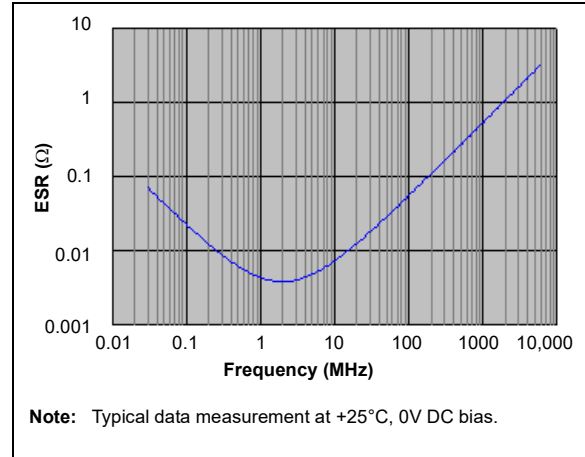

TABLE 2-1: SUITABLE CAPACITOR EQUIVALENTS (0805 CASE SIZE)

Make	Part #	Nominal Capacitance	Base Tolerance	Rated Voltage
TDK	C2012X5R1E106K085AC	10 μF	$\pm 10\%$	25V
TDK	C2012X5R1C106K085AC	10 μF	$\pm 10\%$	16V
Kemet	C0805C106M4PACTU	10 μF	$\pm 10\%$	16V
Murata	GRM21BR61E106KA3L	10 μF	$\pm 10\%$	25V
Murata	GRM21BR61C106KE15	10 μF	$\pm 10\%$	16V

PIC24FJ256GA705 FAMILY

2.4.1 CONSIDERATIONS FOR CERAMIC CAPACITORS

In recent years, large value, low-voltage, surface-mount ceramic capacitors have become very cost effective in sizes up to a few tens of microfarad. The low-ESR, small physical size and other properties make ceramic capacitors very attractive in many types of applications.

Ceramic capacitors are suitable for use with the internal voltage regulator of this microcontroller. However, some care is needed in selecting the capacitor to ensure that it maintains sufficient capacitance over the intended operating range of the application.

Typical low-cost, 10 μF ceramic capacitors are available in X5R, X7R and Y5V dielectric ratings (other types are also available, but are less common). The initial tolerance specifications for these types of capacitors are often specified as $\pm 10\%$ to $\pm 20\%$ (X5R and X7R) or -20% / $+80\%$ (Y5V). However, the effective capacitance that these capacitors provide in an application circuit will also vary based on additional factors, such as the applied DC bias voltage and the temperature. The total in-circuit tolerance is, therefore, much wider than the initial tolerance specification.

The X5R and X7R capacitors typically exhibit satisfactory temperature stability (ex: $\pm 15\%$ over a wide temperature range, but consult the manufacturer's data sheets for exact specifications). However, Y5V capacitors typically have extreme temperature tolerance specifications of $+22\%$ / -82% . Due to the extreme temperature tolerance, a 10 μF nominal rated Y5V type capacitor may not deliver enough total capacitance to meet minimum internal voltage regulator stability and transient response requirements. Therefore, Y5V capacitors are not recommended for use with the internal regulator if the application must operate over a wide temperature range.

In addition to temperature tolerance, the effective capacitance of large value ceramic capacitors can vary substantially, based on the amount of DC voltage applied to the capacitor. This effect can be very significant, but is often overlooked or is not always documented.

A typical DC bias voltage vs. capacitance graph for X7R type capacitors is shown in [Figure 2-4](#).

FIGURE 2-4: DC BIAS VOLTAGE vs. CAPACITANCE CHARACTERISTICS

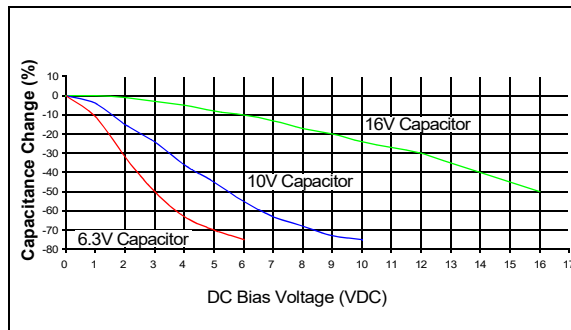

When selecting a ceramic capacitor to be used with the internal voltage regulator, it is suggested to select a high-voltage rating so that the operating voltage is a small percentage of the maximum rated capacitor voltage. For example, choose a ceramic capacitor rated at a minimum of 16V for the 1.8V core voltage. Suggested capacitors are shown in [Table 2-1](#).

2.5 ICSP Pins

The PGCx and PGDx pins are used for In-Circuit Serial Programming (ICSP) and debugging purposes. It is recommended to keep the trace length between the ICSP connector and the ICSP pins on the device as short as possible. If the ICSP connector is expected to experience an ESD event, a series resistor is recommended, with the value in the range of a few tens of ohms, not to exceed 100 Ω .

Pull-up resistors, series diodes and capacitors on the PGCx and PGDx pins are not recommended as they will interfere with the programmer/debugger communications to the device. If such discrete components are an application requirement, they should be removed from the circuit during programming and debugging. Alternatively, refer to the AC/DC characteristics and timing requirements information in the respective device Flash programming specification for information on capacitive loading limits, and pin Voltage Input High (VIH) and Voltage Input Low (VIL) requirements.

For device emulation, ensure that the "Communication Channel Select" pins (i.e., PGCx/PGDx) programmed into the device match the physical connections for the ICSP to the Microchip debugger/emulator tool.

For more information on available Microchip development tools connection requirements, refer to [Section 30.0 "Development Support"](#).

2.6 External Oscillator Pins

Many microcontrollers have options for at least two oscillators: a high-frequency Primary Oscillator and a low-frequency Secondary Oscillator (refer to [Section 9.0 “Oscillator Configuration”](#) for details).

The oscillator circuit should be placed on the same side of the board as the device. Place the oscillator circuit close to the respective oscillator pins with no more than 0.5 inch (12 mm) between the circuit components and the pins. The load capacitors should be placed next to the oscillator itself, on the same side of the board.

Use a grounded copper pour around the oscillator circuit to isolate it from surrounding circuits. The grounded copper pour should be routed directly to the MCU ground. Do not run any signal traces or power traces inside the ground pour. Also, if using a two-sided board, avoid any traces on the other side of the board where the crystal is placed.

Layout suggestions are shown in [Figure 2-5](#). In-line packages may be handled with a single-sided layout that completely encompasses the oscillator pins. With fine-pitch packages, it is not always possible to completely surround the pins and components. A suitable solution is to tie the broken guard sections to a mirrored ground layer. In all cases, the guard trace(s) must be returned to ground.

In planning the application's routing and I/O assignments, ensure that adjacent port pins, and other signals in close proximity to the oscillator, are benign (i.e., free of high frequencies, short rise and fall times, and other similar noise).

For additional information and design guidance on oscillator circuits, please refer to these Microchip Application Notes, available at the corporate website (www.microchip.com):

- AN943, “*Practical PICmicro® Oscillator Analysis and Design*”
- AN949, “*Making Your Oscillator Work*”
- AN1798, “*Crystal Selection for Low-Power Secondary Oscillator*”

FIGURE 2-5: SUGGESTED PLACEMENT OF THE OSCILLATOR CIRCUIT

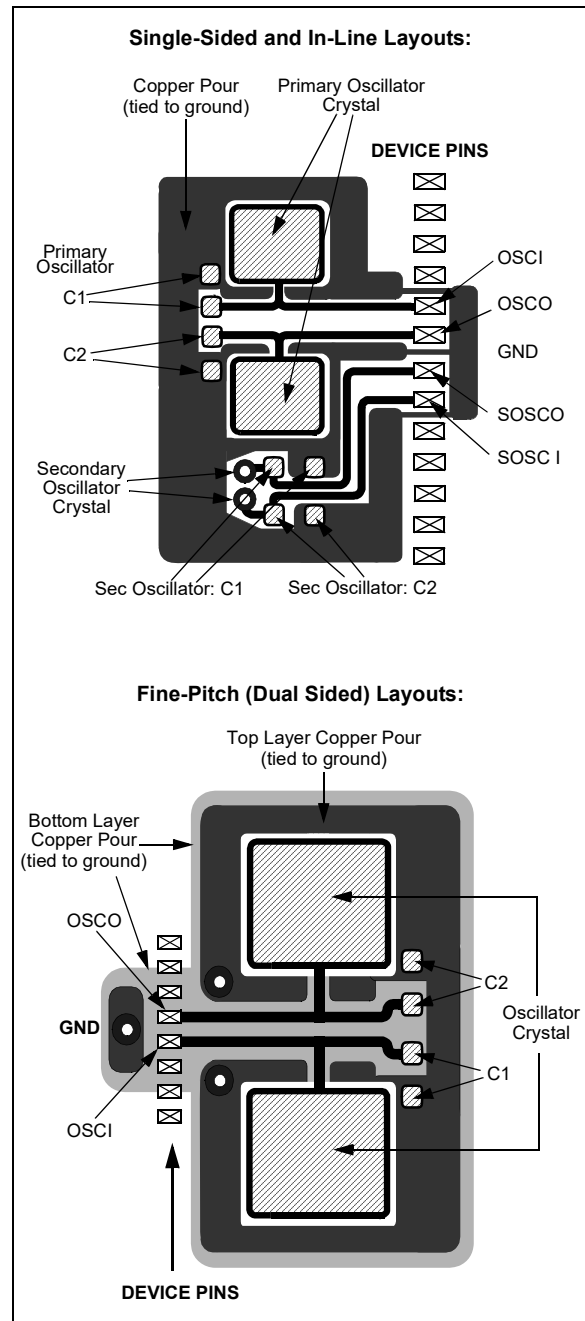

PIC24FJ256GA705 FAMILY

2.7 Configuration of Analog and Digital Pins During ICSP Operations

If an ICSP compliant emulator is selected as a debugger, it automatically initializes all of the A/D input pins (ANx) as “digital” pins. This is done by clearing all bits in the ANSx registers. Refer to [Section 11.2 “Configuring Analog Port Pins \(ANSx\)”](#) for more specific information.

The bits in these registers that correspond to the A/D pins that initialized the emulator must not be changed by the user application firmware; otherwise, communication errors will result between the debugger and the device.

If your application needs to use certain A/D pins as analog input pins during the debug session, the user application must modify the appropriate bits during initialization of the A/D module, as follows:

- Set the bits corresponding to the pin(s) to be configured as analog. Do not change any other bits, particularly those corresponding to the PGCx/PGDx pair, at any time.

When a Microchip debugger/emulator is used as a programmer, the user application firmware must correctly configure the ANSx registers. Automatic initialization of these registers is only done during debugger operation. Failure to correctly configure the register(s) will result in all A/D pins being recognized as analog input pins, resulting in the port value being read as a logic ‘0’, which may affect user application functionality.

2.8 Unused I/Os

Unused I/O pins should be configured as outputs and driven to a Logic Low state. Alternatively, connect a 1 k Ω to 10 k Ω resistor to Vss on unused pins and drive the output to logic low.

3.0 CPU

Note: This data sheet summarizes the features of this group of PIC24F devices. It is not intended to be a comprehensive reference source. For more information on the CPU, refer to “**CPU with Extended Data Space (EDS)**” (www.microchip.com/DS39732) in the “*dsPIC33/PIC24 Family Reference Manual*”. The information in this data sheet supersedes the information in the FRM.

The PIC24F CPU has a 16-bit (data) modified Harvard architecture with an enhanced instruction set and a 24-bit instruction word with a variable length opcode field. The Program Counter (PC) is 23 bits wide and addresses up to 4M instructions of user program memory space. A single-cycle instruction prefetch mechanism is used to help maintain throughput and provides predictable execution. All instructions execute in a single cycle, with the exception of instructions that change the program flow, the double-word move (MOV.D) instruction and the table instructions. Overhead-free program loop constructs are supported using the REPEAT instructions, which are interruptible at any point.

PIC24F devices have sixteen, 16-bit Working registers in the programmer’s model. Each of the Working registers can act as a Data, Address or Address Offset register. The 16th Working register (W15) operates as a Software Stack Pointer (SSP) for interrupts and calls.

The lower 32 Kbytes of the Data Space (DS) can be accessed linearly. The upper 32 Kbytes of the Data Space are referred to as Extended Data Space (EDS), to which the extended data RAM, EPMP memory space or program memory can be mapped.

The Instruction Set Architecture (ISA) has been significantly enhanced beyond that of the PIC18, but maintains an acceptable level of backward compatibility. All PIC18 instructions and addressing modes are supported, either directly, or through simple macros. Many of the ISA enhancements have been driven by compiler efficiency needs.

The core supports Inherent (no operand), Relative, Literal, Memory Direct Addressing modes along with three groups of addressing modes. All modes support Register Direct and various Register Indirect modes. Each group offers up to seven addressing modes. Instructions are associated with predefined addressing modes depending upon their functional requirements.

For most instructions, the core is capable of executing a data (or program data) memory read, a Working register (data) read, a data memory write and a program (instruction) memory read per instruction cycle. As a result, three parameter instructions can be supported, allowing trinary operations (for example, $A + B = C$) to be executed in a single cycle.

A high-speed, 17-bit x 17-bit multiplier has been included to significantly enhance the core arithmetic capability and throughput. The multiplier supports Signed, Unsigned and Mixed mode, 16-bit x 16-bit or 8-bit x 8-bit, integer multiplication. All multiply instructions execute in a single cycle.

The 16-bit ALU has been enhanced with integer divide assist hardware that supports an iterative non-restoring divide algorithm. It operates in conjunction with the REPEAT instruction looping mechanism and a selection of iterative divide instructions to support 32-bit (or 16-bit), divided by 16-bit, integer signed and unsigned division. All divide operations require 19 cycles to complete but are interruptible at any cycle boundary.

The PIC24F has a vectored exception scheme with up to eight sources of non-maskable traps and up to 118 interrupt sources. Each interrupt source can be assigned to one of seven priority levels.

A block diagram of the CPU is shown in [Figure 3-1](#).

3.1 Programmer’s Model

The programmer’s model for the PIC24F is shown in [Figure 3-2](#). All registers in the programmer’s model are memory-mapped and can be manipulated directly by instructions.

A description of each register is provided in [Table 3-1](#). All registers associated with the programmer’s model are memory-mapped.

PIC24FJ256GA705 FAMILY

FIGURE 3-1: PIC24F CPU CORE BLOCK DIAGRAM

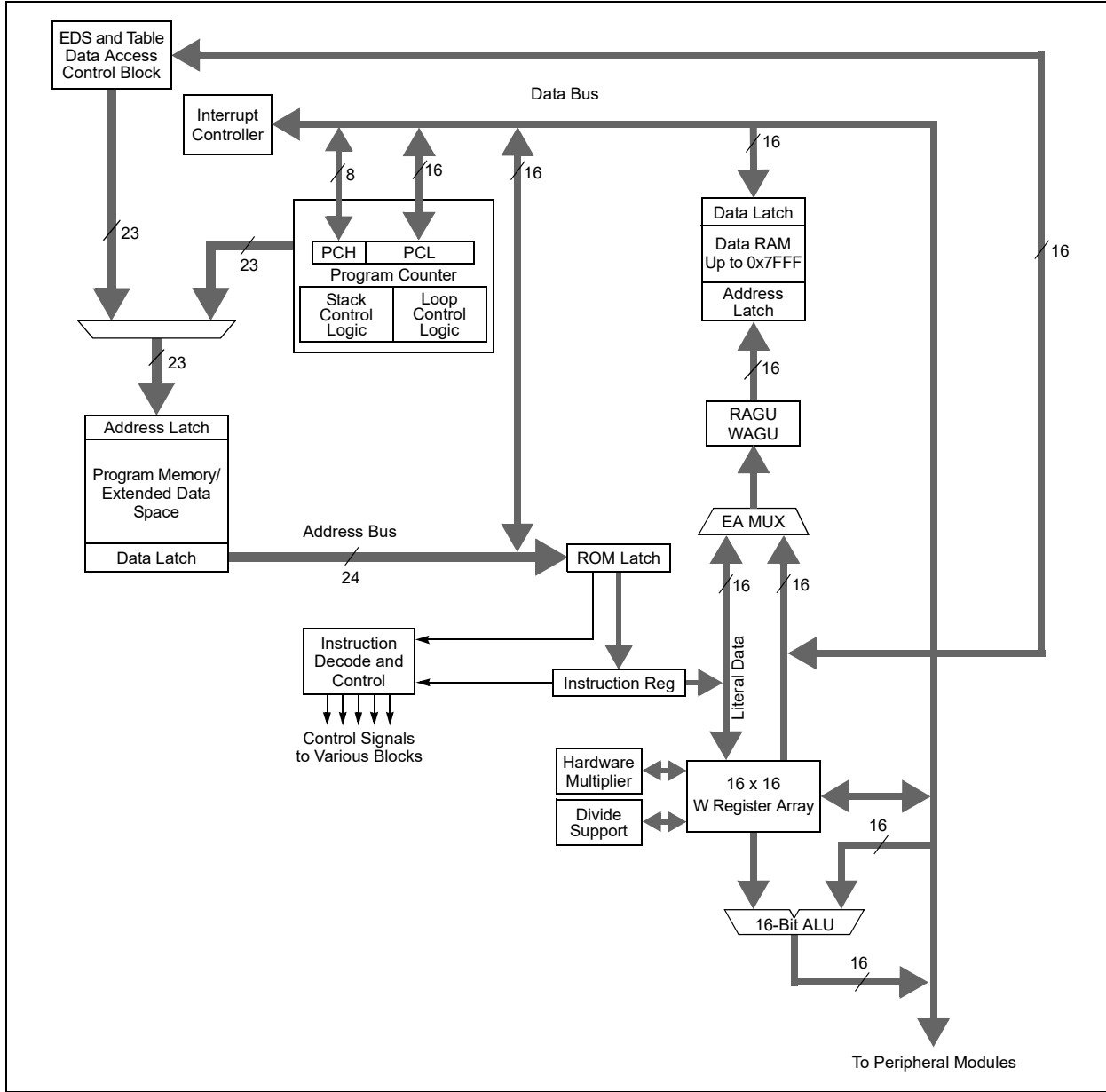
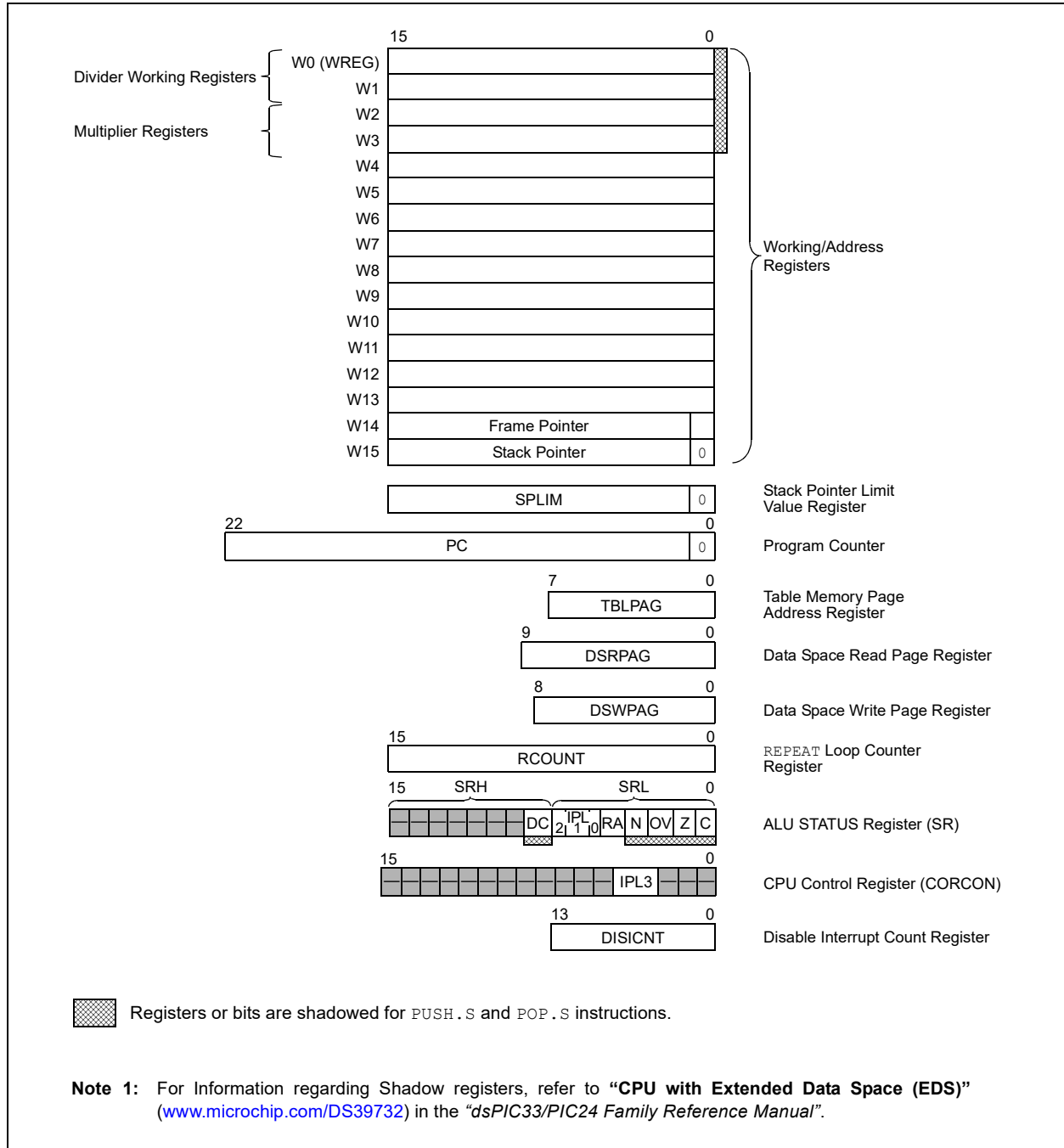

TABLE 3-1: CPU CORE REGISTERS

Register(s) Name	Description
W0 through W15	Working Register Array
PC	23-Bit Program Counter
SR	ALU STATUS Register
SPLIM	Stack Pointer Limit Value Register
TBLPAG	Table Memory Page Address Register
RCOUNT	REPEAT Loop Counter Register
CORCON	CPU Control Register
DISICNT	Disable Interrupt Count Register
DSRPAG	Data Space Read Page Register
DSWPAG	Data Space Write Page Register

FIGURE 3-2: PROGRAMMER'S MODEL



PIC24FJ256GA705 FAMILY

3.2 CPU Control Registers

REGISTER 3-1: SR: ALU STATUS REGISTER

U-0	U-0	U-0	U-0	U-0	U-0	U-0	R/W-0
—	—	—	—	—	—	—	DC
bit 15							bit 8

R/W-0 ⁽¹⁾	R/W-0 ⁽¹⁾	R/W-0 ⁽¹⁾	R-0	R/W-0	R/W-0	R/W-0	R/W-0
IPL2 ⁽²⁾	IPL1 ⁽²⁾	IPL0 ⁽²⁾	RA	N	OV	Z	C
bit 7							bit 0

Legend:

R = Readable bit

W = Writable bit

U = Unimplemented bit, read as '0'

-n = Value at POR

'1' = Bit is set

'0' = Bit is cleared

x = Bit is unknown

bit 15-9 **Unimplemented:** Read as '0'

bit 8 **DC:** ALU Half Carry/Borrow bit

1 = A carry out from the 4th low-order bit (for byte-sized data) or 8th low-order bit (for word-sized data) of the result occurred

0 = No carry out from the 4th or 8th low-order bit of the result has occurred

bit 7-5 **IPL[2:0]:** CPU Interrupt Priority Level Status bits^(1,2)

111 = CPU Interrupt Priority Level is 7 (15); user interrupts are disabled

110 = CPU Interrupt Priority Level is 6 (14)

101 = CPU Interrupt Priority Level is 5 (13)

100 = CPU Interrupt Priority Level is 4 (12)

011 = CPU Interrupt Priority Level is 3 (11)

010 = CPU Interrupt Priority Level is 2 (10)

001 = CPU Interrupt Priority Level is 1 (9)

000 = CPU Interrupt Priority Level is 0 (8)

bit 4 **RA:** REPEAT Loop Active bit

1 = REPEAT loop is in progress

0 = REPEAT loop is not in progress

bit 3 **N:** ALU Negative bit

1 = Result was negative

0 = Result was not negative (zero or positive)

bit 2 **OV:** ALU Overflow bit

1 = Overflow occurred for signed (two's complement) arithmetic in this arithmetic operation

0 = No overflow has occurred

bit 1 **Z:** ALU Zero bit

1 = An operation, which affects the Z bit, has set it at some time in the past

0 = The most recent operation, which affects the Z bit, has cleared it (i.e., a non-zero result)

bit 0 **C:** ALU Carry/Borrow bit

1 = A carry out from the Most Significant bit (MSb) of the result occurred

0 = No carry out from the Most Significant bit of the result occurred

Note 1: The IPLx Status bits are read-only when NSTDIS (INTCON1[15]) = 1.

Note 2: The IPLx Status bits are concatenated with the IPL3 Status bit (CORCON[3]) to form the CPU Interrupt Priority Level (IPL). The value in parentheses indicates the IPL when IPL3 = 1.

PIC24FJ256GA705 FAMILY

REGISTER 3-2: CORCON: CPU CORE CONTROL REGISTER

U-0	U-0	U-0	U-0	U-0	U-0	U-0	U-0
—	—	—	—	—	—	—	—
bit 15						bit 8	

U-0	U-0	U-0	U-0	R/C-0	R/W-1	U-0	U-0
—	—	—	—	IPL3 ⁽¹⁾	PSV ⁽²⁾	—	—
bit 7				bit 0			

Legend:	C = Clearable bit
R = Readable bit	W = Writable bit
-n = Value at POR	'1' = Bit is set
	'0' = Bit is cleared
	x = Bit is unknown

bit 15-4 **Unimplemented:** Read as '0'

bit 3 **IPL3:** CPU Interrupt Priority Level Status bit⁽¹⁾
 1 = CPU Interrupt Priority Level is greater than 7
 0 = CPU Interrupt Priority Level is 7 or less

bit 2 **PSV:** Program Space Visibility (PSV) in Data Space Enable⁽²⁾
 1 = Program space is visible in Data Space
 0 = Program space is not visible in Data Space

bit 1-0 **Unimplemented:** Read as '0'

- Note 1:** The IPL3 bit is concatenated with the IPL[2:0] bits (SR[7:5]) to form the CPU Interrupt Priority Level; see [Register 3-1](#) for bit description.
- 2:** If PSV = 0, any reads from data memory at 0x8000 and above will cause an address trap error instead of reading from the PSV section of program memory. This bit is not individually addressable.

PIC24FJ256GA705 FAMILY

3.3 Arithmetic Logic Unit (ALU)

The PIC24F ALU is 16 bits wide and is capable of addition, subtraction, bit shifts and logic operations. Unless otherwise mentioned, arithmetic operations are two's complement in nature. Depending on the operation, the ALU may affect the values of the Carry (C), Zero (Z), Negative (N), Overflow (OV) and Digit Carry (DC) Status bits in the SR register. The C and DC Status bits operate as Borrow and Digit Borrow bits, respectively, for subtraction operations.

The ALU can perform 8-bit or 16-bit operations, depending on the mode of the instruction that is used. Data for the ALU operation can come from the W register array, or data memory, depending on the addressing mode of the instruction. Likewise, output data from the ALU can be written to the W register array or a data memory location.

The PIC24F CPU incorporates hardware support for both multiplication and division. This includes a dedicated hardware multiplier and support hardware for 16-bit divisor division.

3.3.1 MULTIPLIER

The ALU contains a high-speed, 17-bit x 17-bit multiplier. It supports unsigned, signed or mixed sign operation in several multiplication modes:

- 16-bit x 16-bit signed
- 16-bit x 16-bit unsigned
- 16-bit signed x 5-bit (literal) unsigned
- 16-bit unsigned x 16-bit unsigned
- 16-bit unsigned x 5-bit (literal) unsigned
- 16-bit unsigned x 16-bit signed
- 8-bit unsigned x 8-bit unsigned

3.3.2 DIVIDER

The divide block supports 32-bit/16-bit and 16-bit/16-bit signed and unsigned integer divide operations with the following data sizes:

1. 32-bit signed/16-bit signed divide
2. 32-bit unsigned/16-bit unsigned divide
3. 16-bit signed/16-bit signed divide
4. 16-bit unsigned/16-bit unsigned divide

The quotient for all divide instructions ends up in W0 and the remainder in W1. The 16-bit signed and unsigned DIV instructions can specify any W register for both the 16-bit divisor (Wn), and any W register (aligned) pair (W(m + 1):Wm) for the 32-bit dividend. The divide algorithm takes one cycle per bit of divisor, so both 32-bit/16-bit and 16-bit/16-bit instructions take the same number of cycles to execute.

3.3.3 MULTIBIT SHIFT SUPPORT

The PIC24F ALU supports both single bit and single-cycle, multibit arithmetic and logic shifts. Multibit shifts are implemented using a shifter block, capable of performing up to a 15-bit arithmetic right shift, or up to a 15-bit left shift, in a single cycle. All multibit shift instructions only support Register Direct Addressing for both the operand source and result destination.

A full summary of instructions that use the shift operation is provided in [Table 3-2](#).

TABLE 3-2: INSTRUCTIONS THAT USE THE SINGLE BIT AND MULTIBIT SHIFT OPERATION

Instruction	Description
ASR	Arithmetic Shift Right Source register by one or more bits.
SL	Shift Left Source register by one or more bits.
LSR	Logical Shift Right Source register by one or more bits.

4.0 MEMORY ORGANIZATION

Note: This data sheet summarizes the features of this group of PIC24F devices. It is not intended to be a comprehensive reference source. For more information, refer to “**PIC24F Flash Program Memory**” (www.microchip.com/DS30009715) in the “*dsPIC33/PIC24 Family Reference Manual*”. The information in this data sheet supersedes the information in the FRM.

As Harvard architecture devices, PIC24F microcontrollers feature separate program and data memory spaces and buses. This architecture also allows direct access of program memory from the Data Space during code execution.

4.1 Program Memory Space

The program address memory space of the PIC24FJ256GA705 family devices is 4M instructions. The space is addressable by a 24-bit value derived from either the 23-bit Program Counter (PC) during program execution, or from table operation or Data Space remapping, as described in [Section 4.3 “Interfacing Program and Data Memory Spaces”](#).

User access to the program memory space is restricted to the lower half of the address range (000000h to 7FFFFFFh). The exception is the use of `TBLRD/TBLWT` operations, which use `TBLPAG[7]` to permit access to the Configuration bits and customer OTP sections of the configuration memory space.

The memory map for the PIC24FJ256GA705 family of devices is shown in [Figure 4-1](#).

PIC24FJ256GA705 FAMILY

FIGURE 4-1: PROGRAM SPACE MEMORY MAP FOR PIC24FJ256GA705 DEVICES

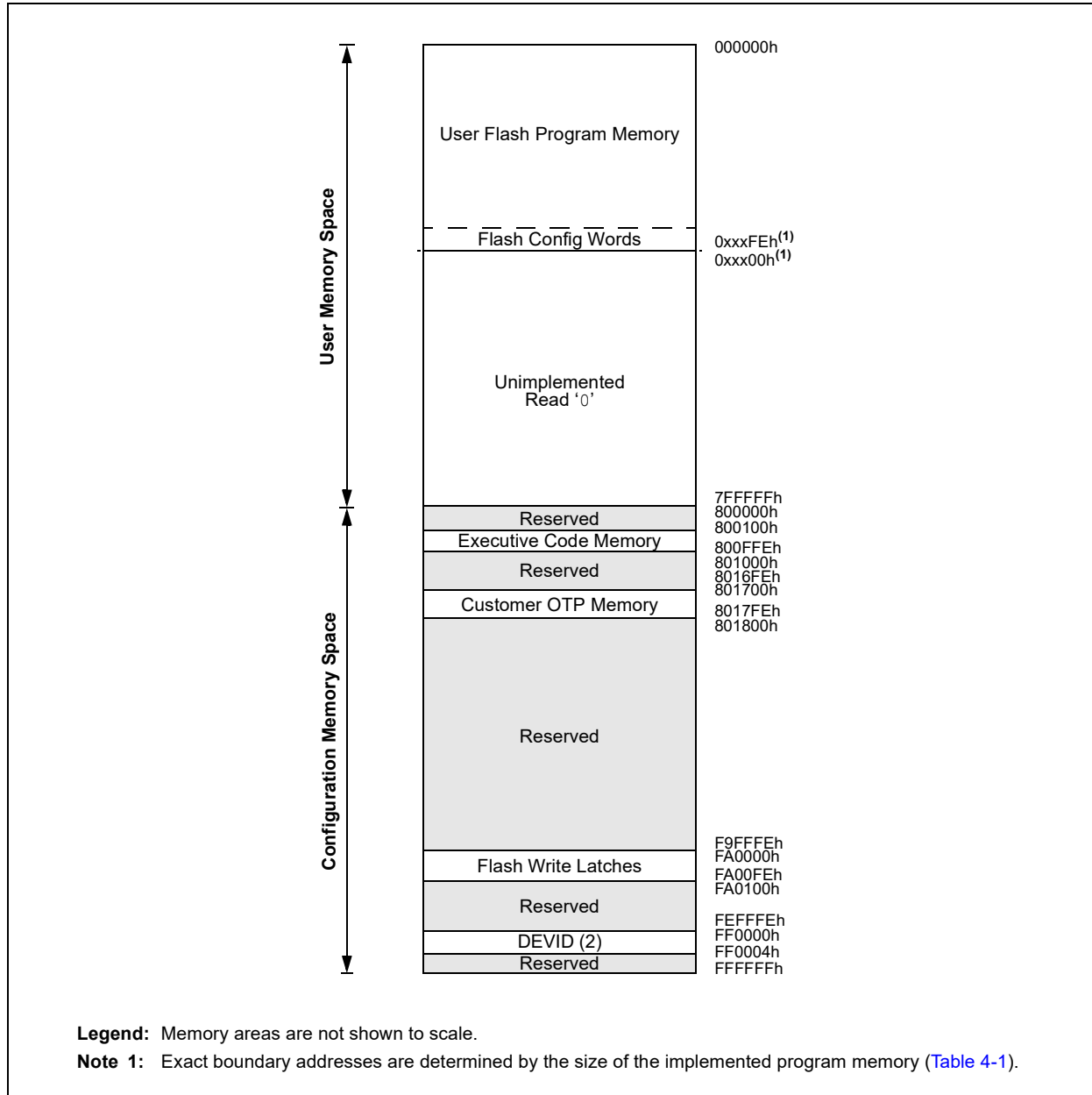

TABLE 4-1: PROGRAM MEMORY SIZES AND BOUNDARIES⁽²⁾

Device	Program Memory Upper Boundary (Instruction Words)	Write Blocks ⁽¹⁾	Erase Blocks ⁽¹⁾
PIC24FJ256GA70X	02AFFEh (88,064 x 24)	688	86
PIC24FJ128GA70X	015FFEh (45,056 x 24)	352	44
PIC24FJ64GA70X	00AFFEh (22,528 x 24)	176	22

Note 1: One Write Block = 128 Instruction Words; One Erase Block (Page) = 1024 Instruction Words.

Note 2: To maintain integer page sizes, the memory sizes are not exactly half of each other.

4.1.1 PROGRAM MEMORY ORGANIZATION

The program memory space is organized in word-addressable blocks. Although it is treated as 24 bits wide, it is more appropriate to think of each address of the program memory as a lower and upper word, with the upper byte of the upper word being unimplemented. The lower word always has an even address, while the upper word has an odd address (Figure 4-2).

Program memory addresses are always word-aligned on the lower word and addresses are incremented or decremented by two during code execution. This arrangement also provides compatibility with data memory space addressing and makes it possible to access data in the program memory space.

4.1.2 HARD MEMORY VECTORS

All PIC24F devices reserve the addresses between 000000h and 000200h for hard-coded program execution vectors. A hardware Reset vector is provided to redirect code execution from the default value of the PC on a device Reset to the actual start of code. A GOTO instruction is programmed by the user at 000000h, with the actual address for the start of code at 000002h.

The PIC24FJ256GA705 family devices can have up to two Interrupt Vector Tables (IVTs). The first is located from addresses, 000004h to 0000FFh. The Alternate

Interrupt Vector Table (AIVT) can be enabled by the AIVTDIS Configuration bit if the Boot Segment (BS) is present and at least two pages in size. If the user has configured a Boot Segment, the AIVT will be located at the address, (BSLIM[12:0] – 1) x 0x800. These vector tables allow each of the many device interrupt sources to be handled by separate Interrupt Service Routines (ISRs).

A more detailed discussion of the Interrupt Vector Tables is provided in Section 8.1 “Interrupt Vector Table”.

4.1.3 CONFIGURATION BITS OVERVIEW

The Configuration bits are stored in the last page location of implemented program memory. These bits can be set or cleared to select various device configurations. There are two types of Configuration bits: system operation bits and code-protect bits. The system operation bits determine the power-on settings for system-level components, such as the oscillator and the Watchdog Timer. The code-protect bits prevent program memory from being read and written.

Table 4-2 lists all of the Configuration registers as well as their Configuration register locations. Refer to Section 29.0 “Special Features” for the full Configuration register description for each specific device.

TABLE 4-2: CONFIGURATION WORD ADDRESSES

Configuration Registers	PIC24FJ256GA70X	PIC24FJ128GA70X	PIC24FJ64GA70X
FSEC	02AF00h	015F00h	00AF00h
FBSLIM	02AF10h	015F10h	00AF10h
FSIGN	02AF14h	015F14h	00AF14h
FOSCSEL	02AF18h	015F18h	00AF18h
FOSC	02AF1Ch	015F1Ch	00AF1Ch
FWDT	02AF20h	015F20h	00AF20h
FPOR	02AF24h	015F24h	00AF24h
FICD	02AF28h	015F28h	00AF28h
FDEVOPT1	02AF2Ch	015F2Ch	00AF2Ch

PIC24FJ256GA705 FAMILY

4.1.4 CODE-PROTECT CONFIGURATION BITS

The device implements intermediate security features defined by the FSEC register. The Boot Segment (BS) is the higher privileged segment and the General Segment (GS) is the lower privileged segment. The total user code memory can be split into BS or GS. The size of the segments is determined by the BSLIM[12:0] bits. The relative location of the segments within user space does not change, such that BS (if present) occupies the memory area just after the Interrupt Vector Table (IVT) and the GS occupies the space just after the BS (or if the Alternate IVT is enabled, just after it).

The Configuration Segment (CS) is a small segment (less than a page, typically just one row) within user Flash address space. It contains all user configuration data that are loaded by the NVM Controller during the Reset sequence.

4.1.5 CUSTOMER OTP MEMORY

PIC24FJ256GA705 family devices provide 256 bytes of One-Time-Programmable (OTP) memory, located at addresses, 801700h through 8017FEh. This memory can be used for persistent storage of application-specific information that will not be erased by reprogramming the device. This includes many types of information, such as (but not limited to):

- Application Checksums
- Code Revision Information
- Product Information
- Serial Numbers
- System Manufacturing Dates
- Manufacturing Lot Numbers

Customer OTP memory may be programmed in any mode, including user RTSP mode, but it cannot be erased. Data are not cleared by a chip erase.

Note: Do not write the OTP memory more than one time. Writing to the OTP memory more than once may result in a permanent ECC Double-Bit Error (ECCDBE) trap.

4.2 Data Memory Space

Note: This data sheet summarizes the features of this group of PIC24F devices. It is not intended to be a comprehensive reference source. For more information, refer to **“Data Memory with Extended Data Space (EDS)”** (www.microchip.com/DS39733) in the *“dsPIC33/PIC24 Family Reference Manual”*. The information in this data sheet supersedes the information in the FRM.

The PIC24F core has a 16-bit wide data memory space, addressable as a single linear range. The Data Space is accessed using two Address Generation Units (AGUs), one each for read and write operations. The Data Space memory map is shown in [Figure 4-2](#).

The 16-bit wide data addresses in the data memory space point to bytes within the Data Space (DS). This gives a DS address range of 16 Kbytes or 8K words. The lower half (0000h to 7FFFh) is used for implemented (on-chip) memory addresses.

The upper half of data memory address space (8000h to FFFFh) is used as a window into the Extended Data Space (EDS). This allows the microcontroller to directly access a greater range of data beyond the standard 16-bit address range. EDS is discussed in detail in [Section 4.2.5 “Extended Data Space \(EDS\)”](#).

4.2.1 DATA SPACE WIDTH

The data memory space is organized in byte-addressable, 16-bit wide blocks. Data are aligned in data memory and registers as 16-bit words, but all Data Space EAs resolve to bytes. The Least Significant Bytes (LSBs) of each word have even addresses, while the Most Significant Bytes (MSBs) have odd addresses.

FIGURE 4-2: DATA SPACE MEMORY MAP FOR PIC24FJ256GA705 DEVICES

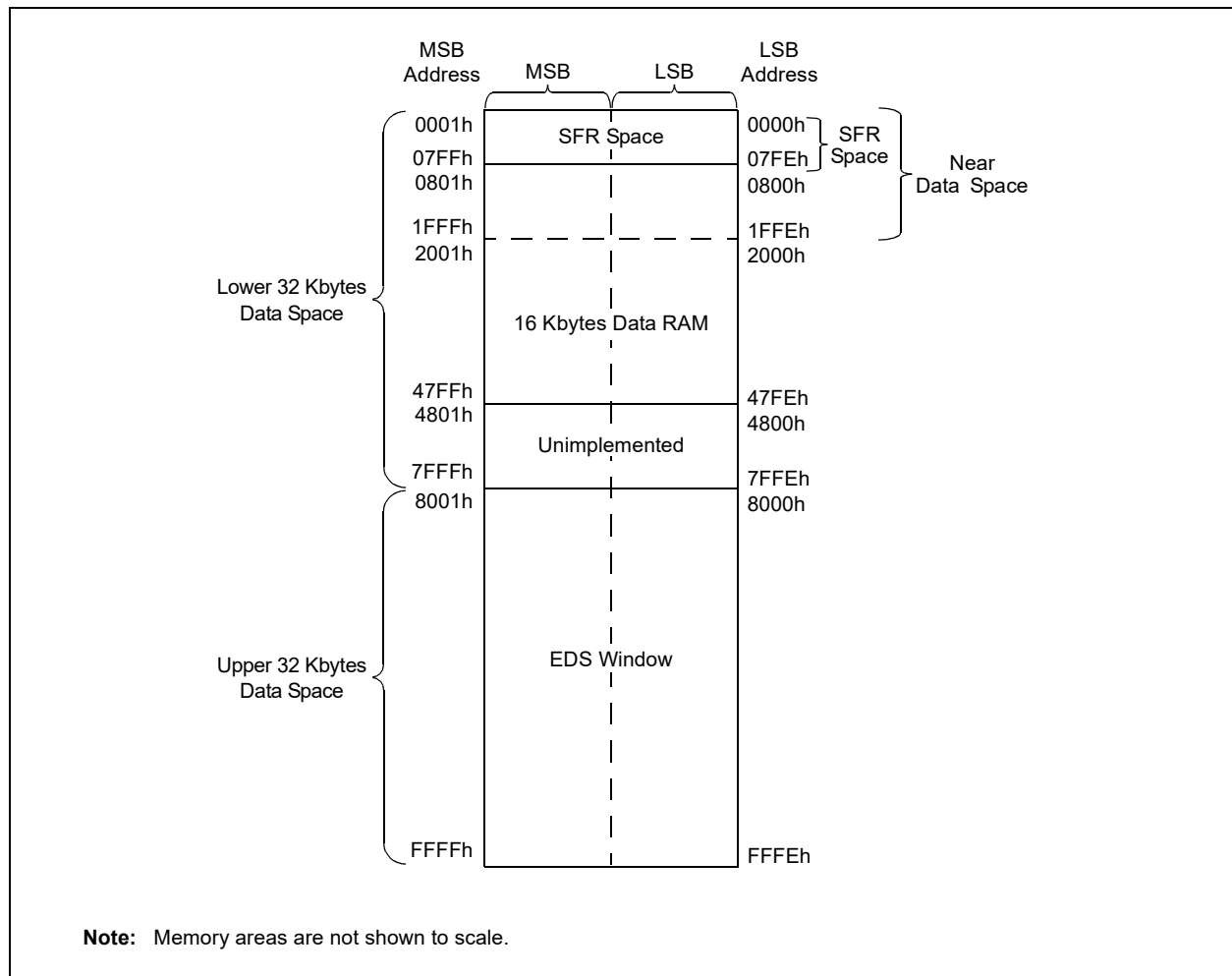

PIC24FJ256GA705 FAMILY

4.2.2 DATA MEMORY ORGANIZATION AND ALIGNMENT

To maintain backward compatibility with PIC® MCUs and improve Data Space memory usage efficiency, the PIC24F instruction set supports both word and byte operations. As a consequence of byte accessibility, all EA calculations are internally scaled to step through word-aligned memory. For example, the core recognizes that Post-Modified Register Indirect Addressing mode, [Ws++], will result in a value of Ws + 1 for byte operations and Ws + 2 for word operations.

Data byte reads will read the complete word, which contains the byte, using the LSB of any EA to determine which byte to select. The selected byte is placed onto the LSB of the data path. That is, data memory and registers are organized as two parallel, byte-wide entities with shared (word) address decode, but separate write lines. Data byte writes only write to the corresponding side of the array or register which matches the byte address.

All word accesses must be aligned to an even address. Misaligned word data fetches are not supported, so care must be taken when mixing byte and word operations or translating from 8-bit MCU code. If a misaligned read or write is attempted, an address error trap will be generated. If the error occurred on a read, the instruction underway is completed; if it occurred on a write, the instruction will be executed but the write will not occur. In either case, a trap is then executed, allowing the system and/or user to examine the machine state prior to execution of the address Fault.

All byte loads into any W register are loaded into the LSB. The Most Significant Byte (MSB) is not modified.

A Sign-Extend (SE) instruction is provided to allow users to translate 8-bit signed data to 16-bit signed values. Alternatively, for 16-bit unsigned data, users can clear the MSB of any W register by executing a Zero-Extend (ZE) instruction on the appropriate address.

Although most instructions are capable of operating on word or byte data sizes, it should be noted that some instructions operate only on words.

4.2.3 NEAR DATA SPACE

The 8-Kbyte area between 0000h and 1FFFh is referred to as the Near Data Space. Locations in this space are directly addressable via a 13-bit absolute address field within all memory direct instructions. The remainder of the Data Space is addressable indirectly. Additionally, the whole Data Space is addressable using MOV instructions, which support Memory Direct Addressing with a 16-bit address field.

4.2.4 SPECIAL FUNCTION REGISTER (SFR) SPACE

The first 2 Kbytes of the Near Data Space, from 0000h to 07FFh, are primarily occupied with Special Function Registers (SFRs). These are used by the PIC24F core and peripheral modules for controlling the operation of the device.

SFRs are distributed among the modules that they control and are generally grouped together by module. Much of the SFR space contains unused addresses; these are read as '0'. A diagram of the SFR space, showing where the SFRs are actually implemented, is shown in Table 4-3. Each implemented area indicates a 32-byte region where at least one address is implemented as an SFR. A complete list of implemented SFRs, including their addresses, is shown in Table 4-4 through 4-11.

TABLE 4-3: IMPLEMENTED REGIONS OF SFR DATA SPACE⁽²⁾

SFR Space Address																
	xx00	xx10	xx20	xx30	xx40	xx50	xx60	xx70	xx80	xx90	xxA0	xxB0	xxC0	xxD0	xxE0	xxF0
000h	Core															
100h	OSC	Reset ⁽¹⁾	EPMP			CRC	REFO	PMD	Timers		—	CTMU	RTCC			
200h	Capture		Compare			MCCP						Comp	ANCFG			
300h	MCCP			—	—	—	—	—	UART			—	—	—	SPI	
400h	SPI				—	CLC		—	—	I ² C			DMA			
500h	DMA	—	—	—	—	—	—	—	—	—	—	—	—	—	—	—
600h	—	—	—	—	—	I/O									—	
700h	—	A/D				NVM	—	—	PPS							

Legend: — = No implemented SFRs in this block

Note 1: Includes HLVD control.

2: Regions shown are approximate. Refer to Table 4-4 through Table 4-11 for exact addresses.

PIC24FJ256GA705 FAMILY

TABLE 4-4: SFR MAP: 0000h BLOCK

File Name	Address	All Resets	File Name	Address	All Resets
CPU CORE			INTERRUPT CONTROLLER (CONTINUED)		
WREG0	0000	0000	IEC1	009A	0000
WREG1	0002	0000	IEC2	009C	0000
WREG2	0004	0000	IEC3	009E	0000
WREG3	0006	0000	IEC4	00A0	0000
WREG4	0008	0000	IEC5	00A2	0000
WREG5	000A	0000	IEC6	00A4	0000
WREG6	000C	0000	IEC7	00A6	0000
WREG7	000E	0000	IPC0	00A8	4444
WREG8	0010	0000	IPC1	00AA	4444
WREG9	0012	0000	IPC2	00AC	4444
WREG10	0014	0000	IPC3	00AE	4444
WREG11	0016	0000	IPC4	00B0	4444
WREG12	0018	0000	IPC5	00B2	4404
WREG13	001A	0000	IPC6	00B4	4444
WREG14	001C	0000	IPC7	00B6	4444
WREG15	001E	0800	IPC8	00B8	0044
SPLIM	0020	xxxx	IPC9	00BA	4444
PCL	002E	0000	IPC10	00BC	4444
PCH	0030	0000	IPC11	00BE	4444
DSRPAG	0032	0000	IPC12	00C0	4444
DSWPAG	0034	0000	IPC13	00C2	0440
RCOUNT	0036	xxxx	IPC14	00C4	4400
SR	0042	0000	IPC15	00C6	4444
CORCON	0044	0004	IPC16	00C8	4444
DISICNT	0052	xxxx	IPC17	00CA	4444
TBLPAG	0054	0000	IPC18	00CC	0044
INTERRUPT CONTROLLER			IPC19	00CE	0040
INTCON1	0080	0000	IPC20	00D0	4440
INTCON2	0082	8000	IPC21	00D2	4444
INTCON4	0086	0000	IPC22	00D4	4444
IFS0	0088	0000	IPC23	00D6	4400
IFS1	008A	0000	IPC24	00D8	4444
IFS2	008C	0000	IPC25	00DA	0440
IFS3	008E	0000	IPC26	00DC	0400
IFS4	0090	0000	IPC27	00DE	4440
IFS5	0092	0000	IPC28	00E0	4444
IFS6	0094	0000	IPC29	00E2	0044
IFS7	0096	0000	INTTREG	00E4	0000
IEC0	0098	0000			

Legend: x = undefined. Reset values are shown in hexadecimal.

PIC24FJ256GA705 FAMILY

TABLE 4-5: SFR MAP: 0100h BLOCK

File Name	Address	All Resets	File Name	Address	All Resets
OSCILLATOR			PMD (CONTINUED)		
OSCCON	0100	xxx0	PMD3	017C	0000
CLKDIV	0102	30x0	PMD4	017E	0000
OSCTUN	0108	0000	PMD5	0180	0000
OSCDIV	010C	0001	PMD6	0182	0000
OSCFDIV	010E	0000	PMD7	0184	0000
RESET			PMD8	0186	0000
RCON	0110	0003	TIMER		
HLVD			TMR1	0190	0000
HLVDCON	0114	0000	PR1	0192	FFFF
PMP			T1CON	0194	0000
PMCON1	0128	0000	TMR2	0196	0000
PMCON2	012A	0000	TMR3HLD	0198	0000
PMCON3	012C	0000	TMR3	019A	0000
PMCON4	012E	0000	PR2	019C	FFFF
PMCS1CF	0130	0000	PR3	019E	FFFF
PMCS1BS	0132	0000	T2CON	01A0	0x00
PMCS1MD	0134	0000	T3CON	01A2	0x00
PMCS2CF	0136	0000	CTMU		
PMCS2BS	0138	0000	CTMUCON1L	01C0	0000
PMCS2MD	013A	0000	CTMUCON1H	01C2	0000
PMDOUT1	013C	xxxx	CTMUCON2L	01C4	0000
PMDOUT2	013E	xxxx	REAL-TIME CLOCK AND CALENDAR (RTCC)		
PMDIN1	0140	xxxx	RTCCON1L	01CC	xxxx
PMDIN2	0142	xxxx	RTCCON1H	01CE	xxxx
PMSTAT	0144	008F	RTCCON2L	01D0	xxxx
CRC			RTCCON2H	01D2	xxxx
CRCCON1	0158	00x0	RTCCON3L	01D4	xxxx
CRCCON2	015A	0000	RTCSTATL	01D8	00xx
CRCXORL	015C	0000	TIMEL	01DC	xx00
CRCXORH	015E	0000	TIMEH	01DE	xxxx
CRCDATL	0160	xxxx	DATEL	01E0	xx0x
CRCDATH	0162	xxxx	DATEH	01E2	xxxx
CRCWDATL	0164	xxxx	ALMTIMEL	01E4	xx00
CRCWDATH	0166	xxxx	ALMTIMEH	01E6	xxxx
REFO			ALMDATEL	01E8	xx0x
REFOCONL	0168	0000	ALMDATEH	01EA	xxxx
REFOCONH	016A	0000	TSATIMEL	01EC	xx00
PMD			TSATIMEH	01EE	xxxx
PMD1	0178	0000	TSADATEL	01F0	xx0x
PMD2	017A	0000	TSADATEH	01F2	xxxx

Legend: x = undefined. Reset values are shown in hexadecimal.

PIC24FJ256GA705 FAMILY

TABLE 4-6: SFR MAP: 0200h BLOCK

File Name	Address	All Resets	File Name	Address	All Resets
INPUT CAPTURE			MULTIPLE OUTPUT CAPTURE/COMPARE/PWM (CONTINUED)		
IC1CON1	0200	0000	CCP1RAH	0286	0000
IC1CON2	0202	000D	CCP1RBL	0288	0000
IC1BUF	0204	0000	CCP1RBH	028A	0000
IC1TMR	0206	0000	CCP1BUFL	028C	0000
IC2CON1	0208	0000	CCP1BUFH	028E	0000
IC2CON2	020A	000D	CCP2CON1L	0290	0000
IC2BUF	020C	0000	CCP2CON1H	0292	0000
IC2TMR	020E	0000	CCP2CON2L	0294	0000
IC3CON1	0210	0000	CCP2CON2H	0296	0100
IC3CON2	0212	000D	CCP2CON3L	0298	0000
IC3BUF	0214	0000	CCP2CON3H	029A	0000
IC3TMR	0216	0000	CCP2STATL	029C	00x0
OUTPUT COMPARE			CCP2TMRL	02A0	0000
OC1CON1	0230	0000	CCP2TMRH	02A2	0000
OC1CON2	0232	000C	CCP2PRL	02A4	FFFF
OC1RS	0234	xxxx	CCP2PRH	02A6	FFFF
OC1R	0236	xxxx	CCP2RAL	02A8	0000
OC1TMR	0238	xxxx	CCP2RAH	02AA	0000
OC2CON1	023A	0000	CCP2RBL	02AC	0000
OC2CON2	023C	000C	CCP2RBH	02AE	0000
OC2RS	023E	xxxx	CCP2BUFL	02B0	0000
OC2R	0240	xxxx	CCP2BUFH	02B2	0000
OC2TMR	0242	xxxx	CCP3CON1L	02B4	0000
OC3CON1	0244	0000	CCP3CON1H	02B6	0000
OC3CON2	0246	000C	CCP3CON2L	02B8	0000
OC3RS	0248	xxxx	CCP3CON2H	02BA	0100
OC3R	024A	xxxx	CCP3CON3L	02BC	0000
OC3TMR	024C	xxxx	CCP3CON3H	02BE	0000
MULTIPLE OUTPUT CAPTURE/COMPARE/PWM			CCP3STATL	02C0	00x0
CCP1CON1L	026C	0000	CCP3TMRL	02C4	0000
CCP1CON1H	026E	0000	CCP3TMRH	02C6	0000
CCP1CON2L	0270	0000	CCP3PRL	02C8	FFFF
CCP1CON2H	0272	0100	CCP3PRH	02CA	FFFF
CCP1CON3L	0274	0000	CCP3RAL	02CC	0000
CCP1CON3H	0276	0000	CCP3RAH	02CE	0000
CCP1STATL	0278	00x0	CCP3RBL	02D0	0000
CCP1TMRL	027C	0000	CCP3RBH	02D2	0000
CCP1TMRH	027E	0000	CCP3BUFL	02D4	0000
CCP1PRL	0280	FFFF	CCP3BUFH	02D6	0000
CCP1PRH	0282	FFFF			
CCP1RAL	0284	0000			

Legend: x = undefined. Reset values are shown in hexadecimal.

PIC24FJ256GA705 FAMILY

TABLE 4-6: SFR MAP: 0200h BLOCK (CONTINUED)

File Name	Address	All Resets	File Name	Address	All Resets
COMPARATORS			COMPARATORS (CONTINUED)		
CMSTAT	02E6	0000	CM3CON	02EE	0000
CVRCON	02E8	00xx	ANALOG CONFIGURATION		
CM1CON	02EA	0000	ANCFG	02F4	0000
CM2CON	02EC	0000			

Legend: x = undefined. Reset values are shown in hexadecimal.

TABLE 4-7: SFR MAP: 0300h BLOCK

File Name	Address	All Resets	File Name	Address	All Resets
MULTIPLE OUTPUT CAPTURE/COMPARE/PWM			UART		
CCP4CON1L	0300	0000	U1MODE	0398	0000
CCP4CON1H	0302	0000	U1STA	039A	0110
CCP4CON2L	0304	0000	U1TXREG	039C	x0xx
CCP4CON2H	0306	0100	U1RXREG	039E	0000
CCP4CON3L	0308	0000	U1BRG	03A0	0000
CCP4CON3H	030A	0000	U1ADMD	03A2	0000
CCP4STATL	030C	00x0	U2MODE	03AE	0000
CCP4TMRL	0310	0000	U2STA	03B0	0110
CCP4TMRH	0312	0000	U2TXREG	03B2	xxxx
CCP4PRL	0314	FFFF	U2RXREG	03B4	0000
CCP4PRH	0316	FFFF	U2BRG	03B6	0000
CCP4RAL	0318	0000	U2ADMD	03B8	0000
CCP4RAH	031A	0000	SPI		
CCP4RBL	031C	0000	SPI1CON1L	03F4	0x00
CCP4RBH	031E	0000	SPI1CON1H	03F6	0000
CCP4BUFL	0320	0000	SPI1CON2L	03F8	0000
CCP4BUFH	0322	0000	SPI1STATL	03FC	0028
			SPI1CON2H	03F8	0000
			SPI1STATH	03FE	0000

Legend: x = undefined. Reset values are shown in hexadecimal.

PIC24FJ256GA705 FAMILY

TABLE 4-8: SFR MAP: 0400h BLOCK

File Name	Address	All Resets	File Name	Address	All Resets
SPI (CONTINUED)			I²C (CONTINUED)		
SPI1BUFL	0400	0000	I2C1BRG	0498	0000
SPI1BUFH	0402	0000	I2C1CONL	049A	1000
SPI1BRGL	0404	xxxx	I2C1CONH	049C	0000
SPI1IMSKL	0408	0000	I2C1STAT	049E	0000
SPI1IMSKH	040A	0000	I2C1ADD	04A0	0000
SPI1URDTL	040C	0000	I2C1MSK	04A2	0000
SPI1URDTH	040E	0000	I2C2RCV	04A4	0000
SPI2CON1L	0410	0x00	I2C2TRN	04A6	00FF
SPI2CON1H	0412	0000	I2C2BRG	04A8	0000
SPI2CON2L	0414	0000	I2C2CONL	04AA	1000
SPI2STATL	0418	0028	I2C2CONH	04AC	0000
SPI2STATH	041A	0000	I2C2STAT	04AE	0000
SPI2BUFL	041C	0000	I2C2ADD	04B0	0000
SPI2BUFH	041E	0000	I2C2MSK	04B2	0000
SPI2BRGL	0420	xxxx	DMA		
SPI2IMSKL	0424	0000	DMACON	04C4	0000
SPI2IMSKH	0426	0000	DMABUF	04C6	0000
SPI2URDTL	0428	0000	DMAL	04C8	0000
SPI2URDTH	042A	0000	DMAH	04CA	0000
SPI3CON1L	042C	0x00	DMACH0	04CC	0000
SPI3CON1H	042E	0000	DMAINT0	04CE	0000
SPI3CON2L	0430	0000	DMASRC0	04D0	0000
SPI3STATL	0434	0028	DMADST0	04D2	0000
SPI3STATH	0436	0000	DMACNT0	04D4	0001
SPI3BUFL	0438	0000	DMACH1	04D6	0000
SPI3BUFH	043A	0000	DMAINT1	04D8	0000
SPI3BRGL	043C	xxxx	DMASRC1	04DA	0000
SPI3IMSKL	0440	0000	DMADST1	04DC	0000
SPI3IMSKH	0442	0000	DMACNT1	04DE	0001
SPI3URDTL	0444	0000	DMACH2	04E0	0000
SPI3URDTH	0446	0000	DMAINT2	04E2	0000
CONFIGURABLE LOGIC CELL (CLC)			DMASRC2	04E4	0000
CLC1CONL	0464	0000	DMADST2	04E6	0000
CLC1CONH	0466	0000	DMACNT2	04E8	0001
CLC1SEL	0468	0000	DMACH3	04EA	0000
CLC1GLSL	046C	0000	DMAINT3	04EC	0000
CLC1GLSH	046E	0000	DMASRC3	04EE	0000
CLC2CONL	0470	0000	DMADST3	04F0	0000
CLC2CONH	0472	0000	DMACNT3	04F2	0001
CLC2SEL	0474	0000	DMACH4	04F4	0000
CLC2GLSL	0478	0000	DMAINT4	04F6	0000
CLC2GLSH	047A	0000	DMASRC4	04F8	0000
I²C			DMADST4	04FA	0000
I2C1RCV	0494	0000	DMACNT4	04FC	0001
I2C1TRN	0496	00FF	DMACH5	04FE	0000

Legend: x = undefined. Reset values are shown in hexadecimal.

PIC24FJ256GA705 FAMILY

TABLE 4-9: SFR MAP: 0500h BLOCK

File Name	Address	All Resets	File Name	Address	All Resets
DMA (CONTINUED)			DMA (CONTINUED)		
DMAINT5	0500	0000	DMADST5	0504	0000
DMASRC5	0502	0000	DMACNT5	0506	0001

Legend: x = undefined. Reset values are shown in hexadecimal.

TABLE 4-10: SFR MAP: 0600h BLOCK

File Name	Address	All Resets	File Name	Address	All Resets
I/O			PORTB (CONTINUED)		
PADCON	065E	0000	ANSB	067E	FFFF
IOCSTAT	0660	0000	IOCPB	0680	0000
PORTA			IOCNB	0682	0000
TRISA	0662	FFFF	IOCFB	0684	0000
PORTA	0664	0000	IOCPUB	0686	0000
LATA	0666	0000	IOCPDB	0688	0000
ODCA	0668	0000	PORTC		
ANSA	066A	FFFF	TRISC	068A	FFFF
IOCPA	066C	0000	PORTC	068C	0000
IOCNA	066E	0000	LATC	068E	0000
IOCFA	0670	0000	ODCC	0690	0000
IOCPUA	0672	0000	ANSC	0692	FFFF
IOCPDA	0674	0000	IOCPD	0694	0000
PORTB			IOCNC	0696	0000
TRISB	0676	FFFF	IOCFD	0698	0000
PORTB	0678	0000	IOCPUC	069A	0000
LATB	067A	0000	IOCPDC	069C	0000
ODCB	067C	0000			

Legend: x = undefined. Reset values are shown in hexadecimal.

PIC24FJ256GA705 FAMILY

TABLE 4-11: SFR MAP: 0700h BLOCK

File Name	Address	All Resets	File Name	Address	All Resets
A/D			PERIPHERAL PIN SELECT		
ADC1BUF0	0712	xxxx	RPINR0	0790	3F3F
ADC1BUF1	0714	xxxx	RPINR1	0792	3F3F
ADC1BUF2	0716	xxxx	RPINR2	0794	3F3F
ADC1BUF3	0718	xxxx	RPINR3	0796	3F3F
ADC1BUF4	071A	xxxx	RPINR5	079A	3F3F
ADC1BUF5	071C	xxxx	RPINR6	079C	3F3F
ADC1BUF6	071E	xxxx	RPINR7	079E	3F3F
ADC1BUF7	0720	xxxx	RPINR8	07A0	003F
ADC1BUF8	0722	xxxx	RPINR11	07A6	3F3F
ADC1BUF9	0724	xxxx	RPINR12	07A8	3F3F
ADC1BUF10	0726	xxxx	RPINR18	07B4	3F3F
ADC1BUF11	0728	xxxx	RPINR19	07B6	3F3F
ADC1BUF12	072A	xxxx	RPINR20	07B8	3F3F
ADC1BUF13	072C	xxxx	RPINR21	07BA	3F3F
ADC1BUF14	072E	xxxx	RPINR22	07BC	3F3F
ADC1BUF15	0730	xxxx	RPINR23	07BE	3F3F
AD1CON1	0746	xxxx	RPINR25	07C2	3F3F
AD1CON2	0748	xxxx	RPINR28	07C8	3F3F
AD1CON3	074A	xxxx	RPINR29	07CA	003F
AD1CHS	074C	xxxx	RPOR0	07D4	0000
AD1CSSH	074E	xxxx	RPOR1	07D6	0000
AD1CSSL	0750	xxxx	RPOR2	07D8	0000
AD1CON4	0752	xxxx	RPOR3	07DA	0000
AD1CON5	0754	xxxx	RPOR4	07DC	0000
AD1CHITL	0758	xxxx	RPOR5	07DE	0000
AD1CTMENH	075A	0000	RPOR6	07E0	0000
AD1CTMENL	075C	0000	RPOR7	07E2	0000
AD1RESDMA	075E	0000	RPOR8	07E4	0000
NVM			RPOR9	07E6	0000
NVMCON	0760	0000	RPOR10	07E8	0000
NVMADR	0762	xxxx	RPOR11	07EA	0000
NVMADRU	0764	00xx	RPOR12	07EC	0000
NVMKEY	0766	0000	RPOR13	07EE	0000
			RPOR14	07F0	0000

Legend: x = undefined. Reset values are shown in hexadecimal.

PIC24FJ256GA705 FAMILY

4.2.5 EXTENDED DATA SPACE (EDS)

The Extended Data Space (EDS) allows PIC24F devices to address a much larger range of data than would otherwise be possible with a 16-bit address range. EDS includes any additional internal data memory not directly accessible by the lower 32-Kbyte data address space and any external memory through EPMP.

In addition, EDS also allows read access to the program memory space. This feature is called Program Space Visibility (PSV) and is discussed in detail in [Section 4.3.3 “Reading Data from Program Memory Using EDS”](#).

[Figure 4-3](#) displays the entire EDS space. The EDS is organized as pages, called EDS pages, with one page equal to the size of the EDS window (32 Kbytes). A particular EDS page is selected through the Data Space Read Page register (DSRPAG) or the Data Space Write Page register (DSWPAG). For PSV, only the DSRPAG register is used. The combination of the DSRPAG register value and the 16-bit wide data address forms a 24-bit Effective Address (EA).

The data addressing range of the PIC24FJ256GA705 family devices depends on the version of the Enhanced Parallel Master Port implemented on a particular device; this is, in turn, a function of device pin count. [Table 4-12](#) lists the total memory accessible by each of the devices in this family. For more details on accessing external memory using EPMP, refer to “[Enhanced Parallel Master Port \(EPMP\)](#)” (www.microchip.com/DS39730) in the “*dsPIC33/PIC24 Family Reference Manual*”.

TABLE 4-12: TOTAL ACCESSIBLE DATA MEMORY

Family	Internal RAM	External RAM Access Using EPMP
PIC24FJXXXGA70X	16K	1K

Note: Accessing Page 0 in the EDS window will generate an address error trap as Page 0 is the base data memory (data locations, 0800h to 7FFFh, in the lower Data Space).

FIGURE 4-3: EXTENDED DATA SPACE

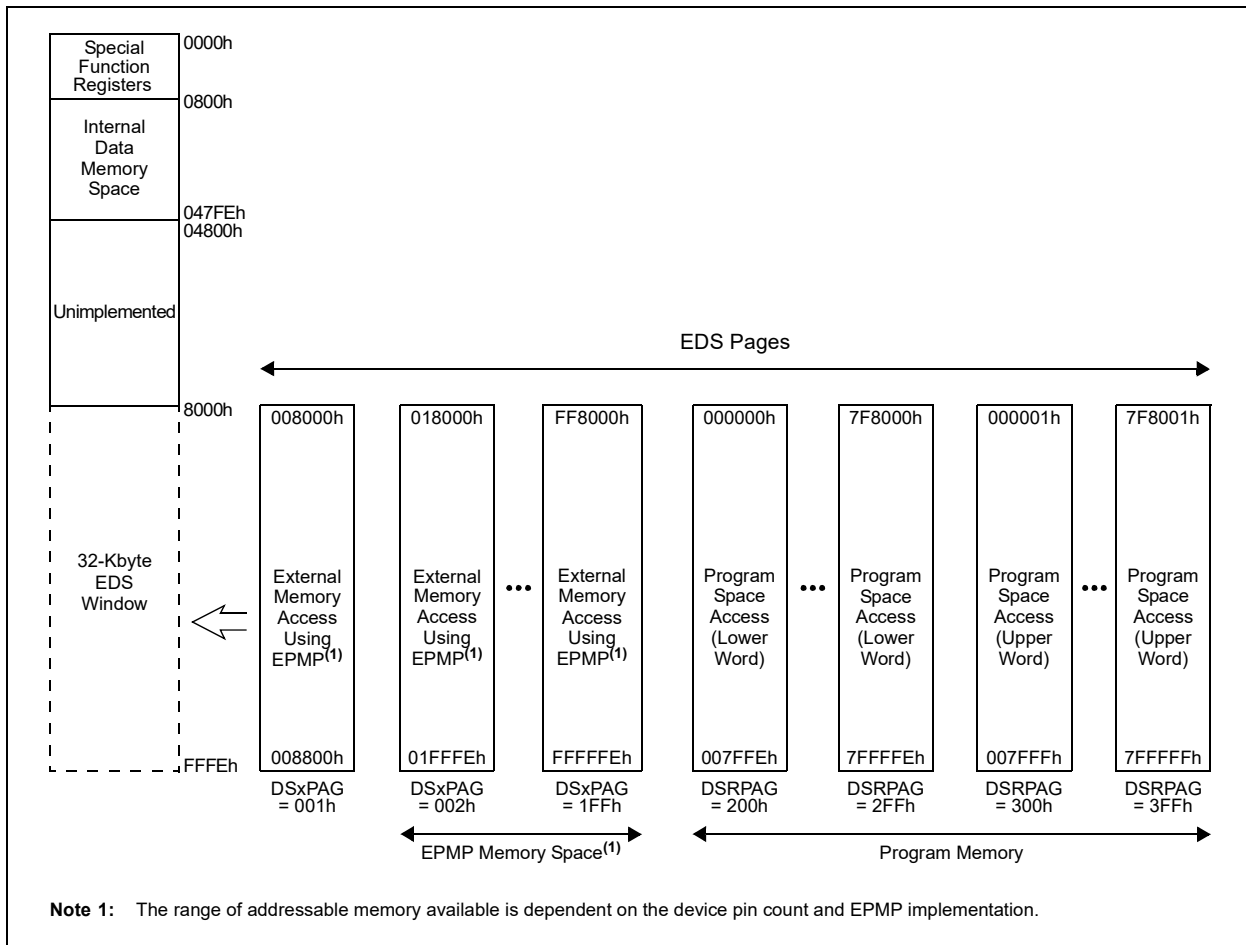

4.2.5.1 Data Read from EDS

In order to read the data from the EDS space, first, an Address Pointer is set up by loading the required EDS page number into the DSRPAG register and assigning the offset address to one of the W registers. Once the above assignment is done, the EDS window is enabled by setting bit 15 of the Working register which is assigned with the offset address; then, the contents of the pointed EDS location can be read.

Figure 4-4 illustrates how the EDS space address is generated for read operations.

When the Most Significant bit (MSb) of EA is '1' and DSRPAG[9] = 0, the lower nine bits of DSRPAG are concatenated to the lower 15 bits of EA to form a 24-bit EDS space address for read operations.

Example 4-1 shows how to read a byte, word and double word from EDS.

Note: All read operations from EDS space have an overhead of one instruction cycle. Therefore, a minimum of two instruction cycles are required to complete an EDS read. EDS reads under the REPEAT instruction; the first two accesses take three cycles and the subsequent accesses take one cycle.

FIGURE 4-4: EDS ADDRESS GENERATION FOR READ OPERATIONS

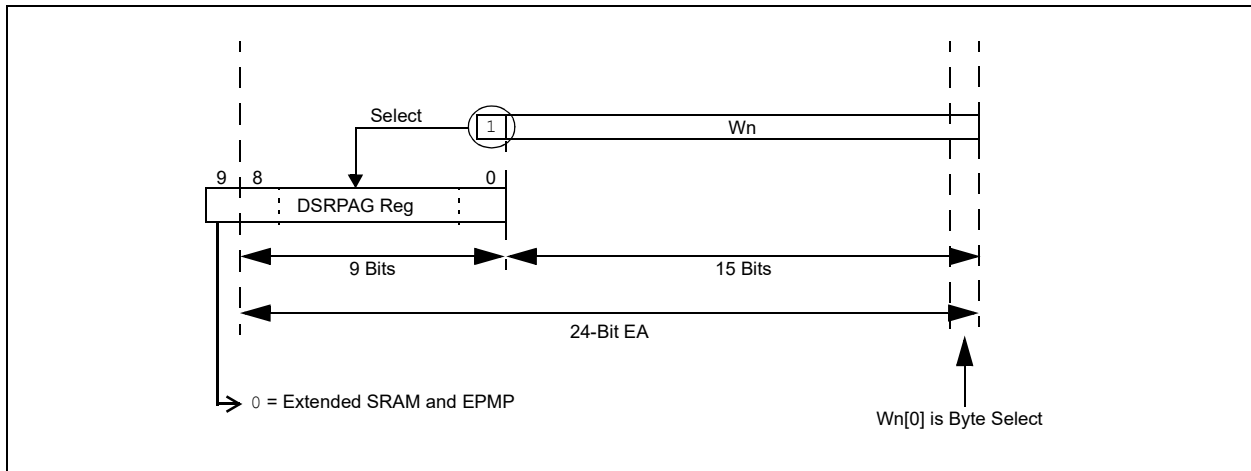

EXAMPLE 4-1: EDS READ CODE IN ASSEMBLY

```

; Set the EDS page from where the data to be read
mov    #0x0002, w0
mov    w0, DSRPAG    ;page 2 is selected for read
mov    #0x0800, w1    ;select the location (0x800) to be read
bset   w1, #15       ;set the MSB of the base address, enable EDS mode

;Read a byte from the selected location
mov.b  [w1++], w2    ;read Low byte
mov.b  [w1++], w3    ;read High byte

;Read a word from the selected location
mov    [w1], w2      ;

;Read Double - word from the selected location
mov.d  [w1], w2      ;two word read, stored in w2 and w3
    
```

PIC24FJ256GA705 FAMILY

4.2.5.2 Data Write into EDS

In order to write data to EDS, such as in EDS reads, an Address Pointer is set up by loading the required EDS page number into the DSWPAG register, and assigning the offset address to one of the W registers. Once the above assignment is done, then the EDS window is enabled by setting bit 15 of the Working register, assigned with the offset address, and the accessed location can be written.

Figure 4-5 illustrates how the EDS address is generated for write operations.

When the MSBs of EA are '1', the lower nine bits of DSWPAG are concatenated to the lower 15 bits of EA to form a 24-bit EDS address for write operations.

Example 4-2 shows how to write a byte, word and double word to EDS.

The Data Space Page registers (DSRPAG/DSWPAG) do not update automatically while crossing a page boundary, when the rollover happens, from 0xFFFF to

0x8000. While developing code in assembly, care must be taken to update the Data Space Page registers when an Address Pointer crosses the page boundary. The 'C' compiler keeps track of the addressing, and increments or decrements the Page registers accordingly, while accessing contiguous data memory locations.

Note 1: All write operations to EDS are executed in a single cycle.

2: Use of Read-Modify-Write operation on any EDS location under a REPEAT instruction is not supported. For example: BCLR, BSW, BTG, RLC f, RLNC f, RRC f, RRNC f, ADD f, SUB f, SUBR f, AND f, IOR f, XOR f, ASR f, ASL f.

3: Use the DSRPAG register while performing Read-Modify-Write operations.

FIGURE 4-5: EDS ADDRESS GENERATION FOR WRITE OPERATIONS

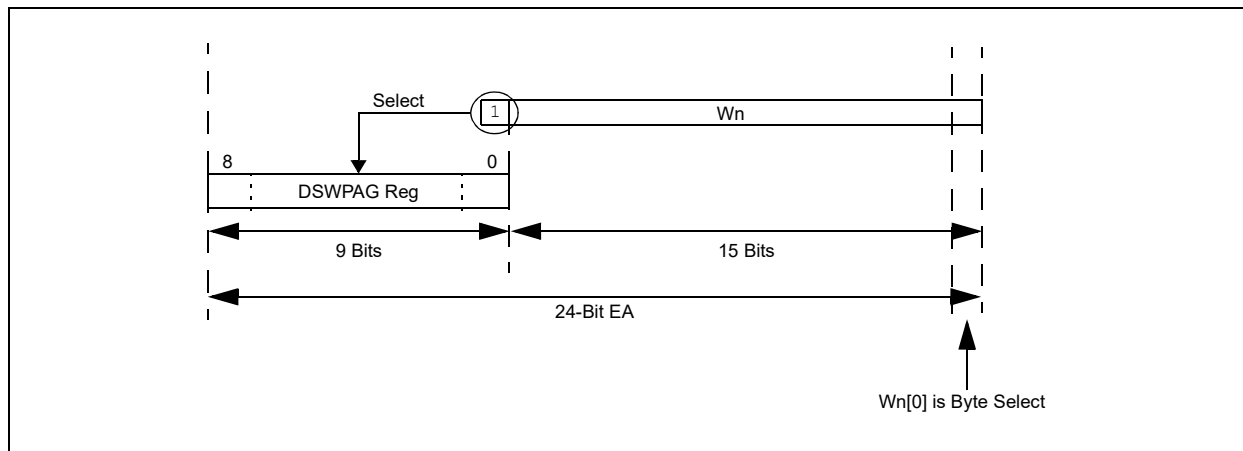

EXAMPLE 4-2: EDS WRITE CODE IN ASSEMBLY

```

; Set the EDS page where the data to be written
mov    #0x0002, w0
mov    w0, DSWPAG    ;page 2 is selected for write
mov    #0x0800, w1    ;select the location (0x800) to be written
bset   w1, #15       ;set the MSB of the base address, enable EDS mode

;Write a byte to the selected location
mov    #0x00A5, w2
mov    #0x003C, w3
mov.b  w2, [w1++]    ;write Low byte
mov.b  w3, [w1++]    ;write High byte

;Write a word to the selected location
mov    #0x1234, w2    ;
mov    w2, [w1]      ;

;Write a Double - word to the selected location
mov    #0x1122, w2
mov    #0x4455, w3
mov.d  w2, [w1]      ;2 EDS writes
    
```

TABLE 4-13: EDS MEMORY ADDRESS WITH DIFFERENT PAGES AND ADDRESSES

DSRPAG (Data Space Read Register)	DSWPAG (Data Space Write Register)	Source/Destination Address while Indirect Addressing	24-Bit EA Pointing to EDS	Comment
x ⁽¹⁾	x ⁽¹⁾	0000h to 1FFFh	000000h to 001FFFh	Near Data Space ⁽²⁾
		2000h to 7FFFh	002000h to 007FFFh	
001h	001h	8000h to FFFFh	008000h to 00FFFEh	EPMP Memory Space
002h	002h		010000h to 017FFEh	
003h	003h		018000h to 0187FEh	
•	•		•	
1FFh	1FFh		FF8000h to FFFFEEh	
000h	000h		Invalid Address	Address Error Trap ⁽³⁾

- Note 1:** If the source/destination address is below 8000h, the DSRPAG and DSWPAG registers are not considered.
Note 2: This Data Space can also be accessed by Direct Addressing.
Note 3: When the source/destination address is above 8000h and DSRPAG/DSWPAG are '0', an address error trap will occur.

4.2.6 SOFTWARE STACK

Apart from its use as a Working register, the W15 register in PIC24F devices is also used as a Software Stack Pointer (SSP). The pointer always points to the first available free word and grows from lower to higher addresses. It pre-decrements for stack pops and post-increments for stack pushes, as shown in Figure 4-6. Note that for a PC push during any CALL instruction, the MSB of the PC is zero-extended before the push, ensuring that the MSB is always clear.

Note: A PC push during exception processing will concatenate the SRL register to the MSB of the PC prior to the push.

The Stack Pointer Limit Value register (SPLIM), associated with the Stack Pointer, sets an upper address boundary for the stack. SPLIM is uninitialized at Reset. As is the case for the Stack Pointer, SPLIM[0] is forced to '0' as all stack operations must be word-aligned. Whenever an EA is generated using W15 as a source or destination pointer, the resulting address is compared with the value in SPLIM. If the contents of the Stack Pointer (W15) and the SPLIM register are equal, and a push operation is performed, a stack error trap will not occur. The stack error trap will occur on a subsequent push operation. Thus, for example, if it is desirable to cause a stack error trap when the stack grows beyond address 2000h in RAM, initialize the SPLIM with the value, 1FFEh.

Similarly, a Stack Pointer underflow (stack error) trap is generated when the Stack Pointer address is found to be less than 0800h. This prevents the stack from interfering with the SFR space.

A write to the SPLIM register should not be immediately followed by an indirect read operation using W15.

FIGURE 4-6: CALL STACK FRAME

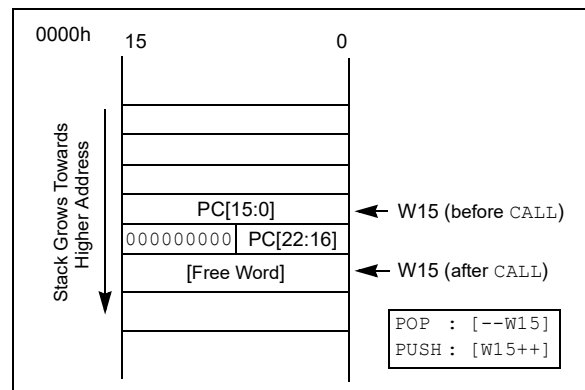

PIC24FJ256GA705 FAMILY

4.3 Interfacing Program and Data Memory Spaces

The PIC24F architecture uses a 24-bit wide program space and 16-bit wide Data Space. The architecture is also a modified Harvard scheme, meaning that data can also be present in the program space. To use these data successfully, they must be accessed in a way that preserves the alignment of information in both spaces.

Aside from normal execution, the PIC24F architecture provides two methods by which program space can be accessed during operation:

- Using table instructions to access individual bytes or words anywhere in the program space
- Remapping a portion of the program space into the Data Space (Program Space Visibility)

Table instructions allow an application to read or write to small areas of the program memory. This makes the method ideal for accessing data tables that need to be updated from time to time. It also allows access to all bytes of the program word. The remapping method allows an application to access a large block of data on a read-only basis, which is ideal for look-ups from a large table of static data. It can only access the least significant word of the program word.

4.3.1 ADDRESSING PROGRAM SPACE

Since the address ranges for the data and program spaces are 16 and 24 bits, respectively, a method is needed to create a 23-bit or 24-bit program address from 16-bit data registers. The solution depends on the interface method to be used.

For table operations, the 8-bit Table Memory Page Address register (TBLPAG) is used to define a 32K word region within the program space. This is concatenated with a 16-bit EA to arrive at a full 24-bit program space address. In this format, the MSBs of TBLPAG are used to determine if the operation occurs in the user memory (TBLPAG[7] = 0) or the configuration memory (TBLPAG[7] = 1).

For remapping operations, the 10-bit Extended Data Space Read register (DSRPAG) is used to define a 16K word page in the program space. When the Most Significant bit (MSb) of the EA is '1', and the MSb (bit 9) of DSRPAG is '1', the lower eight bits of DSRPAG are concatenated with the lower 15 bits of the EA to form a 23-bit program space address. The DSRPAG[8] bit decides whether the lower word (when the bit is '0') or the higher word (when the bit is '1') of program memory is mapped. Unlike table operations, this strictly limits remapping operations to the user memory area.

Table 4-14 and Figure 4-7 show how the program EA is created for table operations and remapping accesses from the data EA. Here, P[23:0] refers to a program space word, whereas D[15:0] refers to a Data Space word.

TABLE 4-14: PROGRAM SPACE ADDRESS CONSTRUCTION

Access Type	Access Space	Program Space Address				
		[23]	[22:16]	[15]	[14:1]	[0]
Instruction Access (Code Execution)	User	0	PC[22:1]			0
		0xx xxxx xxxx xxxx xxxx xxx0				
TBLRD/TBLWT (Byte/Word Read/Write)	User	TBLPAG[7:0]		Data EA[15:0]		
		0xxx xxxx		xxxx xxxx xxxx xxxx		
	Configuration	TBLPAG[7:0]		Data EA[15:0]		
		1xxx xxxx		xxxx xxxx xxxx xxxx		
Program Space Visibility (Block Remap/Read)	User	0	DSRPAG[7:0] ⁽²⁾		Data EA[14:0] ⁽¹⁾	
		0	xxxx xxxx		xxx xxxx xxxx xxxx	

Note 1: Data EA[15] is always '1' in this case, but is not used in calculating the program space address. Bit 15 of the address is DSRPAG[0].

2: DSRPAG[9] is always '1' in this case. DSRPAG[8] decides whether the lower word or higher word of program memory is read. When DSRPAG[8] is '0', the lower word is read, and when it is '1', the higher word is read.

FIGURE 4-7: DATA ACCESS FROM PROGRAM SPACE ADDRESS GENERATION

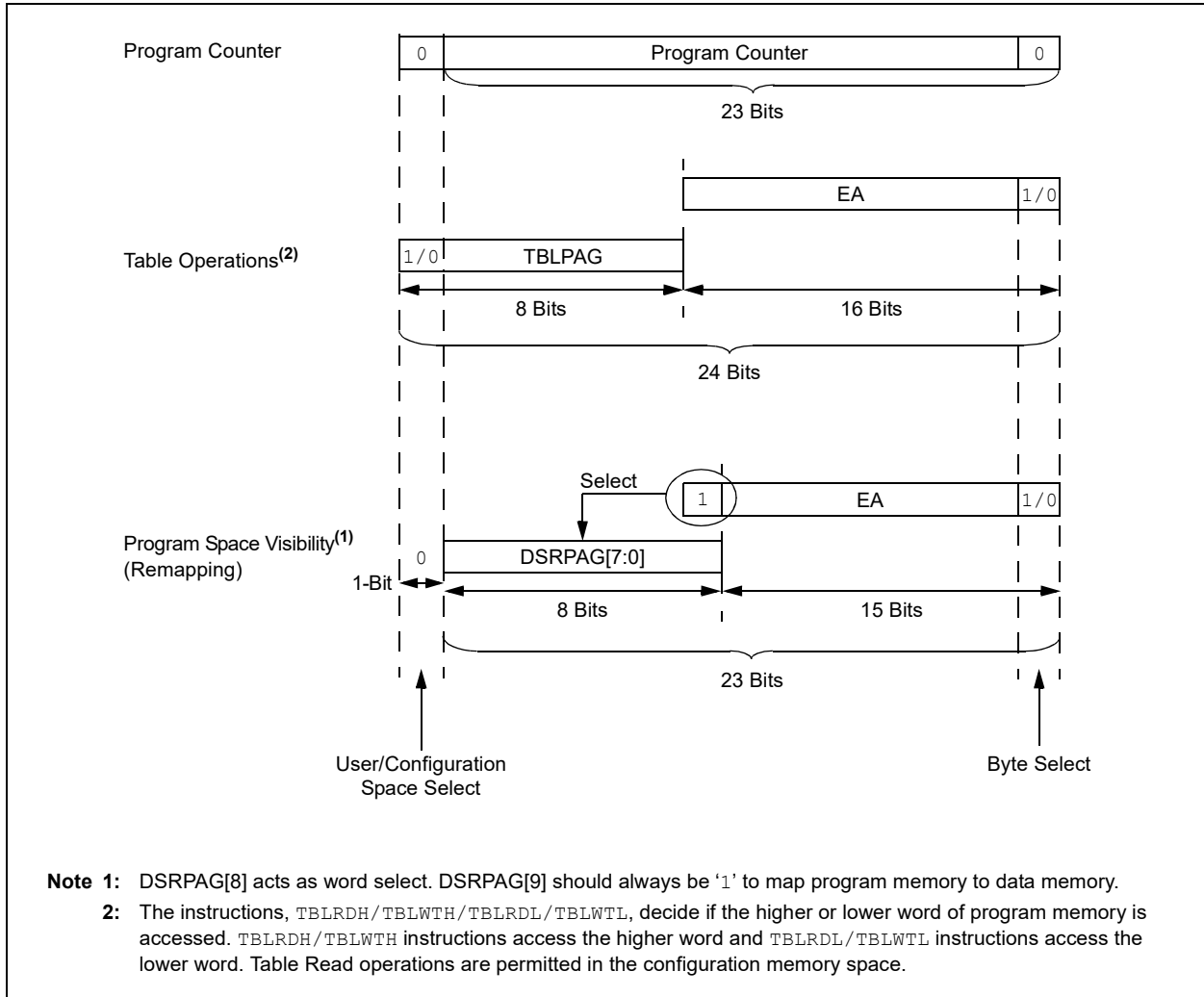

PIC24FJ256GA705 FAMILY

4.3.2 DATA ACCESS FROM PROGRAM MEMORY USING TABLE INSTRUCTIONS

The `TBLRDL` and `TBLWTL` instructions offer a direct method of reading or writing the lower word of any address within the program space without going through Data Space. The `TBLRDH` and `TBLWTH` instructions are the only method to read or write the upper eight bits of a program space word as data.

The PC is incremented by two for each successive 24-bit program word. This allows program memory addresses to directly map to Data Space addresses. Program memory can thus be regarded as two, 16-bit word-wide address spaces, residing side by side, each with the same address range. `TBLRDL` and `TBLWTL` access the space which contains the least significant data word, and `TBLRDH` and `TBLWTH` access the space which contains the upper data byte.

Two table instructions are provided to move byte or word-sized (16-bit) data to and from program space. Both function as either byte or word operations.

1. `TBLRDL` (Table Read Low): In Word mode, it maps the lower word of the program space location (`P[15:0]`) to a data address (`D[15:0]`). In Byte mode, either the upper or lower byte of the lower program word is mapped to the lower byte of a data address. The upper byte is selected when byte select is '1'; the lower byte is selected when it is '0'.

2. `TBLRDH` (Table Read High): In Word mode, it maps the entire upper word of a program address (`P[23:16]`) to a data address. Note that `D[15:8]`, the 'phantom' byte, will always be '0'.

In Byte mode, it maps the upper or lower byte of the program word to `D[7:0]` of the data address, as above. Note that the data will always be '0' when the upper 'phantom' byte is selected (byte select = 1).

In a similar fashion, two table instructions, `TBLWTH` and `TBLWTL`, are used to write individual bytes or words to a program space address. The details of their operation are described in [Section 6.0 "Flash Program Memory"](#).

For all table operations, the area of program memory space to be accessed is determined by the Table Memory Page Address register (`TBLPAG`). `TBLPAG` covers the entire program memory space of the device, including user and configuration spaces. When `TBLPAG[7] = 0`, the table page is located in the user memory space. When `TBLPAG[7] = 1`, the page is located in configuration space.

Note: Only Table Read operations will execute in the configuration memory space where Device IDs are located. Table Write operations are not allowed.

FIGURE 4-8: ACCESS PROGRAM MEMORY WITH TABLE INSTRUCTIONS

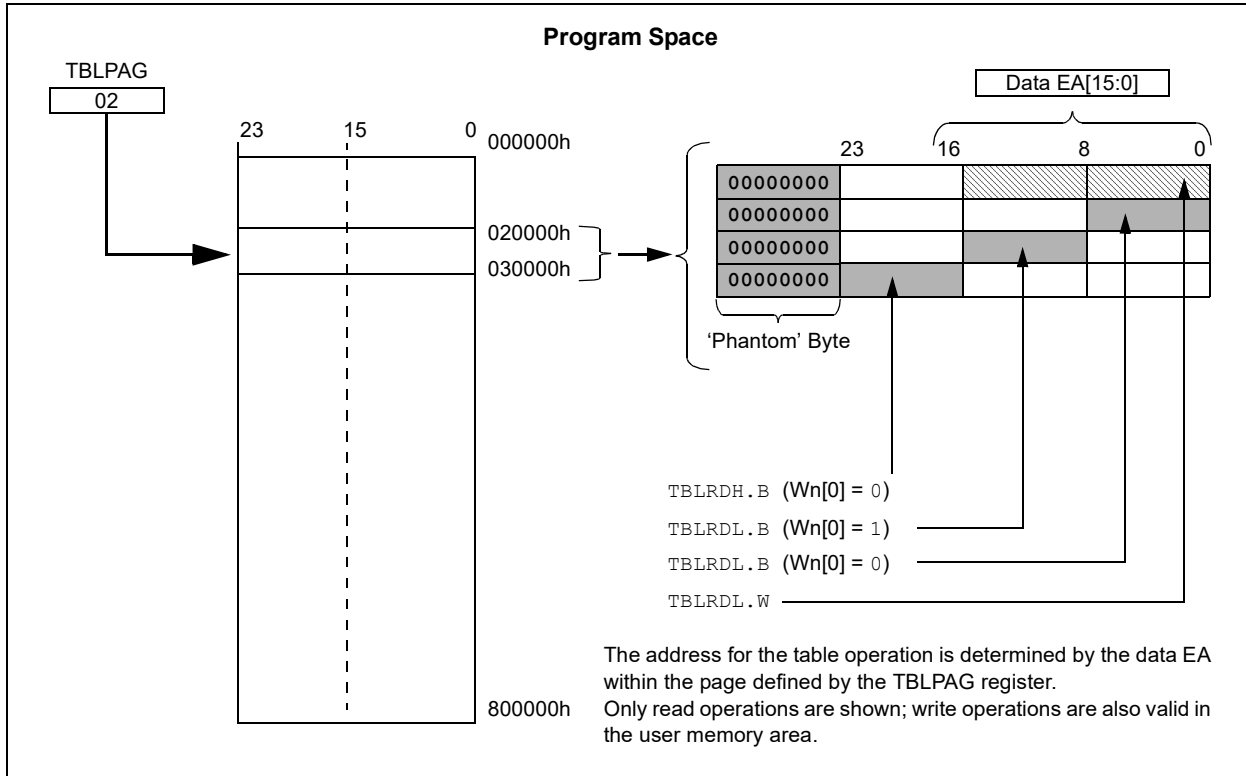

4.3.3 READING DATA FROM PROGRAM MEMORY USING EDS

The upper 32 Kbytes of Data Space may optionally be mapped into any 16K word page of the program space. This provides transparent access of stored constant data from the Data Space without the need to use special instructions (i.e., `TBLRDL/H`).

Program space access through the Data Space occurs when the MSb of EA is '1' and the `DSRPAG[9]` bit is also '1'. The lower eight bits of `DSRPAG` are concatenated to the `Wn[14:0]` bits to form a 23-bit EA to access program memory. The `DSRPAG[8]` decides which word should be addressed; when the bit is '0', the lower word, and when '1', the upper word of the program memory is accessed.

The entire program memory is divided into 512 EDS pages, from 200h to 3FFh, each consisting of 16K words of data. Pages, 200h to 2FFh, correspond to the lower words of the program memory, while 300h to 3FFh correspond to the upper words of the program memory.

Using this EDS technique, the entire program memory can be accessed. Previously, the access to the upper word of the program memory was not supported.

Table 4-15 provides the corresponding 23-bit EDS address for program memory with EDS page and source addresses.

For operations that use PSV and are executed outside a `REPEAT` loop, the `MOV` and `MOV.D` instructions will require one instruction cycle in addition to the specified execution time. All other instructions will require two instruction cycles in addition to the specified execution time.

For operations that use PSV, which are executed inside a `REPEAT` loop, there will be some instances that require two instruction cycles in addition to the specified execution time of the instruction:

- Execution in the first iteration
- Execution in the last iteration
- Execution prior to exiting the loop due to an interrupt
- Execution upon re-entering the loop after an interrupt is serviced

Any other iteration of the `REPEAT` loop will allow the instruction accessing data, using PSV, to execute in a single cycle.

TABLE 4-15: EDS PROGRAM ADDRESS WITH DIFFERENT PAGES AND ADDRESSES

DSRPAG (Data Space Read Register)	Source Address while Indirect Addressing	23-Bit EA Pointing to EDS	Comment
200h • • • 2FFh	8000h to FFFFh	000000h to 007FFEh • • • 7F8000h to 7FFFFEh	Lower words of 4M program instructions (8 Mbytes) for read operations only.
300h • • • 3FFh		000001h to 007FFFh • • • 7F8001h to 7FFFFFh	Upper words of 4M program instructions (4 Mbytes remaining; 4 Mbytes are phantom bytes) for read operations only.
000h		Invalid Address	Address error trap. ⁽¹⁾

Note 1: When the source/destination address is above 8000h and `DSRPAG/DSWPAG` is '0', an address error trap will occur.

EXAMPLE 4-3: EDS READ CODE FROM PROGRAM MEMORY IN ASSEMBLY

```

; Set the EDS page from where the data to be read
mov    #0x0202, w0
mov    w0, DSRPAG           ;page 0x202, consisting lower words, is selected for read
mov    #0x000A, w1         ;select the location (0x0A) to be read
bset   w1, #15             ;set the MSB of the base address, enable EDS mode
;Read a byte from the selected location
mov.b  [w1++], w2          ;read Low byte
mov.b  [w1++], w3          ;read High byte
;Read a word from the selected location
mov    [w1], w2            ;
;Read Double - word from the selected location
mov.d  [w1], w2            ;two word read, stored in w2 and w3
    
```

PIC24FJ256GA705 FAMILY

FIGURE 4-9: PROGRAM SPACE VISIBILITY OPERATION TO ACCESS LOWER WORD

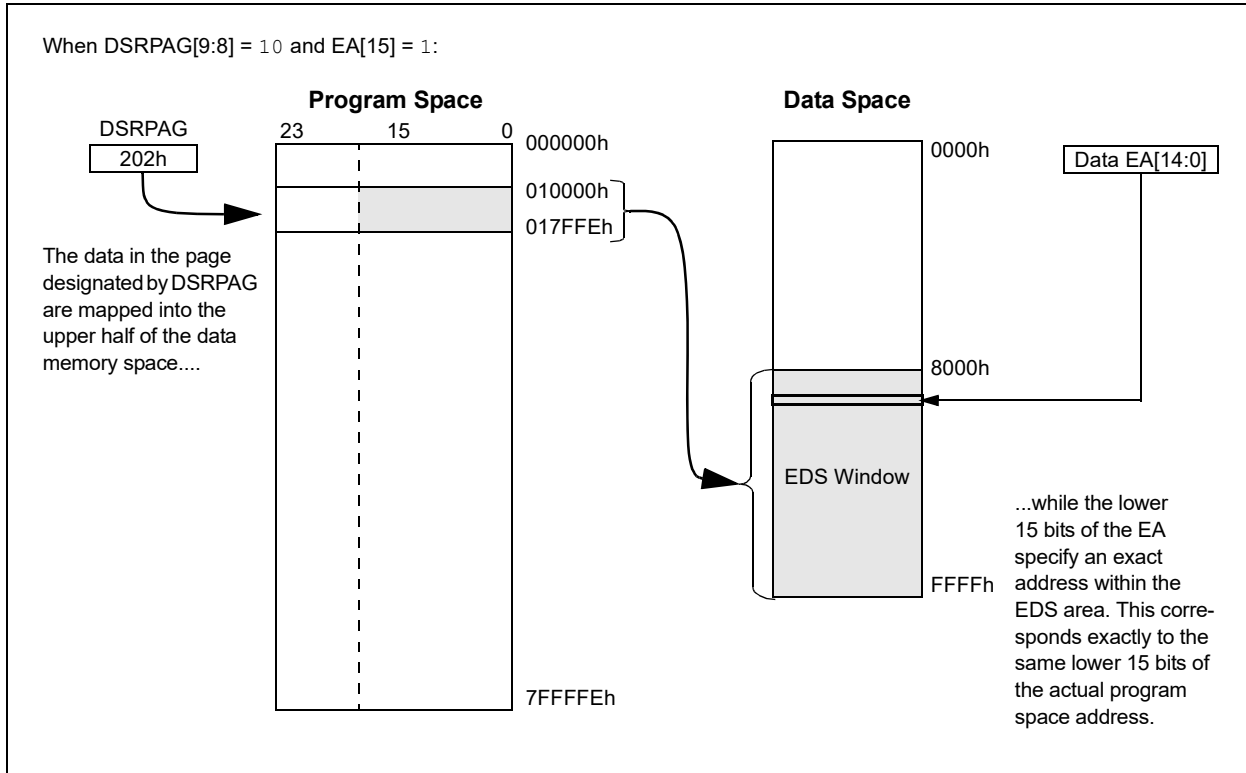
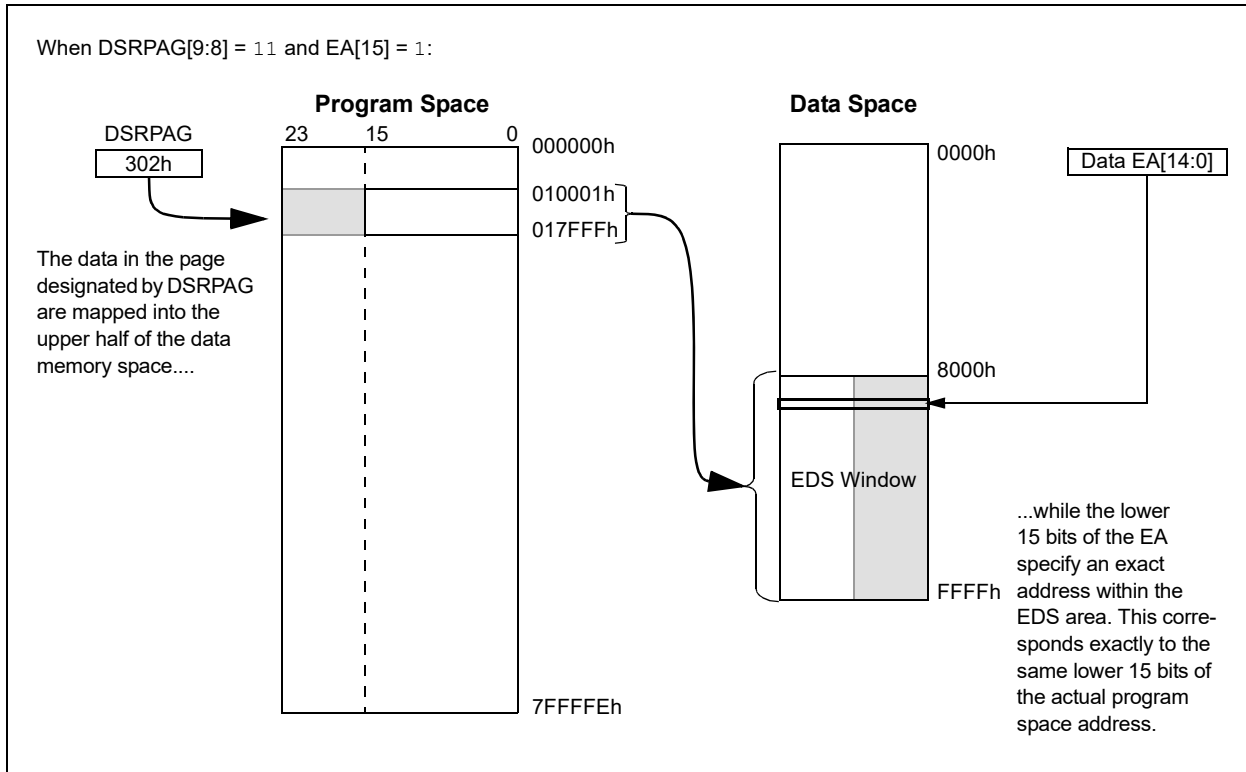

FIGURE 4-10: PROGRAM SPACE VISIBILITY OPERATION TO ACCESS UPPER WORD



5.0 DIRECT MEMORY ACCESS CONTROLLER (DMA)

Note: This data sheet summarizes the features of the PIC24FJ256GA705 family of devices. It is not intended to be a comprehensive reference source. To complement the information in this data sheet, refer to “**Direct Memory Access Controller (DMA)**” (www.microchip.com/DS30009742) in the “*dsPIC33/PIC24 Family Reference Manual*”. The information in this data sheet supersedes the information in the FRM.

The Direct Memory Access (DMA) Controller is designed to service high throughput data peripherals operating on the SFR bus, allowing them to access data memory directly and alleviating the need for CPU-intensive management. By allowing these data-intensive peripherals to share their own data path, the main data bus is also deloaded, resulting in additional power savings.

The DMA Controller functions both as a peripheral and a direct extension of the CPU. It is located on the microcontroller data bus between the CPU and DMA-enabled peripherals, with direct access to SRAM. This partitions the SFR bus into two buses, allowing the DMA Controller access to the DMA-capable peripherals located on the new DMA SFR bus. The controller serves as a Master device on the DMA SFR bus, controlling data flow from DMA-capable peripherals.

The controller also monitors CPU instruction processing directly, allowing it to be aware of when the CPU requires access to peripherals on the DMA bus and automatically relinquishing control to the CPU as needed. This increases the effective bandwidth for handling data without DMA operations causing a processor Stall. This makes the controller essentially transparent to the user.

The DMA Controller has these features:

- Six Independent and Independently Programmable Channels
- Concurrent Operation with the CPU (no DMA caused Wait states)
- DMA Bus Arbitration
- Five Programmable Address modes
- Four Programmable Transfer modes
- Four Flexible Internal Data Transfer modes
- Byte or Word Support for Data Transfer
- 16-Bit Source and Destination Address Register for Each Channel, Dynamically Updated and Reloadable
- 16-Bit Transaction Count Register, Dynamically Updated and Reloadable
- Upper and Lower Address Limit Registers
- Counter Half-Full Level Interrupt
- Software-Triggered Transfer
- Null Write mode for Symmetric Buffer Operations

A simplified block diagram of the DMA Controller is shown in [Figure 5-1](#).

FIGURE 5-1: DMA FUNCTIONAL BLOCK DIAGRAM

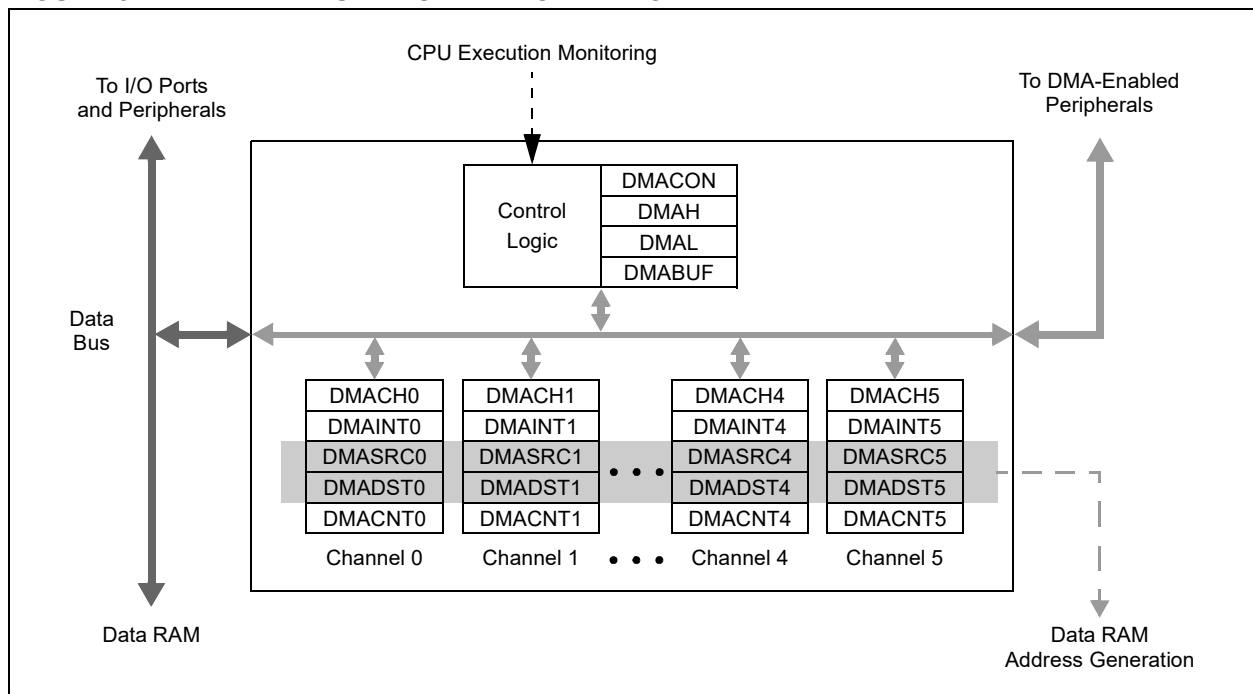

PIC24FJ256GA705 FAMILY

5.1 Summary of DMA Operations

The DMA Controller is capable of moving data between addresses according to a number of different parameters. Each of these parameters can be independently configured for any transaction; in addition, any or all of the DMA channels can independently perform a different transaction at the same time. Transactions are classified by these parameters:

- Source and destination (SFRs and data RAM)
- Data size (byte or word)
- Trigger source
- Transfer mode (One-Shot, Repeated or Continuous)
- Addressing modes (Fixed Address or Address Blocks, with or without Address Increment/Decrement)

In addition, the DMA Controller provides channel priority arbitration for all channels.

5.1.1 SOURCE AND DESTINATION

Using the DMA Controller, data may be moved between any two addresses in the Data Space. The SFR space (0000h to 07FFh), or the data RAM space (0800h to FFFFh), can serve as either the source or the destination. Data can be moved between these areas in either direction or between addresses in either area. The four different combinations are shown in [Figure 5-2](#).

If it is necessary to protect areas of data RAM, the DMA Controller allows the user to set upper and lower address boundaries for operations in the Data Space above the SFR space. The boundaries are set by the DMAH and DMAL Limit registers. If a DMA channel attempts an operation outside of the address boundaries, the transaction is terminated and an interrupt is generated.

5.1.2 DATA SIZE

The DMA Controller can handle both 8-bit and 16-bit transactions. Size is user-selectable using the SIZE bit (DMACHn[1]). By default, each channel is configured for word-sized transactions. When byte-sized transactions are chosen, the LSb of the source and/or destination address determines if the data represent the upper or lower byte of the data RAM location.

5.1.3 TRIGGER SOURCE

The DMA Controller can use any one of the device's interrupt sources to initiate a transaction. The DMA Trigger sources are listed in reverse order of their natural interrupt priority and are shown in [Table 5-1](#).

Since the source and destination addresses for any transaction can be programmed independently of the trigger source, the DMA Controller can use any trigger to perform an operation on any peripheral. This also allows DMA channels to be cascaded to perform more complex transfer operations.

5.1.4 TRANSFER MODE

The DMA Controller supports four types of data transfers, based on the volume of data to be moved for each trigger.

- One-Shot: A single transaction occurs for each trigger.
- Continuous: A series of back-to-back transactions occur for each trigger; the number of transactions is determined by the DMACNTn transaction counter.
- Repeated One-Shot: A single transaction is performed repeatedly, once per trigger, until the DMA channel is disabled.
- Repeated Continuous: A series of transactions are performed repeatedly, one cycle per trigger, until the DMA channel is disabled.

All transfer modes allow the option to have the source and destination addresses, and counter value automatically reloaded after the completion of a transaction. Repeated mode transfers do this automatically.

5.1.5 ADDRESSING MODES

The DMA Controller also supports transfers between single addresses or address ranges. The four basic options are:

- Fixed-to-Fixed: Between two constant addresses
- Fixed-to-Block: From a constant source address to a range of destination addresses
- Block-to-Fixed: From a range of source addresses to a single, constant destination address
- Block-to-Block: From a range to source addresses to a range of destination addresses

The option to select auto-increment or auto-decrement of source and/or destination addresses is available for Block Addressing modes.

In addition to the four basic modes, the DMA Controller also supports Peripheral Indirect Addressing (PIA) mode, where the source or destination address is generated jointly by the DMA Controller and a PIA-capable peripheral. When enabled, the DMA channel provides a base source and/or destination address, while the peripheral provides a fixed range offset address.

For PIC24FJ256GA705 family devices, the 12-bit A/D Converter module is the only PIA-capable peripheral. Details for its use in PIA mode are provided in [Section 24.0 "12-Bit A/D Converter with Threshold Detect"](#).

FIGURE 5-2: TYPES OF DMA DATA TRANSFERS

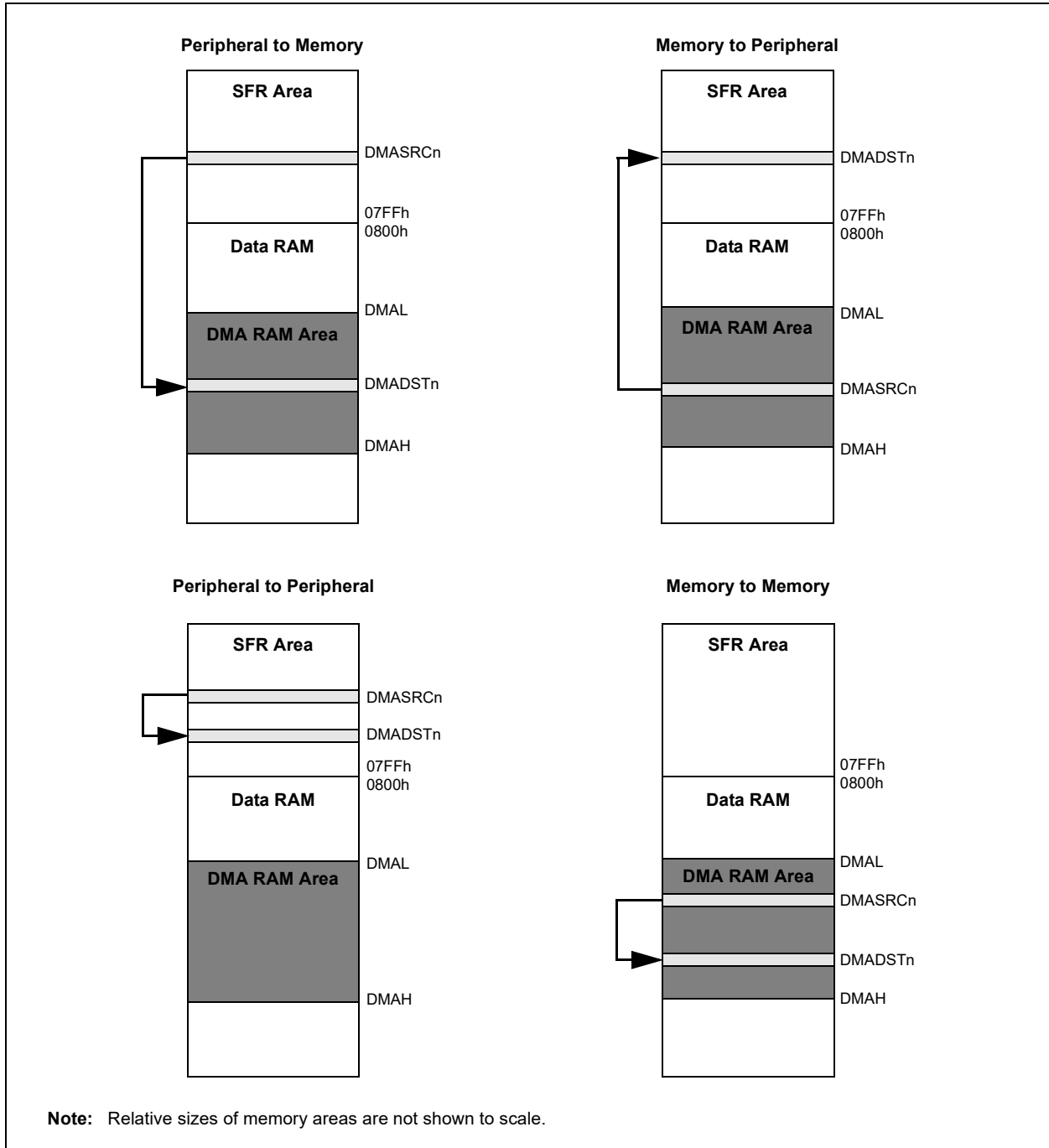

PIC24FJ256GA705 FAMILY

5.1.6 CHANNEL PRIORITY

Each DMA channel functions independently of the others, but also competes with the others for access to the data and DMA buses. When access collisions occur, the DMA Controller arbitrates between the channels using a user-selectable priority scheme. Two schemes are available:

- Round-Robin: When two or more channels collide, the lower numbered channel receives priority on the first collision. On subsequent collisions, the higher numbered channels each receive priority based on their channel number.
- Fixed: When two or more channels collide, the lowest numbered channel always receives priority, regardless of past history; however, any channel being actively processed is not available for an immediate retrigger. If a higher priority channel is continually requesting service, it will be scheduled for service after the next lower priority channel with a pending request.

5.2 Typical Setup

To set up a DMA channel for a basic data transfer:

1. Enable the DMA Controller ($DMAEN = 1$) and select an appropriate channel priority scheme by setting or clearing $PRSEL$.
2. Program $DMAH$ and $DMAL$ with the appropriate upper and lower address boundaries for data RAM operations.
3. Select the DMA channel to be used and disable its operation ($CHEN = 0$).
4. Program the appropriate source and destination addresses for the transaction into the channel's $DMASRCn$ and $DMADSTn$ registers. For PIA mode addressing, use the base address value.
5. Program the $DMACNTn$ register for the number of triggers per transfer (One-Shot or Continuous modes) or the number of words (bytes) to be transferred (Repeated modes).
6. Set or clear the $SIZE$ bit to select the data size.
7. Program the $TRMODE[1:0]$ bits to select the Data Transfer mode.
8. Program the $SAMODE[1:0]$ and $DAMODE[1:0]$ bits to select the addressing mode.
9. Enable the DMA channel by setting $CHEN$.
10. Enable the trigger source interrupt.

5.3 Peripheral Module Disable

Unlike other peripheral modules, the channels of the DMA Controller cannot be individually powered down using the Peripheral Module Disable (PMD) registers. Instead, the channels are controlled as two groups. The $DMA0MD$ bit ($PMD7[4]$) selectively controls $DMACH0$ through $DMACH3$. The $DMA1MD$ bit ($PMD7[5]$) controls $DMACH4$ and $DMACH5$. Setting both bits effectively disables the DMA Controller.

5.4 DMA Registers

The DMA Controller uses a number of registers to control its operation. The number of registers depends on the number of channels implemented for a particular device.

There are always four module-level registers (one control and three buffer/address):

- $DMACON$: DMA Engine Control Register ([Register 5-1](#))
- $DMAH$ and $DMAL$: DMA High and Low Address Limit Registers
- $DMABUF$: DMA Data Buffer

Each of the DMA channels implements five registers (two control and three buffer/address):

- $DMACHn$: DMA Channel n Control Register ([Register 5-2](#))
- $DMINTn$: DMA Channel n Interrupt Register ([Register 5-3](#))
- $DMASRCn$: DMA Data Source Address Pointer for Channel n
- $DMADSTn$: DMA Data Destination Address Pointer for Channel n
- $DMACNTn$: DMA Transaction Counter for Channel n

For PIC24FJ256GA705 family devices, there are a total of 34 registers.

PIC24FJ256GA705 FAMILY

REGISTER 5-1: DMACON: DMA ENGINE CONTROL REGISTER

R/W-0	U-0	U-0	U-0	U-0	U-0	U-0	U-0
DMAEN	—	—	—	—	—	—	—
bit 15							bit 8

U-0	U-0	U-0	U-0	U-0	U-0	U-0	R/W-0
—	—	—	—	—	—	—	PRSEL
bit 7							bit 0

Legend:

R = Readable bit

W = Writable bit

U = Unimplemented bit, read as '0'

-n = Value at POR

'1' = Bit is set

'0' = Bit is cleared

x = Bit is unknown

- bit 15 **DMAEN:** DMA Module Enable bit
 1 = Enables module
 0 = Disables module and terminates all active DMA operation(s)
- bit 14-1 **Unimplemented:** Read as '0'
- bit 0 **PRSEL:** Channel Priority Scheme Selection bit
 1 = Round-robin scheme
 0 = Fixed priority scheme

PIC24FJ256GA705 FAMILY

REGISTER 5-2: DMACHn: DMA CHANNEL n CONTROL REGISTER

U-0	U-0	U-0	r-0	U-0	R/W-0	R/W-0	R/W-0
—	—	—	—	—	NULLW	RELOAD ⁽¹⁾	CHREQ ⁽³⁾
bit 15						bit 8	

R/W-0	R/W-0	R/W-0	R/W-0	R/W-0	R/W-0	R/W-0	R/W-0
SAMODE1	SAMODE0	DAMODE1	DAMODE0	TRMODE1	TRMODE0	SIZE	CHEN
bit 7						bit 0	

Legend:	r = Reserved bit		
R = Readable bit	W = Writable bit	U = Unimplemented bit, read as '0'	
-n = Value at POR	'1' = Bit is set	'0' = Bit is cleared	x = Bit is unknown

- bit 15-13 **Unimplemented:** Read as '0'
- bit 12 **Reserved:** Maintain as '0'
- bit 11 **Unimplemented:** Read as '0'
- bit 10 **NULLW:** Null Write Mode bit
 1 = A dummy write is initiated to DMASRCn for every write to DMADSTn
 0 = No dummy write is initiated
- bit 9 **RELOAD:** Address and Count Reload bit⁽¹⁾
 1 = DMASRCn, DMADSTn and DMACNTn registers are reloaded to their previous values upon the start of the next operation
 0 = DMASRCn, DMADSTn and DMACNTn are not reloaded on the start of the next operation⁽²⁾
- bit 8 **CHREQ:** DMA Channel Software Request bit⁽³⁾
 1 = A DMA request is initiated by software; automatically cleared upon completion of a DMA transfer
 0 = No DMA request is pending
- bit 7-6 **SAMODE[1:0]:** Source Address Mode Selection bits
 11 = DMASRCn is used in Peripheral Indirect Addressing and remains unchanged
 10 = DMASRCn is decremented based on the SIZE bit after a transfer completion
 01 = DMASRCn is incremented based on the SIZE bit after a transfer completion
 00 = DMASRCn remains unchanged after a transfer completion
- bit 5-4 **DAMODE[1:0]:** Destination Address Mode Selection bits
 11 = DMADSTn is used in Peripheral Indirect Addressing and remains unchanged
 10 = DMADSTn is decremented based on the SIZE bit after a transfer completion
 01 = DMADSTn is incremented based on the SIZE bit after a transfer completion
 00 = DMADSTn remains unchanged after a transfer completion
- bit 3-2 **TRMODE[1:0]:** Transfer Mode Selection bits
 11 = Repeated Continuous mode
 10 = Continuous mode
 01 = Repeated One-Shot mode
 00 = One-Shot mode
- bit 1 **SIZE:** Data Size Selection bit
 1 = Byte (8-bit)
 0 = Word (16-bit)
- bit 0 **CHEN:** DMA Channel Enable bit
 1 = The corresponding channel is enabled
 0 = The corresponding channel is disabled

- Note 1:** Only the original DMACNTn is required to be stored to recover the original DMASRCn and DMADSTn.
- Note 2:** DMASRCn, DMADSTn and DMACNTn are always reloaded in Repeated mode transfers (DMACHn[2] = 1), regardless of the state of the RELOAD bit.
- Note 3:** The number of transfers executed while CHREQ is set depends on the configuration of TRMODE[1:0].

REGISTER 5-3: DMAINTn: DMA CHANNEL n INTERRUPT REGISTER

R-0	R/W-0	R/W-0	R/W-0	R/W-0	R/W-0	R/W-0	R/W-0
DBUFWF ⁽¹⁾	CHSEL6	CHSEL5	CHSEL4	CHSEL3	CHSEL2	CHSEL1	CHSEL0
bit 15							bit 8

R/W-0	R/W-0	R/W-0	R/W-0	R/W-0	U-0	U-0	R/W-0
HIGHIF ^(1,2)	LOWIF ^(1,2)	DONEIF ⁽¹⁾	HALFIF ⁽¹⁾	OVRUNIF ⁽¹⁾	—	—	HALFEN
bit 7							bit 0

Legend:

R = Readable bit	W = Writable bit	U = Unimplemented bit, read as '0'
-n = Value at POR	'1' = Bit is set	'0' = Bit is cleared
		x = Bit is unknown

- bit 15 **DBUFWF:** DMA Buffered Data Write Flag bit⁽¹⁾
 1 = The content of the DMA buffer has not been written to the location specified in DMADSTn or DMASRCn in Null Write mode
 0 = The content of the DMA buffer has been written to the location specified in DMADSTn or DMASRCn in Null Write mode
- bit 14-8 **CHSEL[6:0]:** DMA Channel Trigger Selection bits
 See [Table 5-1](#) for a complete list.
- bit 7 **HIGHIF:** DMA High Address Limit Interrupt Flag bit^(1,2)
 1 = The DMA channel has attempted to access an address higher than DMAH or the upper limit of the data RAM space
 0 = The DMA channel has not invoked the high address limit interrupt
- bit 6 **LOWIF:** DMA Low Address Limit Interrupt Flag bit^(1,2)
 1 = The DMA channel has attempted to access the DMA SFR address lower than DMAL, but above the SFR range (07FFh)
 0 = The DMA channel has not invoked the low address limit interrupt
- bit 5 **DONEIF:** DMA Complete Operation Interrupt Flag bit⁽¹⁾
If CHEN = 1:
 1 = The previous DMA session has ended with completion
 0 = The current DMA session has not yet completed
If CHEN = 0:
 1 = The previous DMA session has ended with completion
 0 = The previous DMA session has ended without completion
- bit 4 **HALFIF:** DMA 50% Watermark Level Interrupt Flag bit⁽¹⁾
 1 = DMACNTn has reached the halfway point to 0000h
 0 = DMACNTn has not reached the halfway point
- bit 3 **OVRUNIF:** DMA Channel Overrun Flag bit⁽¹⁾
 1 = The DMA channel is triggered while it is still completing the operation based on the previous trigger
 0 = The overrun condition has not occurred
- bit 2-1 **Unimplemented:** Read as '0'
- bit 0 **HALFEN:** Halfway Completion Watermark bit
 1 = Interrupts are invoked when DMACNTn has reached its halfway point and at completion
 0 = An interrupt is invoked only at the completion of the transfer

- Note 1:** Setting these flags in software does not generate an interrupt.
Note 2: Testing for address limit violations (DMASRCn or DMADSTn is either greater than DMAH or less than DMAL) is NOT done before the actual access.

PIC24FJ256GA705 FAMILY

TABLE 5-1: DMA TRIGGER SOURCES

CHSEL[6:0]	Trigger (Interrupt)	CHSEL[6:0]	Trigger (Interrupt)
0000000	Off	1000001	UART2 TX Interrupt
0001001	MCCP4 IC/OC Interrupt	1000010	UART2 RX Interrupt
0001010	MCCP4 Timer Interrupt	1000011	UART2 Error Interrupt
0001011	MCCP3 IC/OC Interrupt	1000100	UART1 TX Interrupt
0001100	MCCP3 Timer Interrupt	1000101	UART1 RX Interrupt
0001101	MCCP2 IC/OC Interrupt	1000110	UART1 Error Interrupt
0001110	MCCP2 Timer Interrupt	1001011	DMA Channel 5 Interrupt
0001111	MCCP1 IC/OC Interrupt	1001100	DMA Channel 4 Interrupt
0010000	MCCP1 Timer Interrupt	1001101	DMA Channel 3 Interrupt
0010100	OC3 Interrupt	1001110	DMA Channel 2 Interrupt
0010101	OC2 Interrupt	1001111	DMA Channel 1 Interrupt
0010110	OC1 Interrupt	1010000	DMA Channel 0 Interrupt
0011010	IC3 Interrupt	1010001	A/D Interrupt
0011011	IC2 Interrupt	1010011	PMP Interrupt
0011100	IC1 Interrupt	1010100	HLVD Interrupt
0100000	SPI3 Receive Interrupt	1010101	CRC Interrupt
0100001	SPI3 Transmit Interrupt	1011011	CLC2 Out
0100010	SPI3 General Interrupt	1011100	CLC1 Out
0100011	SPI2 Receive Interrupt	1011110	RTCC Alarm Interrupt
0100100	SPI2 Transmit Interrupt	1100001	TMR3 Interrupt
0100101	SPI2 General Interrupt	1100010	TMR2 Interrupt
0100110	SPI1 Receive Interrupt	1100011	TMR1 Interrupt
0100111	SPI1 Transmit Interrupt	1100110	CTMU Trigger
0101000	SPI1 General Interrupt	1100111	Comparator Interrupt
0101111	I2C2 Slave Interrupt	1101000	INT4 Interrupt
0110000	I2C2 Master Interrupt	1101001	INT3 Interrupt
0110001	I2C2 Bus Collision Interrupt	1101010	INT2 Interrupt
0110010	I2C1 Slave Interrupt	1101011	INT1 Interrupt
0110011	I2C1 Master Interrupt	1101100	INT0 Interrupt
0110100	I2C1 Bus Collision Interrupt	1101101	Interrupt-on-Change (IOC) Interrupt

6.0 FLASH PROGRAM MEMORY

Note: This data sheet summarizes the features of this group of PIC24F devices. It is not intended to be a comprehensive reference source. For more information, refer to “**PIC24F Flash Program Memory**” (www.microchip.com/DS30009715) in the “*dsPIC33/PIC24 Family Reference Manual*”. The information in this data sheet supersedes the information in the FRM.

The PIC24FJ256GA705 family of devices contains internal Flash program memory for storing and executing application code. The program memory is readable, writable and erasable. The Flash memory can be programmed in four ways:

- In-Circuit Serial Programming™ (ICSP™)
- Run-Time Self-Programming (RTSP)
- JTAG
- Enhanced In-Circuit Serial Programming (Enhanced ICSP)

ICSP allows a PIC24FJ256GA705 family device to be serially programmed while in the end application circuit. This is simply done with two lines for the programming clock and programming data (named PGCx and PGDx, respectively), and three other lines for power (VDD), ground (VSS) and Master Clear (MCLR). This allows customers to manufacture boards with unprogrammed devices and then program the microcontroller just before shipping the product. This also allows the most recent firmware or a custom firmware to be programmed.

RTSP is accomplished using TBLRD (Table Read) and TBLWT (Table Write) instructions. With RTSP, the user may write program memory data in blocks of 128 instructions (384 bytes) at a time and erase program memory in blocks of 1024 instructions (3072 bytes) at a time.

The device implements a 7-bit Error Correcting Code (ECC). The NVM block contains a logic to write and read ECC bits to and from the Flash memory. The Flash is programmed at the same time as the corresponding ECC parity bits. The ECC provides improved resistance to Flash errors. ECC single bit errors can be transparently corrected; ECC double-bit errors result in a trap.

6.1 Table Instructions and Flash Programming

Regardless of the method used, all programming of Flash memory is done with the Table Read and Table Write instructions. These allow direct read and write access to the program memory space from the data memory while the device is in normal operating mode. The 24-bit target address in the program memory is formed using the TBLPAG[7:0] bits and the Effective Address (EA) from a W register, specified in the table instruction, as shown in Figure 6-1.

The TBLRDL and the TBLWTL instructions are used to read or write to bits[15:0] of program memory. TBLRDL and TBLWTL can access program memory in both Word and Byte modes.

The TBLRDH and TBLWTH instructions are used to read or write to bits[23:16] of program memory. TBLRDH and TBLWTH can also access program memory in Word or Byte mode.

FIGURE 6-1: ADDRESSING FOR TABLE REGISTERS

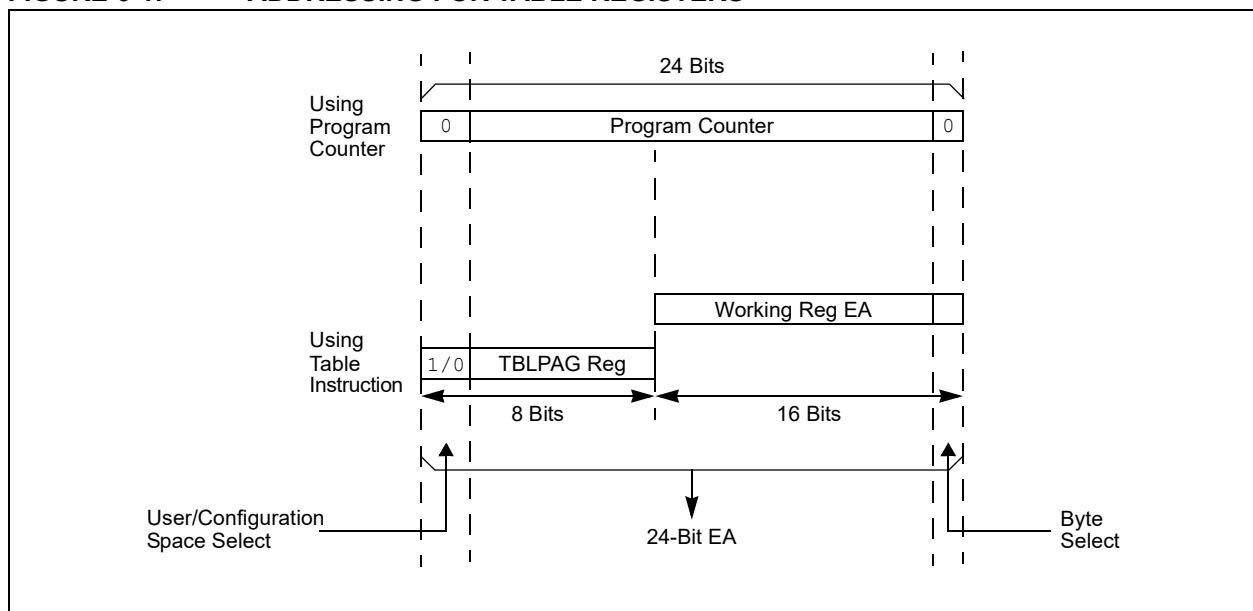

PIC24FJ256GA705 FAMILY

6.2 RTSP Operation

The PIC24F Flash program memory array is organized into rows of 128 instructions or 384 bytes. RTSP allows the user to erase blocks of eight rows (1024 instructions) at a time and to program one row at a time. It is also possible to program two instruction word blocks.

The 8-row erase blocks and single row write blocks are edge-aligned, from the beginning of program memory, on boundaries of 3072 bytes and 384 bytes, respectively.

When data are written to program memory using `TBLWT` instructions, the data are not written directly to memory. Instead, data written using Table Writes are stored in holding latches until the programming sequence is executed.

Any number of `TBLWT` instructions can be executed and a write will be successfully performed. However, 128 `TBLWT` instructions are required to write the full row of memory.

To ensure that no data are corrupted during a write, any unused address should be programmed with `FFFFFFh`. This is because the holding latches reset to an unknown state, so if the addresses are left in the Reset state, they may overwrite the locations on rows which were not rewritten.

The basic sequence for RTSP programming is to set the Table Pointer to point to the programming latches, do a series of `TBLWT` instructions to load the buffers and set the `NVMADRU/NVMADR` registers to point to the destination. Programming is performed by setting the control bits in the `NVMCON` register.

Data can be loaded in any order and the holding registers can be written to multiple times before performing a write operation. Subsequent writes, however, will wipe out any previous writes.

Note: Writing to a location multiple times without erasing is *not* recommended.

All of the Table Write operations are single-word writes (two instruction cycles), because only the buffers are written. A programming cycle is required for programming each row.

6.3 JTAG Operation

The PIC24F family supports JTAG boundary scan. Boundary scan can improve the manufacturing process by verifying pin to PCB connectivity.

6.4 Enhanced In-Circuit Serial Programming

Enhanced In-Circuit Serial Programming uses an on-board bootloader, known as the Program Executive (PE), to manage the programming process. Using an SPI data frame format, the Program Executive can erase, program and verify program memory. For more information on Enhanced ICSP, see the device programming specification.

Note: The PGD2/PGC2 port on 28-pin packages supports ICSP™ only, so Enhanced ICSP programming does not work.

6.5 Control Registers

There are four SFRs used to read and write the program Flash memory: `NVMCON`, `NVMADRU`, `NVMADR` and `NVMKEY`.

The `NVMCON` register ([Register 6-1](#)) controls which blocks are to be erased, which memory type is to be programmed and when the programming cycle starts.

`NVMKEY` is a write-only register that is used for write protection. To start a programming or erase sequence, the user must consecutively write `55h` and `AAh` to the `NVMKEY` register. Refer to [Section 6.6 “Programming Operations”](#) for further details.

The `NVMADRU/NVMADR` registers contain the upper byte and lower word of the destination of the NVM write or erase operation. Some operations (chip erase) operate on fixed locations and do not require an address value.

6.6 Programming Operations

A complete programming sequence is necessary for programming or erasing the internal Flash in RTSP mode. During a programming or erase operation, the processor stalls (waits) until the operation is finished. Setting the `WR` bit (`NVMCON[15]`) starts the operation and the `WR` bit is automatically cleared when the operation is finished.

PIC24FJ256GA705 FAMILY

REGISTER 6-1: NVMCON: FLASH MEMORY CONTROL REGISTER

HC/R/S-0 ⁽¹⁾	R/W-0 ⁽¹⁾	HSC/R-0 ⁽¹⁾	R/W-0	r-0	r-0	U-0	U-0
WR	WREN	WRERR	NVMSIDL	—	—	—	—
bit 15						bit 8	

U-0	U-0	U-0	U-0	R/W-0 ⁽¹⁾	R/W-0 ⁽¹⁾	R/W-0 ⁽¹⁾	R/W-0 ⁽¹⁾
—	—	—	—	NVMOP[3:0] ⁽²⁾			
bit 7				bit 0			

Legend:	S = Settable bit	HC = Hardware Clearable bit	r = Reserved bit
R = Readable bit	W = Writable bit	'0' = Bit is cleared	x = Bit is unknown
-n = Value at POR	'1' = Bit is set	U = Unimplemented bit, read as '0'	
HSC = Hardware Settable/Clearable bit			

- bit 15 **WR:** Write Control bit⁽¹⁾
 1 = Initiates a Flash memory program or erase operation; the operation is self-timed and the bit is cleared by hardware once the operation is complete
 0 = Program or erase operation is complete and inactive
- bit 14 **WREN:** Write Enable bit⁽¹⁾
 1 = Enables Flash program/erase operations
 0 = Inhibits Flash program/erase operations
- bit 13 **WRERR:** Write Sequence Error Flag bit⁽¹⁾
 1 = An improper program or erase sequence attempt, or termination has occurred (bit is set automatically on any set attempt of the WR bit)
 0 = The program or erase operation completed normally
- bit 12 **NVMSIDL:** NVM Stop in Idle bit
 1 = Removes power from the program memory when device enters Idle mode
 0 = Powers program memory in Standby mode when the device enters Idle mode
- bit 11-10 **Reserved:** Maintain as '0'
- bit 9-4 **Unimplemented:** Read as '0'
- bit 3-0 **NVMOP[3:0]:** NVM Operation Select bits^(1,2)
 1110 = Chip erases user memory (does not erase Device ID, customer OTP or executive memory)
 0100 = Unused
 0011 = Erases a page of program or executive memory
 0010 = Row programming operation
 0001 = Double-word programming operation

- Note 1:** These bits can only be reset on a Power-on Reset.
Note 2: All other combinations of NVMOP[3:0] are unimplemented.

PIC24FJ256GA705 FAMILY

6.6.1 PROGRAMMING ALGORITHM FOR FLASH PROGRAM MEMORY

The user can program one row of Flash program memory at a time. To do this, it is necessary to erase the 8-row erase block containing the desired row. The general process is:

1. Read eight rows of program memory (1024 instructions) and store in data RAM.
2. Update the program data in RAM with the desired new data.
3. Erase the block (see [Example 6-1](#)):
 - a) Set the NVMOPx bits (NVMCON[3:0]) to '0011' to configure for block erase. Set the WREN (NVMCON[14]) bit.
 - b) Write the starting address of the block to be erased into the NVMADRU/NVMADR registers.
 - c) Write 55h to NVMKEY.
 - d) Write AAh to NVMKEY.
 - e) Set the WR bit (NVMCON[15]). The erase cycle begins and the CPU stalls for the duration of the erase cycle. When the erase is done, the WR bit is cleared automatically.
4. Update the TBLPAG register to point to the programming latches on the device. Update the NVMADRU/NVMADR registers to point to the destination in the program memory.
5. Write the first 128 instructions from data RAM into the program memory buffers (see [Table 6-1](#)).
6. Write the program block to Flash memory:
 - a) Set the NVMOPx bits to '0010' to configure for row programming. Set the WREN bit.
 - b) Write 55h to NVMKEY.
 - c) Write AAh to NVMKEY.
 - d) Set the WR bit. The programming cycle begins and the CPU stalls for the duration of the write cycle. When the write to Flash memory is done, the WR bit is cleared automatically.
7. Repeat Steps 4 through 6, using the next available 128 instructions from the block in data RAM, by incrementing the value in NVMADRU/NVMADR until all 1024 instructions are written back to Flash memory.

For protection against accidental operations, the write initiate sequence for NVMKEY must be used to allow any erase or program operation to proceed. After the programming command has been executed, the user must wait for the programming time until programming is complete. The two instructions following the start of the programming sequence should be NOPs, as shown in [Example 6-2](#).

TABLE 6-1: EXAMPLE PAGE ERASE

Step 1: Set the NVMCON register to erase a page.	
MOV	#0x4003, W0
MOV	W0, NVMCON
Step 2: Load the address of the page to be erased into the NVMADR register pair.	
MOV	#PAGE_ADDR_LO, W0
MOV	W0, NVMADR
MOV	#PAGE_ADDR_HI, W0
MOV	W0, NVMADRU
Step 3: Set the WR bit.	
MOV	#0x55, W0
MOV	W0, NVMKEY
MOV	#0xAA, W0
MOV	W0, NVMKEY
BSET	NVMCON, #WR
NOP	
NOP	
NOP	

EXAMPLE 6-1: ERASING A PROGRAM MEMORY BLOCK ('C' LANGUAGE CODE)

```

// C example using MPLAB XC16
unsigned long progAddr = 0XXXXXXX; // Address of row to write
unsigned int offset;
//Set up pointer to the first memory location to be written
NVMADRU = progAddr>>16; // Initialize PM Page Boundary SFR
NVMADR = progAddr & 0xFFFF; // Initialize lower word of address
NVMCON = 0x4003; // Initialize NVMCON
asm("DISI #5"); // Block all interrupts with priority <7
// for next 5 instructions
__builtin_write_NVM(); // check function to perform unlock
// sequence and set WR
    
```

TABLE 6-2: CODE MEMORY PROGRAMMING EXAMPLE: ROW WRITES

Step 1: Set the NVMCON register to program 128 instruction words.	
MOV	#0x4002, W0
MOV	W0, NVMCON
Step 2: Initialize the TBLPAG register for writing to the latches.	
MOV	#0xFA, W12
MOV	W12, TBLPAG
Step 3: Load W0:W5 with the next four instruction words to program.	
MOV	#<LSW0>, W0
MOV	#<MSB1:MSB0>, W1
MOV	#<LSW1>, W2
MOV	#<LSW2>, W3
MOV	#<MSB3:MSB2>, W4
MOV	#<LSW3>, W5
Step 4: Set the Read Pointer (W6) and load the (next set of) write latches.	
CLR	W6
CLR	W7
TBLWTL	[W6++], [W7]
TBLWTH.B	[W6++], [W7++]
TBLWTH.B	[W6++], [++W7]
TBLWTL	[W6++], [W7++]
TBLWTL	[W6++], [W7]
TBLWTH.B	[W6++], [W7++]
TBLWTH.B	[W6++], [++W7]
TBLWTL	[W6++], [W7++]
Step 5: Repeat Steps 4 and 5, for a total of 32 times, to load the write latches with 128 instructions.	
Step 6: Set the NVMADRU/NVMADR register pair to point to the correct address.	
MOV	#DestinationAddress<15:0>, W3
MOV	#DestinationAddress<23:16>, W4
MOV	W3, NVMADR
MOV	W4, NVMADRU
Step 7: Execute the WR bit unlock sequence and initiate the write cycle.	
MOV	#0x55, W0
MOV	W0, NVMKEY
MOV	#0xAA, W0
MOV	W0, NVMKEY
BSET	NVMCON, #WR
NOP	
NOP	
NOP	

PIC24FJ256GA705 FAMILY

EXAMPLE 6-2: INITIATING A PROGRAMMING SEQUENCE

```
DISI    #5                ; Block all interrupts with priority <7
                          ; for next 5 instructions
MOV.B   #0x55, W0
MOV     W0, NVMKEY        ; Write the 0x55 key
MOV.B   #0xAA, W1        ;
MOV     W1, NVMKEY        ; Write the 0xAA key
BSET    NVMCON, #WR       ; Start the programming sequence
NOP                                           ; Required delays
NOP
BTSC    NVMCON, #15       ; and wait for it to be
BRA     $-2               ; completed
```

6.6.2 PROGRAMMING A DOUBLE WORD OF FLASH PROGRAM MEMORY

If a Flash location has been erased, it can be programmed using Table Write instructions to write two instruction words (2 x 24-bit) into the write latch. The TBLPAG register is loaded with the address of the write latches and the NVMADRU/NVMADR registers are loaded with the address of the first of the two instruction words to be programmed. The TBLWTL and TBLWTH

instructions write the desired data into the write latches. To configure the NVMCON register for a two-word write, set the NVMOPx bits (NVMCON[3:0]) to '0001'. The write is performed by executing the unlock sequence and setting the WR bit. An equivalent procedure in 'C', using the MPLAB[®] XC16 compiler and built-in hardware functions, is shown in [Example 6-3](#).

TABLE 6-3: PROGRAMMING A DOUBLE WORD OF FLASH PROGRAM MEMORY

Step 1: Initialize the TBLPAG register for writing to the latches.	
MOV	#0xFA, W12
MOV	W12, TBLPAG
Step 2: Load W0:W2 with the next two packed instruction words to program.	
MOV	#<LSW0>, W0
MOV	#<MSB1:MSB0>, W1
MOV	#<LSW1>, W2
Step 3: Set the Read Pointer (W6) and Write Pointer (W7), and load the (next set of) write latches.	
CLR	W6
CLR	W7
TBLWTL	[W6++], [W7]
TBLWTH.B	[W6++], [W7++]
TBLWTH.B	[W6++], [++W7]
TBLWTL.W	[W6++], [W7++]
Step 4: Set the NVMADRU/NVMADR register pair to point to the correct address.	
MOV	#DestinationAddress<15:0>, W3
MOV	#DestinationAddress<23:16>, W4
MOV	W3, NVMADR
MOV	W4, NVMADRU
Step 5: Set the NVMCON register to program two instruction words.	
MOV	#0x4001, W10
MOV	W10, NVMCON
NOP	
Step 6: Initiate the write cycle.	
MOV	#0x55, W1
MOV	W1, NVMKEY
MOV	#0xAA, W1
MOV	W1, NVMKEY
BSET	NVMCON, #WR
NOP	
NOP	
NOP	

PIC24FJ256GA705 FAMILY

EXAMPLE 6-3: PROGRAMMING A DOUBLE WORD OF FLASH PROGRAM MEMORY (‘C’ LANGUAGE CODE)

```
// C example using MPLAB XC16
unsigned long progAddr = 0xXXXXXX; // Address of word to program
unsigned int progData1L = 0XXXX; // Data to program lower word of word 1
unsigned char progData1H = 0XX; // Data to program upper byte of word 1
unsigned int progData2L = 0XXXX; // Data to program lower word of word 2
unsigned char progData2H = 0XX; // Data to program upper byte of word 2

//Set up NVMCON for word programming
NVMCON = 0x4001; // Initialize NVMCON
TBLPAG = 0xFA; // Point TBLPAG to the write latches

//Set up pointer to the first memory location to be written
NVMADRU = progAddr>>16; // Initialize PM Page Boundary SFR
NVMADR = progAddr & 0xFFFF; // Initialize lower word of address

//Perform TBLWT instructions to write latches
__builtin_tblwtl(0, progData1L); // Write word 1 to address low word
__builtin_tblwth(0, progData1H); // Write word 1 to upper byte
__builtin_tblwtl(1, progData2L); // Write word 2 to address low word
__builtin_tblwth(1, progData2H); // Write word 2 to upper byte
asm("DISI #5"); // Block interrupts with priority <7 for next 5
// instructions
__builtin_write_NVM(); // XC16 function to perform unlock sequence and set WR
```

7.0 RESETS

Note: This data sheet summarizes the features of this group of PIC24F devices. It is not intended to be a comprehensive reference source. For more information, refer to “Reset” (www.microchip.com/DS39712) in the “dsPIC33/PIC24 Family Reference Manual”. The information in this data sheet supersedes the information in the FRM.

The Reset module combines all Reset sources and controls the device Master Reset Signal, $\overline{\text{SYSRST}}$. The following is a list of device Reset sources:

- POR: Power-on Reset
- MCLR: Master Clear Pin Reset
- SWR: RESET Instruction
- WDT: Watchdog Timer Reset
- BOR: Brown-out Reset
- CM: Configuration Mismatch Reset
- TRAPR: Trap Conflict Reset
- IOPUWR: Illegal Opcode Reset
- UWR: Uninitialized W Register Reset

A simplified block diagram of the Reset module is shown in [Figure 7-1](#).

Any active source of Reset will make the $\overline{\text{SYSRST}}$ signal active. Many registers associated with the CPU and peripherals are forced to a known Reset state. Most registers are unaffected by a Reset; their status is unknown on POR and unchanged by all other Resets.

Note: Refer to the specific peripheral or CPU section of this manual for register Reset states.

All types of device Reset will set a corresponding status bit in the RCON register to indicate the type of Reset (see [Register 7-1](#)). A POR will clear all bits, except for the BOR and POR (RCON[1:0]) bits, which are set. The user may set or clear any bit at any time during code execution. The RCON bits only serve as status bits. Setting a particular Reset status bit in software will not cause a device Reset to occur.

The RCON register also has other bits associated with the Watchdog Timer and device power-saving states. The function of these bits is discussed in other sections of this data sheet.

Note: The status bits in the RCON register should be cleared after they are read so that the next RCON register values after a device Reset will be meaningful.

FIGURE 7-1: RESET SYSTEM BLOCK DIAGRAM

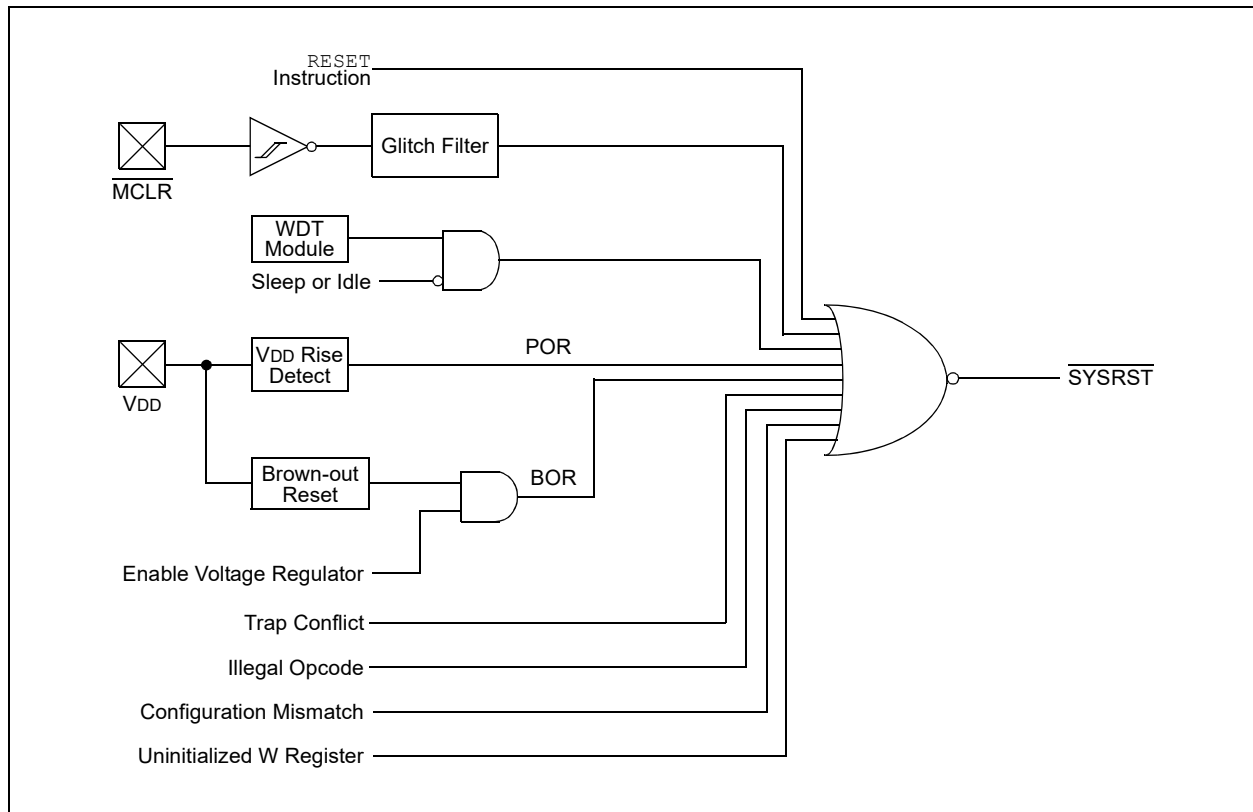

PIC24FJ256GA705 FAMILY

REGISTER 7-1: RCON: RESET CONTROL REGISTER

R/W-0	R/W-0	R/W-1	R/W-0	U-0	U-0	R/W-0	R/W-0
TRAPR ⁽¹⁾	IOPUWR ⁽¹⁾	SBOREN ⁽⁵⁾	RETEN ⁽²⁾	—	—	CM ⁽¹⁾	VREGS ⁽³⁾
bit 15						bit 8	

R/W-0	R/W-0	R/W-0	R/W-0	R/W-0	R/W-0	R/W-1	R/W-1
EXTR ⁽¹⁾	SWR ⁽¹⁾	SWDTEN ⁽⁴⁾	WDTO ⁽¹⁾	SLEEP ⁽¹⁾	IDLE ⁽¹⁾	BOR ⁽¹⁾	POR ⁽¹⁾
bit 7						bit 0	

Legend:

R = Readable bit

W = Writable bit

U = Unimplemented bit, read as '0'

-n = Value at POR

'1' = Bit is set

'0' = Bit is cleared

x = Bit is unknown

- bit 15 **TRAPR:** Trap Reset Flag bit⁽¹⁾
 1 = A Trap Conflict Reset has occurred
 0 = A Trap Conflict Reset has not occurred
- bit 14 **IOPUWR:** Illegal Opcode or Uninitialized W Register Access Reset Flag bit⁽¹⁾
 1 = An illegal opcode detection, an illegal address mode or Uninitialized W register is used as an Address Pointer and caused a Reset
 0 = An illegal opcode or Uninitialized W register Reset has not occurred
- bit 13 **SBOREN:** Software Control Over the BOR Function bit⁽⁵⁾
 1 = BOR is enabled
 0 = BOR is disabled
- bit 12 **RETEN:** Retention Mode Enable bit⁽²⁾
 1 = Retention mode is enabled while device is in Sleep mode (1.2V regulator supplies to the core)
 0 = Retention mode is disabled; normal voltage levels are present
- bit 11-10 **Unimplemented:** Read as '0'
- bit 9 **CM:** Configuration Word Mismatch Reset Flag bit⁽¹⁾
 1 = A Configuration Word Mismatch Reset has occurred
 0 = A Configuration Word Mismatch Reset has not occurred
- bit 8 **VREGS:** Fast Wake-up from Sleep bit⁽³⁾
 1 = Fast wake-up is enabled (uses more power)
 0 = Fast wake-up is disabled (uses less power)
- bit 7 **EXTR:** External Reset ($\overline{\text{MCLR}}$) Pin bit⁽¹⁾
 1 = A Master Clear (pin) Reset has occurred
 0 = A Master Clear (pin) Reset has not occurred
- bit 6 **SWR:** Software RESET (Instruction) Flag bit⁽¹⁾
 1 = A RESET instruction has been executed
 0 = A RESET instruction has not been executed

Note 1: All of the Reset status bits may be set or cleared in software. Setting one of these bits in software does not cause a device Reset.

2: If the $\overline{\text{LPCFG}}$ Configuration bit is '1' (unprogrammed), the retention regulator is disabled and the RETEN bit has no effect. Retention mode preserves the SRAM contents during Sleep.

3: Re-enabling the regulator after it enters Standby mode will add a delay, TVREG, when waking up from Sleep. Applications that do not use the voltage regulator should set this bit to prevent this delay from occurring.

4: If the FWDTEN[1:0] Configuration bits are '11' (unprogrammed), the WDT is always enabled, regardless of the SWDTEN bit setting.

5: The BOREN[1:0] (FPOR[1:0]) Configuration bits must be set to '01' in order for SBOREN to have an effect.

REGISTER 7-1: RCON: RESET CONTROL REGISTER (CONTINUED)

bit 5	SWDTEN: Software Enable/Disable of WDT bit ⁽⁴⁾ 1 = WDT is enabled 0 = WDT is disabled
bit 4	WDTO: Watchdog Timer Time-out Flag bit ⁽¹⁾ 1 = WDT time-out has occurred 0 = WDT time-out has not occurred
bit 3	SLEEP: Wake from Sleep Flag bit ⁽¹⁾ 1 = Device has been in Sleep mode 0 = Device has not been in Sleep mode
bit 2	IDLE: Wake-up from Idle Flag bit ⁽¹⁾ 1 = Device has been in Idle mode 0 = Device has not been in Idle mode
bit 1	BOR: Brown-out Reset Flag bit ⁽¹⁾ 1 = A Brown-out Reset has occurred (also set after a Power-on Reset) 0 = A Brown-out Reset has not occurred
bit 0	POR: Power-on Reset Flag bit ⁽¹⁾ 1 = A Power-on Reset has occurred 0 = A Power-on Reset has not occurred

- Note 1:** All of the Reset status bits may be set or cleared in software. Setting one of these bits in software does not cause a device Reset.
- 2:** If the LPCFG Configuration bit is '1' (unprogrammed), the retention regulator is disabled and the RETEN bit has no effect. Retention mode preserves the SRAM contents during Sleep.
- 3:** Re-enabling the regulator after it enters Standby mode will add a delay, T_{VREG} , when waking up from Sleep. Applications that do not use the voltage regulator should set this bit to prevent this delay from occurring.
- 4:** If the FWDTEN[1:0] Configuration bits are '11' (unprogrammed), the WDT is always enabled, regardless of the SWDTEN bit setting.
- 5:** The BOREN[1:0] (FPOR[1:0]) Configuration bits must be set to '01' in order for SBOREN to have an effect.

TABLE 7-1: RESET FLAG BIT OPERATION

Flag Bit	Setting Event	Clearing Event
TRAPR (RCON[15])	Trap Conflict Event	POR
IOPUWR (RCON[14])	Illegal Opcode or Uninitialized W Register Access	POR
CM (RCON[9])	Configuration Mismatch Reset	POR
EXTR (RCON[7])	\overline{MCLR} Reset	POR
SWR (RCON[6])	RESET Instruction	POR
WDTO (RCON[4])	WDT Time-out	CLRWDT, PWRSVAV Instruction, POR
SLEEP (RCON[3])	PWRSVAV #0 Instruction	POR
IDLE (RCON[2])	PWRSVAV #1 Instruction	POR
BOR (RCON[1])	POR, BOR	—
POR (RCON[0])	POR	—

Note: All Reset flag bits may be set or cleared by the user software.

PIC24FJ256GA705 FAMILY

7.1 Special Function Register Reset States

Most of the Special Function Registers (SFRs) associated with the PIC24F CPU and peripherals are reset to a particular value at a device Reset. The SFRs are grouped by their peripheral or CPU function and their Reset values are specified in each section of this manual.

The Reset value for each SFR does not depend on the type of Reset, with the exception of four registers. The Reset value for the Reset Control register, RCON, will depend on the type of device Reset. The Reset value for the Oscillator Control register, OSCCON, will depend on the type of Reset and the programmed values of the FNOSC[2:0] bits in the FOSCSEL Flash Configuration Word (see [Table 7-2](#)). The RCFGAL and NVMCON registers are only affected by a POR.

7.2 Device Reset Times

The Reset times for various types of device Reset are summarized in [Table 7-3](#). Note that the Master Reset Signal, $\overline{\text{SYSRST}}$, is released after the POR delay time expires.

The time at which the device actually begins to execute code will also depend on the system oscillator delays, which include the Oscillator Start-up Timer (OST) and the PLL lock time. The OST and PLL lock times occur in parallel with the applicable $\overline{\text{SYSRST}}$ delay times.

The Fail-Safe Clock Monitor (FSCM) delay determines the time at which the FSCM begins to monitor the system clock source after the $\overline{\text{SYSRST}}$ signal is released.

7.3 Brown-out Reset (BOR)

PIC24FJ256GA705 family devices implement a BOR circuit that provides the user with several configuration and power-saving options. The BOR is controlled by the BOREN[1:0] (FPOR[1:0]) Configuration bits.

When BOR is enabled, any drop of V_{DD} below the BOR threshold results in a device BOR. Threshold levels are described in [Section 32.1 “DC Characteristics”](#).

7.4 Clock Source Selection at Reset

If clock switching is enabled, the system clock source at device Reset is chosen, as shown in [Table 7-2](#). If clock switching is disabled, the system clock source is always selected according to the Oscillator Configuration bits. For more information, refer to “**Oscillator**” (www.microchip.com/DS39700) in the “*dsPIC33/PIC24 Family Reference Manual*”.

TABLE 7-2: OSCILLATOR SELECTION vs. TYPE OF RESET (CLOCK SWITCHING ENABLED)

Reset Type	Clock Source Determinant
POR	FNOSC[2:0] Configuration bits (FOSCSEL[2:0])
BOR	
$\overline{\text{MCLR}}$	COSC[2:0] Control bits (OSCCON[14:12])
WDTO	
SWR	

PIC24FJ256GA705 FAMILY

TABLE 7-3: RESET DELAY TIMES FOR VARIOUS DEVICE RESETS

Reset Type	Clock Source	$\overline{\text{SYSRST}}$ Delay	System Clock Delay	Notes
POR	EC	$\text{TPOR} + \text{TSTARTUP} + \text{TRST}$	—	1, 2, 3
	ECPLL	$\text{TPOR} + \text{TSTARTUP} + \text{TRST}$	TLOCK	1, 2, 3, 5
	XT, HS, SOSC	$\text{TPOR} + \text{TSTARTUP} + \text{TRST}$	TOST	1, 2, 3, 4
	XTPLL, HSPLL	$\text{TPOR} + \text{TSTARTUP} + \text{TRST}$	$\text{TOST} + \text{TLOCK}$	1, 2, 3, 4, 5
	FRC, OSCFDIV	$\text{TPOR} + \text{TSTARTUP} + \text{TRST}$	TFRC	1, 2, 3, 6, 7
	FRCPLL	$\text{TPOR} + \text{TSTARTUP} + \text{TRST}$	$\text{TFRC} + \text{TLOCK}$	1, 2, 3, 5, 6
	LPRC	$\text{TPOR} + \text{TSTARTUP} + \text{TRST}$	TLPRC	1, 2, 3, 6
BOR	EC	$\text{TSTARTUP} + \text{TRST}$	—	2, 3
	ECPLL	$\text{TSTARTUP} + \text{TRST}$	TLOCK	2, 3, 5
	XT, HS, SOSC	$\text{TSTARTUP} + \text{TRST}$	TOST	2, 3, 4
	XTPLL, HSPLL	$\text{TSTARTUP} + \text{TRST}$	$\text{TOST} + \text{TLOCK}$	2, 3, 4, 5
	FRC, OSCFDIV	$\text{TSTARTUP} + \text{TRST}$	TFRC	2, 3, 6, 7
	FRCPLL	$\text{TSTARTUP} + \text{TRST}$	$\text{TFRC} + \text{TLOCK}$	2, 3, 5, 6
	LPRC	$\text{TSTARTUP} + \text{TRST}$	TLPRC	2, 3, 6
MCLR	Any Clock	TRST	—	3
WDT	Any Clock	TRST	—	3
Software	Any clock	TRST	—	3
Illegal Opcode	Any Clock	TRST	—	3
Uninitialized W	Any Clock	TRST	—	3
Trap Conflict	Any Clock	TRST	—	3

Note 1: TPOR = Power-on Reset delay (10 μs nominal).

2: TSTARTUP = TVREG.

3: TRST = Internal State Reset Time (2 μs nominal).

4: TOST = Oscillator Start-up Timer (OST). A 10-bit counter counts 1024 oscillator periods before releasing the oscillator clock to the system.

5: TLOCK = PLL Lock Time.

6: TFRC and TLPRC = RC Oscillator Start-up Times.

7: If Two-Speed Start-up is enabled, regardless of the Primary Oscillator selected, the device starts with FRC so the system clock delay is just TFRC, and in such cases, FRC start-up time is valid; it switches to the Primary Oscillator after its respective clock delay.

PIC24FJ256GA705 FAMILY

7.4.1 POR AND LONG OSCILLATOR START-UP TIMES

The oscillator start-up circuitry and its associated delay timers are not linked to the device Reset delays that occur at power-up. Some crystal circuits (especially low-frequency crystals) will have a relatively long start-up time. Therefore, one or more of the following conditions is possible after $\overline{\text{SYSRST}}$ is released:

- The oscillator circuit has not begun to oscillate.
- The Oscillator Start-up Timer has not expired (if a crystal oscillator is used).
- The PLL has not achieved a lock (if PLL is used).

The device will not begin to execute code until a valid clock source has been released to the system. Therefore, the oscillator and PLL start-up delays must be considered when the Reset delay time must be known.

7.4.2 FAIL-SAFE CLOCK MONITOR (FSCM) AND DEVICE RESETS

If the FSCM is enabled, it will begin to monitor the system clock source when $\overline{\text{SYSRST}}$ is released. If a valid clock source is not available at this time, the device will automatically switch to the FRC Oscillator and the user can switch to the desired crystal oscillator in the Trap Service Routine (TSR).

8.0 INTERRUPT CONTROLLER

Note 1: This data sheet summarizes the features of the PIC24FJ256GA705 family of devices. It is not intended to be a comprehensive reference source. To complement the information in this data sheet, refer to “**Interrupts**” (www.microchip.com/DS70000600) in the “*dsPIC33/PIC24 Family Reference Manual*”. The information in this data sheet supersedes the information in the FRM.

2: Some registers and associated bits described in this section may not be available on all devices. Refer to **Section 4.0 “Memory Organization”** in this data sheet for device-specific register and bit information.

The PIC24FJ256GA705 family interrupt controller reduces the numerous peripheral interrupt request signals to a single interrupt request signal to the PIC24FJ256GA705 family CPU.

The interrupt controller has the following features:

- Up to Eight Processor Exceptions and Software Traps
- Seven User-Selectable Priority Levels
- Interrupt Vector Table (IVT) with a Unique Vector for Each Interrupt or Exception Source
- Fixed Priority within a Specified User Priority Level
- Fixed Interrupt Entry and Return Latencies

8.1 Interrupt Vector Table

The PIC24FJ256GA705 family Interrupt Vector Table (IVT), shown in [Figure 8-1](#), resides in program memory starting at location, 000004h. The IVT contains six non-maskable trap vectors and up to 118 sources of interrupt. In general, each interrupt source has its own vector. Each interrupt vector contains a 24-bit wide address. The value programmed into each interrupt vector location is the starting address of the associated Interrupt Service Routine (ISR).

Interrupt vectors are prioritized in terms of their natural priority. This priority is linked to their position in the vector table. Lower addresses generally have a higher natural priority. For example, the interrupt associated with Vector 0 takes priority over interrupts at any other vector address.

8.1.1 ALTERNATE INTERRUPT VECTOR TABLE

The Alternate Interrupt Vector Table (AIVT) is located after the IVT, as shown in [Figure 8-1](#). The AIVTEN (INTCON2[8]) control bit provides access to the AIVT. If the AIVTEN bit is set, all interrupt and exception processes will use the alternate vectors instead of the default vectors. The alternate vectors are organized in the same manner as the default vectors.

The AIVT supports emulation and debugging efforts by providing a means to switch between an application, and a support environment, without requiring the interrupt vectors to be reprogrammed. This feature also enables switching between applications for evaluation of different software algorithms at run time. If the AIVT is not needed, the AIVT should be programmed with the same addresses used in the IVT.

8.2 Reset Sequence

A device Reset is not a true exception because the interrupt controller is not involved in the Reset process. The PIC24FJ256GA705 family devices clear their registers in response to a Reset, which forces the PC to zero. The device then begins program execution at location, 0x000000. A `GOTO` instruction at the Reset address can redirect program execution to the appropriate start-up routine.

Note: Any unimplemented or unused vector locations in the IVT should be programmed with the address of a default interrupt handler routine that contains a `RESET` instruction.

PIC24FJ256GA705 FAMILY

FIGURE 8-1: PIC24F INTERRUPT VECTOR TABLES

Interrupt Vector Table (IVT) ⁽¹⁾		Alternate Interrupt Vector Table (AIVT) ^(1,2)		
↓ Decreasing Natural Order Priority	Reset – GOTO Instruction	000000h	Reserved	BOA+00h
	Reset – GOTO Address	000002h	Reserved	BOA+02h
	Oscillator Fail Trap Vector	000004h	Oscillator Fail Trap Vector	BOA+04h
	Address Error Trap Vector		Address Error Trap Vector	
	General Hard Trap Vector		General Hard Trap Vector	
	Stack Error Trap Vector		Stack Error Trap Vector	
	Math Error Trap Vector		Math Error Trap Vector	
	Reserved		Reserved	
	General Soft Trap Vector		General Soft Trap Vector	
	Reserved		Reserved	
	Interrupt Vector 0	000014h	Interrupt Vector 0	BOA+14h
	Interrupt Vector 1		Interrupt Vector 1	
	—		—	
	—		—	
	Interrupt Vector 52	00007Ch	Interrupt Vector 52	BOA+7Ch
	Interrupt Vector 53	00007Eh	Interrupt Vector 53	BOA+7Eh
	Interrupt Vector 54	000080h	Interrupt Vector 54	BOA+80h
—		—		
—		—		
Interrupt Vector 116	0000FCh	Interrupt Vector 116	BOA+FEh	
Interrupt Vector 117	0000FEh	Interrupt Vector 117 (Start of Code)	(BOA+100h)	

Legend: BOA: Base Offset Address for AIVT, which is the starting address of the last page of the Boot Segment. All addresses are in hexadecimal.

Note 1: See [Table 8-2](#) for the interrupt vector list.

Note 2: AIVT is only available when a Boot Segment is implemented.

TABLE 8-1: TRAP VECTOR DETAILS

Trap Description	MPLAB® XC16 ISR Name	Vector #	IVT Address	AIVT Address	Trap Bit Location			
					Generic Flag	Source Flag	Enable	Priority
Oscillator Failure	_OscillatorFail	0	000004h	BOA+04h	INTCON1[1]			15
Address Error	_AddressError	1	000006h	BOA+06h	INTCON1[3]			14
General Hardware Error – ECCBDE	_NVMEError	2	000008h	BOA+08h		INTCON4[1]		13
General Hardware Error – SGHT	_NVMEError	2	000008h	BOA+08h		INTCON4[0]	INTCON2[13]	13
Stack Error	_StackError	3	00000Ah	BOA+0Ah	INTCON1[3]			12
Math Error – DIV0ERR	_MathError	4	00000Ch	BOA+0Ch	INTCON1[3]			11
Reserved	_ReservedTrap5	5	00000Eh	BOA+0Eh				
Reserved	_ReservedTrap6	6	000010h	BOA+10h				
Reserved	_ReservedTrap7	7	000012h	BOA+12h				

Legend: BOA = Base Offset Address for AIVT segment, which is the starting address of the last page of the Boot Segment.

PIC24FJ256GA705 FAMILY

TABLE 8-2: INTERRUPT VECTOR DETAILS

Interrupt Description	MPLAB® XC16 ISR Name	Vector #	IRQ #	IVT Address	Interrupt Bit Location		
					Flag	Enable	Priority
Highest Natural Order Priority							
External Interrupt 0	_INT0Interrupt	8	0	000014h	IFS0[0]	IEC0[0]	IPC0[2:0]
Input Capture 1	_IC1Interrupt	9	1	000016h	IFS0[1]	IEC0[1]	IPC0[6:4]
Output Compare 1	_OC1Interrupt	10	2	000018h	IFS0[2]	IEC0[2]	IPC0[10:8]
Timer1	_T1Interrupt	11	3	00001Ah	IFS0[3]	IEC0[3]	IPC0[14:12]
Direct Memory Access 0	_DMA0Interrupt	12	4	00001Ch	IFS0[4]	IEC0[4]	IPC1[2:0]
Input Capture 2	_IC2Interrupt	13	5	00001Eh	IFS0[5]	IEC0[5]	IPC1[6:4]
Output Compare 2	_OC2Interrupt	14	6	000020h	IFS0[6]	IEC0[6]	IPC1[10:8]
Timer2	_T2Interrupt	15	7	000022h	IFS0[7]	IEC0[7]	IPC1[14:12]
Timer3	_T3Interrupt	16	8	000024h	IFS0[8]	IEC0[8]	IPC2[2:0]
SPI1 General	_SPI1Interrupt	17	9	000026h	IFS0[9]	IEC0[9]	IPC2[6:4]
SPI1 Transfer Done	_SPI1TXInterrupt	18	10	000028h	IFS0[10]	IEC0[10]	IPC2[10:8]
UART1 Receiver	_U1RXInterrupt	19	11	00002Ah	IFS0[11]	IEC0[11]	IPC2[14:12]
UART1 Transmitter	_U1TXInterrupt	20	12	00002Ch	IFS0[12]	IEC0[12]	IPC3[2:0]
A/D Converter 1	_ADC1Interrupt	21	13	00002Eh	IFS0[13]	IEC0[13]	IPC3[6:4]
Direct Memory Access 1	_DMA1Interrupt	22	14	000030h	IFS0[14]	IEC0[14]	IPC3[10:8]
NVM Program/Erase Complete	_NVMInterrupt	23	15	000032h	IFS0[15]	IEC0[15]	IPC3[14:12]
I2C1 Slave Events	_SI2C1Interrupt	24	16	000034h	IFS1[0]	IEC1[0]	IPC4[2:0]
I2C1 Master Events	_MI2C1Interrupt	25	17	000036h	IFS1[1]	IEC1[1]	IPC4[6:4]
Comparator	_CompInterrupt	26	18	000038h	IFS1[2]	IEC1[2]	IPC4[10:8]
Interrupt-on-Change Interrupt	_IOCInterrupt	27	19	00003Ah	IFS1[3]	IEC1[3]	IPC4[14:12]
External Interrupt 1	_INT1Interrupt	28	20	00003Ch	IFS1[4]	IEC1[4]	IPC5[2:0]
Reserved	Reserved	29	21	—	—	—	—
Reserved	Reserved	30	22	—	—	—	—
Reserved	Reserved	31	23	—	—	—	—
Direct Memory Access 2	_DMA2Interrupt	32	24	000044h	IFS1[8]	IEC1[8]	IPC6[2:0]
Output Compare 3	_OC3Interrupt	33	25	000046h	IFS1[9]	IEC1[9]	IPC6[6:4]
Reserved	Reserved	34	26	—	—	—	—
Reserved	Reserved	35	27	—	—	—	—
Reserved	Reserved	36	28	—	—	—	—
External Interrupt 2	_INT2Interrupt	37	29	00004Eh	IFS1[13]	IEC1[13]	IPC7[6:4]
UART2 Receiver	_U2RXInterrupt	38	30	000050h	IFS1[14]	IEC1[14]	IPC7[10:8]
UART2 Transmitter	_U2TXInterrupt	39	31	000052h	IFS1[15]	IEC1[15]	IPC7[14:12]
SPI2 General	_SPI2Interrupt	40	32	000054h	IFS2[0]	IEC2[0]	IPC8[2:0]
SPI2 Transfer Done	_SPI2TXInterrupt	41	33	000056h	IFS2[1]	IEC2[1]	IPC8[6:4]
Reserved	Reserved	42	34	—	—	—	—
Reserved	Reserved	43	35	—	—	—	—
Direct Memory Access 3	_DMA3Interrupt	44	36	00005Ch	IFS2[4]	IEC2[4]	IPC9[2:0]
Input Capture 3	_IC3Interrupt	45	37	00005Eh	IFS2[5]	IEC2[5]	IPC9[6:4]
Reserved	Reserved	46	38	—	—	—	—
Reserved	Reserved	47	39	—	—	—	—

PIC24FJ256GA705 FAMILY

TABLE 8-2: INTERRUPT VECTOR DETAILS (CONTINUED)

Interrupt Description	MPLAB® XC16 ISR Name	Vector #	IRQ #	IVT Address	Interrupt Bit Location		
					Flag	Enable	Priority
Reserved	Reserved	48	40	—	—	—	—
Capture/Compare Timer3	_CCT3Interrupt	51	43	00006Ah	IFS2[11]	IEC2[11]	IPC10[14:12]
Capture/Compare Timer4	_CCT4Interrupt	52	44	00006Ch	IFS2[12]	IEC2[12]	IPC11[2:0]
Parallel Master Port	_PMPInterrupt	53	45	00006Eh	IFS2[13]	IEC2[13]	IPC11[6:4]
Direct Memory Access 4	_DMA4Interrupt	54	46	000070h	IFS2[14]	IEC2[14]	IPC11[10:8]
Reserved	Reserved	55	47	—	—	—	—
Reserved	Reserved	56	48	—	—	—	—
I2C2 Slave Events	_SI2C2Interrupt	57	49	000076h	IFS3[1]	IEC3[1]	IPC12[6:4]
I2C2 Master Events	_MI2C2Interrupt	58	50	000078h	IFS3[2]	IEC3[2]	IPC12[10:8]
Reserved	Reserved	59	51	—	—	—	—
Reserved	Reserved	60	52	—	—	—	—
External Interrupt 3	_INT3Interrupt	61	53	00007Eh	IFS3[5]	IEC3[5]	IPC13[6:4]
External Interrupt 4	_INT4Interrupt	62	54	000080h	IFS3[6]	IEC3[6]	IPC13[10:8]
Reserved	Reserved	63	55	—	—	—	—
Reserved	Reserved	64	56	—	—	—	—
Reserved	Reserved	65	57	—	—	—	—
SPI1 Receive Done	_SPI1RXInterrupt	66	58	000088h	IFS3[10]	IEC3[10]	IPC14[10:8]
SPI2 Receive Done	_SPI2RXInterrupt	67	59	00008Ah	IFS3[11]	IEC3[11]	IPC14[14:12]
SPI3 Receive Done	_SPI3RXInterrupt	68	60	00008Ch	IFS3[12]	IEC3[12]	IPC15[2:0]
Direct Memory Access 5	_DMA5Interrupt	69	61	00008Eh	IFS3[13]	IEC3[13]	IPC15[6:4]
Real-Time Clock and Calendar	_RTCCInterrupt	70	62	000090h	IFS3[14]	IEC3[14]	IPC15[10:8]
Capture/Compare 1	_CCP1Interrupt	71	63	000092h	IFS3[15]	IEC3[15]	IPC15[14:12]
Capture/Compare 2	_CCP2Interrupt	72	64	000094h	IFS4[0]	IEC4[0]	IPC16[2:0]
UART1 Error	_U1ErrInterrupt	73	65	000096h	IFS4[1]	IEC4[1]	IPC16[6:4]
UART2 Error	_U2ErrInterrupt	74	66	000098h	IFS4[2]	IEC4[2]	IPC16[10:8]
Cyclic Redundancy Check	_CRCInterrupt	75	67	00009Ah	IFS4[3]	IEC4[3]	IPC16[14:12]
Reserved	Reserved	76	68	—	—	—	—
Reserved	Reserved	77	69	—	—	—	—
Reserved	Reserved	78	70	—	—	—	—
Reserved	Reserved	79	71	—	—	—	—
HLVD – High/Low-Voltage Detect	_LVDInterrupt	80	72	0000A4h	IFS4[8]	IEC4[8]	IPC18[2:0]
Reserved	Reserved	81	73	—	—	—	—
Reserved	Reserved	82	74	—	—	—	—
Reserved	Reserved	83	75	—	—	—	—
Reserved	Reserved	84	76	—	—	—	—
CTMU Interrupt	_CTMUInterrupt	85	77	0000AEh	IFS4[13]	IEC4[13]	IPC19[6:4]
Reserved	Reserved	86	78	—	—	—	—
Reserved	Reserved	87	79	—	—	—	—
Reserved	Reserved	88	80	—	—	—	—
Reserved	Reserved	89	81	—	—	—	—

PIC24FJ256GA705 FAMILY

TABLE 8-2: INTERRUPT VECTOR DETAILS (CONTINUED)

Interrupt Description	MPLAB® XC16 ISR Name	Vector #	IRQ #	IVT Address	Interrupt Bit Location		
					Flag	Enable	Priority
Reserved	Reserved	90	82	—	—	—	—
Reserved	Reserved	91	83	—	—	—	—
I2C1 Bus Collision	_I2C1BCInterrupt	92	84	0000BCh	IFS5[4]	IEC5[4]	IPC21[2:0]
I2C2 Bus Collision	_I2C2BCInterrupt	93	85	0000BEh	IFS5[5]	IEC5[5]	IPC21[6:4]
Reserved	Reserved	94	86	—	—	—	—
Reserved	Reserved	95	87	—	—	—	—
Reserved	Reserved	96	88	—	—	—	—
Reserved	Reserved	97	89	—	—	—	—
SPI3 General	_SPI3Interrupt	98	90	0000C8h	IFS5[10]	IEC5[10]	IPC22[10:8]
SPI3 Transfer Done	_SPI3TXInterrupt	99	91	0000CAh	IFS5[11]	IEC5[11]	IPC22[14:12]
Reserved	Reserved	100	92	92	—	—	—
Reserved	Reserved	101	93	93	—	—	—
Capture/Compare 3	_CCP3Interrupt	102	94	0000D0h	IFS5[14]	IEC5[14]	IPC23[10:8]
Capture/Compare 4	_CCP4Interrupt	103	95	0000D2h	IFS5[15]	IEC5[15]	IPC23[14:12]
Configurable Logic Cell 1	_CLC1Interrupt	104	96	0000D4h	IFS6[0]	IEC6[0]	IPC24[2:0]
Configurable Logic Cell 2	_CLC2Interrupt	105	97	0000D6h	IFS6[1]	IEC6[1]	IPC24[6:4]
Reserved	Reserved	106	98	—	—	—	—
Reserved	Reserved	107	99	—	—	—	—
Reserved	Reserved	108	100	—	—	—	—
Capture/Compare Timer1	_CCT1Interrupt	109	101	0000DEh	IFS6[5]	IEC6[5]	IPC25[6:4]
Capture/Compare Timer2	_CCT2Interrupt	110	102	0000E0h	IFS6[6]	IEC6[6]	IPC25[10:8]
Reserved	Reserved	111	103	—	—	—	—
Reserved	Reserved	112	104	—	—	—	—
Reserved	Reserved	113	105	—	—	—	—
FRC Self-Tuning Interrupt	_FSTInterrupt	114	106	0000E8h	IFS6[10]	IEC6[10]	IPC26[10:8]
Reserved	Reserved	115	107	—	—	—	—
ECC Single Bit Error	_ECCInterrupt	116	108	0000ECh	IFS6[12]	IEC6[12]	IPC27[2:0]
Reserved	Reserved	117	109	—	—	—	—
Real-Time Clock Timestamp	_RTCCTSInterrupt	118	110	0000F0h	IFS6[14]	IEC6[14]	IPC27[10:8]
Reserved	Reserved	119	111	—	—	—	—
Reserved	Reserved	120	112	—	—	—	—
Reserved	Reserved	121	113	—	—	—	—
Reserved	Reserved	122	114	—	—	—	—
Reserved	Reserved	123	115	—	—	—	—
Reserved	Reserved	124	116	—	—	—	—
JTAG	_JTAGInterrupt	125	117	0000FEh	IFS7[5]	IEC7[5]	IPC29[6:4]

PIC24FJ256GA705 FAMILY

8.3 Interrupt Resources

Many useful resources are provided on the main product page of the Microchip website for the devices listed in this data sheet. This product page, which can be accessed using this [link](#), contains the latest updates and additional information.

Note: In the event you are not able to access the product page using the link above, enter this URL in your browser:
<http://www.microchip.com/wwwproducts/Devices.aspx?dDocName=en555464>

8.3.1 KEY RESOURCES

- “**Interrupts**” (www.microchip.com/DS70000600) in the “*dsPIC33/PIC24 Family Reference Manual*”
- Code Samples
- Application Notes
- Software Libraries
- Webinars
- All Related “*dsPIC33/PIC24 Family Reference Manual*” Sections
- Development Tools

8.4 Interrupt Control and Status Registers

PIC24FJ256GA705 family devices implement the following registers for the interrupt controller:

- INTCON1
- INTCON2
- INTCON4
- IFS0 through IFS7
- IEC0 through IEC7
- IPC0 through ICP29
- INTTREG

8.4.1 INTCON1-INTCON4

Global interrupt control functions are controlled from INTCON1 and INTCON2. INTCON1 contains the Interrupt Nesting Disable (NSTDIS) bit, as well as the control and status flags for the processor trap sources.

The INTCON2 register controls global interrupt generation, the external interrupt request signal behavior and the use of the Alternate Interrupt Vector Table (AIVT).

The INTCON4 register contains the Software-Generated Hard Trap bit (SGHT) and ECC Double-Bit Error (ECCDBE) trap.

8.4.2 IFSx

The IFSx registers maintain all of the interrupt request flags. Each source of interrupt has a status bit, which is set by the respective peripherals or external signal, and is cleared via software.

8.4.3 IECx

The IECx registers maintain all of the interrupt enable bits. These control bits are used to individually enable interrupts from the peripherals or external signals.

8.4.4 IPCx

The IPCx registers are used to set the Interrupt Priority Level (IPL) for each source of interrupt. Each user interrupt source can be assigned to one of eight priority levels.

8.4.5 INTTREG

The INTTREG register contains the associated interrupt vector number and the new CPU Interrupt Priority Level, which are latched into the Vector Number bits (VECNUM[7:0]) and Interrupt Priority Level bits (ILR[3:0]) fields in the INTTREG register. The new Interrupt Priority Level is the priority of the pending interrupt.

The interrupt sources are assigned to the IFSx, IECx and IPCx registers in the same sequence as they are listed in [Table 8-2](#). For example, the INT0 (External Interrupt 0) is shown as having Vector Number 8 and a natural order priority of 0. Thus, the INTOIF bit is found in IFS0[0], the INTOIE bit in IEC0[0] and the INTOIPx bits in the first position of IPC0 (IPC0[2:0]).

8.4.6 STATUS/CONTROL REGISTERS

Although these registers are not specifically part of the interrupt control hardware, two of the CPU Control registers contain bits that control interrupt functionality. For more information on these registers, refer to “**CPU with Extended Data Space (EDS)**” (www.microchip.com/DS39732) in the “*dsPIC33/PIC24 Family Reference Manual*”.

- The CPU STATUS Register, SR, contains the IPL[2:0] bits (SR[7:5]). These bits indicate the current CPU Interrupt Priority Level. The user software can change the current CPU Interrupt Priority Level by writing to the IPLx bits.
- The CORCON register contains the IPL3 bit, which together with the IPL[2:0] bits, also indicates the current CPU Interrupt Priority Level. IPL3 is a read-only bit so that trap events cannot be masked by the user software.

All Interrupt registers are described in [Register 8-3](#) through [Register 8-6](#) in the following pages.

PIC24FJ256GA705 FAMILY

REGISTER 8-1: SR: ALU STATUS REGISTER⁽¹⁾

U-0	U-0	U-0	U-0	U-0	U-0	U-0	R/W-0
—	—	—	—	—	—	—	DC
bit 15							bit 8

R/W-0 ⁽³⁾	R/W-0 ⁽³⁾	R/W-0 ⁽³⁾	R-0	R/W-0	R/W-0	R/W-0	R/W-0
IPL2 ⁽²⁾	IPL1 ⁽²⁾	IPL0 ⁽²⁾	RA	N	OV	Z	C
bit 7							bit 0

Legend:

R = Readable bit

W = Writable bit

U = Unimplemented bit, read as '0'

-n = Value at POR

'1' = Bit is set

'0' = Bit is cleared

x = Bit is unknown

bit 7-5 **IPL[2:0]: CPU Interrupt Priority Level Status bits^(2,3)**

111 = CPU Interrupt Priority Level is 7 (15); user interrupts are disabled

110 = CPU Interrupt Priority Level is 6 (14)

101 = CPU Interrupt Priority Level is 5 (13)

100 = CPU Interrupt Priority Level is 4 (12)

011 = CPU Interrupt Priority Level is 3 (11)

010 = CPU Interrupt Priority Level is 2 (10)

001 = CPU Interrupt Priority Level is 1 (9)

000 = CPU Interrupt Priority Level is 0 (8)

Note 1: For complete register details, see [Register 3-1](#).

2: The IPL[2:0] Status bits are concatenated with the IPL3 Status bit (CORCON[3]) to form the CPU Interrupt Priority Level (IPL). The value in parentheses indicates the IPL when IPL3 = 1. User interrupts are disabled when IPL3 = 1.

3: The IPL[2:0] Status bits are read-only when the NSTDIS bit (INTCON1[15]) = 1.

PIC24FJ256GA705 FAMILY

REGISTER 8-2: CORCON: CPU CORE CONTROL REGISTER⁽¹⁾

U-0	U-0	U-0	U-0	U-0	U-0	U-0	U-0
—	—	—	—	—	—	—	—
bit 15							bit 8

U-0	U-0	U-0	U-0	R/C-0	R/W-1	U-0	U-0
—	—	—	—	IPL3 ⁽²⁾	PSV	—	—
bit 7							bit 0

Legend:	C = Clearable bit
R = Readable bit	W = Writable bit
-n = Value at POR	'1' = Bit is set
	U = Unimplemented bit, read as '0'
	'0' = Bit is cleared
	x = Bit is unknown

- bit 15-4 **Unimplemented:** Read as '0'
- bit 3 **IPL3:** CPU Interrupt Priority Level Status bit⁽²⁾
 - 1 = CPU Interrupt Priority Level is greater than 7
 - 0 = CPU Interrupt Priority Level is 7 or less
- bit 2 **PSV:** Not used as part of the interrupt module
- bit 1-0 **Unimplemented:** Read as '0'

- Note 1:** For complete register details, see [Register 3-2](#).
- 2:** The IPL[2:0] Status bits are concatenated with the IPL3 Status bit (CORCON[3]) to form the CPU Interrupt Priority Level (IPL). The value in parentheses indicates the IPL when IPL3 = 1. User interrupts are disabled when IPL3 = 1.

PIC24FJ256GA705 FAMILY

REGISTER 8-3: INTCON1: INTERRUPT CONTROL REGISTER 1

R/W-0	U-0	U-0	U-0	U-0	U-0	U-0	U-0
NSTDIS	—	—	—	—	—	—	—
bit 15							bit 8

U-0	U-0	U-0	R/W-0	R/W-0	R/W-0	R/W-0	U-0
—	—	—	MATHERR	ADDRERR	STKERR	OSCFAIL	—
bit 7							bit 0

Legend:

R = Readable bit

W = Writable bit

U = Unimplemented bit, read as '0'

-n = Value at POR

'1' = Bit is set

'0' = Bit is cleared

x = Bit is unknown

- bit 15 **NSTDIS:** Interrupt Nesting Disable bit
 1 = Interrupt nesting is disabled
 0 = Interrupt nesting is enabled
- bit 14-5 **Unimplemented:** Read as '0'
- bit 4 **MATHERR:** Math Error Status bit
 1 = Math error trap has occurred
 0 = Math error trap has not occurred
- bit 3 **ADDRERR:** Address Error Trap Status bit
 1 = Address error trap has occurred
 0 = Address error trap has not occurred
- bit 2 **STKERR:** Stack Error Trap Status bit
 1 = Stack error trap has occurred
 0 = Stack error trap has not occurred
- bit 1 **OSCFAIL:** Oscillator Failure Trap Status bit
 1 = Oscillator failure trap has occurred
 0 = Oscillator failure trap has not occurred
- bit 0 **Unimplemented:** Read as '0'

PIC24FJ256GA705 FAMILY

REGISTER 8-4: INTCON2: INTERRUPT CONTROL REGISTER 2

R/W-1	R-0	R/W-0	U-0	U-0	U-0	U-0	R/W-0
GIE	DISI	SWTRAP	—	—	—	—	AIVTEN
bit 15							bit 8

U-0	U-0	U-0	R/W-0	R/W-0	R/W-0	R/W-0	R/W-0
—	—	—	INT4EP	INT3EP	INT2EP	INT1EP	INT0EP
bit 7							bit 0

Legend:

R = Readable bit W = Writable bit U = Unimplemented bit, read as '0'
 -n = Value at POR '1' = Bit is set '0' = Bit is cleared x = Bit is unknown

- bit 15 **GIE:** Global Interrupt Enable bit
 1 = Interrupts and associated interrupt enable bits are enabled
 0 = Interrupts are disabled, but traps are still enabled
- bit 14 **DISI:** DISI Instruction Status bit
 1 = DISI instruction is active
 0 = DISI instruction is not active
- bit 13 **SWTRAP:** Software Trap Status bit
 1 = Software trap is enabled
 0 = Software trap is disabled
- bit 12-9 **Unimplemented:** Read as '0'
- bit 8 **AIVTEN:** Alternate Interrupt Vector Table Enable bit
 1 = Uses Alternate Interrupt Vector Table (if enabled in Configuration bits)
 0 = Uses standard Interrupt Vector Table (default)
- bit 7-5 **Unimplemented:** Read as '0'
- bit 4 **INT4EP:** External Interrupt 4 Edge Detect Polarity Select bit
 1 = Interrupt on negative edge
 0 = Interrupt on positive edge
- bit 3 **INT3EP:** External Interrupt 3 Edge Detect Polarity Select bit
 1 = Interrupt on negative edge
 0 = Interrupt on positive edge
- bit 2 **INT2EP:** External Interrupt 2 Edge Detect Polarity Select bit
 1 = Interrupt on negative edge
 0 = Interrupt on positive edge
- bit 1 **INT1EP:** External Interrupt 1 Edge Detect Polarity Select bit
 1 = Interrupt on negative edge
 0 = Interrupt on positive edge
- bit 0 **INT0EP:** External Interrupt 0 Edge Detect Polarity Select bit
 1 = Interrupt on negative edge
 0 = Interrupt on positive edge

PIC24FJ256GA705 FAMILY

REGISTER 8-5: INTCON4: INTERRUPT CONTROL REGISTER 4

U-0	U-0	U-0	U-0	U-0	U-0	U-0	U-0
—	—	—	—	—	—	—	—
bit 15							bit 8

U-0	U-0	U-0	U-0	U-0	U-0	R/C-0	R/C-0
—	—	—	—	—	—	ECCDBE	SGHT
bit 7						bit 0	

Legend:	C = Clearable bit		
R = Readable bit	W = Writable bit	U = Unimplemented bit, read as '0'	
-n = Value at POR	'1' = Bit is set	'0' = Bit is cleared	x = Bit is unknown

bit 15-2 **Unimplemented:** Read as '0'

bit 1 **ECCDBE:** ECC Double-Bit Error Trap bit
 1 = ECC Double-Bit Error trap has occurred
 0 = ECC Double-Bit Error trap has not occurred

bit 0 **SGHT:** Software-Generated Hard Trap Status bit
 1 = Software-generated hard trap has occurred
 0 = Software-generated hard trap has not occurred

PIC24FJ256GA705 FAMILY

REGISTER 8-6: INTTREG: INTERRUPT CONTROL AND STATUS REGISTER

R-0	U-0	R/W-0	U-0	R-0	R-0	R-0	R-0
CPUIRQ	—	VHOLD	—	ILR3	ILR2	ILR1	ILR0
bit 15							bit 8

R-0	R-0	R-0	R-0	R-0	R-0	R-0	R-0
VECNUM[7:0]							
bit 7							bit 0

Legend:

R = Readable bit	W = Writable bit	U = Unimplemented bit, read as '0'
-n = Value at POR	'1' = Bit is set	'0' = Bit is cleared x = Bit is unknown

- bit 15 **CPUIRQ:** Interrupt Request from Interrupt Controller to CPU bit
 1 = An interrupt request has occurred but has not yet been Acknowledged by the CPU; this happens when the CPU priority is higher than the interrupt priority
 0 = No interrupt request is unacknowledged
- bit 14 **Unimplemented:** Read as '0'
- bit 13 **VHOLD:** Vector Number Capture Configuration bit
 1 = The VECNUMx bits contain the value of the highest priority pending interrupt
 0 = The VECNUMx bits contain the value of the last Acknowledged interrupt (i.e., the last interrupt that has occurred with higher priority than the CPU, even if other interrupts are pending)
- bit 12 **Unimplemented:** Read as '0'
- bit 11-8 **ILR[3:0]:** New CPU Interrupt Priority Level bits
 1111 = CPU Interrupt Priority Level is 15
 •
 •
 •
 0001 = CPU Interrupt Priority Level is 1
 0000 = CPU Interrupt Priority Level is 0
- bit 7-0 **VECNUM[7:0]:** Vector Number of Pending Interrupt bits
 11111111 = 255, Reserved; do not use
 •
 •
 •
 00001001 = 9, IC1 – Input Capture 1
 00001000 = 8, INT0 – External Interrupt 0
 00000111 = 7, Reserved; do not use
 00000110 = 6, Generic soft error trap
 00000101 = 5, Reserved; do not use
 00000100 = 4, Math error trap
 00000011 = 3, Stack error trap
 00000010 = 2, Generic hard trap
 00000001 = 1, Address error trap
 00000000 = 0, Oscillator fail trap

9.0 OSCILLATOR CONFIGURATION

Note: This data sheet summarizes the features of this group of PIC24F devices. It is not intended to be a comprehensive reference source. For more information, refer to “Oscillator” (www.microchip.com/DS39700) in the “dsPIC33/PIC24 Family Reference Manual”. The information in this data sheet supersedes the information in the FRM.

- Software-Controllable Postscaler for Selective Clocking of CPU for System Power Savings
- A Fail-Safe Clock Monitor (FSCM) that Detects Clock Failure and Permits Safe Application Recovery or Shutdown
- A Separate and Independently Configurable System Clock Output for Synchronizing External Hardware

A simplified diagram of the oscillator system is shown in Figure 9-1.

The oscillator system for the PIC24FJ256GA705 family devices has the following features:

- An On-Chip PLL Block to provide a Range of Frequency Options for the System Clock
- Software-Controllable Switching between Various Clock Sources

FIGURE 9-1: PIC24FJ256GA705 FAMILY CLOCK DIAGRAM

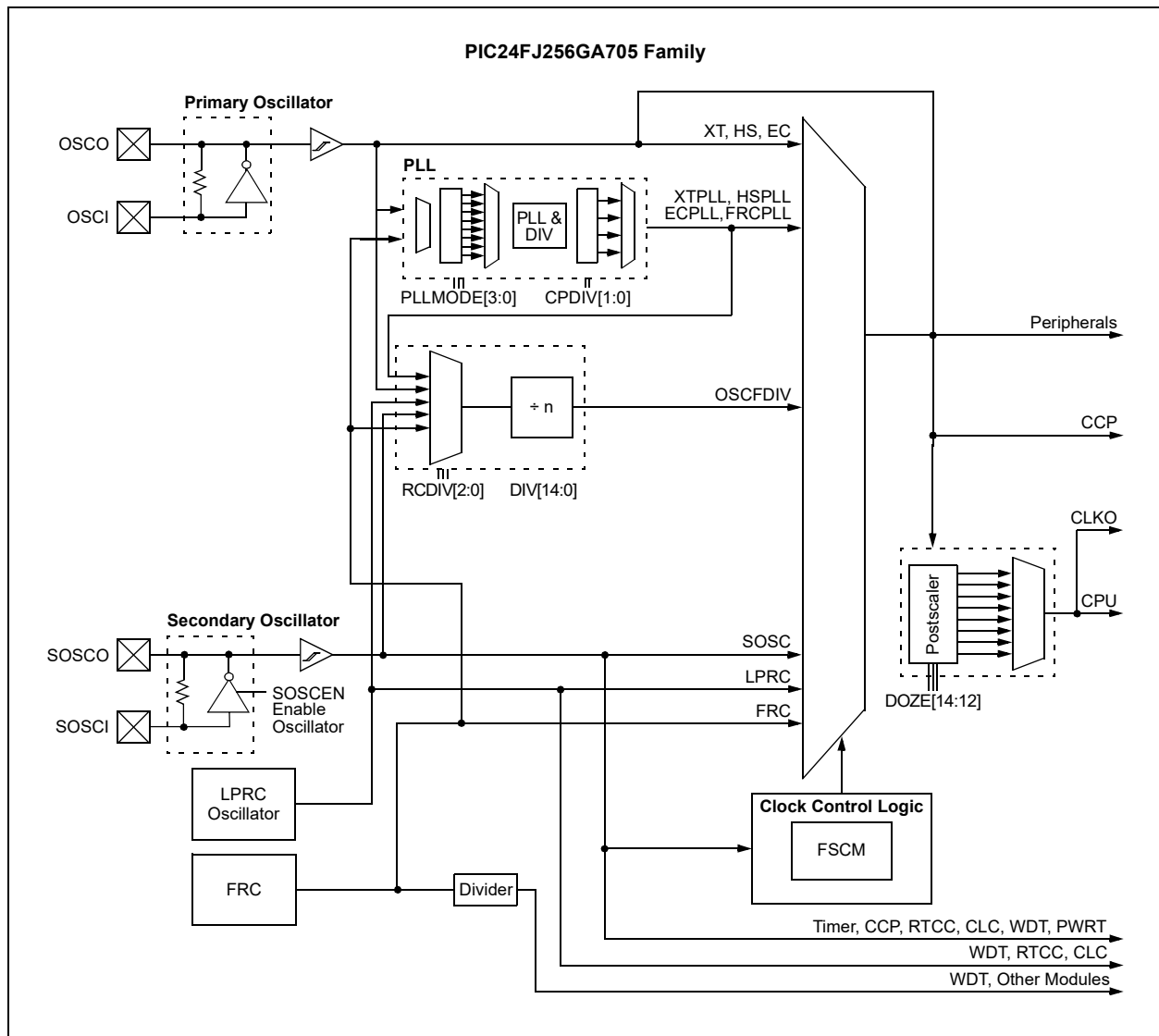

PIC24FJ256GA705 FAMILY

9.1 CPU Clocking Scheme

The system clock source can be provided by one of four sources:

- Primary Oscillator (POSC) on the OSC1 and OSC0 pins
- Secondary Oscillator (SOSC) on the SOSCI and SOSCO pins
- Fast Internal RC (FRC) Oscillator
- Low-Power Internal RC (LPRC) Oscillator

The Primary Oscillator and FRC sources have the option of using the internal PLL block, which can generate a 4x, 6x or 8x PLL clock. If the PLL is used, the PLL clocks can then be postscaled, if necessary, and used as the system clock. Refer to [Section 9.5 “Oscillator Modes”](#) for additional information. The internal FRC provides an 8 MHz clock source.

Each clock source (PRIPLL, FRCPLL, PRI, FRC, LPRC and SOSC) can be used as an input to an additional divider, which can then be used to produce a divided clock source for use as a system clock (OSCFDIV).

The selected clock source generates the processor and peripheral clock sources. The processor clock source is divided by two to produce the internal instruction cycle clock, Fcy. In this document, the instruction cycle clock is also denoted by Fosc/2. The internal instruction cycle clock, Fosc/2, can be provided on the OSC0 I/O pin for some operating modes of the Primary Oscillator.

9.2 Initial Configuration on POR

The oscillator source (and operating mode) that is used at a device Power-on Reset event is selected using Configuration bit settings. The Oscillator Configuration bit settings are located in the Configuration registers in the program memory (refer to [Section 29.1 “Configuration Bits”](#) for further details). The Primary Oscillator Configuration bits, POSCMD[1:0] (FOSC[1:0]), and the Oscillator Select Configuration bits, FNOSC[2:0] (FOSCSEL[2:0]), select the oscillator source that is used at a Power-on Reset. The OSCFDIV clock source is the default (unprogrammed) selection; the default input source to the OSCFDIV divider is the FRC clock source. Other oscillators may be chosen by programming these bit locations.

The Configuration bits allow users to choose between the various Clock modes shown in [Table 9-1](#).

9.2.1 CLOCK SWITCHING MODE CONFIGURATION BITS

The FCKSM[1:0] Configuration bits (FOSC[7:6]) are used to jointly configure device clock switching and the Fail-Safe Clock Monitor (FSCM). Clock switching is enabled only when FCKSM1 is programmed ('0'). The FSCM is enabled only when FCKSM[1:0] are both programmed ('00').

TABLE 9-1: CONFIGURATION BIT VALUES FOR CLOCK SELECTION

Oscillator Mode	Oscillator Source	POSCMD[1:0]	FNOSC[2:0]	Notes
Oscillator with Frequency Division (OSCFDIV)	Internal/External	11	111	1, 2, 3
Low-Power RC Oscillator (LPRC)	Internal	11	101	3
Secondary (Timer1) Oscillator (SOSC)	Secondary	11	100	3
Primary Oscillator (XT) with PLL Module (XTPLL)	Primary	01	011	
Primary Oscillator (EC) with PLL Module (ECPLL)	Primary	00	011	
Primary Oscillator (HS)	Primary	10	010	
Primary Oscillator (XT)	Primary	01	010	
Primary Oscillator (EC)	Primary	00	010	
Fast RC Oscillator with PLL Module (FRCPLL)	Internal	11	001	3
Fast RC Oscillator (FRC)	Internal	11	000	3

Note 1: The input oscillator to the OSCFDIV Clock mode is determined by the RCDIV[2:0] (CLKDIV[10:8]) bits. At POR, the default value selects the FRC module.

2: This is the default Oscillator mode for an unprogrammed (erased) device.

3: OSCO pin function is determined by the OSCIOFCN Configuration bit.

9.3 Control Registers

The operation of the oscillator is controlled by five Special Function Registers:

- OSCCON
- CLKDIV
- OSCTUN
- OSCDIV
- OSCFDIV

The OSCCON register ([Register 9-1](#)) is the main control register for the oscillator. It controls clock source switching and allows the monitoring of clock sources. OSCCON is protected by a write lock to prevent inadvertent clock switches. See [Section 9.4 “Clock Switching Operation”](#) for more information.

The CLKDIV register ([Register 9-2](#)) controls the features associated with Doze mode, as well as the postscalers for the OSCFDIV Clock mode and the PLL module.

The OSCTUN register ([Register 9-3](#)) allows the user to fine-tune the FRC Oscillator over a range of approximately $\pm 1.5\%$.

The OSCDIV and OSCFDIV registers provide control for the system oscillator frequency divider.

PIC24FJ256GA705 FAMILY

REGISTER 9-1: OSCCON: OSCILLATOR CONTROL REGISTER⁽¹⁾

U-0	R-x ⁽²⁾	R-x ⁽²⁾	R-x ⁽²⁾	U-0	R/W-x ⁽²⁾	R/W-x ⁽²⁾	R/W-x ⁽²⁾
—	COSC2	COSC1	COSC0	—	NOSC2	NOSC1	NOSC0
bit 15							bit 8

R/W-0	R/W-0	R-0 ⁽⁴⁾	U-0	R/CO-0	R/W-0	R/W-0	R/W-0
CLKLOCK	IOLOCK ⁽³⁾	LOCK	—	CF	POSCEN	SOSCEN	OSWEN
bit 7							bit 0

Legend:	CO = Clearable Only bit
R = Readable bit	W = Writable bit
-n = Value at POR	'1' = Bit is set
	U = Unimplemented bit, read as '0'
	'0' = Bit is cleared
	x = Bit is unknown

bit 15 **Unimplemented:** Read as '0'

bit 14-12 **COSC[2:0]:** Current Oscillator Selection bits⁽²⁾

111 = Oscillator with Frequency Divider (OSCFDIV)

110 = Reserved

101 = Low-Power RC Oscillator (LPRC)

100 = Secondary Oscillator (SOSC)

011 = Primary Oscillator with PLL module (XTPLL, ECPLL)

010 = Primary Oscillator (XT, HS, EC)

001 = Fast RC Oscillator with PLL module (FRCPLL)

000 = Fast RC Oscillator (FRC)

bit 11 **Unimplemented:** Read as '0'

bit 10-8 **NOSC[2:0]:** New Oscillator Selection bits⁽²⁾

111 = Oscillator with Frequency Divider (OSCFDIV)

110 = Reserved

101 = Low-Power RC Oscillator (LPRC)

100 = Secondary Oscillator (SOSC)

011 = Primary Oscillator with PLL module (XTPLL, ECPLL)

010 = Primary Oscillator (XT, HS, EC)

001 = Fast RC Oscillator with PLL module (FRCPLL)

000 = Fast RC Oscillator (FRC)

bit 7 **CLKLOCK:** Clock Selection Lock Enable bit

If FSCM is Enabled (FCKSM[1:0] = 00):

1 = Clock and PLL selections are locked

0 = Clock and PLL selections are not locked and may be modified by setting the OSWEN bit

If FSCM is Disabled (FCKSM[1:0] = 1x):

Clock and PLL selections are never locked and may be modified by setting the OSWEN bit.

bit 6 **IOLOCK:** I/O Lock Enable bit⁽³⁾

1 = I/O lock is active

0 = I/O lock is not active

bit 5 **LOCK:** PLL Lock Status bit⁽⁴⁾

1 = PLL module is in lock or PLL module start-up timer is satisfied

0 = PLL module is out of lock, PLL start-up timer is running or PLL is disabled

Note 1: OSCCON is protected by a write lock to prevent inadvertent clock switches. See [Section 9.4 “Clock Switching Operation”](#) for more information.

2: Reset values for these bits are determined by the FNOSC_x Configuration bits.

3: The state of the IOLOCK bit can only be changed once an unlocking sequence has been executed. In addition, if the IOL1WAY Configuration bit is '1' once the IOLOCK bit is set, it cannot be cleared.

4: This bit also resets to '0' during any valid clock switch or whenever a non-PLL Clock mode is selected.

REGISTER 9-1: OSCCON: OSCILLATOR CONTROL REGISTER⁽¹⁾ (CONTINUED)

bit 4	Unimplemented: Read as '0'
bit 3	CF: Clock Fail Detect bit 1 = FSCM has detected a clock failure 0 = No clock failure has been detected
bit 2	POSCEN: Primary Oscillator Sleep Enable bit 1 = Primary Oscillator continues to operate during Sleep mode 0 = Primary Oscillator is disabled during Sleep mode
bit 1	SOSCEN: 32 kHz Secondary Oscillator (SOSC) Enable bit 1 = Enables Secondary Oscillator 0 = Disables Secondary Oscillator
bit 0	OSWEN: Oscillator Switch Enable bit 1 = Initiates an oscillator switch to a clock source specified by the NOSC[2:0] bits 0 = Oscillator switch is complete

- Note 1:** OSCCON is protected by a write lock to prevent inadvertent clock switches. See [Section 9.4 “Clock Switching Operation”](#) for more information.
- 2:** Reset values for these bits are determined by the FNOSC_x Configuration bits.
- 3:** The state of the IOLOCK bit can only be changed once an unlocking sequence has been executed. In addition, if the IOL1WAY Configuration bit is '1' once the IOLOCK bit is set, it cannot be cleared.
- 4:** This bit also resets to '0' during any valid clock switch or whenever a non-PLL Clock mode is selected.

PIC24FJ256GA705 FAMILY

REGISTER 9-2: CLKDIV: CLOCK DIVIDER REGISTER

R/W-0	R/W-0	R/W-1	R/W-1	R/W-0	R/W-0	R/W-0	R/W-0
ROI	DOZE2	DOZE1	DOZE0	DOZEN ⁽¹⁾	RCDIV2	RCDIV1	RCDIV0
bit 15							bit 8

R/W-0	R/W-0	R/W-0	U-0	U-0	U-0	U-0	U-0
CPDIV1	CPDIV0	PLLEN	—	—	—	—	—
bit 7							bit 0

Legend:

R = Readable bit W = Writable bit U = Unimplemented bit, read as '0'
 -n = Value at POR '1' = Bit is set '0' = Bit is cleared x = Bit is unknown

- bit 15 **ROI:** Recover on Interrupt bit
 1 = Interrupts clear the DOZEN bit and reset the CPU peripheral clock ratio to 1:1
 0 = Interrupts have no effect on the DOZEN bit
- bit 14-12 **DOZE[2:0]:** CPU Peripheral Clock Ratio Select bits
 111 = 1:128
 110 = 1:64
 101 = 1:32
 100 = 1:16
 011 = 1:8 (default)
 010 = 1:4
 001 = 1:2
 000 = 1:1
- bit 11 **DOZEN:** Doze Enable bit⁽¹⁾
 1 = DOZE[2:0] bits specify the CPU peripheral clock ratio
 0 = CPU peripheral clock ratio is set to 1:1
- bit 10-8 **RCDIV[2:0]:** System Frequency Divider Clock Source Select bits
 111 = Reserved; do not use
 110 = Reserved
 101 = Low-Power RC Oscillator (LPRC)
 100 = Secondary Oscillator (SOSC)
 011 = Primary Oscillator (XT, HS, EC) with PLL module (XTPLL, HSPLL, ECPLL)
 010 = Primary Oscillator (XT, HS, EC)
 001 = Fast RC Oscillator (FRC) with PLL module (FRCPLL)
 000 = Fast RC Oscillator (FRC)
- bit 7-6 **CPDIV[1:0]:** System Clock Select bits (postscaler select from PLL, 32 MHz clock branch)
 11 = 4 MHz (divide-by-8)
 10 = 8 MHz (divide-by-4)
 01 = 16 MHz (divide-by-2)
 00 = 32 MHz (divide-by-1)
- bit 5 **PLLEN:** PLL Enable bit
 1 = PLL is always active
 0 = PLL is only active when a PLL Oscillator mode is selected (OSCCON[14:12] = 011 or 001)
- bit 4-0 **Unimplemented:** Read as '0'

Note 1: This bit is automatically cleared when the ROI bit is set and an interrupt occurs.

PIC24FJ256GA705 FAMILY

REGISTER 9-3: OSCTUN: FRC OSCILLATOR TUNE REGISTER

U-0	U-0	U-0	U-0	U-0	U-0	U-0	U-0
—	—	—	—	—	—	—	—
bit 15							bit 8

U-0	U-0	R/W-0	R/W-0	R/W-0	R/W-0	R/W-0	R/W-0
—	—	TUN[5:0]					
bit 7							bit 0

Legend:

R = Readable bit W = Writable bit U = Unimplemented bit, read as '0'
 -n = Value at POR '1' = Bit is set '0' = Bit is cleared x = Bit is unknown

bit 15-6 **Unimplemented:** Read as '0'

bit 5-0 **TUN[5:0]:** FRC Oscillator Tuning bits

011111 = Maximum frequency deviation

011110 =

•

•

•

000001 =

000000 = Center frequency, oscillator is running at factory calibrated frequency

111111 =

•

•

•

100001 =

100000 = Minimum frequency deviation

PIC24FJ256GA705 FAMILY

REGISTER 9-4: OSCDIV: OSCILLATOR DIVISOR REGISTER

U-0	R/W-0	R/W-0	R/W-0	R/W-0	R/W-0	R/W-0	R/W-0	
—	DIV[14:8]							
bit 15								bit 8

R/W-0	R/W-0	R/W-0	R/W-0	R/W-0	R/W-0	R/W-0	R/W-1
DIV[7:0]							
bit 7							bit 0

Legend:

R = Readable bit	W = Writable bit	U = Unimplemented bit, read as '0'
-n = Value at POR	'1' = Bit is set	'0' = Bit is cleared x = Bit is unknown

bit 15 **Unimplemented:** Read as '0'

bit 14-0 **DIV[14:0]:** Reference Clock Divider bits

Specifies the 1/2 period of the reference clock in the source clocks
(ex: Period of ref_clk_output = [Reference Source * 2] * DIV[14:0]).

1111111111111111 = Oscillator frequency divided by 65,534 (32,767 * 2)

1111111111111110 = Oscillator frequency divided by 65,532 (32,766 * 2)

•

•

•

000000000000011 = Oscillator frequency divided by 6 (3 * 2)

000000000000010 = Oscillator frequency divided by 4 (2 * 2)

000000000000001 = Oscillator frequency divided by 2 (1 * 2) (default)

000000000000000 = Oscillator frequency is unchanged (no divider)

PIC24FJ256GA705 FAMILY

REGISTER 9-5: OSCFDIV: OSCILLATOR FRACTIONAL DIVISOR REGISTER⁽¹⁾

R/W-0	R/W-0	R/W-0	R/W-0	R/W-0	R/W-0	R/W-0	R/W-0	
TRIM[0:7]								
bit 15								bit 8

R/W-0	U-0	U-0	U-0	U-0	U-0	U-0	U-0	
TRIM8	—	—	—	—	—	—	—	
bit 7								bit 0

Legend:

R = Readable bit	W = Writable bit	U = Unimplemented bit, read as '0'
-n = Value at POR	'1' = Bit is set	'0' = Bit is cleared
		x = Bit is unknown

bit 15-7 **TRIM[0:8]** Trim bits
 Provides fractional additive to the DIV[14:0] bits value for the 1/2 period of the oscillator clock.
 0000_0000_0 = 0/512 (0.0) divisor added to DIVx value
 0000_0000_1 = 1/512 (0.001953125) divisor added to DIVx value
 0000_0001_0 = 2/512 (0.00390625) divisor added to DIVx value
 •
 •
 •
 100000000 = 256/512 (0.5000) divisor added to DIVx value
 •
 •
 •
 1111_1111_0 = 510/512 (0.99609375) divisor added to DIVx value
 1111_1111_1 = 511/512 (0.998046875) divisor added to DIVx value

bit 6-0 **Unimplemented:** Read as '0'

Note 1: TRIMx values greater than zero are ONLY valid when DIVx values are greater than zero.

PIC24FJ256GA705 FAMILY

9.4 Clock Switching Operation

With few limitations, applications are free to switch between any of the four clock sources (POSC, SOSC, FRC and LPRC) under software control and at any time. To limit the possible side effects that could result from this flexibility, PIC24F devices have a safeguard lock built into the switching process.

Note: The Primary Oscillator mode has three different submodes (XT, HS and EC), which are determined by the POSCMDx Configuration bits. While an application can switch to and from Primary Oscillator mode in software, it cannot switch between the different primary submodes without reprogramming the device.

9.4.1 ENABLING CLOCK SWITCHING

To enable clock switching, the FCKSM1 Configuration bit in FOSC must be programmed to '0'. (Refer to [Section 29.1 "Configuration Bits"](#) for further details.) If the FCKSM1 Configuration bit is unprogrammed ('1'), the clock switching function and Fail-Safe Clock Monitor function are disabled; this is the default setting.

The NOSCx control bits (OSCCON[10:8]) do not control the clock selection when clock switching is disabled. However, the COSCx[2:0] bits (OSCCON[14:12]) will reflect the clock source selected by the FNOSCx Configuration bits.

The OSWEN control bit (OSCCON[0]) has no effect when clock switching is disabled; it is held at '0' at all times.

9.4.2 OSCILLATOR SWITCHING SEQUENCE

At a minimum, performing a clock switch requires this basic sequence:

1. If desired, read the COSCx bits (OSCCON[14:12]) to determine the current oscillator source.
2. Perform the unlock sequence to allow a write to the OSCCON register high byte.
3. Write the appropriate value to the NOSCx bits (OSCCON[10:8]) for the new oscillator source.
4. Perform the unlock sequence to allow a write to the OSCCON register low byte.
5. Set the OSWEN bit to initiate the oscillator switch.

Once the basic sequence is completed, the system clock hardware responds automatically as follows:

1. The clock switching hardware compares the COSCx bits with the new value of the NOSCx bits. If they are the same, then the clock switch is a redundant operation. In this case, the OSWEN bit is cleared automatically and the clock switch is aborted.
2. If a valid clock switch has been initiated, the LOCK (OSCCON[5]) and CF (OSCCON[3]) bits are cleared.
3. The new oscillator is turned on by the hardware if it is not currently running. If a crystal oscillator must be turned on, the hardware will wait until the OST expires. If the new source is using the PLL, then the hardware waits until a PLL lock is detected (LOCK = 1).
4. The hardware waits for ten clock cycles from the new clock source and then performs the clock switch.
5. The hardware clears the OSWEN bit to indicate a successful clock transition. In addition, the NOSCx bits value is transferred to the COSCx bits.
6. The old clock source is turned off at this time, with the exception of LPRC (if WDT or FSCM is enabled) or SOSC (if SOSSEN remains set).

Note 1: The processor will continue to execute code throughout the clock switching sequence. Timing-sensitive code should not be executed during this time.

- 2: Direct clock switches between any Primary Oscillator mode with PLL and FRCPLL mode are not permitted. This applies to clock switches in either direction. In these instances, the application must switch to FRC mode as a transitional clock source between the two PLL modes.

A recommended code sequence for a clock switch includes the following:

1. Disable interrupts during the OSCCON register unlock and write sequence.
2. Execute the unlock sequence for the OSCCON high byte by writing 78h and 9Ah to OSCCON[15:8] in two back-to-back instructions.
3. Write the new oscillator source to the NOSCx bits in the instruction immediately following the unlock sequence.
4. Execute the unlock sequence for the OSCCON low byte by writing 46h and 57h to OSCCON[7:0] in two back-to-back instructions.
5. Set the OSWEN bit in the instruction immediately following the unlock sequence.
6. Continue to execute code that is not clock-sensitive (optional).
7. Invoke an appropriate amount of software delay (cycle counting) to allow the selected oscillator and/or PLL to start and stabilize.
8. Check to see if OSWEN is '0'. If it is, the switch was successful. If OSWEN is still set, then check the LOCK bit to determine the cause of the failure.

The core sequence for unlocking the OSCCON register and initiating a clock switch is shown in [Example 9-1](#).

EXAMPLE 9-1: BASIC CODE SEQUENCE FOR CLOCK SWITCHING

```
;Place the new oscillator selection in W0
;OSCCONH (high byte) Unlock Sequence
MOV      #OSCCONH, w1
MOV      #0x78, w2
MOV      #0x9A, w3
MOV.b    w2, [w1]
MOV.b    w3, [w1]
;Set new oscillator selection
MOV.b    WREG, OSCCONH
;OSCCONL (low byte) unlock sequence
MOV      #OSCCONL, w1
MOV      #0x46, w2
MOV      #0x57, w3
MOV.b    w2, [w1]
MOV.b    w3, [w1]
;Start oscillator switch operation
BSET     OSCCON, #0
```

PIC24FJ256GA705 FAMILY

9.5 Oscillator Modes

The PLL block is shown in [Figure 9-2](#). In this system, the input from the Primary Oscillator is divided down by a PLL prescaler to generate a 4 MHz output. This is used to drive an on-chip, 96 MHz PLL frequency multiplier to drive the fixed, divide-by-3 frequency divider and configurable PLL prescaler/divider to generate a range of system clock frequencies. The CPDIV[1:0] bits select the system clock speed. Available clock options are listed in [Table 9-2](#).

The user must manually configure the PLL divider to generate the required 4 MHz output using the PLLMODE[3:0] Configuration bits. This limits the choices for Primary Oscillator frequency to a total of eight possibilities, as shown in [Table 9-3](#).

TABLE 9-3: VALID PRIMARY OSCILLATOR CONFIGURATIONS

Input Oscillator Frequency	Clock Mode	PLL Mode (PLLMODE[3:0])
48 MHz	ECPLL	÷12 (0111)
32 MHz	HSPLL, ECPLL	÷8 (0110)
24 MHz	HSPLL, ECPLL	÷6 (0101)
20 MHz	HSPLL, ECPLL	÷5 (0100)
16 MHz	HSPLL, ECPLL	÷4 (0011)
12 MHz	HSPLL, ECPLL	÷3 (0010)
8 MHz	ECPLL, XTPLL, FRCPLL	÷2 (0001)
4 MHz	ECPLL, XTPLL, FRCPLL	÷1 (0000)

TABLE 9-2: SYSTEM CLOCK OPTIONS

MCU Clock Division (CPDIV[1:0])	Microcontroller Clock Frequency
None (00)	32 MHz
÷2 (01)	16 MHz
÷4 (10)	8 MHz
÷8 (11)	4 MHz

FIGURE 9-2: PLL BLOCK

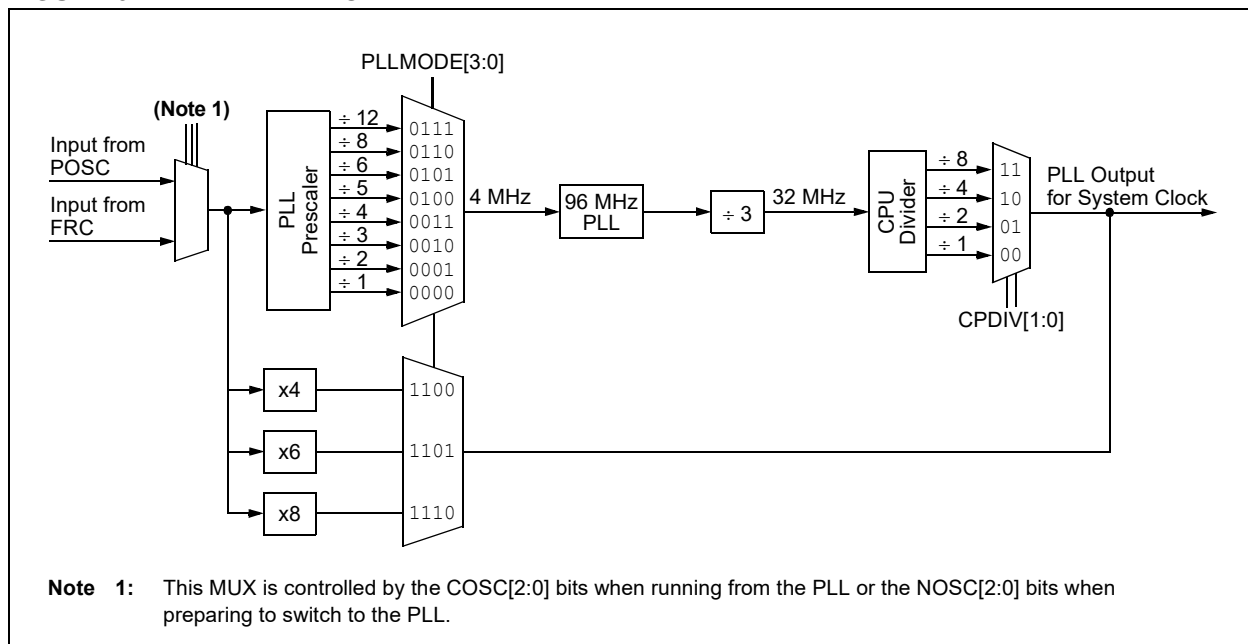

9.6 Reference Clock Output

In addition to the CLKO output ($F_{osc}/2$) available in certain Oscillator modes, the device clock in the PIC24FJ256GA705 family devices can also be configured to provide a reference clock output signal to a port pin. This feature is available in all oscillator configurations and allows the user to select a greater range of clock sub-multiples to drive external devices in the application. CLKO is enabled by Configuration bit, OSCIOFCN, and is independent of the REFO reference clock. REFO is mappable to any I/O pin that has mapped output capability. Refer to [Table 11-7](#) for more information.

This reference clock output is controlled by the REFOCONL and REFOCONH registers. Setting the ROEN bit (REFOCONL[15]) makes the clock signal available on the REFO pin. The RODIV[14:0] bits (REFOCONH[14:0]) enable the selection of different clock divider options. The ROSWEN bit (REFOCONL[9]) indicates that the clock divider has successfully switched. In order to switch the divider or trim the REFO frequency, the user should wait until this bit has been cleared. Write the updated values to RODIVx, set the ROSWEN bit and then wait until it is cleared before assuming that the REFO clock is valid.

The ROSEL[3:0] bits (REFOCONL[3:0]) determine which clock source is used for the reference clock output. The ROSLP bit (REFOCONL[11]) determines if the reference source is available on REFO when the device is in Sleep mode.

To use the reference clock output in Sleep mode, both the ROSLP bit must be set and the clock selected by the ROSELx bits must be enabled for operation during Sleep mode, if possible. Clearing the ROSELx bits allows the reference output frequency to change as the system clock changes during any clock switches. The ROOUT bit enables/disables the reference clock output on the REFO pin.

The ROACTIVE bit (REFOCONL[8]) indicates that the module is active; it can be cleared by disabling the module (setting ROEN to '0'). The user must not change the reference clock source or adjust the trim or divider when the ROACTIVE bit indicates that the module is active. To avoid glitches, the user should not disable the module until the ROACTIVE bit is '1'.

The PLLSS Configuration bit (FOSC[4]), when cleared, can be used to generate a REFO clock with the PLL that is independent of the system clock. The PLL cannot be used in the primary clock chain. For example, if the system clock is using FRC at 8 MHz, the PLL can use the FRC as the input and generate 32 MHz (PLL4x mode) out of REFO.

9.7 Secondary Oscillator

9.7.1 BASIC SOSC OPERATION

PIC24FJ256GA705 family devices do not have to set the SOSCEN bit to use the Secondary Oscillator. Any module requiring the SOSC (such as the RTCC or Timer1) will automatically turn on the SOSC when the clock signal is needed. The SOSC, however, has a long start-up time (as long as one second). To avoid delays for peripheral start-up, the SOSC can be manually started using the SOSCEN bit.

To use the Secondary Oscillator, the SOSCSEL bit (FOSC[3]) must be set to '1'. Programming the SOSCSEL bit to '0' configures the SOSC pins for Digital mode, enabling digital I/O functionality on the pins.

9.7.2 CRYSTAL SELECTION

The 32.768 kHz crystal used for the SOSC must have the following specifications in order to properly start up and run at the correct frequency when the SOSC is in High-Power mode (default):

- 12.5 pF loading capacitance
- 1.0 pF shunt capacitance
- A typical ESR of 35k-50k; 70k maximum

In addition, the two external crystal loading capacitors should be in the range of 18-22 pF, which will be based on the PC board layout. The capacitors should be C0G, 5% tolerance and rated 25V or greater.

The accuracy and duty cycle of the SOSC can be measured on the REFO pin, and is recommended to be in the range of 40-60% and accurate to ± 0.65 Hz.

9.7.3 LOW-POWER SOSC OPERATION

The Secondary Oscillator can operate in two distinct levels of power consumption based on device configuration. In Low-Power mode, the oscillator operates in a low drive strength, low-power state. By default, the oscillator uses a higher drive strength, and therefore, requires more power. Low-Power mode is selected by Configuration bit, SOSCHP (FDEVOPT1[3]). The lower drive strength of this mode makes the SOSC more sensitive to noise and requires a longer start-up time. This mode can be used with lower load capacitance crystals (6 pF-9 pF) to reduce Sleep current in the RTCC. When Low-Power mode is used, care must be taken in the design and layout of the SOSC circuit to ensure that the oscillator starts up and oscillates properly. PC board layout issues, stray capacitance and other factors will need to be carefully controlled in order for the crystal to operate.

PIC24FJ256GA705 FAMILY

REGISTER 9-6: REFOCONL: REFERENCE OSCILLATOR CONTROL REGISTER LOW

R/W-0	U-0	R/W-0	R/W-0	R/W-0	U-0	R/W-0	R-0
ROEN	—	ROSIDL	ROOUT	ROSLP	—	ROSWEN	ROACTIVE
bit 15							bit 8

U-0	U-0	U-0	U-0	R/W-0	R/W-0	R/W-0	R/W-0
—	—	—	—	ROSEL[3:0]			
bit 7							bit 0

Legend:

R = Readable bit

W = Writable bit

U = Unimplemented bit, read as '0'

-n = Value at POR

'1' = Bit is set

'0' = Bit is cleared

x = Bit is unknown

- bit 15 **ROEN:** Reference Oscillator Output Enable bit
 1 = Reference Oscillator module is enabled
 0 = Reference Oscillator is disabled
- bit 14 **Unimplemented:** Read as '0'
- bit 13 **ROSIDL:** REFO Stop in Idle Mode bit
 1 = Discontinues module operation when device enters Idle mode
 0 = Continues module operation in Idle mode
- bit 12 **ROOUT:** Reference Clock Output Enable bit
 1 = Reference clock is driven out on the REFO pin
 0 = Reference clock is not driven out on the REFO pin
- bit 11 **ROSLP:** Reference Oscillator Output Stop in Sleep bit
 1 = Reference Oscillator continues to run in Sleep
 0 = Reference Oscillator is disabled in Sleep
- bit 10 **Unimplemented:** Read as '0'
- bit 9 **ROSWEN:** Reference Clock RODIVx Switch Enable bit
 1 = Switch clock divider; clock divider switching is currently in progress
 0 = Clock divider switch has been completed
- bit 8 **ROACTIVE:** Reference Clock Request Status bit
 1 = Reference clock is active (user should not change the REFO settings)
 0 = Reference clock is inactive (user can update the REFO settings)
- bit 7-4 **Unimplemented:** Read as '0'
- bit 3-0 **ROSEL[3:0]:** Reference Clock Source Select bits
 1111-1001 = Reserved
 1000 = REFI pin
 0111 = Reserved
 0110 = PLL
 0101 = SOSC
 0100 = LPRC
 0011 = FRC
 0010 = POSC
 0001 = System clock (Fosc/2)
 0000 = Fosc

PIC24FJ256GA705 FAMILY

REGISTER 9-7: REFOCONH: REFERENCE OSCILLATOR CONTROL REGISTER HIGH

U-0	R/W-0	R/W-0	R/W-0	R/W-0	R/W-0	R/W-0	R/W-0	
—	RODIV[14:8]							
bit 15								bit 8

R/W-0	R/W-0	R/W-0	R/W-0	R/W-0	R/W-0	R/W-0	R/W-0
RODIV[7:0]							
bit 7							bit 0

Legend:			
R = Readable bit	W = Writable bit	U = Unimplemented bit, read as '0'	
-n = Value at POR	'1' = Bit is set	'0' = Bit is cleared	x = Bit is unknown

bit 15 **Unimplemented:** Read as '0'

bit 14-0 **RODIV[14:0]:** Reference Clock Divider bits
 Specifies 1/2 period of the reference clock in the source clocks
 (ex: Period of Output = [Reference Source * 2] * RODIV[14:0]; this equation does not apply to RODIV[14:0] = 0).
 1111111111111111 = REFO clock is the base clock frequency divided by 65,534 (32,767 * 2)
 1111111111111110 = REFO clock is the base clock frequency divided by 65,532 (32,766 * 2)
 •
 •
 •
 0000000000000011 = REFO clock is the base clock frequency divided by 6 (3 * 2)
 0000000000000010 = REFO clock is the base clock frequency divided by 4 (2 * 2)
 0000000000000001 = REFO clock is the base clock frequency divided by 2 (1 * 2)
 0000000000000000 = REFO clock is the same frequency as the base clock (no divider)

PIC24FJ256GA705 FAMILY

NOTES:

10.0 POWER-SAVING FEATURES

Note: This data sheet summarizes the features of this group of PIC24F devices. It is not intended to be a comprehensive reference source. For more information, refer to “**Power-Saving Features with Deep Sleep**” (www.microchip.com/DS39727) in the “*dsPIC33/PIC24 Family Reference Manual*”. The information in this data sheet supersedes the information in the FRM.

The PIC24FJ256GA705 family of devices provides the ability to manage power consumption by selectively managing clocking to the CPU and the peripherals. In general, a lower clock frequency and a reduction in the number of circuits being clocked constitutes lower consumed power. All PIC24F devices manage power consumption in four different ways:

- Clock Frequency
- Instruction-Based Sleep and Idle modes
- Software Controlled Doze mode
- Selective Peripheral Control in Software

Combinations of these methods can be used to selectively tailor an application’s power consumption, while still maintaining critical application features, such as timing-sensitive communications.

10.1 Clock Frequency and Clock Switching

PIC24F devices allow for a wide range of clock frequencies to be selected under application control. If the system clock configuration is not locked, users can choose low-power or high-precision oscillators by simply changing the NOSC[2:0] bits. The process of changing a system clock during operation, as well as limitations to the process, are discussed in more detail in [Section 9.0 “Oscillator Configuration”](#).

10.2 Instruction-Based Power-Saving Modes

PIC24F devices have two special power-saving modes that are entered through the execution of a special PWRSAV instruction. Sleep mode stops clock operation and halts all code execution; Idle mode halts the CPU and code execution, but allows peripheral modules to continue operation. The assembly syntax of the PWRSAV instruction is shown in [Example 10-1](#).

EXAMPLE 10-1: PWRSAV INSTRUCTION SYNTAX

```
PWRSAV    #SLEEP_MODE           ; Put the device into SLEEP mode
PWRSAV    #IDLE_MODE            ; Put the device into IDLE mode
```

The MPLAB® XC16 C compiler offers “built-in” functions for the power-saving modes as follows:

```
Idle();    // places part in Idle
Sleep();   // places part in Sleep
```

Sleep and Idle modes can be exited as a result of an enabled interrupt, WDT time-out or a device Reset. When the device exits these modes, it is said to “wake-up”.

Note: SLEEP_MODE and IDLE_MODE are constants defined in the assembler include file for the selected device.

10.2.1 SLEEP MODE

Sleep mode has these features:

- The system clock source is shut down. If an on-chip oscillator is used, it is turned off.
- The device current consumption will be reduced to a minimum provided that no I/O pin is sourcing current.
- The Fail-Safe Clock Monitor does not operate during Sleep mode since the system clock source is disabled.
- The LPRC clock will continue to run in Sleep mode if the WDT is enabled.
- The WDT, if enabled, is automatically cleared prior to entering Sleep mode.
- Some device features or peripherals may continue to operate in Sleep mode. This includes items, such as the Input Change Notification (ICN) on the I/O ports or peripherals that use an external clock input. Any peripheral that requires the system clock source for its operation will be disabled in Sleep mode.

The device will wake-up from Sleep mode on any of the these events:

- On any interrupt source that is individually enabled
- On any form of device Reset
- On a WDT time-out

On wake-up from Sleep, the processor will restart with the same clock source that was active when Sleep mode was entered.

PIC24FJ256GA705 FAMILY

10.2.2 IDLE MODE

Idle mode has these features:

- The CPU will stop executing instructions.
- The WDT is automatically cleared.
- The system clock source remains active. By default, all peripheral modules continue to operate normally from the system clock source, but can also be selectively disabled (see [Section 10.4 “Selective Peripheral Module Control”](#)).
- If the WDT or FSCM is enabled, the LPRC will also remain active.

The device will wake from Idle mode on any of these events:

- Any interrupt that is individually enabled.
- Any device Reset.
- A WDT time-out.

On wake-up from Idle, the clock is reapplied to the CPU and instruction execution begins immediately, starting with the instruction following the `PWRSVAV` instruction or the first instruction in the ISR.

10.2.3 INTERRUPTS COINCIDENT WITH POWER SAVE INSTRUCTIONS

Any interrupt that coincides with the execution of a `PWRSVAV` instruction will be held off until entry into Sleep or Idle mode has completed. The device will then wake-up from Sleep or Idle mode.

10.2.4 LOW-VOLTAGE RETENTION REGULATOR

PIC24FJ256GA705 family devices incorporate a second on-chip voltage regulator, designed to provide power to select microcontroller features at 1.2V nominal. This regulator allows features, such as data RAM and the WDT, to be maintained in power-saving modes where they would otherwise be inactive, or maintain them at a lower power than would otherwise be the case.

Retention Sleep uses less power than standard Sleep mode, but takes more time to recover and begin execution. An additional 10-15 μs (typical) is required to charge `VCAP` from 1.2V to 1.8V and start to execute instructions when exiting Retention Sleep.

The `VREGS` bit allows control of speed to exit from the Sleep modes (regular and Retention) at the cost of more power. The regulator band gaps are enabled, which increases the current but reduces time to recover from Sleep by $\sim 10 \mu\text{s}$.

The low-voltage retention regulator is only available when Sleep mode is invoked. It is controlled by the `LPCFG` Configuration bit (`FPOR[2]`) and in firmware by the `RETEN` bit (`RCON[12]`). `LPCFG` must be programmed (`= 0`) and the `RETEN` bit must be set (`= 1`) for the regulator to be enabled.

10.2.5 EXITING FROM LOW-VOLTAGE RETENTION SLEEP

All of the methods for exiting from standard Sleep also apply to Retention Sleep (`MCLR`, `INT0`, etc.). However, in order to allow the regulator to switch from 1.8V (operating) to Retention mode (1.2V), there is a hardware ‘lockout timer’ from the execution of Retention Sleep until Retention Sleep can be exited.

During the ‘lockout time’, the only method to exit Retention Sleep is a POR or `MCLR`. Interrupts that are asserted (such as `INT0`) during the ‘lockout time’ are masked. The lockout timer then sets a minimum interval from when the part enters Retention Sleep until it can exit from Retention Sleep. Interrupts are not ‘held pending’ during lockout; they are masked and in order to exit after the lockout expires, the exiting source must assert after the lockout time.

The lockout timer is derived from the LPRC clock, which has a wide (untrimmed) frequency tolerance.

The lockout time will be one of the following two cases:

- If the LPRC was not running at the time of Retention Sleep, the lockout time is 2 LPRC periods + LPRC wake-up time
- If the LPRC was running at the time of Retention Sleep, the lockout time is 1 LPRC period

Refer to [Table 32-20](#) and [Table 32-21](#) in the AC Electrical Specifications for the LPRC timing.

10.2.6 SUMMARY OF LOW-POWER SLEEP MODES

The `RETEN` bit and the `VREGS` bit (`RCON[12,8]`) allow for four different Sleep modes, which will vary by wake-up time and power consumption. Refer to [Table 10-1](#) for a summary of these modes. Specific information about the current consumption and wake times can be found in [Section 32.0 “Electrical Characteristics”](#).

TABLE 10-1: LOW-POWER SLEEP MODES

RETEN	VREGS	MODE	Relative Power
0	1	Sleep	100 μA Range
0	0	Fast Wake-up	A Few μA Range
1	1	Retention Sleep	A 1 μA Range
1	0	Fast Retention	Less than 1 μA

10.3 Doze Mode

Generally, changing clock speed and invoking one of the power-saving modes are the preferred strategies for reducing power consumption. There may be circumstances, however, where this is not practical. For example, it may be necessary for an application to maintain uninterrupted synchronous communication, even while it is doing nothing else. Reducing system clock speed may introduce communication errors, while using a power-saving mode may stop communications completely.

Doze mode is a simple and effective alternative method to reduce power consumption while the device is still executing code. In this mode, the system clock continues to operate from the same source and at the same speed. Peripheral modules continue to be clocked at the same speed while the CPU clock speed is reduced. Synchronization between the two clock domains is maintained, allowing the peripherals to access the SFRs while the CPU executes code at a slower rate.

Doze mode is enabled by setting the DOZEN bit (CLKDIV[11]). The ratio between peripheral and core clock speed is determined by the DOZE[2:0] bits (CLKDIV[14:12]). There are eight possible configurations, from 1:1 to 1:256, with 1:1 being the default.

It is also possible to use Doze mode to selectively reduce power consumption in event driven applications. This allows clock-sensitive functions, such as synchronous communications, to continue without interruption while the CPU Idles, waiting for something to invoke an interrupt routine. Enabling the automatic return to full-speed CPU operation on interrupts is enabled by setting the ROI bit (CLKDIV[15]). By default, interrupt events have no effect on Doze mode operation.

10.4 Selective Peripheral Module Control

Idle and Doze modes allow users to substantially reduce power consumption by slowing or stopping the CPU clock. Even so, peripheral modules still remain clocked, and thus, consume power. There may be cases where the application needs what these modes do not provide: the allocation of power resources to CPU processing with minimal power consumption from the peripherals.

PIC24F devices address this requirement by allowing peripheral modules to be selectively disabled, reducing or eliminating their power consumption. This can be done with two control bits:

- The Peripheral Enable bit, generically named, “XXXEN”, located in the module’s main control SFR.
- The Peripheral Module Disable (PMD) bit, generically named, “XXXMD”, located in one of the PMD Control registers.

Both bits have similar functions in enabling or disabling their associated module. Setting the PMD bit for a module disables all clock sources to that module, reducing its power consumption to an absolute minimum. In this state, the control and status registers associated with the peripheral will also be disabled, so writes to those registers will have no effect and read values will be invalid. Many peripheral modules have a corresponding PMD bit.

In contrast, disabling a module by clearing its XXXEN bit disables its functionality, but leaves its registers available to be read and written to. This reduces power consumption, but not by as much as setting the PMD bit does. Most peripheral modules have an enable bit; exceptions include input capture, output compare and RTCC.

To achieve more selective power savings, peripheral modules can also be selectively disabled when the device enters Idle mode. This is done through the control bit of the generic name format, “XXXIDL”. By default, all modules that can operate during Idle mode will do so. Using the disable on Idle feature allows further reduction of power consumption during Idle mode, enhancing power savings for extremely critical power applications.

TABLE 10-2: PERIPHERAL MODULE DISABLE REGISTER SUMMARY

Register	Bit 15	Bit 14	Bit 13	Bit 12	Bit 11	Bit 10	Bit 9	Bit 8	Bit 7	Bit 6	Bit 5	Bit 4	Bit 3	Bit 2	Bit 1	Bit 0	All Resets
PMD1	—	—	T3MD	T2MD	T1MD	—	—	—	I2C1MD	U2MD	U1MD	SPI2MD	SPI1MD	—	—	ADCMD	0000
PMD2	—	—	—	—	—	IC3MD	IC2MD	IC1MD	—	—	—	—	—	OC3MD	OC2MD	OC1MD	0000
PMD3	—	—	—	—	—	CMPMD	RTCCMD	PMPMD	CRCMD	—	—	—	—	—	I2C2MD	—	0000
PMD4	—	—	—	—	—	—	—	—	—	—	—	—	REFOMD	CTMUMD	LVDMD	—	0000
PMD5	—	—	—	—	—	—	—	—	—	—	—	—	CCP4MD	CCP3MD	CCP2MD	CCP1MD	0000
PMD6	—	—	—	—	—	—	—	—	—	—	—	—	—	—	—	SPI3MD	0000
PMD7	—	—	—	—	—	—	—	—	—	—	DMA1MD	DMA0MD	—	—	—	—	0000
PMD8	—	—	—	—	—	—	—	—	—	—	—	—	CLC2MD	CLC1MD	—	—	0000

Legend: — = unimplemented, read as '0'. Reset values are shown in hexadecimal.

REGISTER 10-1: PMD1: PERIPHERAL MODULE DISABLE REGISTER 1

U-0	U-0	R/W-0	R/W-0	R/W-0	U-0	U-0	U-0
—	—	T3MD	T2MD	T1MD	—	—	—
bit 15						bit 8	

R/W-0	R/W-0	R/W-0	R/W-0	R/W-0	U-0	U-0	R/W-0
I2C1MD	U2MD	U1MD	SPI2MD	SPI1MD	—	—	ADC1MD
bit 7						bit 0	

Legend:

R = Readable bit	W = Writable bit	U = Unimplemented bit, read as '0'
-n = Value at POR	'1' = Bit is set	'0' = Bit is cleared
		x = Bit is unknown

- bit 15-14 **Unimplemented:** Read as '0'
- bit 13 **T3MD:** Timer3 Module Disable bit
1 = Module is disabled
0 = Module power and clock sources are enabled
- bit 12 **T2MD:** Timer2 Module Disable bit
1 = Module is disabled
0 = Module power and clock sources are enabled
- bit 11 **T1MD:** Timer1 Module Disable bit
1 = Module is disabled
0 = Module power and clock sources are enabled
- bit 10-8 **Unimplemented:** Read as '0'
- bit 7 **I2C1MD:** I2C1 Module Disable bit
1 = Module is disabled
0 = Module power and clock sources are enabled
- bit 6 **U2MD:** UART2 Module Disable bit
1 = Module is disabled
0 = Module power and clock sources are enabled
- bit 5 **U1MD:** UART1 Module Disable bit
1 = Module is disabled
0 = Module power and clock sources are enabled
- bit 4 **SPI2MD:** SPI2 Module Disable bit
1 = Module is disabled
0 = Module power and clock sources are enabled
- bit 3 **SPI1MD:** SPI1 Module Disable bit
1 = Module is disabled
0 = Module power and clock sources are enabled
- bit 2-1 **Unimplemented:** Read as '0'
- bit 0 **ADC1MD:** A/D Converter Module Disable bit
1 = Module is disabled
0 = Module power and clock sources are enabled

PIC24FJ256GA705 FAMILY

REGISTER 10-2: PMD2: PERIPHERAL MODULE DISABLE REGISTER 2

U-0	U-0	U-0	U-0	U-0	R/W-0	R/W-0	R/W-0
—	—	—	—	—	IC3MD	IC2MD	IC1MD
bit 15					bit 8		

U-0	U-0	U-0	U-0	U-0	R/W-0	R/W-0	R/W-0
—	—	—	—	—	OC3MD	OC2MD	OC1MD
bit 7					bit 0		

Legend:

R = Readable bit

W = Writable bit

U = Unimplemented bit, read as '0'

-n = Value at POR

'1' = Bit is set

'0' = Bit is cleared

x = Bit is unknown

- bit 15-11 **Unimplemented:** Read as '0'
- bit 10 **IC3MD:** Input Capture 3 Module Disable bit
 1 = Module is disabled
 0 = Module power and clock sources are enabled
- bit 9 **IC2MD:** Input Capture 2 Module Disable bit
 1 = Module is disabled
 0 = Module power and clock sources are enabled
- bit 8 **IC1MD:** Input Capture 1 Module Disable bit
 1 = Module is disabled
 0 = Module power and clock sources are enabled
- bit 7-3 **Unimplemented:** Read as '0'
- bit 2 **OC3MD:** Output Compare 3 Module Disable bit
 1 = Module is disabled
 0 = Module power and clock sources are enabled
- bit 1 **OC2MD:** Output Compare 2 Module Disable bit
 1 = Module is disabled
 0 = Module power and clock sources are enabled
- bit 0 **OC1MD:** Output Compare 1 Module Disable bit
 1 = Module is disabled
 0 = Module power and clock sources are enabled

PIC24FJ256GA705 FAMILY

REGISTER 10-3: PMD3: PERIPHERAL MODULE DISABLE REGISTER 3

U-0	U-0	U-0	U-0	U-0	R/W-0	R/W-0	R/W-0
—	—	—	—	—	CMPMD	RTCCMD	PMPMD
bit 15						bit 8	

R/W-0	U-0	U-0	U-0	U-0	U-0	R/W-0	U-0
CRCMD	—	—	—	—	—	I2C2MD	—
bit 7						bit 0	

Legend:

R = Readable bit

W = Writable bit

U = Unimplemented bit, read as '0'

-n = Value at POR

'1' = Bit is set

'0' = Bit is cleared

x = Bit is unknown

- bit 15-11 **Unimplemented:** Read as '0'
- bit 10 **CMPMD:** Triple Comparator Module Disable bit
 1 = Module is disabled
 0 = Module power and clock sources are enabled
- bit 9 **RTCCMD:** RTCC Module Disable bit
 1 = Module is disabled
 0 = Module power and clock sources are enabled
- bit 8 **PMPMD:** Enhanced Parallel Master Port Disable bit
 1 = Module is disabled
 0 = Module power and clock sources are enabled
- bit 7 **CRCMD:** CRC Module Disable bit
 1 = Module is disabled
 0 = Module power and clock sources are enabled
- bit 6-2 **Unimplemented:** Read as '0'
- bit 1 **I2C2MD:** I2C2 Module Disable bit
 1 = Module is disabled
 0 = Module power and clock sources are enabled
- bit 0 **Unimplemented:** Read as '0'

PIC24FJ256GA705 FAMILY

REGISTER 10-4: PMD4: PERIPHERAL MODULE DISABLE REGISTER 4

U-0	U-0	U-0	U-0	U-0	U-0	U-0	U-0
—	—	—	—	—	—	—	—
bit 15							bit 8

U-0	U-0	U-0	U-0	R/W-0	R/W-0	R/W-0	U-0
—	—	—	—	REFOMD	CTMUMD	LVDMD	—
bit 7							bit 0

Legend:

R = Readable bit

W = Writable bit

U = Unimplemented bit, read as '0'

-n = Value at POR

'1' = Bit is set

'0' = Bit is cleared

x = Bit is unknown

bit 15-4 **Unimplemented:** Read as '0'

bit 3 **REFOMD:** Reference Output Clock Disable bit

1 = Module is disabled

0 = Module power and clock sources are enabled

bit 2 **CTMUMD:** CTMU Module Disable bit

1 = Module is disabled

0 = Module power and clock sources are enabled

bit 1 **LVDMD:** High/Low-Voltage Detect Module Disable bit

1 = Module is disabled

0 = Module power and clock sources are enabled

bit 0 **Unimplemented:** Read as '0'

PIC24FJ256GA705 FAMILY

REGISTER 10-5: PMD5: PERIPHERAL MODULE DISABLE REGISTER 5

U-0	U-0	U-0	U-0	U-0	U-0	U-0	U-0
—	—	—	—	—	—	—	—
bit 15							bit 8

U-0	U-0	U-0	U-0	R/W-0	R/W-0	R/W-0	R/W-0
—	—	—	—	CCP4MD	CCP3MD	CCP2MD	CCP1MD
bit 7							bit 0

Legend:

R = Readable bit W = Writable bit U = Unimplemented bit, read as '0'
 -n = Value at POR '1' = Bit is set '0' = Bit is cleared x = Bit is unknown

- bit 15-4 **Unimplemented:** Read as '0'
- bit 3 **CCP4MD:** M CCP4 Module Disable bit
 - 1 = Module is disabled
 - 0 = Module power and clock sources are enabled
- bit 2 **CCP3MD:** M CCP3 Module Disable bit
 - 1 = Module is disabled
 - 0 = Module power and clock sources are enabled
- bit 1 **CCP2MD:** M CCP2 Module Disable bit
 - 1 = Module is disabled
 - 0 = Module power and clock sources are enabled
- bit 0 **CCP1MD:** M CCP1 Module Disable bit
 - 1 = Module is disabled
 - 0 = Module power and clock sources are enabled

PIC24FJ256GA705 FAMILY

REGISTER 10-6: PMD6: PERIPHERAL MODULE DISABLE REGISTER 6

U-0	U-0	U-0	U-0	U-0	U-0	U-0	U-0
—	—	—	—	—	—	—	—
bit 15							bit 8

U-0	U-0	U-0	U-0	U-0	U-0	U-0	R/W-0
—	—	—	—	—	—	—	SPI3MD
bit 7							bit 0

Legend:

R = Readable bit W = Writable bit U = Unimplemented bit, read as '0'
 -n = Value at POR '1' = Bit is set '0' = Bit is cleared x = Bit is unknown

bit 15-1 **Unimplemented:** Read as '0'
 bit 0 **SPI3MD:** SPI3 Module Disable bit
 1 = Module is disabled
 0 = Module power and clock sources are enabled

REGISTER 10-7: PMD7: PERIPHERAL MODULE DISABLE REGISTER 7

U-0	U-0	U-0	U-0	U-0	U-0	U-0	U-0
—	—	—	—	—	—	—	—
bit 15							bit 8

U-0	U-0	R/W-0	R/W-0	U-0	U-0	U-0	U-0
—	—	DMA1MD	DMA0MD	—	—	—	—
bit 7							bit 0

Legend:

R = Readable bit W = Writable bit U = Unimplemented bit, read as '0'
 -n = Value at POR '1' = Bit is set '0' = Bit is cleared x = Bit is unknown

bit 15-6 **Unimplemented:** Read as '0'
 bit 5 **DMA1MD:** DMA1 Controller (Channels 4 through 7) Disable bit
 1 = Controller is disabled
 0 = Controller power and clock sources are enabled
 bit 4 **DMA0MD:** DMA0 Controller (Channels 0 through 3) Disable bit
 1 = Controller is disabled
 0 = Controller power and clock sources are enabled
 bit 3-0 **Unimplemented:** Read as '0'

PIC24FJ256GA705 FAMILY

REGISTER 10-8: PMD8: PERIPHERAL MODULE DISABLE REGISTER 8

U-0	U-0	U-0	U-0	U-0	U-0	U-0	U-0
—	—	—	—	—	—	—	—
bit 15							bit 8

U-0	U-0	U-0	U-0	R/W-0	R/W-0	U-0	U-0
—	—	—	—	CLC2MD	CLC1MD	—	—
bit 7					bit 0		

Legend:

R = Readable bit W = Writable bit U = Unimplemented bit, read as '0'
 -n = Value at POR '1' = Bit is set '0' = Bit is cleared x = Bit is unknown

- bit 15-4 **Unimplemented:** Read as '0'
- bit 3 **CLC2MD:** CLC2 Module Disable bit
 - 1 = Module is disabled
 - 0 = Module power and clock sources are enabled
- bit 2 **CLC1MD:** CLC1 Module Disable bit
 - 1 = Module is disabled
 - 0 = Module power and clock sources are enabled
- bit 1-0 **Unimplemented:** Read as '0'

PIC24FJ256GA705 FAMILY

NOTES:

11.0 I/O PORTS

Note: This data sheet summarizes the features of this group of PIC24F devices. It is not intended to be a comprehensive reference source. For more information, refer to **“I/O Ports with Peripheral Pin Select (PPS)”** (www.microchip.com/DS30009711) in the *“dsPIC33/PIC24 Family Reference Manual”*. The information in this data sheet supersedes the information in the FRM.

All of the device pins (except VDD, VSS, MCLR and OSC1/CLK1) are shared between the peripherals and the Parallel I/O (PIO) ports. All I/O input ports feature Schmitt Trigger (ST) inputs for improved noise immunity.

11.1 Parallel I/O (PIO) Ports

A Parallel I/O port that shares a pin with a peripheral is, in general, subservient to the peripheral. The peripheral's output buffer data and control signals are provided to a pair of multiplexers. The multiplexers select whether the peripheral or the associated port has ownership of the output data and control signals of the I/O pin. The logic also prevents “loop through”, in which a port's digital output can drive the input of a

peripheral that shares the same pin. [Figure 11-1](#) shows how ports are shared with other peripherals and the associated I/O pin to which they are connected.

When a peripheral is enabled and the peripheral is actively driving an associated pin, the use of the pin as a general purpose output pin is disabled. The I/O pin may be read, but the output driver for the parallel port bit will be disabled. If a peripheral is enabled, but the peripheral is not actively driving a pin, that pin may be driven by a port.

All port pins have three registers directly associated with their operation as digital I/Os and one register associated with their operation as analog inputs. The Data Direction register (TRISx) determines whether the pin is an input or an output. If the data direction bit is a ‘1’, then the pin is an input. All port pins are defined as inputs after a Reset. Reads from the Output Latch register (LATx), read the latch; writes to the latch, write the latch. Reads from the PORTx register, read the port pins; writes to the port pins, write the latch.

Any bit and its associated data and control registers that are not valid for a particular device will be disabled. That means the corresponding LATx and TRISx registers, and the port pin, will read as zeros. [Table 11-3](#) through [Table 11-5](#) show ANSELx bits and ports availability for device variants. When a pin is shared with another peripheral or function that is defined as an input only, it is regarded as a dedicated port because there is no other competing source of inputs.

FIGURE 11-1: BLOCK DIAGRAM OF A TYPICAL SHARED PORT STRUCTURE

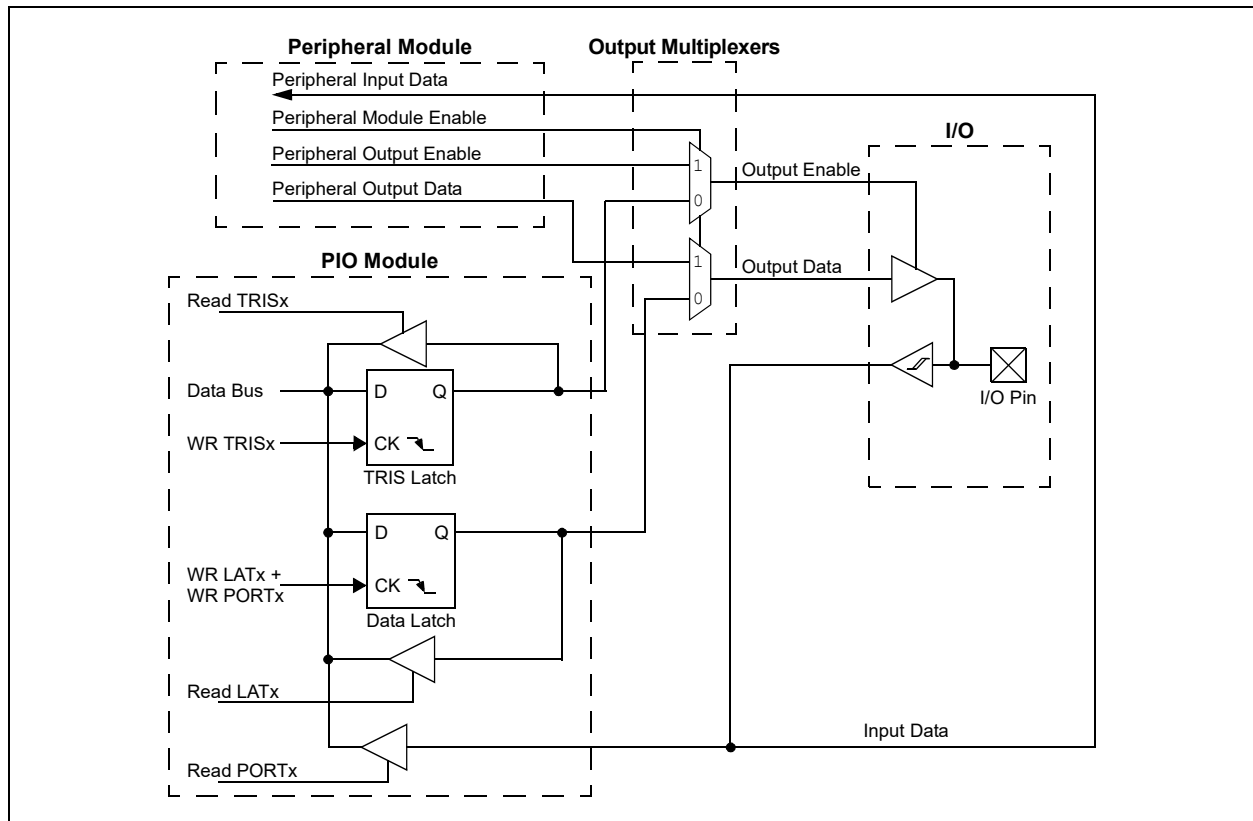

PIC24FJ256GA705 FAMILY

11.1.1 I/O PORT WRITE/READ TIMING

One instruction cycle is required between a port direction change or port write operation and a read operation of the same port. Typically, this instruction would be a NOP.

11.1.2 OPEN-DRAIN CONFIGURATION

In addition to the PORTx, LATx and TRISx registers for data control, each port pin can also be individually configured for either a digital or open-drain output. This is controlled by the Open-Drain Control register, ODCx, associated with each port. Setting any of the bits configures the corresponding pin to act as an open-drain output.

The open-drain feature allows the generation of outputs higher than VDD (e.g., 5V) on any desired digital only pins by using external pull-up resistors. The maximum open-drain voltage allowed is the same as the maximum VIH specification.

11.2 Configuring Analog Port Pins (ANSx)

The ANSx and TRISx registers control the operation of the pins with analog function. Each port pin with analog function is associated with one of the ANSx bits, which decide if the pin function should be analog or digital. Refer to [Table 11-1](#) for detailed behavior of the pin for different ANSx and TRISx bit settings.

When reading the PORTx register, all pins configured as analog input channels will read as cleared (a low level).

11.2.1 ANALOG INPUT PINS AND VOLTAGE CONSIDERATIONS

The voltage tolerance of pins used as device inputs is dependent on the pin's input function. Most input pins are able to handle DC voltages of up to 5.5V, a level typical for digital logic circuits. However, several pins can only tolerate voltages up to VDD. Voltage excursions beyond VDD on these pins should always be avoided.

[Table 11-2](#) summarizes the different voltage tolerances. For more information, refer to [Section 32.0 "Electrical Characteristics"](#) for more details.

TABLE 11-1: CONFIGURING ANALOG/DIGITAL FUNCTION OF AN I/O PIN

Pin Function	ANSx Setting	TRISx Setting	Comments
Analog Input	1	1	It is recommended to keep ANSx = 1.
Analog Output	1	1	It is recommended to keep ANSx = 1.
Digital Input	0	1	Firmware must wait at least one instruction cycle after configuring a pin as a digital input before a valid input value can be read.
Digital Output	0	0	Make sure to disable the analog output function on the pin if any is present.

TABLE 11-2: INPUT VOLTAGE LEVELS FOR PORT OR PIN TOLERATED DESCRIPTION INPUT

Port or Pin	Tolerated Input	Description
PORTB[11:10,8:5] PORTC[9:6]	5.5V	Tolerates input levels above VDD; useful for most standard logic.
PORTA[14:7,4:0] PORTB[15:12,9,4:0] PORTC[5:0]	VDD	Only VDD input levels are tolerated.

PIC24FJ256GA705 FAMILY

TABLE 11-3: PORTA PIN AND ANSELx AVAILABILITY

Device	PORTA I/O Pins															
	RA15	RA14	RA13	RA12	RA11	RA10	RA9	RA8	RA7	RA6	RA5	RA4	RA3	RA2	RA1	RA0
PIC24FJXXXGA705	—	X	X	X	X	X	X	X	X	—	—	X	X	X	X	X
PIC24FJXXXGA704	—	—	—	—	—	X	X	X	X	—	—	X	X	X	X	X
PIC24FJXXXGA702	—	—	—	—	—	—	—	—	—	—	—	X	X	X	X	X
ANSELA Bit Present	—	—	—	—	—	—	—	—	—	—	—	—	X	X	X	X

TABLE 11-4: PORTB PIN AND ANSELx AVAILABILITY

Device	PORTB I/O Pins															
	RB15	RB14	RB13	RB12	RB11	RB10	RB9	RB8	RB7	RB6	RB5	RB4	RB3	RB2	RB1	RB0
PIC24FJXXXGA705	X	X	X	X	X	X	X	X	X	X	X	X	X	X	X	X
PIC24FJXXXGA704	X	X	X	X	X	X	X	X	X	X	X	X	X	X	X	X
PIC24FJXXXGA702	X	X	X	X	X	X	X	X	X	X	X	X	X	X	X	X
ANSELB Bit Present	X	X	X	X	—	—	X	—	—	—	—	—	X	X	X	X

TABLE 11-5: PORTC PIN AND ANSELx AVAILABILITY

Device	PORTC I/O Pins															
	RC15	RC14	RC13	RC12	RC11	RC10	RC9	RC8	RC7	RC6	RC5	RC4	RC3	RC2	RC1	RC0
PIC24FJXXXGA705	—	—	—	—	—	—	X	X	X	X	X	X	X	X	X	X
PIC24FJXXXGA704	—	—	—	—	—	—	X	X	X	X	X	X	X	X	X	X
PIC24FJXXXGA702	—	—	—	—	—	—	—	—	—	—	—	—	—	—	—	—
ANSELC Bit Present	—	—	—	—	—	—	—	—	—	—	—	—	X	X	X	X

PIC24FJ256GA705 FAMILY

11.3 Interrupt-on-Change (IOC)

The interrupt-on-change function of the I/O ports allows the PIC24FJ256GA705 family of devices to generate interrupt requests to the processor in response to a Change-of-State (COS) on selected input pins. This feature is capable of detecting input Change-of-States, even in Sleep mode, when the clocks are disabled.

Interrupt-on-change functionality is enabled on a pin by setting the IOCPx and/or IOCNx register bit for that pin. For example, PORTC has register names, IOCPx and IOCNx, for these functions. Setting a value of '1' in the IOCPx register enables interrupts for low-to-high transitions, while setting a value of '1' in the IOCNx register enables interrupts for high-to-low transitions. Setting a value of '1' in both register bits will enable interrupts for either case (e.g., a pulse on the pin will generate two interrupts). In order for any IOC to be detected, the global IOC Interrupt Enable bit (IEC1[3]) must be set, the PADCON[15] bit set (IOCON) and the associated ISFx flag cleared.

When an interrupt request is generated for a pin, the corresponding status flag (IOCFx register bit) will be set, indicating that a Change-of-State occurred on that pin. The IOCFx register bit will remain set until cleared by writing a zero to it. When any IOCFx flag bit in a given port is set, the corresponding IOCPxF bit in the IOCSTAT register will be set. This flag indicates that a change was detected on one of the bits on the given port. The IOCPxF flag will be cleared when all IOCFx[15:0] bits are cleared.

Multiple individual status flags can be cleared by writing a zero to one or more bits using a Read-Modify-Write operation. If another edge is detected on a pin whose status bit is being cleared during the Read-Modify-Write sequence, the associated change flag will still be set at the end of the Read-Modify-Write sequence.

The user should use the instruction sequence (or equivalent) shown in [Example 11-1](#) to clear the Interrupt-on-Change Status registers.

At the end of this sequence, the W0 register will contain a zero for each bit for which the port pin had a change detected. In this way, any indication of a pin changing will not be lost.

Due to the asynchronous and real-time nature of the interrupt-on-change, the value read on the port pins may not indicate the state of the port when the change was detected, as a second change can occur during the interval between clearing the flag and reading the port. It is up to the user code to handle this case if it is a possibility in their application. To keep this interval to a minimum, it is recommended that any code modifying the IOCFx registers be run either in the interrupt handler or with interrupts disabled.

Each Interrupt-on-Change (IOC) pin has both a weak pull-up and a weak pull-down connected to it. The pull-ups act as a current source connected to the pin, while the pull-downs act as a current sink connected to the pin. These eliminate the need for external resistors when push button or keypad devices are connected.

The pull-ups and pull-downs are separately enabled using the IOCPx registers (for pull-ups) and the IOCPDx registers (for pull-downs). Each IOC pin has individual control bits for its pull-up and pull-down. Setting a control bit enables the weak pull-up or pull-down for the corresponding pin.

Note: Pull-ups and pull-downs on pins should always be disabled whenever the pin is configured as a digital output.

EXAMPLE 11-1: IOC STATUS READ/CLEAR IN ASSEMBLY

```
MOV    0xFFFF, W0    ; Initial mask value 0xFFFF -> W0
XOR    IOCFx, W0     ; W0 has '1' for each bit set in IOCFx
AND    IOCFx         ; IOCFx & W0 ->IOCFx
```

EXAMPLE 11-2: PORT READ/WRITE IN ASSEMBLY

```
MOV    0xFF00, W0    ; Configure PORTB<15:8> as inputs
MOV    W0, TRISB     ; and PORTB<7:0> as outputs
NOP                    ; Delay 1 cycle
BTSS   PORTB, #13    ; Next Instruction
```

EXAMPLE 11-3: PORT READ/WRITE IN 'C'

```
TRISB = 0xFF00;           // Configure PORTB<15:8> as inputs and PORTB<7:0> as outputs
Nop();                   // Delay 1 cycle
If (PORTBbits.RB13){ };  // Next Instruction
```

11.4 I/O Port Control Registers

REGISTER 11-1: PADCON: PORT CONFIGURATION REGISTER

R/W-0	U-0	U-0	U-0	U-0	U-0	U-0	U-0
IOCON	—	—	—	—	—	—	—
bit 15							bit 8

U-0	U-0	U-0	U-0	U-0	U-0	U-0	R/W-0
—	—	—	—	—	—	—	PMPTTL
bit 7							bit 0

Legend:

R = Readable bit W = Writable bit U = Unimplemented bit, read as '0'
 -n = Value at POR '1' = Bit is set '0' = Bit is cleared x = Bit is unknown

bit 15 **IOCON:** Interrupt-on-Change Enable bit
 1 = Interrupt-on-change functionality is enabled
 0 = Interrupt-on-change functionality is disabled

bit 14-1 **Unimplemented:** Read as '0'

bit 0 **PMPTTL:** PMP Port Type bit
 1 = TTL levels on PMP port pins
 0 = Schmitt Triggers on PMP port pins

REGISTER 11-2: IOCSTAT: INTERRUPT-ON-CHANGE STATUS REGISTER

U-0	U-0	U-0	U-0	U-0	U-0	U-0	U-0
—	—	—	—	—	—	—	—
bit 15							bit 8

U-0	U-0	U-0	U-0	U-0	R/HS/HC-0	R/HS/HC-0	R/HS/HC-0
—	—	—	—	—	IOPCPF	IOCPBF	IOCPAF
bit 7							bit 0

Legend: HS = Hardware Settable bit Hardware Clearable bit
 R = Readable bit W = Writable bit U = Unimplemented bit, read as '0'
 -n = Value at POR '1' = Bit is set '0' = Bit is cleared x = Bit is unknown

bit 15-3 **Unimplemented:** Read as '0'

bit 2 **IOPCPF:** Interrupt-on-Change PORTC Flag bit
 1 = A change was detected on an IOC-enabled pin on PORTC
 0 = No change was detected or the user has cleared all detected changes

bit 1 **IOCPBF:** Interrupt-on-Change PORTB Flag bit
 1 = A change was detected on an IOC-enabled pin on PORTB
 0 = No change was detected or the user has cleared all detected changes

bit 0 **IOCPAF:** Interrupt-on-Change PORTA Flag bit
 1 = A change was detected on an IOC-enabled pin on PORTA
 0 = No change was detected or the user has cleared all detected change

PIC24FJ256GA705 FAMILY

REGISTER 11-5: LATx: OUTPUT DATA FOR PORTx REGISTER⁽¹⁾

R/W-x	R/W-x	R/W-x	R/W-x	R/W-x	R/W-x	R/W-x	R/W-x
LATx[15:8]							
bit 15				bit 8			

R/W-x	R/W-x	R/W-x	R/W-x	R/W-x	R/W-x	R/W-x	R/W-x
LATx[7:0]							
bit 7				bit 0			

Legend:

R = Readable bit W = Writable bit U = Unimplemented bit, read as '0'
 -n = Value at POR '1' = Bit is set '0' = Bit is cleared x = Bit is unknown

bit 15-0 **LATx[15:0]:** PORTx Data Output Value bits

Note 1: See [Table 11-3](#), [Table 11-4](#) and [Table 11-5](#) for individual bit availability in this register.

REGISTER 11-6: ODCx: OPEN-DRAIN ENABLE FOR PORTx REGISTER⁽¹⁾

R/W-0	R/W-0	R/W-0	R/W-0	R/W-0	R/W-0	R/W-0	R/W-0
ODCx[15:8]							
bit 15				bit 8			

R/W-0	R/W-0	R/W-0	R/W-0	R/W-0	R/W-0	R/W-0	R/W-0
ODCx[7:0]							
bit 7				bit 0			

Legend:

R = Readable bit W = Writable bit U = Unimplemented bit, read as '0'
 -n = Value at POR '1' = Bit is set '0' = Bit is cleared x = Bit is unknown

bit 15-0 **ODCx[15:0]:** PORTx Open-Drain Enable bits

- 1 = Open-drain is enabled on the PORTx pin
- 0 = Open-drain is disabled on the PORTx pin

Note 1: See [Table 11-3](#), [Table 11-4](#) and [Table 11-5](#) for individual bit availability in this register.

PIC24FJ256GA705 FAMILY

REGISTER 11-7: ANSELx: ANALOG SELECT FOR PORTx REGISTER⁽¹⁾

R/W-1	R/W-1	R/W-1	R/W-1	R/W-1	R/W-1	R/W-1	R/W-1
ANSELx[15:8]							
bit 15				bit 8			

R/W-1	R/W-1	R/W-1	R/W-1	R/W-1	R/W-1	R/W-1	R/W-1
ANSELx[7:0]							
bit 7				bit 0			

Legend:

R = Readable bit	W = Writable bit	U = Unimplemented bit, read as '0'
-n = Value at POR	'1' = Bit is set	'0' = Bit is cleared x = Bit is unknown

bit 15-0 **ANSELx[15:0]:** Analog Select for PORTx bits

1 = Analog input is enabled and digital input is disabled on the PORTx[n] pin

0 = Analog input is disabled and digital input is enabled on the PORTx[n] pin

Note 1: See [Table 11-3](#), [Table 11-4](#) and [Table 11-5](#) for individual bit availability in this register.

REGISTER 11-8: IOCPx: INTERRUPT-ON-CHANGE POSITIVE EDGE x REGISTER^(1,2,3)

R/W-0	R/W-0	R/W-0	R/W-0	R/W-0	R/W-0	R/W-0	U-0
IOCPx[15:8]							
bit 15							bit 8

R/W-0	R/W-0	R/W-0	R/W-0	R/W-0	R/W-0	R/W-0	R/W-0
IOCPx[7:0]							
bit 7							bit 0

Legend:

R = Readable bit	W = Writable bit	U = Unimplemented bit, read as '0'
-n = Value at POR	'1' = Bit is set	'0' = Bit is cleared x = Bit is unknown

bit 15-0 **IOCPx[15:0]:** Interrupt-on-Change Positive Edge x Enable bits

- 1 = Interrupt-on-change is enabled on the IOCx pin for a positive going edge; the associated status bit and interrupt flag will be set upon detecting an edge
- 0 = Interrupt-on-change is disabled on the IOCx pin for a positive going edge

- Note 1:** Setting both IOCPx and IOCNx will enable the IOCx pin for both edges, while clearing both registers will disable the functionality.
- 2:** Changing the value of this register while the module is enabled (IOCON = 1) may cause a spurious IOC event. The corresponding interrupt must be ignored, cleared (using IOCFx) or masked (within the interrupt controller), or this module must be enabled (IOCON = 0) when changing this register.
- 3:** See [Table 11-3](#), [Table 11-4](#) and [Table 11-5](#) for individual bit availability in this register.

REGISTER 11-9: IOCNx: INTERRUPT-ON-CHANGE NEGATIVE EDGE x REGISTER^(1,2,3)

R/W-0	R/W-0	R/W-0	R/W-0	R/W-0	R/W-0	R/W-0	U-0
IOCNx[15:8]							
bit 15							bit 8

R/W-0	R/W-0	R/W-0	R/W-0	R/W-0	R/W-0	R/W-0	R/W-0
IOCNx[7:0]							
bit 7							bit 0

Legend:

R = Readable bit	W = Writable bit	U = Unimplemented bit, read as '0'
-n = Value at POR	'1' = Bit is set	'0' = Bit is cleared x = Bit is unknown

bit 15-0 **IOCNx[15:0]:** Interrupt-on-Change Negative Edge x Enable bits

- 1 = Interrupt-on-change is enabled on the IOCx pin for a negative going edge; the associated status bit and interrupt flag will be set upon detecting an edge
- 0 = Interrupt-on-change is disabled on the IOCx pin for a negative going edge

- Note 1:** Setting both IOCPx and IOCNx will enable the IOCx pin for both edges, while clearing both registers will disable the functionality.
- 2:** Changing the value of this register while the module is enabled (IOCON = 1) may cause a spurious IOC event. The corresponding interrupt must be ignored, cleared (using IOCFx) or masked (within the interrupt controller), or this module must be enabled (IOCON = 0) when changing this register.
- 3:** See [Table 11-3](#), [Table 11-4](#) and [Table 11-5](#) for individual bit availability in this register.

PIC24FJ256GA705 FAMILY

REGISTER 11-10: IOCFx: INTERRUPT-ON-CHANGE FLAG x REGISTER^(1,2)

R/W-0	R/W-0	R/W-0	R/W-0	R/W-0	R/W-0	R/W-0	U-0
IOCFx[15:8]							
bit 15							bit 8

R/W-0	R/W-0	R/W-0	R/W-0	R/W-0	R/W-0	R/W-0	R/W-0
IOCFx[7:0]							
bit 7							bit 0

Legend:

R = Readable bit W = Writable bit U = Unimplemented bit, read as '0'
 -n = Value at POR '1' = Bit is set '0' = Bit is cleared x = Bit is unknown

bit 15-0 **IOCFx[15:0]:** Interrupt-on-Change Flag x bits
 1 = An enabled change was detected on the associated pin; set when IOCPx = 1 and a positive edge was detected on the IOCx pin or when IOCNx = 1 and a negative edge was detected on the IOCx pin
 0 = No change was detected or the user cleared the detected change

Note 1: It is not possible to set the IOCFx register bits with software writes (as this would require the addition of significant logic). To test IOC interrupts, it is recommended to enable the IOC functionality on one or more GPIO pins and then use the corresponding LATx register bit(s) to trigger an IOC interrupt.

2: See [Table 11-3](#), [Table 11-4](#) and [Table 11-5](#) for individual bit availability in this register.

REGISTER 11-11: IOCPUx: INTERRUPT-ON-CHANGE PULL-UP ENABLE x REGISTER⁽¹⁾

R/W-0	R/W-0	R/W-0	R/W-0	R/W-0	R/W-0	R/W-0	U-0
IOCPUx[15:8]							
bit 15							bit 8

R/W-0	R/W-0	R/W-0	R/W-0	R/W-0	R/W-0	R/W-0	R/W-0
IOCPUx[7:0]							
bit 7							bit 0

Legend:

R = Readable bit W = Writable bit U = Unimplemented bit, read as '0'
 -n = Value at POR '1' = Bit is set '0' = Bit is cleared x = Bit is unknown

bit 15-0 **IOCPUx[15:0]:** Interrupt-on-Change Pull-up Enable x bits
 1 = Pull-up is enabled
 0 = Pull-up is disabled

Note 1: See [Table 11-3](#), [Table 11-4](#) and [Table 11-5](#) for individual bit availability in this register.

PIC24FJ256GA705 FAMILY

REGISTER 11-12: IOCPDx: INTERRUPT-ON-CHANGE PULL-DOWN ENABLE x REGISTER⁽¹⁾

R/W-0	R/W-0	R/W-0	R/W-0	R/W-0	R/W-0	R/W-0	U-0
IOCPDx[15:8]							
bit 15							bit 8

R/W-0	R/W-0	R/W-0	R/W-0	R/W-0	R/W-0	R/W-0	R/W-0
IOCPDx[7:0]							
bit 7							bit 0

Legend:

R = Readable bit

W = Writable bit

U = Unimplemented bit, read as '0'

-n = Value at POR

'1' = Bit is set

'0' = Bit is cleared

x = Bit is unknown

bit 15-0 **IOCPDx[15:0]:** Interrupt-on-Change Pull-Down Enable x bits

1 = Pull-down is enabled

0 = Pull-down is disabled

Note 1: See [Table 11-3](#), [Table 11-4](#) and [Table 11-5](#) for individual bit availability in this register.

PIC24FJ256GA705 FAMILY

11.5 Peripheral Pin Select (PPS)

A major challenge in general purpose devices is providing the largest possible set of peripheral features while minimizing the conflict of features on I/O pins. In an application that needs to use more than one peripheral multiplexed on a single pin, inconvenient work arounds in application code, or a complete redesign, may be the only option.

The Peripheral Pin Select (PPS) feature provides an alternative to these choices by enabling the user's peripheral set selection and its placement on a wide range of I/O pins. By increasing the pinout options available on a particular device, users can better tailor the microcontroller to their entire application, rather than trimming the application to fit the device.

The Peripheral Pin Select feature operates over a fixed subset of digital I/O pins. Users may independently map the input and/or output of any one of many digital peripherals to any one of these I/O pins. PPS is performed in software and generally does not require the device to be reprogrammed. Hardware safeguards are included that prevent accidental or spurious changes to the peripheral mapping once it has been established.

11.5.1 AVAILABLE PINS

The PPS feature is used with a range of up to 44 pins, depending on the particular device and its pin count. Pins that support the Peripheral Pin Select feature include the designation, "RPn" or "RPI n", in their full pin designation, where "n" is the remappable pin number. "RP" is used to designate pins that support both remappable input and output functions, while "RPI" indicates pins that support remappable input functions only.

PIC24FJ256GA705 family devices support a larger number of remappable input/output pins than remappable input only pins. In this device family, there are up to 33 remappable input/output pins, depending on the pin count of the particular device selected. These pins are numbered, RP0 through RP28 and RPI29 through RPI32.

See [Table 1-1](#) for a summary of pinout options in each package offering.

11.5.2 AVAILABLE PERIPHERALS

The peripherals managed by the PPS are all digital only peripherals. These include general serial communications (UART and SPI), general purpose timer clock inputs, timer related peripherals (input capture and output compare) and external interrupt inputs. Also included are the outputs of the comparator module, since these are discrete digital signals.

PPS is not available for these peripherals:

- I²C (input and output)
- Input Change Notifications
- EPMP Signals (input and output)
- Analog (inputs and outputs)
- INT0

A key difference between pin select and non-pin select peripherals is that pin select peripherals are not associated with a default I/O pin. The peripheral must always be assigned to a specific I/O pin before it can be used. In contrast, non-pin select peripherals are always available on a default pin, assuming that the peripheral is active and not conflicting with another peripheral.

11.5.2.1 Peripheral Pin Select Function Priority

Pin-selectable peripheral outputs (e.g., output compare, UART transmit) will take priority over general purpose digital functions on a pin, such as EPMP and port I/O. Specialized digital outputs will take priority over PPS outputs on the same pin. The pin diagrams list peripheral outputs in the order of priority. Refer to them for priority concerns on a particular pin.

Unlike PIC24F devices with fixed peripherals, pin-selectable peripheral inputs will never take ownership of a pin. The pin's output buffer will be controlled by the TRISx setting or by a fixed peripheral on the pin. If the pin is configured in Digital mode, then the PPS input will operate correctly. If an analog function is enabled on the pin, the PPS input will be disabled.

11.5.3 CONTROLLING PERIPHERAL PIN SELECT

PPS features are controlled through two sets of Special Function Registers (SFRs): one to map peripheral inputs and one to map outputs. Because they are separately controlled, a particular peripheral's input and output (if the peripheral has both) can be placed on any selectable function pin without constraint.

The association of a peripheral to a peripheral-selectable pin is handled in two different ways, depending on if an input or an output is being mapped.

PIC24FJ256GA705 FAMILY

11.5.3.1 Input Mapping

The inputs of the Peripheral Pin Select options are mapped on the basis of the peripheral; that is, a control register associated with a peripheral dictates the pin it will be mapped to. The RPINRx registers are used to configure peripheral input mapping (see [Register 11-13](#) through [Register 11-31](#)).

Each register contains one or two sets of 6-bit fields, with each set associated with one of the pin-selectable peripherals. Programming a given peripheral's bit field with an appropriate 6-bit value maps the RPN/RPIn pin with that value to that peripheral. For any given device, the valid range of values for any of the bit fields corresponds to the maximum number of Peripheral Pin Selections supported by the device.

TABLE 11-6: SELECTABLE INPUT SOURCES (MAPS INPUT TO FUNCTION)⁽¹⁾

Input Name	Function Name	Register	Function Mapping Bits
Output Compare Trigger 1	OCTRIG1	RPINR0[5:0]	OCTRIG1R[5:0]
External Interrupt 1	INT1	RPINR0[13:8]	INT1R[5:0]
External Interrupt 2	INT2	RPINR1[5:0]	INT2R[5:0]
External Interrupt 3	INT3	RPINR1[13:8]	INT3R[5:0]
External Interrupt 4	INT4	RPINR2[5:0]	INT4R[5:0]
Output Compare Trigger 2	OCTRIG2	RPINR2[13:8]	OCTRIG2R[5:0]
Timer2 External Clock	T2CK	RPINR3[5:0]	T2CKR[5:0]
Timer3 External Clock	T3CK	RPINR3[13:8]	T3CKR[5:0]
Input Capture Mode 1	ICM1	RPINR5[5:0]	ICM1R[5:0]
Input Capture Mode 2	ICM2	RPINR5[13:8]	ICM2R[5:0]
Input Capture Mode 3	ICM3	RPINR6[5:0]	ICM3R[5:0]
Input Capture Mode 4	ICM4	RPINR6[13:8]	ICM4R[5:0]
Input Capture 1	IC1	RPINR7[5:0]	IC1R[5:0]
Input Capture 2	IC2	RPINR7[13:8]	IC2R[5:0]
Input Capture 3	IC3	RPINR8[5:0]	IC3R[5:0]
Output Compare Fault A	OCFA	RPINR11[5:0]	OCFAR[5:0]
Output Compare Fault B	OCFB	RPINR11[13:8]	OCFBR[5:0]
CCP Clock Input A	TCKIA	RPINR12[5:0]	TCKIAR[5:0]
CCP Clock Input B	TCKIB	RPINR12[13:8]	TCKIBR[5:0]
UART1 Receive	U1RX	RPINR18[5:0]	U1RXR[5:0]
UART1 Clear-to-Send	$\overline{U1CTS}$	RPINR18[13:8]	U1CTSR[5:0]
UART2 Receive	U2RX	RPINR19[5:0]	U2RXR[5:0]
UART2 Clear-to-Send	$\overline{U2CTS}$	RPINR19[13:8]	U2CTSR[5:0]
SPI1 Data Input	SDI1	RPINR20[5:0]	SDI1R[5:0]
SPI1 Clock Input	SCK1IN	RPINR20[13:8]	SCK1R[5:0]
SPI1 Slave Select Input	SS1IN	RPINR21[5:0]	SS1R[5:0]
SPI2 Data Input	SDI2	RPINR22[5:0]	SDI2R[5:0]
SPI2 Clock Input	SCK2IN	RPINR22[13:8]	SCK2R[5:0]
SPI2 Slave Select Input	SS2IN	RPINR23[5:0]	SS2R[5:0]
Generic Timer External Clock	TxCK	RPINR23[13:8]	TXCKR[5:0]
CLC Input A	CLCINA	RPINR25[5:0]	CLCINAR[5:0]
CLC Input B	CLCINB	RPINR25[13:8]	CLCINBR[5:0]
SPI3 Data Input	SDI3	RPINR28[5:0]	SDI3R[5:0]
SPI3 Clock Input	SCK3IN	RPINR28[13:8]	SCK3R[5:0]
SPI3 Slave Select Input	SS3IN	RPINR29[5:0]	SS3R[5:0]

Note 1: Unless otherwise noted, all inputs use the Schmitt Trigger (ST) input buffers.

PIC24FJ256GA705 FAMILY

11.5.3.2 Output Mapping

In contrast to inputs, the outputs of the Peripheral Pin Select options are mapped on the basis of the pin. In this case, a control register associated with a particular pin dictates the peripheral output to be mapped. The RPORx registers are used to control output mapping. Each register contains two 6-bit fields, with each field being associated with one RPn pin (see [Register 11-32](#) through [Register 11-46](#)). The value of the bit field

corresponds to one of the peripherals and that peripheral's output is mapped to the pin (see [Table 11-7](#)).

Because of the mapping technique, the list of peripherals for output mapping also includes a null value of '000000'. This permits any given pin to remain disconnected from the output of any of the pin-selectable peripherals.

TABLE 11-7: SELECTABLE OUTPUT SOURCES (MAPS FUNCTION TO OUTPUT)

Output Function Number	Function	Output Name
0	None (Pin Disabled)	—
1	C1OUT	Comparator 1 Output
2	C2OUT	Comparator 2 Output
3	U1TX	UART1 Transmit
4	U1RTS	UART1 Request-to-Send
5	U2TX	UART2 Transmit
6	U2RTS	UART2 Request-to-Send
7	SDO1	SPI1 Data Output
8	SCK1OUT	SPI1 Clock Output
9	SS1OUT	SPI1 Slave Select Output
10	SDO2	SPI2 Data Output
11	SCK2OUT	SPI2 Clock Output
12	SS2OUT	SPI2 Slave Select Output
13	OC1	Output Compare 1
14	OC2	Output Compare 2
15	OC3	Output Compare 3
16	OCM2A	CCP2A Output Compare
17	OCM2B	CCP2B Output Compare
18	OCM3A	CCP3A Output Compare
19	OCM3B	CCP3B Output Compare
20	OCM4A	CCP4A Output Compare
21	OCM4B	CCP4B Output Compare
22	Reserved	—
23	SDO3	SPI3 Data Output
24	SCK3OUT	SPI3 Clock Output
25	SS3OUT	SPI3 Slave Select Output
26	C3OUT	Comparator 3 Output
27	PWRGT	RTCC Power Control
28	REFO	Reference Clock Output
29	CLC1OUT	CLC1 Output
30	CLC2OUT	CLC2 Output
31	RTCC	RTCC Clock Output

11.5.3.3 Mapping Limitations

The control schema of the Peripheral Pin Select is extremely flexible. Other than systematic blocks that prevent signal contention, caused by two physical pins being configured as the same functional input or two functional outputs configured as the same pin, there are no hardware enforced lockouts. The flexibility extends to the point of allowing a single input to drive multiple peripherals or a single functional output to drive multiple output pins.

11.5.3.4 Mapping Exceptions for Family Devices

The differences in available remappable pins are summarized in [Table 11-8](#).

When developing applications that use remappable pins, users should also keep these things in mind:

- For the RPINRx registers, bit combinations corresponding to an unimplemented pin for a particular device are treated as invalid; the corresponding module will not have an input mapped to it.
- For RPORx registers, the bit fields corresponding to an unimplemented pin will also be unimplemented; writing to these fields will have no effect.

11.5.4 CONTROLLING CONFIGURATION CHANGES

Because peripheral remapping can be changed during run time, some restrictions on peripheral remapping are needed to prevent accidental configuration changes. PIC24F devices include three features to prevent alterations to the peripheral map:

- Control register lock sequence
- Continuous state monitoring
- Configuration bit remapping lock

11.5.4.1 Control Register Lock

Under normal operation, writes to the RPINRx and RPORx registers are not allowed. Attempted writes will appear to execute normally, but the contents of the

registers will remain unchanged. To change these registers, they must be unlocked in hardware. The register lock is controlled by the IOLOCK bit (OSCCON[6]). Setting IOLOCK prevents writes to the control registers; clearing IOLOCK allows writes.

To set or clear IOLOCK, a specific command sequence must be executed:

1. Write 46h to OSCCON[7:0].
2. Write 57h to OSCCON[7:0].
3. Clear (or set) IOLOCK as a single operation.

Unlike the similar sequence with the oscillator's LOCK bit, IOLOCK remains in one state until changed. This allows all of the Peripheral Pin Selects to be configured with a single unlock sequence, followed by an update to all control registers, then locked with a second lock sequence.

11.5.4.2 Continuous State Monitoring

In addition to being protected from direct writes, the contents of the RPINRx and RPORx registers are constantly monitored in hardware by shadow registers. If an unexpected change in any of the registers occurs (such as cell disturbances caused by ESD or other external events), a Configuration Mismatch Reset will be triggered.

11.5.4.3 Configuration Bit Pin Select Lock

As an additional level of safety, the device can be configured to prevent more than one write session to the RPINRx and RPORx registers. The IOL1WAY (FOSC[5]) Configuration bit blocks the IOLOCK bit from being cleared after it has been set once. If IOLOCK remains set, the register unlock procedure will not execute and the Peripheral Pin Select Control registers cannot be written to. The only way to clear the bit and re-enable peripheral remapping is to perform a device Reset.

In the Default (unprogrammed) state, IOL1WAY is set, restricting users to one write session. Programming IOL1WAY allows users unlimited access (with the proper use of the unlock sequence) to the Peripheral Pin Select registers.

TABLE 11-8: REMAPPABLE PIN EXCEPTIONS FOR PIC24FJ256GA705 FAMILY DEVICES

Device	RPn Pins (I/O)		RPIn Pins	
	Total	Unimplemented	Total	Unimplemented
PIC24FJXXXGA705	29	—	4	—
PIC24FJXXXGA704	29	—	0	RPI29-32
PIC24FJXXXGA702	18	RP16-25	0	RPI29-32

PIC24FJ256GA705 FAMILY

11.5.5 CONSIDERATIONS FOR PERIPHERAL PIN SELECTION

The ability to control Peripheral Pin Selection introduces several considerations into application design that could be overlooked. This is particularly true for several common peripherals that are available only as remappable peripherals.

The main consideration is that the Peripheral Pin Selects are not available on default pins in the device's Default (Reset) state. Since all RPINRx registers reset to '111111' and all RPORx registers reset to '000000', all Peripheral Pin Select inputs are tied to Vss, and all Peripheral Pin Select outputs are disconnected.

This situation requires the user to initialize the device with the proper peripheral configuration before any other application code is executed. Since the IOLOCK bit resets in the Unlocked state, it is not necessary to execute the unlock sequence after the device has come out of Reset. For application safety, however, it is best to set IOLOCK and lock the configuration after writing to the control registers.

Because the unlock sequence is timing-critical, it must be executed as an assembly language routine in the same manner as changes to the oscillator configuration. If the bulk of the application is written in 'C', or another high-level language, the unlock sequence should be performed by writing in-line assembly.

Choosing the configuration requires the review of all Peripheral Pin Selects and their pin assignments, especially those that will not be used in the application. In all cases, unused pin-selectable peripherals should be disabled completely. Unused peripherals should have their inputs assigned to an unused RPN/RPn pin function. I/O pins with unused RPn functions should be configured with the null peripheral output.

The assignment of a peripheral to a particular pin does not automatically perform any other configuration of the pin's I/O circuitry. In theory, this means adding a pin-selectable output to a pin may mean inadvertently driving an existing peripheral input when the output is driven. Users must be familiar with the behavior of other fixed peripherals that share a remappable pin and know when to enable or disable them. To be safe, fixed digital peripherals that share the same pin should be disabled when not in use.

Along these lines, configuring a remappable pin for a specific peripheral does not automatically turn that feature on. The peripheral must be specifically configured for operation and enabled as if it were tied to a fixed pin. Where this happens in the application code (immediately following a device Reset and peripheral configuration or inside the main application routine) depends on the peripheral and its use in the application.

A final consideration is that Peripheral Pin Select functions neither override analog inputs nor reconfigure pins with analog functions for digital I/Os. If a pin is configured as an analog input on a device Reset, it must be explicitly reconfigured as a digital I/O when used with a Peripheral Pin Select.

Example 11-4 shows a configuration for bidirectional communication with flow control using UART1. The following input and output functions are used:

- Input Functions: U1RX, U1CTS
- Output Functions: U1TX, U1RTS

EXAMPLE 11-4: CONFIGURING UART1 INPUT AND OUTPUT FUNCTIONS

```
// Unlock Registers
asm volatile ("MOV #OSCCON, w1 \n"
             "MOV #0x46, w2 \n"
             "MOV #0x57, w3 \n"
             "MOV.b w2, [w1] \n"
             "MOV.b w3, [w1] \n"
             "BCLR OSCCON, #6") ;

// or use XC16 built-in macro:
// __builtin_write_OSCCONL(OSCCON & 0xbf);

// Configure Input Functions (Table 11-6)
// Assign U1RX To Pin RP0
RPINR18bits.U1RXR = 0;

// Assign U1CTS To Pin RP1
RPINR18bits.U1CTSR = 1;

// Configure Output Functions (Table 11-7)
// Assign U1TX To Pin RP2
RPOR1bits.RP2R = 3;

// Assign U1RTS To Pin RP3
RPOR1bits.RP3R = 4;

// Lock Registers
asm volatile ("MOV #OSCCON, w1 \n"
             "MOV #0x46, w2 \n"
             "MOV #0x57, w3 \n"
             "MOV.b w2, [w1] \n"
             "MOV.b w3, [w1] \n"
             "BSET OSCCON, #6") ;

// or use XC16 built-in macro:
// __builtin_write_OSCCONL(OSCCON | 0x40);
```

11.5.6 PERIPHERAL PIN SELECT REGISTERS

The PIC24FJ256GA705 family of devices implements a total of 34 registers for remappable peripheral configuration:

- Input Remappable Peripheral Registers (19)
- Output Remappable Peripheral Registers (15)

Note: Input and Output register values can only be changed if IOLOCK (OSCCON[6]) = 0. See [Section 11.5.4.1 “Control Register Lock”](#) for a specific command sequence.

REGISTER 11-13: RPINR0: PERIPHERAL PIN SELECT INPUT REGISTER 0

U-0	U-0	R/W-1	R/W-1	R/W-1	R/W-1	R/W-1	R/W-1
—	—	INT1R5	INT1R4	INT1R3	INT1R2	INT1R1	INT1R0
bit 15							bit 8

U-0	U-0	R/W-1	R/W-1	R/W-1	R/W-1	R/W-1	R/W-1
—	—	OCTRIG1R5	OCTRIG1R4	OCTRIG1R3	OCTRIG1R2	OCTRIG1R1	OCTRIG1R0
bit 7							bit 0

Legend:

R = Readable bit W = Writable bit U = Unimplemented bit, read as '0'
 -n = Value at POR '1' = Bit is set '0' = Bit is cleared x = Bit is unknown

- bit 15-14 **Unimplemented:** Read as '0'
- bit 13-8 **INT1R[5:0]:** Assign External Interrupt 1 (INT1) to Corresponding RPN or RPN Pin bits
- bit 7-6 **Unimplemented:** Read as '0'
- bit 5-0 **OCTRIG1R[5:0]:** Assign Output Compare Trigger 1 (OCTRIG1) to Corresponding RPN or RPN Pin bits

REGISTER 11-14: RPINR1: PERIPHERAL PIN SELECT INPUT REGISTER 1

U-0	U-0	R/W-1	R/W-1	R/W-1	R/W-1	R/W-1	R/W-1
—	—	INT3R5	INT3R4	INT3R3	INT3R2	INT3R1	INT3R0
bit 15							bit 8

U-0	U-0	R/W-1	R/W-1	R/W-1	R/W-1	R/W-1	R/W-1
—	—	INT2R5	INT2R4	INT2R3	INT2R2	INT2R1	INT2R0
bit 7							bit 0

Legend:

R = Readable bit W = Writable bit U = Unimplemented bit, read as '0'
 -n = Value at POR '1' = Bit is set '0' = Bit is cleared x = Bit is unknown

- bit 15-14 **Unimplemented:** Read as '0'
- bit 13-8 **INT3R[5:0]:** Assign External Interrupt 3 (INT3) to Corresponding RPN or RPN Pin bits
- bit 7-6 **Unimplemented:** Read as '0'
- bit 5-0 **INT2R[5:0]:** Assign External Interrupt 2 (INT2) to Corresponding RPN or RPN Pin bits

PIC24FJ256GA705 FAMILY

REGISTER 11-15: RPINR2: PERIPHERAL PIN SELECT INPUT REGISTER 2

U-0	U-0	R/W-1	R/W-1	R/W-1	R/W-1	R/W-1	R/W-1
—	—	OCTRIG2R5	OCTRIG2R4	OCTRIG2R3	OCTRIG2R2	OCTRIG2R1	OCTRIG2R0
bit 15							bit 8

U-0	U-0	R/W-1	R/W-1	R/W-1	R/W-1	R/W-1	R/W-1
—	—	INT4R5	INT4R4	INT4R3	INT4R2	INT4R1	INT4R0
bit 7							bit 0

Legend:

R = Readable bit W = Writable bit U = Unimplemented bit, read as '0'
 -n = Value at POR '1' = Bit is set '0' = Bit is cleared x = Bit is unknown

- bit 15-14 **Unimplemented:** Read as '0'
- bit 13-8 **OCTRIG2R[5:0]:** Assign Output Compare Trigger 2 (OCTRIG2) to Corresponding RPn or RPIIn Pin bits
- bit 7-6 **Unimplemented:** Read as '0'
- bit 5-0 **INT4R[5:0]:** Assign External Interrupt 4 (INT4) to Corresponding RPn or RPIIn Pin bits

REGISTER 11-16: RPINR3: PERIPHERAL PIN SELECT INPUT REGISTER 3

U-0	U-0	R/W-1	R/W-1	R/W-1	R/W-1	R/W-1	R/W-1
—	—	T3CKR5	T3CKR4	T3CKR3	T3CKR2	T3CKR1	T3CKR0
bit 15							bit 8

U-0	U-0	R/W-1	R/W-1	R/W-1	R/W-1	R/W-1	R/W-1
—	—	T2CKR5	T2CKR4	T2CKR3	T2CKR2	T2CKR1	T2CKR0
bit 7							bit 0

Legend:

R = Readable bit W = Writable bit U = Unimplemented bit, read as '0'
 -n = Value at POR '1' = Bit is set '0' = Bit is cleared x = Bit is unknown

- bit 15-14 **Unimplemented:** Read as '0'
- bit 13-8 **T3CKR[5:0]:** Assign Timer3 Clock (T3CK) to Corresponding RPn or RPIIn Pin bits
- bit 7-6 **Unimplemented:** Read as '0'
- bit 5-0 **T2CKR[5:0]:** Assign Timer2 Clock (T2CK) to Corresponding RPn or RPIIn Pin bits

PIC24FJ256GA705 FAMILY

REGISTER 11-17: RPINR5: PERIPHERAL PIN SELECT INPUT REGISTER 5

U-0	U-0	R/W-1	R/W-1	R/W-1	R/W-1	R/W-1	R/W-1
—	—	ICM2R5	ICM2R4	ICM2R3	ICM2R2	ICM2R1	ICM2R0
bit 15							bit 8

U-0	U-0	R/W-1	R/W-1	R/W-1	R/W-1	R/W-1	R/W-1
—	—	ICM1R5	ICM1R4	ICM1R3	ICM1R2	ICM1R1	ICM1R0
bit 7							bit 0

Legend:

R = Readable bit W = Writable bit U = Unimplemented bit, read as '0'
 -n = Value at POR '1' = Bit is set '0' = Bit is cleared x = Bit is unknown

- bit 15-14 **Unimplemented:** Read as '0'
- bit 13-8 **ICM2R[5:0]:** Assign Input Capture Mode 2 (ICM2) to Corresponding RPn or RPIn Pin bits
- bit 7-6 **Unimplemented:** Read as '0'
- bit 5-0 **ICM1R[5:0]:** Assign Input Capture Mode 1 (ICM1) to Corresponding RPn or RPIn Pin bits

REGISTER 11-18: RPINR6: PERIPHERAL PIN SELECT INPUT REGISTER 6

U-0	U-0	R/W-1	R/W-1	R/W-1	R/W-1	R/W-1	R/W-1
—	—	ICM4R5	ICM4R4	ICM4R3	ICM4R2	ICM4R1	ICM4R0
bit 15							bit 8

U-0	U-0	R/W-1	R/W-1	R/W-1	R/W-1	R/W-1	R/W-1
—	—	ICM3R5	ICM3R4	ICM3R3	ICM3R2	ICM3R1	ICM3R0
bit 7							bit 0

Legend:

R = Readable bit W = Writable bit U = Unimplemented bit, read as '0'
 -n = Value at POR '1' = Bit is set '0' = Bit is cleared x = Bit is unknown

- bit 15-14 **Unimplemented:** Read as '0'
- bit 13-8 **ICM4R[5:0]:** Assign Input Capture Mode 4 (ICM4) to Corresponding RPn or RPIn Pin bits
- bit 7-6 **Unimplemented:** Read as '0'
- bit 5-0 **ICM3R[5:0]:** Assign Input Capture Mode 3 (ICM3) to Corresponding RPn or RPIn Pin bits

PIC24FJ256GA705 FAMILY

REGISTER 11-19: RPINR7: PERIPHERAL PIN SELECT INPUT REGISTER 7

U-0	U-0	R/W-1	R/W-1	R/W-1	R/W-1	R/W-1	R/W-1
—	—	IC2R5	IC2R4	IC2R3	IC2R2	IC2R1	IC2R0
bit 15							bit 8

U-0	U-0	R/W-1	R/W-1	R/W-1	R/W-1	R/W-1	R/W-1
—	—	IC1R5	IC1R4	IC1R3	IC1R2	IC1R1	IC1R0
bit 7							bit 0

Legend:

R = Readable bit W = Writable bit U = Unimplemented bit, read as '0'
 -n = Value at POR '1' = Bit is set '0' = Bit is cleared x = Bit is unknown

- bit 15-14 **Unimplemented:** Read as '0'
- bit 13-8 **IC2R[5:0]:** Assign Input Capture 2 (IC2) to Corresponding RPn or RPIn Pin bits
- bit 7-6 **Unimplemented:** Read as '0'
- bit 5-0 **IC1R[5:0]:** Assign Input Capture 1 (IC1) to Corresponding RPn or RPIn Pin bits

REGISTER 11-20: RPINR8: PERIPHERAL PIN SELECT INPUT REGISTER 8

U-0	U-0	U-0	U-0	U-0	U-0	U-0	U-0
—	—	—	—	—	—	—	—
bit 15							bit 8

U-0	U-0	R/W-1	R/W-1	R/W-1	R/W-1	R/W-1	R/W-1
—	—	IC3R5	IC3R4	IC3R3	IC3R2	IC3R1	IC3R0
bit 7							bit 0

Legend:

R = Readable bit W = Writable bit U = Unimplemented bit, read as '0'
 -n = Value at POR '1' = Bit is set '0' = Bit is cleared x = Bit is unknown

- bit 15-6 **Unimplemented:** Read as '0'
- bit 5-0 **IC3R[5:0]:** Assign Input Capture 3 (IC3) to Corresponding RPn or RPIn Pin bits

PIC24FJ256GA705 FAMILY

REGISTER 11-21: RPINR11: PERIPHERAL PIN SELECT INPUT REGISTER 11

U-0	U-0	R/W-1	R/W-1	R/W-1	R/W-1	R/W-1	R/W-1
—	—	OCFBR5	OCFBR4	OCFBR3	OCFBR2	OCFBR1	OCFBR0
bit 15							bit 8

U-0	U-0	R/W-1	R/W-1	R/W-1	R/W-1	R/W-1	R/W-1
—	—	OCFAR5	OCFAR4	OCFAR3	OCFAR2	OCFAR1	OCFAR0
bit 7							bit 0

Legend:

R = Readable bit W = Writable bit U = Unimplemented bit, read as '0'
 -n = Value at POR '1' = Bit is set '0' = Bit is cleared x = Bit is unknown

- bit 15-14 **Unimplemented:** Read as '0'
- bit 13-8 **OCFBR[5:0]:** Assign Output Compare Fault B (OCFB) to Corresponding RPn or RPIIn Pin bits
- bit 7-6 **Unimplemented:** Read as '0'
- bit 5-0 **OCFAR[5:0]:** Assign Output Compare Fault A (OCFA) to Corresponding RPn or RPIIn Pin bits

REGISTER 11-22: RPINR12: PERIPHERAL PIN SELECT INPUT REGISTER 12

U-0	U-0	R/W-1	R/W-1	R/W-1	R/W-1	R/W-1	R/W-1
—	—	TCKIBR5	TCKIBR4	TCKIBR3	TCKIBR2	TCKIBR1	TCKIBR0
bit 15							bit 8

U-0	U-0	R/W-1	R/W-1	R/W-1	R/W-1	R/W-1	R/W-1
—	—	TCKIAR5	TCKIAR4	TCKIAR3	TCKIAR2	TCKIAR1	TCKIAR0
bit 7							bit 0

Legend:

R = Readable bit W = Writable bit U = Unimplemented bit, read as '0'
 -n = Value at POR '1' = Bit is set '0' = Bit is cleared x = Bit is unknown

- bit 15-14 **Unimplemented:** Read as '0'
- bit 13-8 **TCKIBR[5:0]:** Assign MCCP/SCCP Clock Input B (TCKIB) to Corresponding RPn or RPIIn Pin bits
- bit 7-6 **Unimplemented:** Read as '0'
- bit 5-0 **TCKIAR[5:0]:** Assign MCCP/SCCP Clock Input A (TCKIA) to Corresponding RPn or RPIIn Pin bits

PIC24FJ256GA705 FAMILY

REGISTER 11-23: RPINR18: PERIPHERAL PIN SELECT INPUT REGISTER 18

U-0	U-0	R/W-1	R/W-1	R/W-1	R/W-1	R/W-1	R/W-1
—	—	U1CTSR5	U1CTSR4	U1CTSR3	U1CTSR2	U1CTSR1	U1CTSR0
bit 15							bit 8

U-0	U-0	R/W-1	R/W-1	R/W-1	R/W-1	R/W-1	R/W-1
—	—	U1RXR5	U1RXR4	U1RXR3	U1RXR2	U1RXR1	U1RXR0
bit 7							bit 0

Legend:

R = Readable bit

W = Writable bit

U = Unimplemented bit, read as '0'

-n = Value at POR

'1' = Bit is set

'0' = Bit is cleared

x = Bit is unknown

bit 15-14 **Unimplemented:** Read as '0'

bit 13-8 **U1CTSR[5:0]:** Assign UART1 Clear-to-Send ($\overline{U1CTS}$) to Corresponding RPn or RPIn Pin bits

bit 7-6 **Unimplemented:** Read as '0'

bit 5-0 **U1RXR[5:0]:** Assign UART1 Receive (U1RX) to Corresponding RPn or RPIn Pin bits

REGISTER 11-24: RPINR19: PERIPHERAL PIN SELECT INPUT REGISTER 19

U-0	U-0	R/W-1	R/W-1	R/W-1	R/W-1	R/W-1	R/W-1
—	—	U2CTSR5	U2CTSR4	U2CTSR3	U2CTSR2	U2CTSR1	U2CTSR0
bit 15							bit 8

U-0	U-0	R/W-1	R/W-1	R/W-1	R/W-1	R/W-1	R/W-1
—	—	U2RXR5	U2RXR4	U2RXR3	U2RXR2	U2RXR1	U2RXR0
bit 7							bit 0

Legend:

R = Readable bit

W = Writable bit

U = Unimplemented bit, read as '0'

-n = Value at POR

'1' = Bit is set

'0' = Bit is cleared

x = Bit is unknown

bit 15-14 **Unimplemented:** Read as '0'

bit 13-8 **U2CTSR[5:0]:** Assign UART2 Clear-to-Send ($\overline{U2CTS}$) to Corresponding RPn or RPIn Pin bits

bit 7-6 **Unimplemented:** Read as '0'

bit 5-0 **U2RXR[5:0]:** Assign UART2 Receive (U2RX) to Corresponding RPn or RPIn Pin bits

PIC24FJ256GA705 FAMILY

REGISTER 11-25: RPINR20: PERIPHERAL PIN SELECT INPUT REGISTER 20

U-0	U-0	R/W-1	R/W-1	R/W-1	R/W-1	R/W-1	R/W-1
—	—	SCK1R5	SCK1R4	SCK1R3	SCK1R2	SCK1R1	SCK1R0
bit 15							bit 8

U-0	U-0	R/W-1	R/W-1	R/W-1	R/W-1	R/W-1	R/W-1
—	—	SDI1R5	SDI1R4	SDI1R3	SDI1R2	SDI1R1	SDI1R0
bit 7							bit 0

Legend:

R = Readable bit W = Writable bit U = Unimplemented bit, read as '0'
 -n = Value at POR '1' = Bit is set '0' = Bit is cleared x = Bit is unknown

- bit 15-14 **Unimplemented:** Read as '0'
- bit 13-8 **SCK1R[5:0]:** Assign SPI1 Clock Input (SCK1IN) to Corresponding RPn or RPIIn Pin bits
- bit 7-6 **Unimplemented:** Read as '0'
- bit 5-0 **SDI1R[5:0]:** Assign SPI1 Data Input (SDI1) to Corresponding RPn or RPIIn Pin bits

REGISTER 11-26: RPINR21: PERIPHERAL PIN SELECT INPUT REGISTER 21

U-0	U-0	U-0	U-0	U-0	U-0	U-0	U-0
—	—	—	—	—	—	—	—
bit 15							bit 8

U-0	U-0	R/W-1	R/W-1	R/W-1	R/W-1	R/W-1	R/W-1
—	—	SS1R5	SS1R4	SS1R3	SS1R2	SS1R1	SS1R0
bit 7							bit 0

Legend:

R = Readable bit W = Writable bit U = Unimplemented bit, read as '0'
 -n = Value at POR '1' = Bit is set '0' = Bit is cleared x = Bit is unknown

- bit 15-6 **Unimplemented:** Read as '0'
- bit 5-0 **SS1R[5:0]:** Assign SPI1 Slave Select Input (SS1IN) to Corresponding RPn or RPIIn Pin bits

PIC24FJ256GA705 FAMILY

REGISTER 11-27: RPINR22: PERIPHERAL PIN SELECT INPUT REGISTER 22

U-0	U-0	R/W-1	R/W-1	R/W-1	R/W-1	R/W-1	R/W-1
—	—	SCK2R5	SCK2R4	SCK2R3	SCK2R2	SCK2R1	SCK2R0
bit 15							bit 8

U-0	U-0	R/W-1	R/W-1	R/W-1	R/W-1	R/W-1	R/W-1
—	—	SDI2R5	SDI2R4	SDI2R3	SDI2R2	SDI2R1	SDI2R0
bit 7							bit 0

Legend:

R = Readable bit W = Writable bit U = Unimplemented bit, read as '0'
 -n = Value at POR '1' = Bit is set '0' = Bit is cleared x = Bit is unknown

- bit 15-14 **Unimplemented:** Read as '0'
- bit 13-8 **SCK2R[5:0]:** Assign SPI2 Clock Input (SCK2IN) to Corresponding RPn or RPIIn Pin bits
- bit 7-6 **Unimplemented:** Read as '0'
- bit 5-0 **SDI2R[5:0]:** Assign SPI2 Data Input (SDI2) to Corresponding RPn or RPIIn Pin bits

REGISTER 11-28: RPINR23: PERIPHERAL PIN SELECT INPUT REGISTER 23

U-0	U-0	R/W-1	R/W-1	R/W-1	R/W-1	R/W-1	R/W-1
—	—	TXCKR5	TXCKR4	TXCKR3	TXCKR2	TXCKR1	TXCKR0
bit 15							bit 8

U-0	U-0	R/W-1	R/W-1	R/W-1	R/W-1	R/W-1	R/W-1
—	—	SS2R5	SS2R4	SS2R3	SS2R2	SS2R1	SS2R0
bit 7							bit 0

Legend:

R = Readable bit W = Writable bit U = Unimplemented bit, read as '0'
 -n = Value at POR '1' = Bit is set '0' = Bit is cleared x = Bit is unknown

- bit 15-14 **Unimplemented:** Read as '0'
- bit 13-8 **TXCKR[5:0]:** Assign General Timer External Input (TxCK) to Corresponding RPn or RPIIn Pin bits
- bit 7-6 **Unimplemented:** Read as '0'
- bit 5-0 **SS2R[5:0]:** Assign SPI2 Slave Select Input (SS2IN) to Corresponding RPn or RPIIn Pin bits

PIC24FJ256GA705 FAMILY

REGISTER 11-29: RPINR25: PERIPHERAL PIN SELECT INPUT REGISTER 25

U-0	U-0	R/W-1	R/W-1	R/W-1	R/W-1	R/W-1	R/W-1
—	—	CLCINBR5	CLCINBR4	CLCINBR3	CLCINBR2	CLCINBR1	CLCINBR0
bit 15							bit 8

U-0	U-0	R/W-1	R/W-1	R/W-1	R/W-1	R/W-1	R/W-1
—	—	CLCINAR5	CLCINAR4	CLCINAR3	CLCINAR2	CLCINAR1	CLCINAR0
bit 7							bit 0

Legend:

R = Readable bit W = Writable bit U = Unimplemented bit, read as '0'
 -n = Value at POR '1' = Bit is set '0' = Bit is cleared x = Bit is unknown

- bit 15-14 **Unimplemented:** Read as '0'
- bit 13-8 **CLCINBR[5:0]:** Assign CLC Input B (CLCINB) to Corresponding RPn or RPIIn Pin bits
- bit 7-6 **Unimplemented:** Read as '0'
- bit 5-0 **CLCINAR[5:0]:** Assign CLC Input A (CLCINA) to Corresponding RPn or RPIIn Pin bits

REGISTER 11-30: RPINR28: PERIPHERAL PIN SELECT INPUT REGISTER 28

U-0	U-0	R/W-1	R/W-1	R/W-1	R/W-1	R/W-1	R/W-1
—	—	SCK3R5	SCK3R4	SCK3R3	SCK3R2	SCK3R1	SCK3R0
bit 15							bit 8

U-0	U-0	R/W-1	R/W-1	R/W-1	R/W-1	R/W-1	R/W-1
—	—	SDI3R5	SDI3R4	SDI3R3	SDI3R2	SDI3R1	SDI3R0
bit 7							bit 0

Legend:

R = Readable bit W = Writable bit U = Unimplemented bit, read as '0'
 -n = Value at POR '1' = Bit is set '0' = Bit is cleared x = Bit is unknown

- bit 15-14 **Unimplemented:** Read as '0'
- bit 13-8 **SCK3R[5:0]:** Assign SPI3 Clock Input (SCK3IN) to Corresponding RPn or RPIIn Pin bits
- bit 7-6 **Unimplemented:** Read as '0'
- bit 5-0 **SDI3R[5:0]:** Assign SPI3 Data Input (SDI3) to Corresponding RPn or RPIIn Pin bits

PIC24FJ256GA705 FAMILY

REGISTER 11-31: RPINR29: PERIPHERAL PIN SELECT INPUT REGISTER 29

U-0	U-0	U-0	U-0	U-0	U-0	U-0	U-0
—	—	—	—	—	—	—	—
bit 15							bit 8

U-0	U-0	R/W-1	R/W-1	R/W-1	R/W-1	R/W-1	R/W-1
—	—	SS3R5	SS3R4	SS3R3	SS3R2	SS3R1	SS3R0
bit 7							bit 0

Legend:

R = Readable bit W = Writable bit U = Unimplemented bit, read as '0'
 -n = Value at POR '1' = Bit is set '0' = Bit is cleared x = Bit is unknown

bit 15-6 **Unimplemented:** Read as '0'

bit 5-0 **SS3R[5:0]:** Assign SPI3 Slave Select Input (SS3IN) to Corresponding RPN or RPN Pin bits

PIC24FJ256GA705 FAMILY

REGISTER 11-32: RPOR0: PERIPHERAL PIN SELECT OUTPUT REGISTER 0

U-0	U-0	R/W-0	R/W-0	R/W-0	R/W-0	R/W-0	R/W-0
—	—	RP1R5	RP1R4	RP1R3	RP1R2	RP1R1	RP1R0
bit 15							bit 8

U-0	U-0	R/W-0	R/W-0	R/W-0	R/W-0	R/W-0	R/W-0
—	—	RP0R5	RP0R4	RP0R3	RP0R2	RP0R1	RP0R0
bit 7							bit 0

Legend:

R = Readable bit W = Writable bit U = Unimplemented bit, read as '0'
 -n = Value at POR '1' = Bit is set '0' = Bit is cleared x = Bit is unknown

- bit 15-14 **Unimplemented:** Read as '0'
- bit 13-8 **RP1R[5:0]:** RP1 Output Pin Mapping bits
Peripheral Output Number n is assigned to pin, RP1 (see [Table 11-7](#) for peripheral function numbers).
- bit 7-6 **Unimplemented:** Read as '0'
- bit 5-0 **RP0R[5:0]:** RP0 Output Pin Mapping bits
Peripheral Output Number n is assigned to pin, RP0 (see [Table 11-7](#) for peripheral function numbers).

REGISTER 11-33: RPOR1: PERIPHERAL PIN SELECT OUTPUT REGISTER 1

U-0	U-0	R/W-0	R/W-0	R/W-0	R/W-0	R/W-0	R/W-0
—	—	RP3R5	RP3R4	RP3R3	RP3R2	RP3R1	RP3R0
bit 15							bit 8

U-0	U-0	R/W-0	R/W-0	R/W-0	R/W-0	R/W-0	R/W-0
—	—	RP2R5	RP2R4	RP2R3	RP2R2	RP2R1	RP2R0
bit 7							bit 0

Legend:

R = Readable bit W = Writable bit U = Unimplemented bit, read as '0'
 -n = Value at POR '1' = Bit is set '0' = Bit is cleared x = Bit is unknown

- bit 15-14 **Unimplemented:** Read as '0'
- bit 13-8 **RP3R[5:0]:** RP3 Output Pin Mapping bits
Peripheral Output Number n is assigned to pin, RP3 (see [Table 11-7](#) for peripheral function numbers).
- bit 7-6 **Unimplemented:** Read as '0'
- bit 5-0 **RP2R[5:0]:** RP2 Output Pin Mapping bits
Peripheral Output Number n is assigned to pin, RP2 (see [Table 11-7](#) for peripheral function numbers).

PIC24FJ256GA705 FAMILY

REGISTER 11-34: RPOR2: PERIPHERAL PIN SELECT OUTPUT REGISTER 2

U-0	U-0	R/W-0	R/W-0	R/W-0	R/W-0	R/W-0	R/W-0
—	—	RP5R5	RP5R4	RP5R3	RP5R2	RP5R1	RP5R0
bit 15						bit 8	

U-0	U-0	R/W-0	R/W-0	R/W-0	R/W-0	R/W-0	R/W-0
—	—	RP4R5	RP4R4	RP4R3	RP4R2	RP4R1	RP4R0
bit 7						bit 0	

Legend:

R = Readable bit W = Writable bit U = Unimplemented bit, read as '0'
 -n = Value at POR '1' = Bit is set '0' = Bit is cleared x = Bit is unknown

- bit 15-14 **Unimplemented:** Read as '0'
- bit 13-8 **RP5R[5:0]:** RP5 Output Pin Mapping bits
 Peripheral Output Number n is assigned to pin, RP5 (see [Table 11-7](#) for peripheral function numbers).
- bit 7-6 **Unimplemented:** Read as '0'
- bit 5-0 **RP4R[5:0]:** RP4 Output Pin Mapping bits
 Peripheral Output Number n is assigned to pin, RP4 (see [Table 11-7](#) for peripheral function numbers).

REGISTER 11-35: RPOR3: PERIPHERAL PIN SELECT OUTPUT REGISTER 3

U-0	U-0	R/W-0	R/W-0	R/W-0	R/W-0	R/W-0	R/W-0
—	—	RP7R5	RP7R4	RP7R3	RP7R2	RP7R1	RP7R0
bit 15						bit 8	

U-0	U-0	R/W-0	R/W-0	R/W-0	R/W-0	R/W-0	R/W-0
—	—	RP6R5	RP6R4	RP6R3	RP6R2	RP6R1	RP6R0
bit 7						bit 0	

Legend:

R = Readable bit W = Writable bit U = Unimplemented bit, read as '0'
 -n = Value at POR '1' = Bit is set '0' = Bit is cleared x = Bit is unknown

- bit 15-14 **Unimplemented:** Read as '0'
- bit 13-8 **RP7R[5:0]:** RP7 Output Pin Mapping bits
 Peripheral Output Number n is assigned to pin, RP7 (see [Table 11-7](#) for peripheral function numbers).
- bit 7-6 **Unimplemented:** Read as '0'
- bit 5-0 **RP6R[5:0]:** RP6 Output Pin Mapping bits
 Peripheral Output Number n is assigned to pin, RP6 (see [Table 11-7](#) for peripheral function numbers).

PIC24FJ256GA705 FAMILY

REGISTER 11-36: RPOR4: PERIPHERAL PIN SELECT OUTPUT REGISTER 4

U-0	U-0	R/W-0	R/W-0	R/W-0	R/W-0	R/W-0	R/W-0
—	—	RP9R5	RP9R4	RP9R3	RP9R2	RP9R1	RP9R0
bit 15							bit 8

U-0	U-0	R/W-0	R/W-0	R/W-0	R/W-0	R/W-0	R/W-0
—	—	RP8R5	RP8R4	RP8R3	RP8R2	RP8R1	RP8R0
bit 7							bit 0

Legend:

R = Readable bit W = Writable bit U = Unimplemented bit, read as '0'
 -n = Value at POR '1' = Bit is set '0' = Bit is cleared x = Bit is unknown

- bit 15-14 **Unimplemented:** Read as '0'
- bit 13-8 **RP9R[5:0]:** RP9 Output Pin Mapping bits
 Peripheral Output Number n is assigned to pin, RP9 (see [Table 11-7](#) for peripheral function numbers).
- bit 7-6 **Unimplemented:** Read as '0'
- bit 5-0 **RP8R[5:0]:** RP8 Output Pin Mapping bits
 Peripheral Output Number n is assigned to pin, RP8 (see [Table 11-7](#) for peripheral function numbers).

REGISTER 11-37: RPOR5: PERIPHERAL PIN SELECT OUTPUT REGISTER 5

U-0	U-0	R/W-0	R/W-0	R/W-0	R/W-0	R/W-0	R/W-0
—	—	RP11R5	RP11R4	RP11R3	RP11R2	RP11R1	RP11R0
bit 15							bit 8

U-0	U-0	R/W-0	R/W-0	R/W-0	R/W-0	R/W-0	R/W-0
—	—	RP10R5	RP10R4	RP10R3	RP10R2	RP10R1	RP10R0
bit 7							bit 0

Legend:

R = Readable bit W = Writable bit U = Unimplemented bit, read as '0'
 -n = Value at POR '1' = Bit is set '0' = Bit is cleared x = Bit is unknown

- bit 15-14 **Unimplemented:** Read as '0'
- bit 13-8 **RP11R[5:0]:** RP11 Output Pin Mapping bits
 Peripheral Output Number n is assigned to pin, RP11 (see [Table 11-7](#) for peripheral function numbers).
- bit 7-6 **Unimplemented:** Read as '0'
- bit 5-0 **RP10R[5:0]:** RP10 Output Pin Mapping bits
 Peripheral Output Number n is assigned to pin, RP10 (see [Table 11-7](#) for peripheral function numbers).

PIC24FJ256GA705 FAMILY

REGISTER 11-38: RPOR6: PERIPHERAL PIN SELECT OUTPUT REGISTER 6

U-0	U-0	R/W-0	R/W-0	R/W-0	R/W-0	R/W-0	R/W-0
—	—	RP13R5	RP13R4	RP13R3	RP13R2	RP13R1	RP13R0
bit 15							bit 8

U-0	U-0	R/W-0	R/W-0	R/W-0	R/W-0	R/W-0	R/W-0
—	—	RP12R5	RP12R4	RP12R3	RP12R2	RP12R1	RP12R0
bit 7							bit 0

Legend:

R = Readable bit W = Writable bit U = Unimplemented bit, read as '0'
 -n = Value at POR '1' = Bit is set '0' = Bit is cleared x = Bit is unknown

- bit 15-14 **Unimplemented:** Read as '0'
- bit 13-8 **RP13R[5:0]:** RP13 Output Pin Mapping bits
 Peripheral Output Number n is assigned to pin, RP13 (see [Table 11-7](#) for peripheral function numbers).
- bit 7-6 **Unimplemented:** Read as '0'
- bit 5-0 **RP12R[5:0]:** RP12 Output Pin Mapping bits
 Peripheral Output Number n is assigned to pin, RP12 (see [Table 11-7](#) for peripheral function numbers).

REGISTER 11-39: RPOR7: PERIPHERAL PIN SELECT OUTPUT REGISTER 7

U-0	U-0	R/W-0	R/W-0	R/W-0	R/W-0	R/W-0	R/W-0
—	—	RP15R5	RP15R4	RP15R3	RP15R2	RP15R1	RP15R0
bit 15							bit 8

U-0	U-0	R/W-0	R/W-0	R/W-0	R/W-0	R/W-0	R/W-0
—	—	RP14R5	RP14R4	RP14R3	RP14R2	RP14R1	RP14R0
bit 7							bit 0

Legend:

R = Readable bit W = Writable bit U = Unimplemented bit, read as '0'
 -n = Value at POR '1' = Bit is set '0' = Bit is cleared x = Bit is unknown

- bit 15-14 **Unimplemented:** Read as '0'
- bit 13-8 **RP15R[5:0]:** RP15 Output Pin Mapping bits
 Peripheral Output Number n is assigned to pin, RP15 (see [Table 11-7](#) for peripheral function numbers).
- bit 7-6 **Unimplemented:** Read as '0'
- bit 5-0 **RP14R[5:0]:** RP14 Output Pin Mapping bits
 Peripheral Output Number n is assigned to pin, RP14 (see [Table 11-7](#) for peripheral function numbers).

PIC24FJ256GA705 FAMILY

REGISTER 11-40: RPOR8: PERIPHERAL PIN SELECT OUTPUT REGISTER 8

U-0	U-0	R/W-0	R/W-0	R/W-0	R/W-0	R/W-0	R/W-0
—	—	RP17R5	RP17R4	RP17R3	RP17R2	RP17R1	RP17R0
bit 15							bit 8

U-0	U-0	R/W-0	R/W-0	R/W-0	R/W-0	R/W-0	R/W-0
—	—	RP16R5	RP16R4	RP16R3	RP16R2	RP16R1	RP16R0
bit 7							bit 0

Legend:

R = Readable bit W = Writable bit U = Unimplemented bit, read as '0'
 -n = Value at POR '1' = Bit is set '0' = Bit is cleared x = Bit is unknown

- bit 15-14 **Unimplemented:** Read as '0'
- bit 13-8 **RP17R[5:0]:** RP17 Output Pin Mapping bits
 Peripheral Output Number n is assigned to pin, RP17 (see [Table 11-7](#) for peripheral function numbers).
- bit 7-6 **Unimplemented:** Read as '0'
- bit 5-0 **RP16R[5:0]:** RP16 Output Pin Mapping bits
 Peripheral Output Number n is assigned to pin, RP16 (see [Table 11-7](#) for peripheral function numbers).

REGISTER 11-41: RPOR9: PERIPHERAL PIN SELECT OUTPUT REGISTER 9

U-0	U-0	R/W-0	R/W-0	R/W-0	R/W-0	R/W-0	R/W-0
—	—	RP19R5	RP19R4	RP19R3	RP19R2	RP19R1	RP19R0
bit 15							bit 8

U-0	U-0	R/W-0	R/W-0	R/W-0	R/W-0	R/W-0	R/W-0
—	—	RP18R5	RP18R4	RP18R3	RP18R2	RP18R1	RP18R0
bit 7							bit 0

Legend:

R = Readable bit W = Writable bit U = Unimplemented bit, read as '0'
 -n = Value at POR '1' = Bit is set '0' = Bit is cleared x = Bit is unknown

- bit 15-14 **Unimplemented:** Read as '0'
- bit 13-8 **RP19R[5:0]:** RP19 Output Pin Mapping bits
 Peripheral Output Number n is assigned to pin, RP19 (see [Table 11-7](#) for peripheral function numbers).
- bit 7-6 **Unimplemented:** Read as '0'
- bit 5-0 **RP18R[5:0]:** RP18 Output Pin Mapping bits
 Peripheral Output Number n is assigned to pin, RP18 (see [Table 11-7](#) for peripheral function numbers).

PIC24FJ256GA705 FAMILY

REGISTER 11-42: RPOR10: PERIPHERAL PIN SELECT OUTPUT REGISTER 10

U-0	U-0	R/W-0	R/W-0	R/W-0	R/W-0	R/W-0	R/W-0
—	—	RP21R5	RP21R4	RP21R3	RP21R2	RP21R1	RP21R0
bit 15							bit 8

U-0	U-0	R/W-0	R/W-0	R/W-0	R/W-0	R/W-0	R/W-0
—	—	RP20R5	RP20R4	RP20R3	RP20R2	RP20R1	RP20R0
bit 7							bit 0

Legend:

R = Readable bit W = Writable bit U = Unimplemented bit, read as '0'
 -n = Value at POR '1' = Bit is set '0' = Bit is cleared x = Bit is unknown

- bit 15-14 **Unimplemented:** Read as '0'
- bit 13-8 **RP21R[5:0]:** RP21 Output Pin Mapping bits
 Peripheral Output Number n is assigned to pin, RP21 (see [Table 11-7](#) for peripheral function numbers).
- bit 7-6 **Unimplemented:** Read as '0'
- bit 5-0 **RP20R[5:0]:** RP20 Output Pin Mapping bits
 Peripheral Output Number n is assigned to pin, RP20 (see [Table 11-7](#) for peripheral function numbers).

REGISTER 11-43: RPOR11: PERIPHERAL PIN SELECT OUTPUT REGISTER 11

U-0	U-0	R/W-0	R/W-0	R/W-0	R/W-0	R/W-0	R/W-0
—	—	RP23R5	RP23R4	RP23R3	RP23R2	RP23R1	RP23R0
bit 15							bit 8

U-0	U-0	R/W-0	R/W-0	R/W-0	R/W-0	R/W-0	R/W-0
—	—	RP22R5	RP22R4	RP22R3	RP22R2	RP22R1	RP22R0
bit 7							bit 0

Legend:

R = Readable bit W = Writable bit U = Unimplemented bit, read as '0'
 -n = Value at POR '1' = Bit is set '0' = Bit is cleared x = Bit is unknown

- bit 15-14 **Unimplemented:** Read as '0'
- bit 13-8 **RP23R[5:0]:** RP23 Output Pin Mapping bits
 Peripheral Output Number n is assigned to pin, RP23 (see [Table 11-7](#) for peripheral function numbers).
- bit 7-6 **Unimplemented:** Read as '0'
- bit 5-0 **RP22R[5:0]:** RP22 Output Pin Mapping bits
 Peripheral Output Number n is assigned to pin, RP22 (see [Table 11-7](#) for peripheral function numbers).

PIC24FJ256GA705 FAMILY

REGISTER 11-44: RPOR12: PERIPHERAL PIN SELECT OUTPUT REGISTER 12

U-0	U-0	R/W-0	R/W-0	R/W-0	R/W-0	R/W-0	R/W-0
—	—	RP25R5	RP25R4	RP25R3	RP25R2	RP25R1	RP25R0
bit 15							bit 8

U-0	U-0	R/W-0	R/W-0	R/W-0	R/W-0	R/W-0	R/W-0
—	—	RP24R5	RP24R4	RP24R3	RP24R2	RP24R1	RP24R0
bit 7							bit 0

Legend:

R = Readable bit W = Writable bit U = Unimplemented bit, read as '0'
 -n = Value at POR '1' = Bit is set '0' = Bit is cleared x = Bit is unknown

- bit 15-14 **Unimplemented:** Read as '0'
- bit 13-8 **RP25R[5:0]:** RP25 Output Pin Mapping bits
 Peripheral Output Number n is assigned to pin, RP25 (see [Table 11-7](#) for peripheral function numbers).
- bit 7-6 **Unimplemented:** Read as '0'
- bit 5-0 **RP24R[5:0]:** RP24 Output Pin Mapping bits
 Peripheral Output Number n is assigned to pin, RP24 (see [Table 11-7](#) for peripheral function numbers).

REGISTER 11-45: RPOR13: PERIPHERAL PIN SELECT OUTPUT REGISTER 13

U-0	U-0	R/W-0	R/W-0	R/W-0	R/W-0	R/W-0	R/W-0
—	—	RP27R5	RP27R4	RP27R3	RP27R2	RP27R1	RP27R0
bit 15							bit 8

U-0	U-0	R/W-0	R/W-0	R/W-0	R/W-0	R/W-0	R/W-0
—	—	RP26R5	RP26R4	RP26R3	RP26R2	RP26R1	RP26R0
bit 7							bit 0

Legend:

R = Readable bit W = Writable bit U = Unimplemented bit, read as '0'
 -n = Value at POR '1' = Bit is set '0' = Bit is cleared x = Bit is unknown

- bit 15-14 **Unimplemented:** Read as '0'
- bit 13-8 **RP27R[5:0]:** RP27 Output Pin Mapping bits
 Peripheral Output Number n is assigned to pin, RP27 (see [Table 11-7](#) for peripheral function numbers).
- bit 7-6 **Unimplemented:** Read as '0'
- bit 5-0 **RP26R[5:0]:** RP26 Output Pin Mapping bits
 Peripheral Output Number n is assigned to pin, RP26 (see [Table 11-7](#) for peripheral function numbers).

PIC24FJ256GA705 FAMILY

REGISTER 11-46: RPOR14: PERIPHERAL PIN SELECT OUTPUT REGISTER 14

U-0	U-0	U-0	U-0	U-0	U-0	U-0	U-0
—	—	—	—	—	—	—	—
bit 15						bit 8	

U-0	U-0	R/W-0	R/W-0	R/W-0	R/W-0	R/W-0	R/W-0
—	—	RP28R5	RP28R4	RP28R3	RP28R2	RP28R1	RP28R0
bit 7						bit 0	

Legend:

R = Readable bit

W = Writable bit

U = Unimplemented bit, read as '0'

-n = Value at POR

'1' = Bit is set

'0' = Bit is cleared

x = Bit is unknown

bit 15-6

Unimplemented: Read as '0'

bit 5-0

RP28R[5:0]: RP28 Output Pin Mapping bits

Peripheral Output Number n is assigned to pin, RP28 (see [Table 11-7](#) for peripheral function numbers).

12.0 TIMER1

Note: This data sheet summarizes the features of this group of PIC24F devices. It is not intended to be a comprehensive reference source. For more information, refer to “Timers” (www.microchip.com/DS39704) in the “dsPIC33/PIC24 Family Reference Manual”. The information in this data sheet supersedes the information in the FRM.

The Timer1 module is a 16-bit timer, which can serve as the time counter for the Real-Time Clock (RTC) or operate as a free-running, interval timer/counter. Timer1 can operate in three modes:

- 16-Bit Timer
- 16-Bit Synchronous Counter
- 16-Bit Asynchronous Counter

Timer1 also supports these features:

- Timer Gate Operation
- Selectable Prescaler Settings
- Timer Operation during CPU Idle and Sleep modes
- Interrupt on 16-Bit Period Register Match or Falling Edge of External Gate Signal

Figure 12-1 presents a block diagram of the 16-bit timer module.

To configure Timer1 for operation:

1. Set the TON bit (= 1).
2. Select the timer prescaler ratio using the TCKPS[1:0] bits.
3. Set the Clock and Gating modes using the TCS, TECS[1:0] and TGATE bits.
4. Set or clear the TSYNC bit to configure synchronous or asynchronous operation.
5. Load the timer period value into the PR1 register.
6. If interrupts are required, set the interrupt enable bit, T1IE. Use the priority bits, T1IP[2:0], to set the interrupt priority.

FIGURE 12-1: 16-BIT TIMER1 MODULE BLOCK DIAGRAM

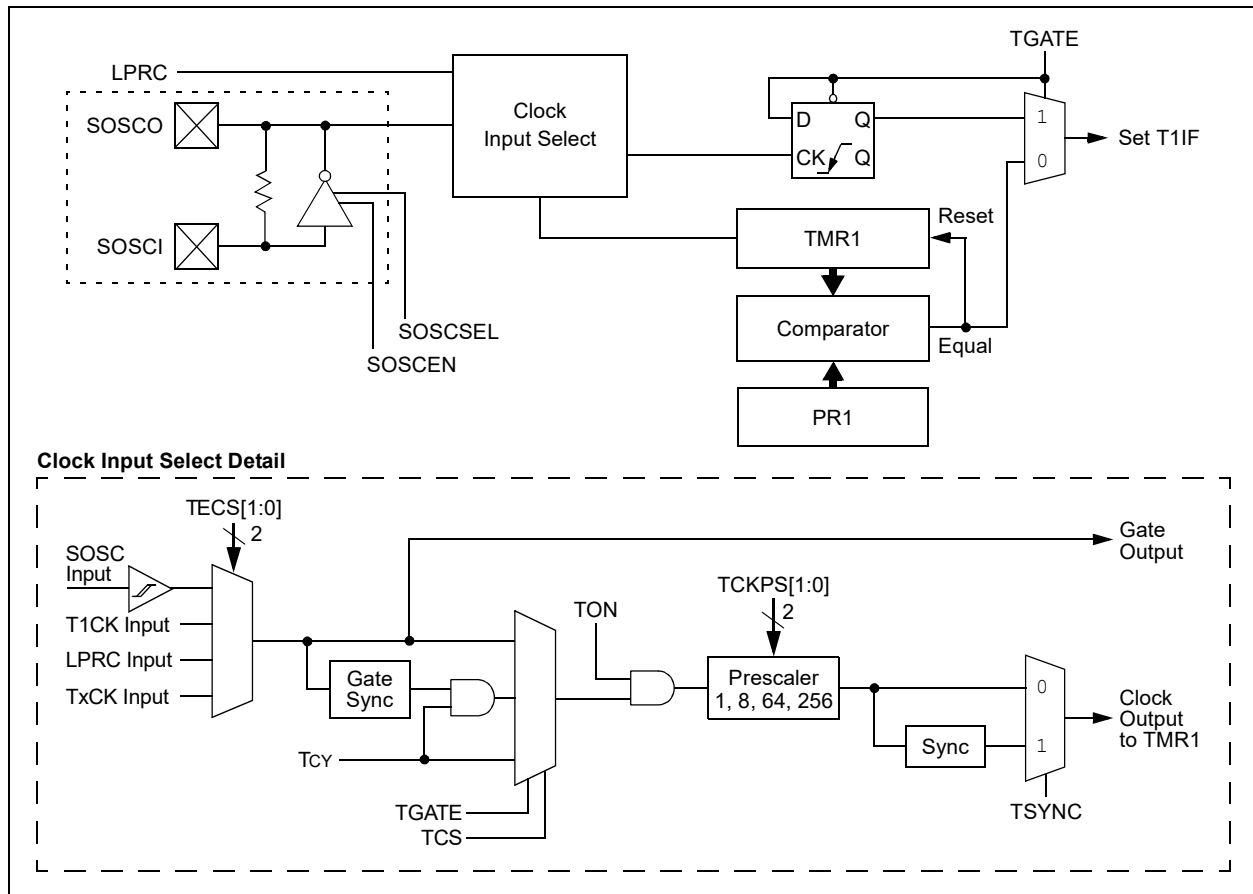

PIC24FJ256GA705 FAMILY

REGISTER 12-1: T1CON: TIMER1 CONTROL REGISTER⁽¹⁾

R/W-0	U-0	R/W-0	U-0	U-0	U-0	R/W-0	R/W-0
TON	—	TSIDL	—	—	—	TECS1	TECS0
bit 15						bit 8	

U-0	R/W-0	R/W-0	R/W-0	U-0	R/W-0	R/W-0	U-0
—	TGATE	TCKPS1	TCKPS0	—	TSYNC	TCS	—
bit 7						bit 0	

Legend:

R = Readable bit W = Writable bit U = Unimplemented bit, read as '0'
 -n = Value at POR '1' = Bit is set '0' = Bit is cleared x = Bit is unknown

- bit 15 **TON:** Timer1 On bit
 1 = Starts 16-bit Timer1
 0 = Stops 16-bit Timer1
- bit 14 **Unimplemented:** Read as '0'
- bit 13 **TSIDL:** Timer1 Stop in Idle Mode bit
 1 = Discontinues module operation when device enters Idle mode
 0 = Continues module operation in Idle mode
- bit 12-10 **Unimplemented:** Read as '0'
- bit 9-8 **TECS[1:0]:** Timer1 Extended Clock Source Select bits (selected when TCS = 1)
 11 = Generic timer (TxCK) external input
 10 = LPRC Oscillator
 01 = T1CK external clock input
 00 = SOSC
- bit 7 **Unimplemented:** Read as '0'
- bit 6 **TGATE:** Timer1 Gated Time Accumulation Enable bit
 When TCS = 1:
 This bit is ignored.
 When TCS = 0:
 1 = Gated time accumulation is enabled
 0 = Gated time accumulation is disabled
- bit 5-4 **TCKPS[1:0]:** Timer1 Input Clock Prescale Select bits
 11 = 1:256
 10 = 1:64
 01 = 1:8
 00 = 1:1
- bit 3 **Unimplemented:** Read as '0'
- bit 2 **TSYNC:** Timer1 External Clock Input Synchronization Select bit
 When TCS = 1:
 1 = Synchronizes the external clock input
 0 = Does not synchronize the external clock input
 When TCS = 0:
 This bit is ignored.
- bit 1 **TCS:** Timer1 Clock Source Select bit
 1 = Extended clock is selected by the timer
 0 = Internal clock (FOSC/2)
- bit 0 **Unimplemented:** Read as '0'

Note 1: Changing the value of T1CON while the timer is running (TON = 1) causes the timer prescale counter to reset and is not recommended.

13.0 TIMER2/3

Note: This data sheet summarizes the features of this group of PIC24F devices. It is not intended to be a comprehensive reference source. For more information, refer to “Timers” (www.microchip.com/DS39704) in the “dsPIC33/PIC24 Family Reference Manual”. The information in this data sheet supersedes the information in the FRM.

The Timer2/3 module is a 32-bit timer, which can also be configured as independent, 16-bit timers with selectable operating modes.

As a 32-bit timer, Timer2/3 can operate in three modes:

- Two Independent 16-Bit Timers with All 16-Bit Operating modes (except Asynchronous Counter mode)
- Single 32-Bit Timer
- Single 32-Bit Synchronous Counter

They also support these features:

- Timer Gate Operation
- Selectable Prescaler Settings
- Timer Operation during Idle and Sleep modes
- Interrupt on a 32-Bit Period Register Match
- A/D Event Trigger (on Timer2/3 in 32-bit mode and Timer3 in 16-bit mode)

Individually, all of the 16-bit timers can function as synchronous timers or counters. They also offer the features listed above, except for the A/D event trigger. This trigger is implemented only on Timer2/3 in 32-bit mode and Timer3 in 16-bit mode. The operating modes and enabled features are determined by setting the appropriate bit(s) in the T2CON and T3CON registers. T2CON is shown in generic form in [Register 13-1](#); T3CON is shown in [Register 13-2](#).

For 32-bit timer/counter operation, Timer2 is the least significant word; Timer3 is the most significant word of the 32-bit timer.

Note: For 32-bit operation, T3CON control bits are ignored. Only T2CON control bits are used for setup and control. Timer2 clock and gate inputs are utilized for the 32-bit timer modules, but an interrupt is generated with the Timer3 interrupt flags.

To configure Timer2/3 for 32-bit operation:

1. Set the T32 bit (T2CON[3] = 1).
2. Select the prescaler ratio for Timer2 using the TCKPS[1:0] bits.
3. Set the Clock and Gating modes using the TCS and TGATE bits. If TCS is set to an external clock, RPINRx (TyCK) must be configured to an available RPn/RPIn pin. For more information, see [Section 11.5 “Peripheral Pin Select \(PPS\)”](#).
4. Load the timer period value. PR3 will contain the most significant word (msw) of the value, while PR2 contains the least significant word (lsw).
5. If interrupts are required, set the interrupt enable bit, T3IE. Use the priority bits, T3IP[2:0], to set the interrupt priority. Note that while Timer2 controls the timer, the interrupt appears as a Timer3 interrupt.
6. Set the TON bit (= 1).

The timer value, at any point, is stored in the register pair, TMR[3:2]. TMR3 always contains the most significant word of the count, while TMR2 contains the least significant word.

To configure any of the timers for individual 16-bit operation:

1. Clear the T32 bit (T2CON[3]).
2. Select the timer prescaler ratio using the TCKPS[1:0] bits.
3. Set the Clock and Gating modes using the TCS and TGATE bits. See [Section 11.5 “Peripheral Pin Select \(PPS\)”](#) for more information.
4. Load the timer period value into the PRx register.
5. If interrupts are required, set the interrupt enable bit, TxIE. Use the priority bits, TxIP[2:0], to set the interrupt priority.
6. Set the TON (TxCON[15] = 1) bit.

PIC24FJ256GA705 FAMILY

FIGURE 13-1: TIMER2/3 (32-BIT) BLOCK DIAGRAM

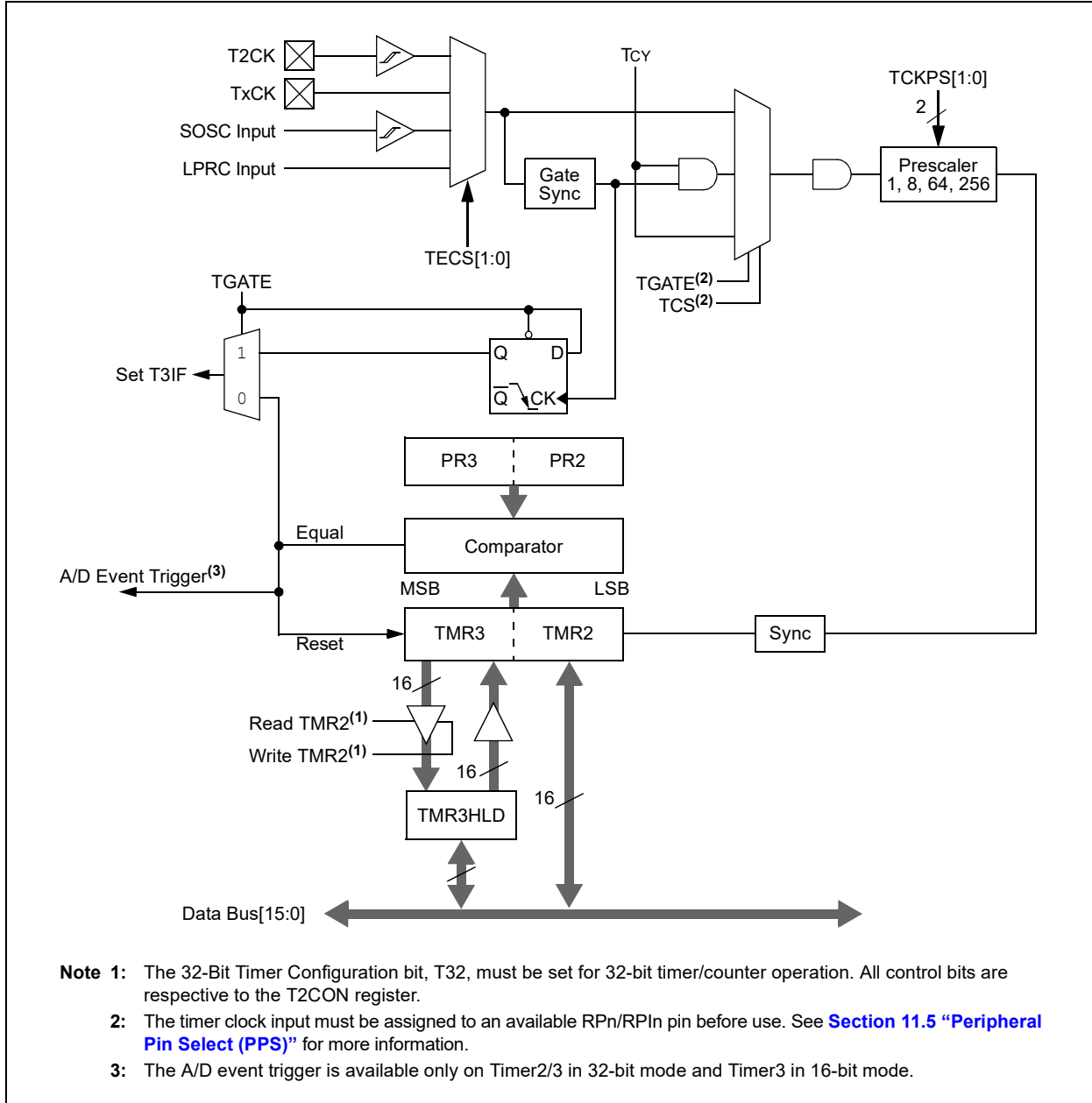

FIGURE 13-2: TIMER2 (16-BIT SYNCHRONOUS) BLOCK DIAGRAM

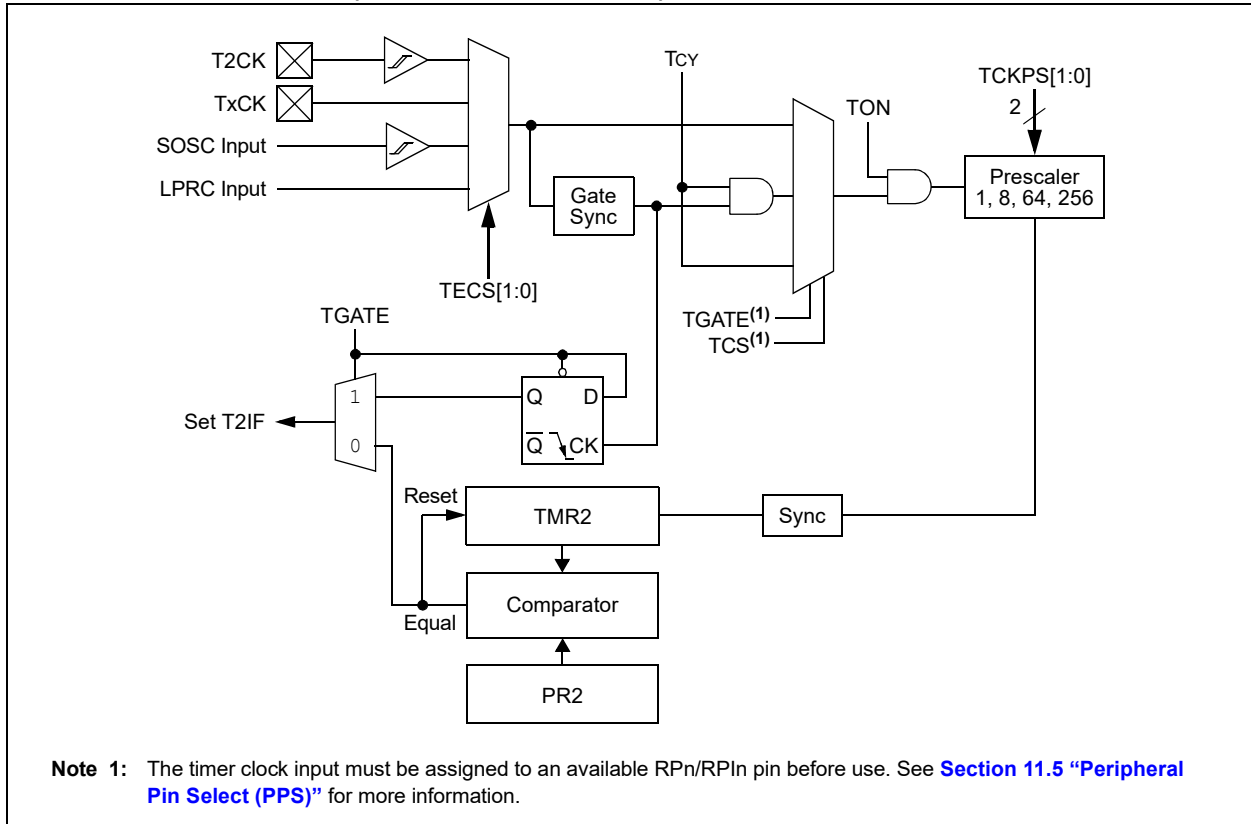
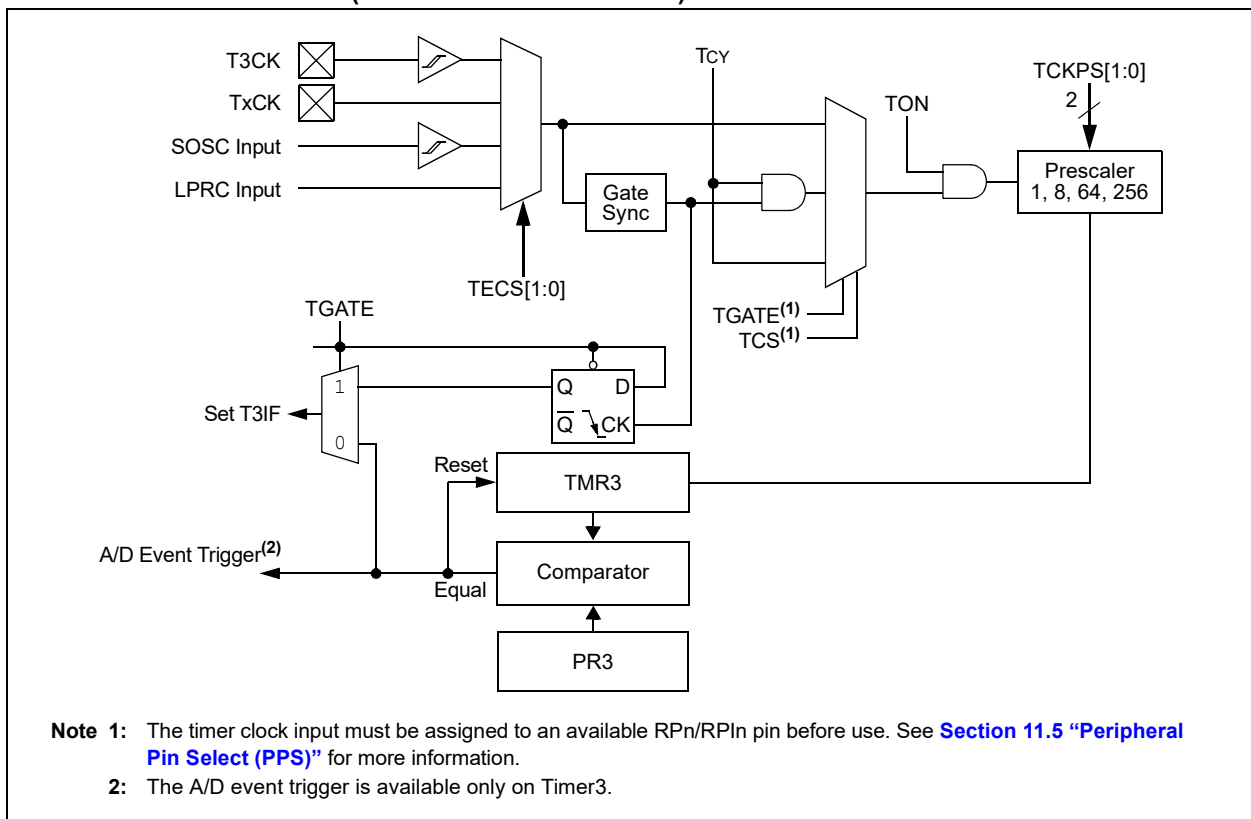

FIGURE 13-3: TIMER3 (16-BIT ASYNCHRONOUS) BLOCK DIAGRAM



PIC24FJ256GA705 FAMILY

REGISTER 13-1: TxCON: TIMER2 CONTROL REGISTER⁽¹⁾

R/W-0	U-0	R/W-0	U-0	U-0	U-0	R/W-0	R/W-0
TON	—	TSIDL	—	—	—	TECS1 ⁽²⁾	TECS0 ⁽²⁾
bit 15						bit 8	

U-0	R/W-0	R/W-0	R/W-0	R/W-0	U-0	R/W-0	U-0
—	TGATE	TCKPS1	TCKPS0	T32 ⁽³⁾	—	TCS ⁽²⁾	—
bit 7						bit 0	

Legend:

R = Readable bit

W = Writable bit

U = Unimplemented bit, read as '0'

-n = Value at POR

'1' = Bit is set

'0' = Bit is cleared

x = Bit is unknown

bit 15 **TON:** Timerx On bit

When TxCON[3] = 1:

1 = Starts 32-bit Timerx/y

0 = Stops 32-bit Timerx/y

When TxCON[3] = 0:

1 = Starts 16-bit Timerx

0 = Stops 16-bit Timerx

bit 14 **Unimplemented:** Read as '0'

bit 13 **TSIDL:** Timerx Stop in Idle Mode bit

1 = Discontinues module operation when device enters Idle mode

0 = Continues module operation in Idle mode

bit 12-10 **Unimplemented:** Read as '0'

bit 9-8 **TECS[1:0]:** Timerx Extended Clock Source Select bits (selected when TCS = 1)⁽²⁾

When TCS = 1:

11 = Generic timer (TxCK) external input

10 = LPRC Oscillator

01 = TyCK external clock input

00 = SOSC

When TCS = 0:

These bits are ignored; the timer is clocked from the internal system clock (Fosc/2).

bit 7 **Unimplemented:** Read as '0'

bit 6 **TGATE:** Timerx Gated Time Accumulation Enable bit

When TCS = 1:

This bit is ignored.

When TCS = 0:

1 = Gated time accumulation is enabled

0 = Gated time accumulation is disabled

bit 5-4 **TCKPS[1:0]:** Timerx Input Clock Prescale Select bits

11 = 1:256

10 = 1:64

01 = 1:8

00 = 1:1

Note 1: Changing the value of TxCON while the timer is running (TON = 1) causes the timer prescale counter to reset and is not recommended.

2: If TCS = 1 and TECS[1:0] = x1, the selected external timer input (TxCK or TyCK) must be configured to an available RPN/RPI pin. For more information, see [Section 11.5 “Peripheral Pin Select \(PPS\)”](#).

3: In 32-bit mode, the T3CON control bits do not affect 32-bit timer operation.

REGISTER 13-1: TxCON: TIMER2 CONTROL REGISTER⁽¹⁾ (CONTINUED)

bit 3	T32: 32-Bit Timer Mode Select bit ⁽³⁾ 1 = Timerx and Timery form a single 32-bit timer 0 = Timerx and Timery act as two 16-bit timers In 32-bit mode, T3CON control bits do not affect 32-bit timer operation.
bit 2	Unimplemented: Read as '0'
bit 1	TCS: Timerx Clock Source Select bit ⁽²⁾ 1 = Timer source is selected by TECS[1:0] 0 = Internal clock (FOSC/2)
bit 0	Unimplemented: Read as '0'

- Note 1:** Changing the value of TxCON while the timer is running (TON = 1) causes the timer prescale counter to reset and is not recommended.
- 2:** If TCS = 1 and TECS[1:0] = x1, the selected external timer input (TxCK or TyCK) must be configured to an available RPN/RPIn pin. For more information, see [Section 11.5 “Peripheral Pin Select \(PPS\)”](#).
- 3:** In 32-bit mode, the T3CON control bits do not affect 32-bit timer operation.

PIC24FJ256GA705 FAMILY

REGISTER 13-2: TyCON: TIMER3 CONTROL REGISTER⁽¹⁾

R/W-0	U-0	R/W-0	U-0	U-0	U-0	R/W-0	R/W-0
TON ⁽²⁾	—	TSIDL ⁽²⁾	—	—	—	TECS1 ^(2,3)	TECS0 ^(2,3)
bit 15						bit 8	

U-0	R/W-0	R/W-0	R/W-0	U-0	U-0	R/W-0	U-0
—	TGATE ⁽²⁾	TCKPS1 ⁽²⁾	TCKPS0 ⁽²⁾	—	—	TCS ^(2,3)	—
bit 7						bit 0	

Legend:

R = Readable bit

W = Writable bit

U = Unimplemented bit, read as '0'

-n = Value at POR

'1' = Bit is set

'0' = Bit is cleared

x = Bit is unknown

bit 15 **TON:** Timery On bit⁽²⁾

1 = Starts 16-bit Timery

0 = Stops 16-bit Timery

bit 14 **Unimplemented:** Read as '0'

bit 13 **TSIDL:** Timery Stop in Idle Mode bit⁽²⁾

1 = Discontinues module operation when device enters Idle mode

0 = Continues module operation in Idle mode

bit 12-10 **Unimplemented:** Read as '0'

bit 9-8 **TECS[1:0]:** Timery Extended Clock Source Select bits (selected when TCS = 1)^(2,3)

11 = Generic timer (TxCK) external input

10 = LPRC Oscillator

01 = TyCK external clock input

00 = SOSC

bit 7 **Unimplemented:** Read as '0'

bit 6 **TGATE:** Timery Gated Time Accumulation Enable bit⁽²⁾

When TCS = 1:

This bit is ignored.

When TCS = 0:

1 = Gated time accumulation is enabled

0 = Gated time accumulation is disabled

bit 5-4 **TCKPS[1:0]:** Timery Input Clock Prescale Select bits⁽²⁾

11 = 1:256

10 = 1:64

01 = 1:8

00 = 1:1

bit 3-2 **Unimplemented:** Read as '0'

bit 1 **TCS:** Timery Clock Source Select bit^(2,3)

1 = External clock from pin, TyCK (on the rising edge)

0 = Internal clock (FOSC/2)

bit 0 **Unimplemented:** Read as '0'

Note 1: Changing the value of TyCON while the timer is running (TON = 1) causes the timer prescale counter to reset and is not recommended.

2: When 32-bit operation is enabled (T2CON[3] = 1), this bit has no effect on Timery operation; all timer functions are set through T2CON.

3: If TCS = 1 and TECS[1:0] = x1, the selected external timer input (TyCK) must be configured to an available RPN/RPIn pin. For more information, see [Section 11.5 "Peripheral Pin Select \(PPS\)"](#).

14.0 INPUT CAPTURE WITH DEDICATED TIMERS

Note: This data sheet summarizes the features of this group of PIC24F devices. It is not intended to be a comprehensive reference source. For more information, refer to "Input Capture with Dedicated Timer" (www.microchip.com/DS70000352) in the "dsPIC33/PIC24 Family Reference Manual". The information in this data sheet supersedes the information in the FRM.

Devices in the PIC24FJ256GA705 family contain three independent input capture modules. Each of the modules offers a wide range of configuration and operating options for capturing external pulse events and generating interrupts.

Key features of the input capture module include:

- Hardware-Configurable for 32-Bit Operation in All modes by Cascading Two Adjacent modules
- Synchronous and Trigger modes of Output Compare Operation with up to 31 User-Selectable Sync/Trigger Sources Available
- A 4-Level FIFO Buffer for Capturing and Holding Timer Values for Several Events
- Configurable Interrupt Generation
- Up to Six Clock Sources Available for Each module, Driving a Separate Internal 16-Bit Counter

The module is controlled through two registers: ICxCON1 (Register 14-1) and ICxCON2 (Register 14-2). A general block diagram of the module is shown in Figure 14-1.

14.1 General Operating Modes

14.1.1 SYNCHRONOUS AND TRIGGER MODES

When the input capture module operates in a Free-Running mode, the internal 16-bit counter, ICxTMR, counts up continuously, wrapping around from FFFFh to 0000h on each overflow. Its period is synchronized to the selected external clock source. When a capture event occurs, the current 16-bit value of the internal counter is written to the FIFO buffer.

In Synchronous mode, the module begins capturing events on the ICx pin as soon as its selected clock source is enabled. Whenever an event occurs on the selected Sync source, the internal counter is reset. In Trigger mode, the module waits for a Sync event from another internal module to occur before allowing the internal counter to run.

Standard, free-running operation is selected by setting the SYNCSEL[4:0] bits (ICxCON2[4:0]) to '00000' and clearing the ICTRIG bit (ICxCON2[7]). Synchronous and Trigger modes are selected any time the SYNCSELx bits are set to any value except '00000'. The ICTRIG bit selects either Synchronous or Trigger mode; setting the bit selects Trigger mode operation. In both modes, the SYNCSELx bits determine the Sync/Trigger source.

When the SYNCSELx bits are set to '00000' and ICTRIG is set, the module operates in Software Trigger mode. In this case, capture operations are started by manually setting the TRIGSTAT bit (ICxCON2[6]).

FIGURE 14-1: INPUT CAPTURE x BLOCK DIAGRAM

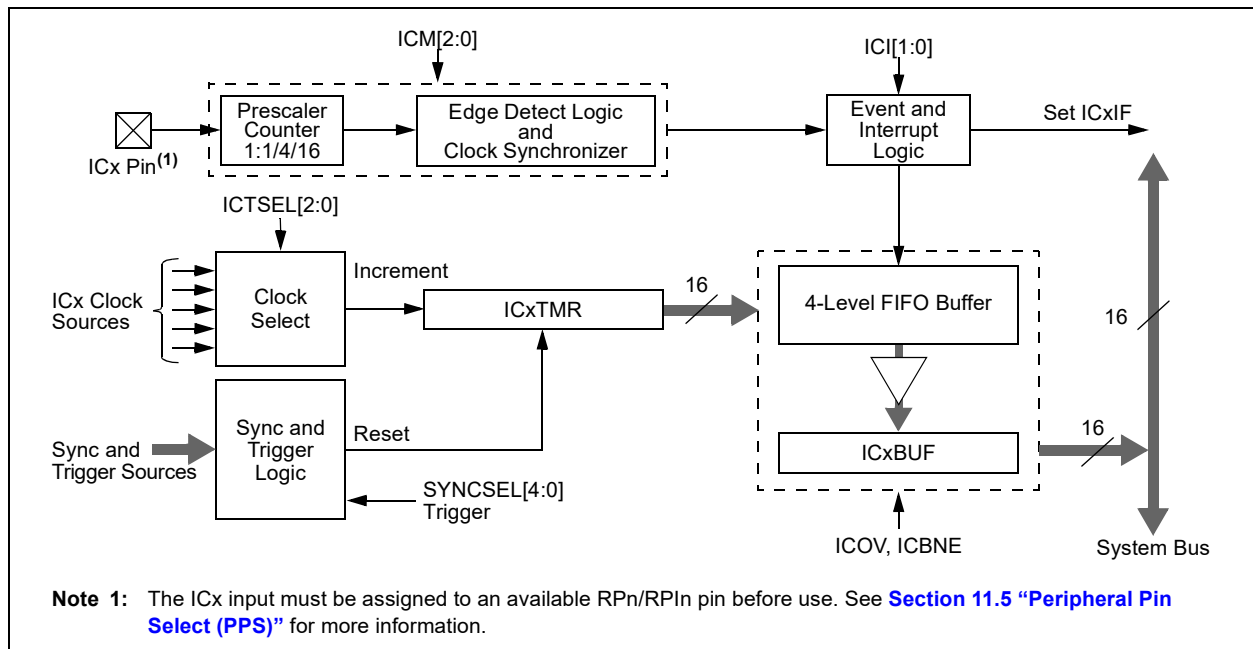

PIC24FJ256GA705 FAMILY

14.1.2 CASCADED (32-BIT) MODE

By default, each module operates independently with its own 16-bit timer. To increase resolution, adjacent even and odd modules can be configured to function as a single 32-bit module. (For example, Modules 1 and 2 are paired, as are Modules 3 and 4, and so on.) The odd numbered module (ICx) provides the Least Significant 16 bits of the 32-bit register pairs and the even numbered module (ICy) provides the Most Significant 16 bits. Wrap-arounds of the ICx registers cause an increment of their corresponding ICy registers.

Cascaded operation is configured in hardware by setting the IC32 bits (ICxCON2[8]) for both modules.

14.2 Capture Operations

The input capture module can be configured to capture timer values and generate interrupts on rising edges on ICx or all transitions on ICx. Captures can be configured to occur on all rising edges or just some (every 4th or 16th). Interrupts can be independently configured to generate on each event or a subset of events.

To set up the module for capture operations:

1. Configure the ICx input for one of the available Peripheral Pin Select pins.
2. If Synchronous mode is to be used, disable the Sync source before proceeding.
3. Make sure that any previous data have been removed from the FIFO by reading ICxBUF until the ICBNE bit (ICxCON1[3]) is cleared.
4. Set the SYNCSELx bits (ICxCON2[4:0]) to the desired Sync/Trigger source.
5. Set the ICTSELx bits (ICxCON1[12:10]) for the desired clock source.
6. Set the ICIX bits (ICxCON1[6:5]) to the desired interrupt frequency.
7. Select Synchronous or Trigger mode operation:
 - a) Check that the SYNCSELx bits are not set to '00000'.
 - b) For Synchronous mode, clear the ICTRIG bit (ICxCON2[7]).
 - c) For Trigger mode, set ICTRIG and clear the TRIGSTAT bit (ICxCON2[6]).
8. Set the ICMx bits (ICxCON1[2:0]) to the desired operational mode.
9. Enable the selected Sync/Trigger source.

For 32-bit cascaded operations, the setup procedure is slightly different:

1. Set the IC32 bits for both modules (ICyCON2[8] and ICxCON2[8]), enabling the even numbered module first. This ensures the modules will start functioning in unison.
2. Set the ICTSELx and SYNCSELx bits for both modules to select the same Sync/Trigger and time base source. Set the even module first, then the odd module. Both modules must use the same ICTSELx and SYNCSELx bits settings.
3. Clear the ICTRIG bit of the even module (ICyCON2[7]). This forces the module to run in Synchronous mode with the odd module, regardless of its Trigger mode setting.
4. Use the odd module's ICIX bits (ICxCON1[6:5]) to set the desired interrupt frequency.
5. Use the ICTRIG bit of the odd module (ICxCON2[7]) to configure Trigger or Synchronous mode operation.

Note: For Synchronous mode operation, enable the Sync source as the last step. Both input capture modules are held in Reset until the Sync source is enabled.

6. Use the ICMx bits of the odd module (ICxCON1[2:0]) to set the desired Capture mode.

The module is ready to capture events when the time base and the Sync/Trigger source are enabled. When the ICBNE bit (ICxCON1[3]) becomes set, at least one capture value is available in the FIFO. Read input capture values from the FIFO until the ICBNE clears to '0'.

For 32-bit operation, read both the ICxBUF and ICyBUF for the full 32-bit timer value (ICxBUF for the lsw, ICyBUF for the msw). At least one capture value is available in the FIFO buffer when the odd module's ICBNE bit (ICxCON1[3]) becomes set. Continue to read the buffer registers until ICBNE is cleared (performed automatically by hardware).

REGISTER 14-1: ICxCON1: INPUT CAPTURE x CONTROL REGISTER 1

U-0	U-0	R/W-0	R/W-0	R/W-0	R/W-0	U-0	U-0
—	—	ICSIDL	ICTSEL2	ICTSEL1	ICTSEL0	—	—
bit 15						bit 8	

U-0	R/W-0	R/W-0	HSC/R-0	HSC/R-0	R/W-0	R/W-0	R/W-0
—	ICI1	ICI0	ICOV	ICBNE	ICM2 ⁽¹⁾	ICM1 ⁽¹⁾	ICM0 ⁽¹⁾
bit 7							bit 0

Legend:	HSC = Hardware Settable/Clearable bit		
R = Readable bit	W = Writable bit	U = Unimplemented bit, read as '0'	
-n = Value at POR	'1' = Bit is set	'0' = Bit is cleared	x = Bit is unknown

bit 15-14 **Unimplemented:** Read as '0'

bit 13 **ICSIDL:** Input Capture x Stop in Idle Control bit
 1 = Input Capture x halts in CPU Idle mode
 0 = Input Capture x continues to operate in CPU Idle mode

bit 12-10 **ICTSEL[2:0]:** Input Capture x Timer Select bits
 111 = System clock (Fosc/2)
 110 = Reserved
 101 = Reserved
 100 = Timer1
 011 = Reserved
 010 = Reserved
 001 = Timer2
 000 = Timer3

bit 9-7 **Unimplemented:** Read as '0'

bit 6-5 **ICI[1:0]:** Input Capture x Select Number of Captures per Interrupt bits
 11 = Interrupt on every fourth capture event
 10 = Interrupt on every third capture event
 01 = Interrupt on every second capture event
 00 = Interrupt on every capture event

bit 4 **ICOV:** Input Capture x Overflow Status Flag bit (read-only)
 1 = Input Capture x overflow has occurred
 0 = No Input Capture x overflow has occurred

bit 3 **ICBNE:** Input Capture x Buffer Not Empty Status bit (read-only)
 1 = Input Capture x buffer is not empty, at least one more capture value can be read
 0 = Input Capture x buffer is empty

bit 2-0 **ICM[2:0]:** Input Capture x Mode Select bits⁽¹⁾
 111 = Interrupt mode: Input Capture x functions as an interrupt pin only when the device is in Sleep or Idle mode (rising edge detect only, all other control bits are not applicable)
 110 = Unused (module is disabled)
 101 = Prescaler Capture mode: Capture on every 16th rising edge
 100 = Prescaler Capture mode: Capture on every 4th rising edge
 011 = Simple Capture mode: Capture on every rising edge
 010 = Simple Capture mode: Capture on every falling edge
 001 = Edge Detect Capture mode: Capture on every edge (rising and falling); ICI[1:0] bits do not control interrupt generation for this mode
 000 = Input Capture x module is turned off

Note 1: The ICx input must also be configured to an available RPN/RPIn pin. For more information, see [Section 11.5 “Peripheral Pin Select \(PPS\)”](#).

PIC24FJ256GA705 FAMILY

REGISTER 14-2: ICxCON2: INPUT CAPTURE x CONTROL REGISTER 2

U-0	U-0	U-0	U-0	U-0	U-0	U-0	R/W-0
—	—	—	—	—	—	—	IC32
bit 15							bit 8

R/W-0	HS/R/W-0	U-0	R/W-0	R/W-1	R/W-1	R/W-0	R/W-1
ICTRIG	TRIGSTAT	—	SYNCSEL4	SYNCSEL3	SYNCSEL2	SYNCSEL1	SYNCSEL0
bit 7							bit 0

Legend:	HS = Hardware Settable bit		
R = Readable bit	W = Writable bit	U = Unimplemented bit, read as '0'	
-n = Value at POR	'1' = Bit is set	'0' = Bit is cleared	x = Bit is unknown

- bit 15-9 **Unimplemented:** Read as '0'
- bit 8 **IC32:** Cascade Two Input Capture Modules Enable bit (32-bit operation)
 - 1 = ICx and ICy operate in cascade as a 32-bit module (this bit must be set in both modules)
 - 0 = ICx functions independently as a 16-bit module
- bit 7 **ICTRIG:** Input Capture x Sync/Trigger Select bit
 - 1 = Triggers ICx from the source designated by the SYNCSELx bits
 - 0 = Synchronizes ICx with the source designated by the SYNCSELx bits
- bit 6 **TRIGSTAT:** Timer Trigger Status bit
 - 1 = Timer source has been triggered and is running (set in hardware, can be set in software)
 - 0 = Timer source has not been triggered and is being held clear
- bit 5 **Unimplemented:** Read as '0'

- Note 1:** Use these inputs as Trigger sources only and never as Sync sources.
- Note 2:** Never use an Input Capture x module as its own Trigger source by selecting this mode.

REGISTER 14-2: ICxCON2: INPUT CAPTURE x CONTROL REGISTER 2 (CONTINUED)

bit 4-0 **SYNCSEL[4:0]**: Synchronization/Trigger Source Selection bits

11111 = Not used
11110 = Not used
11101 = Not used
11100 = CTMU trigger⁽¹⁾
11011 = A/D interrupt⁽¹⁾
11010 = CMP3 trigger⁽¹⁾
11001 = CMP2 trigger⁽¹⁾
11000 = CMP1 trigger⁽¹⁾
10111 = Not used
10110 = MCCP4 IC/OC interrupt
10101 = MCCP3 IC/OC interrupt
10100 = MCCP2 IC/OC interrupt
10011 = MCCP1 IC/OC interrupt
10010 = IC3 interrupt⁽²⁾
10001 = IC2 interrupt⁽²⁾
10000 = IC1 interrupt⁽²⁾
01111 = Not used
01110 = Not used
01101 = Timer3 match event
01100 = Timer2 match event
01011 = Timer1 match event
01010 = Not used
01001 = Not used
01000 = Not used
00111 = MCCP4 Sync/Trigger out
00110 = MCCP3 Sync/Trigger out
00101 = MCCP2 Sync/Trigger out
00100 = MCCP1 Sync/Trigger out
00011 = OC3 Sync/Trigger out
00010 = OC2 Sync/Trigger out
00001 = OC1 Sync/Trigger out
00000 = Off

Note 1: Use these inputs as Trigger sources only and never as Sync sources.

2: Never use an Input Capture x module as its own Trigger source by selecting this mode.

PIC24FJ256GA705 FAMILY

NOTES:

15.0 OUTPUT COMPARE WITH DEDICATED TIMERS

Note: This data sheet summarizes the features of this group of PIC24F devices. It is not intended to be a comprehensive reference source. For more information, refer to **“Output Compare with Dedicated Timer”** (www.microchip.com/DS70005159) in the *“dsPIC33/PIC24 Family Reference Manual”*. The information in this data sheet supersedes the information in the FRM.

All devices in the PIC24FJ256GA705 family feature three independent output compare modules. Each of these modules offers a wide range of configuration and operating options for generating pulse trains on internal device events, and can produce Pulse-Width Modulated (PWM) waveforms for driving power applications.

Key features of the output compare module include:

- Hardware-Configurable for 32-Bit Operation in All modes by Cascading Two Adjacent modules
- Synchronous and Trigger modes of Output Compare Operation with up to 31 User-Selectable Sync/Trigger Sources Available
- Two Separate Period registers (a main register, OCxR, and a secondary register, OCxRS) for Greater Flexibility in Generating Pulses of Varying Widths
- Configurable for Single Pulse or Continuous Pulse Generation on an Output Event, or Continuous PWM Waveform Generation
- Up to Six Clock Sources Available for Each module, Driving a Separate Internal 16-Bit Counter

15.1 General Operating Modes

15.1.1 SYNCHRONOUS AND TRIGGER MODES

When the output compare module operates in a Free-Running mode, the internal 16-bit counter, OCxTMR, runs counts up continuously, wrapping around from 0xFFFF to 0x0000 on each overflow. Its period is synchronized to the selected external clock source. Compare or PWM events are generated each time a match between the internal counter and one of the Period registers occurs.

In Synchronous mode, the module begins performing its compare or PWM operation as soon as its selected clock source is enabled. Whenever an event occurs on the selected Sync source, the module's internal counter is reset. In Trigger mode, the module waits for a Sync event from another internal module to occur before allowing the counter to run.

Free-Running mode is selected by default or any time that the SYNCSEL[4:0] bits (OCxCON2[4:0]) are set to '00000'. Synchronous or Trigger modes are selected any time the SYNCSELx bits are set to any value except '00000'. The OCTRIG bit (OCxCON2[7]) selects either Synchronous or Trigger mode; setting the bit selects Trigger mode operation. In both modes, the SYNCSELx bits determine the Sync/Trigger source.

15.1.2 CASCADED (32-BIT) MODE

By default, each module operates independently with its own set of 16-Bit Timer and Duty Cycle registers. To increase resolution, adjacent even and odd modules can be configured to function as a single 32-bit module. (For example, Modules 1 and 2 are paired, as are Modules 3 and 4, and so on.) The odd numbered module (OCx) provides the Least Significant 16 bits of the 32-bit register pairs and the even numbered module (OCy) provides the Most Significant 16 bits. Wrap-arounds of the OCx registers cause an increment of their corresponding OCy registers.

Cascaded operation is configured in hardware by setting the OC32 bit (OCxCON2[8]) for both modules. For more details on cascading, refer to **“Output Compare with Dedicated Timer”** (www.microchip.com/DS70005159) in the *“dsPIC33/PIC24 Family Reference Manual”*.

PIC24FJ256GA705 FAMILY

FIGURE 15-1: OUTPUT COMPARE x BLOCK DIAGRAM (16-BIT MODE)

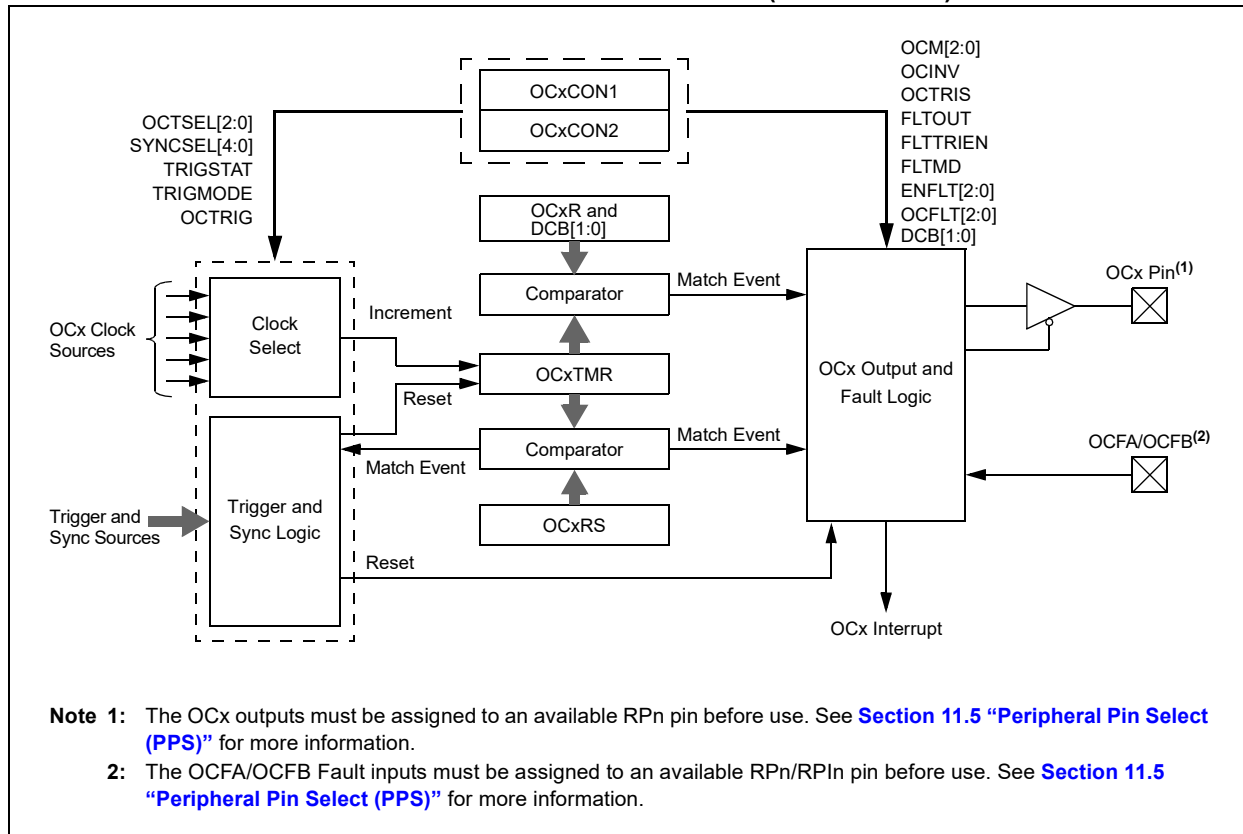

15.2 Compare Operations

In Compare mode (Figure 15-1), the output compare module can be configured for Single-Shot or Continuous mode pulse generation. It can also repeatedly toggle an output pin on each timer event.

To set up the module for compare operations:

- Configure the OCx output for one of the available Peripheral Pin Select pins if available on the OCx module you are using. Otherwise, configure the dedicated OCx output pins.
- Calculate the required values for the OCxR and (for Double Compare modes) OCxRS Duty Cycle registers:
 - Determine the instruction clock cycle time. Take into account the frequency of the external clock to the timer source (if one is used) and the timer prescaler settings.
 - Calculate the time to the rising edge of the output pulse relative to the timer start value (0000h).
 - Calculate the time to the falling edge of the pulse based on the desired pulse width and the time to the rising edge of the pulse.
- Write the rising edge value to OCxR and the falling edge value to OCxRS.
- Set the Timer Period register, PRy, to a value equal to or greater than the value in OCxRS.
- Set the OCM[2:0] bits for the appropriate compare operation (= 0xx).
- For Trigger mode operations, set OCTRIG to enable Trigger mode. Set or clear TRIGMODE to configure Trigger mode operation and TRIGSTAT to select a hardware or software trigger. For Synchronous mode, clear OCTRIG.
- Set the SYNCSEL[4:0] bits to configure the Trigger or Sync source. If free-running timer operation is required, set the SYNCSELx bits to '00000' (no Sync/Trigger source).
- Select the time base source with the OCTSEL[2:0] bits. If necessary, set the TON bit for the selected timer, which enables the compare time base to count. Synchronous mode operation starts as soon as the time base is enabled; Trigger mode operation starts after a Trigger source event occurs.

For 32-bit cascaded operation, these steps are also necessary:

1. Set the OC32 bits for both registers (OCyCON2[8] and OCxCON2[8]). Enable the even numbered module first to ensure the modules will start functioning in unison.
2. Clear the OCTRIG bit of the even module (OCyCON2[7]), so the module will run in Synchronous mode.
3. Configure the desired output and Fault settings for OCy.
4. Force the output pin for OCx to the Output state by clearing the OCTRIS bit.
5. If Trigger mode operation is required, configure the Trigger options in OCx by using the OCTRIG (OCxCON2[7]), TRIGMODE (OCxCON1[3]) and SYNCSEL[4:0] (OCxCON2[4:0]) bits.
6. Configure the desired Compare or PWM mode of operation (OCM[2:0]) for OCy first, then for OCx.

Depending on the output mode selected, the module holds the OCx pin in its Default state and forces a transition to the opposite state when OCxR matches the timer. In Double Compare modes, OCx is forced back to its Default state when a match with OCxRS occurs. The OCxIF interrupt flag is set after an OCxR match in Single Compare modes and after each OCxRS match in Double Compare modes.

Single-Shot pulse events only occur once, but may be repeated by simply rewriting the value of the OCxCON1 register. Continuous pulse events continue indefinitely until terminated.

15.3 Pulse-Width Modulation (PWM) Mode

In PWM mode, the output compare module can be configured for edge-aligned or center-aligned pulse waveform generation. All PWM operations are double-buffered (buffer registers are internal to the module and are not mapped into SFR space).

To configure the output compare module for PWM operation:

1. Configure the OCx output for one of the available Peripheral Pin Select pins if available on the OC module you are using. Otherwise, configure the dedicated OCx output pins.
2. Calculate the desired duty cycles and load them into the OCxR register.
3. Calculate the desired period and load it into the OCxRS register.
4. Select the current OCx as the synchronization source by writing '0x1F' to the SYNCSEL[4:0] bits (OCxCON2[4:0]) and '0' to the OCTRIG bit (OCxCON2[7]).
5. Select a clock source by writing to the OCTSEL[2:0] bits (OCxCON1[12:10]).
6. Enable interrupts, if required, for the timer and output compare modules. The output compare interrupt is required for PWM Fault pin utilization.
7. Select the desired PWM mode in the OCM[2:0] bits (OCxCON1[2:0]).
8. Appropriate Fault inputs may be enabled by using the ENFLT[2:0] bits as described in [Register 15-1](#).
9. If a timer is selected as a clock source, set the selected timer prescale value. The selected timer's prescaler output is used as the clock input for the OCx timer and not the selected timer output.

Note: This peripheral contains input and output functions that may need to be configured by the Peripheral Pin Select. See [Section 11.5 "Peripheral Pin Select \(PPS\)"](#) for more information.

PIC24FJ256GA705 FAMILY

FIGURE 15-2: OUTPUT COMPARE x BLOCK DIAGRAM (DOUBLE-BUFFERED, 16-BIT PWM MODE)

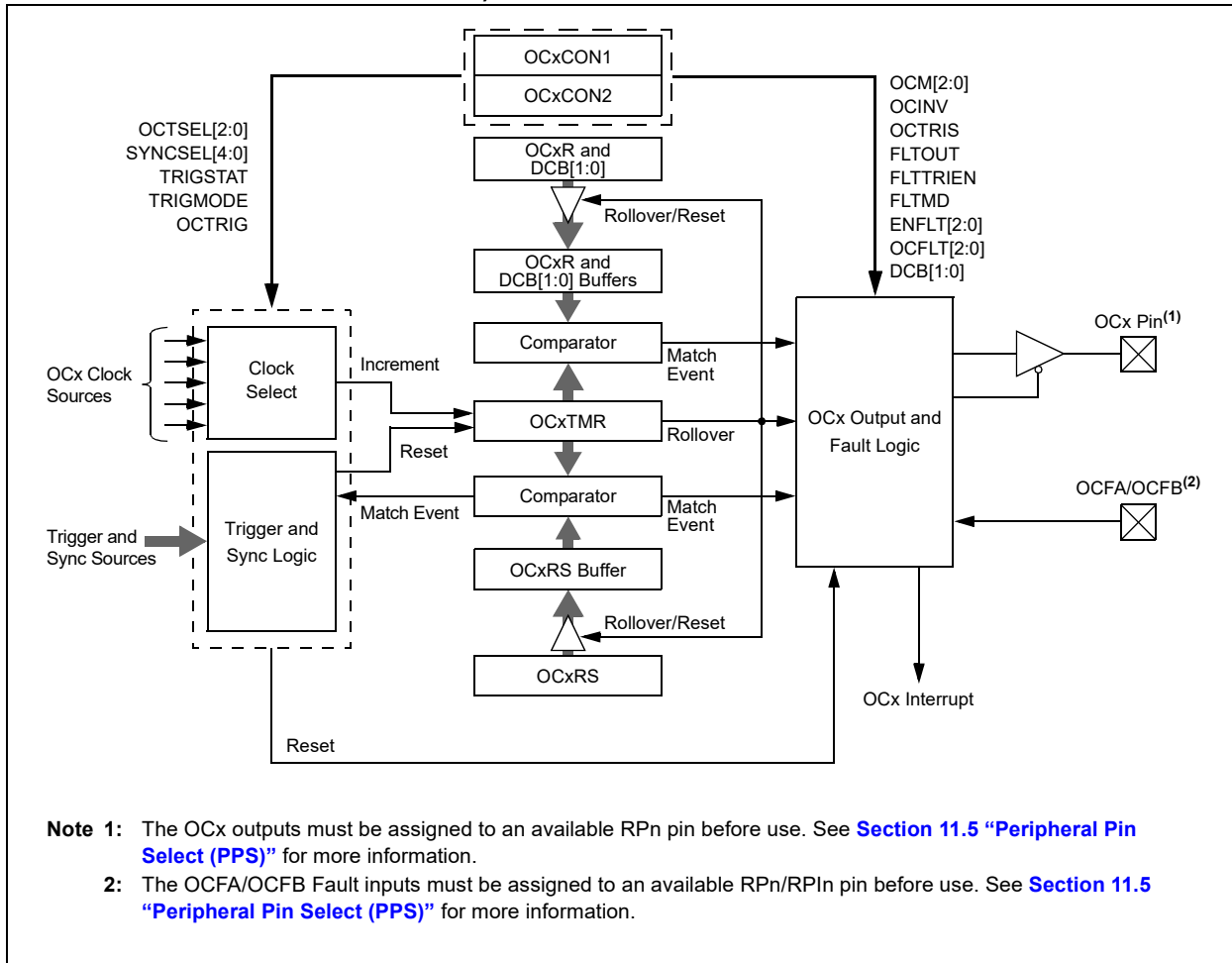

15.3.1 PWM PERIOD

The PWM period is specified by writing to PRy, the Timer Period register. The PWM period can be calculated using [Equation 15-1](#).

EQUATION 15-1: CALCULATING THE PWM PERIOD⁽¹⁾

$$\text{PWM Period} = [(PRy) + 1] \cdot T_{CY} \cdot (\text{Timer Prescale Value})$$

Where:

$$\text{PWM Frequency} = 1/[\text{PWM Period}]$$

Note 1: Based on $T_{CY} = T_{OSC} \cdot 2$; Doze mode and PLL are disabled.

Note: A PRy value of N will produce a PWM period of N + 1 time base count cycles. For example, a value of seven, written into the PRy register, will yield a period consisting of eight time base cycles.

15.3.2 PWM DUTY CYCLE

The PWM duty cycle is specified by writing to the OCxRS and OCxR registers. The OCxRS and OCxR registers can be written to at any time, but the duty cycle value is not latched until a match between PRy and TMRy occurs (i.e., the period is complete). This provides a double buffer for the PWM duty cycle and is essential for glitchless PWM operation.

Some important boundary parameters of the PWM duty cycle include:

- If OCxR, OCxRS and PRy are all loaded with 0000h, the OCx pin will remain low (0% duty cycle).
- If OCxRS is greater than PRy, the pin will remain high (100% duty cycle).

See [Example 15-1](#) for PWM mode timing details. [Table 15-1](#) and [Table 15-2](#) show example PWM frequencies and resolutions for a device operating at 4 MIPS and 10 MIPS, respectively.

EQUATION 15-2: CALCULATION FOR MAXIMUM PWM RESOLUTION⁽¹⁾

$$\text{Maximum PWM Resolution (bits)} = \frac{\log_{10} \left(\frac{F_{CY}}{F_{PWM} \cdot (\text{Timer Prescale Value})} \right)}{\log_{10}(2)} \text{ bits}$$

Note 1: Based on $F_{CY} = F_{OSC}/2$; Doze mode and PLL are disabled.

EXAMPLE 15-1: PWM PERIOD AND DUTY CYCLE CALCULATIONS⁽¹⁾

1. Find the Timer Period register value for a desired PWM frequency of 52.08 kHz, where $F_{OSC} = 32$ MHz with PLL (32 MHz device clock rate) and a Timer2 prescaler setting of 1:1.

$$T_{CY} = 2 \cdot T_{OSC} = 62.5 \text{ ns}$$

$$\text{PWM Period} = 1/\text{PWM Frequency} = 1/52.08 \text{ kHz} = 19.2 \text{ }\mu\text{S}$$

$$\text{PWM Period} = (PR2 + 1) \cdot T_{CY} \cdot (\text{Timer2 Prescale Value})$$

$$19.2 \text{ }\mu\text{S} = (PR2 + 1) \cdot 62.5 \text{ ns} \cdot 1$$

$$PR2 = 306$$

2. Find the maximum resolution of the duty cycle that can be used with a 52.08 kHz frequency and a 32 MHz device clock rate:

$$\text{PWM Resolution} = \log_{10}(F_{CY}/F_{PWM})/\log_{10}(2) \text{ bits}$$

$$= (\log_{10}(16 \text{ MHz}/52.08 \text{ kHz})/\log_{10}(2)) \text{ bits}$$

$$= 8.3 \text{ bits}$$

Note 1: Based on $T_{CY} = 2 \cdot T_{OSC}$; Doze mode and PLL are disabled.

TABLE 15-1: EXAMPLE PWM FREQUENCIES AND RESOLUTIONS AT 4 MIPS ($F_{CY} = 4$ MHz)⁽¹⁾

PWM Frequency	7.6 Hz	61 Hz	122 Hz	977 Hz	3.9 kHz	31.3 kHz	125 kHz
Timer Prescaler Ratio	8	1	1	1	1	1	1
Period Register Value	FFFFh	FFFFh	7FFFh	0FFFh	03FFh	007Fh	001Fh
Resolution (bits)	16	16	15	12	10	7	5

Note 1: Based on $F_{CY} = F_{OSC}/2$; Doze mode and PLL are disabled.

TABLE 15-2: EXAMPLE PWM FREQUENCIES AND RESOLUTIONS AT 16 MIPS ($F_{CY} = 16$ MHz)⁽¹⁾

PWM Frequency	30.5 Hz	244 Hz	488 Hz	3.9 kHz	15.6 kHz	125 kHz	500 kHz
Timer Prescaler Ratio	8	1	1	1	1	1	1
Period Register Value	FFFFh	FFFFh	7FFFh	0FFFh	03FFh	007Fh	001Fh
Resolution (bits)	16	16	15	12	10	7	5

Note 1: Based on $F_{CY} = F_{OSC}/2$; Doze mode and PLL are disabled.

PIC24FJ256GA705 FAMILY

REGISTER 15-1: OCxCON1: OUTPUT COMPARE x CONTROL REGISTER 1

U-0	U-0	R/W-0	R/W-0	R/W-0	R/W-0	R/W-0	R/W-0
—	—	OCSIDL	OCTSEL2	OCTSEL1	OCTSEL0	ENFLT2 ⁽²⁾	ENFLT1 ⁽²⁾
bit 15						bit 8	

R/W-0	HSC/R/W-0	HSC/R/W-0	HSC/R/W-0	R/W-0	R/W-0	R/W-0	R/W-0
ENFLT0 ⁽²⁾	OCFLT2 ^(2,3)	OCFLT1 ^(2,4)	OCFLT0 ^(2,4)	TRIGMODE	OCM2 ⁽¹⁾	OCM1 ⁽¹⁾	OCM0 ⁽¹⁾
bit 7						bit 0	

Legend:	HSC = Hardware Settable/Clearable bit		
R = Readable bit	W = Writable bit	U = Unimplemented bit, read as '0'	
-n = Value at POR	'1' = Bit is set	'0' = Bit is cleared	x = Bit is unknown

- bit 15-14 **Unimplemented:** Read as '0'
- bit 13 **OCSIDL:** Output Compare x Stop in Idle Mode Control bit
 - 1 = Output Compare x halts in CPU Idle mode
 - 0 = Output Compare x continues to operate in CPU Idle mode
- bit 12-10 **OCTSEL[2:0]:** Output Compare x Timer Select bits
 - 111 = Peripheral clock (FCY)
 - 110 = Reserved
 - 101 = Reserved
 - 100 = Timer1 clock (only synchronous clock is supported)
 - 011 = Unimplemented
 - 010 = Unimplemented
 - 001 = Timer3 clock
 - 000 = Timer2 clock
- bit 9 **ENFLT2:** Fault Input 2 Enable bit⁽²⁾
 - 1 = Fault 2 (Comparator 1/2/3 out) is enabled⁽³⁾
 - 0 = Fault 2 is disabled
- bit 8 **ENFLT1:** Fault Input 1 Enable bit⁽²⁾
 - 1 = Fault 1 (OCFB pin) is enabled⁽⁴⁾
 - 0 = Fault 1 is disabled
- bit 7 **ENFLT0:** Fault Input 0 Enable bit⁽²⁾
 - 1 = Fault 0 (OCFA pin) is enabled⁽⁴⁾
 - 0 = Fault 0 is disabled
- bit 6 **OCFLT2:** Output Compare x PWM Fault 2 (Comparator 1/2/3) Condition Status bit^(2,3)
 - 1 = PWM Fault 2 has occurred
 - 0 = No PWM Fault 2 has occurred
- bit 5 **OCFLT1:** Output Compare x PWM Fault 1 (OCFB pin) Condition Status bit^(2,4)
 - 1 = PWM Fault 1 has occurred
 - 0 = No PWM Fault 1 has occurred
- bit 4 **OCFLT0:** PWM Fault 0 (OCFA pin) Condition Status bit^(2,4)
 - 1 = PWM Fault 0 has occurred
 - 0 = No PWM Fault 0 has occurred

- Note 1:** The OCx output must also be configured to an available RPN pin. For more information, see [Section 11.5 “Peripheral Pin Select \(PPS\)”](#).
- 2:** The Fault input enable and Fault status bits are valid when OCM[2:0] = 111 or 110.
- 3:** The Comparator 1 output controls the OC1-OC3 channels.
- 4:** The OCFA/OCFB Fault input must also be configured to an available RPN/RPIN pin. For more information, see [Section 11.5 “Peripheral Pin Select \(PPS\)”](#).

REGISTER 15-1: OCxCON1: OUTPUT COMPARE x CONTROL REGISTER 1 (CONTINUED)

- bit 3 **TRIGMODE:** Trigger Status Mode Select bit
1 = TRIGSTAT (OCxCON2[6]) is cleared when OCxRS = OCxTMR or in software
0 = TRIGSTAT is only cleared by software
- bit 2-0 **OCM[2:0]:** Output Compare x Mode Select bits⁽¹⁾
111 = Center-Aligned PWM mode on OCx⁽²⁾
110 = Edge-Aligned PWM mode on OCx⁽²⁾
101 = Double-Compare Continuous Pulse mode: Initializes the OCx pin low; toggles the OCx state continuously on alternate matches of OCxR and OCxRS
100 = Double-Compare Single-Shot mode: Initializes the OCx pin low; toggles the OCx state on matches of OCxR and OCxRS for one cycle
011 = Single Compare Continuous Pulse mode: Compare events continuously toggle the OCx pin
010 = Single Compare Single-Shot mode: Initializes OCx pin high; compare event forces the OCx pin low
001 = Single Compare Single-Shot mode: Initializes OCx pin low; compare event forces the OCx pin high
000 = Output compare channel is disabled

- Note 1:** The OCx output must also be configured to an available RPN pin. For more information, see [Section 11.5 “Peripheral Pin Select \(PPS\)”](#).
- 2:** The Fault input enable and Fault status bits are valid when OCM[2:0] = 111 or 110.
- 3:** The Comparator 1 output controls the OC1-OC3 channels.
- 4:** The OCFA/OCFB Fault input must also be configured to an available RPN/RPN pin. For more information, see [Section 11.5 “Peripheral Pin Select \(PPS\)”](#).

PIC24FJ256GA705 FAMILY

REGISTER 15-2: OCxCON2: OUTPUT COMPARE x CONTROL REGISTER 2

R/W-0	R/W-0	R/W-0	R/W-0	U-0	R/W-0	R/W-0	R/W-0
FLTMD	FLTOUT	FLTRIEN	OCINV	—	DCB1 ⁽³⁾	DCB0 ⁽³⁾	OC32
bit 15						bit 8	

R/W-0	HS/R/W-0	R/W-0	R/W-0	R/W-1	R/W-1	R/W-0	R/W-0
OCTRIG	TRIGSTAT	OCTRIS	SYNCSEL4	SYNCSEL3	SYNCSEL2	SYNCSEL1	SYNCSEL0
bit 7						bit 0	

Legend:	HS = Hardware Settable bit		
R = Readable bit	W = Writable bit	U = Unimplemented bit, read as '0'	
-n = Value at POR	'1' = Bit is set	'0' = Bit is cleared	x = Bit is unknown

- bit 15 **FLTMD:** Fault Mode Select bit
 1 = Fault mode is maintained until the Fault source is removed and the corresponding OCFLT0 bit is cleared in software
 0 = Fault mode is maintained until the Fault source is removed and a new PWM period starts
- bit 14 **FLTOUT:** Fault Out bit
 1 = PWM output is driven high on a Fault
 0 = PWM output is driven low on a Fault
- bit 13 **FLTRIEN:** Fault Output State Select bit
 1 = Pin is forced to an output on a Fault condition
 0 = Pin I/O condition is unaffected by a Fault
- bit 12 **OCINV:** OCMP Invert bit
 1 = OCx output is inverted
 0 = OCx output is not inverted
- bit 11 **Unimplemented:** Read as '0'
- bit 10-9 **DCB[1:0]:** PWM Duty Cycle Least Significant bits⁽³⁾
 11 = Delays OCx falling edge by $\frac{3}{4}$ of the instruction cycle
 10 = Delays OCx falling edge by $\frac{1}{2}$ of the instruction cycle
 01 = Delays OCx falling edge by $\frac{1}{4}$ of the instruction cycle
 00 = OCx falling edge occurs at the start of the instruction cycle
- bit 8 **OC32:** Cascade Two OC Modules Enable bit (32-bit operation)
 1 = Cascade module operation is enabled
 0 = Cascade module operation is disabled
- bit 7 **OCTRIG:** OCx Trigger/Sync Select bit
 1 = Triggers OCx from the source designated by the SYNCSELx bits
 0 = Synchronizes OCx with the source designated by the SYNCSELx bits
- bit 6 **TRIGSTAT:** Timer Trigger Status bit
 1 = Timer source has been triggered and is running
 0 = Timer source has not been triggered and is being held clear
- bit 5 **OCTRIS:** OCx Output Pin Direction Select bit
 1 = OCx pin is tri-stated
 0 = Output Compare Peripheral x is connected to an OCx pin

- Note 1:** Never use an Output Compare x module as its own Trigger source, either by selecting this mode or another equivalent SYNCSELx setting.
- 2:** Use these inputs as Trigger sources only and never as Sync sources.
- 3:** The DCB[1:0] bits are double-buffered in the PWM modes only (OCM[2:0] (OCxCON1[2:0]) = 111, 110).

REGISTER 15-2: OCxCON2: OUTPUT COMPARE x CONTROL REGISTER 2 (CONTINUED)

bit 4-0	SYNCSEL[4:0]: Trigger/Synchronization Source Selection bits
	11111 = OCx Sync out ⁽¹⁾
	11110 = OCTRIG1 pin
	11101 = OCTRIG2 pin
	11100 = CTMU trigger ⁽²⁾
	11011 = A/D interrupt ⁽²⁾
	11010 = CMP3 trigger ⁽²⁾
	11001 = CMP2 trigger ⁽²⁾
	11000 = CMP1 trigger ⁽²⁾
	10111 = Not used
	10110 = MCCP4 IC/OC interrupt
	10101 = MCCP3 IC/OC interrupt
	10100 = MCCP2 IC/OC interrupt
	10011 = MCCP1 IC/OC interrupt
	10010 = IC3 interrupt ⁽²⁾
	10001 = IC2 interrupt ⁽²⁾
	10000 = IC1 interrupt ⁽²⁾
	01111 = Not used
	01110 = Not used
	01101 = Timer3 match event
	01100 = Timer2 match event (default)
	01011 = Timer1 match event
	01010 = Not used
	01001 = Not used
	01000 = Not used
	00111 = MCCP4 Sync/Trigger out
	00110 = MCCP3 Sync/Trigger out
	00101 = MCCP2 Sync/Trigger out
	00100 = MCCP1 Sync/Trigger out
	00011 = Not used
	00010 = OC3 Sync/Trigger out ⁽¹⁾
	00001 = OC1 Sync/Trigger out ⁽¹⁾
	00000 = Off, Free-Running mode with no synchronization and rollover at FFFFh

- Note 1:** Never use an Output Compare x module as its own Trigger source, either by selecting this mode or another equivalent SYNCSELx setting.
- 2:** Use these inputs as Trigger sources only and never as Sync sources.
- 3:** The DCB[1:0] bits are double-buffered in the PWM modes only (OCM[2:0] (OCxCON1[2:0]) = 111, 110).

PIC24FJ256GA705 FAMILY

NOTES:

16.0 CAPTURE/COMPARE/PWM/TIMER MODULES (MCCP)

Note: This data sheet summarizes the features of this group of PIC24F devices. It is not intended to be a comprehensive reference source. For more information, refer to “**Capture/Compare/PWM/Timer (MCCP and S CCP)**” (www.microchip.com/DS30003035) in the “*dsPIC33/PIC24 Family Reference Manual*”. The information in this data sheet supersedes the information in the FRM.

PIC24FJ256GA705 family devices include several Capture/Compare/PWM/Timer base modules, which provide the functionality of three different peripherals of earlier PIC24F devices. The module can operate in one of three major modes:

- General Purpose Timer
- Input Capture
- Output Compare/PWM

This family of devices features four instances of the MCCP module. MCCP1 provides up to six outputs and an extended range of power control features, whereas MCCP2-MCCP4 support two outputs.

The MCCPx modules can be operated only in one of the three major modes at any time. The other modes are not available unless the module is reconfigured for the new mode.

A conceptual block diagram for the module is shown in [Figure 16-1](#). All three modules share a time base generator and a common Timer register pair (CCPxTMRH/L); other shared hardware components are added as a particular mode requires.

Each module has a total of seven control and status registers:

- CCPxCON1L ([Register 16-1](#))
- CCPxCON1H ([Register 16-2](#))
- CCPxCON2L ([Register 16-3](#))
- CCPxCON2H ([Register 16-4](#))
- CCPxCON3L ([Register 16-5](#))
- CCPxCON3H ([Register 16-6](#))
- CCPxSTATL ([Register 16-7](#))

Each module also includes ten buffer/counter registers that serve as Timer Value registers or data holding buffers:

- CCPxTMRH/CCPxTMRL (Timer High/Low Counters)
- CCPxPRH/CCPxPRL (Timer Period High/Low)
- CCPxRAH/CCPxRAL (Primary Output Compare Data High/Low Buffer)
- CCPxRBH/CCPxRBL (Secondary Output Compare Data High/Low Buffer)
- CCPxBUFH/CCPxBUFL (Input Capture High/Low Buffers)

FIGURE 16-1: MCCPx CONCEPTUAL BLOCK DIAGRAM

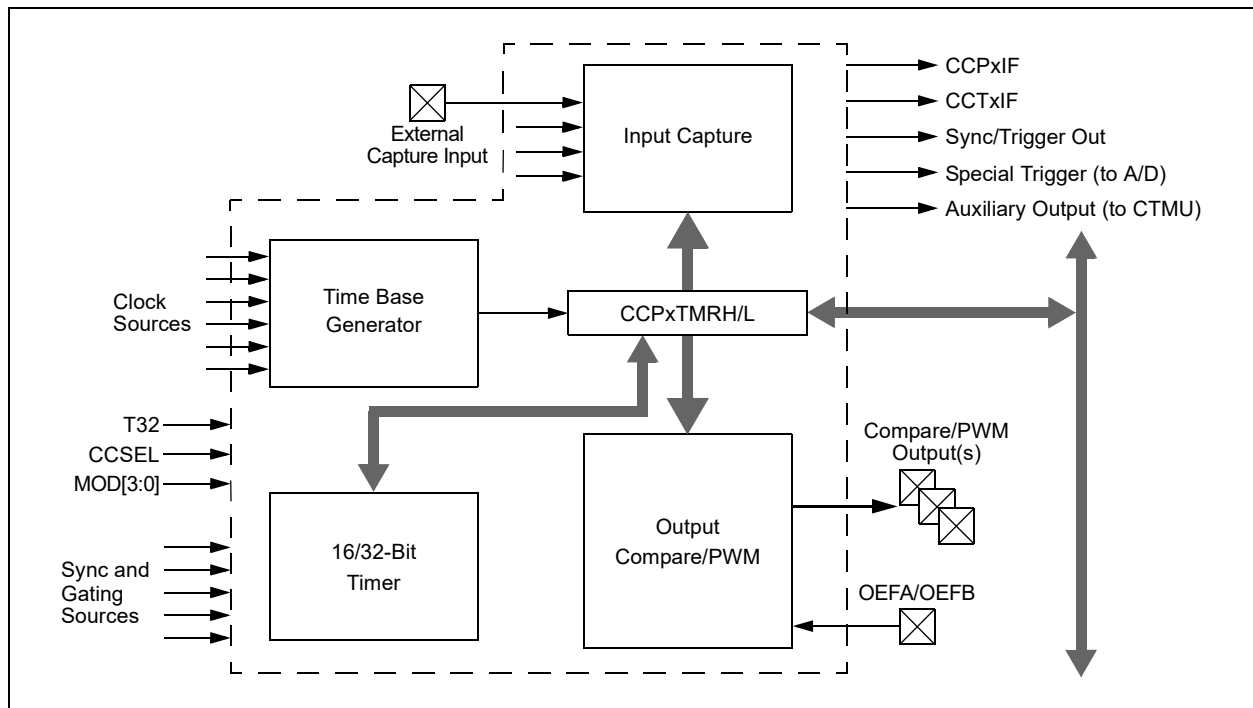

PIC24FJ256GA705 FAMILY

16.1 Time Base Generator

The Timer Clock Generator (TCG) generates a clock for the module's internal time base using one of the clock signals already available on the microcontroller. This is used as the time reference for the module in its three major modes. The internal time base is shown in Figure 16-2.

There are eight inputs available to the clock generator, which are selected using the CLKSEL[2:0] bits (CCPxCON1L[10:8]). Available sources include the FRC and LPRC, the Secondary Oscillator and the TCLKI external clock inputs. The system clock is the default source (CLKSEL[2:0] = 000). On PIC24FJ256GA705 family devices, clock sources to the MCCPx module must be synchronized with the system clock. As a result, when clock sources are selected, clock input timing restrictions or module operating restrictions may exist.

FIGURE 16-2: TIMER CLOCK GENERATOR

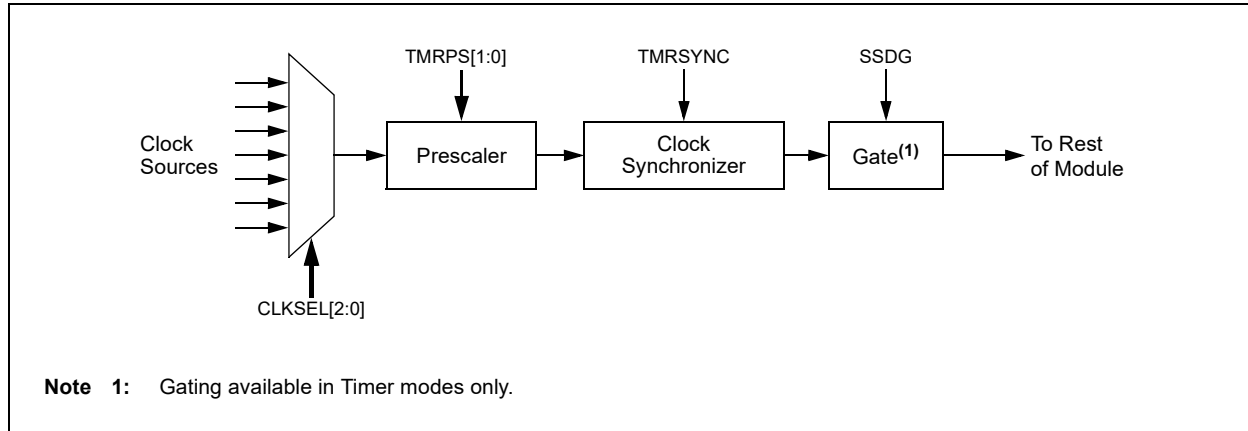

16.2 General Purpose Timer

Timer mode is selected when $CCSEL = 0$ and $MOD[3:0] = 0000$. The timer can function as a 32-bit timer or a dual 16-bit timer, depending on the setting of the T32 bit (Table 16-1).

TABLE 16-1: TIMER OPERATION MODE

T32 (CCPxCON1L[5])	Operating Mode
0	Dual Timer Mode (16-bit)
1	Timer Mode (32-bit)

Dual 16-Bit Timer mode provides a simple timer function with two independent 16-bit timer/counters. The primary timer uses the CCPxTMRL and CCPxPRL registers. Only the primary timer can interact with other modules on the device. It generates the MCCPx Sync out signals for use by other MCCPx modules. It can also use the SYNC[4:0] bits signal generated by other modules.

The secondary timer uses the CCPxTMRH and CCPxPRH registers. It is intended to be used only as a periodic interrupt source for scheduling CPU events. It does not generate an output Sync/Trigger signal like the primary time base. In Dual Timer mode, the Timer Period High register, CCPxPRH, generates the MCCPx compare event (CCPxIF) used by many other modules on the device.

The 32-Bit Timer mode uses the CCPxTMRL and CCPxTMRH registers, together, as a single 32-bit timer. When CCPxTMRL overflows, CCPxTMRH increments

by one. This mode provides a simple timer function when it is important to track long time periods. Note that the T32 bit (CCPxCON1L[5]) should be set before the CCPxTMRL or CCPxPRH registers are written to initialize the 32-bit timer.

16.2.1 SYNC AND TRIGGER OPERATION

In both 16-bit and 32-bit modes, the timer can also function in either Synchronization (“Sync”) or Trigger mode operation. Both use the SYNC[4:0] bits (CCPxCON1H[4:0]) to determine the input signal source. The difference is how that signal affects the timer.

In Sync operation, the Timer Reset or clear occurs when the input selected by SYNC[4:0] is asserted. The timer immediately begins to count again from zero unless it is held for some other reason. Sync operation is used whenever the TRIGEN bit (CCPxCON1H[7]) is cleared. The SYNC[4:0] bits can have any value except ‘11111’.

In Trigger mode operation, the timer is held in Reset until the input selected by SYNC[4:0] is asserted; when it occurs, the timer starts counting. Trigger operation is used whenever the TRIGEN bit is set. In Trigger mode, the timer will continue running after a trigger event as long as the CCPTRIG bit (CCPxSTATL[7]) is set. To clear CCPTRIG, the TRCLR bit (CCPxSTATL[5]) must be set to clear the trigger event, reset the timer and hold it at zero until another trigger event occurs. On PIC24FJ256GA705 family devices, Trigger mode operation can only be used when the system clock is the time base source (CLKSEL[2:0] = 000).

FIGURE 16-3: DUAL 16-BIT TIMER MODE

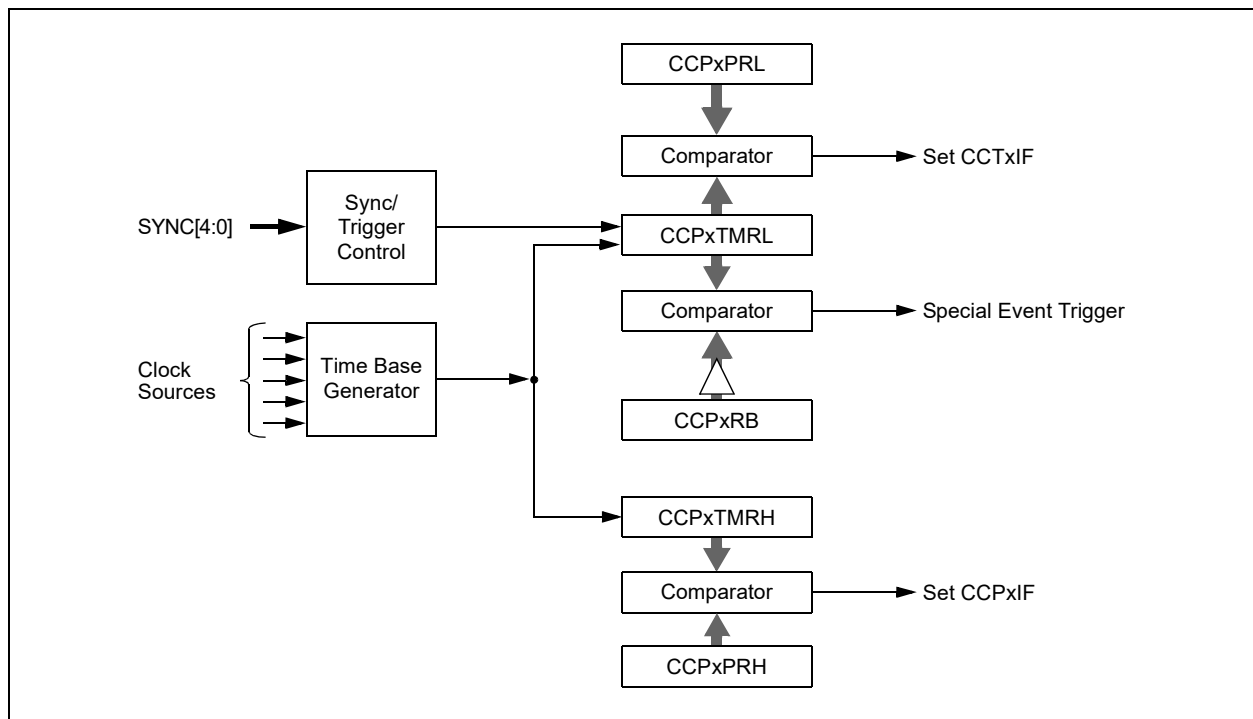

PIC24FJ256GA705 FAMILY

FIGURE 16-4: 32-BIT TIMER MODE

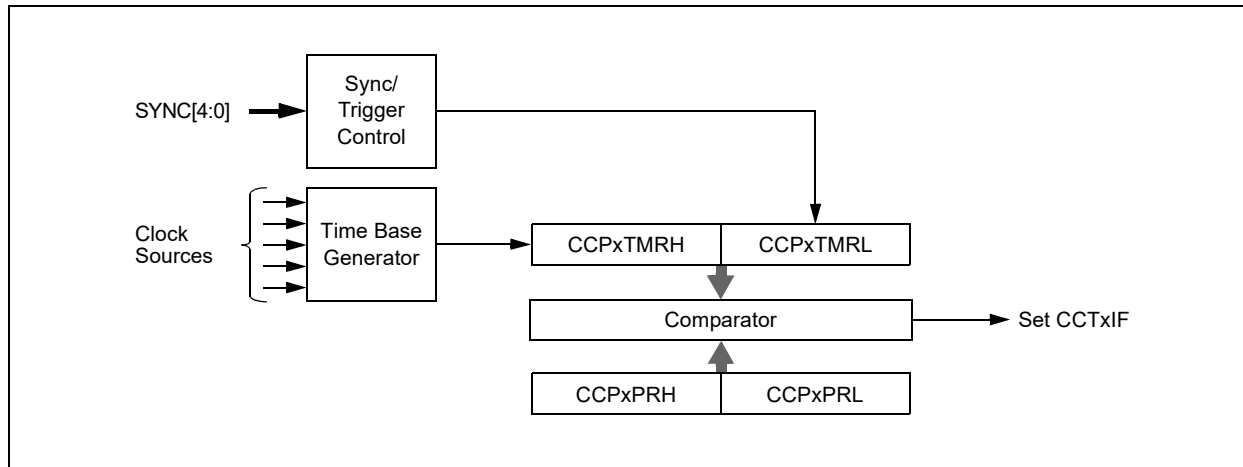

16.3 Output Compare Mode

Output Compare mode compares the Timer register value with the value of one or two Compare registers, depending on its mode of operation. The Output Compare x module, on compare match events, has the ability to generate a single output transition or a train of

output pulses. Like most PIC® MCU peripherals, the Output Compare x module can also generate interrupts on a compare match event.

Table 16-2 shows the various modes available in Output Compare modes.

TABLE 16-2: OUTPUT COMPARE/PWM MODES

MOD[3:0] (CCPxCON1L[3:0])	T32 (CCPxCON1L[5])	Operating Mode	
0001	0	Output High on Compare (16-bit)	Single Edge Mode
0001	1	Output High on Compare (32-bit)	
0010	0	Output Low on Compare (16-bit)	
0010	1	Output Low on Compare (32-bit)	
0011	0	Output Toggle on Compare (16-bit)	
0011	1	Output Toggle on Compare (32-bit)	
0100	0	Dual Edge Compare (16-bit)	Dual Edge Mode
0101	0	Dual Edge Compare (16-bit buffered)	PWM Mode
0110	0	Center-Aligned Pulse (16-bit buffered) ⁽¹⁾	Center PWM Mode
0111	0	Variable Frequency Pulse (16-bit)	
1111	0	External Input Source Mode (16-bit)	

Note 1: Center-Aligned PWM mode is only available on MCCP modules. This feature is disabled on SCCP modules.

FIGURE 16-5: OUTPUT COMPARE x BLOCK DIAGRAM

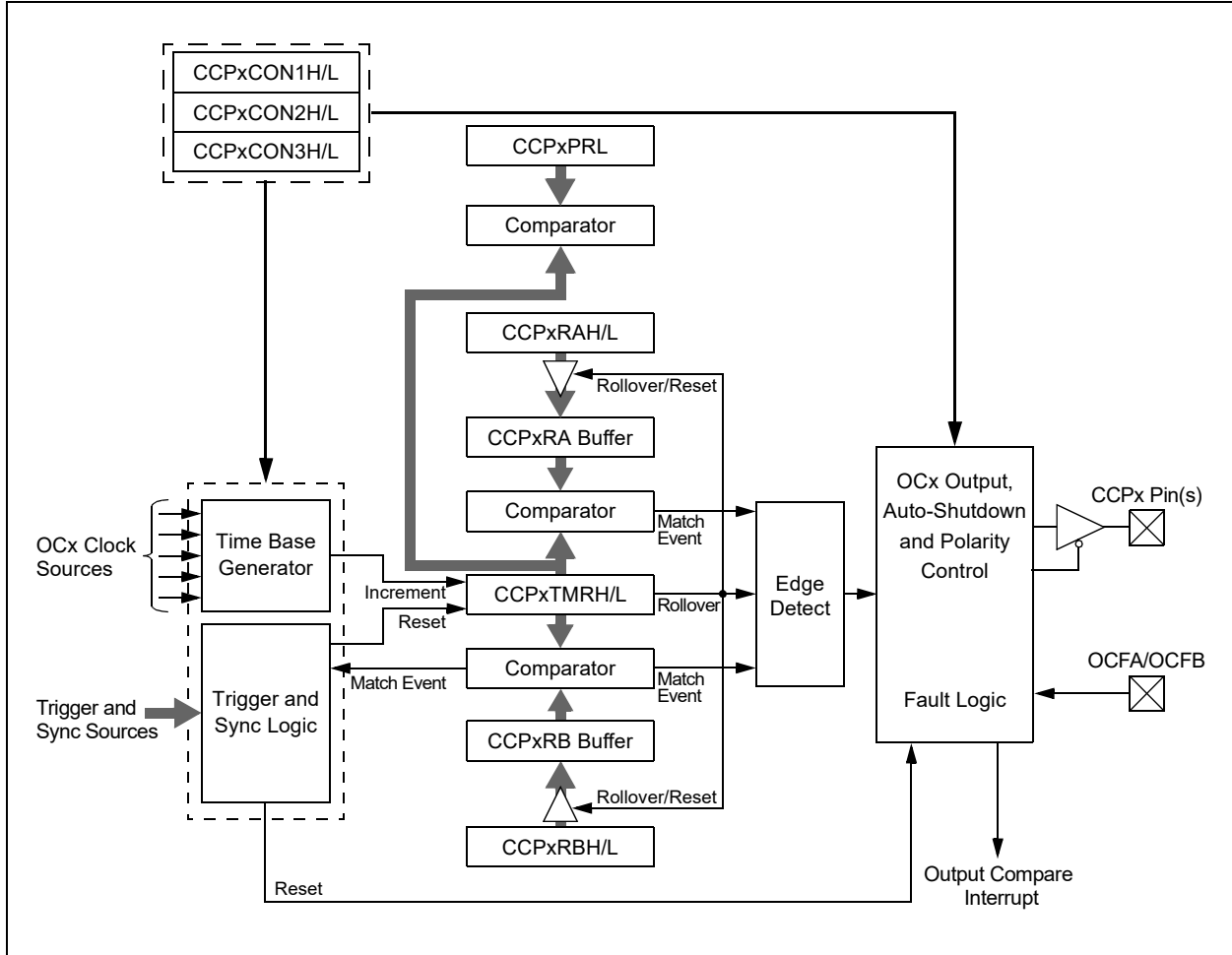

PIC24FJ256GA705 FAMILY

16.4 Input Capture Mode

Input Capture mode is used to capture a timer value from an independent timer base upon an event on an input pin or other internal Trigger source. The input capture features are useful in applications requiring frequency (time period) and pulse measurement. Figure 16-6 depicts a simplified block diagram of the Input Capture mode.

Input Capture mode uses a dedicated 16/32-bit, synchronous, up counting timer for the capture function. The timer value is written to the FIFO when a capture event occurs. The internal value may be read (with a synchronization delay) using the CCPxTMRH/L registers.

To use Input Capture mode, the CCSEL bit (CCPxCON1L[4]) must be set. The T32 and MOD[3:0] bits are used to select the proper Capture mode, as shown in Table 16-3.

TABLE 16-3: INPUT CAPTURE MODES

MOD[3:0] (CCPxCON1L[3:0])	T32 (CCPxCON1L[5])	Operating Mode
0000	0	Edge Detect (16-bit capture)
0000	1	Edge Detect (32-bit capture)
0001	0	Every Rising (16-bit capture)
0001	1	Every Rising (32-bit capture)
0010	0	Every Falling (16-bit capture)
0010	1	Every Falling (32-bit capture)
0011	0	Every Rise/Fall (16-bit capture)
0011	1	Every Rise/Fall (32-bit capture)
0100	0	Every 4th Rising (16-bit capture)
0100	1	Every 4th Rising (32-bit capture)
0101	0	Every 16th Rising (16-bit capture)
0101	1	Every 16th Rising (32-bit capture)

FIGURE 16-6: INPUT CAPTURE x BLOCK DIAGRAM

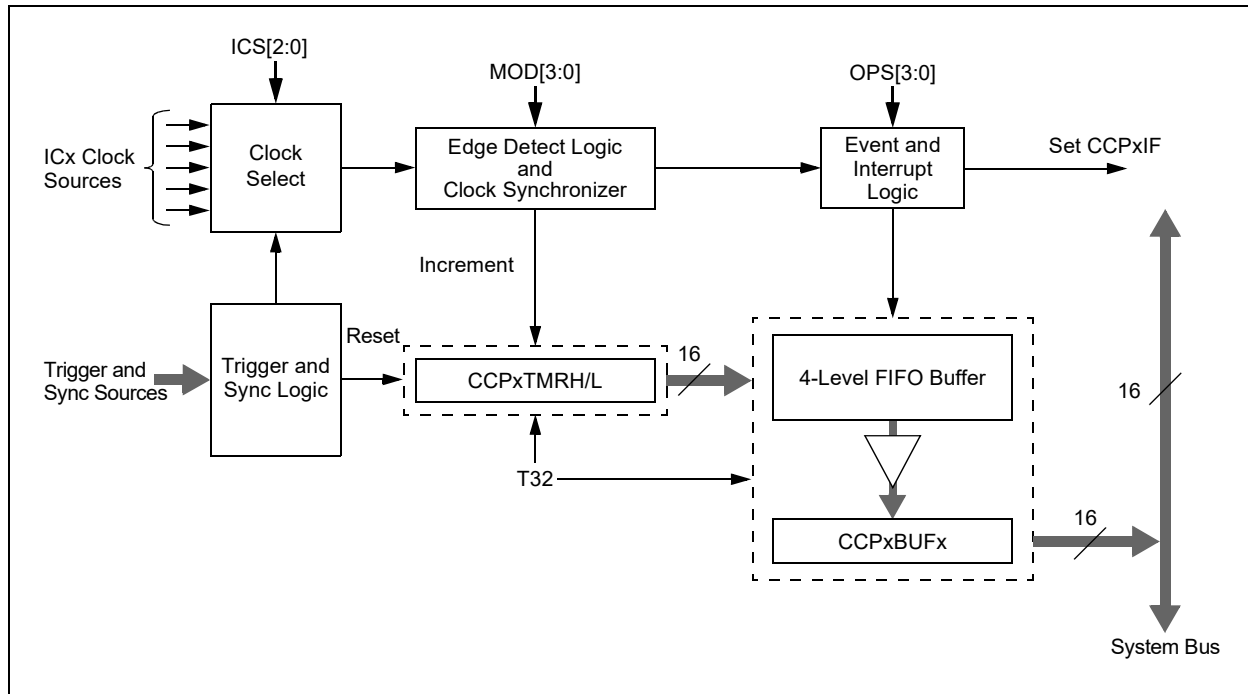

16.5 Auxiliary Output

The MCCPx modules have an auxiliary (secondary) output that provides other peripherals access to internal module signals. The auxiliary output is intended to connect to other MCCPx modules, or other digital peripherals, to provide these types of functions:

- Time Base Synchronization
- Peripheral Trigger and Clock Inputs
- Signal Gating

The type of output signal is selected using the AUXOUT[1:0] control bits (CCPxCON2H[4:3]). The type of output signal is also dependent on the module operating mode.

On the PIC24FJ256GA705 family of devices, only the CTMU discharge trigger has access to the auxiliary output signal.

TABLE 16-4: AUXILIARY OUTPUT

AUXOUT[1:0]	CCSEL	MOD[3:0]	Comments	Signal Description
00	x	xxxx	Auxiliary Output Disabled	No Output
01	0	0000	Time Base Modes	Time Base Period Reset or Rollover
10				Special Event Trigger Output
11				No Output
01	0	0001 through 1111	Output Compare Modes	Time Base Period Reset or Rollover
10				Output Compare Event Signal
11				Output Compare Signal
01	1	xxxxx	Input Capture Modes	Time Base Period Reset or Rollover
10				Reflects the Value of the ICDIS bit
11				Input Capture Event Signal

PIC24FJ256GA705 FAMILY

REGISTER 16-1: CCPxCON1L: CCPx CONTROL 1 LOW REGISTERS

R/W-0	U-0	R/W-0	R/W-0	R/W-0	R/W-0	R/W-0	R/W-0
CCPON	—	CCPSIDL	CCPSLP	TMRSYNC	CLKSEL2	CLKSEL1	CLKSEL0
bit 15						bit 8	

R/W-0	R/W-0	R/W-0	R/W-0	R/W-0	R/W-0	R/W-0	R/W-0
TMRPS1	TMRPS0	T32	CCSEL	MOD3	MOD2	MOD1	MOD0
bit 7						bit 0	

Legend:

R = Readable bit W = Writable bit U = Unimplemented bit, read as '0'
 -n = Value at POR '1' = Bit is set '0' = Bit is cleared x = Bit is unknown

- bit 15 **CCPON:** CCPx Module Enable bit
 1 = Module is enabled with an operating mode specified by the MOD[3:0] control bits
 0 = Module is disabled
- bit 14 **Unimplemented:** Read as '0'
- bit 13 **CCPSIDL:** CCPx Stop in Idle Mode Bit
 1 = Discontinues module operation when device enters Idle mode
 0 = Continues module operation in Idle mode
- bit 12 **CCPSLP:** CCPx Sleep Mode Enable bit
 1 = Module continues to operate in Sleep modes
 0 = Module does not operate in Sleep modes
- bit 11 **TMRSYNC:** Time Base Clock Synchronization bit
 1 = Module time base clock is synchronized to the internal system clocks; timing restrictions apply
 0 = Module time base clock is not synchronized to the internal system clocks
- bit 10-8 **CLKSEL[2:0]:** CCPx Time Base Clock Select bits
 111 = TCKIA pin
 110 = TCKIB pin
 101 = PLL clock
 100 = 2x peripheral clock
 010 = SOSC clock
 001 = Reference clock output
 000 = System clock
 For MCCP1:
 011 = CLC1 output
 For MCCP2:
 011 = CLC2 output
- bit 7-6 **TMRPS[1:0]:** Time Base Prescale Select bits
 11 = 1:64 Prescaler
 10 = 1:16 Prescaler
 01 = 1:4 Prescaler
 00 = 1:1 Prescaler
- bit 5 **T32:** 32-Bit Time Base Select bit
 1 = Uses 32-bit time base for timer, single edge output compare or input capture function
 0 = Uses 16-bit time base for timer, single edge output compare or input capture function
- bit 4 **CCSEL:** Capture/Compare Mode Select bit
 1 = Input capture peripheral
 0 = Output compare/PWM/timer peripheral (exact function is selected by the MOD[3:0] bits)

Note 1: Center-Aligned PWM mode is only available on MCCP modules. This feature is disabled on SCCP modules.

REGISTER 16-1: CCPxCON1L: CCPx CONTROL 1 LOW REGISTERS (CONTINUED)

bit 3-0 **MOD[3:0]:** CCPx Mode Select bits

For CCSEL = 1 (Input Capture modes):

- 1xxx = Reserved
- 011x = Reserved
- 0101 = Capture every 16th rising edge
- 0100 = Capture every 4th rising edge
- 0011 = Capture every rising and falling edge
- 0010 = Capture every falling edge
- 0001 = Capture every rising edge
- 0000 = Capture every rising and falling edge (Edge Detect mode)

For CCSEL = 0 (Output Compare/Timer modes):

- 1111 = External Input mode: Pulse generator is disabled, source is selected by ICS[2:0]
- 1110 = Reserved
- 110x = Reserved
- 10xx = Reserved
- 0111 = Variable Frequency Pulse mode
- 0110 = Center-Aligned Pulse Compare mode, buffered⁽¹⁾
- 0101 = Dual Edge Compare mode, buffered
- 0100 = Dual Edge Compare mode
- 0011 = 16-Bit/32-Bit Single Edge mode, toggles output on compare match
- 0010 = 16-Bit/32-Bit Single Edge mode, drives output low on compare match
- 0001 = 16-Bit/32-Bit Single Edge mode, drives output high on compare match
- 0000 = 16-Bit/32-Bit Timer mode, output functions are disabled

Note 1: Center-Aligned PWM mode is only available on MCCP modules. This feature is disabled on SCCP modules.

PIC24FJ256GA705 FAMILY

REGISTER 16-2: CCPxCON1H: CCPx CONTROL 1 HIGH REGISTERS

R/W-0	R/W-0	U-0	U-0	R/W-0	R/W-0	R/W-0	R/W-0
OPSSRC ⁽¹⁾	RTRGEN ⁽²⁾	—	—	OPS3 ⁽³⁾	OPS2 ⁽³⁾	OPS1 ⁽³⁾	OPS0 ⁽³⁾
bit 15							bit 8

R/W-0	R/W-0	R/W-0	R/W-0	R/W-0	R/W-0	R/W-0	R/W-0
TRIGEN	ONESHOT	ALTSYNC	SYNC4	SYNC3	SYNC2	SYNC1	SYNC0
bit 7							bit 0

Legend:

R = Readable bit W = Writable bit U = Unimplemented bit, read as '0'
 -n = Value at POR '1' = Bit is set '0' = Bit is cleared x = Bit is unknown

- bit 15 **OPSSRC:** Output Postscaler Source Select bit⁽¹⁾
 1 = Output postscaler scales module trigger output events
 0 = Output postscaler scales time base interrupt events
- bit 14 **RTRGEN:** Retrigger Enable bit⁽²⁾
 1 = Time base can be retriggered when the TRIGEN bit = 1
 0 = Time base may not be retriggered when the TRIGEN bit = 1
- bit 13-12 **Unimplemented:** Read as '0'
- bit 11-8 **OPS3[3:0]:** CCPx Interrupt Output Postscale Select bits⁽³⁾
 1111 = Interrupt every 16th time base period match
 1110 = Interrupt every 15th time base period match
 ...
 0100 = Interrupt every 5th time base period match
 0011 = Interrupt every 4th time base period match or 4th input capture event
 0010 = Interrupt every 3rd time base period match or 3rd input capture event
 0001 = Interrupt every 2nd time base period match or 2nd input capture event
 0000 = Interrupt after each time base period match or input capture event
- bit 7 **TRIGEN:** CCPx Trigger Enable bit
 1 = Trigger operation of time base is enabled
 0 = Trigger operation of time base is disabled
- bit 6 **ONESHOT:** One-Shot Mode Enable bit
 1 = One-Shot Trigger mode is enabled; Trigger mode duration is set by OSCNT[2:0]
 0 = One-Shot Trigger mode is disabled
- bit 5 **ALTSYNC:** CCPx Clock Select bit
 1 = An alternate signal is used as the module synchronization output signal
 0 = The module synchronization output signal is the Time Base Reset/rollover event
- bit 4-0 **SYNC[4:0]:** CCPx Synchronization Source Select bits
 See [Table 16-5](#) for the definition of inputs.

- Note 1:** This control bit has no function in Input Capture modes.
Note 2: This control bit has no function when TRIGEN = 0.
Note 3: Output postscale settings, from 1:5 to 1:16 (0100-1111), will result in a FIFO buffer overflow for Input Capture modes.

TABLE 16-5: SYNCHRONIZATION SOURCES

SYNC[4:0]	Synchronization Source
11111	None; Timer with Rollover on CCPxPR Match or FFFFh
11110	Reserved
11101	Reserved
11100	CTMU Trigger
11011	A/D Start Conversion
11010	CMP3 Trigger
11001	CMP2 Trigger
11000	CMP1 Trigger
10111	Reserved
10110	Reserved
10101	Reserved
10100	Reserved
10011	Reserved
10010	Reserved
10001	CLC2 Out
10000	CLC1 Out
01111	Reserved
01110	Reserved
01101	Reserved
01100	Reserved
01011	INT2 Pad
01010	INT1 Pad
01001	INT0 Pad
01000	Reserved
00111	Reserved
00110	Reserved
00101	MCCP4 Sync Out
00100	MCCP3 Sync Out
00011	MCCP2 Sync Out
00010	MCCP1 Sync Out
00001	MCCPx Sync Out ⁽¹⁾
00000	MCCPx Timer Sync Out ⁽¹⁾

Note 1: CCP1 when connected to CCP1, CCP2 when connected to CCP2, etc.

PIC24FJ256GA705 FAMILY

REGISTER 16-3: CCPxCON2L: CCPx CONTROL 2 LOW REGISTERS

R/W-0	R/W-0	U-0	R/W-0	U-0	U-0	U-0	U-0
PWMRSEN	ASDGM	—	SSDG	—	—	—	—
bit 15						bit 8	

R/W-0	R/W-0	R/W-0	R/W-0	R/W-0	R/W-0	R/W-0	R/W-0
ASDG[7:0]							
bit 7						bit 0	

Legend:

R = Readable bit W = Writable bit U = Unimplemented bit, read as '0'
 -n = Value at POR '1' = Bit is set '0' = Bit is cleared x = Bit is unknown

- bit 15 **PWMRSEN:** CCPx PWM Restart Enable bit
 1 = ASEVT bit clears automatically at the beginning of the next PWM period, after the shutdown input has ended
 0 = ASEVT bit must be cleared in software to resume PWM activity on output pins
- bit 14 **ASDGM:** CCPx Auto-Shutdown Gate Mode Enable bit
 1 = Waits until the next Time Base Reset or rollover for shutdown to occur
 0 = Shutdown event occurs immediately
- bit 13 **Unimplemented:** Read as '0'
- bit 12 **SSDG:** CCPx Software Shutdown/Gate Control bit
 1 = Manually forces auto-shutdown, timer clock gate or input capture signal gate event (setting of ASDGM bit still applies)
 0 = Normal module operation
- bit 11-8 **Unimplemented:** Read as '0'
- bit 7-0 **ASDG[7:0]:** CCPx Auto-Shutdown/Gating Source Enable bits
 1 = ASDGx Source n is enabled (see [Table 16-6](#) for auto-shutdown/gating sources)
 0 = ASDGx Source n is disabled

TABLE 16-6: AUTO-SHUTDOWN SOURCES

ASDG[7:0]	Auto-Shutdown Source			
	MCCP1	MCCP2	MCCP3	MCCP4
1xxx xxxx	OCFB			
x1xx xxxx	OCFA			
xx1x xxxx	CLC1	CLC2	Not Used	
xxx1 xxxx	Not Used			
xxxx 1xxx	Not Used			
xxxx x1xx	CMP3 Out			
xxxx xx1x	CMP2 Out			
xxxx xxx1	CMP1 Out			

REGISTER 16-4: CCPxCON2H: CCPx CONTROL 2 HIGH REGISTERS

R/W-0	U-0	R/W-0	R/W-0	R/W-0	R/W-0	R/W-0	R/W-1
OENSYNC	—	OCFEN ^(1,2)	OCEEN ^(1,2)	OCDEN ^(1,2)	OCCEN ^(1,2)	OCBEN ^(1,2)	OCAEN ⁽²⁾
bit 15							bit 8

R/W-0	R/W-0	U-0	R/W-0	R/W-0	R/W-0	R/W-0	R/W-0
ICGSM1	ICGSM0	—	AUXOUT1	AUXOUT0	ICS2	ICS1	ICS0
bit 7							bit 0

Legend:

R = Readable bit W = Writable bit U = Unimplemented bit, read as '0'
 -n = Value at POR '1' = Bit is set '0' = Bit is cleared x = Bit is unknown

- bit 15 **OENSYNC:** Output Enable Synchronization bit
 1 = Update by output enable bits occurs on the next Time Base Reset or rollover
 0 = Update by output enable bits occurs immediately
- bit 14 **Unimplemented:** Read as '0'
- bit 13-8 **OCxEN:** Output Enable/Steering Control bits^(1,2)
 1 = OCMx pin is controlled by the CCPx module and produces an output compare or PWM signal
 0 = OCMx pin is not controlled by the CCPx module; the pin is available to the port logic or another peripheral multiplexed on the pin
- bit 7-6 **ICGSM[1:0]:** Input Capture Gating Source Mode Control bits
 11 = Reserved
 10 = One-Shot mode: Falling edge from gating source disables future capture events (ICDIS = 1)
 01 = One-Shot mode: Rising edge from gating source enables future capture events (ICDIS = 0)
 00 = Level-Sensitive mode: A high level from gating source will enable future capture events; a low level will disable future capture events
- bit 5 **Unimplemented:** Read as '0'
- bit 4-3 **AUXOUT[1:0]:** Auxiliary Output Signal on Event Selection bits
 11 = Input capture or output compare event; no signal in Timer mode
 10 = Signal output is defined by module operating mode (see [Table 16-4](#))
 01 = Time base rollover event (all modes)
 00 = Disabled
- bit 2-0 **ICS[2:0]:** Input Capture Source Select bits
 111 = Reserved
 110 = Reserved
 101 = CLC2 output
 100 = CLC1 output
 011 = Comparator 3 output
 010 = Comparator 2 output
 001 = Comparator 1 output
 000 = Input Capture x (ICMx) I/O pin

- Note 1:** OCFEN through OCBEN (bits[13:9]) are not implemented in all CCPx modules.
Note 2: OCFEN through OCAEN (bits[13:8]) are not dedicated pins in all CCPx modules, PPS has to be used.

PIC24FJ256GA705 FAMILY

REGISTER 16-5: CCPxCON3L: CCPx CONTROL 3 LOW REGISTERS⁽¹⁾

U-0	U-0	U-0	U-0	U-0	U-0	U-0	U-0
—	—	—	—	—	—	—	—
bit 15							bit 8

U-0	U-0	R/W-0	R/W-0	R/W-0	R/W-0	R/W-0	R/W-0
—	—	DT[5:0]					
bit 7						bit 0	

Legend:

R = Readable bit	W = Writable bit	U = Unimplemented bit, read as '0'
-n = Value at POR	'1' = Bit is set	'0' = Bit is cleared x = Bit is unknown

bit 15-6 **Unimplemented:** Read as '0'
bit 5-0 **DT[5:0]:** CCPx Dead-Time Select bits⁽¹⁾

- 111111 = Inserts 63 dead-time delay periods between complementary output signals
- 111110 = Inserts 62 dead-time delay periods between complementary output signals
- ...
- 000010 = Inserts 2 dead-time delay periods between complementary output signals
- 000001 = Inserts 1 dead-time delay period between complementary output signals
- 000000 = Dead-time logic is disabled

Note 1: This register is implemented in the MCCP1 module only.

PIC24FJ256GA705 FAMILY

REGISTER 16-6: CCPxCON3H: CCPx CONTROL 3 HIGH REGISTERS

R/W-0	R/W-0	R/W-0	R/W-0	U-0	R/W-0	R/W-0	R/W-0
OETRIG	OSCNT2	OSCNT1	OSCNT0	—	OUTM2 ⁽¹⁾	OUTM1 ⁽¹⁾	OUTM0 ⁽¹⁾
bit 15							bit 8

U-0	U-0	R/W-0	R/W-0	R/W-0	R/W-0	R/W-0	R/W-0
—	—	POLACE	POLBDF ⁽¹⁾	PSSACE1	PSSACE0	PSSBDF1 ⁽¹⁾	PSSBDF0 ⁽¹⁾
bit 7							bit 0

Legend:

R = Readable bit	W = Writable bit	U = Unimplemented bit, read as '0'
-n = Value at POR	'1' = Bit is set	'0' = Bit is cleared
		x = Bit is unknown

- bit 15 **OETRIG:** CCPx Dead-Time Select bit
 1 = For Triggered mode (TRIGEN = 1): Module does not drive enabled output pins until triggered
 0 = Normal output pin operation
- bit 14-12 **OSCNT[2:0]:** One-Shot Event Count bits
 111 = Extends one-shot event by seven time base periods (eight time base periods total)
 110 = Extends one-shot event by six time base periods (seven time base periods total)
 101 = Extends one-shot event by five time base periods (six time base periods total)
 100 = Extends one-shot event by four time base periods (five time base periods total)
 011 = Extends one-shot event by three time base periods (four time base periods total)
 010 = Extends one-shot event by two time base periods (three time base periods total)
 001 = Extends one-shot event by one time base period (two time base periods total)
 000 = Does not extend one-shot trigger event
- bit 11 **Unimplemented:** Read as '0'
- bit 10-8 **OUTM[2:0]:** PWMx Output Mode Control bits⁽¹⁾
 111 = Reserved
 110 = Output Scan mode
 101 = Brush DC Output mode, forward
 100 = Brush DC Output mode, reverse
 011 = Reserved
 010 = Half-Bridge Output mode
 001 = Push-Pull Output mode
 000 = Steerable Single Output mode
- bit 7-6 **Unimplemented:** Read as '0'
- bit 5 **POLACE:** CCPx Output Pins, OCMxA, OCMxC and OCMxE, Polarity Control bit
 1 = Output pin polarity is active-low
 0 = Output pin polarity is active-high
- bit 4 **POLBDF:** CCPx Output Pins, OCMxB, OCMxD and OCMxF, Polarity Control bit⁽¹⁾
 1 = Output pin polarity is active-low
 0 = Output pin polarity is active-high
- bit 3-2 **PSSACE[1:0]:** PWMx Output Pins, OCMxA, OCMxC and OCMxE, Shutdown State Control bits
 11 = Pins are driven active when a shutdown event occurs
 10 = Pins are driven inactive when a shutdown event occurs
 0x = Pins are tri-stated when a shutdown event occurs
- bit 1-0 **PSSBDF[1:0]:** PWMx Output Pins, OCMxB, OCMxD, and OCMxF, Shutdown State Control bits⁽¹⁾
 11 = Pins are driven active when a shutdown event occurs
 10 = Pins are driven inactive when a shutdown event occurs
 0x = Pins are in a High-Impedance state when a shutdown event occurs

Note 1: These bits are implemented in the MCCP1 module only.

PIC24FJ256GA705 FAMILY

REGISTER 16-7: CCPxSTATL: CCPx STATUS REGISTER LOW

U-0	U-0	U-0	U-0	U-0	W-0	U-0	U-0
—	—	—	—	—	ICGARM	—	—
bit 15					bit 8		

R-0	W1-0	W1-0	R/C-0	R/C-0	R/C-0	R/C-0	R/C-0
CCPTRIG	TRSET	TRCLR	ASEVT	SCEVT	ICDIS	ICOV	ICBNE
bit 7						bit 0	

Legend:	C = Clearable bit	W = Writable bit
R = Readable bit	W1 = Write '1' Only bit	U = Unimplemented bit, read as '0'
-n = Value at POR	'1' = Bit is set	'0' = Bit is cleared x = Bit is unknown

- bit 15-11 **Unimplemented:** Read as '0'
- bit 10 **ICGARM:** Input Capture Gate Arm bit
A write of '1' to this location will arm the Input Capture x module for a one-shot gating event when ICGSM[1:0] = 01 or 10; read as '0'.
- bit 9-8 **Unimplemented:** Read as '0'
- bit 7 **CCPTRIG:** CCPx Trigger Status bit
1 = Timer has been triggered and is running
0 = Timer has not been triggered and is held in Reset
- bit 6 **TRSET:** CCPx Trigger Set Request bit
Writes '1' to this location to trigger the timer when TRIGEN = 1 (location always reads as '0').
- bit 5 **TRCLR:** CCPx Trigger Clear Request bit
Writes '1' to this location to cancel the timer trigger when TRIGEN = 1 (location always reads as '0').
- bit 4 **ASEVT:** CCPx Auto-Shutdown Event Status/Control bit
1 = A shutdown event is in progress; CCPx outputs are in the Shutdown state
0 = CCPx outputs operate normally
- bit 3 **SCEVT:** Single Edge Compare Event Status bit
1 = A single edge compare event has occurred
0 = A single edge compare event has not occurred
- bit 2 **ICDIS:** Input Capture x Disable bit
1 = Event on Input Capture x pin (ICMx) does not generate a capture event
0 = Event on Input Capture x pin will generate a capture event
- bit 1 **ICOV:** Input Capture x Buffer Overflow Status bit
1 = The Input Capture x FIFO buffer has overflowed
0 = The Input Capture x FIFO buffer has not overflowed
- bit 0 **ICBNE:** Input Capture x Buffer Status bit
1 = Input Capture x buffer has data available
0 = Input Capture x buffer is empty

17.0 SERIAL PERIPHERAL INTERFACE (SPI)

Note: This data sheet summarizes the features of the PIC24FJ256GA705 family of devices. It is not intended to be a comprehensive reference source. To complement the information in this data sheet, refer to “**Serial Peripheral Interface (SPI) with Audio Codec Support**” (www.microchip.com/DS70005136) in the “*dsPIC33/PIC24 Family Reference Manual*”. The information in this data sheet supersedes the information in the FRM.

The Serial Peripheral Interface (SPI) module is a synchronous serial interface useful for communicating with other peripheral or microcontroller devices. These peripheral devices may be serial EEPROMs, shift registers, display drivers, A/D Converters, etc. The SPI module is compatible with the Motorola® SPI and SIOP interfaces. All devices in the PIC24FJ256GA705 family include three SPI modules.

The module supports operation in two buffer modes. In Standard Buffer mode, data are shifted through a single serial buffer. In Enhanced Buffer mode, data are shifted through a FIFO buffer. The FIFO level depends on the configured mode.

Variable length data can be transmitted and received from 2 to 32 bits.

Note: Do not perform Read-Modify-Write operations (such as bit-oriented instructions) on the SPIxBUF register in either Standard or Enhanced Buffer mode.

The module also supports a basic framed SPI protocol while operating in either Master or Slave mode. A total of four framed SPI configurations are supported.

The module also supports Audio modes. Four different Audio modes are available.

- I²S mode
- Left Justified mode
- Right Justified mode
- PCM/DSP mode

In each of these modes, the serial clock is free-running and audio data are always transferred.

If an audio protocol data transfer takes place between two devices, then usually one device is the Master and the other is the Slave. However, audio data can be transferred between two Slaves. Because the audio protocols require free-running clocks, the Master can be a third party controller. In either case, the Master generates two free-running clocks: SCKx and LRC (Left, Right Channel Clock/SSx/FSYNC).

The SPI serial interface consists of four pins:

- SDIx: Serial Data Input
- SDOx: Serial Data Output
- SCKx: Shift Clock Input or Output
- SSx: Active-Low Slave Select or Frame Synchronization I/O Pulse

The SPI module can be configured to operate using two, three or four pins. In 3-pin mode, SSx is not used. In 2-pin mode, both SDOx and SSx are not used.

The SPI module has the ability to generate three interrupts reflecting the events that occur during the data communication. The following types of interrupts can be generated:

1. Receive interrupts are signalled by SPIxRXIF. This event occurs when:
 - RX watermark interrupt
 - SPIROV = 1
 - SPIRBF = 1
 - SPIRBE = 1

provided the respective mask bits are enabled in SPIxIMSKL/H.
2. Transmit interrupts are signalled by SPIxTXIF. This event occurs when:
 - TX watermark interrupt
 - SPITUR = 1
 - SPITBF = 1
 - SPITBE = 1

provided the respective mask bits are enabled in SPIxIMSKL/H.
3. General interrupts are signalled by SPIxIF. This event occurs when
 - FRMERR = 1
 - SPIBUSY = 1
 - SRMT = 1

provided the respective mask bits are enabled in SPIxIMSKL/H.

A block diagram of the module in Enhanced Buffer mode is shown in [Figure 17-1](#).

Note: In this section, the SPI modules are referred to together as SPIx, or separately as SPI1, SPI2 or SPI3. Special Function Registers will follow a similar notation. For example, SPIxCON1 and SPIxCON2 refer to the control registers for any of the three SPI modules.

PIC24FJ256GA705 FAMILY

17.1 Master Mode Operation

Perform the following steps to set up the SPIx module for Master mode operation:

1. Disable the SPIx interrupts in the respective IECx register.
2. Stop and reset the SPIx module by clearing the SPIEN bit.
3. Clear the receive buffer.
4. Clear the ENHBUF bit (SPIxCON1L[0]) if using Standard Buffer mode or set the bit if using Enhanced Buffer mode.
5. If SPIx interrupts are not going to be used, skip this step. Otherwise, the following additional steps are performed:
 - a) Clear the SPIx interrupt flags/events in the respective IFSx register.
 - b) Write the SPIx interrupt priority and sub-priority bits in the respective IPCx register.
 - c) Set the SPIx interrupt enable bits in the respective IECx register.
6. Write the Baud Rate register, SPIxBRGL.
7. Clear the SPIROV bit (SPIxSTATL[6]).
8. Write the desired settings to the SPIxCON1L register with MSTEN (SPIxCON1L[5]) = 1.
9. Enable SPI operation by setting the SPIEN bit (SPIxCON1L[15]).
10. Write the data to be transmitted to the SPIxBUFL and SPIxBUFH registers. Transmission (and reception) will start as soon as data are written to the SPIxBUFL/H registers.

17.2 Slave Mode Operation

The following steps are used to set up the SPIx module for the Slave mode of operation:

1. If using interrupts, disable the SPIx interrupts in the respective IECx register.
2. Stop and reset the SPIx module by clearing the SPIEN bit.
3. Clear the receive buffer.
4. Clear the ENHBUF bit (SPIxCON1L[0]) if using Standard Buffer mode or set the bit if using Enhanced Buffer mode.
5. If using interrupts, the following additional steps are performed:
 - a) Clear the SPIx interrupt flags/events in the respective IFSx register.
 - b) Write the SPIx interrupt priority and sub-priority bits in the respective IPCx register.
 - c) Set the SPIx interrupt enable bits in the respective IECx register.

6. Clear the SPIROV bit (SPIxSTATL[6]).
7. Write the desired settings to the SPIxCON1L register with MSTEN (SPIxCON1L[5]) = 0.
8. Enable SPI operation by setting the SPIEN bit (SPIxCON1L[15]).
9. Transmission (and reception) will start as soon as the Master provides the serial clock.

The following additional features are provided in Slave mode:

- **Slave Select Synchronization:**
The \overline{SSx} pin allows a Synchronous Slave mode. If the SSEN bit (SPIxCON1L[7]) is set, transmission and reception are enabled in Slave mode only if the \overline{SSx} pin is driven to a Low state. The port output or other peripheral outputs must not be driven in order to allow the \overline{SSx} pin to function as an input. If the SSEN bit is set and the \overline{SSx} pin is driven high, the SDOx pin is no longer driven and will tri-state, even if the module is in the middle of a transmission. An aborted transmission will be tried again the next time the \overline{SSx} pin is driven low using the data held in the SPIxTXB register. If the SSEN bit is not set, the \overline{SSx} pin does not affect the module operation in Slave mode.
- **SPITBE Status Flag Operation:**
The SPITBE bit (SPIxSTATL[3]) has a different function in the Slave mode of operation. The following describes the function of SPITBE for various settings of the Slave mode of operation:
 - If SSEN (SPIxCON1L[7]) is cleared, the SPITBE bit is cleared when SPIxBUF is loaded by the user code. It is set when the module transfers SPIxTXB to SPIxTXSR. This is similar to the SPITBE bit function in Master mode.
 - If SSEN is set, SPITBE is cleared when SPIxBUF is loaded by the user code. However, it is set only when the SPIx module completes data transmission. A transmission will be aborted when the \overline{SSx} pin goes high and may be retried at a later time. So, each data word is held in SPIxTXB until all bits are transmitted to the receiver.

FIGURE 17-1: SPIx MODULE BLOCK DIAGRAM (ENHANCED MODE)

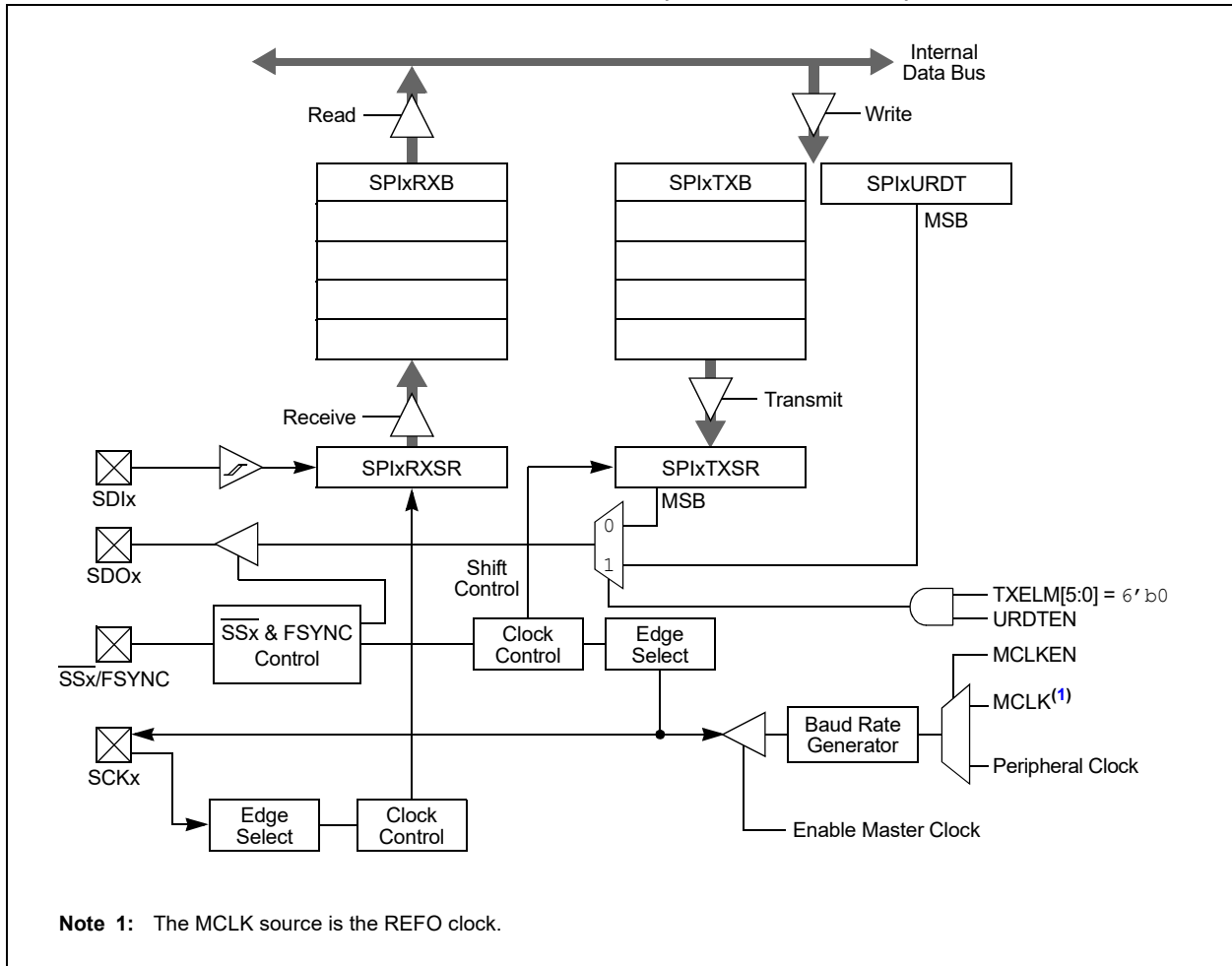

17.3 Audio Mode Operation

To initialize the SPIx module for Audio mode, follow the steps to initialize it for Master/Slave mode, but also set the AUDEN bit (SPIxCON1H[15]). In Master+Audio mode:

- This mode enables the device to generate SCKx and LRC pulses as long as the SPIEN bit (SPIxCON1L[15]) = 1.
- The SPIx module generates LRC and SCKx continuously in all cases, regardless of the transmit data, while in Master mode.
- The SPIx module drives the leading edge of LRC and SCKx within one SCKx period, and the serial data shift in and out continuously, even when the TX FIFO is empty.

In Slave+Audio mode:

- This mode enables the device to receive SCKx and LRC pulses as long as the SPIEN bit (SPIxCON1L[15]) = 1.
- The SPIx module drives zeros out of SDOx, but does not shift data out or in (SDIx) until the module receives the LRC (i.e., the edge that precedes the left channel).
- Once the module receives the leading edge of LRC, it starts receiving data if DISSDI (SPIxCON1L[4]) = 0 and the serial data shift out continuously, even when the TX FIFO is empty.

PIC24FJ256GA705 FAMILY

17.4 SPI Control Registers

REGISTER 17-1: SPIxCON1L: SPIx CONTROL REGISTER 1 LOW

R/W-0	U-0	R/W-0	R/W-0	R/W-0	R/W-0	R/W-0	R/W-0
SPIEN	—	SPISIDL	DISSDO	MODE32 ^(1,4)	MODE16 ^(1,4)	SMP	CKE ⁽¹⁾
bit 15							bit 8

R/W-0	R/W-0	R/W-0	R/W-0	R/W-0	R/W-0	R/W-0	R/W-0
SSEN ⁽²⁾	CKP	MSTEN	DISSDI	DISSCK	MCLKEN ⁽³⁾	SPIFE	ENHBUF
bit 7							bit 0

Legend:

R = Readable bit W = Writable bit U = Unimplemented bit, read as '0'
 -n = Value at POR '1' = Bit is set '0' = Bit is cleared x = Bit is unknown

- bit 15 **SPIEN:** SPIx On bit
 1 = Enables module
 0 = Turns off and resets module, disables clocks, disables interrupt event generation, allows SFR modifications
- bit 14 **Unimplemented:** Read as '0'
- bit 13 **SPISIDL:** SPIx Stop in Idle Mode bit
 1 = Halts in CPU Idle mode
 0 = Continues to operate in CPU Idle mode
- bit 12 **DISSDO:** Disable SDOx Output Port bit
 1 = SDOx pin is not used by the module; pin is controlled by the port function
 0 = SDOx pin is controlled by the module
- bit 11-10 **MODE[32,16]:** Serial Word Length bits^(1,4)
 AUDEN = 0:
 MODE32 MODE16 COMMUNICATION FIFO DEPTH
 1 x 32-Bit 8
 0 1 16-Bit 16
 0 0 8-Bit 32
 AUDEN = 1:
 MODE32 MODE16 COMMUNICATION
 1 1 24-Bit Data, 32-Bit FIFO, 32-Bit Channel/64-Bit Frame
 1 0 32-Bit Data, 32-Bit FIFO, 32-Bit Channel/64-Bit Frame
 0 1 16-Bit Data, 16-Bit FIFO, 32-Bit Channel/64-Bit Frame
 0 0 16-Bit Data, 16-Bit FIFO, 16-Bit Channel/32-Bit Frame
- bit 9 **SMP:** SPIx Data Input Sample Phase bit
 Master Mode:
 1 = Input data are sampled at the end of data output time
 0 = Input data are sampled at the middle of data output time
 Slave Mode:
 Input data are always sampled at the middle of data output time, regardless of the SMP setting.

- Note 1:** When AUDEN = 1, this module functions as if CKE = 0, regardless of its actual value.
Note 2: When FRMEN = 1, SSEN is not used.
Note 3: MCLKEN can only be written when the SPIEN bit = 0.
Note 4: This channel is not meaningful for DSP/PCM mode as LRC follows the FRMSYPW bit.
Note 5: The MCLK source is the REFO clock.

REGISTER 17-1: SPIxCON1L: SPIx CONTROL REGISTER 1 LOW (CONTINUED)

bit 8	CKE: SPIx Clock Edge Select bit ⁽¹⁾ 1 = Transmit happens on transition from Active Clock state to Idle Clock state 0 = Transmit happens on transition from Idle Clock state to Active Clock state
bit 7	SSEN: Slave Select Enable bit (Slave mode) ⁽²⁾ 1 = \overline{SSx} pin is used by the macro in Slave mode; \overline{SSx} pin is used as the Slave select input 0 = \overline{SSx} pin is not used by the macro (\overline{SSx} pin will be controlled by the port I/O)
bit 6	CKP: SPIx Clock Polarity Select bit 1 = Idle state for clock is a high level; active state is a low level 0 = Idle state for clock is a low level; active state is a high level
bit 5	MSTEN: Master Mode Enable bit 1 = Master mode 0 = Slave mode
bit 4	DISSDI: Disable SDIx Input Port bit 1 = SDIx pin is not used by the module; pin is controlled by the port function 0 = SDIx pin is controlled by the module
bit 3	DISSCK: Disable SCKx Output Port bit 1 = SCKx pin is not used by the module; pin is controlled by the port function 0 = SCKx pin is controlled by the module
bit 2	MCLKEN: Master Clock Enable bit ⁽³⁾ 1 = MCLK is used by the BRG ⁽⁵⁾ 0 = Peripheral Clock is used by the BRG
bit 1	SPIFE: Frame Sync Pulse Edge Select bit 1 = Frame Sync pulse (Idle-to-active edge) coincides with the first bit clock 0 = Frame Sync pulse (Idle-to-active edge) precedes the first bit clock
bit 0	ENHBUF: Enhanced Buffer Mode Enable bit 1 = Enhanced Buffer mode is enabled 0 = Enhanced Buffer mode is disabled

- Note 1:** When AUDEN = 1, this module functions as if CKE = 0, regardless of its actual value.
2: When FRMEN = 1, SSEN is not used.
3: MCLKEN can only be written when the SPIEN bit = 0.
4: This channel is not meaningful for DSP/PCM mode as LRC follows the FRMSYPW bit.
5: The MCLK source is the REFO clock.

PIC24FJ256GA705 FAMILY

REGISTER 17-2: SPIxCON1H: SPIx CONTROL REGISTER 1 HIGH

R/W-0	R/W-0	R/W-0	R/W-0	R/W-0	R/W-0	R/W-0	R/W-0
AUDEN ⁽¹⁾	SPIGNEXT	IGNROV	IGNTUR	AUDMONO ⁽²⁾	URDTEN ⁽³⁾	AUDMOD1 ⁽⁴⁾	AUDMOD0 ⁽⁴⁾
bit 15						bit 8	

R/W-0	R/W-0	R/W-0	R/W-0	R/W-0	R/W-0	R/W-0	R/W-0
FRMEN	FRMSYNC	FRMPOL	MSEN	FRMSYPW	FRMCNT2	FRMCNT1	FRMCNT0
bit 7						bit 0	

Legend:

R = Readable bit	W = Writable bit	U = Unimplemented bit, read as '0'
-n = Value at POR	'1' = Bit is set	'0' = Bit is cleared
		x = Bit is unknown

- bit 15 **AUDEN:** Audio Codec Support Enable bit⁽¹⁾
 1 = Audio protocol is enabled; MSTEN controls the direction of both the SCKx and frame (a.k.a. LRC), and this module functions as if FRMEN = 1, FRMSYNC = MSTEN, FRMCNT[2:0] = 001 and SMP = 0, regardless of their actual values
 0 = Audio protocol is disabled
- bit 14 **SPIGNEXT:** SPIx Sign-Extend RX FIFO Read Data Enable bit
 1 = Data from RX FIFO are sign-extended
 0 = Data from RX FIFO are not sign-extended
- bit 13 **IGNROV:** Ignore Receive Overflow bit
 1 = A Receive Overflow (ROV) is NOT a critical error; during ROV, data in the FIFO are not overwritten by the receive data
 0 = A ROV is a critical error that stops SPI operation
- bit 12 **IGNTUR:** Ignore Transmit Underrun bit
 1 = A Transmit Underrun (TUR) is NOT a critical error and data indicated by URDTEN are transmitted until the SPIxTXB is not empty
 0 = A TUR is a critical error that stops SPI operation
- bit 11 **AUDMONO:** Audio Data Format Transmit bit⁽²⁾
 1 = Audio data are mono (i.e., each data word is transmitted on both left and right channels)
 0 = Audio data are stereo
- bit 10 **URDTEN:** Transmit Underrun Data Enable bit⁽³⁾
 1 = Transmits data out of SPIxURDTL/H register during Transmit Underrun conditions
 0 = Transmits the last received data during Transmit Underrun conditions
- bit 9-8 **AUDMOD[1:0]:** Audio Protocol Mode Selection bits⁽⁴⁾
 11 = PCM/DSP mode
 10 = Right Justified mode: This module functions as if SPIFE = 1, regardless of its actual value
 01 = Left Justified mode: This module functions as if SPIFE = 1, regardless of its actual value
 00 = I²S mode: This module functions as if SPIFE = 0, regardless of its actual value
- bit 7 **FRMEN:** Framed SPIx Support bit
 1 = Framed SPIx support is enabled (\overline{SSx} pin is used as the FSYNC input/output)
 0 = Framed SPIx support is disabled

- Note 1:** AUDEN can only be written when the SPIEN bit = 0.
Note 2: AUDMONO can only be written when the SPIEN bit = 0 and is only valid for AUDEN = 1.
Note 3: URDTEN is only valid when IGNTUR = 1.
Note 4: AUDMOD[1:0] bits can only be written when the SPIEN bit = 0 and are only valid when AUDEN = 1. When NOT in PCM/DSP mode, this module functions as if FRMSYPW = 1, regardless of its actual value.

REGISTER 17-2: SPIxCON1H: SPIx CONTROL REGISTER 1 HIGH (CONTINUED)

- bit 6 **FRMSYNC:** Frame Sync Pulse Direction Control bit
1 = Frame Sync pulse input (Slave)
0 = Frame Sync pulse output (Master)
- bit 5 **FRMPOL:** Frame Sync/Slave Select Polarity bit
1 = Frame Sync pulse/Slave select is active-high
0 = Frame Sync pulse/Slave select is active-low
- bit 4 **MSEN:** Master Mode Slave Select Enable bit
1 = SPIx Slave select support is enabled with polarity determined by FRMPOL (\overline{SSx} pin is automatically driven during transmission in Master mode)
0 = SPIx Slave select support is disabled (\overline{SSx} pin will be controlled by port IO)
- bit 3 **FRMSYPW:** Frame Sync Pulse-Width bit
1 = Frame Sync pulse is one serial word length wide (as defined by MODE[32,16]/WLENGTH[4:0])
0 = Frame Sync pulse is one clock (SCK) wide
- bit 2-0 **FRMCNT[2:0]:** Frame Sync Pulse Counter bits
Controls the number of serial words transmitted per Sync pulse.
111 = Reserved
110 = Reserved
101 = Generates a Frame Sync pulse on every 32 serial words
100 = Generates a Frame Sync pulse on every 16 serial words
011 = Generates a Frame Sync pulse on every 8 serial words
010 = Generates a Frame Sync pulse on every 4 serial words
001 = Generates a Frame Sync pulse on every 2 serial words (value used by audio protocols)
000 = Generates a Frame Sync pulse on each serial word

- Note 1:** AUDEN can only be written when the SPIEN bit = 0.
2: AUDMONO can only be written when the SPIEN bit = 0 and is only valid for AUDEN = 1.
3: URDTEN is only valid when IGNTUR = 1.
4: AUDMOD[1:0] bits can only be written when the SPIEN bit = 0 and are only valid when AUDEN = 1. When NOT in PCM/DSP mode, this module functions as if FRMSYPW = 1, regardless of its actual value.

PIC24FJ256GA705 FAMILY

REGISTER 17-3: SPIxCON2L: SPIx CONTROL REGISTER 2 LOW

U-0	U-0	U-0	U-0	U-0	U-0	U-0	U-0
—	—	—	—	—	—	—	—
bit 15							bit 8

U-0	U-0	U-0	R/W-0	R/W-0	R/W-0	R/W-0	R/W-0
—	—	—	WLENGTH[4:0] ^(1,2)				—
bit 7						bit 0	

Legend:

R = Readable bit W = Writable bit U = Unimplemented bit, read as '0'
 -n = Value at POR '1' = Bit is set '0' = Bit is cleared x = Bit is unknown

- bit 15-5 **Unimplemented:** Read as '0'
- bit 4-0 **WLENGTH[4:0]:** Variable Word Length bits^(1,2)
- 11111 = 32-bit data
 - 11110 = 31-bit data
 - 11101 = 30-bit data
 - 11100 = 29-bit data
 - 11011 = 28-bit data
 - 11010 = 27-bit data
 - 11001 = 26-bit data
 - 11000 = 25-bit data
 - 10111 = 24-bit data
 - 10110 = 23-bit data
 - 10101 = 22-bit data
 - 10100 = 21-bit data
 - 10011 = 20-bit data
 - 10010 = 19-bit data
 - 10001 = 18-bit data
 - 10000 = 17-bit data
 - 01111 = 16-bit data
 - 01110 = 15-bit data
 - 01101 = 14-bit data
 - 01100 = 13-bit data
 - 01011 = 12-bit data
 - 01010 = 11-bit data
 - 01001 = 10-bit data
 - 01000 = 9-bit data
 - 00111 = 8-bit data
 - 00110 = 7-bit data
 - 00101 = 6-bit data
 - 00100 = 5-bit data
 - 00011 = 4-bit data
 - 00010 = 3-bit data
 - 00001 = 2-bit data
 - 00000 = See MODE[32,16] bits in SPIxCON1L[11:10]

- Note 1:** These bits are effective when AUDEN = 0 only.
Note 2: Varying the length by changing these bits does not affect the depth of the TX/RX FIFO.

PIC24FJ256GA705 FAMILY

REGISTER 17-4: SPIxSTATL: SPIx STATUS REGISTER LOW

U-0	U-0	U-0	HS/R/C-0	HSC/R-0	U-0	U-0	HSC/R-0
—	—	—	FRMERR	SPIBUSY	—	—	SPITUR ⁽¹⁾
bit 15							bit 8

HSC/R-0	HS/R/C-0	HSC/R-1	U-0	HSC/R-1	U-0	HSC/R-0	HSC/R-0
SRMT	SPIROV	SPIRBE	—	SPITBE	—	SPITBF	SPIRBF
bit 7							bit 0

Legend:	C = Clearable bit	HS = Hardware Settable bit	x = Bit is unknown
R = Readable bit	W = Writable bit	'0' = Bit is cleared	HSC = Hardware Settable/Clearable bit
-n = Value at POR	'1' = Bit is set	U = Unimplemented bit, read as '0'	

bit 15-13 **Unimplemented:** Read as '0'

bit 12 **FRMERR:** SPIx Frame Error Status bit

1 = Frame error is detected
0 = No frame error is detected

bit 11 **SPIBUSY:** SPIx Activity Status bit

1 = Module is currently busy with some transactions
0 = No ongoing transactions (at time of read)

bit 10-9 **Unimplemented:** Read as '0'

bit 8 **SPITUR:** SPIx Transmit Underrun Status bit⁽¹⁾

1 = Transmit buffer has encountered a Transmit Underrun condition
0 = Transmit buffer does not have a Transmit Underrun condition

bit 7 **SRMT:** Shift Register Empty Status bit

1 = No current or pending transactions (i.e., neither SPIxTXB or SPIxTXSR contains data to transmit)
0 = Current or pending transactions

bit 6 **SPIROV:** SPIx Receive Overflow Status bit

1 = A new byte/half-word/word has been completely received when the SPIxRXB is full
0 = No overflow

bit 5 **SPIRBE:** SPIx RX Buffer Empty Status bit

1 = RX buffer is empty
0 = RX buffer is not empty

Standard Buffer Mode:

Automatically set in hardware when SPIxBUF is read from, reading SPIxRXB. Automatically cleared in hardware when SPIx transfers data from SPIxRXSR to SPIxRXB.

Enhanced Buffer Mode:

Indicates RXELM[5:0] = 6'b000000.

bit 4 **Unimplemented:** Read as '0'

bit 3 **SPITBE:** SPIx Transmit Buffer Empty Status bit

1 = SPIxTXB is empty
0 = SPIxTXB is not empty

Standard Buffer Mode:

Automatically set in hardware when SPIx transfers data from SPIxTXB to SPIxTXSR. Automatically cleared in hardware when SPIxBUF is written, loading SPIxTXB.

Enhanced Buffer Mode:

Indicates TXELM[5:0] = 6'b000000.

Note 1: SPITUR is cleared when SPIEN = 0. When IGNTUR = 1, SPITUR provides dynamic status of the Transmit Underrun condition, but does not stop RX/TX operation and does not need to be cleared by software.

PIC24FJ256GA705 FAMILY

REGISTER 17-4: SPIxSTATL: SPIx STATUS REGISTER LOW (CONTINUED)

bit 2 **Unimplemented:** Read as '0'

bit 1 **SPITBF:** SPIx Transmit Buffer Full Status bit

1 = SPIxTXB is full

0 = SPIxTXB not full

Standard Buffer Mode:

Automatically set in hardware when SPIxBUF is written, loading SPIxTXB. Automatically cleared in hardware when SPIx transfers data from SPIxTXB to SPIxTXSR.

Enhanced Buffer Mode:

Indicates TXELM[5:0] = 6'b111111.

bit 0 **SPIRBF:** SPIx Receive Buffer Full Status bit

1 = SPIxRXB is full

0 = SPIxRXB is not full

Standard Buffer Mode:

Automatically set in hardware when SPIx transfers data from SPIxRXSR to SPIxRXB. Automatically cleared in hardware when SPIxBUF is read from, reading SPIxRXB.

Enhanced Buffer Mode:

Indicates RXELM[5:0] = 6'b111111.

Note 1: SPITUR is cleared when SPIEN = 0. When IGNTUR = 1, SPITUR provides dynamic status of the Transmit Underrun condition, but does not stop RX/TX operation and does not need to be cleared by software.

PIC24FJ256GA705 FAMILY

REGISTER 17-5: SPIxSTATH: SPIx STATUS REGISTER HIGH⁽⁴⁾

U-0	U-0	HSC/R-0	HSC/R-0	HSC/R-0	HSC/R-0	HSC/R-0	HSC/R-0
—	—	RXELM[5:0] ^(1,2,3)					
bit 15							bit 8

U-0	U-0	HSC/R-0	HSC/R-0	HSC/R-0	HSC/R-0	HSC/R-0	HSC/R-0
—	—	TXELM[5:0] ^(1,2,3)					
bit 7							bit 0

Legend:	HSC = Hardware Settable/Clearable bit		
R = Readable bit	W = Writable bit	U = Unimplemented bit, read as '0'	
-n = Value at POR	'1' = Bit is set	'0' = Bit is cleared	x = Bit is unknown

bit 15-14 **Unimplemented:** Read as '0'

bit 13-8 **RXELM[5:0]:** Receive Buffer Element Count bits (valid in Enhanced Buffer mode)^(1,2,3)

bit 7-6 **Unimplemented:** Read as '0'

bit 5-0 **TXELM[5:0]:** Transmit Buffer Element Count bits (valid in Enhanced Buffer mode)^(1,2,3)

- Note 1:** RXELM3 and TXELM3 bits are only present when FIFODEPTH = 8 or higher.
2: RXELM4 and TXELM4 bits are only present when FIFODEPTH = 16 or higher.
3: RXELM5 and TXELM5 bits are only present when FIFODEPTH = 32.
4: See the MODE32/16 bits in the SPIxCON1L register.

PIC24FJ256GA705 FAMILY

REGISTER 17-6: SPIxBUFL: SPIx BUFFER REGISTER LOW

R/W-0	R/W-0	R/W-0	R/W-0	R/W-0	R/W-0	R/W-0	R/W-0
DATA[15:8]							
bit 15							bit 8

R/W-0	R/W-0	R/W-0	R/W-0	R/W-0	R/W-0	R/W-0	R/W-0
DATA[7:0]							
bit 7							bit 0

Legend:

R = Readable bit W = Writable bit U = Unimplemented bit, read as '0'
 -n = Value at POR '1' = Bit is set '0' = Bit is cleared x = Bit is unknown

bit 15-0 **DATA[15:0]:** SPIx FIFO Data bits
 When the MODE[32,16] or WLENGTH[4:0] bits select 16 to 9-bit data, the SPIx only uses DATA[15:0].
 When the MODE[32,16] or WLENGTH[4:0] bits select 8 to 2-bit data, the SPIx only uses DATA[7:0].

REGISTER 17-7: SPIxBUFH: SPIx BUFFER REGISTER HIGH

R/W-0	R/W-0	R/W-0	R/W-0	R/W-0	R/W-0	R/W-0	R/W-0
DATA[31:24]							
bit 15							bit 8

R/W-0	R/W-0	R/W-0	R/W-0	R/W-0	R/W-0	R/W-0	R/W-0
DATA[23:16]							
bit 7							bit 0

Legend:

R = Readable bit W = Writable bit U = Unimplemented bit, read as '0'
 -n = Value at POR '1' = Bit is set '0' = Bit is cleared x = Bit is unknown

bit 15-0 **DATA[31:16]:** SPIx FIFO Data bits
 When the MODE[32,16] or WLENGTH[4:0] bits select 32 to 25-bit data, the SPIx uses DATA[31:16].
 When the MODE[32,16] or WLENGTH[4:0] bits select 24 to 17-bit data, the SPIx only uses DATA[23:16].

PIC24FJ256GA705 FAMILY

REGISTER 17-8: SPIxBRGL: SPIx BAUD RATE GENERATOR REGISTER LOW

U-0	U-0	U-0	R/W-0	R/W-0	R/W-0	R/W-0	R/W-0
—	—	—	BRG[12:8] ⁽¹⁾				
bit 15							bit 8

R/W-0	R/W-0	R/W-0	R/W-0	R/W-0	R/W-0	R/W-0	R/W-0
BRG[7:0] ⁽¹⁾							
bit 7							bit 0

Legend:

R = Readable bit

W = Writable bit

U = Unimplemented bit, read as '0'

-n = Value at POR

'1' = Bit is set

'0' = Bit is cleared

x = Bit is unknown

bit 15-13 **Unimplemented:** Read as '0'

bit 12-0 **BRG[12:0]:** SPIx Baud Rate Generator Divisor bits⁽¹⁾

Note 1: Changing the BRG value when SPIEN = 1 causes undefined behavior.

PIC24FJ256GA705 FAMILY

REGISTER 17-9: SPIxIMSKL: SPIx INTERRUPT MASK REGISTER LOW

U-0	U-0	U-0	R/W-0	R/W-0	U-0	U-0	R/W-0
—	—	—	FRMERREN	BUSYEN	—	—	SPITUREN
bit 15							bit 8

R/W-0	R/W-0	R/W-0	U-0	R/W-0	U-0	R/W-0	R/W-0
SRMTEN	SPIROVEN	SPIRBEN	—	SPITBEN	—	SPITBFEN	SPIRBFEN
bit 7							bit 0

Legend:

R = Readable bit W = Writable bit U = Unimplemented bit, read as '0'
 -n = Value at POR '1' = Bit is set '0' = Bit is cleared x = Bit is unknown

- bit 15-13 **Unimplemented:** Read as '0'
- bit 12 **FRMERREN:** Enable Interrupt Events via FRMERR bit
 1 = Frame error generates an interrupt event
 0 = Frame error does not generate an interrupt event
- bit 11 **BUSYEN:** Enable Interrupt Events via SPIBUSY bit
 1 = SPIBUSY generates an interrupt event
 0 = SPIBUSY does not generate an interrupt event
- bit 10-9 **Unimplemented:** Read as '0'
- bit 8 **SPITUREN:** Enable Interrupt Events via SPITUR bit
 1 = Transmit Underrun (TUR) generates an interrupt event
 0 = Transmit Underrun does not generate an interrupt event
- bit 7 **SRMTEN:** Enable Interrupt Events via SRMT bit
 1 = Shift Register Empty (SRMT) generates interrupt events
 0 = Shift Register Empty does not generate interrupt events
- bit 6 **SPIROVEN:** Enable Interrupt Events via SPIROV bit
 1 = SPIx Receive Overflow generates an interrupt event
 0 = SPIx Receive Overflow does not generate an interrupt event
- bit 5 **SPIRBEN:** Enable Interrupt Events via SPIRBE bit
 1 = SPIx Receive Buffer Empty generates an interrupt event
 0 = SPIx Receive Buffer Empty does not generate an interrupt event
- bit 4 **Unimplemented:** Read as '0'
- bit 3 **SPITBEN:** Enable Interrupt Events via SPITBE bit
 1 = SPIx Transmit Buffer Empty generates an interrupt event
 0 = SPIx Transmit Buffer Empty does not generate an interrupt event
- bit 2 **Unimplemented:** Read as '0'
- bit 1 **SPITBFEN:** Enable Interrupt Events via SPITBF bit
 1 = SPIx Transmit Buffer Full generates an interrupt event
 0 = SPIx Transmit Buffer Full does not generate an interrupt event
- bit 0 **SPIRBFEN:** Enable Interrupt Events via SPIRBF bit
 1 = SPIx Receive Buffer Full generates an interrupt event
 0 = SPIx Receive Buffer Full does not generate an interrupt event

REGISTER 17-10: SPIxIMSKH: SPIx INTERRUPT MASK REGISTER HIGH

R/W-0	U-0	R/W-0	R/W-0	R/W-0	R/W-0	R/W-0	R/W-0
RXWIEN	—	RXMSK5 ⁽¹⁾	RXMSK4 ^(1,4)	RXMSK3 ^(1,3)	RXMSK2 ^(1,2)	RXMSK1 ⁽¹⁾	RXMSK0 ⁽¹⁾
bit 15							bit 8

R/W-0	U-0	R/W-0	R/W-0	R/W-0	R/W-0	R/W-0	R/W-0
TXWIEN	—	TXMSK5 ⁽¹⁾	TXMSK4 ^(1,4)	TXMSK3 ^(1,3)	TXMSK2 ^(1,2)	TXMSK1 ⁽¹⁾	TXMSK0 ⁽¹⁾
bit 7							bit 0

Legend:

R = Readable bit W = Writable bit U = Unimplemented bit, read as '0'
 -n = Value at POR '1' = Bit is set '0' = Bit is cleared x = Bit is unknown

- bit 15 **RXWIEN:** Receive Watermark Interrupt Enable bit
 1 = Triggers receive buffer element watermark interrupt when RXMSK[5:0] ≤ RXELM[5:0]
 0 = Disables receive buffer element watermark interrupt
- bit 14 **Unimplemented:** Read as '0'
- bit 13-8 **RXMSK[5:0]:** RX Buffer Mask bits^(1,2,3,4)
 RX mask bits; used in conjunction with the RXWIEN bit.
- bit 7 **TXWIEN:** Transmit Watermark Interrupt Enable bit
 1 = Triggers transmit buffer element watermark interrupt when TXMSK[5:0] = TXELM[5:0]
 0 = Disables transmit buffer element watermark interrupt
- bit 6 **Unimplemented:** Read as '0'
- bit 5-0 **TXMSK[5:0]:** TX Buffer Mask bits^(1,2,3,4)
 TX mask bits; used in conjunction with the TXWIEN bit.

- Note 1:** Mask values higher than FIFODEPTH are not valid. The module will not trigger a match for any value in this case.
- 2:** RXMSK2 and TXMSK2 bits are only present when FIFODEPTH = 8 or higher.
 - 3:** RXMSK3 and TXMSK3 bits are only present when FIFODEPTH = 16 or higher.
 - 4:** RXMSK4 and TXMSK4 bits are only present when FIFODEPTH = 32.

PIC24FJ256GA705 FAMILY

REGISTER 17-11: SPIxURDTL: SPIx UNDERRUN DATA REGISTER LOW

R/W-0	R/W-0	R/W-0	R/W-0	R/W-0	R/W-0	R/W-0	R/W-0
URDATA[15:8]							
bit 15				bit 8			

R/W-0	R/W-0	R/W-0	R/W-0	R/W-0	R/W-0	R/W-0	R/W-0
URDATA[7:0]							
bit 7				bit 0			

Legend:

R = Readable bit W = Writable bit U = Unimplemented bit, read as '0'
 -n = Value at POR '1' = Bit is set '0' = Bit is cleared x = Bit is unknown

bit 15-0 **URDATA[15:0]:** SPIx Underrun Data bits
 These bits are only used when URDTEN = 1. This register holds the data to transmit when a Transmit Underrun condition occurs.
 When the MODE[32,16] or WLENGTH[4:0] bits select 16 to 9-bit data, the SPIx only uses URDATA[15:0].
 When the MODE[32,16] or WLENGTH[4:0] bits select 8 to 2-bit data, the SPIx only uses URDATA[7:0].

REGISTER 17-12: SPIxURDTH: SPIx UNDERRUN DATA REGISTER HIGH

R/W-0	R/W-0	R/W-0	R/W-0	R/W-0	R/W-0	R/W-0	R/W-0
URDATA[31:24]							
bit 15				bit 8			

R/W-0	R/W-0	R/W-0	R/W-0	R/W-0	R/W-0	R/W-0	R/W-0
URDATA[23:16]							
bit 7				bit 0			

Legend:

R = Readable bit W = Writable bit U = Unimplemented bit, read as '0'
 -n = Value at POR '1' = Bit is set '0' = Bit is cleared x = Bit is unknown

bit 15-0 **URDATA[31:16]:** SPIx Underrun Data bits
 These bits are only used when URDTEN = 1. This register holds the data to transmit when a Transmit Underrun condition occurs.
 When the MODE[32,16] or WLENGTH[4:0] bits select 32 to 25-bit data, the SPIx only uses URDATA[31:16]. When the MODE[32,16] or WLENGTH[4:0] bits select 24 to 17-bit data, the SPIx only uses URDATA[23:16].

FIGURE 17-2: SPIx MASTER/SLAVE CONNECTION (STANDARD MODE)

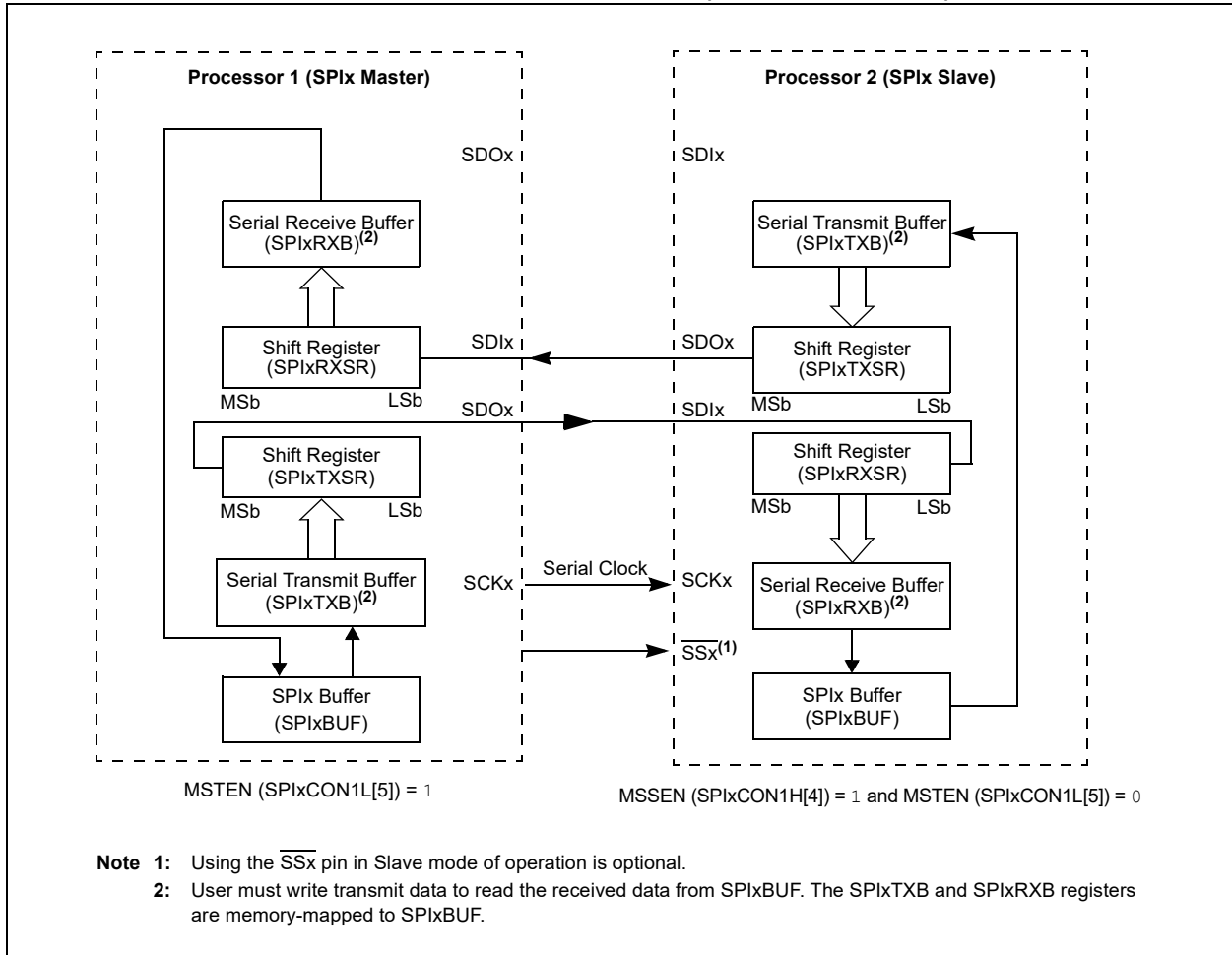

PIC24FJ256GA705 FAMILY

FIGURE 17-3: SPIx MASTER/SLAVE CONNECTION (ENHANCED BUFFER MODES)

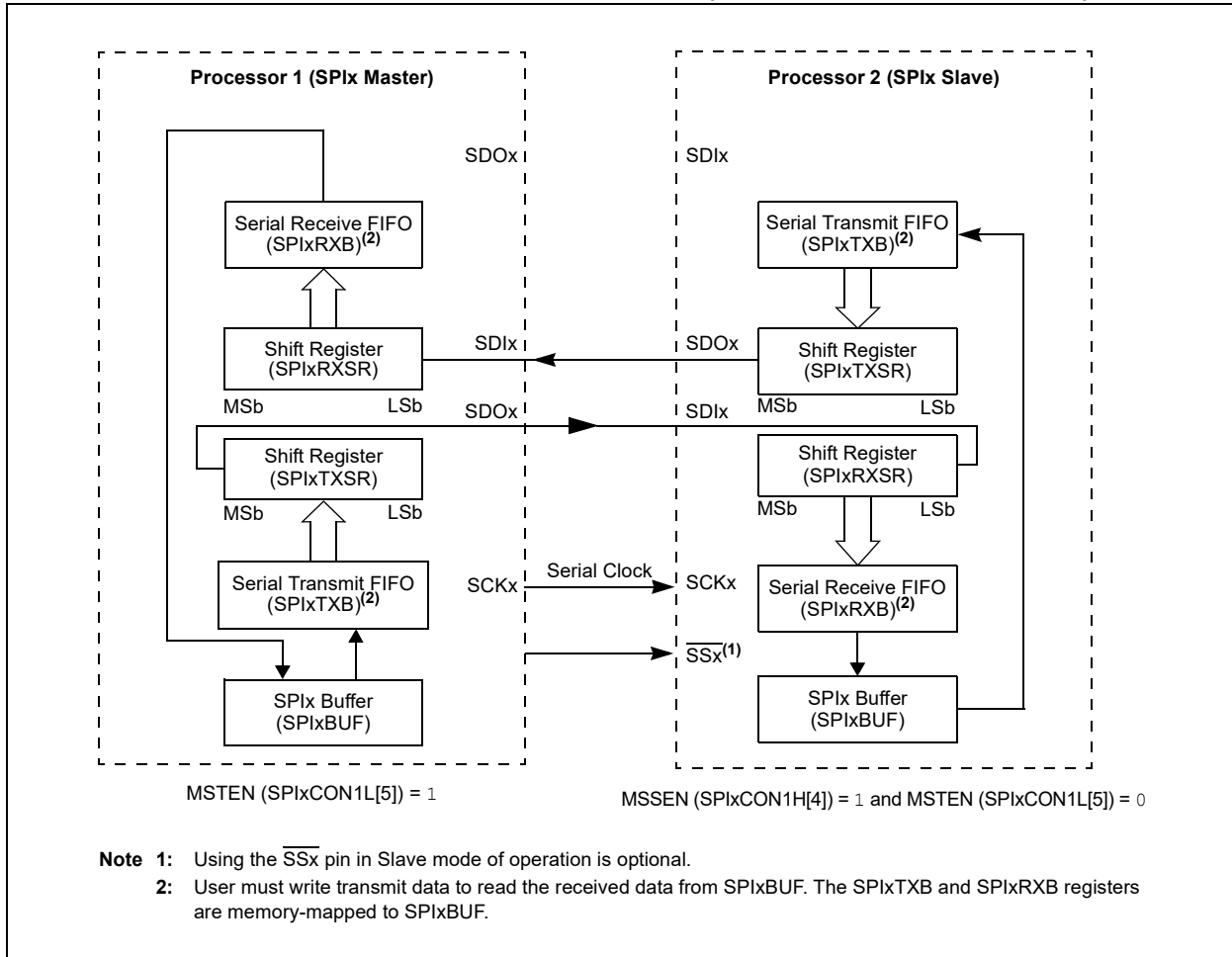
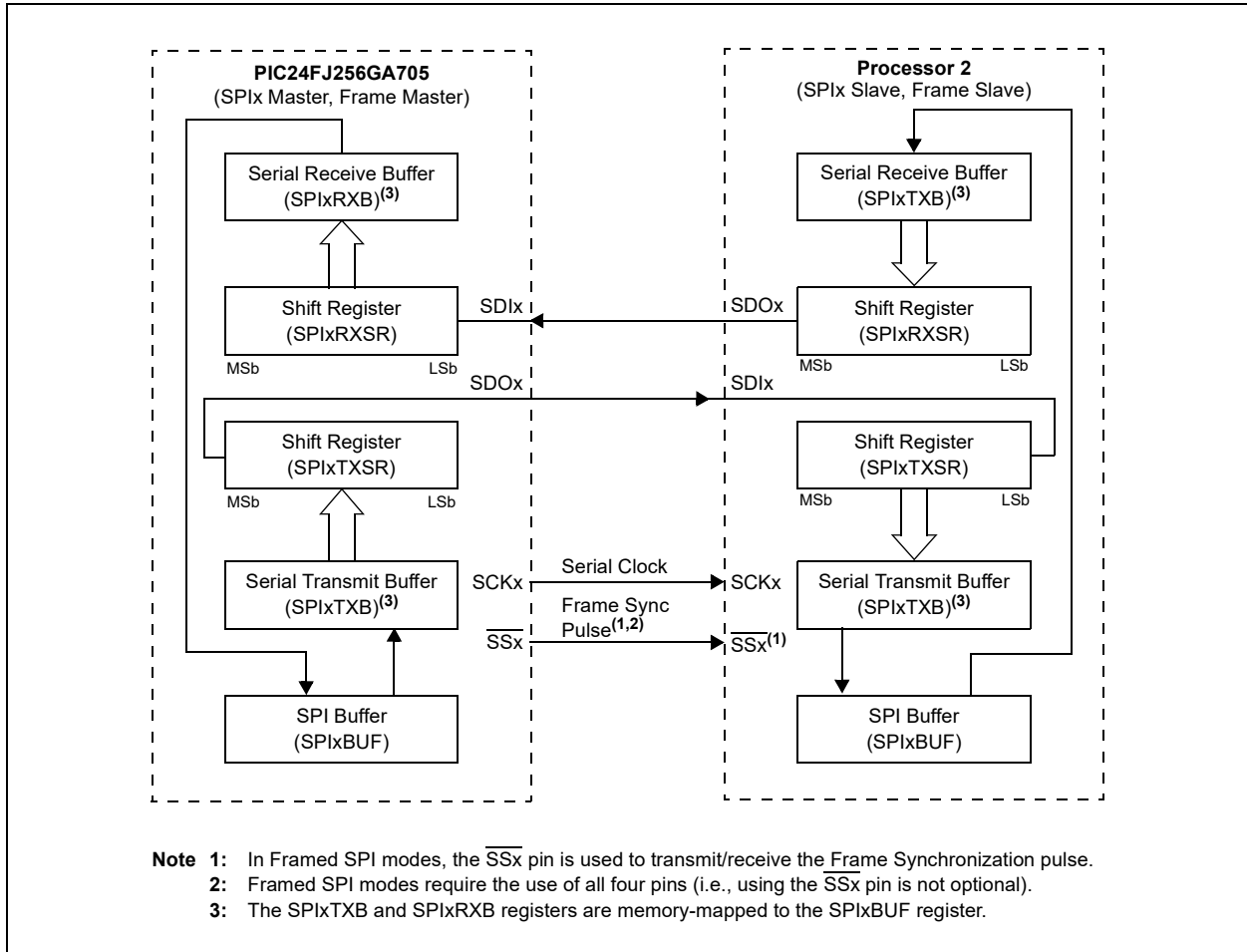

FIGURE 17-4: SPIx MASTER, FRAME MASTER CONNECTION DIAGRAM



PIC24FJ256GA705 FAMILY

FIGURE 17-5: SPIx MASTER, FRAME SLAVE CONNECTION DIAGRAM

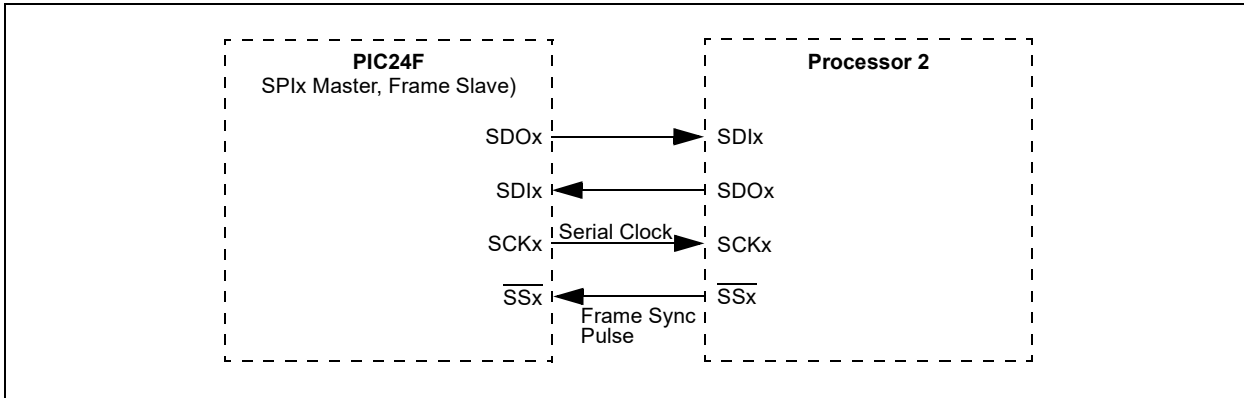

FIGURE 17-6: SPIx SLAVE, FRAME MASTER CONNECTION DIAGRAM

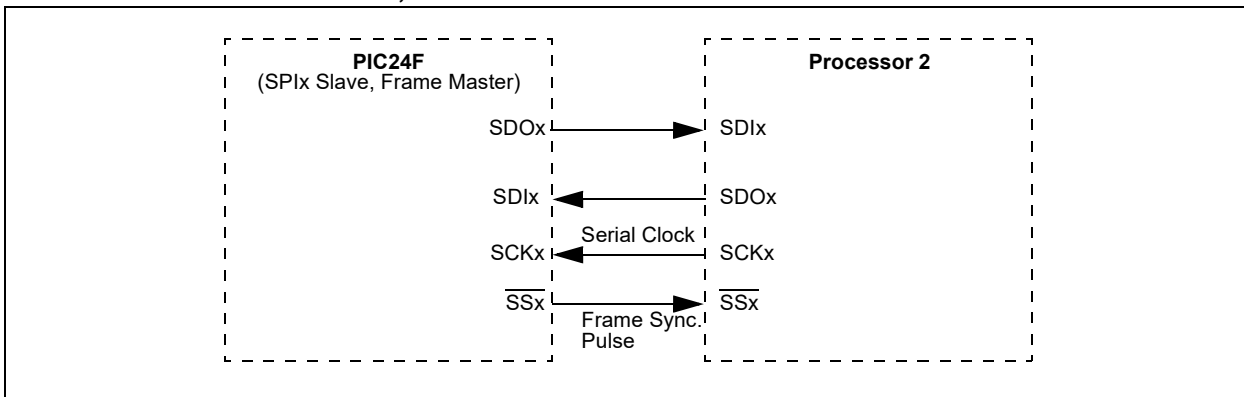
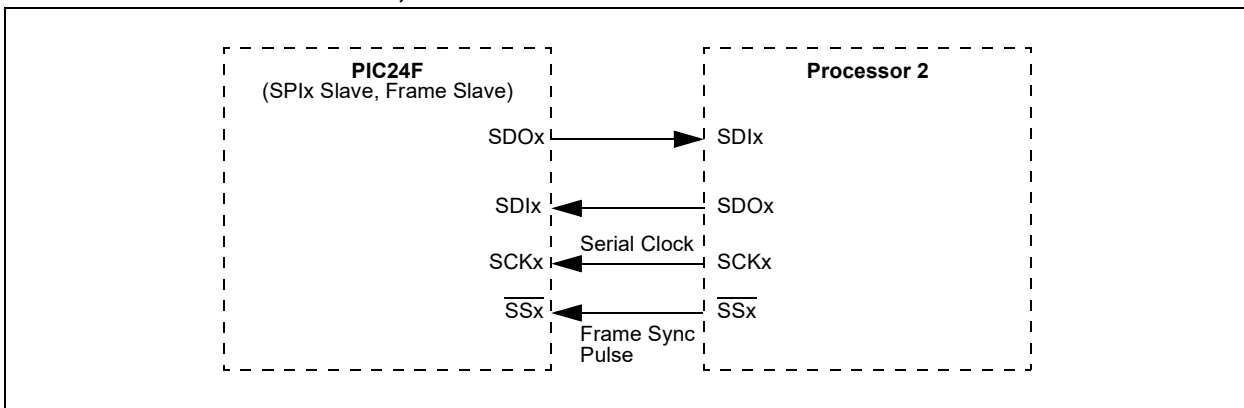

FIGURE 17-7: SPIx SLAVE, FRAME SLAVE CONNECTION DIAGRAM



EQUATION 17-1: RELATIONSHIP BETWEEN DEVICE AND SPIx CLOCK SPEED

$$\text{Baud Rate} = \frac{\text{FPB}}{(2 * (\text{SPIxBRG} + 1))}$$

Where:

FPB is the Peripheral Bus Clock Frequency.

18.0 INTER-INTEGRATED CIRCUIT (I²C)

Note: This data sheet summarizes the features of this group of PIC24F devices. It is not intended to be a comprehensive reference source. For more information, refer to “**Inter-Integrated Circuit (I²C)**” (www.microchip.com/DS70000195) in the “*dsPIC33/PIC24 Family Reference Manual*”. The information in this data sheet supersedes the information in the FRM.

The Inter-Integrated Circuit (I²C) module is a serial interface useful for communicating with other peripheral or microcontroller devices. These peripheral devices may be serial EEPROMs, display drivers, A/D Converters, etc.

The I²C module supports these features:

- Independent Master and Slave Logic
- 7-Bit and 10-Bit Device Addresses
- General Call Address as Defined in the I²C Protocol
- Clock Stretching to Provide Delays for the Processor to Respond to a Slave Data Request
- Both 100 kHz and 400 kHz Bus Specifications
- Configurable Address Masking
- Multi-Master modes to Prevent Loss of Messages in Arbitration
- Bus Repeater mode, Allowing the Acceptance of All Messages as a Slave, regardless of the Address
- Automatic SCL

A block diagram of the module is shown in [Figure 18-1](#).

18.1 Communicating as a Master in a Single Master Environment

The details of sending a message in Master mode depends on the communications protocol for the device being communicated with. Typically, the sequence of events is as follows:

1. Assert a Start condition on SDAx and SCLx.
2. Send the I²C device address byte to the Slave with a write indication.
3. Wait for and verify an Acknowledge from the Slave.
4. Send the first data byte (sometimes known as the command) to the Slave.
5. Wait for and verify an Acknowledge from the Slave.
6. Send the serial memory address low byte to the Slave.
7. Repeat Steps 4 and 5 until all data bytes are sent.
8. Assert a Repeated Start condition on SDAx and SCLx.
9. Send the device address byte to the Slave with a read indication.
10. Wait for and verify an Acknowledge from the Slave.
11. Enable Master reception to receive serial memory data.
12. Generate an ACK or NACK condition at the end of a received byte of data.
13. Generate a Stop condition on SDAx and SCLx.

PIC24FJ256GA705 FAMILY

FIGURE 18-1: I2Cx BLOCK DIAGRAM

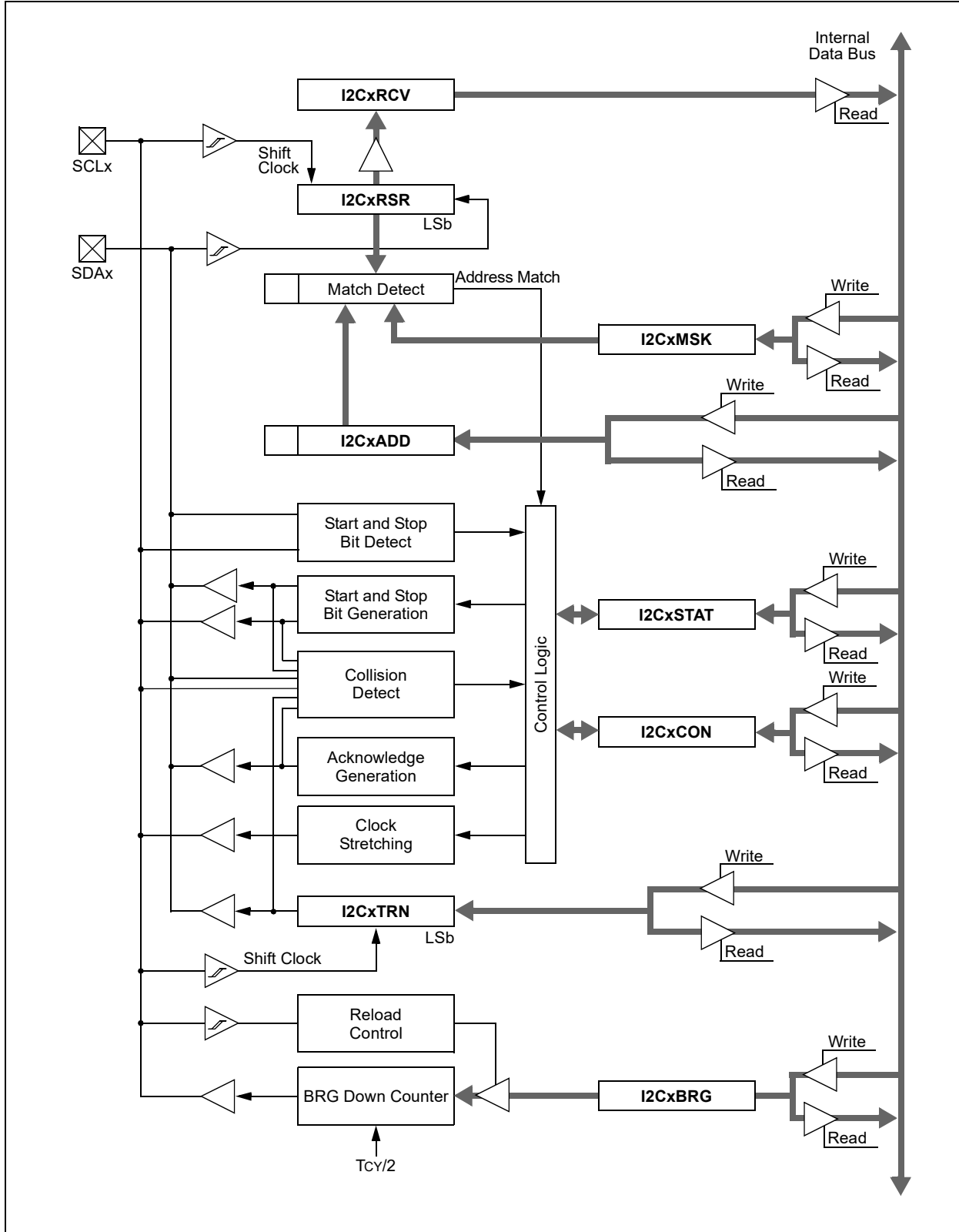

18.2 Setting Baud Rate When Operating as a Bus Master

To compute the Baud Rate Generator reload value, use [Equation 18-1](#).

EQUATION 18-1: COMPUTING BAUD RATE RELOAD VALUE^(1,2,3)

$$F_{SCL} = \frac{F_{CY}}{(I2CxBRG + 2) * 2}$$

or:

$$I2CxBRG = \left[\frac{F_{CY}}{(F_{SCL} * 2)} - 2 \right]$$

Note 1: Based on $F_{CY} = F_{OSC}/2$; Doze mode and PLL are disabled.

2: These clock rate values are for guidance only. The actual clock rate can be affected by various system-level parameters. The actual clock rate should be measured in its intended application.

3: BRG values of 0 and 1 are forbidden.

18.3 Slave Address Masking

The I2CxMSK register ([Register 18-4](#)) designates address bit positions as “don’t care” for both 7-Bit and 10-Bit Addressing modes. Setting a particular bit location (= 1) in the I2CxMSK register causes the Slave module to respond, whether the corresponding address bit value is a ‘0’ or a ‘1’. For example, when I2CxMSK is set to ‘0010000000’, the Slave module will detect both addresses, ‘0000000000’ and ‘0010000000’.

To enable address masking, the Intelligent Peripheral Management Interface (IPMI) must be disabled by clearing the STRICT bit (I2CxCONL[11]).

Note: As a result of changes in the I²C protocol, the addresses in [Table 18-2](#) are reserved and will not be Acknowledged in Slave mode. This includes any address mask settings that include any of these addresses.

TABLE 18-1: I2Cx CLOCK RATES^(1,2)

Required System F _{SCL}	F _{CY}	I2CxBRG Value		Actual F _{SCL}
		(Decimal)	(Hexadecimal)	
100 kHz	16 MHz	78	4E	100 kHz
100 kHz	8 MHz	38	26	100 kHz
100 kHz	4 MHz	18	12	100 kHz
400 kHz	16 MHz	18	12	400 kHz
400 kHz	8 MHz	8	8	400 kHz
400 kHz	4 MHz	3	3	400 kHz
1 MHz	16 MHz	6	6	1.000 MHz
1 MHz	8 MHz	2	2	1.000 MHz

Note 1: Based on $F_{CY} = F_{OSC}/2$; Doze mode and PLL are disabled.

2: These clock rate values are for guidance only. The actual clock rate can be affected by various system-level parameters. The actual clock rate should be measured in its intended application.

TABLE 18-2: I2Cx RESERVED ADDRESSES⁽¹⁾

Slave Address	R/W Bit	Description
0000 000	0	General Call Address ⁽²⁾
0000 000	1	Start Byte
0000 001	x	Cbus Address
0000 01x	x	Reserved
0000 1xx	x	HS Mode Master Code
1111 0xx	x	10-Bit Slave Upper Byte ⁽³⁾
1111 1xx	x	Reserved

Note 1: The address bits listed here will never cause an address match independent of address mask settings.

2: This address will be Acknowledged only if GCEN = 1.

3: A match on this address can only occur on the upper byte in 10-Bit Addressing mode.

PIC24FJ256GA705 FAMILY

REGISTER 18-1: I2CxCONL: I2Cx CONTROL REGISTER LOW

R/W-0	U-0	HC/R/W-0	R/W-1	R/W-0	R/W-0	R/W-0	R/W-0
I2CEN	—	I2CSIDL	SCLREL ⁽¹⁾	STRICT	A10M	DISSLW	SMEN
bit 15							bit 8

R/W-0	R/W-0	R/W-0	HC/R/W-0	HC/R/W-0	HC/R/W-0	HC/R/W-0	HC/R/W-0
GCEN	STREN	ACKDT	ACKEN	RCEN	PEN	RSEN	SEN
bit 7							bit 0

Legend:	HC = Hardware Clearable bit		
R = Readable bit	W = Writable bit	U = Unimplemented bit, read as '0'	
-n = Value at POR	'1' = Bit is set	'0' = Bit is cleared	x = Bit is unknown

- bit 15 **I2CEN:** I2Cx Enable bit (writable from software only)
 1 = Enables the I2Cx module and configures the SDAx and SCLx pins as serial port pins
 0 = Disables the I2Cx module; all I²C pins are controlled by port functions
- bit 14 **Unimplemented:** Read as '0'
- bit 13 **I2CSIDL:** I2Cx Stop in Idle Mode bit
 1 = Discontinues module operation when device enters Idle mode
 0 = Continues module operation in Idle mode
- bit 12 **SCLREL:** SCLx Release Control bit (I²C Slave mode only)⁽¹⁾
 Module resets and (I2CEN = 0) sets SCLREL = 1.
If STREN = 0:⁽²⁾
 1 = Releases clock
 0 = Forces clock low (clock stretch)
If STREN = 1:
 1 = Releases clock
 0 = Holds clock low (clock stretch); user may program this bit to '0', clock stretch at next SCLx low
- bit 11 **STRICT:** I2Cx Strict Reserved Address Rule Enable bit
 1 = Strict reserved addressing is enforced (for reserved addresses, refer to [Table 18-2](#))
 In Slave Mode: The device doesn't respond to reserved address space and addresses falling in that category are NACKed.
 In Master Mode: The device is allowed to generate addresses with reserved address space.
 0 = Reserved addressing would be Acknowledged
 In Slave Mode: The device will respond to an address falling in the reserved address space. When there is a match with any of the reserved addresses, the device will generate an ACK.
 In Master Mode: Reserved.
- bit 10 **A10M:** 10-Bit Slave Address Flag bit
 1 = I2CxADD is a 10-bit Slave address
 0 = I2CxADD is a 7-bit Slave address
- bit 9 **DISSLW:** Slew Rate Control Disable bit
 1 = Slew rate control is disabled for Standard Speed mode (100 kHz, also disabled for 1 MHz mode)
 0 = Slew rate control is enabled for High-Speed mode (400 kHz)

Note 1: Automatically cleared to '0' at the beginning of Slave transmission; automatically cleared to '0' at the end of Slave reception. The user software must provide a delay between writing to the transmit buffer and setting the SCLREL bit. This delay must be greater than the minimum setup time for Slave transmissions, as specified in [Section 32.0 "Electrical Characteristics"](#).

2: Automatically cleared to '0' at the beginning of Slave transmission.

REGISTER 18-1: I2CxCONL: I2Cx CONTROL REGISTER LOW (CONTINUED)

bit 8	SMEN: SMBus Input Levels Enable bit 1 = Enables input logic so thresholds are compliant with the SMBus specification 0 = Disables SMBus-specific inputs
bit 7	GCEN: General Call Enable bit (I ² C Slave mode only) 1 = Enables interrupt when a general call address is received in I2CxRSR; module is enabled for reception 0 = General call address is disabled
bit 6	STREN: SCLx Clock Stretch Enable bit In I ² C Slave mode only; used in conjunction with the SCLREL bit. 1 = Enables clock stretching 0 = Disables clock stretching
bit 5	ACKDT: Acknowledge Data bit In I ² C Master mode during Master Receive mode. The value that will be transmitted when the user initiates an Acknowledge sequence at the end of a receive. In I ² C Slave mode when AHEN = 1 or DHEN = 1. The value that the Slave will transmit when it initiates an Acknowledge sequence at the end of an address or data reception. 1 = NACK is sent 0 = ACK is sent
bit 4	ACKEN: Acknowledge Sequence Enable bit In I ² C Master mode only; applicable during Master Receive mode. 1 = Initiates Acknowledge sequence on SDAx and SCLx pins, and transmits the ACKDT data bit 0 = Acknowledge sequence is Idle
bit 3	RCEN: Receive Enable bit (I ² C Master mode only) 1 = Enables Receive mode for I ² C; automatically cleared by hardware at the end of the 8-bit receive data byte 0 = Receive sequence is not in progress
bit 2	PEN: Stop Condition Enable bit (I ² C Master mode only) 1 = Initiates Stop condition on the SDAx and SCLx pins 0 = Stop condition is Idle
bit 1	RSEN: Restart Condition Enable bit (I ² C Master mode only) 1 = Initiates Restart condition on the SDAx and SCLx pins 0 = Restart condition is Idle
bit 0	SEN: Start Condition Enable bit (I ² C Master mode only) 1 = Initiates Start condition on the SDAx and SCLx pins 0 = Start condition is Idle

Note 1: Automatically cleared to '0' at the beginning of Slave transmission; automatically cleared to '0' at the end of Slave reception. The user software must provide a delay between writing to the transmit buffer and setting the SCLREL bit. This delay must be greater than the minimum setup time for Slave transmissions, as specified in [Section 32.0 "Electrical Characteristics"](#).

2: Automatically cleared to '0' at the beginning of Slave transmission.

PIC24FJ256GA705 FAMILY

REGISTER 18-2: I2CxCONH: I2Cx CONTROL REGISTER HIGH

U-0	U-0	U-0	U-0	U-0	U-0	U-0	U-0
—	—	—	—	—	—	—	—
bit 15							bit 8

U-0	R/W-0	R/W-0	R/W-0	R/W-0	R/W-0	R/W-0	R/W-0
—	PCIE	SCIE	BOEN	SDAHT ⁽¹⁾	SBCDE	AHEN	DHEN
bit 7							bit 0

Legend:

R = Readable bit W = Writable bit U = Unimplemented bit, read as '0'
 -n = Value at POR '1' = Bit is set '0' = Bit is cleared x = Bit is unknown

- bit 15-7 **Unimplemented:** Read as '0'
- bit 6 **PCIE:** Stop Condition Interrupt Enable bit (I²C Slave mode only)
 1 = Enables interrupt on detection of Stop condition
 0 = Stop detection interrupts are disabled
- bit 5 **SCIE:** Start Condition Interrupt Enable bit (I²C Slave mode only)
 1 = Enables interrupt on detection of Start or Restart conditions
 0 = Start detection interrupts are disabled
- bit 4 **BOEN:** Buffer Overwrite Enable bit (I²C Slave mode only)
 1 = I2CxRCV is updated and an ACK is generated for a received address/data byte, ignoring the state of the I2COV bit only if RBF bit = 0
 0 = I2CxRCV is only updated when I2COV is clear
- bit 3 **SDAHT:** SDAx Hold Time Selection bit⁽¹⁾
 1 = Minimum of 300 ns hold time on SDAx after the falling edge of SCLx
 0 = Minimum of 100 ns hold time on SDAx after the falling edge of SCLx
- bit 2 **SBCDE:** Slave Mode Bus Collision Detect Enable bit (I²C Slave mode only)
 If, on the rising edge of SCLx, SDAx is sampled low when the module is outputting a High state, the BCL bit is set and the bus goes Idle. This Detection mode is only valid during data and ACK transmit sequences.
 1 = Enables Slave bus collision interrupts
 0 = Slave bus collision interrupts are disabled
- bit 1 **AHEN:** Address Hold Enable bit (I²C Slave mode only)
 1 = Following the 8th falling edge of SCLx for a matching received address byte; SCLREL bit (I2CxCONL[12]) will be cleared and SCLx will be held low
 0 = Address holding is disabled
- bit 0 **DHEN:** Data Hold Enable bit (I²C Slave mode only)
 1 = Following the 8th falling edge of SCLx for a received data byte; Slave hardware clears the SCLREL bit (I2CxCONL[12]) and SCLx is held low
 0 = Data holding is disabled

Note 1: This bit must be set to '0' for 1 MHz operation.

PIC24FJ256GA705 FAMILY

REGISTER 18-3: I2CxSTAT: I2Cx STATUS REGISTER

HSC/R-0	HSC/R-0	HSC/R-0	U-0	U-0	HSC/R/C-0	HSC/R-0	HSC/R-0
ACKSTAT	TRSTAT	ACKTIM	—	—	BCL	GCSTAT	ADD10
bit 15						bit 8	

HS/R/C-0	HS/R/C-0	HSC/R-0	HSC/R/C-0	HSC/R/C-0	HSC/R-0	HSC/R-0	HSC/R-0
IWCOL	I2COV	D/A	P	S	R/W	RBF	TBF
bit 7						bit 0	

Legend:	C = Clearable bit	HS = Hardware Settable bit	'0' = Bit is cleared
R = Readable bit	W = Writable bit	U = Unimplemented bit, read as '0'	
-n = Value at POR	'1' = Bit is set	HSC = Hardware Settable/Clearable bit	

- bit 15 **ACKSTAT:** Acknowledge Status bit (updated in all Master and Slave modes)
1 = Acknowledge was not received from Slave
0 = Acknowledge was received from Slave
- bit 14 **TRSTAT:** Transmit Status bit (when operating as I²C Master; applicable to Master transmit operation)
1 = Master transmit is in progress (8 bits + ACK)
0 = Master transmit is not in progress
- bit 13 **ACKTIM:** Acknowledge Time Status bit (valid in I²C Slave mode only)
1 = Indicates I²C bus is in an Acknowledge sequence, set on 8th falling edge of SCLx clock
0 = Not an Acknowledge sequence, cleared on 9th rising edge of SCLx clock
- bit 12-11 **Unimplemented:** Read as '0'
- bit 10 **BCL:** Bus Collision Detect bit (Master/Slave mode; cleared when I²C module is disabled, I2CEN = 0)
1 = A bus collision has been detected during a Master or Slave transmit operation
0 = No bus collision has been detected
- bit 9 **GCSTAT:** General Call Status bit (cleared after Stop detection)
1 = General call address was received
0 = General call address was not received
- bit 8 **ADD10:** 10-Bit Address Status bit (cleared after Stop detection)
1 = 10-bit address was matched
0 = 10-bit address was not matched
- bit 7 **IWCOL:** I2Cx Write Collision Detect bit
1 = An attempt to write to the I2CxTRN register failed because the I²C module is busy; must be cleared in software
0 = No collision
- bit 6 **I2COV:** I2Cx Receive Overflow Flag bit
1 = A byte was received while the I2CxRCV register is still holding the previous byte; I2COV is a “don't care” in Transmit mode, must be cleared in software
0 = No overflow
- bit 5 **D/A:** Data/Address bit (when operating as I²C Slave)
1 = Indicates that the last byte received was data
0 = Indicates that the last byte received or transmitted was an address
- bit 4 **P:** I2Cx Stop bit
Updated when Start, Reset or Stop is detected; cleared when the I²C module is disabled, I2CEN = 0.
1 = Indicates that a Stop bit has been detected last
0 = Stop bit was not detected last

PIC24FJ256GA705 FAMILY

REGISTER 18-3: I2CxSTAT: I2Cx STATUS REGISTER (CONTINUED)

- bit 3 **S:** I2Cx Start bit
 Updated when Start, Reset or Stop is detected; cleared when the I²C module is disabled, I2CEN = 0.
 1 = Indicates that a Start (or Repeated Start) bit has been detected last
 0 = Start (or Repeated Start) bit was not detected last
- bit 2 **R/W:** Read/Write Information bit (when operating as I²C Slave)
 1 = Read: Indicates the data transfer is output from the Slave
 0 = Write: Indicates the data transfer is input to the Slave
- bit 1 **RBF:** Receive Buffer Full Status bit
 1 = Receive is complete, I2CxRCV is full
 0 = Receive is not complete, I2CxRCV is empty
- bit 0 **TBF:** Transmit Buffer Full Status bit
 1 = Transmit is in progress, I2CxTRN is full (8 bits of data)
 0 = Transmit is complete, I2CxTRN is empty

REGISTER 18-4: I2CxMSK: I2Cx SLAVE MODE ADDRESS MASK REGISTER

U-0	U-0	U-0	U-0	U-0	U-0	R/W-0	R/W-0
—	—	—	—	—	—	MSK[9:8]	
bit 15							bit 8

R/W-0	R/W-0	R/W-0	R/W-0	R/W-0	R/W-0	R/W-0	R/W-0
MSK[7:0]							
bit 7							bit 0

Legend:

R = Readable bit	W = Writable bit	U = Unimplemented bit, read as '0'
-n = Value at POR	'1' = Bit is set	'0' = Bit is cleared x = Bit is unknown

- bit 15-10 **Unimplemented:** Read as '0'
- bit 9-0 **MSK[9:0]:** I2Cx Mask for Address Bit x Select bits
 1 = Enables masking for bit x of the incoming message address; bit match is not required in this position
 0 = Disables masking for bit x; bit match is required in this position

19.0 UNIVERSAL ASYNCHRONOUS RECEIVER TRANSMITTER (UART)

Note: This data sheet summarizes the features of this group of PIC24F devices. It is not intended to be a comprehensive reference source. For more information, refer to “**Universal Asynchronous Receiver Transmitter (UART)**” (www.microchip.com/DS70000582) in the “*dsPIC33/PIC24 Family Reference Manual*”. The information in this data sheet supersedes the information in the FRM.

The Universal Asynchronous Receiver Transmitter (UART) module is one of the serial I/O modules available in the PIC24F device family. The UART is a full-duplex, asynchronous system that can communicate with peripheral devices, such as personal computers, LIN/J2602, RS-232 and RS-485 interfaces. The module also supports a hardware flow control option with the \overline{UxCTS} and \overline{UxRTS} pins. The UART module includes an IrDA[®] encoder/decoder unit.

The PIC24FJ256GA705 family devices are equipped with two UART modules, referred to as UART1 and UART2.

The primary features of the UARTx modules are:

- Full-Duplex, 8 or 9-Bit Data Transmission through the $UxTX$ and $UxRX$ Pins
- Even, Odd or No Parity Options (for 8-bit data)
- One or Two Stop bits
- Hardware Flow Control Option with the \overline{UxCTS} and \overline{UxRTS} Pins
- Fully Integrated Baud Rate Generator with 16-Bit Prescaler
- Baud Rates Range from up to 1 Mbps and Down to 15 Hz at 16 MIPS in 16x mode

- Baud Rates Range from up to 4 Mbps and Down to 61 Hz at 16 MIPS in 4x mode
- 4-Deep, First-In-First-Out (FIFO) Transmit Data Buffer
- 4-Deep FIFO Receive Data Buffer
- Parity, Framing and Buffer Overrun Error Detection
- Support for 9-Bit mode with Address Detect (9th bit = 1)
- Separate Transmit and Receive Interrupts
- Loopback mode for Diagnostic Support
- Polarity Control for Transmit and Receive Lines
- Support for Sync and Break Characters
- Supports Automatic Baud Rate Detection
- IrDA[®] Encoder and Decoder Logic
- Includes DMA Support
- 16x Baud Clock Output for IrDA Support

A simplified block diagram of the UARTx module is shown in [Figure 19-1](#). The UARTx module consists of these key important hardware elements:

- Baud Rate Generator
- Asynchronous Transmitter
- Asynchronous Receiver

Note: Throughout this section, references to register and bit names that may be associated with a specific UART module are referred to generically by the use of ‘x’ in place of the specific module number. Thus, “ $UxSTA$ ” might refer to the Status register for either UART1 or UART2.

PIC24FJ256GA705 FAMILY

FIGURE 19-1: UARTx SIMPLIFIED BLOCK DIAGRAM

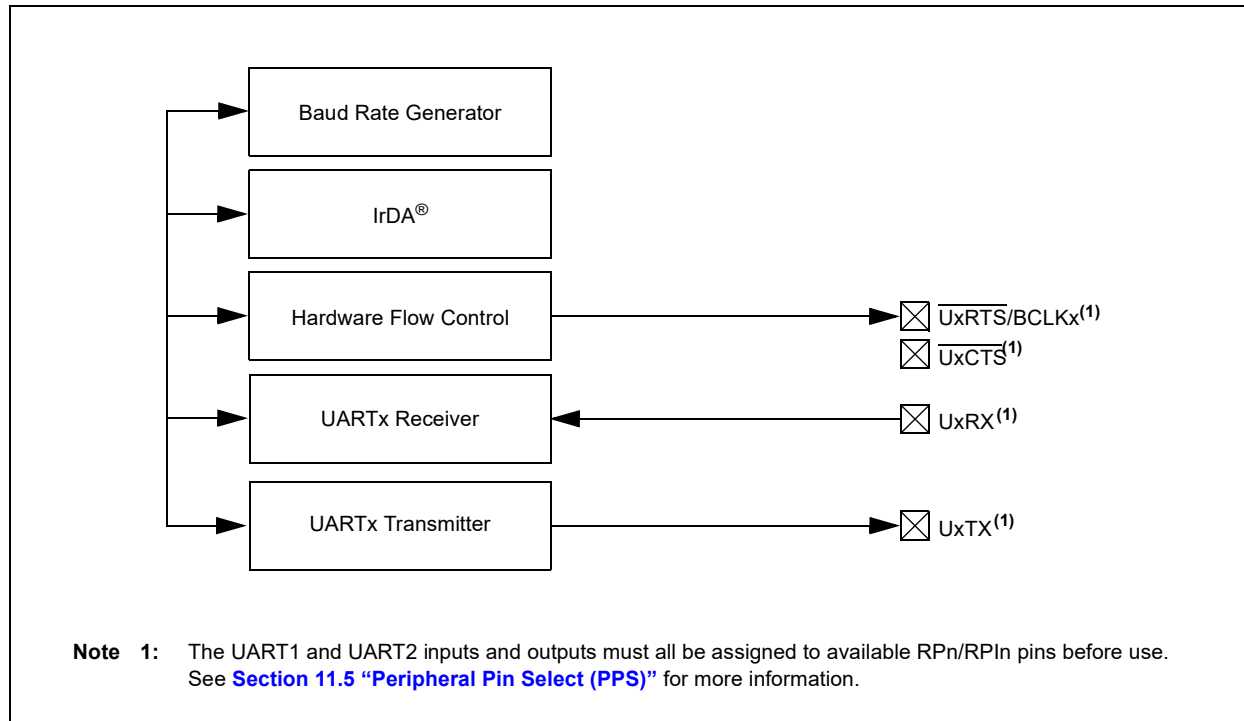

19.1 UARTx Baud Rate Generator (BRG)

The UARTx module includes a dedicated, 16-bit Baud Rate Generator. The UxBRG register controls the period of a free-running, 16-bit timer. Equation 19-1 shows the formula for computation of the baud rate when BRGH = 0.

EQUATION 19-1: UARTx BAUD RATE WITH BRGH = 0^(1,2)

$$\text{Baud Rate} = \frac{\text{FCY}}{16 \cdot (\text{UxBRG} + 1)}$$

$$\text{UxBRG} = \frac{\text{FCY}}{16 \cdot \text{Baud Rate}} - 1$$

Note 1: FCY denotes the instruction cycle clock frequency (FOSC/2).

2: Based on FCY = FOSC/2; Doze mode and PLL are disabled.

Example 19-1 shows the calculation of the baud rate error for the following conditions:

- FCY = 4 MHz
- Desired Baud Rate = 9600

The maximum baud rate (BRGH = 0) possible is FCY/16 (for UxBRG = 0) and the minimum baud rate possible is FCY/(16 * 65536).

EXAMPLE 19-1: BAUD RATE ERROR CALCULATION (BRGH = 0)⁽¹⁾

$$\text{Desired Baud Rate} = \text{FCY}/(16 (\text{UxBRG} + 1))$$

Solving for UxBRG Value:

$$\text{UxBRG} = ((\text{FCY}/\text{Desired Baud Rate})/16) - 1$$

$$\text{UxBRG} = ((4000000/9600)/16) - 1$$

$$\text{UxBRG} = 25$$

$$\text{Calculated Baud Rate} = 4000000/(16 (25 + 1))$$

$$= 9615$$

$$\text{Error} = (\text{Calculated Baud Rate} - \text{Desired Baud Rate})/\text{Desired Baud Rate}$$

$$= (9615 - 9600)/9600$$

$$= 0.16\%$$

Note 1: Based on FCY = FOSC/2; Doze mode and PLL are disabled.

Equation 19-2 shows the formula for computation of the baud rate when BRGH = 1.

EQUATION 19-2: UARTx BAUD RATE WITH BRGH = 1^(1,2)

$$\text{Baud Rate} = \frac{\text{FCY}}{4 \cdot (\text{UxBRG} + 1)}$$

$$\text{UxBRG} = \frac{\text{FCY}}{4 \cdot \text{Baud Rate}} - 1$$

Note 1: FCY denotes the instruction cycle clock frequency.

2: Based on FCY = FOSC/2; Doze mode and PLL are disabled.

The maximum baud rate (BRGH = 1) possible is FCY/4 (for UxBRG = 0) and the minimum baud rate possible is FCY/(4 * 65536).

Writing a new value to the UxBRG register causes the BRG timer to be reset (cleared). This ensures the BRG does not wait for a timer overflow before generating the new baud rate.

PIC24FJ256GA705 FAMILY

19.2 Transmitting in 8-Bit Data Mode

1. Set up the UARTx:
 - a) Write appropriate values for data, parity and Stop bits.
 - b) Write appropriate baud rate value to the UxBRG register.
 - c) Set up transmit and receive interrupt enable and priority bits.
2. Enable the UARTx.
3. Set the UTXEN bit (causes a transmit interrupt, two cycles after being set).
4. Write a data byte to the lower byte of the UxTXREG word. The value will be immediately transferred to the Transmit Shift Register (TSR) and the serial bit stream will start shifting out with the next rising edge of the baud clock.
5. Alternatively, the data byte may be transferred while UTXEN = 0 and then the user may set UTXEN. This will cause the serial bit stream to begin immediately because the baud clock will start from a cleared state.
6. A transmit interrupt will be generated as per interrupt control bits, UTXISEL[1:0].

19.3 Transmitting in 9-Bit Data Mode

1. Set up the UARTx (as described in [Section 19.2 “Transmitting in 8-Bit Data Mode”](#)).
2. Enable the UARTx.
3. Set the UTXEN bit (causes a transmit interrupt).
4. Write UxTXREG as a 16-bit value only.
5. A word write to UxTXREG triggers the transfer of the 9-bit data to the TSR. The serial bit stream will start shifting out with the first rising edge of the baud clock.
6. A transmit interrupt will be generated as per the setting of control bits, UTXISELx.

19.4 Break and Sync Transmit Sequence

The following sequence will send a message frame header, made up of a Break, followed by an auto-baud Sync byte.

1. Configure the UARTx for the desired mode.
2. Set UTXEN and UTXBRK to set up the Break character.
3. Load the UxTXREG with a dummy character to initiate transmission (value is ignored).
4. Write '55h' to UxTXREG; this loads the Sync character into the transmit FIFO.
5. After the Break has been sent, the UTXBRK bit is reset by hardware. The Sync character now transmits.

19.5 Receiving in 8-Bit or 9-Bit Data Mode

1. Set up the UARTx (as described in [Section 19.2 “Transmitting in 8-Bit Data Mode”](#)).
2. Enable the UARTx by setting the URXEN bit (UxSTA[12]).
3. A receive interrupt will be generated when one or more data characters have been received as per interrupt control bits, URXISEL[1:0].
4. Read the OERR bit to determine if an overrun error has occurred. The OERR bit must be reset in software.
5. Read UxRXREG.

The act of reading the UxRXREG character will move the next character to the top of the receive FIFO, including a new set of PERR and FERR values.

19.6 Operation of $\overline{\text{UxCTS}}$ and $\overline{\text{UxRTS}}$ Control Pins

$\overline{\text{UARTx}}$ Clear-to-Send ($\overline{\text{UxCTS}}$) and Request-to-Send ($\overline{\text{UxRTS}}$) are the two hardware controlled pins that are associated with the UARTx modules. These two pins allow the UARTx to operate in Simplex and Flow Control mode. They are implemented to control the transmission and reception between the Data Terminal Equipment (DTE). The UEN[1:0] bits in the UxMODE register configure these pins.

19.7 Infrared Support

The UARTx module provides two types of infrared UART support: one is the IrDA clock output to support an external IrDA encoder and decoder device (legacy module support), and the other is the full implementation of the IrDA encoder and decoder. Note that because the IrDA modes require a 16x baud clock, they will only work when the BRGH bit (UxMODE[3]) is '0'.

19.7.1 IrDA CLOCK OUTPUT FOR EXTERNAL IrDA SUPPORT

To support external IrDA encoder and decoder devices, the BCLKx pin (same as the $\overline{\text{UxRTS}}$ pin) can be configured to generate the 16x baud clock. When UEN[1:0] = 11, the BCLKx pin will output the 16x baud clock if the UARTx module is enabled; it can be used to support the IrDA codec chip.

19.7.2 BUILT-IN IrDA ENCODER AND DECODER

The UARTx has full implementation of the IrDA encoder and decoder as part of the UARTx module. The built-in IrDA encoder and decoder functionality is enabled using the IREN bit (UxMODE[12]). When enabled (IREN = 1), the receive pin (UxRX) acts as the input from the infrared receiver. The transmit pin (UxTX) acts as the output to the infrared transmitter.

REGISTER 19-1: UxMODE: UARTx MODE REGISTER

R/W-0	U-0	R/W-0	R/W-0	R/W-0	U-0	R/W-0	R/W-0
UARTEN ⁽¹⁾	—	USIDL	IREN ⁽²⁾	RTSMD	—	UEN1	UEN0
bit 15						bit 8	

HC/R/W-0	R/W-0	HC/R/W-0	R/W-0	R/W-0	R/W-0	R/W-0	R/W-0
WAKE	LPBACK	ABAUD	URXINV	BRGH	PDSEL1	PDSEL0	STSEL
bit 7						bit 0	

Legend:	HC = Hardware Clearable bit
R = Readable bit	W = Writable bit
-n = Value at POR	'1' = Bit is set
	U = Unimplemented bit, read as '0'
	'0' = Bit is cleared
	x = Bit is unknown

- bit 15 **UARTEN:** UARTx Enable bit⁽¹⁾
 1 = UARTx is enabled; all UARTx pins are controlled by UARTx as defined by UEN[1:0]
 0 = UARTx is disabled; all UARTx pins are controlled by port latches, UARTx power consumption is minimal
- bit 14 **Unimplemented:** Read as '0'
- bit 13 **USIDL:** UARTx Stop in Idle Mode bit
 1 = Discontinues module operation when device enters Idle mode
 0 = Continues module operation in Idle mode
- bit 12 **IREN:** IrDA[®] Encoder and Decoder Enable bit⁽²⁾
 1 = IrDA encoder and decoder are enabled
 0 = IrDA encoder and decoder are disabled
- bit 11 **RTSMD:** Mode Selection for $\overline{\text{UxRTS}}$ Pin bit
 1 = $\overline{\text{UxRTS}}$ pin is in Simplex mode
 0 = $\overline{\text{UxRTS}}$ pin is in Flow Control mode
- bit 10 **Unimplemented:** Read as '0'
- bit 9-8 **UEN[1:0]:** UARTx Enable bits
 11 = UxTX, UxRX and BCLKx pins are enabled and used; $\overline{\text{UxCTS}}$ pin is controlled by port latches
 10 = UxTX, UxRX, $\overline{\text{UxCTS}}$ and $\overline{\text{UxRTS}}$ pins are enabled and used
 01 = UxTX, UxRX and $\overline{\text{UxRTS}}$ pins are enabled and used; $\overline{\text{UxCTS}}$ pin is controlled by port latches
 00 = UxTX and UxRX pins are enabled and used; $\overline{\text{UxCTS}}$ and $\overline{\text{UxRTS}}$ /BCLKx pins are controlled by port latches
- bit 7 **WAKE:** Wake-up on Start Bit Detect During Sleep Mode Enable bit
 1 = UARTx continues to sample the UxRX pin; interrupt is generated on the falling edge, bit is cleared in hardware on the following rising edge
 0 = No wake-up is enabled
- bit 6 **LPBACK:** UARTx Loopback Mode Select bit
 1 = Enables Loopback mode
 0 = Loopback mode is disabled
- bit 5 **ABAUD:** Auto-Baud Enable bit
 1 = Enables baud rate measurement on the next character – requires reception of a Sync field (55h); cleared in hardware upon completion
 0 = Baud rate measurement is disabled or completed
- bit 4 **URXINV:** UARTx Receive Polarity Inversion bit
 1 = UxRX Idle state is '0'
 0 = UxRX Idle state is '1'

Note 1: If UARTEN = 1, the peripheral inputs and outputs must be configured to an available RPN/RPIn pin. For more information, see [Section 11.5 “Peripheral Pin Select \(PPS\)”](#).

2: This feature is only available for the 16x BRG mode (BRGH = 0).

PIC24FJ256GA705 FAMILY

REGISTER 19-1: UxMODE: UARTx MODE REGISTER (CONTINUED)

- bit 3 **BRGH:** High Baud Rate Enable bit
 1 = High-Speed mode (4 BRG clock cycles per bit)
 0 = Standard Speed mode (16 BRG clock cycles per bit)
- bit 2-1 **PDSEL[1:0]:** Parity and Data Selection bits
 11 = 9-bit data, no parity
 10 = 8-bit data, odd parity
 01 = 8-bit data, even parity
 00 = 8-bit data, no parity
- bit 0 **STSEL:** Stop Bit Selection bit
 1 = Two Stop bits
 0 = One Stop bit

- Note 1:** If `UARTEN = 1`, the peripheral inputs and outputs must be configured to an available `RPn/RPIn` pin. For more information, see [Section 11.5 “Peripheral Pin Select \(PPS\)”](#).
- 2:** This feature is only available for the 16x BRG mode (`BRGH = 0`).

REGISTER 19-2: UxSTA: UARTx STATUS AND CONTROL REGISTER

R/W-0	R/W-0	R/W-0	R/W-0	HC/R/W-0	R/W-0	HSC/R-0	HSC/R-1
UTXISEL1	UTXINV ⁽¹⁾	UTXISEL0	URXEN	UTXBRK	UTXEN ⁽²⁾	UTXBF	TRMT
bit 15						bit 8	

R/W-0	R/W-0	R/W-0	HSC/R-1	HSC/R-0	HSC/R-0	HS/R/C-0	HSC/R-0
URXISEL1	URXISEL0	ADDEN	RIDLE	PERR	FERR	OERR	URXDA
bit 7						bit 0	

Legend:	C = Clearable bit	HSC = Hardware Settable/Clearable bit
R = Readable bit	W = Writable bit	U = Unimplemented bit, read as '0'
-n = Value at POR	'1' = Bit is set	'0' = Bit is cleared
HS = Hardware Settable bit	HC = Hardware Clearable bit	x = Bit is unknown

- bit 15,13 **UTXISEL[1:0]:** UARTx Transmission Interrupt Mode Selection bits
 11 = Reserved; do not use
 10 = Interrupt when a character is transferred to the Transmit Shift Register (TSR), and as a result, the transmit buffer becomes empty
 01 = Interrupt when the last character is shifted out of the Transmit Shift Register; all transmit operations are completed
 00 = Interrupt when a character is transferred to the Transmit Shift Register (this implies there is at least one character open in the transmit buffer)
- bit 14 **UTXINV:** UARTx IrDA[®] Encoder Transmit Polarity Inversion bit⁽¹⁾
IREN = 0:
 1 = UxTX Idle state is '0'
 0 = UxTX Idle state is '1'
IREN = 1:
 1 = UxTX Idle state is '1'
 0 = UxTX Idle state is '0'
- bit 12 **URXEN:** UARTx Receive Enable bit
 1 = Receive is enabled, UxRX pin is controlled by UARTx
 0 = Receive is disabled, UxRX pin is controlled by the port
- bit 11 **UTXBRK:** UARTx Transmit Break bit
 1 = Sends Sync Break on next transmission – Start bit, followed by twelve '0' bits, followed by Stop bit; cleared by hardware upon completion
 0 = Sync Break transmission is disabled or completed
- bit 10 **UTXEN:** UARTx Transmit Enable bit⁽²⁾
 1 = Transmit is enabled, UxTX pin is controlled by UARTx
 0 = Transmit is disabled, any pending transmission is aborted and the buffer is reset; UxTX pin is controlled by the port
- bit 9 **UTXBF:** UARTx Transmit Buffer Full Status bit (read-only)
 1 = Transmit buffer is full
 0 = Transmit buffer is not full, at least one more character can be written
- bit 8 **TRMT:** Transmit Shift Register Empty bit (read-only)
 1 = Transmit Shift Register is empty and transmit buffer is empty (the last transmission has completed)
 0 = Transmit Shift Register is not empty, a transmission is in progress or queued

Note 1: The value of this bit only affects the transmit properties of the module when the IrDA[®] encoder is enabled (IREN = 1).

2: If UARTEEN = 1, the peripheral inputs and outputs must be configured to an available RPN/RPIn pin. For more information, see [Section 11.5 “Peripheral Pin Select \(PPS\)”](#).

PIC24FJ256GA705 FAMILY

REGISTER 19-2: UxSTA: UARTx STATUS AND CONTROL REGISTER (CONTINUED)

- bit 7-6 **URXISEL[1:0]:** UARTx Receive Interrupt Mode Selection bits
11 = Interrupt is set on an RSR transfer, making the receive buffer full (i.e., has four data characters)
10 = Interrupt is set on an RSR transfer, making the receive buffer 3/4 full (i.e., has three data characters)
0x = Interrupt is set when any character is received and transferred from the RSR to the receive buffer;
 receive buffer has one or more characters
- bit 5 **ADDEN:** Address Character Detect bit (bit 8 of received data = 1)
1 = Address Detect mode is enabled (if 9-bit mode is not selected, this does not take effect)
0 = Address Detect mode is disabled
- bit 4 **RIDLE:** Receiver Idle bit (read-only)
1 = Receiver is Idle
0 = Receiver is active
- bit 3 **PERR:** Parity Error Status bit (read-only)
1 = Parity error has been detected for the current character (the character at the top of the receive FIFO)
0 = Parity error has not been detected
- bit 2 **FERR:** Framing Error Status bit (read-only)
1 = Framing error has been detected for the current character (the character at the top of the receive FIFO)
0 = Framing error has not been detected
- bit 1 **OERR:** Receive Buffer Overrun Error Status bit (clear/read-only)
1 = Receive buffer has overflowed
0 = Receive buffer has not overflowed (clearing a previously set OERR bit ('1'-to-'0' transition) will
 reset the receive buffer and the RSR to the Empty state)
- bit 0 **URXDA:** UARTx Receive Buffer Data Available bit (read-only)
1 = Receive buffer has data, at least one more character can be read
0 = Receive buffer is empty

- Note 1:** The value of this bit only affects the transmit properties of the module when the IrDA[®] encoder is enabled (IREN = 1).
- 2:** If UARTEN = 1, the peripheral inputs and outputs must be configured to an available RPn/RPIn pin. For more information, see [Section 11.5 “Peripheral Pin Select \(PPS\)”](#).

PIC24FJ256GA705 FAMILY

REGISTER 19-3: UxRXREG: UARTx RECEIVE REGISTER (NORMALLY READ-ONLY)

U-0	U-0	U-0	U-0	U-0	U-0	U-0	R-0
—	—	—	—	—	—	—	UxRXREG8
bit 15							bit 8

R-0	R-0	R-0	R-0	R-0	R-0	R-0	R-0
UxRXREG[7:0]							
bit 7							bit 0

Legend:

R = Readable bit W = Writable bit U = Unimplemented bit, read as '0'
 -n = Value at POR '1' = Bit is set '0' = Bit is cleared x = Bit is unknown

bit 15-9 **Unimplemented:** Read as '0'
 bit 8-0 **UxRXREG[8:0]:** Data of the Received Character bits

REGISTER 19-4: UxTXREG: UARTx TRANSMIT REGISTER (NORMALLY WRITE-ONLY)

U-0	U-0	U-0	U-0	U-0	U-0	U-0	W-x
—	—	—	—	—	—	—	UxTXREG8
bit 15							bit 8

W-x	W-x	W-x	W-x	W-x	W-x	W-x	W-x
UxTXREG[7:0]							
bit 7							bit 0

Legend:

R = Readable bit W = Writable bit U = Unimplemented bit, read as '0'
 -n = Value at POR '1' = Bit is set '0' = Bit is cleared x = Bit is unknown

bit 15-9 **Unimplemented:** Read as '0'
 bit 8-0 **UxTXREG[8:0]:** Data of the Transmitted Character bits

PIC24FJ256GA705 FAMILY

REGISTER 19-5: UxBRG: UARTx BAUD RATE GENERATOR REGISTER

R/W-0	R/W-0	R/W-0	R/W-0	R/W-0	R/W-0	R/W-0	R/W-0
BRG[15:8]							
bit 15				bit 8			

R/W-0	R/W-0	R/W-0	R/W-0	R/W-0	R/W-0	R/W-0	R/W-0
BRG[7:0]							
bit 7				bit 0			

Legend:

R = Readable bit W = Writable bit U = Unimplemented bit, read as '0'
 -n = Value at POR '1' = Bit is set '0' = Bit is cleared x = Bit is unknown

bit 15-0 **BRG[15:0]:** Baud Rate Divisor bits

REGISTER 19-6: UxADMD: UARTx ADDRESS DETECT AND MATCH REGISTER

R/W-0	R/W-0	R/W-0	R/W-0	R/W-0	R/W-0	R/W-0	R/W-0
ADMMASK[7:0]							
bit 15				bit 8			

R/W-0	R/W-0	R/W-0	R/W-0	R/W-0	R/W-0	R/W-0	R/W-0
ADMADDR[7:0]							
bit 7				bit 0			

Legend:

R = Readable bit W = Writable bit U = Unimplemented bit, read as '0'
 -n = Value at POR '1' = Bit is set '0' = Bit is cleared x = Bit is unknown

bit 15-8 **ADMMASK[7:0]:** ADMADDR[7:0] (UxADMD[7:0]) Masking bits

For ADMMASKx:

1 = ADMADDRx is used to detect the address match
 0 = ADMADDRx is not used to detect the address match

bit 7-0 **ADMADDR[7:0]:** Address Detect Task Off-Load bits

Used with the ADMMASK[7:0] bits (UxADMD[15:8]) to off-load the task of detecting the address character from the processor during Address Detect mode.

20.0 ENHANCED PARALLEL MASTER PORT (EPMP)

Note: This data sheet summarizes the features of this group of PIC24F devices. It is not intended to be a comprehensive reference source. For more information, refer to “**Enhanced Parallel Master Port (EPMP)**” (www.microchip.com/DS39730) in the “*dsPIC33/PIC24 Family Reference Manual*”. The information in this data sheet supersedes the information in the FRM.

The Enhanced Parallel Master Port (EPMP) module provides a parallel, 4-bit (Master mode only) or 8-bit (Master and Slave modes) data bus interface to communicate with off-chip modules, such as memories, FIFOs, LCD Controllers and other microcontrollers. This module can serve as either the Master or the Slave on the communication bus.

For EPMP Master modes, all external addresses are mapped into the internal Extended Data Space (EDS). This is done by allocating a region of the EDS for each Chip Select, and then assigning each Chip Select to a particular external resource, such as a memory or external controller. This region should not be assigned to another device resource, such as RAM or SFRs. To perform a write or read on an external resource, the CPU simply performs a write or read within the address range assigned for the EPMP.

Key features of the EPMP module are:

- Extended Data Space (EDS) Interface Allows Direct Access from the CPU
- Up to Ten Programmable Address Lines
- Up to Two Chip Select Lines
- Up to Two Acknowledgment Lines (one per Chip Select)
- 4-Bit or 8-Bit Wide Data Bus
- Programmable Strobe Options (per Chip Select):
 - Individual read and write strobes or;
 - Read/ $\overline{\text{Write}}$ strobe with enable strobe
- Programmable Address/Data Multiplexing
- Programmable Address Wait States
- Programmable Data Wait States (per Chip Select)
- Programmable Polarity on Control Signals (per Chip Select)
- Legacy Parallel Slave Port Support
- Enhanced Parallel Slave Support:
 - Address support
 - 4-byte deep auto-incrementing buffer

Only the higher pin count packages in the family implement the EPMP. The EPMP feature is not available on 28-pin devices.

PIC24FJ256GA705 FAMILY

20.1 Memory Addressable in Different Modes

The memory space addressable by the device depends on the address/data multiplexing selection; it varies from 1K to 2 MB. Refer to [Table 20-1](#) for different Memory-Addressable modes.

20.2 PMDOUT1 and PMDOUT2 Registers

The EPMP Data Output 1 and Data Output 2 registers are used only in Slave mode. These registers act as a buffer for outgoing data.

20.3 PMDIN1 and PMDIN2 Registers

The EPMP Data Input 1 and Data Input 2 registers are used in Slave modes to buffer incoming data. These registers hold data that are asynchronously clocked in. In Master mode, PMDIN1 is the holding register for incoming data.

TABLE 20-1: EPMP FEATURE DIFFERENCES BY DEVICE PIN COUNT

Data Port Size	PMA[9:8]	PMA[7:0]	PMD[7:4]	PMD[3:0]	Accessible Memory
Demultiplexed Address (ADRMUX[1:0] = 00)					
8-Bit (PTSZ[1:0] = 00)	Addr[9:8]	Addr[7:0]	Data		1K
4-Bit (PTSZ[1:0] = 01)	Addr[9:8]	Addr[7:0]	—	Data	1K
1 Address Phase (ADRMUX[1:0] = 01)					
8-Bit (PTSZ[1:0] = 00)	—	PMALL	Addr[7:0] Data		1K
4-Bit (PTSZ[1:0] = 01)	Addr[9:8]	PMALL	Addr[7:4]	Addr[3:0]	1K
			—	Data (1)	
2 Address Phases (ADRMUX[1:0] = 10)					
8-Bit (PTSZ[1:0] = 00)	—	PMALL	Addr[7:0]		64K
		PMALH	Addr[15:8]		
		—	Data		
4-Bit (PTSZ[1:0] = 01)	Addr[9:8]	PMALL	Addr[3:0]		1K
		PMALH	Addr[7:4]		
		—	Data		
3 Address Phases (ADRMUX[1:0] = 11)					
8-Bit (PTSZ[1:0] = 00)	—	PMALL	Addr[7:0]		2 Mbytes
		PMALH	Addr[15:8]		
		PMALU	Addr[22:16]		
		—	Data		
4-Bit (PTSZ[1:0] = 01)	Addr[13:12]	PMALL	Addr[3:0]		16K
		PMALH	Addr[7:4]		
		PMALU	Addr[11:8]		
		—	Data		

PIC24FJ256GA705 FAMILY

TABLE 20-2: ENHANCED PARALLEL MASTER PORT PIN DESCRIPTIONS

Pin Name (Alternate Function)	Type	Description
PMA[22:16]	O	Address Bus bits[22:16]
PMA14 (PMCS1)	O	Address Bus bit 14
	I/O	Data Bus bit 14 (16-bit port with Multiplexed Addressing)
	O	Chip Select 1 (alternate location)
PMA[13:8]	O	Address Bus bits[13:8]
	I/O	Data Bus bits[13:8] (16-bit port with Multiplexed Addressing)
PMA[7:3]	O	Address Bus bits[7:3]
PMA2 (PMALU)	O	Address Bus bit 2
	O	Address Latch Upper Strobe for Multiplexed Address
PMA1 (PMALH)	I/O	Address Bus bit 1
	O	Address Latch High Strobe for Multiplexed Address
PMA0 (PMALL)	I/O	Address Bus bit 0
	O	Address Latch Low Strobe for Multiplexed Address
PMD[15:8]	I/O	Data Bus bits[15:8] (Demultiplexed Addressing)
PMD[7:4]	I/O	Data Bus bits[7:4]
	O	Address Bus bits[7:4] (4-bit port with 1-Phase Multiplexed Addressing)
PMD[3:0]	I/O	Data Bus bits[3:0]
PMCS1	O	Chip Select 1
PMCS2	O	Chip Select 2
PMWR	I/O	Write Strobe ⁽¹⁾
(PMENB)	I/O	Enable Signal ⁽¹⁾
PMRD	I/O	Read Strobe ⁽¹⁾
(PMRD/PMWR)	I/O	Read/Write Signal ⁽¹⁾
PMBE1	O	Byte Indicator
PMBE0	O	Nibble or Byte Indicator
PMACK1	I	Acknowledgment Signal 1
PMACK2	I	Acknowledgment Signal 2

Note 1: Signal function depends on the setting of the MODE[1:0] and SM bits (PMCON1[9:8] and PMCSxCF[8]).

PIC24FJ256GA705 FAMILY

REGISTER 20-1: PMCON1: EPMP CONTROL REGISTER 1

R/W-0	U-0	R/W-0	R/W-0	R/W-0	U-0	R/W-0	R/W-0
PMPEN	—	PSIDL	ADRMUX1	ADRMUX0	—	MODE1	MODE0
bit 15							bit 8

R/W-0	R/W-0	R/W-0	R/W-0	U-0	R/W-0	R/W-0	R/W-0
CSF1	CSF0	ALP	ALMODE	—	BUSKEEP	IRQM1	IRQM0
bit 7							bit 0

Legend:

R = Readable bit W = Writable bit U = Unimplemented bit, read as '0'
 -n = Value at POR '1' = Bit is set '0' = Bit is cleared x = Bit is unknown

- bit 15 **PMPEN:** Parallel Master Port Enable bit
 1 = EPMP is enabled
 0 = EPMP is disabled
- bit 14 **Unimplemented:** Read as '0'
- bit 13 **PSIDL:** Parallel Master Port Stop in Idle Mode bit
 1 = Discontinues module operation when device enters Idle mode
 0 = Continues module operation in Idle mode
- bit 12-11 **ADRMUX[1:0]:** Address/Data Multiplexing Selection bits
 11 = Lower address bits are multiplexed with data bits using three address phases
 10 = Lower address bits are multiplexed with data bits using two address phases
 01 = Lower address bits are multiplexed with data bits using one address phase
 00 = Address and data appear on separate pins
- bit 10 **Unimplemented:** Read as '0'
- bit 9-8 **MODE[1:0]:** Parallel Port Mode Select bits
 11 = Master mode
 10 = Enhanced PSP; pins used are PMRD, PMWR, PMCS, PMD[7:0] and PMA[1:0]
 01 = Buffered PSP; pins used are PMRD, PMWR, PMCS and PMD[7:0]
 00 = Legacy Parallel Slave Port; pins used are PMRD, PMWR, PMCS and PMD[7:0]
- bit 7-6 **CSF[1:0]:** Chip Select Function bits
 11 = Reserved
 10 = PMA14 is used for Chip Select 1
 01 = Reserved
 00 = PMCS2 is used for Chip Select 2, PMCS1 is used for Chip Select 1
- bit 5 **ALP:** Address Latch Polarity bit
 1 = Active-high (PMALL, PMALH and PMALU)
 0 = Active-low (PMALL, PMALH and PMALU)
- bit 4 **ALMODE:** Address Latch Strobe Mode bit
 1 = Enables "smart" address strobes (each address phase is only present if the current access would cause a different address in the latch than the previous address)
 0 = Disables "smart" address strobes
- bit 3 **Unimplemented:** Read as '0'
- bit 2 **BUSKEEP:** Bus Keeper bit
 1 = Data bus keeps its last value when not actively being driven
 0 = Data bus is in a High-Impedance state when not actively being driven
- bit 1-0 **IRQM[1:0]:** Interrupt Request Mode bits
 11 = Interrupt is generated when Read Buffer 3 is read or Write Buffer 3 is written (Buffered PSP mode), or on a read or write operation when PMA[1:0] = 11 (Addressable PSP mode only)
 10 = Reserved
 01 = Interrupt is generated at the end of a read/write cycle
 00 = No interrupt is generated

PIC24FJ256GA705 FAMILY

REGISTER 20-2: PMCON2: EPMP CONTROL REGISTER 2

HSC/R-0	U-0	HS/R/C-0	HS/R/C-0	U-0	U-0	U-0	U-0
BUSY	—	ERROR	TIMEOUT	—	—	—	—
bit 15							bit 8

R/W-0	R/W-0	R/W-0	R/W-0	R/W-0	R/W-0	R/W-0	R/W-0
RADDR[23:16] ⁽¹⁾							
bit 7							bit 0

Legend:		
R = Readable bit	W = Writable bit	U = Unimplemented, read as '0'
-n = Value at POR	'1' = Bit is set	'0' = Bit is cleared
C = Clearable bit	HS = Hardware Settable bit	x = Bit is unknown
	HSC = Hardware Settable/Clearable bit	

- bit 15 **BUSY:** Busy bit (Master mode only)
 - 1 = Port is busy
 - 0 = Port is not busy
- bit 14 **Unimplemented:** Read as '0'
- bit 13 **ERROR:** Error bit
 - 1 = Transaction error (illegal transaction was requested)
 - 0 = Transaction completed successfully
- bit 12 **TIMEOUT:** Time-out bit
 - 1 = Transaction timed out
 - 0 = Transaction completed successfully
- bit 11-8 **Unimplemented:** Read as '0'
- bit 7-0 **RADDR[23:16]:** Parallel Master Port Reserved Address Space bits⁽¹⁾

Note 1: If RADDR[23:16] = 00000000, then the last EDS address for Chip Select 2 will be FFFFFFFh.

PIC24FJ256GA705 FAMILY

REGISTER 20-3: PMCON3: EPMP CONTROL REGISTER 3

R/W-0	R/W-0	R/W-0	R/W-0	U-0	R/W-0	R/W-0	R/W-0
PTWREN	PTRDEN	PTBE1EN	PTBE0EN	—	AWAITM1	AWAITM0	AWAITE
bit 15							bit 8

U-0	U-0	U-0	U-0	U-0	U-0	U-0	U-0
—	—	—	—	—	—	—	—
bit 7							bit 0

Legend:

R = Readable bit W = Writable bit U = Unimplemented bit, read as '0'
 -n = Value at POR '1' = Bit is set '0' = Bit is cleared x = Bit is unknown

- bit 15 **PTWREN:** Write/Enable Strobe Port Enable bit
 1 = PMWR/PMENB port is enabled
 0 = PMWR/PMENB port is disabled
- bit 14 **PTRDEN:** Read/Write Strobe Port Enable bit
 1 = PMRD/PMWR port is enabled
 0 = PMRD/PMWR port is disabled
- bit 13 **PTBE1EN:** High Nibble/Byte Enable Port Enable bit
 1 = PMBE1 port is enabled
 0 = PMBE1 port is disabled
- bit 12 **PTBE0EN:** Low Nibble/Byte Enable Port Enable bit
 1 = PMBE0 port is enabled
 0 = PMBE0 port is disabled
- bit 11 **Unimplemented:** Read as '0'
- bit 10-9 **AWAITM[1:0]:** Address Latch Strobe Wait State bits
 11 = Wait of 3½ TcY
 10 = Wait of 2½ TcY
 01 = Wait of 1½ TcY
 00 = Wait of ½ TcY
- bit 8 **AWAITE:** Address Hold After Address Latch Strobe Wait State bits
 1 = Wait of 1¼ TcY
 0 = Wait of ¼ TcY
- bit 7-0 **Unimplemented:** Read as '0'

PIC24FJ256GA705 FAMILY

REGISTER 20-4: PMCON4: EPMP CONTROL REGISTER 4

U-0	R/W-0	R/W-0	R/W-0	R/W-0	R/W-0	R/W-0	R/W-0	
—	PTEN14	PTEN[13:8]						
bit 15								bit 8

R/W-0	R/W-0	R/W-0	R/W-0	R/W-0	R/W-0	R/W-0	R/W-0	
PTEN[7:3]				PTEN[2:0]				
bit 7								bit 0

Legend:

R = Readable bit	W = Writable bit	U = Unimplemented bit, read as '0'
-n = Value at POR	'1' = Bit is set	'0' = Bit is cleared x = Bit is unknown

- bit 15 **Unimplemented:** Read as '0'
- bit 14 **PTEN14:** PMA14 Port Enable bit
 - 1 = PMA14 functions as either Address Line 14 or Chip Select 1
 - 0 = PMA14 functions as port I/O
- bit 13-3 **PTEN[13:3]:** EPMP Address Port Enable bits
 - 1 = PMA[13:3] function as EPMP address lines
 - 0 = PMA[13:3] function as port I/Os
- bit 2-0 **PTEN[2:0]:** PMALU/PMALH/PMALL Strobe Enable bits
 - 1 = PMA[2:0] function as either address lines or address latch strobes
 - 0 = PMA[2:0] function as port I/Os

PIC24FJ256GA705 FAMILY

REGISTER 20-5: PMCSxCF: EPMP CHIP SELECT x CONFIGURATION REGISTER

R/W-0	R/W-0	R/W-0	R/W-0	U-0	R/W-0	R/W-0	R/W-0
CSDIS	CSP	CSPTEN	BEP	—	WRSP	RDSP	SM
bit 15						bit 8	

R/W-0	R/W-0	R/W-0	U-0	U-0	U-0	U-0	U-0
ACKP	PTSZ1	PTSZ0	—	—	—	—	—
bit 7						bit 0	

Legend:

R = Readable bit	W = Writable bit	U = Unimplemented bit, read as '0'
-n = Value at POR	'1' = Bit is set	'0' = Bit is cleared
		x = Bit is unknown

- bit 15 **CSDIS:** Chip Select x Disable bit
 1 = Disables the Chip Select x functionality
 0 = Enables the Chip Select x functionality
- bit 14 **CSP:** Chip Select x Polarity bit
 1 = Active-high (PMCSx)
 0 = Active-low ($\overline{\text{PMCSx}}$)
- bit 13 **CSPTEN:** PMCSx Port Enable bit
 1 = PMCSx port is enabled
 0 = PMCSx port is disabled
- bit 12 **BEP:** Chip Select x Nibble/Byte Enable Polarity bit
 1 = Nibble/byte enable is active-high (PMBE0, PMBE1)
 0 = Nibble/byte enable is active-low ($\overline{\text{PMBE0}}$, $\overline{\text{PMBE1}}$)
- bit 11 **Unimplemented:** Read as '0'
- bit 10 **WRSP:** Chip Select x Write Strobe Polarity bit
For Slave modes and Master mode when SM = 0:
 1 = Write strobe is active-high (PMWR)
 0 = Write strobe is active-low ($\overline{\text{PMWR}}$)
For Master mode when SM = 1:
 1 = Enable strobe is active-high (PMENB)
 0 = Enable strobe is active-low ($\overline{\text{PMENB}}$)
- bit 9 **RDSP:** Chip Select x Read Strobe Polarity bit
For Slave modes and Master mode when SM = 0:
 1 = Read strobe is active-high (PMRD)
 0 = Read strobe is active-low ($\overline{\text{PMRD}}$)
For Master mode when SM = 1:
 1 = Read/write strobe is active-high (PMRD/ $\overline{\text{PMWR}}$)
 0 = Read/write strobe is active-low ($\overline{\text{PMRD}}$ / $\overline{\text{PMWR}}$)
- bit 8 **SM:** Chip Select x Strobe Mode bit
 1 = Reads/writes and enables strobes (PMRD/ $\overline{\text{PMWR}}$ and PMENB)
 0 = Reads and writes strobes (PMRD and PMWR)
- bit 7 **ACKP:** Chip Select x Acknowledge Polarity bit
 1 = ACK is active-high (PMACK1)
 0 = ACK is active-low ($\overline{\text{PMACK1}}$)
- bit 6-5 **PTSZ[1:0]:** Chip Select x Port Size bits
 11 = Reserved
 10 = Reserved
 01 = 4-bit port size (PMD[3:0])
 00 = 8-bit port size (PMD[7:0])
- bit 4-0 **Unimplemented:** Read as '0'

PIC24FJ256GA705 FAMILY

REGISTER 20-6: PMCSxBS: EPMP CHIP SELECT x BASE ADDRESS REGISTER⁽²⁾

R/W ⁽¹⁾	R/W ⁽¹⁾	R/W ⁽¹⁾	R/W ⁽¹⁾	R/W ⁽¹⁾	R/W ⁽¹⁾	R/W ⁽¹⁾	R/W ⁽¹⁾
BASE[23:16]							
bit 15							bit 8

R/W ⁽¹⁾	U-0	U-0	U-0	R/W ⁽¹⁾	U-0	U-0	U-0
BASE15	—	—	—	BASE11	—	—	—
bit 7							bit 0

Legend:

R = Readable bit	W = Writable bit	U = Unimplemented bit, read as '0'
-n = Value at POR	'1' = Bit is set	'0' = Bit is cleared
		x = Bit is unknown

- bit 15-7 **BASE[23:15]:** Chip Select x Base Address bits⁽¹⁾
- bit 6-4 **Unimplemented:** Read as '0'
- bit 3 **BASE11:** Chip Select x Base Address bit⁽¹⁾
- bit 2-0 **Unimplemented:** Read as '0'

Note 1: The value at POR is 0080h for PMCS1BS and 8080h for PMCS2BS.

- 2:** If the whole PMCS2BS register is written together as 0x0000, then the last EDS address for the Chip Select 1 will be FFFFFFFh. In this case, Chip Select 2 should not be used. PMCS1BS has no such feature.

PIC24FJ256GA705 FAMILY

REGISTER 20-7: PMCSxMD: EPMP CHIP SELECT x MODE REGISTER

R/W-0	R/W-0	R/W-0	R/W-0	R/W-0	U-0	U-0	U-0
ACKM1	ACKM0	AMWAIT2	AMWAIT1	AMWAIT0	—	—	—
bit 15							bit 8

R/W-0	R/W-0	R/W-0	R/W-0	R/W-0	R/W-0	R/W-0	R/W-0
DWAITB1	DWAITB0	DWAITM3	DWAITM2	DWAITM1	DWAITM0	DWAITE1	DWAITE0
bit 7							bit 0

Legend:

R = Readable bit W = Writable bit U = Unimplemented bit, read as '0'
 -n = Value at POR '1' = Bit is set '0' = Bit is cleared x = Bit is unknown

bit 15-14 **ACKM[1:0]:** Chip Select x Acknowledge Mode bits
 11 = Reserved
 10 = PMACKx is used to determine when a read/write operation is complete
 01 = PMACKx is used to determine when a read/write operation is complete with time-out
 (if DWAITM[3:0] = 0000, the maximum time-out is 255 Tcy or else it is DWAITM[3:0] cycles.)
 00 = PMACKx is not used

bit 13-11 **AMWAIT[2:0]:** Chip Select x Alternate Master Wait State bits
 111 = Wait of ten alternate Master cycles
 ...
 001 = Wait of four alternate Master cycles
 000 = Wait of three alternate Master cycles

bit 10-8 **Unimplemented:** Read as '0'

bit 7-6 **DWAITB[1:0]:** Chip Select x Data Setup Before Read/Write Strobe Wait State bits
 11 = Wait of 3¼ Tcy
 10 = Wait of 2¼ Tcy
 01 = Wait of 1¼ Tcy
 00 = Wait of ¼ Tcy

bit 5-2 **DWAITM[3:0]:** Chip Select x Data Read/Write Strobe Wait State bits
For Write Operations:
 1111 = Wait of 15½ Tcy
 ...
 0001 = Wait of 1½ Tcy
 0000 = Wait of ½ Tcy
For Read Operations:
 1111 = Wait of 15¾ Tcy
 ...
 0001 = Wait of 1¾ Tcy
 0000 = Wait of ¾ Tcy

bit 1-0 **DWAITE[1:0]:** Chip Select x Data Hold After Read/Write Strobe Wait State bits
For Write Operations:
 11 = Wait of 3¼ Tcy
 10 = Wait of 2¼ Tcy
 01 = Wait of 1¼ Tcy
 00 = Wait of ¼ Tcy
For Read Operations:
 11 = Wait of 3 Tcy
 10 = Wait of 2 Tcy
 01 = Wait of 1 Tcy
 00 = Wait of 0 Tcy

PIC24FJ256GA705 FAMILY

REGISTER 20-8: PMSTAT: EPMP STATUS REGISTER (SLAVE MODE ONLY)

HSC/R-0	HS/R/W-0	U-0	U-0	HSC/R-0	HSC/R-0	HSC/R-0	HSC/R-0
IBF	IBOV	—	—	IB3F ⁽¹⁾	IB2F ⁽¹⁾	IB1F ⁽¹⁾	IB0F ⁽¹⁾
bit 15							bit 8

HSC/R-1	HS/R/W-0	U-0	U-0	HSC/R-1	HSC/R-1	HSC/R-1	HSC/R-1
OBE	OBUF	—	—	OB3E	OB2E	OB1E	OB0E
bit 7							bit 0

Legend:	HS = Hardware Settable bit	HSC = Hardware Settable/Clearable bit
R = Readable bit	W = Writable bit	U = Unimplemented bit, read as '0'
-n = Value at POR	'1' = Bit is set	'0' = Bit is cleared
		x = Bit is unknown

- bit 15 **IBF:** Input Buffer Full Status bit
 1 = All writable Input Buffer registers are full
 0 = Some or all of the writable Input Buffer registers are empty
- bit 14 **IBOV:** Input Buffer Overflow Status bit
 1 = A write attempt to a full Input register occurred (must be cleared in software)
 0 = No overflow occurred
- bit 13-12 **Unimplemented:** Read as '0'
- bit 11-8 **IB3F:IB0F:** Input Buffer x Status Full bits⁽¹⁾
 1 = Input buffer contains unread data (reading the buffer will clear this bit)
 0 = Input buffer does not contain unread data
- bit 7 **OBE:** Output Buffer Empty Status bit
 1 = All readable Output Buffer registers are empty
 0 = Some or all of the readable Output Buffer registers are full
- bit 6 **OBUF:** Output Buffer Underflow Status bit
 1 = A read occurred from an empty Output Buffer register (must be cleared in software)
 0 = No underflow occurred
- bit 5-4 **Unimplemented:** Read as '0'
- bit 3-0 **OB3E:OB0E:** Output Buffer x Status Empty bits
 1 = Output Buffer x is empty (writing data to the buffer will clear this bit)
 0 = Output Buffer x contains untransmitted data

Note 1: Even though an individual bit represents the byte in the buffer, the bits corresponding to the word (Byte 0 and 1 or Byte 2 and 3) get cleared, even on byte reading.

PIC24FJ256GA705 FAMILY

REGISTER 20-9: PADCON: PAD CONFIGURATION CONTROL REGISTER

R/W-0	U-0	U-0	U-0	U-0	U-0	U-0	U-0
IOCON	—	—	—	—	—	—	—
bit 15							bit 8

U-0	U-0	U-0	U-0	U-0	U-0	U-0	R/W-0
—	—	—	—	—	—	—	PMPTTL
bit 7							bit 0

Legend:

R = Readable bit W = Writable bit U = Unimplemented bit, read as '0'
 -n = Value at POR '1' = Bit is set '0' = Bit is cleared x = Bit is unknown

- bit 15 **IOCON:** Used for Non-PMP functionality
- bit 14-1 **Unimplemented:** Read as '0'
- bit 0 **PMPTTL:** EPMP Module TTL Input Buffer Select bit
 - 1 = EPMP module inputs (PMDx, PMCS1) use TTL input buffers
 - 0 = EPMP module inputs use Schmitt Trigger input buffers

21.0 REAL-TIME CLOCK AND CALENDAR (RTCC) WITH TIMESTAMP

Note: This data sheet summarizes the features of this group of PIC24F devices. It is not intended to be a comprehensive reference source. For more information on the Real-Time Clock and Calendar, refer to “RTCC with Timestamp” (www.microchip.com/DS70005193) in the “dsPIC33/PIC24 Family Reference Manual”. The information in this data sheet supersedes the information in the FRM.

The RTCC provides the user with a Real-Time Clock and Calendar (RTCC) function that can be calibrated.

Key features of the RTCC module are:

- Selectable Clock Source
- Provides Hours, Minutes and Seconds Using 24-Hour Format
- Visibility of One Half Second Period
- Provides Calendar – Weekday, Date, Month and Year
- Alarm-Configurable for Half a Second, 1 Second, 10 Seconds, 1 Minute, 10 Minutes, 1 Hour, 1 Day, 1 Week, 1 Month or 1 Year
- Alarm Repeat with Decrementing Counter
- Alarm with Indefinite Repeat Chime
- Year 2000 to 2099 Leap Year Correction
- BCD Format for Smaller Software Overhead
- Optimized for Long-Term Battery Operation
- User Calibration of the 32.768 kHz Clock Crystal/32 kHz INTRC Frequency with Periodic Auto-Adjust
- Fractional Second Synchronization
- Calibration to within ±2.64 Seconds Error per Month
- Calibrates up to 260 ppm of Crystal Error
- Ability to Periodically Wake-up External Devices without CPU Intervention (external power control)
- Power Control Output for External Circuit Control
- Calibration takes Effect Every 15 Seconds
- Timestamp Capture register for Time and Date
- Programmable Prescaler and Clock Divider Circuit allows Operation with Any Clock Source up to 32 MHz, Including 32.768 kHz Crystal, 50/60 Hz Powerline Clock, External Real-Time Clock (RTC) or 31.25 kHz LPRC Clock

21.1 RTCC Source Clock

The RTCC clock divider block converts the incoming oscillator source into accurate 1/2 and 1 second clocks for the RTCC. The clock divider is optimized to work with three different oscillator sources:

- 32.768 kHz crystal oscillator
- 31 kHz Low-Power RC Oscillator (LPRC)
- External 50 Hz or 60 Hz powerline frequency

An asynchronous prescaler, PS[1:0] (RTCCON2L[5:4]), is provided that allows the RTCC to work with higher speed clock sources, such as the system clock. Divide ratios of 1:16, 1:64 or 1:256 may be selected, allowing sources up to 32 MHz to clock the RTCC.

21.1.1 COARSE FREQUENCY DIVISION

The clock divider block has a 16-bit counter used to divide the input clock frequency. The divide ratio is set by the DIV[15:0] register bits (RTCCON2H[15:0]). The DIV[15:0] bits should be programmed with a value to produce a nominal 1/2 second clock divider count period.

21.1.2 FINE FREQUENCY DIVISION

The fine frequency division is set using the FDIV[4:0] (RTCCON2L[15:11]) bits. Increasing the FDIVx value will lengthen the overall clock divider period.

If FDIV[4:0] = 00000, the fine frequency division circuit is effectively disabled. Otherwise, it will optionally remove a clock pulse from the input of the clock divider every 1/2 second. This functionality will allow the user to remove up to 31 pulses over a fixed period of 16 seconds, depending on the value of FDIVx.

The value for DIV[15:0] is calculated as shown in Equation 21-1. The fractional remainder of the DIV[15:0] calculation result can be used to calculate the value for FDIV[4:0].

EQUATION 21-1: RTCC CLOCK DIVIDER OUTPUT FREQUENCY

$$F_{OUT} = \frac{F_{IN}}{2 \cdot (PS[1:0] \text{ Prescaler}) \cdot (DIV[15:0] + 1) + \left(\frac{FDIV[4:0]}{32} \right)}$$

The DIV[15:0] value is the integer part of this calculation:

$$DIV[15:0] = \frac{F_{IN}}{2 \cdot (PS[1:0] \text{ Prescaler})} - 1$$

The FDIV[4:0] value is the fractional part of the DIV[15:0] calculation, multiplied by 32.

PIC24FJ256GA705 FAMILY

FIGURE 21-1: RTCC BLOCK DIAGRAM

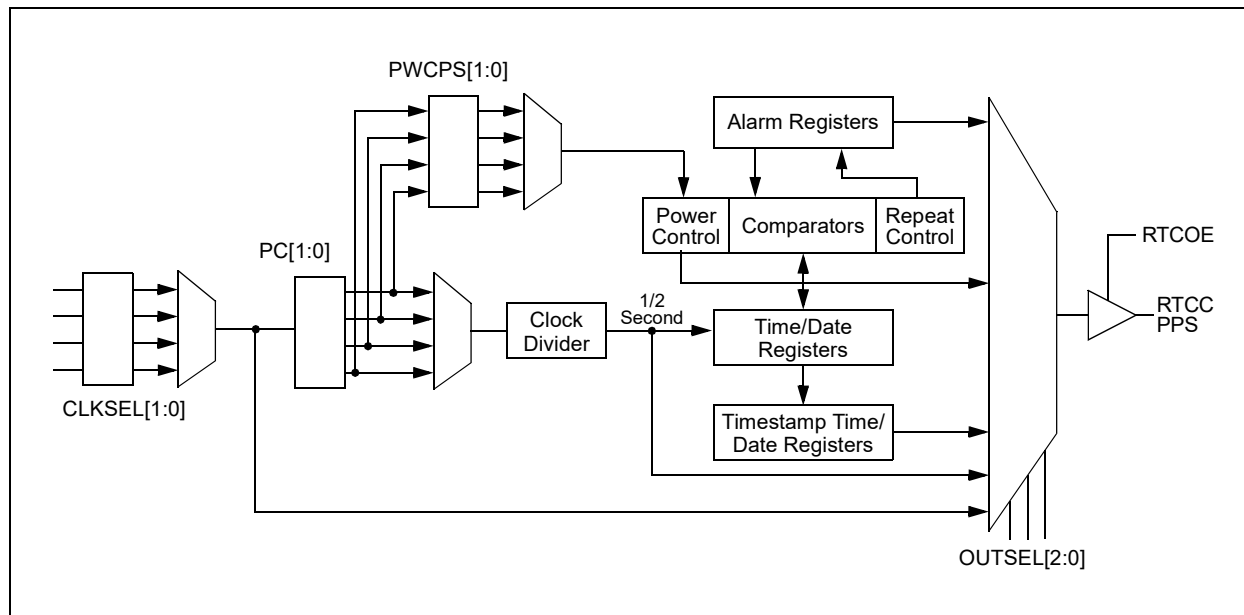

21.2 RTCC Module Registers

The RTCC module registers are organized into four categories:

- RTCC Control Registers
- RTCC Value Registers
- Alarm Value Registers
- Timestamp Registers

21.2.1 REGISTER MAPPING

Previous RTCC implementations used a Register Pointer to access the RTCC Time and Date registers, as well as the Alarm Time and Date registers. These Registers are now mapped to memory and are individually addressable.

21.2.2 WRITE LOCK

To prevent spurious changes to the Time Control or Time Value registers, the WRLOCK bit (RTCCON1L[11]) must be cleared ('0'). The POR Default state is when the WRLOCK bit is '0' and is cleared on any device Reset (POR, BOR, MCLR). It is recommended that the WRLOCK bit be set to '1' after the Date and Time registers are properly initialized, and after the RTCEN bit (RTCCON1L[15]) has been set.

Any attempt to write to the RTCEN bit, the RTCCON2L/H registers, or the Date or Time registers, will be ignored as long as WRLOCK is '1'. The Alarm, Power Control and Timestamp registers can be changed when WRLOCK is '1'.

Clearing the WRLOCK bit requires an unlock sequence after it has been written to a '1', writing two bytes consecutively to the NVMKEY register. A sample assembly sequence is shown in [Example 21-1](#). If WRLOCK is already cleared, it can be set to '1' without using the unlock sequence.

Note: To avoid accidental writes to the timer, it is recommended that the WRLOCK bit (RTCCON1L[11]) is kept clear at any other time. For the WRLOCK bit to be set, there is only one instruction cycle time window allowed between the 55h/AA sequence and the setting of WRLOCK; therefore, it is recommended that code follow the procedure in [Example 21-1](#).

21.2.3 SELECTING RTCC CLOCK SOURCE

The clock source for the RTCC module can be selected using the CLKSEL[1:0] bits in the RTCCON2L register. When the bits are set to '00', the Secondary Oscillator (SOSC) is used as the reference clock and when the bits are '01', LPRC is used as the reference clock. When CLKSEL[1:0] = 10, the external powerline (50 Hz and 60 Hz) is used as the clock source. When CLKSEL[1:0] = 11, the system clock is used as the clock source.

EXAMPLE 21-1: SETTING THE WRLOCK BIT

```
DISI    #6                ;disable interrupts for 6 instructions
MOV     #NVMKEY, W1
MOV     #0x55, W2         ; first unlock code
MOV     W2, [W1]         ; write first unlock code
MOV     #0xAA, W3        ; second unlock sequence
MOV     W3, [W1]        ; write second unlock sequence
BCLR    RTCCON1L, #WRLOCK ; clear the WRLOCK bit
```

PIC24FJ256GA705 FAMILY

21.3 Registers

21.3.1 RTCC CONTROL REGISTERS

REGISTER 21-1: RTCCON1L: RTCC CONTROL REGISTER 1 (LOW)

R/W-0	U-0	U-0	U-0	R/W-0	R/W-0	R/W-0	R/W-0
RTCEN	—	—	—	WRLOCK	PWCEN	PWCPOL	PWCPOE
bit 15							bit 8

R/W-0	R/W-0	R/W-0	R/W-0	U-0	U-0	U-0	R/W-0
RTCOE	OUTSEL2	OUTSEL1	OUTSEL0	—	—	—	TSAEN
bit 7							bit 0

Legend:

R = Readable bit

W = Writable bit

U = Unimplemented bit, read as '0'

-n = Value at POR

'1' = Bit is set

'0' = Bit is cleared

x = Bit is unknown

- bit 15 **RTCEN:** RTCC Enable bit
 1 = RTCC is enabled and counts from selected clock source
 0 = RTCC is not enabled
- bit 14-12 **Unimplemented:** Read as '0'
- bit 11 **WRLOCK:** RTCC Register Write Lock
 1 = RTCC registers are locked
 0 = RTCC registers may be written to by user
- bit 10 **PWCEN:** Power Control Enable bit
 1 = Power control is enabled
 0 = Power control is disabled
- bit 9 **PWCPOL:** Power Control Polarity bit
 1 = Power control output is active-high
 0 = Power control output is active-low
- bit 8 **PWCPOE:** Power Control Output Enable bit
 1 = Power control output pin is enabled
 0 = Power control output pin is disabled
- bit 7 **RTCOE:** RTCC Output Enable bit
 1 = RTCC output is enabled
 0 = RTCC output is disabled
- bit 6-4 **OUTSEL[2:0]:** RTCC Output Signal Selection bits
 111 = Unused
 110 = Unused
 101 = Unused
 100 = Timestamp A event
 011 = Power control
 010 = RTCC input clock
 001 = Second clock
 000 = Alarm event
- bit 3-1 **Unimplemented:** Read as '0'
- bit 0 **TSAEN:** Timestamp A Enable bit
 1 = Timestamp event will occur when a low pulse is detected on the $\overline{\text{TMPRN}}$ pin
 0 = Timestamp is disabled

PIC24FJ256GA705 FAMILY

REGISTER 21-2: RTCCON1H: RTCC CONTROL REGISTER 1 (HIGH)

R/W-0	R/W-0	U-0	U-0	R/W-0	R/W-0	R/W-0	R/W-0
ALRMEN	CHIME	—	—	AMASK3	AMASK2	AMASK1	AMASK0
bit 15							bit 8

R/W-0	R/W-0	R/W-0	R/W-0	R/W-0	R/W-0	R/W-0	R/W-0
ALMRPT[7:0]							
bit 7							bit 0

Legend:

R = Readable bit	W = Writable bit	U = Unimplemented bit, read as '0'
-n = Value at POR	'1' = Bit is set	'0' = Bit is cleared x = Bit is unknown

- bit 15 **ALRMEN:** Alarm Enable bit
 1 = Alarm is enabled (cleared automatically after an alarm event whenever ALMRPT[7:0] = 00h and CHIME = 0)
 0 = Alarm is disabled
- bit 14 **CHIME:** Chime Enable bit
 1 = Chime is enabled; ALMRPT[7:0] bits roll over from 00h to FFh
 0 = Chime is disabled; ALMRPT[7:0] bits stop once they reach 00h
- bit 13-12 **Unimplemented:** Read as '0'
- bit 11-8 **AMASK[3:0]:** Alarm Mask Configuration bits
 0000 = Every half second
 0001 = Every second
 0010 = Every ten seconds
 0011 = Every minute
 0100 = Every ten minutes
 0101 = Every hour
 0110 = Once a day
 0111 = Once a week
 1000 = Once a month
 1001 = Once a year (except when configured for February 29th, once every four years)
 101x = Reserved – do not use
 11xx = Reserved – do not use
- bit 7-0 **ALMRPT[7:0]:** Alarm Repeat Counter Value bits
 11111111 = Alarm will repeat 255 more times
 •
 •
 •
 00000000 = Alarm will repeat 0 more times
 The counter decrements on any alarm event. The counter is prevented from rolling over from '00' to 'FF' unless CHIME = 1.

PIC24FJ256GA705 FAMILY

REGISTER 21-3: RTCCON2L: RTCC CONTROL REGISTER 2 (LOW)

R/W-0	R/W-0	R/W-0	R/W-0	R/W-0	U-0	U-0	U-0
FDIV[4:0]					—	—	—
bit 15					bit 8		

R/W-0	R/W-0	R/W-0	R/W-0	U-0	U-0	R/W-0	R/W-0
PWCPS1	PWCPS0	PS1	PS0	—	—	CLKSEL1	CLKSEL0
bit 7						bit 0	

Legend:

R = Readable bit W = Writable bit U = Unimplemented bit, read as '0'
 -n = Value at POR '1' = Bit is set '0' = Bit is cleared x = Bit is unknown

- bit 15-11 **FDIV[4:0]:** Fractional Clock Divide bits
 00000 = No fractional clock division
 00001 = Increase period by 1 RTCC input clock cycle every 16 seconds
 00010 = Increase period by 2 RTCC input clock cycles every 16 seconds
 •
 •
 •
 11101 = Increase period by 30 RTCC input clock cycles every 16 seconds
 11111 = Increase period by 31 RTCC input clock cycles every 16 seconds
- bit 10-8 **Unimplemented:** Read as '0'
- bit 7-6 **PWCPS[1:0]:** Power Control Prescale Select bits
 00 = 1:1
 01 = 1:16
 10 = 1:64
 11 = 1:256
- bit 5-4 **PS[1:0]:** Prescale Select bits
 00 = 1:1
 01 = 1:16
 10 = 1:64
 11 = 1:256
- bit 3-2 **Unimplemented:** Read as '0'
- bit 1-0 **CLKSEL[1:0]:** Clock Select bits
 00 = SOSC
 01 = LPRC
 10 = PWRLCLK pin
 11 = System clock

21.3.2 RTCVAL REGISTER MAPPINGS

REGISTER 21-4: RTCCON2H: RTCC CONTROL REGISTER 2 (HIGH)⁽¹⁾

R/W-0	R/W-0	R/W-1	R/W-1	R/W-1	R/W-1	R/W-1	R/W-1
DIV[15:8]							
bit 15							bit 8

R/W-1	R/W-1	R/W-1	R/W-1	R/W-1	R/W-1	R/W-1	R/W-1
DIV[7:0]							
bit 7							bit 0

Legend:

R = Readable bit

W = Writable bit

U = Unimplemented bit, read as '0'

-n = Value at POR

'1' = Bit is set

'0' = Bit is cleared

x = Bit is unknown

bit 15-0 **DIV[15:0]:** Clock Divide bits

Sets the period of the clock divider counter; value should cause a nominal 1/2 second underflow.

Note 1: A write to this register is only allowed when WRLOCK = 1.

PIC24FJ256GA705 FAMILY

REGISTER 21-5: RTCCON3L: RTCC CONTROL REGISTER 3 (LOW)

R/W-0	R/W-0	R/W-0	R/W-0	R/W-0	R/W-0	R/W-0	R/W-0
PWCSTAB[7:0]							
bit 15				bit 8			

R/W-0	R/W-0	R/W-0	R/W-0	R/W-0	R/W-0	R/W-0	R/W-0
PWCSTAB[7:0]							
bit 7				bit 0			

Legend:							
R = Readable bit	W = Writable bit	U = Unimplemented bit, read as '0'					
-n = Value at POR	'1' = Bit is set	'0' = Bit is cleared	x = Bit is unknown				

bit 15-8 **PWCSAMP[7:0]:** Power Control Sample Window Timer bits
 11111111 = Sample window is always enabled, even when PWCEN = 0
 11111110 = Sample window is 254 TPWCCLK clock periods
 •
 •
 •
 00000001 = Sample window is 1 TPWCCLK clock period
 00000000 = No sample window

bit 7-0 **PWCSTAB[7:0]:** Power Control Stability Window Timer bits⁽¹⁾
 11111111 = Stability window is 255 TPWCCLK clock periods
 11111110 = Stability window is 254 TPWCCLK clock periods
 •
 •
 •
 00000001 = Stability window is 1 TPWCCLK clock period
 00000000 = No stability window; sample window starts when the alarm event triggers

Note 1: The sample window always starts when the stability window timer expires, except when its initial value is 00h.

PIC24FJ256GA705 FAMILY

REGISTER 21-6: RTCSTATL: RTCC STATUS REGISTER (LOW)

U-0	U-0	U-0	U-0	U-0	U-0	U-0	U-0
—	—	—	—	—	—	—	—
bit 15							bit 8

U-0	U-0	R/C-0	U-0	R/C-0	R-0	R-0	R-0
—	—	ALMEVT	—	TSAEVT ⁽¹⁾	SYNC	ALMSYNC	HALFSEC ⁽²⁾
bit 7							bit 0

Legend:	C = Clearable bit	U = Unimplemented bit, read as '0'
R = Readable bit	W = Writable bit	'0' = Bit is cleared
-n = Value at POR	'1' = Bit is set	x = Bit is unknown

bit 15-6 **Unimplemented:** Read as '0'

bit 5 **ALMEVT:** Alarm Event bit
 1 = An alarm event has occurred
 0 = An alarm event has not occurred

bit 4 **Unimplemented:** Read as '0'

bit 3 **TSAEVT:** Timestamp A Event bit⁽¹⁾
 1 = A timestamp event has occurred
 0 = A timestamp event has not occurred

bit 2 **SYNC:** Synchronization Status bit
 1 = TIME registers may change during software read
 0 = TIME registers may be read safely

bit 1 **ALMSYNC:** Alarm Synchronization Status bit
 1 = Alarm registers (ALMTIME and ALMDATE) and Alarm bits (AMASK[3:0]) should not be modified, and Alarm Control bits (ALRMEN, ALMRPT[7:0]) may change during software read
 0 = Alarm registers and Alarm Control bits may be written/modified safely

bit 0 **HALFSEC:** Half Second Status bit⁽²⁾
 1 = Second half period of a second
 0 = First half period of a second

Note 1: User software may write a '1' to this location to initiate a Timestamp A event; timestamp capture is not valid until TSAEVT reads as '1'.

2: This bit is read-only; it is cleared to '0' on a write to the SECONE[3:0] bits.

PIC24FJ256GA705 FAMILY

21.3.3 RTCC VALUE REGISTERS

REGISTER 21-7: TIMEL: RTCC TIME REGISTER (LOW)

U-0	R/W-x	R/W-x	R/W-x	R/W-x	R/W-x	R/W-x	R/W-x
—	SECTEN2	SECTEN1	SECTEN0	SECONE3	SECONE2	SECONE1	SECONE0
bit 15							bit 8

U-0	U-0	U-0	U-0	U-0	U-0	U-0	U-0
—	—	—	—	—	—	—	—
bit 7							bit 0

Legend:

R = Readable bit W = Writable bit U = Unimplemented bit, read as '0'
 -n = Value at POR '1' = Bit is set '0' = Bit is cleared x = Bit is unknown

- bit 15 **Unimplemented:** Read as '0'
- bit 14-12 **SECTEN[2:0]:** Binary Coded Decimal Value of Seconds '10' Digit bits
Contains a value from 0 to 5.
- bit 11-8 **SECONE[3:0]:** Binary Coded Decimal Value of Seconds '1' Digit bits
Contains a value from 0 to 9.
- bit 7-0 **Unimplemented:** Read as '0'

REGISTER 21-8: TIMEH: RTCC TIME REGISTER (HIGH)

U-0	U-0	R/W-0	R/W-x	R/W-x	R/W-x	R/W-x	R/W-x
—	—	HRTEN1	HRTEN0	HRONE3	HRONE2	HRONE1	HRONE0
bit 15							bit 8

U-0	R/W-0	R/W-0	R/W-x	R/W-x	R/W-x	R/W-x	R/W-x
—	MINTEN2	MINTEN1	MINTEN0	MINONE3	MINONE2	MINONE1	MINONE0
bit 7							bit 0

Legend:

R = Readable bit W = Writable bit U = Unimplemented bit, read as '0'
 -n = Value at POR '1' = Bit is set '0' = Bit is cleared x = Bit is unknown

- bit 15-14 **Unimplemented:** Read as '0'
- bit 13-12 **HRTEN[1:0]:** Binary Coded Decimal Value of Hours '10' Digit bits
Contains a value from 0 to 2.
- bit 11-8 **HRONE[3:0]:** Binary Coded Decimal Value of Hours '1' Digit bits
Contains a value from 0 to 9.
- bit 7 **Unimplemented:** Read as '0'
- bit 6-4 **MINTEN[2:0]:** Binary Coded Decimal Value of Minutes '10' Digit bits
Contains a value from 0 to 5.
- bit 3-0 **MINONE[3:0]:** Binary Coded Decimal Value of Minutes '1' Digit bits
Contains a value from 0 to 9.

PIC24FJ256GA705 FAMILY

REGISTER 21-9: DATEL: RTCC DATE REGISTER (LOW)

U-0	U-0	R/W-0	R/W-0	R/W-0	R/W-0	R/W-0	R/W-0
—	—	DAYTEN1	DAYTEN0	DAYONE3	DAYONE2	DAYONE1	DAYONE0
bit 15							bit 8

U-0	U-0	U-0	U-0	U-0	R/W-x	R/W-x	R/W-x
—	—	—	—	—	WDAY[2:0]		
bit 7						bit 0	

Legend:

R = Readable bit W = Writable bit U = Unimplemented bit, read as '0'
 -n = Value at POR '1' = Bit is set '0' = Bit is cleared x = Bit is unknown

- bit 15-14 **Unimplemented:** Read as '0'
- bit 13-12 **DAYTEN[1:0]:** Binary Coded Decimal Value of Days '10' Digit bits
Contains a value from 0 to 3.
- bit 11-8 **DAYONE[3:0]:** Binary Coded Decimal Value of Days '1' Digit bits
Contains a value from 0 to 9.
- bit 7-3 **Unimplemented:** Read as '0'
- bit 2-0 **WDAY[2:0]:** Binary Coded Decimal Value of Weekdays '1' Digit bits
Contains a value from 0 to 6.

REGISTER 21-10: DATEH: RTCC DATE REGISTER (HIGH)

R/W-0	R/W-0	R/W-0	R/W-0	R/W-x	R/W-x	R/W-x	R/W-x
YRTEN3	YRTEN2	YRTEN1	YRTEN0	YRONE3	YRONE2	YRONE1	YRONE0
bit 15							bit 8

U-0	U-0	U-0	R/W-x	R/W-x	R/W-x	R/W-x	R/W-x
—	—	—	MHTTEN	MTHONE3	MTHONE2	MTHONE1	MTHONE0
bit 7						bit 0	

Legend:

R = Readable bit W = Writable bit U = Unimplemented bit, read as '0'
 -n = Value at POR '1' = Bit is set '0' = Bit is cleared x = Bit is unknown

- bit 15-12 **YRTEN[3:0]:** Binary Coded Decimal Value of Years '10' Digit bits
- bit 11-8 **YRONE[3:0]:** Binary Coded Decimal Value of Years '1' Digit bits
- bit 7-5 **Unimplemented:** Read as '0'
- bit 4 **MHTTEN:** Binary Coded Decimal Value of Months '10' Digit bit
Contains a value from 0 to 1.
- bit 3-0 **MTHONE[3:0]:** Binary Coded Decimal Value of Months '1' Digit bits
Contains a value from 0 to 9.

PIC24FJ256GA705 FAMILY

21.3.4 ALARM VALUE REGISTERS

REGISTER 21-11: ALMTIMEL: RTCC ALARM TIME REGISTER (LOW)

U-0	R/W-0	R/W-0	R/W-0	R/W-0	R/W-0	R/W-0	R/W-0
—	SECTEN2	SECTEN1	SECTEN0	SECONE3	SECONE2	SECONE1	SECONE0
bit 15							bit 8

U-0	U-0	U-0	U-0	U-0	U-0	U-0	U-0
—	—	—	—	—	—	—	—
bit 7							bit 0

Legend:

R = Readable bit W = Writable bit U = Unimplemented bit, read as '0'
 -n = Value at POR '1' = Bit is set '0' = Bit is cleared x = Bit is unknown

- bit 15 **Unimplemented:** Read as '0'
- bit 14-12 **SECTEN[2:0]:** Binary Coded Decimal Value of Seconds '10' Digit bits
Contains a value from 0 to 5.
- bit 11-8 **SECONE[3:0]:** Binary Coded Decimal Value of Seconds '1' Digit bits
Contains a value from 0 to 9.
- bit 7-0 **Unimplemented:** Read as '0'

REGISTER 21-12: ALMTIMEH: RTCC ALARM TIME REGISTER (HIGH)

U-0	U-0	R/W-0	R/W-0	R/W-0	R/W-0	R/W-0	R/W-0
—	—	HRTEN1	HRTEN0	HRONE3	HRONE2	HRONE1	HRONE0
bit 15							bit 8

U-0	R/W-0	R/W-0	R/W-0	R/W-0	R/W-0	R/W-0	R/W-0
—	MINTEN2	MINTEN1	MINTEN0	MINONE3	MINONE2	MINONE1	MINONE0
bit 7							bit 0

Legend:

R = Readable bit W = Writable bit U = Unimplemented bit, read as '0'
 -n = Value at POR '1' = Bit is set '0' = Bit is cleared x = Bit is unknown

- bit 15-14 **Unimplemented:** Read as '0'
- bit 13-12 **HRTEN[1:0]:** Binary Coded Decimal Value of Hours '10' Digit bits
Contains a value from 0 to 2.
- bit 11-8 **HRONE[3:0]:** Binary Coded Decimal Value of Hours '1' Digit bits
Contains a value from 0 to 9.
- bit 7 **Unimplemented:** Read as '0'
- bit 6-4 **MINTEN[2:0]:** Binary Coded Decimal Value of Minutes '10' Digit bits
Contains a value from 0 to 5.
- bit 3-0 **MINONE[3:0]:** Binary Coded Decimal Value of Minutes '1' Digit bits
Contains a value from 0 to 9.

PIC24FJ256GA705 FAMILY

REGISTER 21-13: ALMDATEL: RTCC ALARM DATE REGISTER (LOW)

U-0	U-0	R/W-0	R/W-0	R/W-0	R/W-0	R/W-0	R/W-0
—	—	DAYTEN1	DAYTEN0	DAYONE3	DAYONE2	DAYONE1	DAYONE0
bit 15							bit 8

U-0	U-0	U-0	U-0	U-0	R/W-0	R/W-0	R/W-0
—	—	—	—	—	WDAY[2:0]		
bit 7						bit 0	

Legend:

R = Readable bit W = Writable bit U = Unimplemented bit, read as '0'
 -n = Value at POR '1' = Bit is set '0' = Bit is cleared x = Bit is unknown

- bit 15-14 **Unimplemented:** Read as '0'
- bit 13-12 **DAYTEN[1:0]:** Binary Coded Decimal Value of Days '10' Digit bits
Contains a value from 0 to 3.
- bit 11-8 **DAYONE[3:0]:** Binary Coded Decimal Value of Days '1' Digit bits
Contains a value from 0 to 9.
- bit 7-3 **Unimplemented:** Read as '0'
- bit 2-0 **WDAY[2:0]:** Binary Coded Decimal Value of Weekdays '1' Digit bits
Contains a value from 0 to 6.

REGISTER 21-14: ALMDATEH: RTCC ALARM DATE REGISTER (HIGH)

R/W-0	R/W-0	R/W-0	R/W-0	R/W-0	R/W-0	R/W-0	R/W-0
YRTEN3	YRTEN2	YRTEN1	YRTEN0	YRONE3	YRONE2	YRONE1	YRONE0
bit 15							bit 8

U-0	U-0	U-0	R/W-0	R/W-0	R/W-0	R/W-0	R/W-0
—	—	—	MHTTEN	MTHONE3	MTHONE2	MTHONE1	MTHONE0
bit 7						bit 0	

Legend:

R = Readable bit W = Writable bit U = Unimplemented bit, read as '0'
 -n = Value at POR '1' = Bit is set '0' = Bit is cleared x = Bit is unknown

- bit 15-12 **YRTEN[3:0]:** Binary Coded Decimal Value of Years '10' Digit bits
- bit 11-8 **YRONE[3:0]:** Binary Coded Decimal Value of Years '1' Digit bits
- bit 7-5 **Unimplemented:** Read as '0'
- bit 4 **MHTTEN:** Binary Coded Decimal Value of Months '10' Digit bit
Contains a value from 0 to 1.
- bit 3-0 **MTHONE[3:0]:** Binary Coded Decimal Value of Months '1' Digit bits
Contains a value from 0 to 9.

PIC24FJ256GA705 FAMILY

21.3.5 TIMESTAMP REGISTERS

REGISTER 21-15: TSATIMEL: RTCC TIMESTAMP A TIME REGISTER (LOW)⁽¹⁾

U-0	R/W-0	R/W-0	R/W-0	R/W-0	R/W-0	R/W-0	R/W-0
—	SECTEN2	SECTEN1	SECTEN0	SECONE3	SECONE2	SECONE1	SECONE0
bit 15							bit 8

U-0	U-0	U-0	U-0	U-0	U-0	U-0	U-0
—	—	—	—	—	—	—	—
bit 7							bit 0

Legend:

R = Readable bit

W = Writable bit

U = Unimplemented bit, read as '0'

-n = Value at POR

'1' = Bit is set

'0' = Bit is cleared

x = Bit is unknown

bit 15 **Unimplemented:** Read as '0'

bit 14-12 **SECTEN[2:0]:** Binary Coded Decimal Value of Seconds '10' Digit bits
Contains a value from 0 to 5.

bit 11-8 **SECONE[3:0]:** Binary Coded Decimal Value of Seconds '1' Digit bits
Contains a value from 0 to 9.

bit 7-0 **Unimplemented:** Read as '0'

Note 1: If TSAEN = 0, bits[15:0] can be used for persistent storage throughout a non-Power-on Reset ($\overline{\text{MCLR}}$, WDT, etc.).

PIC24FJ256GA705 FAMILY

REGISTER 21-16: TSATIMEH: RTCC TIMESTAMP A TIME REGISTER (HIGH)⁽¹⁾

U-0	U-0	R/W-0	R/W-0	R/W-0	R/W-0	R/W-0	R/W-0
—	—	HRTEN1	HRTEN0	HRONE3	HRONE2	HRONE1	HRONE0
bit 15							bit 8

U-0	R/W-0	R/W-0	R/W-0	R/W-0	R/W-0	R/W-0	R/W-0
—	MINTEN2	MINTEN1	MINTEN0	MINONE3	MINONE2	MINONE1	MINONE0
bit 7							bit 0

Legend:

R = Readable bit

W = Writable bit

U = Unimplemented bit, read as '0'

-n = Value at POR

'1' = Bit is set

'0' = Bit is cleared

x = Bit is unknown

bit 15-14 **Unimplemented:** Read as '0'

bit 13-12 **HRTEN[1:0]:** Binary Coded Decimal Value of Hours '10' Digit bits
Contains a value from 0 to 2.

bit 11-8 **HRONE[3:0]:** Binary Coded Decimal Value of Hours '1' Digit bits
Contains a value from 0 to 9.

bit 7 **Unimplemented:** Read as '0'

bit 6-4 **MINTEN[2:0]:** Binary Coded Decimal Value of Minutes '10' Digit bits
Contains a value from 0 to 5.

bit 3-0 **MINONE[3:0]:** Binary Coded Decimal Value of Minutes '1' Digit bits
Contains a value from 0 to 9.

Note 1: If TSAEN = 0, bits[15:0] can be used for persistence storage throughout a non-Power-on Reset ($\overline{\text{MCLR}}$, WDT, etc.).

PIC24FJ256GA705 FAMILY

REGISTER 21-17: TSADATEL: RTCC TIMESTAMP A DATE REGISTER (LOW)⁽¹⁾

U-0	U-0	R/W-0	R/W-0	R/W-0	R/W-0	R/W-0	R/W-0
—	—	DAYTEN1	DAYTEN0	DAYONE3	DAYONE2	DAYONE1	DAYONE0
bit 15							bit 8

U-0	U-0	U-0	U-0	U-0	R/W-0	R/W-0	R/W-0
—	—	—	—	—	WDAY[2:0]		
bit 7						bit 0	

Legend:

R = Readable bit

W = Writable bit

U = Unimplemented bit, read as '0'

-n = Value at POR

'1' = Bit is set

'0' = Bit is cleared

x = Bit is unknown

bit 15-14 **Unimplemented:** Read as '0'

bit 13-12 **DAYTEN[1:0]:** Binary Coded Decimal Value of Days '10' Digit bits
Contains a value from 0 to 3.

bit 11-8 **DAYONE[3:0]:** Binary Coded Decimal Value of Days '1' Digit bits
Contains a value from 0 to 9.

bit 7-3 **Unimplemented:** Read as '0'

bit 2-0 **WDAY[2:0]:** Binary Coded Decimal Value of Weekdays '1' Digit bits
Contains a value from 0 to 6.

Note 1: If TSAEN = 0, bits[15:0] can be used for persistence storage throughout a non-Power-on Reset ($\overline{\text{MCLR}}$, WDT, etc.).

PIC24FJ256GA705 FAMILY

REGISTER 21-18: TSADATEH: RTCC TIMESTAMP A DATE REGISTER (HIGH)⁽¹⁾

R/W-0	R/W-0	R/W-0	R/W-0	R/W-0	R/W-0	R/W-0	R/W-0
YRTEN3	YRTEN2	YRTEN1	YRTEN0	YRONE3	YRONE2	YRONE1	YRONE0
bit 15							bit 8

U-0	U-0	U-0	R/W-0	R/W-0	R/W-0	R/W-0	R/W-0
—	—	—	MHTTEN	MTHONE3	MTHONE2	MTHONE1	MTHONE0
bit 7							bit 0

Legend:

R = Readable bit W = Writable bit U = Unimplemented bit, read as '0'
 -n = Value at POR '1' = Bit is set '0' = Bit is cleared x = Bit is unknown

- bit 15-12 **YRTEN[3:0]:** Binary Coded Decimal Value of Years '10' Digit bits
- bit 11-8 **YRONE[3:0]:** Binary Coded Decimal Value of Years '1' Digit bits
- bit 7-5 **Unimplemented:** Read as '0'
- bit 4 **MHTTEN:** Binary Coded Decimal Value of Months '10' Digit bit
Contains a value from 0 to 1.
- bit 3-0 **MTHONE[2:0]:** Binary Coded Decimal Value of Months '1' Digit bits
Contains a value from 0 to 9.

Note 1: If TSAEN = 0, bits[15:0] can be used for persistence storage throughout a non-Power-on Reset ($\overline{\text{MCLR}}$, WDT, etc.).

PIC24FJ256GA705 FAMILY

21.4 Calibration

21.4.1 CLOCK SOURCE CALIBRATION

A crystal oscillator that is connected to the RTCC may be calibrated to provide an accurate one second clock in two ways. First, coarse frequency adjustment is performed by adjusting the value written to the DIV[15:0] bits. Secondly, a 5-bit value can be written to the FDIV[4:0] control bits to perform a fine clock division.

The DIVx and FDIVx values can be concatenated and considered as a 21-bit prescaler value. If the oscillator source is slightly faster than ideal, the FDIV[4:0] value can be increased to make a small decrease in the RTC frequency. The value of DIV[15:0] should be increased to make larger decreases in the RTC frequency. If the oscillator source is slower than ideal, FDIV[4:0] may be decreased for small calibration changes and DIV[15:0] may need to be decreased to make larger calibration changes.

Before calibration, the user must determine the error of the crystal. This should be done using another timer resource on the device or an external timing reference. It is up to the user to include in the error value, the initial error of the crystal, drift due to temperature and drift due to crystal aging.

21.5 Alarm

- Configurable from half second to one year
- Enabled using the ALRMEN bit (RTCCON1H[15])
- One-time alarm and repeat alarm options are available

21.5.1 CONFIGURING THE ALARM

The alarm feature is enabled using the ALRMEN bit. This bit is cleared when an alarm is issued. Writes to the Alarm Value registers should only take place when ALRMEN = 0.

As shown in [Figure 21-2](#), the interval selection of the alarm is configured through the AMASK[3:0] bits (RTCCON1H[11:8]). These bits determine which and how many digits of the alarm must match the clock value for the alarm to occur.

The alarm can also be configured to repeat based on a preconfigured interval. The amount of times this occurs, once the alarm is enabled, is stored in the ALMRPT[7:0] bits (RTCCON1H[7:0]). When the value of the ALMRPTx bits equals 00h and the CHIME bit (RTCCON1H[14]) is cleared, the repeat function is disabled and only a single alarm will occur. The alarm can be repeated, up to 255 times, by loading ALMRPT[7:0] with FFh.

After each alarm is issued, the value of the ALMRPTx bits is decremented by one. Once the value has reached 00h, the alarm will be issued one last time, after which, the ALRMEN bit will be cleared automatically and the alarm will turn off.

Indefinite repetition of the alarm can occur if the CHIME bit = 1. Instead of the alarm being disabled when the value of the ALMRPTx bits reaches 00h, it rolls over to FFh and continues counting indefinitely while CHIME is set.

21.5.2 ALARM INTERRUPT

At every alarm event, an interrupt is generated. This output is completely synchronous to the RTCC clock and can be used as a trigger clock to the other peripherals.

Note: Changing any of the register bits, other than the RTCOE bit (RTCCON1L[7]), the ALMRPT[7:0] bits (RTCCON1H[7:0]) and the CHIME bit, while the alarm is enabled (ALRMEN = 1), can result in a false alarm event leading to a false alarm interrupt. To avoid a false alarm event, the timer and alarm values should only be changed while the alarm is disabled (ALRMEN = 0).

FIGURE 21-2: ALARM MASK SETTINGS

Alarm Mask Setting (AMASK[3:0])	Day of the Week	Month	Day	Hours	Minutes	Seconds
0000 - Every half second 0001 - Every second	<input type="checkbox"/>	<input type="checkbox"/> <input type="checkbox"/> / <input type="checkbox"/> <input type="checkbox"/>	<input type="checkbox"/> <input type="checkbox"/>	<input type="checkbox"/> <input type="checkbox"/> : <input type="checkbox"/> <input type="checkbox"/>	<input type="checkbox"/> <input type="checkbox"/> : <input type="checkbox"/> <input type="checkbox"/>	<input type="checkbox"/> <input type="checkbox"/>
0010 - Every 10 seconds	<input type="checkbox"/>	<input type="checkbox"/> <input type="checkbox"/> / <input type="checkbox"/> <input type="checkbox"/>	<input type="checkbox"/> <input type="checkbox"/>	<input type="checkbox"/> <input type="checkbox"/> : <input type="checkbox"/> <input type="checkbox"/>	<input type="checkbox"/> <input type="checkbox"/> : <input type="checkbox"/> <input type="checkbox"/>	<input type="checkbox"/> s
0011 - Every minute	<input type="checkbox"/>	<input type="checkbox"/> <input type="checkbox"/> / <input type="checkbox"/> <input type="checkbox"/>	<input type="checkbox"/> <input type="checkbox"/>	<input type="checkbox"/> <input type="checkbox"/> : <input type="checkbox"/> <input type="checkbox"/>	<input type="checkbox"/> <input type="checkbox"/> : s	s
0100 - Every 10 minutes	<input type="checkbox"/>	<input type="checkbox"/> <input type="checkbox"/> / <input type="checkbox"/> <input type="checkbox"/>	<input type="checkbox"/> <input type="checkbox"/>	<input type="checkbox"/> <input type="checkbox"/> : <input type="checkbox"/> m	<input type="checkbox"/> <input type="checkbox"/> : s	s
0101 - Every hour	<input type="checkbox"/>	<input type="checkbox"/> <input type="checkbox"/> / <input type="checkbox"/> <input type="checkbox"/>	<input type="checkbox"/> <input type="checkbox"/>	<input type="checkbox"/> <input type="checkbox"/> : m	m : s	s
0110 - Every day	<input type="checkbox"/>	<input type="checkbox"/> <input type="checkbox"/> / <input type="checkbox"/> <input type="checkbox"/>	<input type="checkbox"/> <input type="checkbox"/>	h h : m	m : s	s
0111 - Every week	d	<input type="checkbox"/> <input type="checkbox"/> / <input type="checkbox"/> <input type="checkbox"/>	<input type="checkbox"/> <input type="checkbox"/>	h h : m	m : s	s
1000 - Every month	<input type="checkbox"/>	<input type="checkbox"/> <input type="checkbox"/> / d	d	h h : m	m : s	s
1001 - Every year ⁽¹⁾	<input type="checkbox"/>	m m / d	d	h h : m	m : s	s

Note 1: Annually, except when configured for February 29.

21.6 Power Control

The RTCC includes a power control feature that allows the device to periodically wake-up an external device, wait for the device to be stable before sampling wake-up events from that device and then shut down the external device. This can be done completely autonomously by the RTCC, without the need to wake-up from the current lower power mode.

To use this feature:

1. Enable the RTCC (RTCEN = 1).
2. Set the PWCEN bit (RTCCON1L[10]).
3. Configure the RTCC pin to drive the PWC control signal (RTCOE = 1 and OUTSEL[2:0] = 011).

The polarity of the PWC control signal may be chosen using the PWCPOL bit (RTCCON1L[9]). An active-low or active-high signal may be used with the appropriate external switch to turn on or off the power to one or more external devices. The active-low setting may also be used in conjunction with an open-drain setting on the RTCC pin, in order to drive the ground pin(s) of the external device directly (with the appropriate external VDD pull-up device), without the need for external switches. Finally, the CHIME bit should be set to enable the PWC periodicity.

Once the RTCC and PWC are enabled and running, the PWC logic will generate a control output and a sample gate output. The control output is driven out on the RTCC pin (when RTCOE = 1 and OUTSEL[2:0] = 011) and is used to power up or down the device, as described above.

Once the control output is asserted, the stability window begins, in which the external device is given enough time to power up and provide a stable output.

Once the output is stable, the RTCC provides a sample gate during the sample window. The use of this sample gate depends on the external device being used, but typically, it is used to mask out one or more wake-up signals from the external device.

Finally, both the stability and the sample windows close after the expiration of the sample window and the external device is powered down.

PIC24FJ256GA705 FAMILY

21.6.1 POWER CONTROL CLOCK SOURCE

The stability and sample windows are controlled by the PWCSAMPx and PWCSTABx bit fields in the RTCCON3L register (RTCCON3L[15:8] and [7:0], respectively). As both the stability and sample windows are defined in terms of the RTCC clock, their absolute values vary by the value of the PWC clock base period (TPWCCLK). For example, using a 32.768 kHz SOSC input clock would produce a TPWCCLK of $1/32768 = 30.518 \mu\text{s}$. The 8-bit magnitude of PWCSTABx and PWCSAMPx allows for a window size of 0 to 255 TPWCCLK. The period of the PWC clock can also be adjusted with a 1:1, 1:16, 1:64 or 1:256 prescaler, determined by the PWCPS[1:0] bits (RTCCON2L[7:6]).

In addition, certain values for the PWCSTABx and PWCSAMPx fields have specific control meanings in determining power control operations. If either bit field is 00h, the corresponding window is inactive. In addition, if the PWCSTABx field is FFh, the stability window remains active continuously, even if power control is disabled.

21.7 Event Timestamping

The RTCC includes a set of Timestamp registers that may be used for the capture of Time and Date register values when an external input signal is received. The RTCC will trigger a timestamp event when a low pulse occurs on the TMPRN pin.

21.7.1 TIMESTAMP OPERATION

The event input is enabled for timestamping using the TSAEN bit (RTCCON1L[0]). When the timestamp event occurs, the present time and date values will be stored in the TSATIMEL/H and TSADATEL/H registers, the TSAEVT status bit (RTCSTATL[3]) will be set and an RTCC interrupt will occur. A new timestamp capture event cannot occur until the user clears the TSAEVT status bit.

Note 1: The TSATIMEL/H and TSADATEL/H register pairs can be used for data storage when TSAEN = 0. The values of TSATIMEL/H and TSADATEL/H will be maintained throughout all types of non-Power-on Resets (MCLR, WDT, etc).

21.7.2 MANUAL TIMESTAMP OPERATION

The current time and date may be captured in the TSATIMEL/H and TSADATEL/H registers by writing a '1' to the TSAEVT bit location while the timestamp functionality is enabled (TSAEN = 1). This write will not set the TSAEVT bit, but it will initiate a timestamp capture. The TSAEVT bit will be set when the capture operation is complete. The user must poll the TSAEVT bit to determine when the capture operation is complete.

After the Timestamp registers have been read, the TSAEVT bit should be cleared to allow further hardware or software timestamp capture events.

22.0 32-BIT PROGRAMMABLE CYCLIC REDUNDANCY CHECK (CRC) GENERATOR

Note: This data sheet summarizes the features of this group of PIC24F devices. It is not intended to be a comprehensive reference source. For more information, refer to “32-Bit Programmable Cyclic Redundancy Check (CRC)” (www.microchip.com/DS30009729) in the “dsPIC33/PIC24 Family Reference Manual”. The information in this data sheet supersedes the information in the FRM.

The 32-bit programmable CRC generator provides a hardware implemented method of quickly generating checksums for various networking and security applications. It offers the following features:

- User-Programmable CRC Polynomial Equation, up to 32 Bits
- Programmable Shift Direction (little or big-endian)
- Independent Data and Polynomial Lengths
- Configurable Interrupt Output
- Data FIFO

Figure 22-1 displays a simplified block diagram of the CRC generator. A simple version of the CRC shift engine is displayed in Figure 22-2.

FIGURE 22-1: CRC BLOCK DIAGRAM

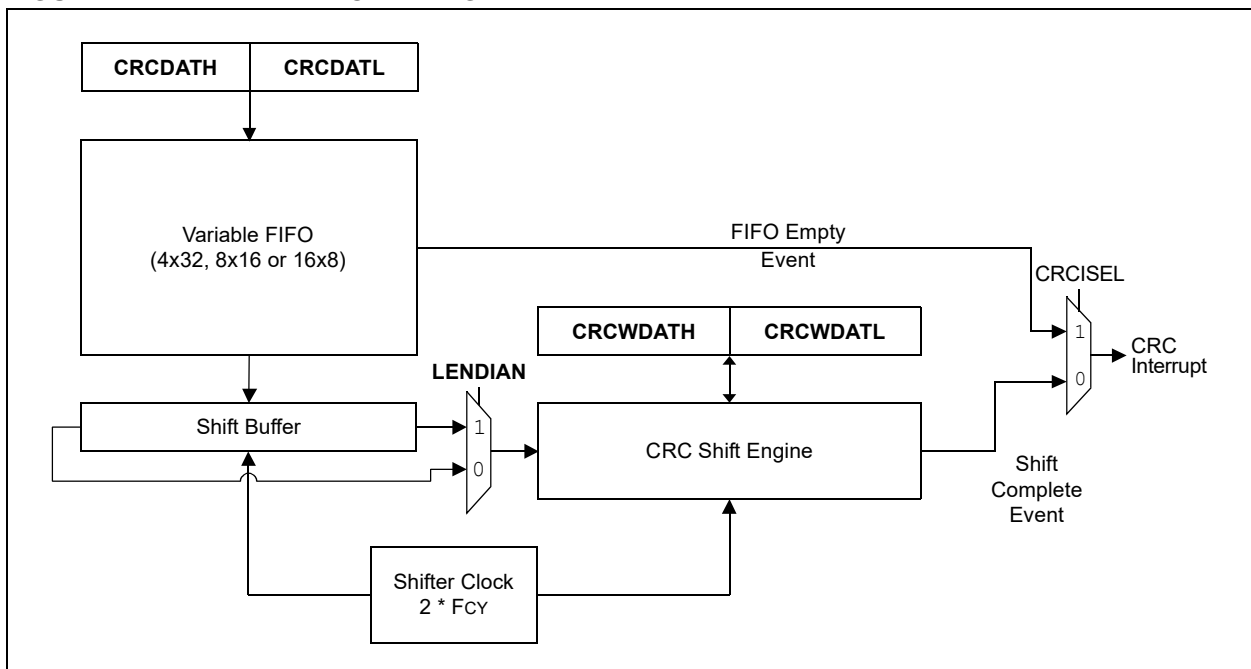
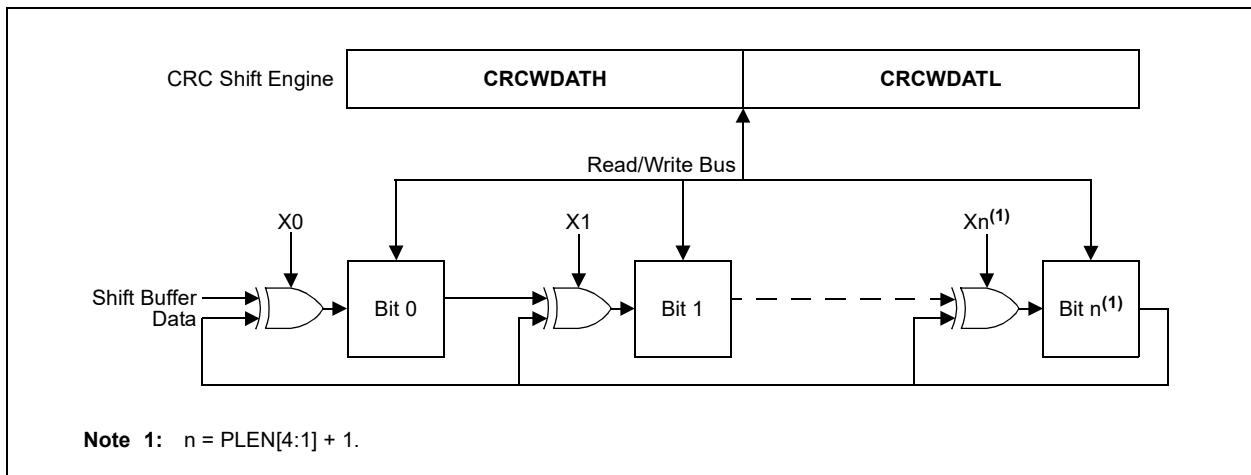

FIGURE 22-2: CRC SHIFT ENGINE DETAIL



PIC24FJ256GA705 FAMILY

22.1 User Interface

22.1.1 POLYNOMIAL INTERFACE

The CRC module can be programmed for CRC polynomials of up to the 32nd order, using up to 32 bits.

Polynomial length, which reflects the highest exponent in the equation, is selected by the PLEN[4:0] bits (CRC-CON2[4:0]).

The CRCXORL and CRCXORH registers control which exponent terms are included in the equation. Setting a particular bit includes that exponent term in the equation. Functionally, this includes an XOR operation on the corresponding bit in the CRC engine. Clearing the bit disables the XOR.

For example, consider two CRC polynomials, one a 16-bit and the other a 32-bit equation.

EQUATION 22-1: 16-BIT, 32-BIT CRC POLYNOMIALS

$X^{16} + X^{12} + X^5 + 1$
and
$X^{32} + X^{26} + X^{23} + X^{22} + X^{16} + X^{12} + X^{11} + X^{10} + X^8 + X^7 + X^5 + X^4 + X^2 + X + 1$

To program these polynomials into the CRC generator, set the register bits, as shown in [Table 22-1](#).

Note that the appropriate positions are set to '1' to indicate that they are used in the equation (for example, X26 and X23). The '0' bit required by the equation is always XORed; thus, X0 is a don't care. For a polynomial of length 32, it is assumed that the 32nd bit will be used. Therefore, the X[31:1] bits do not have the 32nd bit.

22.1.2 DATA INTERFACE

The module incorporates a FIFO that works with a variable data width. Input data width can be configured to any value between 1 and 32 bits using the DWIDTH[4:0] bits (CRCCON2[12:8]). When the data width is greater than 15, the FIFO is four words deep. When the DWIDTHx bits are between 15 and 8, the FIFO is eight words deep. When the DWIDTHx bits are less than eight, the FIFO is 16 words deep.

The data for which the CRC is to be calculated must first be written into the FIFO. Even if the data width is less than 8, the smallest data element that can be written into the FIFO is 1 byte. For example, if the DWIDTHx bits are 5, then the size of the data is DWIDTH[4:0] + 1 or 6. The data are written as a whole byte; the two unused upper bits are ignored by the module.

Once data are written into the MSb of the CRCDAT registers (that is, the MSb as defined by the data width), the value of the VWORD[4:0] bits (CRCCON1[12:8]) increments by one. For example, if the DWIDTHx bits are 24, the VWORDx bits will increment when bit 7 of CRCDATH is written. Therefore, CRCDATL must always be written to before CRCDATH.

The CRC engine starts shifting data when the CRCGO bit (CRCCON1[4]) is set and the value of the VWORDx bits is greater than zero.

Each word is copied out of the FIFO into a buffer register, which decrements the VWORDx bits. The data are then shifted out of the buffer. The CRC engine continues shifting at a rate of two bits per instruction cycle, until the VWORDx bits reach zero. This means that for a given data width, it takes half that number of instructions for each word to complete the calculation. For example, it takes 16 cycles to calculate the CRC for a single word of 32-bit data.

When the VWORDx bits reach the maximum value for the configured value of the DWIDTHx bits (4, 8 or 16), the CRCFUL bit (CRCCON1[7]) becomes set. When the VWORDx bits reach zero, the CRCMPT bit (CRCCON1[6]) becomes set. The FIFO is emptied and the VWORD[4:0] bits are set to '00000' whenever CRCEN is '0'.

At least one instruction cycle must pass after a write to CRCWDAT before a read of the VWORDx bits is done.

TABLE 22-1: CRC SETUP EXAMPLES FOR 16 AND 32-BIT POLYNOMIALS

CRC Control Bits	Bit Values	
	16-Bit Polynomial	32-Bit Polynomial
PLEN[4:0]	01111	11111
X[31:16]	0000 0000 0000 0001	0000 0100 1100 0001
X[15:1]	0001 0000 0010 000	0001 1101 1011 011

22.1.3 DATA SHIFT DIRECTION

The LENDIAN bit (CRCCON1[3]) is used to control the shift direction. By default, the CRC will shift data through the engine, MSb first. Setting LENDIAN (= 1) causes the CRC to shift data, LSb first. This setting allows better integration with various communication schemes and removes the overhead of reversing the bit order in software. Note that this only changes the direction that the data are shifted into the engine. The result of the CRC calculation will still be a normal CRC result, not a reverse CRC result.

22.1.4 INTERRUPT OPERATION

The module generates an interrupt that is configurable by the user for either of two conditions.

If CRCISEL is '0', an interrupt is generated when the VWORD[4:0] bits make a transition from a value of '1' to '0'. If CRCISEL is '1', an interrupt will be generated after the CRC operation finishes and the module sets the CRCGO bit to '0'. Manually setting CRCGO to '0' will not generate an interrupt. Note that when an interrupt occurs, the CRC calculation would not yet be complete. The module will still need $(PLEN_x + 1)/2$ clock cycles after the interrupt is generated until the CRC calculation is finished.

22.1.5 TYPICAL OPERATION

To use the module for a typical CRC calculation:

1. Set the CRCEN bit to enable the module.
2. Configure the module for desired operation:
 - a) Program the desired polynomial using the CRCXOR registers and PLEN[4:0] bits.
 - b) Configure the data width and shift direction using the DWIDTH[4:0] and LENDIAN bits.
3. Set the CRCGO bit to start the calculations.
4. Set the desired CRC non-direct initial value by writing to the CRCWDAT registers.
5. Load all data into the FIFO by writing to the CRCDAT registers as space becomes available (the CRCFUL bit must be zero before the next data loading).
6. Wait until the data FIFO is empty (CRCMPT bit is set).
7. Read the result:

If the data width (DWIDTH[4:0] bits) is more than the polynomial length (PLEN[4:0] bits):

 - a) Wait $(DWIDTH[4:0] + 1)/2$ instruction cycles to make sure that shifts from the shift buffer are finished.
 - b) Change the data width to the polynomial length ($DWIDTH[4:0] = PLEN[4:0]$).
 - c) Write one dummy data word to the CRCDAT registers.
 - d) Wait two instruction cycles to move the data from the FIFO to the shift buffer and $(PLEN[4:0] + 1)/2$ instruction cycles to shift out the result.

Or, if the data width (DWIDTH[4:0] bits) is less than the polynomial length (PLEN[4:0] bits):

1. Clear the CRC Interrupt Selection bit (CRCISEL = 0) to get the interrupt when all shifts are done. Clear the CRC interrupt flag. Write dummy data in the CRCDAT registers and wait until the CRC interrupt flag is set.
2. Read the final CRC result from the CRCWDAT registers.
3. Restore the data width (DWIDTH[4:0] bits) for further calculations (optional). If the data width (DWIDTH[4:0] bits) is equal to, or less than, the polynomial length (PLEN[4:0] bits):
 - a) Clear the CRC Interrupt Selection bit (CRCISEL = 0) to get the interrupt when all shifts are done.
 - b) Suspend the calculation by setting CRCGO = 0.
 - c) Clear the CRC interrupt flag.
 - d) Write the dummy data with the total data length equal to the polynomial length in the CRCDAT registers.
 - e) Resume the calculation by setting CRCGO = 1.
 - f) Wait until the CRC interrupt flag is set.
 - g) Read the final CRC result from the CRCWDAT registers.

There are eight registers used to control programmable CRC operation:

- CRCCON1
- CRCCON2
- CRCXORL
- CRCXORH
- CRCDATL
- CRCDATH
- CRCWDATL
- CRCWDATH

The CRCCON1 and CRCCON2 registers ([Register 22-1](#) and [Register 22-2](#)) control the operation of the module and configure the various settings.

The CRCXOR registers ([Register 22-3](#) and [Register 22-4](#)) select the polynomial terms to be used in the CRC equation. The CRCDAT and CRCWDAT registers are each register pairs that serve as buffers for the double-word input data, and CRC processed output, respectively.

PIC24FJ256GA705 FAMILY

REGISTER 22-1: CRCCON1: CRC CONTROL 1 REGISTER

R/W-0	U-0	R/W-0	HSC/R-0	HSC/R-0	HSC/R-0	HSC/R-0	HSC/R-0
CRGEN	—	CSIDL	VWORD4	VWORD3	VWORD2	VWORD1	VWORD0
bit 15							bit 8

HSC/R-0	HSC/R-1	R/W-0	HC/R/W-0	R/W-0	U-0	U-0	U-0
CRCFUL	CRCMPT	CRCISEL	CRCGO	LENDIAN	—	—	—
bit 7							bit 0

Legend:	HC = Hardware Clearable bit	HSC = Hardware Settable/Clearable bit
R = Readable bit	W = Writable bit	U = Unimplemented bit, read as '0'
-n = Value at POR	'1' = Bit is set	'0' = Bit is cleared x = Bit is unknown

- bit 15 **CRGEN:** CRC Enable bit
 1 = Enables module
 0 = Disables module; all state machines, pointers and CRCWDAT/CRCDAT registers reset; other SFRs are NOT reset
- bit 14 **Unimplemented:** Read as '0'
- bit 13 **CSIDL:** CRC Stop in Idle Mode bit
 1 = Discontinues module operation when device enters Idle mode
 0 = Continues module operation in Idle mode
- bit 12-8 **VWORD[4:0]:** CRC Pointer Value bits
 Indicates the number of valid words in the FIFO. Has a maximum value of 8 when PLEN[4:0] ≥ 7 or 16 when PLEN[4:0] ≤ 7.
- bit 7 **CRCFUL:** CRC FIFO Full bit
 1 = FIFO is full
 0 = FIFO is not full
- bit 6 **CRCMPT:** CRC FIFO Empty bit
 1 = FIFO is empty
 0 = FIFO is not empty
- bit 5 **CRCISEL:** CRC Interrupt Selection bit
 1 = Interrupt on FIFO is empty; the final word of data is still shifting through the CRC
 0 = Interrupt on shift is complete and results are ready
- bit 4 **CRCGO:** Start CRC bit
 1 = Starts CRC serial shifter
 0 = CRC serial shifter is turned off
- bit 3 **LENDIAN:** Data Shift Direction Select bit
 1 = Data word is shifted into the CRC, starting with the LSb (little endian)
 0 = Data word is shifted into the CRC, starting with the MSb (big endian)
- bit 2-0 **Unimplemented:** Read as '0'

PIC24FJ256GA705 FAMILY

REGISTER 22-2: CRCCON2: CRC CONTROL 2 REGISTER

U-0	U-0	U-0	R/W-0	R/W-0	R/W-0	R/W-0	R/W-0
—	—	—	DWIDTH[4:0]				
bit 15							bit 8

U-0	U-0	U-0	R/W-0	R/W-0	R/W-0	R/W-0	R/W-0
—	—	—	PLEN[4:0]				
bit 7							bit 0

Legend:

R = Readable bit

W = Writable bit

U = Unimplemented bit, read as '0'

-n = Value at POR

'1' = Bit is set

'0' = Bit is cleared

x = Bit is unknown

bit 15-13 **Unimplemented:** Read as '0'

bit 12-8 **DWIDTH[4:0]:** CRC Data Word Width Configuration bits
Configures the width of the data word (Data Word Width – 1).

bit 7-5 **Unimplemented:** Read as '0'

bit 4-0 **PLEN[4:0]:** Polynomial Length Configuration bits
Configures the length of the polynomial (Polynomial Length – 1).

PIC24FJ256GA705 FAMILY

REGISTER 22-3: CRCXORL: CRC XOR POLYNOMIAL REGISTER, LOW WORD

R/W-0	R/W-0	R/W-0	R/W-0	R/W-0	R/W-0	R/W-0	R/W-0
X[15:8]							
bit 15							bit 8

R/W-0	R/W-0	R/W-0	R/W-0	R/W-0	R/W-0	R/W-0	U-0
X[7:1]							—
bit 7							bit 0

Legend:

R = Readable bit W = Writable bit U = Unimplemented bit, read as '0'
 -n = Value at POR '1' = Bit is set '0' = Bit is cleared x = Bit is unknown

bit 15-1 **X[15:1]:** XOR of Polynomial Term x^n Enable bits

bit 0 **Unimplemented:** Read as '0'

REGISTER 22-4: CRCXORH: CRC XOR POLYNOMIAL REGISTER, HIGH WORD

R/W-0	R/W-0	R/W-0	R/W-0	R/W-0	R/W-0	R/W-0	R/W-0
X[31:24]							
bit 15							bit 8

R/W-0	R/W-0	R/W-0	R/W-0	R/W-0	R/W-0	R/W-0	R/W-0
X[23:16]							
bit 7							bit 0

Legend:

R = Readable bit W = Writable bit U = Unimplemented bit, read as '0'
 -n = Value at POR '1' = Bit is set '0' = Bit is cleared x = Bit is unknown

bit 15-0 **X[31:16]:** XOR of Polynomial Term x^n Enable bits

23.0 CONFIGURABLE LOGIC CELL (CLC) GENERATOR

Note: This data sheet summarizes the features of this group of PIC24F devices. It is not intended to be a comprehensive reference source. For more information, refer to “**Configurable Logic Cell (CLC)**” (www.microchip.com/DS70005298) in the “*dsPIC33/PIC24 Family Reference Manual*”. The information in this data sheet supersedes the information in the FRM.

The Configurable Logic Cell (CLC) module allows the user to specify combinations of signals as inputs to a logic function and to use the logic output to control other peripherals or I/O pins. This provides greater flexibility and potential in embedded designs, since the CLC module can operate outside the limitations of software execution and supports a vast amount of output designs.

There are four input gates to the selected logic function. These four input gates select from a pool of up to 32 signals that are selected using four data source selection multiplexers. Figure 23-1 shows an overview of the module. Figure 23-3 shows the details of the data source multiplexers and logic input gate connections.

FIGURE 23-1: CLCx MODULE

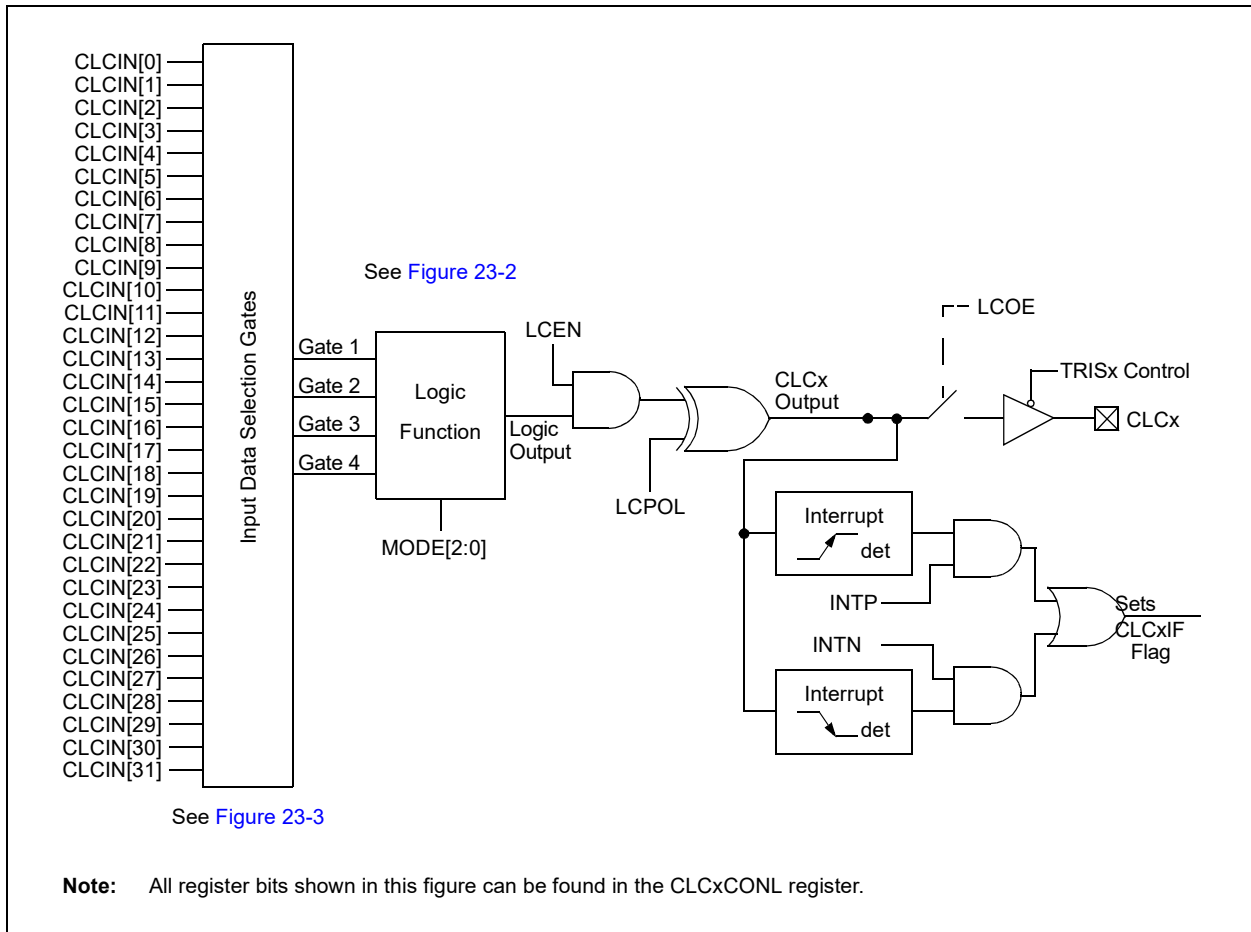

PIC24FJ256GA705 FAMILY

FIGURE 23-2: CLCx LOGIC FUNCTION COMBINATORIAL OPTIONS

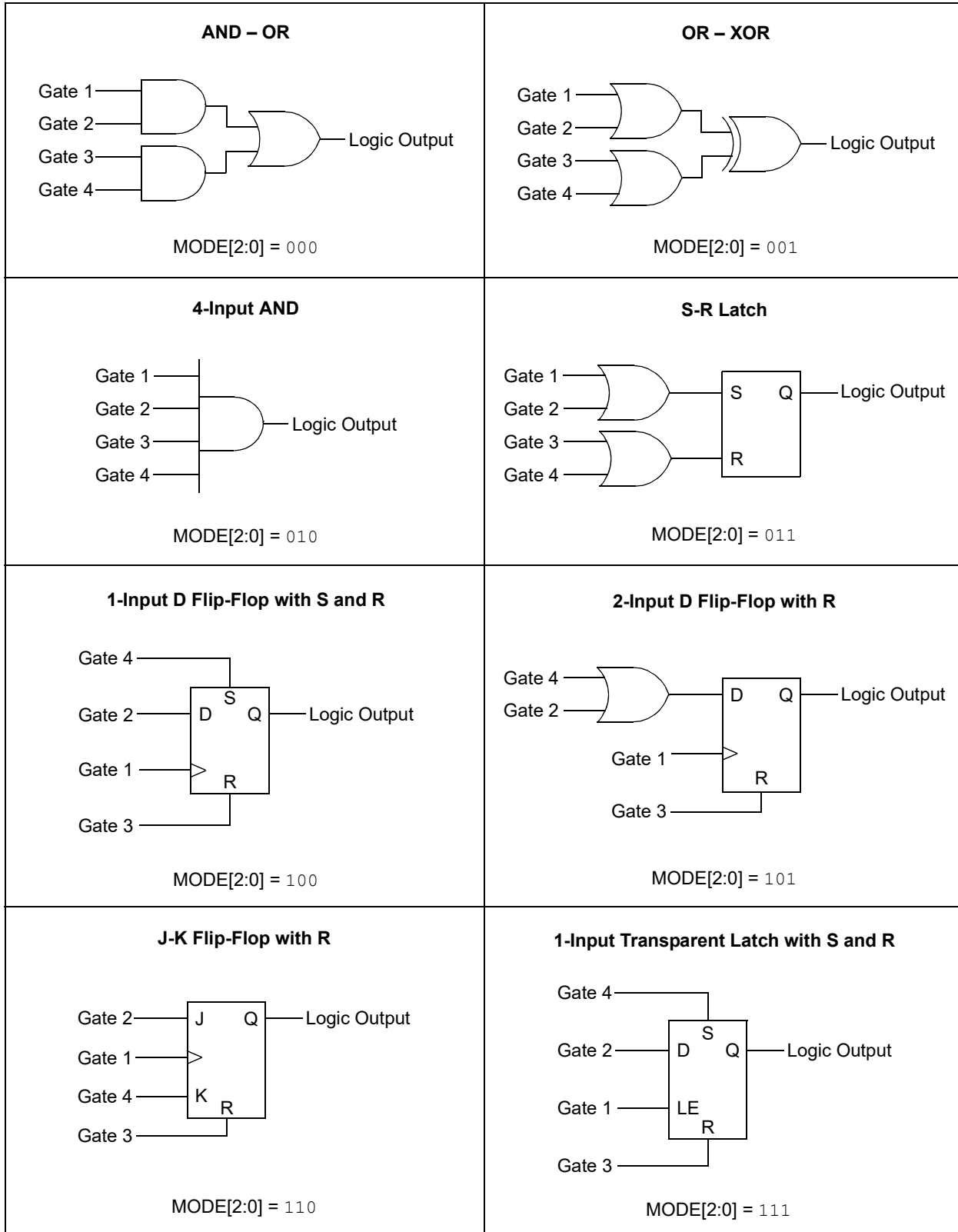
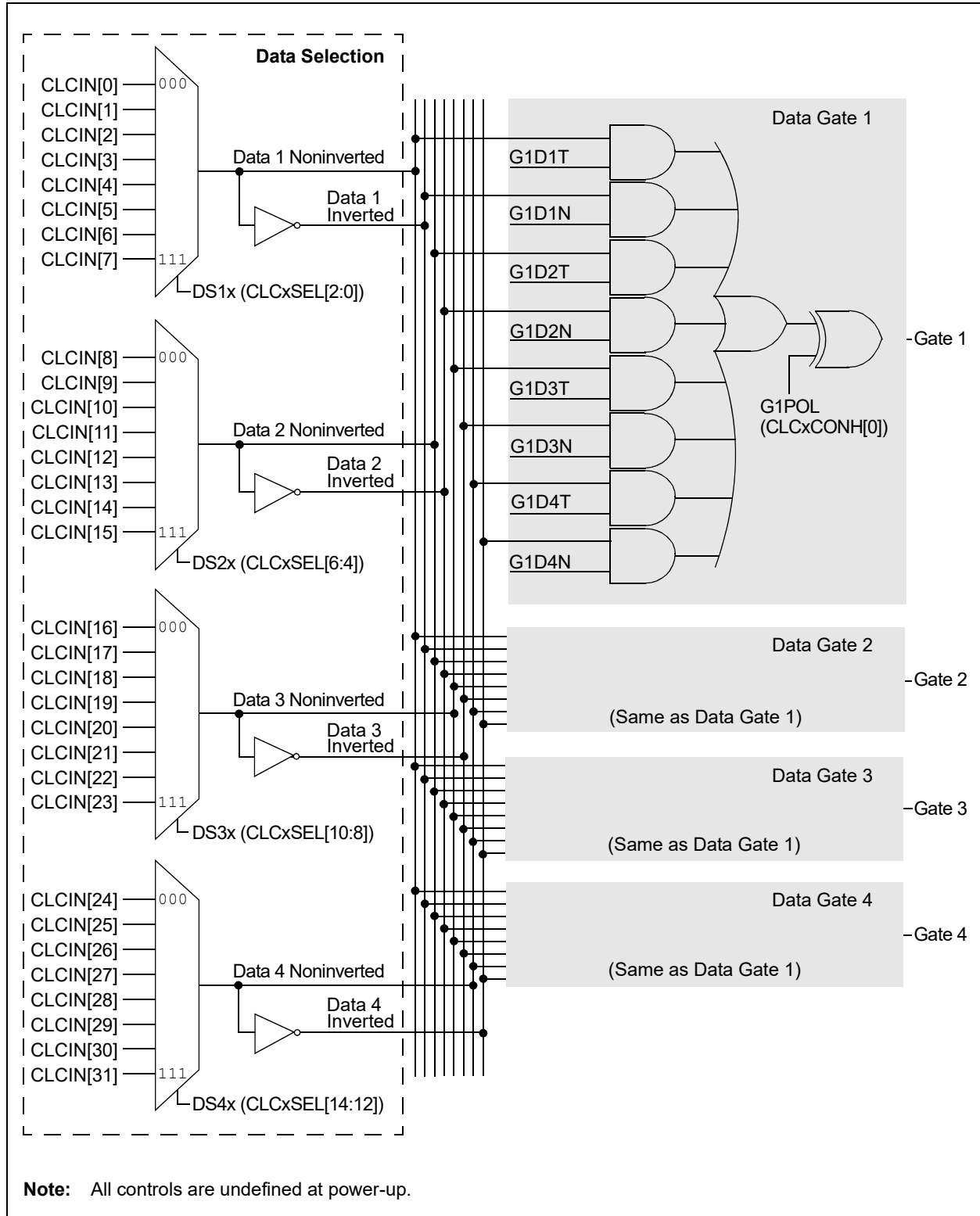

FIGURE 23-3: CLCx INPUT SOURCE SELECTION DIAGRAM



PIC24FJ256GA705 FAMILY

23.1 Control Registers

The CLCx module is controlled by the following registers:

- CLCxCONL
- CLCxCONH
- CLCxSEL
- CLCxGLSL
- CLCxGLSH

The CLCx Control registers (CLCxCONL and CLCxCONH) are used to enable the module and interrupts, control the output enable bit, select output polarity and select the logic function. The CLCx Control registers also allow the user to control the logic polarity of not only the cell output, but also some intermediate variables.

The CLCx Input MUX Select register (CLCxSEL) allows the user to select up to four data input sources using the four data input selection multiplexers. Each multiplexer has a list of eight data sources available.

The CLCx Gate Logic Input Select registers (CLCxGLSL and CLCxGLSH) allow the user to select which outputs from each of the selection MUXes are used as inputs to the input gates of the logic cell. Each data source MUX outputs both a true and a negated version of its output. All of these eight signals are enabled, ORed together by the logic cell input gates.

REGISTER 23-1: CLCxCONL: CLCx CONTROL REGISTER (LOW)

R/W-0	U-0	U-0	U-0	R/W-0	R/W-0	U-0	U-0
LCEN	—	—	—	INTP	INTN	—	—
bit 15						bit 8	

R/W-0	R-0	R/W-0	U-0	U-0	R/W-0	R/W-0	R/W-0
LCOE	LCOUT	LCPOL	—	—	MODE2	MODE1	MODE0
bit 7						bit 0	

Legend:

R = Readable bit	W = Writable bit	U = Unimplemented bit, read as '0'
-n = Value at POR	'1' = Bit is set	'0' = Bit is cleared
		x = Bit is unknown

- bit 15 **LCEN:** CLCx Enable bit
1 = CLCx is enabled and mixing input signals
0 = CLCx is disabled and has logic zero outputs
- bit 14-12 **Unimplemented:** Read as '0'
- bit 11 **INTP:** CLCx Positive Edge Interrupt Enable bit
1 = Interrupt will be generated when a rising edge occurs on LCOUT
0 = Interrupt will not be generated
- bit 10 **INTN:** CLCx Negative Edge Interrupt Enable bit
1 = Interrupt will be generated when a falling edge occurs on LCOUT
0 = Interrupt will not be generated
- bit 9-8 **Unimplemented:** Read as '0'
- bit 7 **LCOE:** CLCx Port Enable bit
1 = CLCx port pin output is enabled
0 = CLCx port pin output is disabled
- bit 6 **LCOUT:** CLCx Data Output Status bit
1 = CLCx output high
0 = CLCx output low
- bit 5 **LCPOL:** CLCx Output Polarity Control bit
1 = The output of the module is inverted
0 = The output of the module is not inverted
- bit 4-3 **Unimplemented:** Read as '0'

REGISTER 23-1: CLCxCONL: CLCx CONTROL REGISTER (LOW) (CONTINUED)

bit 2-0 **MODE[2:0]:** CLCx Mode bits
 111 = Cell is a 1-input transparent latch with S and R
 110 = Cell is a JK flip-flop with R
 101 = Cell is a 2-input D flip-flop with R
 100 = Cell is a 1-input D flip-flop with S and R
 011 = Cell is an SR latch
 010 = Cell is a 4-input AND
 001 = Cell is an OR-XOR
 000 = Cell is an AND-OR

REGISTER 23-2: CLCxCONH: CLCx CONTROL REGISTER (HIGH)

U-0	U-0	U-0	U-0	U-0	U-0	U-0	U-0
—	—	—	—	—	—	—	—
bit 15							bit 8

U-0	U-0	U-0	U-0	R/W-0	R/W-0	R/W-0	R/W-0
—	—	—	—	G4POL	G3POL	G2POL	G1POL
bit 7							bit 0

Legend:

R = Readable bit	W = Writable bit	U = Unimplemented bit, read as '0'
-n = Value at POR	'1' = Bit is set	'0' = Bit is cleared x = Bit is unknown

bit 15-4 **Unimplemented:** Read as '0'

bit 3 **G4POL:** Gate 4 Polarity Control bit
 1 = The output of Channel 4 logic is inverted when applied to the logic cell
 0 = The output of Channel 4 logic is not inverted

bit 2 **G3POL:** Gate 3 Polarity Control bit
 1 = The output of Channel 3 logic is inverted when applied to the logic cell
 0 = The output of Channel 3 logic is not inverted

bit 1 **G2POL:** Gate 2 Polarity Control bit
 1 = The output of Channel 2 logic is inverted when applied to the logic cell
 0 = The output of Channel 2 logic is not inverted

bit 0 **G1POL:** Gate 1 Polarity Control bit
 1 = The output of Channel 1 logic is inverted when applied to the logic cell
 0 = The output of Channel 1 logic is not inverted

PIC24FJ256GA705 FAMILY

REGISTER 23-3: CLCxSEL: CLCx INPUT MUX SELECT REGISTER

U-0	R/W-0	R/W-0	R/W-0	U-0	R/W-0	R/W-0	R/W-0
—	DS4[2:0]			—	DS3[2:0]		
bit 15				bit 8			

U-0	R/W-0	R/W-0	R/W-0	U-0	R/W-0	R/W-0	R/W-0
—	DS2[2:0]			—	DS1[2:0]		
bit 7				bit 0			

Legend:

R = Readable bit W = Writable bit U = Unimplemented bit, read as '0'
 -n = Value at POR '1' = Bit is set '0' = Bit is cleared x = Bit is unknown

- bit 15 **Unimplemented:** Read as '0'
- bit 14-12 **DS4[2:0]:** Data Selection MUX 4 Signal Selection bits
 111 = MCCP3 Compare Event Interrupt Flag (CCP3IF)
 110 = MCCP1 Compare Event Interrupt Flag (CCP1IF)
 101 = Unimplemented
 100 = CTMU A/D trigger
 011 = SPIx Input (SDIx) corresponding to the CLCx module (see [Table 23-1](#))
 010 = Comparator 3 output
 001 = Module-specific CLCx output (see [Table 23-1](#))
 000 = CLCINB I/O pin
- bit 11 **Unimplemented:** Read as '0'
- bit 10-8 **DS3[2:0]:** Data Selection MUX 3 Signal Selection bits
 111 = MCCP3 Compare Event Interrupt Flag (CCP3IF)
 110 = MCCP2 Compare Event Interrupt Flag (CCP2IF)
 101 = DMA Channel 1 interrupt
 100 = UARTx RX output corresponding to the CLCx module (see [Table 23-1](#))
 011 = SPIx Output (SDOx) corresponding to the CLCx module (see [Table 23-1](#))
 010 = Comparator 2 output
 001 = CLCx output (see [Table 23-1](#))
 000 = CLCINA I/O pin
- bit 7 **Unimplemented:** Read as '0'
- bit 6-4 **DS2[2:0]:** Data Selection MUX 2 Signal Selection bits
 111 = MCCP2 Compare Event Interrupt Flag (CCP2IF)
 110 = MCCP1 Compare Event Interrupt Flag (CCP1IF)
 101 = DMA Channel 0 interrupt
 100 = A/D conversion done interrupt
 011 = UARTx TX input corresponding to the CLCx module (see [Table 23-1](#))
 010 = Comparator 1 output
 001 = CLCx output (see [Table 23-1](#))
 000 = CLCINB I/O pin
- bit 3 **Unimplemented:** Read as '0'
- bit 2-0 **DS1[2:0]:** Data Selection MUX 1 Signal Selection bits
 111 = Timer3 match event
 110 = Timer2 match event
 101 = Unimplemented
 100 = REFO output
 011 = INTRC/LPRC clock source
 010 = SOSC clock source
 001 = System clock (TCY)
 000 = CLCINA I/O pin

TABLE 23-1: MODULE-SPECIFIC INPUT DATA SOURCES

Bit Field Value		Input Source	
		CLC1	CLC2
DS4[2:0]	011	SDI1	SDI2
	001	CLC2 Output	CLC1 Output
DS3[2:0]	100	U1RX	U2RX
	011	SDO1	SDO2
	001	CLC1 Output	CLC2 Output
DS2[2:0]	011	U1TX	U2TX
	001	CLC2 Output	CLC1 Output

REGISTER 23-4: CLCxGLSL: CLCx GATE LOGIC INPUT SELECT LOW REGISTER

R/W-0	R/W-0	R/W-0	R/W-0	R/W-0	R/W-0	R/W-0	R/W-0
G2D4T	G2D4N	G2D3T	G2D3N	G2D2T	G2D2N	G2D1T	G2D1N
bit 15						bit 8	

R/W-0	R/W-0	R/W-0	R/W-0	R/W-0	R/W-0	R/W-0	R/W-0
G1D4T	G1D4N	G1D3T	G1D3N	G1D2T	G1D2N	G1D1T	G1D1N
bit 7						bit 0	

Legend:

R = Readable bit W = Writable bit U = Unimplemented bit, read as '0'
 -n = Value at POR '1' = Bit is set '0' = Bit is cleared x = Bit is unknown

- bit 15 **G2D4T:** Gate 2 Data Source 4 True Enable bit
 1 = The Data Source 4 signal is enabled for Gate 2
 0 = The Data Source 4 signal is disabled for Gate 2
- bit 14 **G2D4N:** Gate 2 Data Source 4 Negated Enable bit
 1 = The Data Source 4 inverted signal is enabled for Gate 2
 0 = The Data Source 4 inverted signal is disabled for Gate 2
- bit 13 **G2D3T:** Gate 2 Data Source 3 True Enable bit
 1 = The Data Source 3 signal is enabled for Gate 2
 0 = The Data Source 3 signal is disabled for Gate 2
- bit 12 **G2D3N:** Gate 2 Data Source 3 Negated Enable bit
 1 = The Data Source 3 inverted signal is enabled for Gate 2
 0 = The Data Source 3 inverted signal is disabled for Gate 2
- bit 11 **G2D2T:** Gate 2 Data Source 2 True Enable bit
 1 = The Data Source 2 signal is enabled for Gate 2
 0 = The Data Source 2 signal is disabled for Gate 2
- bit 10 **G2D2N:** Gate 2 Data Source 2 Negated Enable bit
 1 = The Data Source 2 inverted signal is enabled for Gate 2
 0 = The Data Source 2 inverted signal is disabled for Gate 2
- bit 9 **G2D1T:** Gate 2 Data Source 1 True Enable bit
 1 = The Data Source 1 signal is enabled for Gate 2
 0 = The Data Source 1 signal is disabled for Gate 2

PIC24FJ256GA705 FAMILY

REGISTER 23-4: CLCxGLSL: CLCx GATE LOGIC INPUT SELECT LOW REGISTER (CONTINUED)

- bit 8 **G2D1N:** Gate 2 Data Source 1 Negated Enable bit
1 = The Data Source 1 inverted signal is enabled for Gate 2
0 = The Data Source 1 inverted signal is disabled for Gate 2
- bit 7 **G1D4T:** Gate 1 Data Source 4 True Enable bit
1 = The Data Source 4 signal is enabled for Gate 1
0 = The Data Source 4 signal is disabled for Gate 1
- bit 6 **G1D4N:** Gate 1 Data Source 4 Negated Enable bit
1 = The Data Source 4 inverted signal is enabled for Gate 1
0 = The Data Source 4 inverted signal is disabled for Gate 1
- bit 5 **G1D3T:** Gate 1 Data Source 3 True Enable bit
1 = The Data Source 3 signal is enabled for Gate 1
0 = The Data Source 3 signal is disabled for Gate 1
- bit 4 **G1D3N:** Gate 1 Data Source 3 Negated Enable bit
1 = The Data Source 3 inverted signal is enabled for Gate 1
0 = The Data Source 3 inverted signal is disabled for Gate 1
- bit 3 **G1D2T:** Gate 1 Data Source 2 True Enable bit
1 = The Data Source 2 signal is enabled for Gate 1
0 = The Data Source 2 signal is disabled for Gate 1
- bit 2 **G1D2N:** Gate 1 Data Source 2 Negated Enable bit
1 = The Data Source 2 inverted signal is enabled for Gate 1
0 = The Data Source 2 inverted signal is disabled for Gate 1
- bit 1 **G1D1T:** Gate 1 Data Source 1 True Enable bit
1 = The Data Source 1 signal is enabled for Gate 1
0 = The Data Source 1 signal is disabled for Gate 1
- bit 0 **G1D1N:** Gate 1 Data Source 1 Negated Enable bit
1 = The Data Source 1 inverted signal is enabled for Gate 1
0 = The Data Source 1 inverted signal is disabled for Gate 1

REGISTER 23-5: CLCxGLSH: CLCx GATE LOGIC INPUT SELECT HIGH REGISTER

R/W-0	R/W-0	R/W-0	R/W-0	R/W-0	R/W-0	R/W-0	R/W-0
G4D4T	G4D4N	G4D3T	G4D3N	G4D2T	G4D2N	G4D1T	G4D1N
bit 15							bit 8

R/W-0	R/W-0	R/W-0	R/W-0	R/W-0	R/W-0	R/W-0	R/W-0
G3D4T	G3D4N	G3D3T	G3D3N	G3D2T	G3D2N	G3D1T	G3D1N
bit 7							bit 0

Legend:

R = Readable bit	W = Writable bit	U = Unimplemented bit, read as '0'
-n = Value at POR	'1' = Bit is set	'0' = Bit is cleared
		x = Bit is unknown

- bit 15 **G4D4T:** Gate 4 Data Source 4 True Enable bit
1 = The Data Source 4 signal is enabled for Gate 4
0 = The Data Source 4 signal is disabled for Gate 4
- bit 14 **G4D4N:** Gate 4 Data Source 4 Negated Enable bit
1 = The Data Source 4 inverted signal is enabled for Gate 4
0 = The Data Source 4 inverted signal is disabled for Gate 4
- bit 13 **G4D3T:** Gate 4 Data Source 3 True Enable bit
1 = The Data Source 3 signal is enabled for Gate 4
0 = The Data Source 3 signal is disabled for Gate 4
- bit 12 **G4D3N:** Gate 4 Data Source 3 Negated Enable bit
1 = The Data Source 3 inverted signal is enabled for Gate 4
0 = The Data Source 3 inverted signal is disabled for Gate 4
- bit 11 **G4D2T:** Gate 4 Data Source 2 True Enable bit
1 = The Data Source 2 signal is enabled for Gate 4
0 = The Data Source 2 signal is disabled for Gate 4
- bit 10 **G4D2N:** Gate 4 Data Source 2 Negated Enable bit
1 = The Data Source 2 inverted signal is enabled for Gate 4
0 = The Data Source 2 inverted signal is disabled for Gate 4
- bit 9 **G4D1T:** Gate 4 Data Source 1 True Enable bit
1 = The Data Source 1 signal is enabled for Gate 4
0 = The Data Source 1 signal is disabled for Gate 4
- bit 8 **G4D1N:** Gate 4 Data Source 1 Negated Enable bit
1 = The Data Source 1 inverted signal is enabled for Gate 4
0 = The Data Source 1 inverted signal is disabled for Gate 4
- bit 7 **G3D4T:** Gate 3 Data Source 4 True Enable bit
1 = The Data Source 4 signal is enabled for Gate 3
0 = The Data Source 4 signal is disabled for Gate 3
- bit 6 **G3D4N:** Gate 3 Data Source 4 Negated Enable bit
1 = The Data Source 4 inverted signal is enabled for Gate 3
0 = The Data Source 4 inverted signal is disabled for Gate 3
- bit 5 **G3D3T:** Gate 3 Data Source 3 True Enable bit
1 = The Data Source 3 signal is enabled for Gate 3
0 = The Data Source 3 signal is disabled for Gate 3
- bit 4 **G3D3N:** Gate 3 Data Source 3 Negated Enable bit
1 = The Data Source 3 inverted signal is enabled for Gate 3
0 = The Data Source 3 inverted signal is disabled for Gate 3

PIC24FJ256GA705 FAMILY

REGISTER 23-5: CLCxGLSH: CLCx GATE LOGIC INPUT SELECT HIGH REGISTER (CONTINUED)

- bit 3 **G3D2T:** Gate 3 Data Source 2 True Enable bit
1 = The Data Source 2 signal is enabled for Gate 3
0 = The Data Source 2 signal is disabled for Gate 3
- bit 2 **G3D2N:** Gate 3 Data Source 2 Negated Enable bit
1 = The Data Source 2 inverted signal is enabled for Gate 3
0 = The Data Source 2 inverted signal is disabled for Gate 3
- bit 1 **G3D1T:** Gate 3 Data Source 1 True Enable bit
1 = The Data Source 1 signal is enabled for Gate 3
0 = The Data Source 1 signal is disabled for Gate 3
- bit 0 **G3D1N:** Gate 3 Data Source 1 Negated Enable bit
1 = The Data Source 1 inverted signal is enabled for Gate 3
0 = The Data Source 1 inverted signal is disabled for Gate 3

24.0 12-BIT A/D CONVERTER WITH THRESHOLD DETECT

Note: This data sheet summarizes the features of this group of PIC24F devices. It is not intended to be a comprehensive reference source. For more information on the 12-Bit A/D Converter, refer to “12-Bit A/D Converter with Threshold Detect” (www.microchip.com/DS39739) in the “dsPIC33/PIC24 Family Reference Manual”. The information in this data sheet supersedes the information in the FRM.

The A/D Converter has the following key features:

- Successive Approximation Register (SAR) Conversion
- Selectable 10-Bit or 12-Bit (default) Conversion Resolution
- Conversion Speeds of up to 200 ksps (12-bit)
- Up to 19 Analog Input Channels (internal and external)
- Multiple Internal Reference Input Channels
- External Voltage Reference Input Pins
- Unipolar Differential Sample-and-Hold (S/H) Amplifier
- Automated Threshold Scan and Compare Operation to Pre-Evaluate Conversion Results
- Selectable Conversion Trigger Source
- Fixed Length (one word per channel), Configurable Conversion Result Buffer
- Four Options for Results Alignment
- Configurable Interrupt Generation
- Enhanced DMA Operations with Indirect Address Generation
- Operation During CPU Sleep and Idle modes

The 12-bit A/D Converter module is an enhanced version of the 10-bit module offered in earlier PIC24 devices. It is a Successive Approximation Register (SAR) Converter, enhanced with 12-bit resolution, a wide range of automatic sampling options, tighter integration with other analog modules and a configurable results buffer.

It also includes a unique Threshold Detect feature that allows the module itself to make simple decisions based on the conversion results, and enhanced operation with the DMA Controller through Peripheral Indirect Addressing (PIA).

A simplified block diagram for the module is shown in [Figure 24-1](#).

24.1 Basic Operation

To perform a standard A/D conversion:

1. Configure the module:
 - a) Configure port pins as analog inputs by setting the appropriate bits in the ANSx registers (see [Section 11.2 “Configuring Analog Port Pins \(ANSx\)”](#) for more information).
 - b) Select the voltage reference source to match the expected range on analog inputs (AD1CON2[15:13]).
 - c) Select the positive and negative multiplexer inputs for each channel (AD1CHS[15:0]).
 - d) Select the analog conversion clock to match the desired data rate with the processor clock (AD1CON3[7:0]).
 - e) Select the appropriate sample/conversion sequence (AD1CON1[7:4] and AD1CON3[12:8]).
 - f) For Channel A scanning operations, select the positive channels to be included (AD1CSSH and AD1CSSL registers).
 - g) Select how conversion results are presented in the buffer (AD1CON1[9:8] and AD1CON5 register).
 - h) Select the interrupt rate (AD1CON2[5:2]).
 - i) Turn on A/D module (AD1CON1[15]).
2. Configure the A/D interrupt (if required):
 - a) Clear the AD1IF bit (IFS0[13]).
 - b) Enable the AD1IE interrupt (IEC0[13]).
 - c) Select the A/D interrupt priority (IPC3[6:4]).
3. If the module is configured for manual sampling, set the SAMP bit (AD1CON1[1]) to begin sampling.

24.2 Extended DMA Operations

In addition to the standard features available on all 12-bit A/D Converters, PIC24FJ256GA705 family devices implement a limited extension of DMA functionality. This extension adds features that work with the device's DMA Controller to expand the A/D module's data storage abilities beyond the module's built-in buffer.

The Extended DMA functionality is controlled by the DMAEN bit (AD1CON1[11]); setting this bit enables the functionality. The DMABM bit (AD1CON1[12]) configures how the DMA feature operates.

24.2.1 EXTENDED BUFFER MODE

Extended Buffer mode (DMABM = 1) maps the A/D Data Buffer registers and data from all channels above 13 into a user-specified area of data RAM. This allows users to read the conversion results of channels above 13, which do not have their own memory-mapped A/D buffer locations, from data memory.

To accomplish this, the DMA must be configured in Peripheral Indirect Addressing mode and the DMA destination address must point to the beginning of the buffer. The DMA count must be set to generate an interrupt after the desired number of conversions.

In Extended Buffer mode, the A/D control bits will function similarly to non-DMA modes. The BUFREGEN bit will still select between FIFO mode and Channel-Aligned mode, but the number of words in the destination FIFO will be determined by the SMP1x[4:0] bits in DMA mode. In FIFO mode, the BUFM bit will still split the output FIFO into two sets of 13 results (the SMP1x bits should be set accordingly) and the BUFS bit will still indicate which set of results is being written to and which can be read.

24.2.2 PIA MODE

When DMABM = 0, the A/D module is configured to function with the DMA Controller for Peripheral Indirect Addressing (PIA) mode operations. In this mode, the A/D module generates an 11-bit Indirect Address (IA). This is ORed with the destination address in the DMA Controller to define where the A/D conversion data will be stored.

In PIA mode, the buffer space is created as a series of contiguous smaller buffers, one per analog channel. The size of the channel buffer determines how many analog channels can be accommodated. The size of the buffer is selected by the DMABL[2:0] bits (AD1CON4[2:0]). The size options range from a single word per buffer to 128 words. Each channel is allocated a buffer of this size, regardless of whether or not the channel will actually have conversion data.

The IA is created by combining the base address within a channel buffer with three to five bits (depending on the buffer size) to identify the channel. The base address ranges from zero to seven bits wide, depending on the buffer size. The address is right-padded with a '0' in order to maintain address alignment in the Data Space. The concatenated channel and base address bits are then left-padded with zeros, as necessary, to complete the 11-bit IA.

The IA is configured to auto-increment which channel is written in each analog input's sub-buffer during write operations by using the SMP1x bits (AD1CON2[6:2]).

As with PIA operations for any DMA-enabled module, the base destination address in the DMADSTn register must be masked properly to accommodate the IA. [Table 24-1](#) shows how complete addresses are formed. Note that the address masking varies for each buffer size option. Because of masking requirements, some address ranges may not be available for certain buffer sizes. Users should verify that the DMA base address is compatible with the buffer size selected.

[Figure 24-2](#) shows how the parts of the address define the buffer locations in data memory. In this case, the module "allocates" 256 bytes of data RAM (1000h to 1100h) for 32 buffers of four words each. However, this is not a hard allocation and nothing prevents these locations from being used for other purposes. For example, in the current case, if Analog Channels 1, 3 and 8 are being sampled and converted, conversion data will only be written to the channel buffers, starting at 1008h, 1018h and 1040h. The holes in the PIA buffer space can be used for any other purpose. It is the user's responsibility to keep track of buffer locations and prevent data overwrites.

PIC24FJ256GA705 FAMILY

24.3 Registers

The 12-bit A/D Converter is controlled through a total of 13 registers:

- AD1CON1 through AD1CON5 (Register 24-1 through Register 24-5)
- AD1CHS (Register 24-6)
- ANCFG (Register 24-7)
- AD1CHITL (Register 24-8)
- AD1CSSH and AD1CSSL (Register 24-9 and Register 24-10)
- AD1CTMENH and AD1CTMENL (Register 24-11 and Register 24-12)
- AD1DMBUF (not shown) – The 16-bit conversion buffer for Extended Buffer mode

TABLE 24-1: INDIRECT ADDRESS GENERATION IN PIA MODE

DMABL[2:0]	Buffer Size per Channel (words)	Generated Offset Address (lower 11 bits)	Available Input Channels	Allowable DMADSTn Addresses
000	1	000 00cc ccc0	32	xxxx xxxx xx00 0000
001	2	000 0ccc ccn0	32	xxxx xxxx x000 0000
010	4	000 cccc cnn0	32	xxxx xxxx 0000 0000
011	8	00c cccc nnn0	32	xxxx xxx0 0000 0000
100	16	0cc cccn nnn0	32	xxxx xx00 0000 0000
101	32	ccc ccnn nnn0	32	xxxx x000 0000 0000
110	64	ccc cnnn nnn0	16	xxxx x000 0000 0000
111	128	ccc nnnn nnn0	8	xxxx x000 0000 0000

Legend: ccc = Channel number (three to five bits), n = Base buffer address (zero to seven bits),
 x = User-definable range of DMADSTn for base address, 0 = Masked bits of DMADSTn for IA

24.4 Achieving Maximum A/D Converter Performance

In order to get the shortest overall conversion time (called the 'throughput') while maintaining accuracy, several factors must be considered. These are described in detail below.

- Dependence of AVDD – If the AVDD supply is < 2.7V, the Charge Pump Enable bit (PUMPEN, AD1CON3[13]) should be set to '1'. The input channel multiplexer has a varying resistance with AVDD (the lower AVDD, the higher the internal switch resistance). The charge pump provides a higher internal AVDD to keep the switch resistance as low as possible.
- Dependence on TAD – The ADC timing is driven by TAD, not TCYC. Selecting the TAD time correctly is critical to getting the best ADC throughput. It is important to note that the overall ADC throughput is not simply the 'Conversion Time' of the SAR. It is the combination of the Conversion Time, the Sample Time and additional TAD delays for internal synchronization logic.
- Relationship between TCYC and TAD – There is not a fixed 1:1 timing relationship between TCYC and TAD. The fastest possible throughput is fundamentally set by TAD (min), not by TCYC. The TAD time is set as a programmable integer multiple of TCYC by the ADCS[7:0] bits. Referring to Table 32-35, the TAD (min) time is greater than the 4 MHz period of the dedicated ADC RC clock generator. Therefore, TAD must be two TCYC in order to use the RC clock for fastest throughput. The TAD (min) is a multiple of 3.597 MHz as opposed to 4 MHz. To run as fast as possible, TCYC must be a multiple of TAD (min) because values of ADCSx are integers. For example, if a standard 'color burst' crystal of 14.31818 MHz is used, TCYC is 279.4 ns, which is very close to TAD (min) and the ADC throughput is optimal. Running at 16 MHz will actually reduce the throughput, because TAD will have to be 500 ns as the TCYC of 250 ns violates TAD (min).

- Dependence on driving Source Resistance (Rs) – Certain transducers have high output impedance (> 2.5 kΩ). Having a high Rs will require longer sampling time to charge the S/H cap through the resistance path (see Figure 25-3). The worst case is a full-range voltage step of AVSS to AVDD with the sampling cap at AVSS. The capacitor time constant is (RS + RIC + RSS) (CHOLD) and the sample time needs to be six time constants minimum (eight are preferred). Since the ADC logic timing is TAD-based, the sample time (in TAD) must be long enough, over all conditions, to charge/discharge CHOLD. Do not assume one TAD is sufficient sample time; longer times may be required to achieve the accuracy needed by the application. The value of CHOLD is 40 pF.

A small amount of charge is present at the ADC input pin when the sample switch is closed. If Rs is high, this will generate a DC error exceeding one LSB. Keeping Rs < 50Ω is recommended for best results. The error can also be reduced by increasing sample time (a 2 kΩ value of Rs requires a 3 μS sample time to eliminate the error).

- Calculating Throughput – The throughput of the ADC is based on TAD. The throughput is given by:

$$\text{Throughput} = 1/(\text{Sample Time} + \text{SAR Conversion Time} + \text{Clock Sync Time})$$

where:

Sample Time is the calculated TAD periods for the application. SAR Conversion Time is 12 TAD for 10-bit and 14 TAD for 12-bit conversions. Clock Sync Time is 2.5 TAD (worst case).

Example: For a 12-bit ADC throughput, if using FRC = 8 MHz and the Sample Time is one TAD, the use of an 8 MHz FRC means the TCYC = 250 ns and this requires: TAD = 2 TCYC = 500 ns. Therefore, the throughput is:

$$\text{Throughput} = 1/(500 \text{ ns}) + (14 * 500 \text{ ns}) + (2.5 * 500 \text{ ns}) = 114.28 \text{ KS/sec}$$

Note that the clock sync delay could be as little as 1.5 TAD, which could produce 121 KS/sec, but that cannot be ensured as the timing relationship is asynchronous and not specified. The worst case timing of 2.5 TAD should be used to calculate throughput.

Example: A certain transducer has a 20 kΩ output impedance. If AVDD is 3.0, the maximum sample time needed would be determined by the following:

$$\begin{aligned} \text{Sample Time} &= 6 * (RS + RIC + RSS) * CHOLD \\ &= 6 * (20K + 250 + 350) * 40 \text{ pF} \\ &= 4.95 \text{ } \mu\text{S} \end{aligned}$$

If TAD = 500 ns, this requires a Sample Time of 4.95 μS/500 ns = 10 TAD (for a full-step voltage on the transducer output). RSS is 350Ω because AVDD is above 2.7V.

PIC24FJ256GA705 FAMILY

FIGURE 24-2: EXAMPLE OF BUFFER ADDRESS GENERATION IN PIA MODE (4-WORD BUFFERS PER CHANNEL)

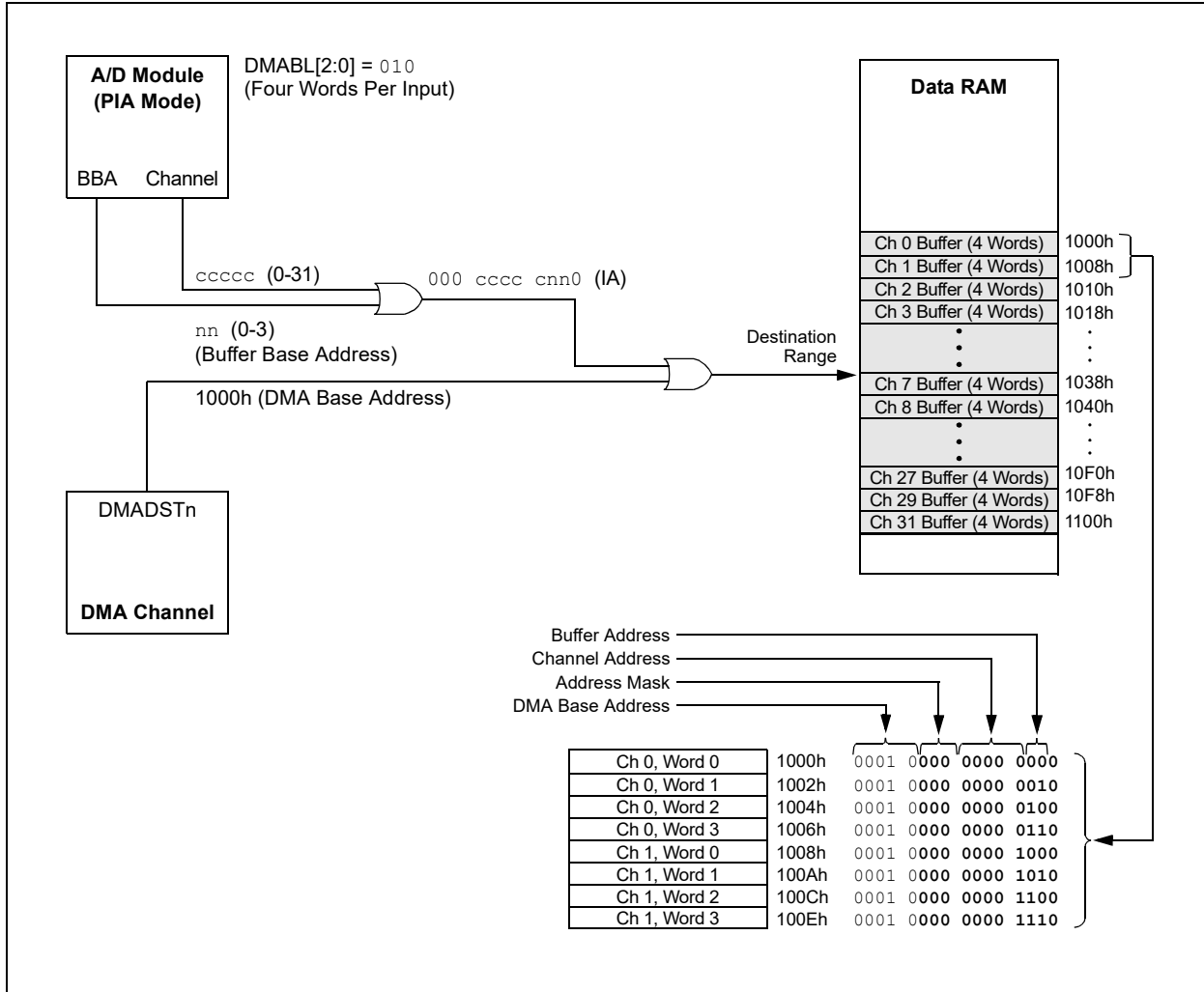

PIC24FJ256GA705 FAMILY

REGISTER 24-1: AD1CON1: A/D CONTROL REGISTER 1

R/W-0	U-0	R/W-0	R/W-0	R/W-0	R/W-0	R/W-0	R/W-0
ADON	—	ADSIDL	DMABM ⁽¹⁾	DMAEN	MODE12	FORM1	FORM0
bit 15							bit 8

R/W-0	R/W-0	R/W-0	R/W-0	U-0	R/W-0	HSC/R/W-0	HSC/R/C-0
SSRC3	SSRC2	SSRC1	SSRC0	—	ASAM	SAMP	DONE
bit 7							bit 0

Legend:	C = Clearable bit	U = Unimplemented bit, read as '0'
R = Readable bit	W = Writable bit	HSC = Hardware Settable/Clearable bit
-n = Value at POR	'1' = Bit is set	'0' = Bit is cleared
		x = Bit is unknown

- bit 15 **ADON:** A/D Operating Mode bit
1 = A/D Converter is operating
0 = A/D Converter is off
- bit 14 **Unimplemented:** Read as '0'
- bit 13 **ADSIDL:** A/D Stop in Idle Mode bit
1 = Discontinues module operation when device enters Idle mode
0 = Continues module operation in Idle mode
- bit 12 **DMABM:** Extended DMA Buffer Mode Select bit⁽¹⁾
1 = Extended Buffer mode: Buffer address is defined by the DMADSTn register
0 = PIA mode: Buffer addresses are defined by the DMA Controller and AD1CON4[2:0]
- bit 11 **DMAEN:** Extended DMA/Buffer Enable bit
1 = Extended DMA and buffer features are enabled
0 = Extended features are disabled
- bit 10 **MODE12:** A/D 12-Bit Operation Mode bit
1 = 12-bit A/D operation
0 = 10-bit A/D operation
- bit 9-8 **FORM[1:0]:** Data Output Format bits (see formats following)
11 = Fractional result, signed, left justified
10 = Absolute fractional result, unsigned, left justified
01 = Decimal result, signed, right justified
00 = Absolute decimal result, unsigned, right justified
- bit 7-4 **SSRC[3:0]:** Sample Clock Source Select bits
0000 = SAMP is cleared by software
0001 = INT0
0010 = Timer3
0100 = CTMU trigger
0101 = Timer1 (will not trigger during Sleep mode)
0110 = Timer1 (may trigger during Sleep mode)
0111 = Auto-Convert mode
- bit 3 **Unimplemented:** Read as '0'
- bit 2 **ASAM:** A/D Sample Auto-Start bit
1 = Sampling begins immediately after last conversion; SAMP bit is auto-set
0 = Sampling begins when SAMP bit is manually set

Note 1: This bit is only available when Extended DMA and buffer features are available (DMAEN = 1).

PIC24FJ256GA705 FAMILY

REGISTER 24-1: AD1CON1: A/D CONTROL REGISTER 1 (CONTINUED)

- bit 1 **SAMP:** A/D Sample Enable bit
 1 = A/D Sample-and-Hold amplifiers are sampling
 0 = A/D Sample-and-Hold amplifiers are holding
- bit 0 **DONE:** A/D Conversion Status bit
 1 = A/D conversion cycle has completed
 0 = A/D conversion cycle has not started or is in progress

Note 1: This bit is only available when Extended DMA and buffer features are available (DMAEN = 1).

REGISTER 24-2: AD1CON2: A/D CONTROL REGISTER 2

R/W-0	R/W-0	R/W-0	r-0	R/W-0	R/W-0	U-0	U-0
PVCFG1	PVCFG0	NVCFG0	—	BUFREGEN	CSCNA	—	—
bit 15						bit 8	

R-0	R/W-0	R/W-0	R/W-0	R/W-0	R/W-0	R/W-0	R/W-0
BUFS	SMPI4	SMPI3	SMPI2	SMPI1	SMPI0	BUFM	ALTS
bit 7						bit 0	

Legend:	r = Reserved bit	U = Unimplemented bit, read as '0'
R = Readable bit	W = Writable bit	'0' = Bit is cleared
-n = Value at POR	'1' = Bit is set	x = Bit is unknown

bit 15-14 **PVCFG[1:0]:** A/D Converter Positive Voltage Reference Configuration bits

- 1x = Unimplemented, do not use
- 01 = External VREF+
- 00 = AVDD

bit 13 **NVCFG0:** A/D Converter Negative Voltage Reference Configuration bit

- 1 = External VREF-
- 0 = AVSS

bit 12 **Reserved:** Maintain as '0'

bit 11 **BUFREGEN:** A/D Buffer Register Enable bit

- 1 = Conversion result is loaded into the buffer location determined by the converted channel
- 0 = A/D result buffer is treated as a FIFO

bit 10 **CSCNA:** Scan Input Selections for CH0+ During Sample A bit

- 1 = Scans inputs
- 0 = Does not scan inputs

bit 9-8 **Unimplemented:** Read as '0'

bit 7 **BUFS:** Buffer Fill Status bit

When DMAEN = 1 and DMABM = 1:

- 1 = A/D is currently filling the destination buffer from [buffer start + (buffer size/2)] to [buffer start + (buffer size - 1)]. User should access data located from [buffer start] to [buffer start + (buffer size/2) - 1].
- 0 = A/D is currently filling the destination buffer from [buffer start] to [buffer start + (buffer size/2) - 1]. User should access data located from [buffer start + (buffer size/2)] to [buffer start + (buffer size - 1)].

When DMAEN = 0:

- 1 = A/D is currently filling ADC1BUF13-ADC1BUF25, user should access data in ADC1BUF0-ADC1BUF12
- 0 = A/D is currently filling ADC1BUF0-ADC1BUF12, user should access data in ADC1BUF13-ADC1BUF25

PIC24FJ256GA705 FAMILY

REGISTER 24-2: AD1CON2: A/D CONTROL REGISTER 2 (CONTINUED)

- bit 6-2 **SMPI[4:0]:** Interrupt Sample/DMA Increment Rate Select bits
- When DMAEN = 1 and DMABM = 0:
 11111 = Increments the DMA address after completion of the 32nd sample/conversion operation
 11110 = Increments the DMA address after completion of the 31st sample/conversion operation
 •
 •
 •
 00001 = Increments the DMA address after completion of the 2nd sample/conversion operation
 00000 = Increments the DMA address after completion of each sample/conversion operation
- When DMAEN = 1 and DMABM = 1:
 11111 = Resets the DMA offset after completion of the 32nd sample/conversion operation
 11110 = Resets the DMA offset after completion of the 31nd sample/conversion operation
 •
 •
 •
 00001 = Resets the DMA offset after completion of the 2nd sample/conversion operation
 00000 = Resets the DMA offset after completion of every sample/conversion operation
- When DMAEN = 0:
 11111 = Interrupts at the completion of the conversion for each 32nd sample
 11110 = Interrupts at the completion of the conversion for each 31st sample
 •
 •
 •
 00001 = Interrupts at the completion of the conversion for every other sample
 00000 = Interrupts at the completion of the conversion for each sample
- bit 1 **BUFM:** Buffer Fill Mode Select bit
- 1 = Starts buffer filling at ADC1BUF0 on first interrupt and ADC1BUF13 on next interrupt
 0 = Always starts filling buffer at ADC1BUF0
- bit 0 **ALTS:** Alternate Input Sample Mode Select bit
- 1 = Uses channel input selects for Sample A on first sample and Sample B on next sample
 0 = Always uses channel input selects for Sample A

REGISTER 24-3: AD1CON3: A/D CONTROL REGISTER 3

R/W-0	R-0	R/W-0	R/W-0	R/W-0	R/W-0	R/W-0	R/W-0
ADRC ⁽¹⁾	EXTSAM	PUMPEN ⁽²⁾	SAMC4	SAMC3	SAMC2	SAMC1	SAMC0
bit 15							bit 8

R/W-0	R/W-0	R/W-0	R/W-0	R/W-0	R/W-0	R/W-0	R/W-0
ADCS[7:0]							
bit 7							bit 0

Legend:

R = Readable bit	W = Writable bit	U = Unimplemented bit, read as '0'
-n = Value at POR	'1' = Bit is set	'0' = Bit is cleared x = Bit is unknown

- bit 15 **ADRC:** A/D Conversion Clock Source bit⁽¹⁾
 1 = Dedicated ADC RC clock generator (4 MHz nominal).
 0 = Clock derived from system clock
- bit 14 **EXTSAM:** Extended Sampling Time bit
 1 = A/D is still sampling after SAMP = 0
 0 = A/D is finished sampling
- bit 13 **PUMPEN:** Charge Pump Enable bit⁽²⁾
 1 = Charge pump for switches is enabled
 0 = Charge pump for switches is disabled
- bit 12-8 **SAMC[4:0]:** Auto-Sample Time Select bits
 11111 = 31 TAD
 •
 •
 •
 00001 = 1 TAD
 00000 = 0 TAD
- bit 7-0 **ADCS[7:0]:** A/D Conversion Clock Select bits
 11111111 = 256 • TCY = TAD
 •
 •
 •
 00000001 = 2 • TCY = TAD
 00000000 = TCY = TAD

- Note 1:** Selecting the internal ADC RC clock requires that ADCSx be one or greater. Setting ADCSx = 0 when ADRC = 1 will violate the TAD (min) specification.
- Note 2:** The user should enable the charge pump if AVDD is < 2.7 V. Longer sample times are required due to the increase of the internal resistance of the MUX if the charge pump is disabled.

PIC24FJ256GA705 FAMILY

REGISTER 24-4: AD1CON4: A/D CONTROL REGISTER 4

U-0	U-0	U-0	U-0	U-0	U-0	U-0	U-0
—	—	—	—	—	—	—	—
bit 15							bit 8

U-0	U-0	U-0	U-0	U-0	R/W-0	R/W-0	R/W-0
—	—	—	—	—	DMABL[2:0] ⁽¹⁾		
bit 7						bit 0	

Legend:

R = Readable bit W = Writable bit U = Unimplemented bit, read as '0'
 -n = Value at POR '1' = Bit is set '0' = Bit is cleared x = Bit is unknown

bit 15-3 **Unimplemented:** Read as '0'

bit 2-0 **DMABL[2:0]:** DMA Buffer Size Select bits⁽¹⁾

- 111 = Allocates 128 words of buffer to each analog input
- 110 = Allocates 64 words of buffer to each analog input
- 101 = Allocates 32 words of buffer to each analog input
- 100 = Allocates 16 words of buffer to each analog input
- 011 = Allocates 8 words of buffer to each analog input
- 010 = Allocates 4 words of buffer to each analog input
- 001 = Allocates 2 words of buffer to each analog input
- 000 = Allocates 1 word of buffer to each analog input

Note 1: The DMABL[2:0] bits are only used when AD1CON1[11] = 1 and AD1CON1[12] = 0; otherwise, their value is ignored.

REGISTER 24-5: AD1CON5: A/D CONTROL REGISTER 5

R/W-0	R/W-0	R/W-0	R/W-0	U-0	U-0	R/W-0	R/W-0
ASEN	LPEN	CTMREQ	BGREQ	—	—	ASINT1	ASINT0
bit 15						bit 8	

U-0	U-0	U-0	U-0	R/W-0	R/W-0	R/W-0	R/W-0
—	—	—	—	WM1	WM0	CM1	CM0
bit 7						bit 0	

Legend:			
R = Readable bit	W = Writable bit	U = Unimplemented bit, read as '0'	
-n = Value at POR	'1' = Bit is set	'0' = Bit is cleared	x = Bit is unknown

- bit 15 **ASEN:** Auto-Scan Enable bit
1 = Auto-scan is enabled
0 = Auto-scan is disabled
- bit 14 **LPEN:** Low-Power Enable bit
1 = Low power is enabled after scan
0 = Full power is enabled after scan
- bit 13 **CTMREQ:** CTMU Request bit
1 = CTMU is enabled when the A/D is enabled and active
0 = CTMU is not enabled by the A/D
- bit 12 **BGREQ:** Band Gap Request bit
1 = Band gap is enabled when the A/D is enabled and active
0 = Band gap is not enabled by the A/D
- bit 11-10 **Unimplemented:** Read as '0'
- bit 9-8 **ASINT[1:0]:** Auto-Scan (Threshold Detect) Interrupt Mode bits
11 = Interrupt after Threshold Detect sequence has completed and valid compare has occurred
10 = Interrupt after valid compare has occurred
01 = Interrupt after Threshold Detect sequence has completed
00 = No interrupt
- bit 7-4 **Unimplemented:** Read as '0'
- bit 3-2 **WM[1:0]:** Write Mode bits
11 = Reserved
10 = Auto-compare only (conversion results are not saved, but interrupts are generated when a valid match occurs, as defined by the CMx and ASINTx bits)
01 = Convert and save (conversion results are saved to locations as determined by the register bits when a match occurs, as defined by the CMx bits)
00 = Legacy operation (conversion data are saved to a location determined by the Buffer register bits)
- bit 1-0 **CM[1:0]:** Compare Mode bits
11 = Outside Window mode: Valid match occurs if the conversion result is outside of the window defined by the corresponding buffer pair
10 = Inside Window mode: Valid match occurs if the conversion result is inside the window defined by the corresponding buffer pair
01 = Greater Than mode: Valid match occurs if the result is greater than the value in the corresponding Buffer register
00 = Less Than mode: Valid match occurs if the result is less than the value in the corresponding Buffer register

PIC24FJ256GA705 FAMILY

REGISTER 24-6: AD1CHS: A/D SAMPLE SELECT REGISTER

R/W-0	R/W-0	R/W-0	R/W-0	R/W-0	R/W-0	R/W-0	R/W-0
CH0NB2	CH0NB1	CH0NB0	CH0SB4	CH0SB3	CH0SB2	CH0SB1	CH0SB0
bit 15							bit 8

R/W-0	R/W-0	R/W-0	R/W-0	R/W-0	R/W-0	R/W-0	R/W-0
CH0NA2	CH0NA1	CH0NA0	CH0SA4	CH0SA3	CH0SA2	CH0SA1	CH0SA0
bit 7							bit 0

Legend:

R = Readable bit

W = Writable bit

U = Unimplemented bit, read as '0'

-n = Value at POR

'1' = Bit is set

'0' = Bit is cleared

x = Bit is unknown

bit 15-13 **CH0NB[2:0]:** Sample B Channel 0 Negative Input Select bits

1xx = Unimplemented

01x = Unimplemented

001 = Unimplemented

000 = AVss

bit 12-8 **CH0SB[4:0]:** Sample B Channel 0 Positive Input Select bits

11110 = AVDD⁽¹⁾

11101 = AVss⁽¹⁾

11100 = Band Gap Reference (V_{BG})⁽¹⁾

10000-11011 = Reserved

01111 = No external channels connected (used for CTMU)

01110 = No external channels connected (used for CTMU temperature sensor)

01101 = AN13

01100 = AN12

01011 = AN11

01010 = AN10

01001 = AN9

01000 = AN8

00111 = AN7

00110 = AN6

00101 = AN5

00100 = AN4

00011 = AN3

00010 = AN2

00001 = AN1

00000 = AN0

bit 7-5 **CH0NA[2:0]:** Sample A Channel 0 Negative Input Select bits

Same definitions as for CH0NB[2:0].

bit 4-0 **CH0SA[4:0]:** Sample A Channel 0 Positive Input Select bits

Same definitions as for CH0SB[4:0].

Note 1: These input channels do not have corresponding memory-mapped result buffers.

PIC24FJ256GA705 FAMILY

REGISTER 24-7: ANCFG: A/D BAND GAP REFERENCE CONFIGURATION REGISTER

U-0	U-0	U-0	U-0	U-0	U-0	U-0	U-0
—	—	—	—	—	—	—	—
bit 15							bit 8

U-0	U-0	U-0	U-0	U-0	R/W-0	R/W-0	R/W-0
—	—	—	—	—	VBGEN3 ⁽¹⁾	VBGEN2 ⁽¹⁾	VBGEN1 ⁽¹⁾
bit 7					bit 0		

Legend:

R = Readable bit

W = Writable bit

U = Unimplemented bit, read as '0'

-n = Value at POR

'1' = Bit is set

'0' = Bit is cleared

x = Bit is unknown

bit 15-3 **Unimplemented:** Read as '0'

bit 2 **VBGEN3:** A/D Band Gap Reference Enable bit⁽¹⁾

1 = Band gap reference is enabled

0 = Band gap reference is disabled

bit 1 **VBGEN2:** CTMU and Comparator Band Gap Reference Enable bit⁽¹⁾

1 = Band gap reference is enabled

0 = Band gap reference is disabled

bit 0 **VBGEN1:** VREG, BOR, HLVD, FRC, NVM and A/D Boost Band Gap Reference Enable bit⁽¹⁾

1 = Band gap reference is enabled

0 = Band gap reference is disabled

Note 1: When a module requests a band gap reference voltage, that reference will be enabled automatically after a brief start-up time. The user can manually enable the band gap references using the ANCFG register, before enabling the module requesting the band gap reference, to avoid this start-up time (~1 ms).

PIC24FJ256GA705 FAMILY

REGISTER 24-8: AD1CHITL: A/D SCAN COMPARE HIT REGISTER (LOW WORD)

U-0	U-0	R/W-0	R/W-0	R/W-0	R/W-0	R/W-0	R/W-0
—	—	CHH[13:8] ⁽¹⁾					
bit 15							bit 8

R/W-0	R/W-0	R/W-0	R/W-0	R/W-0	R/W-0	R/W-0	R/W-0
CHH[7:0]							
bit 7							bit 0

Legend:

R = Readable bit	W = Writable bit	U = Unimplemented bit, read as '0'
-n = Value at POR	'1' = Bit is set	'0' = Bit is cleared x = Bit is unknown

bit 15-14 **Unimplemented:** Read as '0'

bit 13-0 **CHH[13:0]:** A/D Compare Hit bits⁽¹⁾

If CM[1:0] = 11:

1 = A/D Result Buffer n has been written with data or a match has occurred

0 = A/D Result Buffer n has not been written with data

For All Other Values of CM[1:0]:

1 = A match has occurred on A/D Result Channel n

0 = No match has occurred on A/D Result Channel n

Note 1: The CHH[13:10] bits are not implemented on 28-pin devices.

PIC24FJ256GA705 FAMILY

REGISTER 24-9: AD1CSSH: A/D INPUT SCAN SELECT REGISTER (HIGH WORD)

U-0	U-0	U-0	R/W-0	R/W-0	R/W-0	R/W-0	R/W-0
—	—	—	CSS[28:24]				
bit 15						bit 8	

U-0	U-0	U-0	U-0	U-0	U-0	U-0	U-0
—	—	—	—	—	—	—	—
bit 7						bit 0	

Legend:

R = Readable bit W = Writable bit U = Unimplemented bit, read as '0'
-n = Value at POR '1' = Bit is set '0' = Bit is cleared x = Bit is unknown

- bit 15-13 **Unimplemented:** Read as '0'
- bit 12-8 **CSS[28:24]:** A/D Input Scan Selection bits
 - 1 = Includes corresponding channel for input scan
 - 0 = Skips channel for input scan
- bit 7-0 **Unimplemented:** Read as '0'

REGISTER 24-10: AD1CSSL: A/D INPUT SCAN SELECT REGISTER (LOW WORD)

R/W-0	R/W-0	R/W-0	R/W-0	R/W-0	R/W-0	R/W-0	R/W-0
CSS[15:8]							
bit 15						bit 8	

R/W-0	R/W-0	R/W-0	R/W-0	R/W-0	R/W-0	R/W-0	R/W-0
CSS[7:0]							
bit 7						bit 0	

Legend:

R = Readable bit W = Writable bit U = Unimplemented bit, read as '0'
-n = Value at POR '1' = Bit is set '0' = Bit is cleared x = Bit is unknown

- bit 15-0 **CSS[15:0]:** A/D Input Scan Selection bits
 - 1 = Includes corresponding channel for input scan
 - 0 = Skips channel for input scan

PIC24FJ256GA705 FAMILY

REGISTER 24-11: AD1CTMENH: A/D CTMU ENABLE REGISTER (HIGH WORD)

U-0	R/W-0	R/W-0	R/W-0	U-0	U-0	R/W-0	R/W-0
—	CTMEN[30:28]			—	—	CTMEN[25:24]	
bit 15						bit 8	
R/W-0	R/W-0	R/W-0	R/W-0	R/W-0	R/W-0	R/W-0	R/W-0
CTMEN[23:16] ⁽¹⁾							
bit 7						bit 0	

Legend:

R = Readable bit W = Writable bit U = Unimplemented bit, read as '0'
 -n = Value at POR '1' = Bit is set '0' = Bit is cleared x = Bit is unknown

- bit 15 **Unimplemented:** Read as '0'
- bit 14-12 **CTMEN[30:28]:** CTMU Enabled During Conversion bits
 1 = CTMU is enabled and connected to the selected channel during conversion
 0 = CTMU is not connected to this channel
- bit 11-10 **Unimplemented:** Read as '0'
- bit 9-0 **CTMEN[25:16]:** CTMU Enabled During Conversion bits⁽¹⁾
 1 = CTMU is enabled and connected to the selected channel during conversion
 0 = CTMU is not connected to this channel

Note 1: CTMEN[23:16] bits are not available on 64-pin parts.

REGISTER 24-12: AD1CTMENL: A/D CTMU ENABLE REGISTER (LOW WORD)

R/W-0	R/W-0	R/W-0	R/W-0	R/W-0	R/W-0	R/W-0	R/W-0
CTMEN[15:8]							
bit 15						bit 8	
R/W-0	R/W-0	R/W-0	R/W-0	R/W-0	R/W-0	R/W-0	R/W-0
CTMEN[7:0]							
bit 7						bit 0	

Legend:

R = Readable bit W = Writable bit U = Unimplemented bit, read as '0'
 -n = Value at POR '1' = Bit is set '0' = Bit is cleared x = Bit is unknown

- bit 15-0 **CTMEN[15:0]:** CTMU Enabled During Conversion bits
 1 = CTMU is enabled and connected to the selected channel during conversion
 0 = CTMU is not connected to this channel

FIGURE 24-3: 12-BIT A/D CONVERTER ANALOG INPUT MODEL

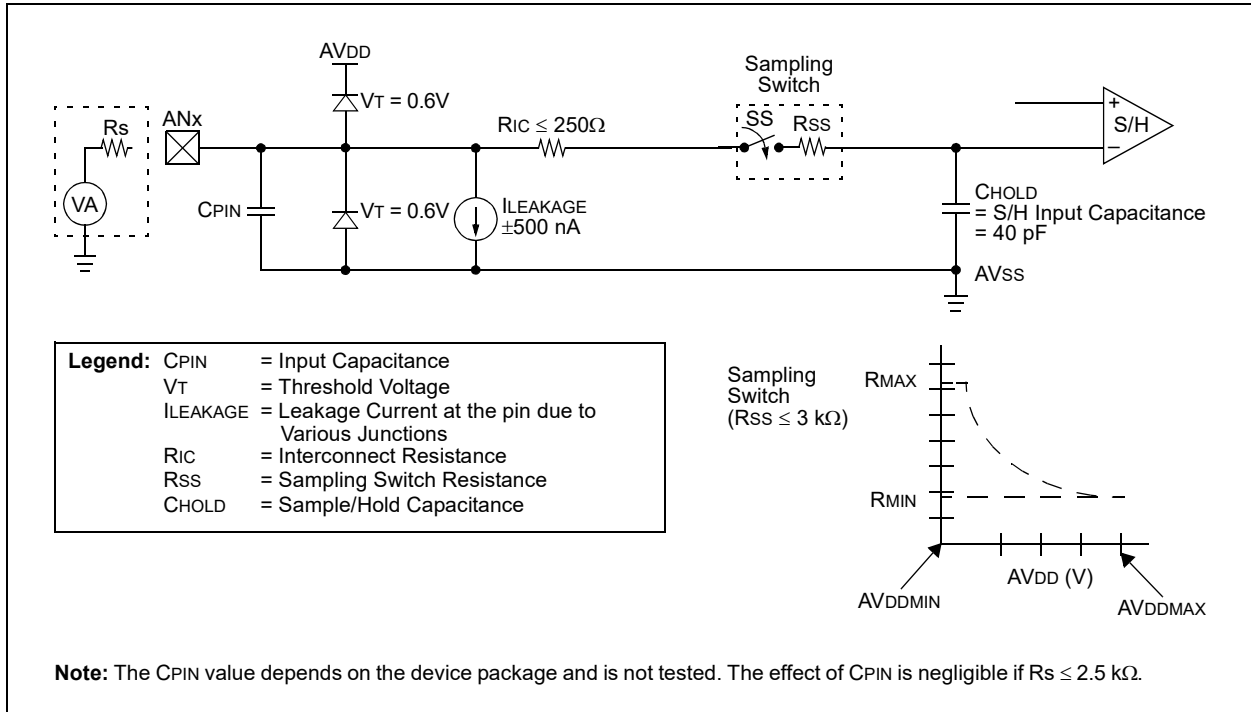

EQUATION 24-1: A/D CONVERSION CLOCK PERIOD

$$T_{AD} = T_{CY} (ADCS + 1)$$

$$ADCS = \frac{T_{AD}}{T_{CY}} - 1$$

Note: Based on $T_{CY} = 2/F_{OSC}$; Doze mode and PLL are disabled.

PIC24FJ256GA705 FAMILY

FIGURE 24-4: 12-BIT A/D TRANSFER FUNCTION

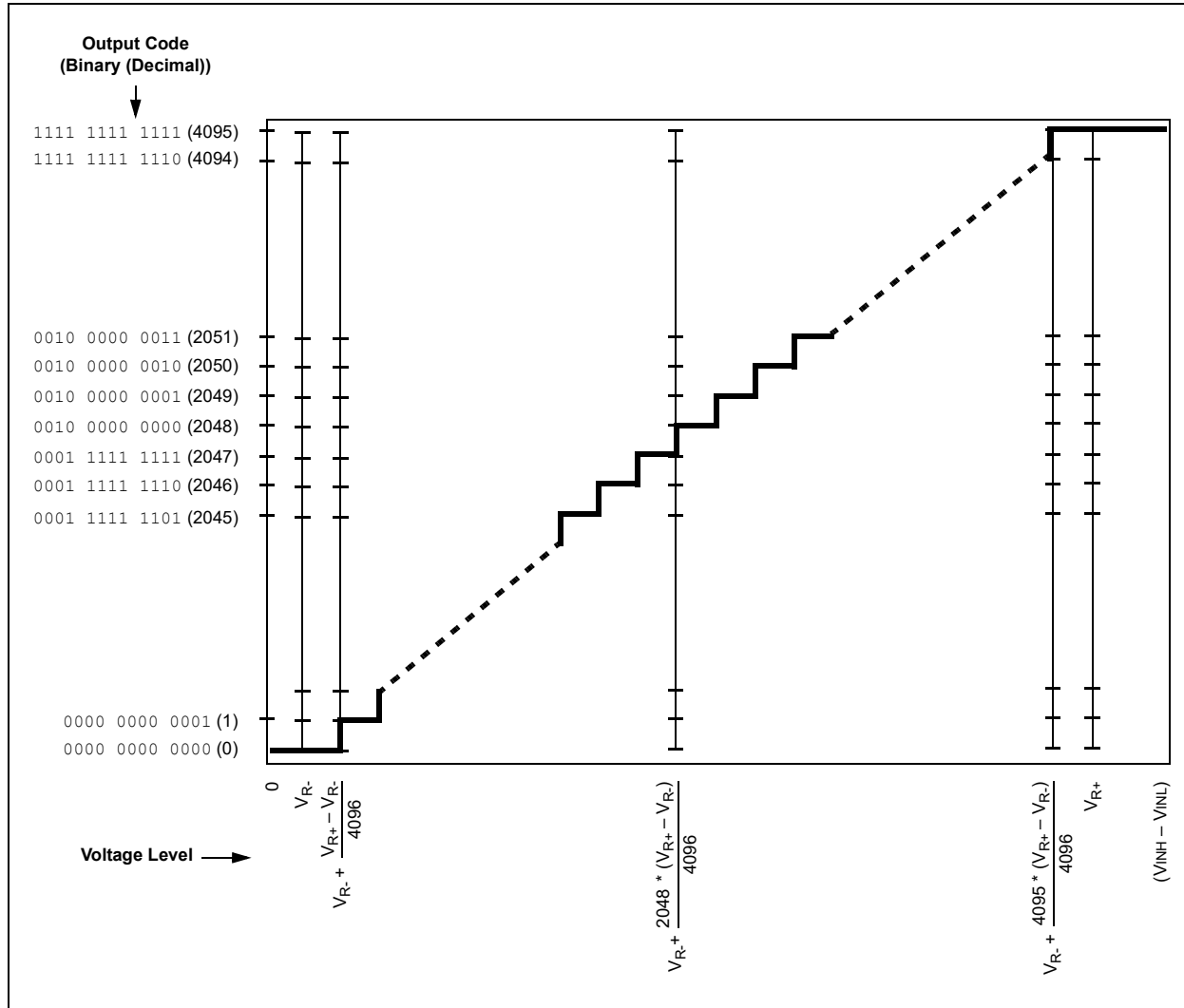
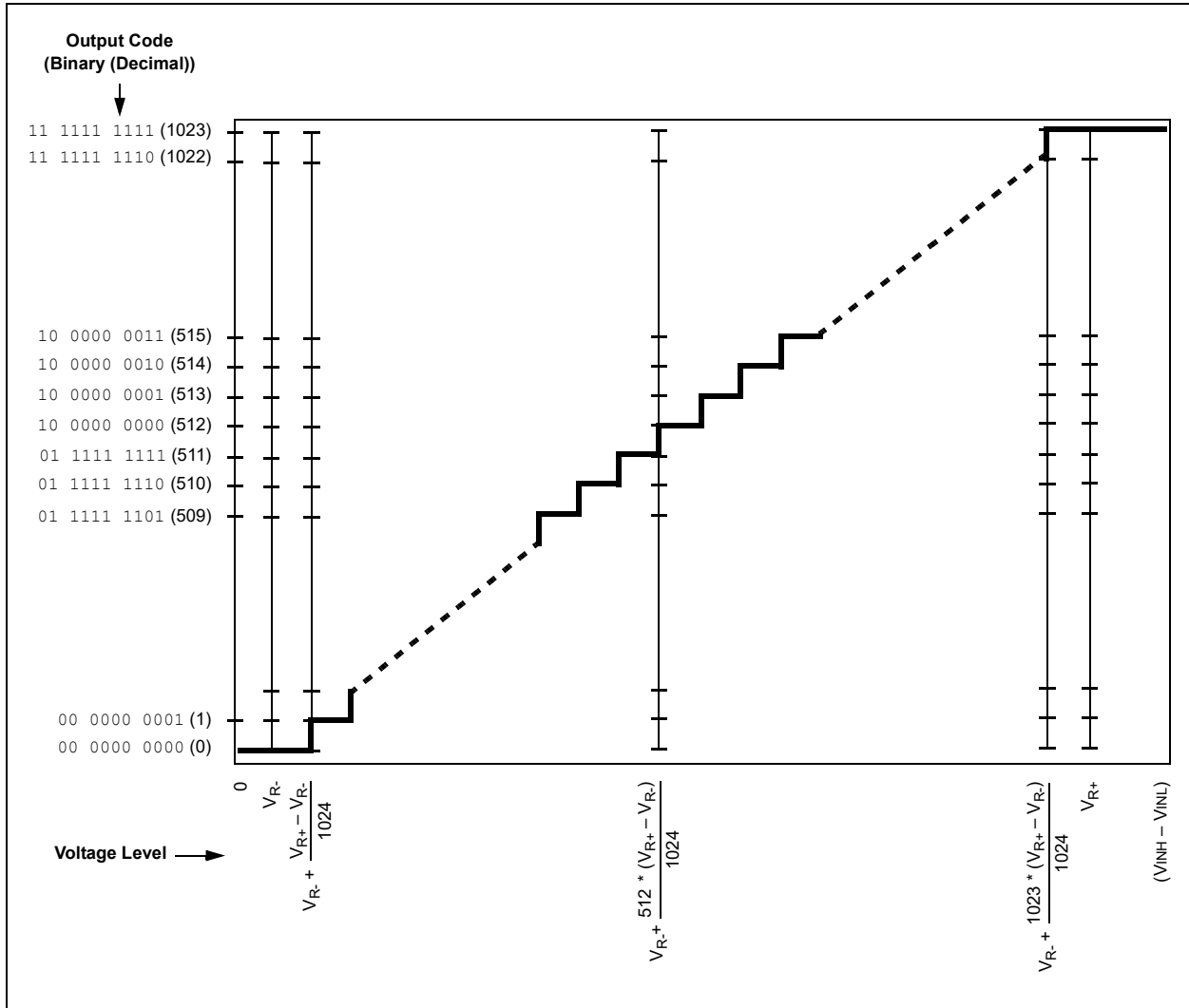

FIGURE 24-5: 10-BIT A/D TRANSFER FUNCTION



PIC24FJ256GA705 FAMILY

NOTES:

25.0 TRIPLE COMPARATOR MODULE

Note: This data sheet summarizes the features of this group of PIC24F devices. It is not intended to be a comprehensive reference source. For more information, refer to “**Scalable Comparator Module**” (www.microchip.com/DS39734) in the “*dsPIC33/PIC24 Family Reference Manual*”. The information in this data sheet supersedes the information in the FRM.

The triple comparator module provides three dual input comparators. The inputs to the comparator can be configured to use any one of five external analog inputs (CxINA, CxINB, CxINC, CxIND and CVREF+) and a

voltage reference input from one of the internal band gap references or the comparator voltage reference generator (VBG and CVREF).

The comparator outputs may be directly connected to the CxOUT pins. When the respective COE bit equals ‘1’, the I/O pad logic makes the unsynchronized output of the comparator available on the pin.

A simplified block diagram of the module is shown in [Figure 25-1](#). Diagrams of the possible individual comparator configurations are shown in [Figure 25-2](#) through [Figure 25-4](#).

Each comparator has its own control register, CMxCON ([Register 25-1](#)), for enabling and configuring its operation. The output and event status of all three comparators is provided in the CMSTAT register ([Register 25-2](#)).

FIGURE 25-1: TRIPLE COMPARATOR MODULE BLOCK DIAGRAM

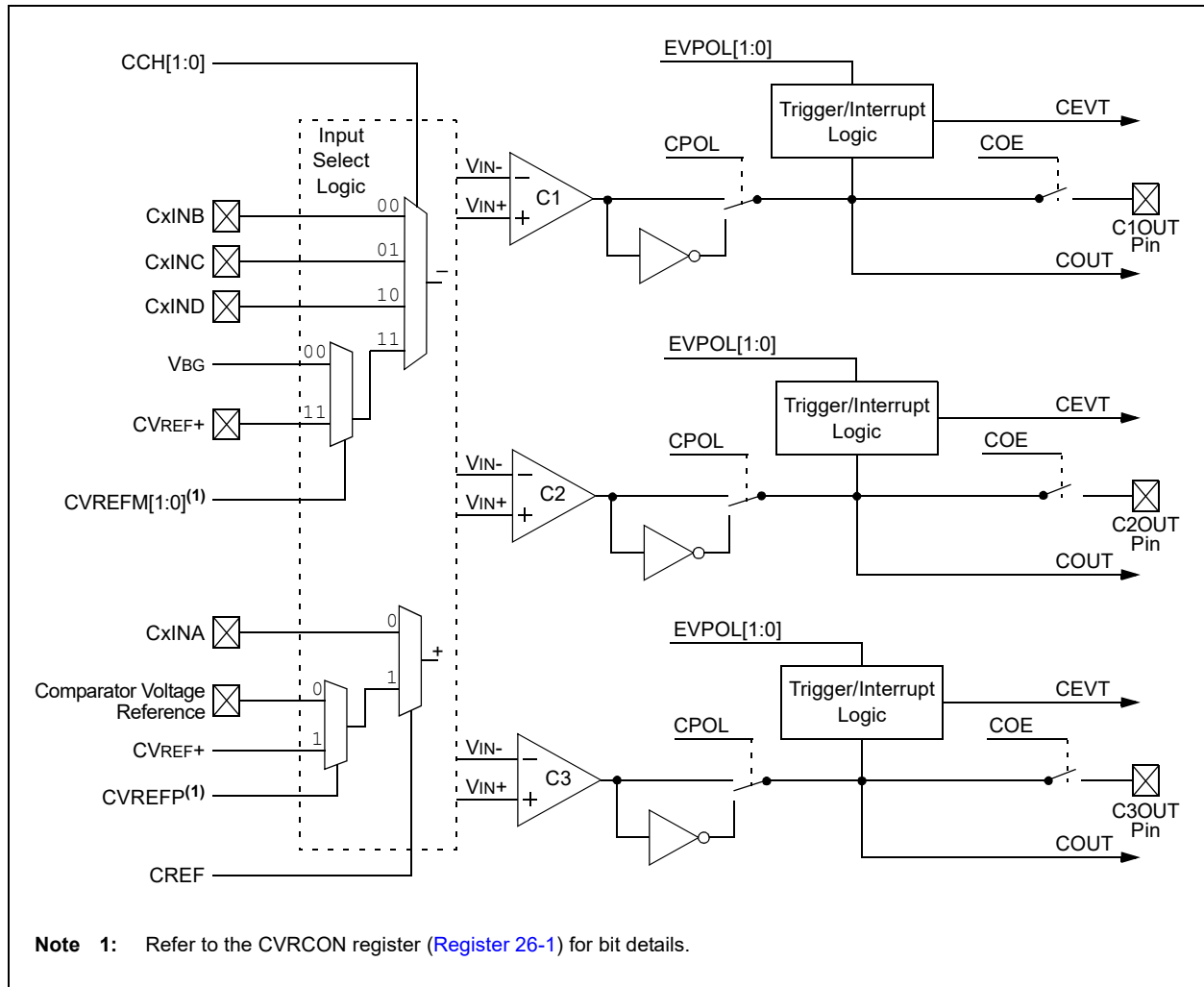

PIC24FJ256GA705 FAMILY

FIGURE 25-2: INDIVIDUAL COMPARATOR CONFIGURATIONS WHEN CREF = 0

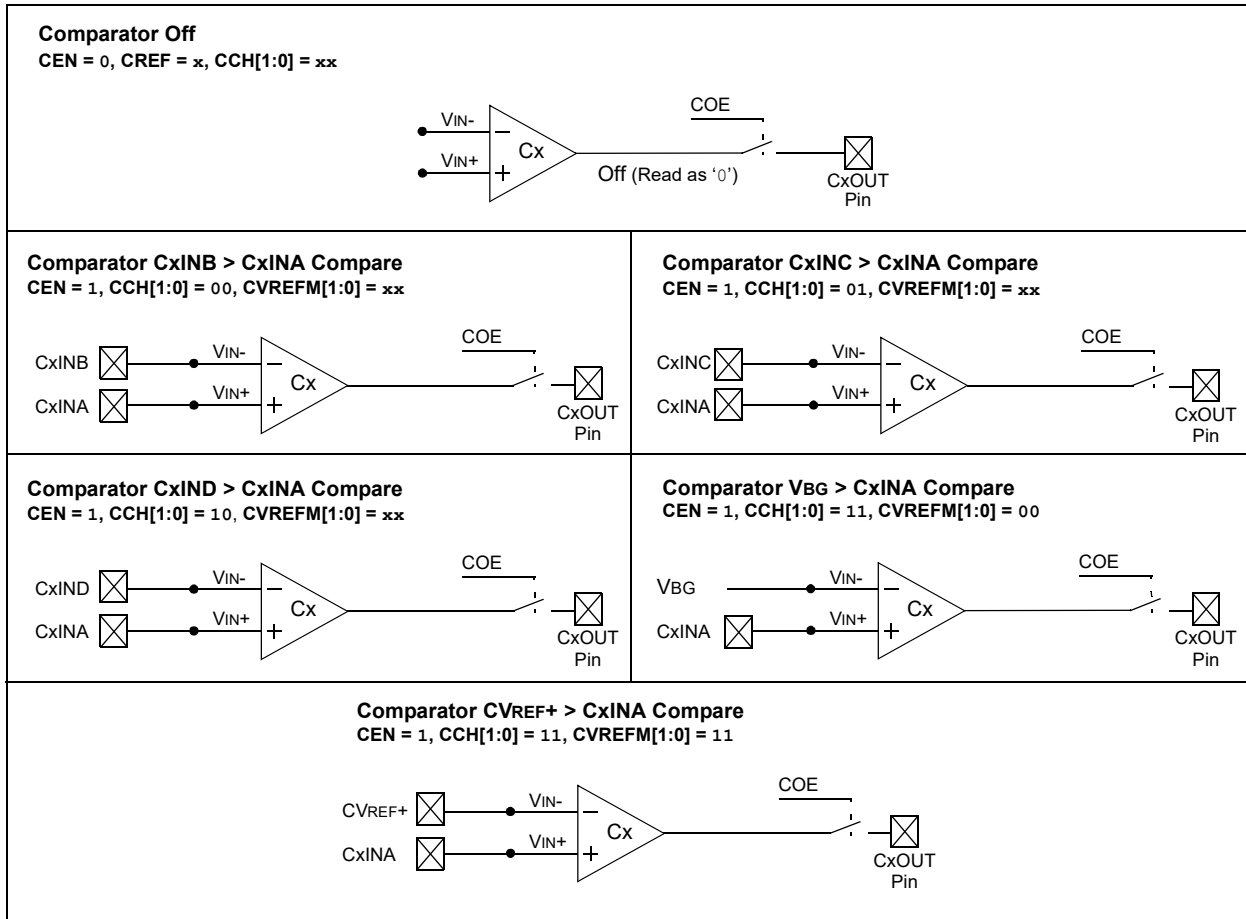

FIGURE 25-3: INDIVIDUAL COMPARATOR CONFIGURATIONS WHEN CREF = 1 AND CVREFP = 0

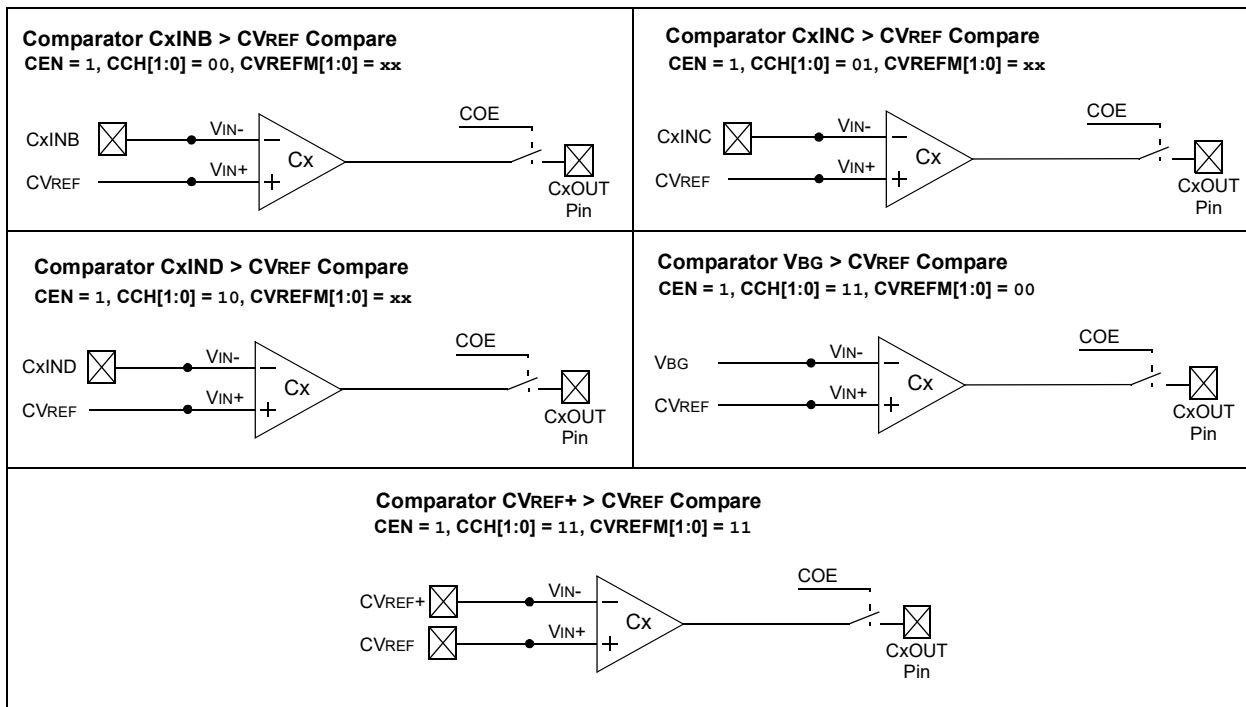
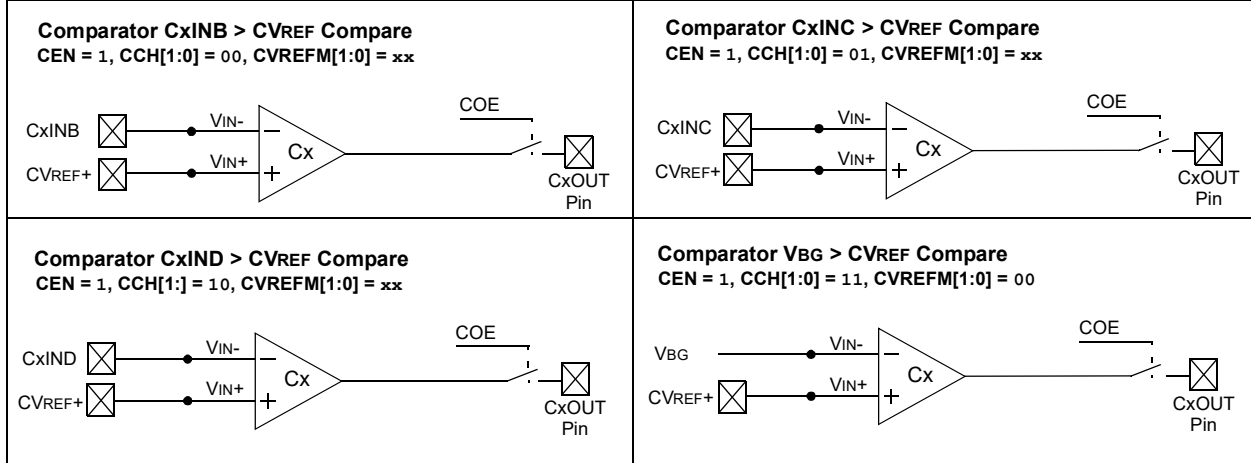

FIGURE 25-4: INDIVIDUAL COMPARATOR CONFIGURATIONS WHEN CREF = 1 AND CVREFP = 1



PIC24FJ256GA705 FAMILY

REGISTER 25-1: CMxCON: COMPARATOR x CONTROL REGISTERS (COMPARATORS 1 THROUGH 3)

R/W-0	R/W-0	R/W-0	U-0	U-0	U-0	HS/R/W-0	HSC/R-0
CEN	COE	CPOL	—	—	—	CEVT	COUT
bit 15						bit 8	

R/W-0	R/W-0	U-0	R/W-0	U-0	U-0	R/W-0	R/W-0
EVPOL1	EVPOL0	—	CREF	—	—	CCH1	CCH0
bit 7						bit 0	

Legend:	HS = Hardware Settable bit	HSC = Hardware Settable/Clearable bit
R = Readable bit	W = Writable bit	U = Unimplemented bit, read as '0'
-n = Value at POR	'1' = Bit is set	'0' = Bit is cleared x = Bit is unknown

- bit 15 **CEN:** Comparator Enable bit
 1 = Comparator is enabled
 0 = Comparator is disabled
- bit 14 **COE:** Comparator Output Enable bit
 1 = Comparator output is present on the CxOUT pin
 0 = Comparator output is internal only
- bit 13 **CPOL:** Comparator Output Polarity Select bit
 1 = Comparator output is inverted
 0 = Comparator output is not inverted
- bit 12-10 **Unimplemented:** Read as '0'
- bit 9 **CEVT:** Comparator Event bit
 1 = Comparator event that is defined by EVPOL[1:0] has occurred; subsequent triggers and interrupts are disabled until the bit is cleared
 0 = Comparator event has not occurred
- bit 8 **COUT:** Comparator Output bit
When CPOL = 0:
 1 = $V_{IN+} > V_{IN-}$
 0 = $V_{IN+} < V_{IN-}$
When CPOL = 1:
 1 = $V_{IN+} < V_{IN-}$
 0 = $V_{IN+} > V_{IN-}$
- bit 7-6 **EVPOL[1:0]:** Trigger/Event/Interrupt Polarity Select bits
 11 = Trigger/event/interrupt is generated on any change of the comparator output (while CEVT = 0)
 10 = Trigger/event/interrupt is generated on transition of the comparator output:
 If CPOL = 0 (noninverted polarity):
 High-to-low transition only.
 If CPOL = 1 (inverted polarity):
 Low-to-high transition only.
 01 = Trigger/event/interrupt is generated on transition of comparator output:
 If CPOL = 0 (noninverted polarity):
 Low-to-high transition only.
 If CPOL = 1 (inverted polarity):
 High-to-low transition only.
 00 = Trigger/event/interrupt generation is disabled
- bit 5 **Unimplemented:** Read as '0'

REGISTER 25-1: CMxCON: COMPARATOR x CONTROL REGISTERS (COMPARATORS 1 THROUGH 3) (CONTINUED)

- bit 4 **CREF:** Comparator Reference Select bits (noninverting input)
 1 = Noninverting input connects to the internal CVREF voltage
 0 = Noninverting input connects to the CxINA pin
- bit 3-2 **Unimplemented:** Read as '0'
- bit 1-0 **CCH[1:0]:** Comparator Channel Select bits
 11 = Inverting input of the comparator connects to the internal selectable reference voltage specified by the CVREFM[1:0] bits in the CVRCON register
 10 = Inverting input of the comparator connects to the CxIND pin
 01 = Inverting input of the comparator connects to the CxINC pin
 00 = Inverting input of the comparator connects to the CxINB pin

REGISTER 25-2: CMSTAT: COMPARATOR MODULE STATUS REGISTER

R/W-0	U-0	U-0	U-0	U-0	HSC/R-0	HSC/R-0	HSC/R-0
CMIDL	—	—	—	—	C3EVT	C2EVT	C1EVT
bit 15							bit 8

U-0	U-0	U-0	U-0	U-0	HSC/R-0	HSC/R-0	HSC/R-0
—	—	—	—	—	C3OUT	C2OUT	C1OUT
bit 7							bit 0

Legend:	HSC = Hardware Settable/Clearable bit		
R = Readable bit	W = Writable bit	U = Unimplemented bit, read as '0'	
-n = Value at POR	'1' = Bit is set	'0' = Bit is cleared	x = Bit is unknown

- bit 15 **CMIDL:** Comparator Stop in Idle Mode bit
 1 = Discontinues operation of all comparators when device enters Idle mode
 0 = Continues operation of all enabled comparators in Idle mode
- bit 14-11 **Unimplemented:** Read as '0'
- bit 10 **C3EVT:** Comparator 3 Event Status bit (read-only)
 Shows the current event status of Comparator 3 (CM3CON[9]).
- bit 9 **C2EVT:** Comparator 2 Event Status bit (read-only)
 Shows the current event status of Comparator 2 (CM2CON[9]).
- bit 8 **C1EVT:** Comparator 1 Event Status bit (read-only)
 Shows the current event status of Comparator 1 (CM1CON[9]).
- bit 7-3 **Unimplemented:** Read as '0'
- bit 2 **C3OUT:** Comparator 3 Output Status bit (read-only)
 Shows the current output of Comparator 3 (CM3CON[8]).
- bit 1 **C2OUT:** Comparator 2 Output Status bit (read-only)
 Shows the current output of Comparator 2 (CM2CON[8]).
- bit 0 **C1OUT:** Comparator 1 Output Status bit (read-only)
 Shows the current output of Comparator 1 (CM1CON[8]).

PIC24FJ256GA705 FAMILY

NOTES:

26.0 COMPARATOR VOLTAGE REFERENCE

Note: This data sheet summarizes the features of this group of PIC24F devices. It is not intended to be a comprehensive reference source. For more information, refer to “Dual Comparator Module” (www.microchip.com/DS39710) in the “dsPIC33/PIC24 Family Reference Manual”. The information in this data sheet supersedes the information in the FRM.

26.1 Configuring the Comparator Voltage Reference

The voltage reference module is controlled through the CVRCON register ([Register 26-1](#)). The comparator voltage reference provides two ranges of output voltage, each with 16 distinct levels. The primary difference between the ranges is the size of the steps selected by the CVREF Value Selection bits (CVR[4:0]), with one range offering finer resolution.

The comparator reference supply voltage can come from either VDD and VSS, or the external VREF+ and VREF-. The voltage source is selected by the CVRSS bit (CVRCON[5]).

The settling time of the comparator voltage reference must be considered when changing the CVREF output.

FIGURE 26-1: COMPARATOR VOLTAGE REFERENCE BLOCK DIAGRAM

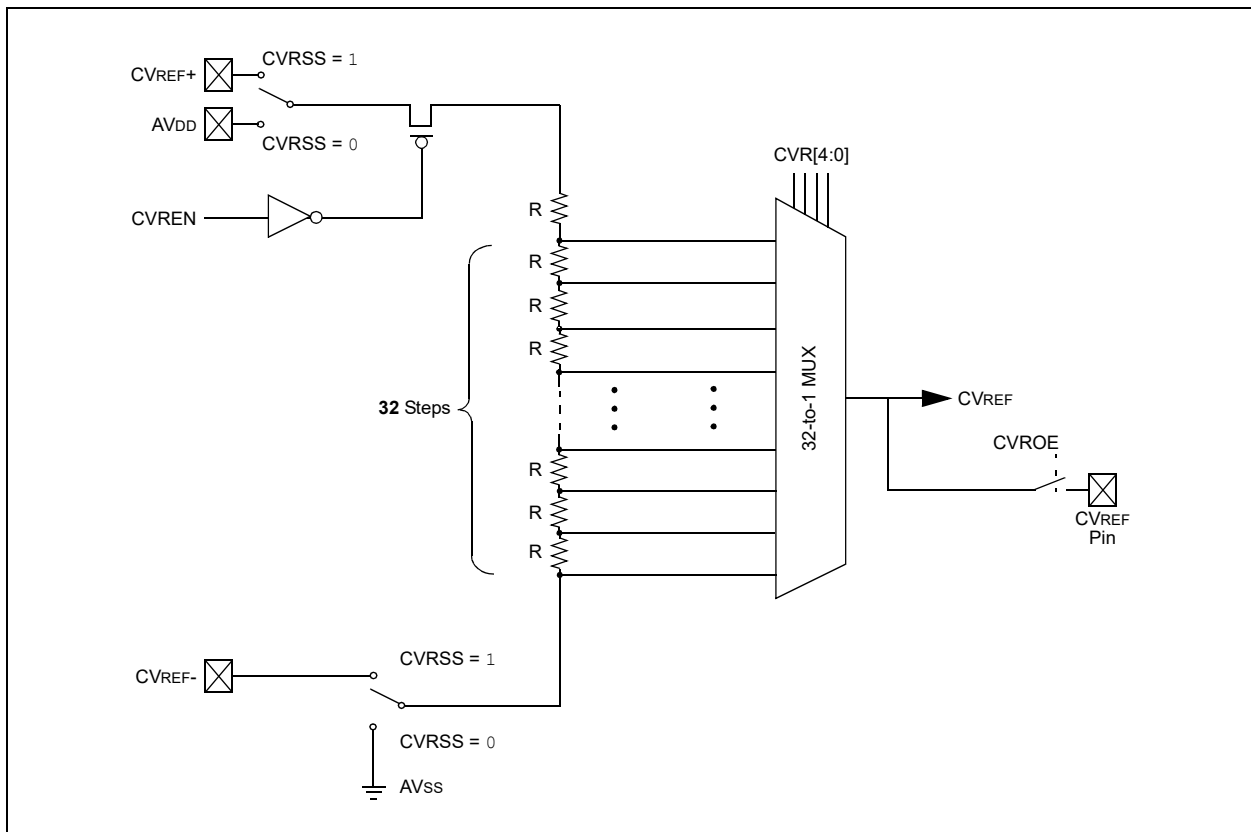

PIC24FJ256GA705 FAMILY

REGISTER 26-1: CVRCON: COMPARATOR VOLTAGE REFERENCE CONTROL REGISTER

U-0	U-0	U-0	U-0	U-0	R/W-0	R/W-0	R/W-0
—	—	—	—	—	CVREFP	CVREFM1	CVREFM0
bit 15						bit 8	

R/W-0	R/W-0	R/W-0	R/W-0	R/W-0	R/W-0	R/W-0	R/W-0
CVREN	CVROE	CVRSS	CVR4	CVR3	CVR2	CVR1	CVR0
bit 7						bit 0	

Legend:

R = Readable bit

W = Writable bit

U = Unimplemented bit, read as '0'

-n = Value at POR

'1' = Bit is set

'0' = Bit is cleared

x = Bit is unknown

- bit 15-11 **Unimplemented:** Read as '0'
- bit 10 **CVREFP:** Comparator Voltage Reference Select bit (valid only when CREF is '1')
- 1 = CVREF+ is used as a reference voltage to the comparators
- 0 = The CVR[4:0] bits (5-bit DAC) within this module provide the reference voltage to the comparators
- bit 9-8 **CVREFM[1:0]:** Comparator Band Gap Reference Source Select bits (valid only when CCH[1:0] = 11)
- 00 = Band gap voltage is provided as an input to the comparators
- 01 = Reserved
- 10 = Reserved
- 11 = CVREF+ is provided as an input to the comparators
- bit 7 **CVREN:** Comparator Voltage Reference Enable bit
- 1 = CVREF circuit is powered on
- 0 = CVREF circuit is powered down
- bit 6 **CVROE:** Comparator VREF Output Enable bit
- 1 = CVREF voltage level is output on the CVREF pin
- 0 = CVREF voltage level is disconnected from the CVREF pin
- bit 5 **CVRSS:** Comparator VREF Source Selection bit
- 1 = Comparator reference source, CVRSRC = CVREF+ – CVREF-
- 0 = Comparator reference source, CVRSRC = AVDD – AVSS
- bit 4-0 **CVR[4:0]:** Comparator VREF Value Selection bits ($0 \leq \text{CVR}[4:0] \leq 31$)
- When CVRSS = 1:
- $\text{CVREF} = (\text{CVREF-}) + (\text{CVR}[4:0]/32) \cdot (\text{CVREF+} - \text{CVREF-})$
- When CVRSS = 0:
- $\text{CVREF} = (\text{AVSS}) + (\text{CVR}[4:0]/32) \cdot (\text{AVDD} - \text{AVSS})$

27.0 CHARGE TIME MEASUREMENT UNIT (CTMU)

Note: This data sheet summarizes the features of this group of PIC24F devices. It is not intended to be a comprehensive reference source. For more information on the Charge Time Measurement Unit, refer to “**Charge Time Measurement Unit (CTMU) and CTMU Operation with Threshold Detect**” (www.microchip.com/DS30009743) in the “*dsPIC33/PIC24 Family Reference Manual*”. The information in this data sheet supersedes the information in the FRM.

The Charge Time Measurement Unit (CTMU) is a flexible analog module that provides charge measurement, accurate differential time measurement between pulse sources and asynchronous pulse generation. Its key features include:

- Thirteen External Edge Input Trigger Sources
- Polarity Control for Each Edge Source
- Control of Edge Sequence
- Control of Response to Edge Levels or Edge Transitions
- Time Measurement Resolution of One Nanosecond
- Accurate Current Source Suitable for Capacitive Measurement

Together with other on-chip analog modules, the CTMU can be used to precisely measure time, measure capacitance, measure relative changes in capacitance or generate output pulses that are independent of the system clock. The CTMU module is ideal for interfacing with capacitive-based touch sensors.

The CTMU is controlled through three registers: CTMUCON1L, CTMUCON1H and CTMUCON2L. CTMUCON1L enables the module, controls the mode of operation of the CTMU, controls edge sequencing, selects the current range of the current source and trims the current. CTMUCON1H controls edge source selection and edge source polarity selection. The CTMUCON2L register selects the current discharge source.

27.1 Measuring Capacitance

The CTMU module measures capacitance by generating an output pulse, with a width equal to the time between edge events, on two separate input channels. The pulse edge events to both input channels can be selected from four sources: two internal peripheral modules (OC1 and Timer1) and up to 13 external pins (CTED1 through CTED13). This pulse is used with the module's precision current source to calculate capacitance according to the relationship:

EQUATION 27-1:

$$I = C \cdot \frac{dV}{dT}$$

For capacitance measurements, the A/D Converter samples an external Capacitor (CAPP) on one of its input channels, after the CTMU output's pulse. A Precision Resistor (RPR) provides current source calibration on a second A/D channel. After the pulse ends, the converter determines the voltage on the capacitor. The actual calculation of capacitance is performed in software by the application.

Figure 27-1 illustrates the external connections used for capacitance measurements, and how the CTMU and A/D modules are related in this application. This example also shows the edge events coming from Timer1, but other configurations using external edge sources are possible. A detailed discussion on measuring capacitance and time with the CTMU module is provided in “**Charge Time Measurement Unit (CTMU) and CTMU Operation with Threshold Detect**” (www.microchip.com/DS30009743) in the “*dsPIC33/PIC24 Family Reference Manual*”.

PIC24FJ256GA705 FAMILY

FIGURE 27-1: TYPICAL CONNECTIONS AND INTERNAL CONFIGURATION FOR CAPACITANCE MEASUREMENT

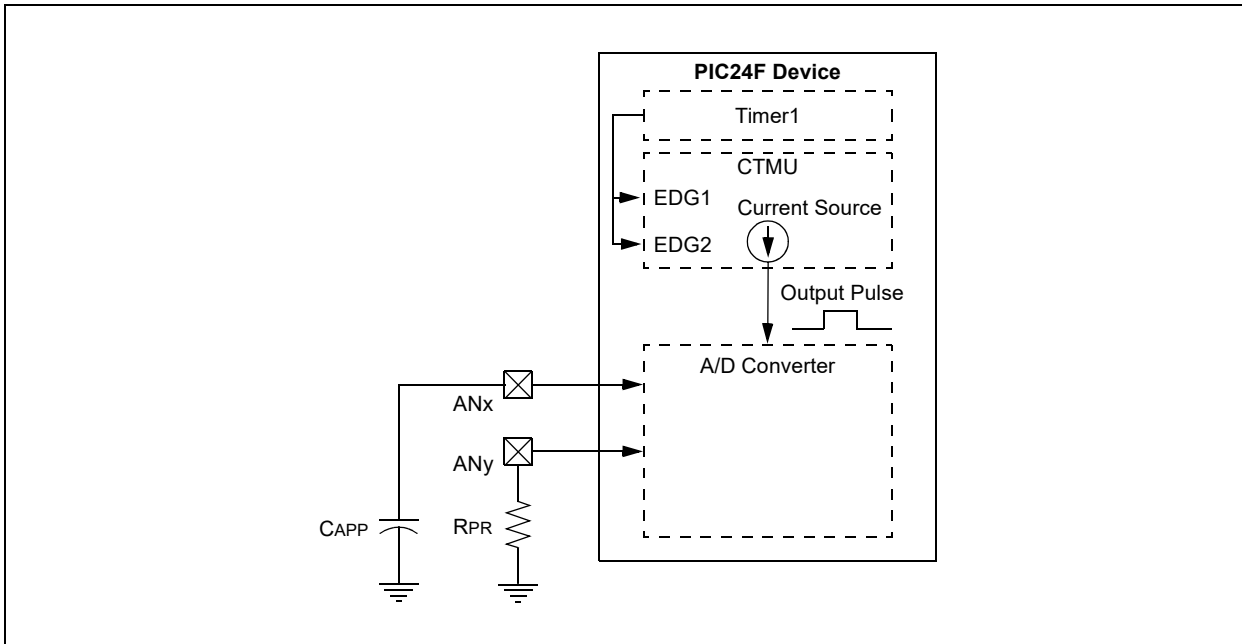

27.2 Measuring Time/Routing Current Source to A/D Input Pin

Time measurements on the pulse width can be similarly performed using the A/D module's Internal Capacitor (CAD) and a precision resistor for current calibration. [Figure 27-2](#) displays the external connections used for time measurements, and how the CTMU and A/D modules are related in this application. This example also shows both edge events coming from the external CTEDx pins, but other configurations using internal edge sources are possible.

This mode is enabled by clearing the TGEN bit (CTMUCON1L[12]). The current source is tied to the input of the A/D after the sampling switch. Therefore, the A/D bit, SAMP, must be set to '1' in order for the current to be routed through the channel selection MUX to the desired pin.

27.3 Pulse Generation and Delay

The CTMU module can also generate an output pulse with edges that are not synchronous with the device's system clock. More specifically, it can generate a pulse with a programmable delay from an edge event input to the module.

When the module is configured for pulse generation delay by setting the TGEN bit (CTMUCON1[12]), the internal current source is connected to the B input of Comparator 2. A capacitor (CDELAY) is connected to the Comparator 2 pin, C2INB, and the Comparator Voltage Reference, CVREF, is connected to C2INA. CVREF is then configured for a specific trip point. The module begins to charge CDELAY when an edge event is detected. When CDELAY charges above the CVREF trip point, a pulse is output on CTPLS. The length of the pulse delay is determined by the value of CDELAY and the CVREF trip point.

[Figure 27-3](#) illustrates the external connections for pulse generation, as well as the relationship of the different analog modules required. While CTED1 is shown as the input pulse source, other options are available. A detailed discussion on pulse generation with the CTMU module is provided in the *"dsPIC33/PIC24 Family Reference Manual"*.

FIGURE 27-2: TYPICAL CONNECTIONS AND INTERNAL CONFIGURATION FOR TIME MEASUREMENT (TGEN = 0)

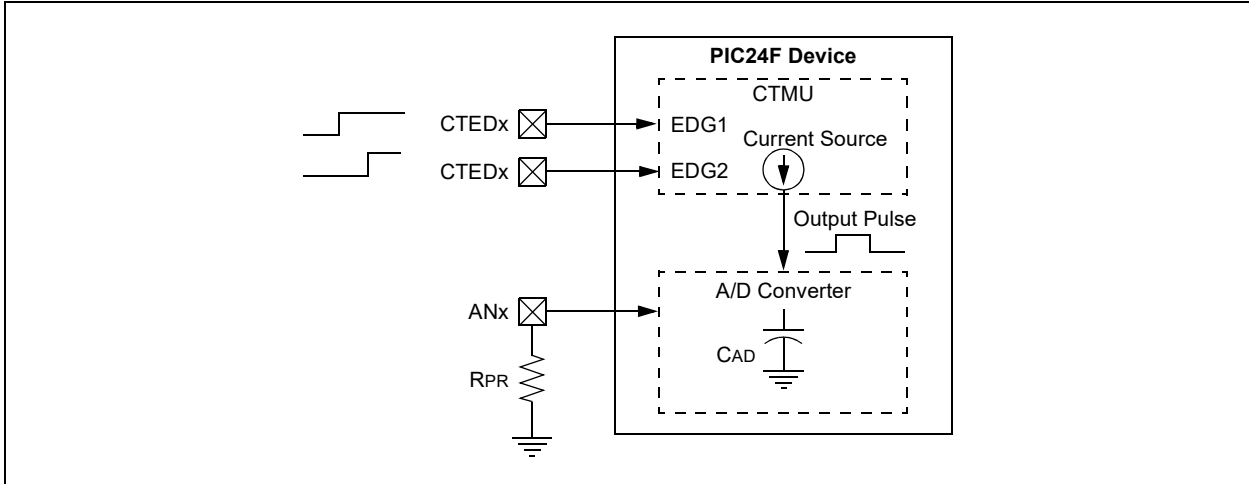
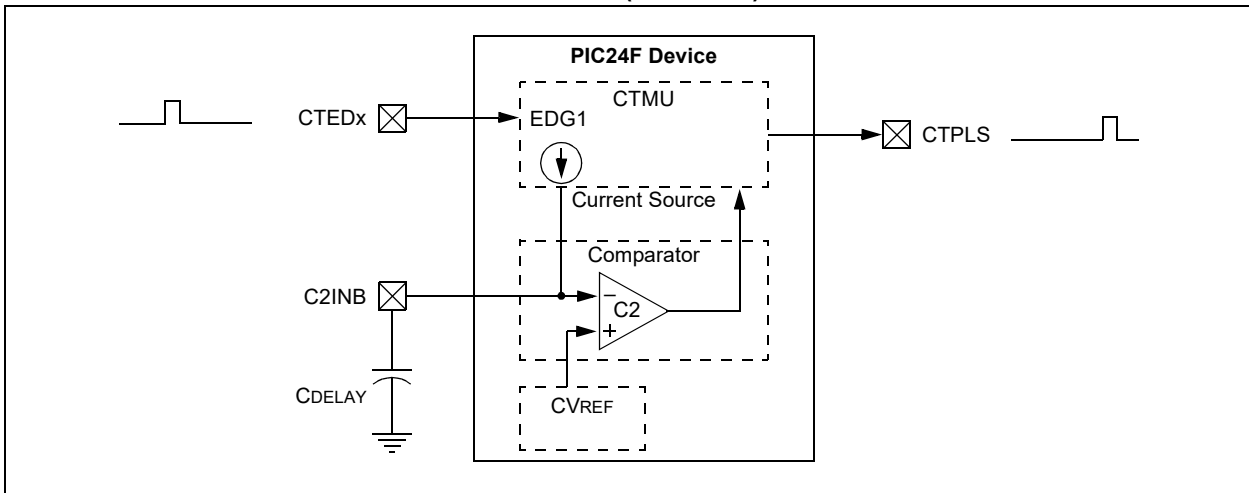

FIGURE 27-3: TYPICAL CONNECTIONS AND INTERNAL CONFIGURATION FOR PULSE DELAY GENERATION (TGEN = 1)



PIC24FJ256GA705 FAMILY

27.4 Measuring Die Temperature

The CTMU can be configured to use the A/D to measure the die temperature using dedicated A/D Channel 24. Perform the following steps to measure the diode voltage:

- The internal current source must be set for either 5.5 μA (IRNG[1:0] = 0x2) or 55 μA (IRNG[1:0] = 0x3).
- In order to route the current source to the diode, the EDG1STAT and EDG2STAT bits must be equal (either both '0' or both '1').
- The CTMREQ bit (AD1CON5[13]) must be set to '1'.
- The A/D Channel Select bits must be 24 (0x18) using a single-ended measurement.

The voltage of the diode will vary over temperature according to the graphs shown below (Figure 27-4). Note that the graphs are different, based on the magnitude of

the current source selected. The slopes are nearly linear over the range of -40°C to $+100^{\circ}\text{C}$ and the temperature can be calculated as follows:

EQUATION 27-2:

For 5.5 μA Current Source:

$$T_{die} = \frac{710 \text{ mV} - V_{diode}}{1.8}$$

where V_{diode} is in mV, T_{die} is in $^{\circ}\text{C}$

For 55 μA Current Source:

$$T_{die} = \frac{760 \text{ mV} - V_{diode}}{1.55}$$

where V_{diode} is in mV, T_{die} is in $^{\circ}\text{C}$

FIGURE 27-4: DIODE VOLTAGE (mV) vs. DIE TEMPERATURE (TYPICAL)

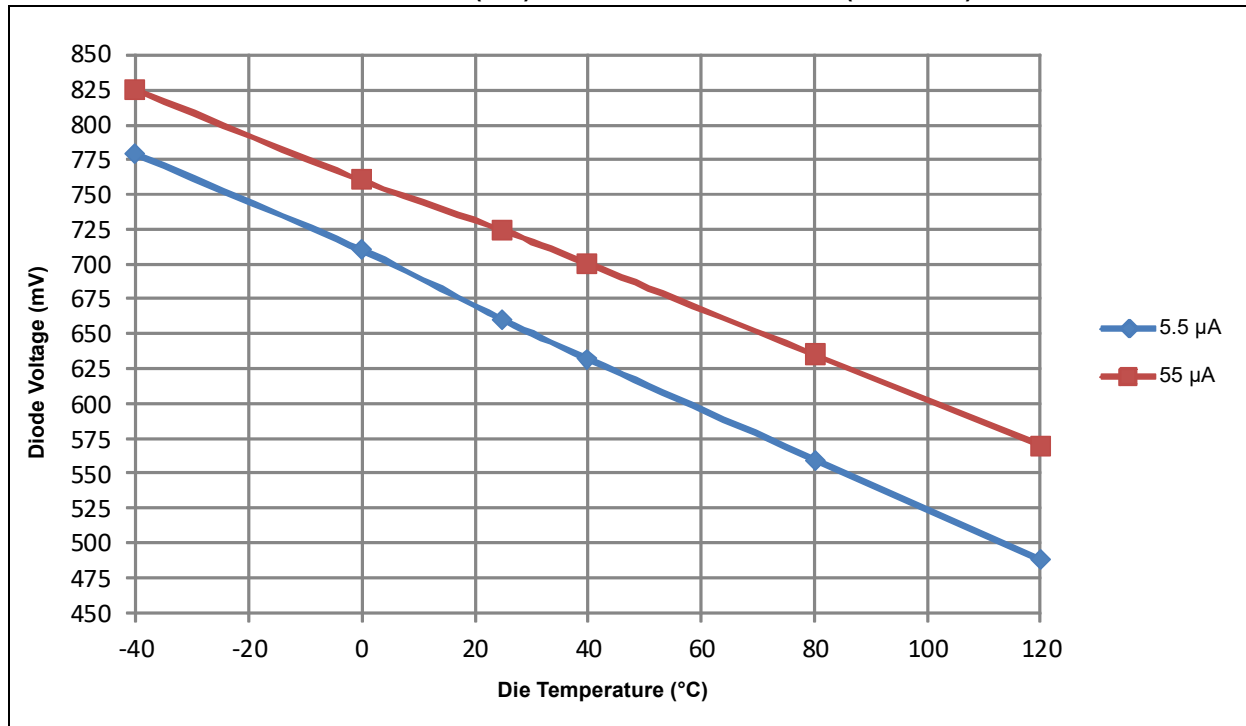

PIC24FJ256GA705 FAMILY

REGISTER 27-1: CTMUCON1L: CTMU CONTROL REGISTER 1 LOW

R/W-0	U-0	R/W-0	R/W-0	R/W-0	R/W-0	R/W-0	R/W-0
CTMUEN	—	CTMUSIDL	TGEN	EDGEN	EDGSEQEN	IDISSEN	CTTRIG
bit 15							bit 8

R/W-0	R/W-0	R/W-0	R/W-0	R/W-0	R/W-0	R/W-0	R/W-0
ITRIM5	ITRIM4	ITRIM3	ITRIM2	ITRIM1	ITRIM0	IRNG1	IRNG0
bit 7							bit 0

Legend:

R = Readable bit W = Writable bit U = Unimplemented bit, read as '0'
 -n = Value at POR '1' = Bit is set '0' = Bit is cleared x = Bit is unknown

- bit 15 **CTMUEN:** CTMU Enable bit
 1 = Module is enabled
 0 = Module is disabled
- bit 14 **Unimplemented:** Read as '0'
- bit 13 **CTMUSIDL:** CTMU Stop in Idle Mode bit
 1 = Discontinues module operation when device enters Idle mode
 0 = Continues module operation in Idle mode
- bit 12 **TGEN:** Time Generation Enable bit
 1 = Enables edge delay generation and routes the current source to the comparator pin
 0 = Disables edge delay generation and routes the current source to the selected A/D input pin
- bit 11 **EDGEN:** Edge Enable bit
 1 = Edges are not blocked
 0 = Edges are blocked
- bit 10 **EDGSEQEN:** Edge Sequence Enable bit
 1 = Edge 1 event must occur before Edge 2 event can occur
 0 = No edge sequence is needed
- bit 9 **IDISSEN:** Analog Current Source Control bit
 1 = Analog current source output is grounded
 0 = Analog current source output is not grounded
- bit 8 **CTTRIG:** CTMU Trigger Control bit
 1 = Trigger output is enabled
 0 = Trigger output is disabled
- bit 7-2 **ITRIM[5:0]:** Current Source Trim bits
 011111 = Maximum positive change from nominal current
 011110
 •
 •
 •
 000001 = Minimum positive change from nominal current
 000000 = Nominal current output specified by IRNG[1:0]
 111111 = Minimum negative change from nominal current
 •
 •
 •
 100010
 100001 = Maximum negative change from nominal current

PIC24FJ256GA705 FAMILY

REGISTER 27-1: CTMUCON1L: CTMU CONTROL REGISTER 1 LOW (CONTINUED)

bit 1-0 **IRNG[1:0]**: Current Source Range Select bits

If IRNGH = 0:

11 = 55 μ A range

10 = 5.5 μ A range

01 = 550 nA range

00 = 550 μ A range

If IRNGH = 1:

11 = Reserved

10 = Reserved

01 = 2.2 mA range

00 = 550 μ A range

PIC24FJ256GA705 FAMILY

REGISTER 27-2: CTMUCON1H: CTMU CONTROL REGISTER 1 HIGH

R/W-0	R/W-0	R/W-0	R/W-0	R/W-0	R/W-0	R/W-0	R/W-0
EDG1MOD	EDG1POL	EDG1SEL3	EDG1SEL2	EDG1SEL1	EDG1SEL0	EDG2STAT	EDG1STAT
bit 15						bit 8	

R/W-0	R/W-0	R/W-0	R/W-0	R/W-0	R/W-0	U-0	R/W-0
EDG2MOD	EDG2POL	EDG2SEL3	EDG2SEL2	EDG2SEL1	EDG2SEL0	—	IRNGH
bit 7						bit 0	

Legend:

R = Readable bit

W = Writable bit

U = Unimplemented bit, read as '0'

-n = Value at POR

'1' = Bit is set

'0' = Bit is cleared

x = Bit is unknown

bit 15 **EDG1MOD:** Edge 1 Edge-Sensitive Select bit

1 = Input is edge-sensitive

0 = Input is level-sensitive

bit 14 **EDG1POL:** Edge 1 Polarity Select bit

1 = Edge 1 is programmed for a positive edge response

0 = Edge 1 is programmed for a negative edge response

bit 13-10 **EDG1SEL[3:0]:** Edge 1 Source Select bits

1111 = CMP C3OUT

1110 = CMP C2OUT

1101 = CMP C1OUT

1100 = IC3 interrupt

1011 = IC2 interrupt

1010 = IC1 interrupt

1001 = CTED8 pin

1000 = CTED7 pin

0111 = CTED6 pin

0110 = CTED5 pin

0101 = CTED4 pin

0100 = CTED3 pin

0011 = CTED1 pin

0010 = CTED2 pin

0001 = OC1

0000 = Timer1 match

bit 9 **EDG2STAT:** Edge 2 Status bit

Indicates the status of Edge 2 and can be written to control current source.

1 = Edge 2 has occurred

0 = Edge 2 has not occurred

bit 8 **EDG1STAT:** Edge 1 Status bit

Indicates the status of Edge 1 and can be written to control current source.

1 = Edge 1 has occurred

0 = Edge 1 has not occurred

bit 7 **EDG2MOD:** Edge 2 Edge-Sensitive Select bit

1 = Input is edge-sensitive

0 = Input is level-sensitive

bit 6 **EDG2POL:** Edge 2 Polarity Select bit

1 = Edge 2 is programmed for a positive edge response

0 = Edge 2 is programmed for a negative edge response

PIC24FJ256GA705 FAMILY

REGISTER 27-2: CTMUCON1H: CTMU CONTROL REGISTER 1 HIGH (CONTINUED)

bit 5-2 **EDG2SEL[3:0]:** Edge 2 Source Select bits

1111 = CMP C3OUT
1110 = CMP C2OUT
1101 = CMP C1OUT
1100 = Peripheral clock
1011 = IC3 interrupt
1010 = IC2 interrupt
1001 = IC1 interrupt
1000 = CTED13 pin
0111 = CTED12 pin
0110 = CTED11 pin
0101 = CTED10 pin
0100 = CTED9 pin
0011 = CTED1 pin
0010 = CTED2 pin
0001 = OC1
0000 = Timer1 match

bit 1 **Unimplemented:** Read as '0'

bit 0 **IRNGH:** High-Current Range Select bit

1 = Uses the higher current ranges (550 μ A-2.2 mA)
0 = Uses the lower current ranges (550 nA-50 μ A)
Current output is set by the IRNG[1:0] bits in the CTMUCON1L register.

PIC24FJ256GA705 FAMILY

REGISTER 27-3: CTMUCON2L: CTMU CONTROL REGISTER 2 LOW

U-0	U-0	U-0	U-0	U-0	U-0	U-0	U-0
—	—	—	—	—	—	—	—
bit 15						bit 8	

U-0	U-0	U-0	R/W-0	U-0	R/W-0	R/W-0	R/W-0
—	—	—	IRSTEN	—	DSCHS2	DSCHS1	DSCHS0
bit 7						bit 0	

Legend:

R = Readable bit W = Writable bit U = Unimplemented bit, read as '0'
 -n = Value at POR '1' = Bit is set '0' = Bit is cleared x = Bit is unknown

bit 15-5 **Unimplemented:** Read as '0'

bit 4 **IRSTEN:** CTMU Current Source Reset Enable bit
 1 = Signal selected by DSCHS[2:0] bits or IDISSEN control bit will reset CTMU edge detect logic
 0 = CTMU edge detect logic must be reset by software

bit 3 **Unimplemented:** Read as '0'

bit 2-0 **DSCHS[2:0]:** Discharge Source Select Bits
 111 = CLC2 out
 110 = CLC1 out
 101 = Disabled
 100 = A/D end of conversion
 011 = MCCP3 auxiliary output
 010 = MCCP2 auxiliary output
 001 = MCCP1 auxiliary output
 000 = Disabled

PIC24FJ256GA705 FAMILY

NOTES:

28.0 HIGH/LOW-VOLTAGE DETECT (HLVD)

Note: This data sheet summarizes the features of this group of PIC24F devices. It is not intended to be a comprehensive reference source. For more information on the High/Low-Voltage Detect, refer to “**High-Level Integration with Programmable High/Low-Voltage Detect (HLVD)**” (www.microchip.com/DS39725) in the “*dsPIC33/PIC24 Family Reference Manual*”. The information in this data sheet supersedes the information in the FRM.

An interrupt flag is set if the device experiences an excursion past the trip point in the direction of change. If the interrupt is enabled, the program execution will branch to the interrupt vector address and the software can then respond to the interrupt. The LVDIF flag may be set during a POR or BOR event. The firmware should clear the flag before the application uses it for the first time, even if the interrupt was disabled.

The HLVD Control register (see [Register 28-1](#)) completely controls the operation of the HLVD module. This allows the circuitry to be “turned off” by the user under software control, which minimizes the current consumption for the device.

The High/Low-Voltage Detect (HLVD) module is a programmable circuit that allows the user to specify both the device voltage trip point and the direction of change.

FIGURE 28-1: HIGH/LOW-VOLTAGE DETECT (HLVD) MODULE BLOCK DIAGRAM

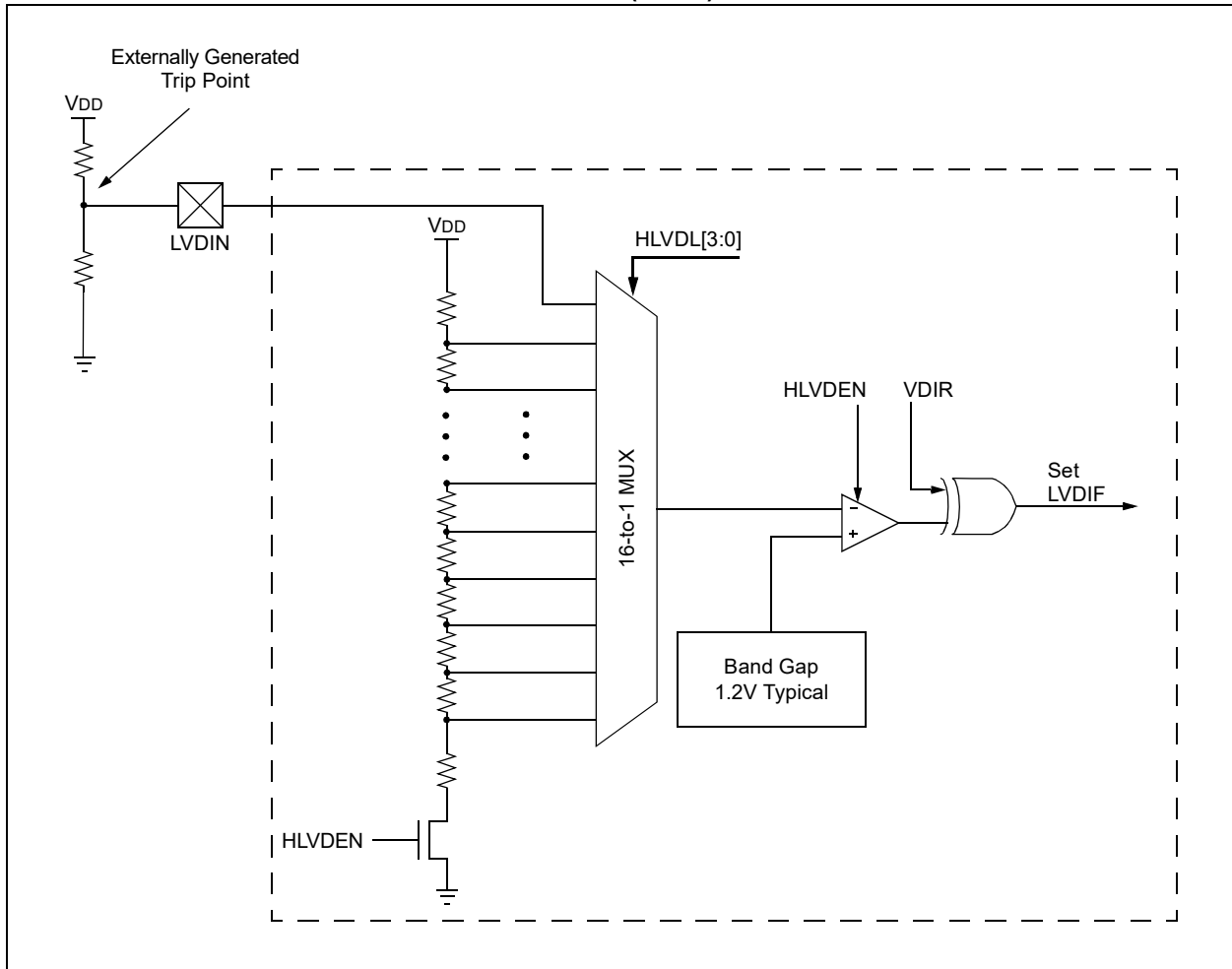

PIC24FJ256GA705 FAMILY

REGISTER 28-1: HLVDCON: HIGH/LOW-VOLTAGE DETECT CONTROL REGISTER

R/W-0	U-0	R/W-0	U-0	R/W-0	HS/HC/R-0	HS/HC/R-0	HS/HC/R-0
HLVDEN	—	LSIDL	—	VDIR	BGVST	IRVST	LVDEVT ⁽²⁾
bit 15				bit 8			

U-0	U-0	U-0	U-0	R/W-0	R/W-0	R/W-0	R/W-0
—	—	—	—	HLVDL[3:0]			
bit 7				bit 0			

Legend:	HS = Hardware Settable bit	HC = Hardware Clearable bit
R = Readable bit	W = Writable bit	U = Unimplemented bit, read as '0'
-n = Value at POR	'1' = Bit is set	'0' = Bit is cleared x = Bit is unknown

- bit 15 **HLVDEN:** High/Low-Voltage Detect Power Enable bit
 1 = HLVD is enabled
 0 = HLVD is disabled
- bit 14 **Unimplemented:** Read as '0'
- bit 13 **LSIDL:** HLVD Stop in Idle Mode bit
 1 = Discontinues module operation when device enters Idle mode
 0 = Continues module operation in Idle mode
- bit 12 **Unimplemented:** Read as '0'
- bit 11 **VDIR:** Voltage Change Direction Select bit
 1 = Event occurs when voltage equals or exceeds trip point (HLVDL[3:0])
 0 = Event occurs when voltage equals or falls below trip point (HLVDL[3:0])
- bit 10 **BGVST:** Band Gap Voltage Stable Flag bit
 1 = Indicates that the band gap voltage is stable
 0 = Indicates that the band gap voltage is unstable
- bit 9 **IRVST:** Internal Reference Voltage Stable Flag bit
 1 = Internal reference voltage is stable; the High-Voltage Detect logic generates the interrupt flag at the specified voltage range
 0 = Internal reference voltage is unstable; the High-Voltage Detect logic will not generate the interrupt flag at the specified voltage range and the HLVD interrupt should not be enabled
- bit 8 **LVDEVT:** Low-Voltage Event Status bit⁽²⁾
 1 = LVD event is true during current instruction cycle
 0 = LVD event is not true during current instruction cycle
- bit 7-4 **Unimplemented:** Read as '0'
- bit 3-0 **HLVDL[3:0]:** High/Low-Voltage Detection Limit bits
 1111 = External analog input is used (input comes from the LVDIN pin)
 1110 = Trip Point 1⁽¹⁾
 1101 = Trip Point 2⁽¹⁾
 1100 = Trip Point 3⁽¹⁾
 •
 •
 •
 0100 = Trip Point 11⁽¹⁾
 00xx = Unused

- Note 1:** For the actual trip point, see [Section 32.0 “Electrical Characteristics”](#).
- Note 2:** The LVDIF flag cannot be cleared by software unless LVDEVT = 0. The voltage must be monitored so that the HLVD condition (as set by VDIR and HLVDL[3:0]) is not asserted.

29.0 SPECIAL FEATURES

Note: This data sheet summarizes the features of this group of PIC24F devices. It is not intended to be a comprehensive reference source. For more information, refer to the following sections of the “*dsPIC33/PIC24 Family Reference Manual*”, which are available from the Microchip website (www.microchip.com). The information in this data sheet supersedes the information in the FRM.

- “**Watchdog Timer (WDT)**”
(www.microchip.com/DS39697)
- “**High-Level Device Integration**”
(www.microchip.com/DS39719)
- “**Programming and Diagnostics**”
(www.microchip.com/DS39716)

PIC24FJ256GA705 family devices include several features intended to maximize application flexibility and reliability, and minimize cost through elimination of external components. These are:

- Flexible Configuration
- Watchdog Timer (WDT)
- Code Protection
- JTAG Boundary Scan Interface
- In-Circuit Serial Programming™
- In-Circuit Emulation

29.1 Configuration Bits

The Configuration bits are stored in the last page location of implemented program memory. These bits can be set or cleared to select various device configurations. There are two types of Configuration bits: system operation bits and code-protect bits. The system operation bits determine the power-on settings for system-level components, such as the oscillator and the Watchdog Timer. The code-protect bits prevent program memory from being read and written.

29.1.1 CONSIDERATIONS FOR CONFIGURING PIC24FJ256GA705 FAMILY DEVICES

In PIC24FJ256GA705 family devices, the Configuration bytes are implemented as volatile memory. This means that configuration data must be programmed each time the device is powered up. Configuration data are stored in the three words at the top of the on-chip program memory space, known as the Flash Configuration Words. Their specific locations are shown in [Table 29-1](#). The configuration data are automatically loaded from the Flash Configuration Words to the proper Configuration registers during device Resets.

Note: Configuration data are reloaded on all types of device Resets.

When creating applications for these devices, users should always specifically allocate the location of the Flash Configuration Word for configuration data. This is to make certain that program code is not stored in this address when the code is compiled.

The upper byte of all Flash Configuration Words in program memory should always be ‘0000 0000’. This makes them appear to be NOP instructions in the remote event that their locations are ever executed by accident. Since Configuration bits are not implemented in the corresponding locations, writing ‘0’s to these locations has no effect on device operation.

TABLE 29-1: CONFIGURATION WORD ADDRESSES

Configuration Register	PIC24FJ256GA70X	PIC24FJ128GA70X	PIC24FJ64GA70X
FSEC	02AF00h	015F00h	00AF00h
FBSLIM	02AF10h	015F10h	00AF10h
FSIGN	02AF14h	015F14h	00AF14h
FOSCSEL	02AF18h	015F18h	00AF18h
FOSC	02AF1Ch	015F1Ch	00AF1Ch
FWDT	02AF20h	015F20h	00AF20h
FPOR	02AF24h	015F24h	00AF24h
FICD	02AF28h	015F28h	00AF28h
FDEVOPT1	02AF2Ch	015F2Ch	00AF2Ch

PIC24FJ256GA705 FAMILY

REGISTER 29-1: FSEC CONFIGURATION REGISTER

U-1	U-1	U-1	U-1	U-1	U-1	U-1	U-1
—	—	—	—	—	—	—	—
bit 23						bit 16	

R/PO-1	U-1	U-1	U-1	R/PO-1	R/PO-1	R/PO-1	R/PO-1
AIVTDIS	—	—	—	CSS2	CSS1	CSS0	CWRP
bit 15						bit 8	

R/PO-1	R/PO-1	R/PO-1	U-1	R/PO-1	R/PO-1	R/PO-1	R/PO-1
GSS1	GSS0	GWRP	—	BSEN	BSS1	BSS0	BWRP
bit 7						bit 0	

Legend:	PO = Program Once bit		
R = Readable bit	W = Writable bit	U = Unimplemented bit, read as '0'	
-n = Value at POR	'1' = Bit is set	'0' = Bit is cleared	x = Bit is unknown

- bit 23-16 **Unimplemented:** Read as '1'
- bit 15 **AIVTDIS:** Alternate Interrupt Vector Table Disable bit
 - 1 = Disables AIVT; INTCON2[8] (AIVTEN) bit is not available
 - 0 = Enables AIVT; INTCON2[8] (AIVTEN) bit is available
- bit 14-12 **Unimplemented:** Read as '1'
- bit 11-9 **CSS[2:0]:** Configuration Segment (CS) Code Protection Level bits
 - 111 = No protection (other than CWRP)
 - 110 = Standard security
 - 10x = Enhanced security
 - 0xx = High security
- bit 8 **CWRP:** Configuration Segment Program Write Protection bit
 - 1 = Configuration Segment is not write-protected
 - 0 = Configuration Segment is write-protected
- bit 7-6 **GSS[1:0]:** General Segment (GS) Code Protection Level bits
 - 11 = No protection (other than GWRP)
 - 10 = Standard security
 - 0x = High security
- bit 5 **GWRP:** General Segment Program Write Protection bit
 - 1 = General Segment is not write-protected
 - 0 = General Segment is write-protected
- bit 4 **Unimplemented:** Read as '1'
- bit 3 **BSEN:** Boot Segment (BS) Control bit
 - 1 = No Boot Segment is enabled
 - 0 = Boot Segment size is determined by BSLIM[12:0]
- bit 2-1 **BSS[1:0]:** Boot Segment Code Protection Level bits
 - 11 = No protection (other than BWRP)
 - 10 = Standard security
 - 0x = High security
- bit 0 **BWRP:** Boot Segment Program Write Protection bit
 - 1 = Boot Segment can be written
 - 0 = Boot Segment is write-protected

PIC24FJ256GA705 FAMILY

REGISTER 29-2: FBSLIM CONFIGURATION REGISTER

U-1	U-1	U-1	U-1	U-1	U-1	U-1	U-1
—	—	—	—	—	—	—	—
bit 23							bit 16

U-1	U-1	U-1	R/PO-1	R/PO-1	R/PO-1	R/PO-1	R/PO-1
—	—	—	BSLIM[12:8]				
bit 15							bit 8

R/PO-1	R/PO-1	R/PO-1	R/PO-1	R/PO-1	R/PO-1	R/PO-1	R/PO-1
BSLIM[7:0]							
bit 7							bit 0

Legend:	PO = Program Once bit
R = Readable bit	W = Writable bit
-n = Value at POR	'1' = Bit is set
	'0' = Bit is cleared
	x = Bit is unknown

bit 23-13 **Unimplemented:** Read as '1'

bit 12-0 **BSLIM[12:0]:** Active Boot Segment Code Flash Page Address Limit (Inverted) bits

This bit field contains the last active Boot Segment Page + 1 (i.e., first page address of GS). The value is stored as an inverted page address, such that programming additional '0's can only increase the size of BS. If BSLIM[12:0] is set to all '1's (unprogrammed default), the active Boot Segment size is zero.

PIC24FJ256GA705 FAMILY

REGISTER 29-3: FSIGN CONFIGURATION REGISTER

U-1	U-1	U-1	U-1	U-1	U-1	U-1	U-1
—	—	—	—	—	—	—	—
bit 23						bit 16	

r-0	U-1	U-1	U-1	U-1	U-1	U-1	U-1
—	—	—	—	—	—	—	—
bit 15						bit 8	

U-1	U-1	U-1	U-1	U-1	U-1	U-1	U-1
—	—	—	—	—	—	—	—
bit 7						bit 0	

Legend:	PO = Program Once bit	r = Reserved bit
R = Readable bit	W = Writable bit	U = Unimplemented bit, read as '0'
-n = Value at POR	'1' = Bit is set	'0' = Bit is cleared
		x = Bit is unknown

bit 23-16 **Unimplemented:** Read as '1'

bit 15 **Reserved:** Maintain as '0'

bit 14-0 **Unimplemented:** Read as '1'

PIC24FJ256GA705 FAMILY

REGISTER 29-4: FOSCSSEL CONFIGURATION REGISTER

U-1	U-1	U-1	U-1	U-1	U-1	U-1	U-1
—	—	—	—	—	—	—	—
bit 23						bit 16	

U-1	U-1	U-1	U-1	U-1	U-1	r-0	r-0
—	—	—	—	—	—	—	—
bit 15						bit 8	

R/PO-1	R/PO-1	R/PO-1	R/PO-1	R/PO-1	R/PO-1	R/PO-1	R/PO-1
IESO	PLLMODE3	PLLMODE2	PLLMODE1	PLLMODE0	FNOSC2	FNOSC1	FNOSC0
bit 7						bit 0	

Legend:	PO = Program Once bit	r = Reserved bit
R = Readable bit	W = Writable bit	U = Unimplemented bit, read as '0'
-n = Value at POR	'1' = Bit is set	'0' = Bit is cleared
		x = Bit is unknown

bit 23-10 **Unimplemented:** Read as '1'

bit 9-8 **Reserved:** Maintain as '0'

bit 7 **IESO:** Two-Speed Oscillator Start-up Enable bit

1 = Starts up the device with FRC, then automatically switches to the user-selected oscillator when ready

0 = Starts up the device with the user-selected oscillator source

bit 6-3 **PLLMODE[3:0]:** Frequency Multiplier Select bits

1111 = No PLL is used (PLLEN bit is unavailable)

1110 = 8x PLL is selected

1101 = 6x PLL is selected

1100 = 4x PLL is selected

0111 = 96 MHz PLL is selected (Input Frequency = 48 MHz)

0110 = 96 MHz PLL is selected (Input Frequency = 32 MHz)

0101 = 96 MHz PLL is selected (Input Frequency = 24 MHz)

0100 = 96 MHz PLL is selected (Input Frequency = 20 MHz)

0011 = 96 MHz PLL is selected (Input Frequency = 16 MHz)

0010 = 96 MHz PLL is selected (Input Frequency = 12 MHz)

0001 = 96 MHz PLL is selected (Input Frequency = 8 MHz)

0000 = 96 MHz PLL is selected (Input Frequency = 4 MHz)

bit 2-0 **FNOSC[2:0]:** Oscillator Selection bits

111 = Oscillator with Frequency Divider (OSCFDIV)

110 = Reserved

101 = Low-Power RC Oscillator (LPRC)

100 = Secondary Oscillator (SOSC)

011 = Primary Oscillator with PLL (XTPLL, HSPLL, ECPLL)

010 = Primary Oscillator (XT, HS, EC)

001 = Fast RC Oscillator with PLL (FRCPLL)

000 = Fast RC Oscillator (FRC)

PIC24FJ256GA705 FAMILY

REGISTER 29-5: FOSC CONFIGURATION REGISTER

U-1	U-1	U-1	U-1	U-1	U-1	U-1	U-1
—	—	—	—	—	—	—	—
bit 23						bit 16	

U-1	U-1	U-1	U-1	U-1	U-1	U-1	U-1
—	—	—	—	—	—	—	—
bit 15						bit 8	

R/PO-1	R/PO-1	R/PO-1	R/PO-1	R/PO-1	R/PO-1	R/PO-1	R/PO-1
FCKSM1	FCKSM0	IOL1WAY	PLLSS	SOSCSEL	OSCIOFCN	POSCMD1	POSCMD0
bit 7						bit 0	

Legend:	PO = Program Once bit
R = Readable bit	W = Writable bit
-n = Value at POR	'1' = Bit is set
	U = Unimplemented bit, read as '0'
	'0' = Bit is cleared
	x = Bit is unknown

bit 23-8 **Unimplemented:** Read as '1'

bit 7-6 **FCKSM[1:0]:** Clock Switching and Monitor Selection bits

- 1x = Clock switching and the Fail-Safe Clock Monitor are disabled
- 01 = Clock switching is enabled, Fail-Safe Clock Monitor is disabled
- 00 = Clock switching and the Fail-Safe Clock Monitor are enabled

bit 5 **IOL1WAY:** Peripheral Pin Select Configuration bit

- 1 = The IOLOCK bit can be set only once (with unlock sequence).
- 0 = The IOLOCK bit can be set and cleared as needed (with unlock sequence)

bit 4 **PLLSS:** PLL Secondary Selection Configuration bit

- This Configuration bit only takes effect when the PLL is NOT being used by the system (i.e., not selected as part of the system clock source). Used to generate an independent clock out of REFO.
- 1 = PLL is fed by the Primary Oscillator
- 0 = PLL is fed by the on-chip Fast RC (FRC) Oscillator

bit 3 **SOSCSEL:** SOSC Selection Configuration bit

- 1 = Crystal (SOSCI/SOSCO) mode
- 0 = Digital (SOSCI) Externally Supplied Clock mode

bit 2 **OSCIOFCN:** CLKO Enable Configuration bit

- 1 = CLKO output signal is active on the OSCO pin (when the Primary Oscillator is disabled or configured for EC mode)
- 0 = CLKO output is disabled

bit 1-0 **POSCMD[1:0]:** Primary Oscillator Configuration bits

- 11 = Primary Oscillator mode is disabled
- 10 = HS Oscillator mode is selected (10 MHz-32 MHz)
- 01 = XT Oscillator mode is selected (1.5 MHz-10 MHz)
- 00 = External Clock mode is selected

REGISTER 29-6: FWDT CONFIGURATION REGISTER

U-1	U-1	U-1	U-1	U-1	U-1	U-1	U-1
—	—	—	—	—	—	—	—
bit 23						bit 16	

U-1	R/PO-1	R/PO-1	U-1	R/PO-1	U-1	R/PO-1	R/PO-1
—	WDTCLK1	WDTCLK0	—	WDTCMX	—	WDTWIN1	WDTWIN0
bit 15						bit 8	

R/PO-1	R/PO-1	R/PO-1	R/PO-1	R/PO-1	R/PO-1	R/PO-1	R/PO-1
WINDIS	FWDTEN1	FWDTEN0	FWPSA	WDTPS3	WDTPS2	WDTPS1	WDTPS0
bit 7						bit 0	

Legend:	PO = Program Once bit
R = Readable bit	W = Writable bit
-n = Value at POR	'1' = Bit is set
	'0' = Bit is cleared
	x = Bit is unknown
	U = Unimplemented bit, read as '0'

bit 23-15 **Unimplemented:** Read as '1'

bit 14-13 **WDTCLK[1:0]:** Watchdog Timer Clock Select bits (when WDTCMX = 1)

11 = Always uses LPRC

10 = Uses FRC when WINDIS = 0, system clock is not LPRC and device is not in Sleep; otherwise, uses LPRC

01 = Always uses SOSC

00 = Uses peripheral clock when system clock is not LPRC and device is not in Sleep; otherwise, uses LPRC

bit 12 **Unimplemented:** Read as '1'

bit 11 **WDTCMX:** WDT Clock MUX Control bit

1 = Enables WDT clock MUX, WDT clock is selected by WDTCLK[1:0]

0 = WDT clock is LPRC

bit 10 **Unimplemented:** Read as '1'

bit 9-8 **WDTWIN[1:0]:** Watchdog Timer Window Width bits

11 = WDT window is 25% of the WDT period

10 = WDT window is 37.5% of the WDT period

01 = WDT window is 50% of the WDT period

00 = WDT window is 75% of the WDT period

bit 7 **WINDIS:** Windowed Watchdog Timer Disable bit

1 = Windowed WDT is disabled

0 = Windowed WDT is enabled

bit 6-5 **FWDTEN[1:0]:** Watchdog Timer Enable bits

11 = WDT is enabled

10 = WDT is disabled (control is placed on the SWDTEN bit)

01 = WDT is enabled only while device is active and disabled in Sleep; SWDTEN bit is disabled

00 = WDT and SWDTEN are disabled

bit 4 **FWPSA:** Watchdog Timer Prescaler bit

1 = WDT prescaler ratio of 1:128

0 = WDT prescaler ratio of 1:32

PIC24FJ256GA705 FAMILY

REGISTER 29-6: FWDT CONFIGURATION REGISTER (CONTINUED)

bit 3-0 **WDTPS[3:0]**: Watchdog Timer Postscale Select bits

1111 = 1:32,768

1110 = 1:16,384

1101 = 1:8,192

1100 = 1:4,096

1011 = 1:2,048

1010 = 1:1,024

1001 = 1:512

1000 = 1:256

0111 = 1:128

0110 = 1:64

0101 = 1:32

0100 = 1:16

0011 = 1:8

0010 = 1:4

0001 = 1:2

0000 = 1:1

PIC24FJ256GA705 FAMILY

REGISTER 29-7: FPOR CONFIGURATION REGISTER

U-1	U-1	U-1	U-1	U-1	U-1	U-1	U-1
—	—	—	—	—	—	—	—
bit 23						bit 16	

U-1	U-1	U-1	U-1	U-1	U-1	U-1	U-1
—	—	—	—	—	—	—	—
bit 15						bit 8	

U-1	U-1	U-1	U-1	R/PO-1	R/PO-1	R/PO-1	R/PO-1
—	—	—	—	DNVPEN	$\overline{\text{LPCFG}}$	BOREN1	BOREN0
bit 7						bit 0	

Legend:	PO = Program Once bit
R = Readable bit	W = Writable bit
-n = Value at POR	'1' = Bit is set
	'0' = Bit is cleared
	x = Bit is unknown
	U = Unimplemented bit, read as '0'

bit 23-4 **Unimplemented:** Read as '1'

bit 3 **DNVPEN:** Downside Voltage Protection Enable bit
 1 = Downside protection is enabled when BOR is inactive
 0 = Downside protection is disabled when BOR is inactive

bit 2 **LPCFG:** Low-Power Regulator Control bit
 1 = Retention feature is not available
 0 = Retention feature is available and controlled by RETEN during Sleep

bit 1-0 **BOREN[1:0]:** Brown-out Reset Enable bits
 11 = Brown-out Reset is enabled in hardware; SBOREN bit is disabled
 10 = Brown-out Reset is enabled only while device is active and is disabled in Sleep; SBOREN bit is disabled
 01 = Brown-out Reset is controlled with the SBOREN bit setting
 00 = Brown-out Reset is disabled in hardware; SBOREN bit is disabled

PIC24FJ256GA705 FAMILY

REGISTER 29-8: FICD CONFIGURATION REGISTER

U-1	U-1	U-1	U-1	U-1	U-1	U-1	U-1
—	—	—	—	—	—	—	—
bit 23						bit 16	

U-1	U-1	U-1	U-1	U-1	U-1	U-1	U-1
—	—	—	—	—	—	—	—
bit 15						bit 8	

r-1	U-1	R/PO-1	U-1	U-1	U-1	R/PO-1	R/PO-1
—	—	JTAGEN	—	—	—	ICS1	ICS0
bit 7						bit 0	

Legend:	PO = Program Once bit	r = Reserved bit
R = Readable bit	W = Writable bit	U = Unimplemented bit, read as '0'
-n = Value at POR	'1' = Bit is set	'0' = Bit is cleared
		x = Bit is unknown

- bit 23-8 **Unimplemented:** Read as '1'
- bit 7 **Reserved:** Maintain as '1'
- bit 6 **Unimplemented:** Read as '1'
- bit 5 **JTAGEN:** JTAG Port Enable bit
 - 1 = JTAG port is enabled
 - 0 = JTAG port is disabled
- bit 4-2 **Unimplemented:** Read as '1'
- bit 1-0 **ICS[1:0]:** ICD Communication Channel Select bits
 - 11 = Communicates on PGC1/PGD1
 - 10 = Communicates on PGC2/PGD2
 - 01 = Communicates on PGC3/PGD3
 - 00 = Reserved; do not use

PIC24FJ256GA705 FAMILY

REGISTER 29-9: FDEVOPT1 CONFIGURATION REGISTER

U-1	U-1	U-1	U-1	U-1	U-1	U-1	U-1
—	—	—	—	—	—	—	—
bit 23							bit 16

U-1	U-1	U-1	U-1	U-1	U-1	U-1	U-1
—	—	—	—	—	—	—	—
bit 15							bit 8

U-1	U-1	U-1	R/PO-1	R/PO-1	R/PO-1	R/PO-1	U-1
—	—	—	ALTI2C1	SOSCHP	TMPRPIN	ALTCMPI	—
bit 7							bit 0

Legend:	PO = Program Once bit
R = Readable bit	W = Writable bit
-n = Value at POR	'1' = Bit is set
	U = Unimplemented bit, read as '0'
	'0' = Bit is cleared
	x = Bit is unknown

bit 23-5 **Unimplemented:** Read as '1'

bit 4 **ALTI2C1:** Alternate I2C1 bit
 1 = SDA1 and SCL1 on RB9 and RB8
 0 = ASDA1 and ASCL1 on RB5 and RB6

bit 3 **SOSCHP:** SOSC High-Power Enable bit (valid only when SOSCSEL = 1)
 1 = SOSC High-Power mode is enabled
 0 = SOSC Low-Power mode is enabled (see [Section 9.7.3 “Low-Power SOSC Operation”](#) for more information)

bit 2 **TMPRPIN:** Tamper Pin Enable bit
 1 = $\overline{\text{TMPRN}}$ pin function is disabled (RB9)
 0 = $\overline{\text{TMPRN}}$ pin function is enabled

bit 1 **ALTCMPI:** Alternate Comparator Input Enable bit
 1 = C1INC, C2INC and C3INC are on their standard pin locations
 0 = C1INC, C2INC and C3INC are on RB9⁽¹⁾

bit 0 **Unimplemented:** Read as '1'

Note 1: RB9 is used for multiple functions, but only one use case is allowable.

PIC24FJ256GA705 FAMILY

TABLE 29-2: PIC24FJ CORE DEVICE ID REGISTERS

Address	Name	Bit															
		15	14	13	12	11	10	9	8	7	6	5	4	3	2	1	0
FF0000h	DEVID	FAMID[7:0]								DEV[7:0]							
FF0002h	DEVREV	—											REV[3:0]				

TABLE 29-3: DEVICE ID BIT FIELD DESCRIPTIONS

Bit Field	Register	Description
FAMID[7:0]	DEVID	Encodes the family ID of the device; FAMID = 0x75.
DEV[7:0]	DEVID	Encodes the individual ID of the device.
REV[3:0]	DEVREV	Encodes the sequential (numerical) revision identifier of the device.

TABLE 29-4: PIC24FJ256GA705 FAMILY DEVICE IDs

Device	DEVID
PIC24FJ64GA705	07
PIC24FJ128GA705	0B
PIC24FJ256GA705	0F
PIC24FJ64GA704	05
PIC24FJ128GA704	09
PIC24FJ256GA704	0D
PIC24FJ64GA702	06
PIC24FJ128GA702	0A
PIC24FJ256GA702	0E

29.2 Unique Device Identifier (UDID)

All PIC24FJ256GA705 family devices are individually encoded during final manufacturing with a Unique Device Identifier, or UDID. The UDID cannot be erased by a bulk erase command or any other user-accessible means. This feature allows for manufacturing traceability of Microchip Technology devices in applications where this is a requirement. It may also be used by the application manufacturer for any number of things that may require unique identification, such as:

- Tracking the device
- Unique serial number
- Unique security key

The UDID comprises five 24-bit program words. When taken together, these fields form a unique 120-bit identifier.

The UDID is stored in five read-only locations, located between 0x801600 and 0x801608 in the device configuration space. [Table 29-5](#) lists the addresses of the identifier words and shows their contents.

TABLE 29-5: UDID ADDRESSES

UDID	Address	Description
UDID1	0x801600	UDID Word 1
UDID2	0x801602	UDID Word 2
UDID3	0x801604	UDID Word 3
UDID4	0x801606	UDID Word 4
UDID5	0x801608	UDID Word 5

29.3 On-Chip Voltage Regulator

All PIC24FJ256GA705 family devices power their core digital logic at a nominal 1.8V. This may create an issue for designs that are required to operate at a higher typical voltage, such as 3.3V. To simplify system design, all devices in the PIC24FJ256GA705 family incorporate an on-chip regulator that allows the device to run its core logic from VDD.

This regulator is always enabled. It provides a constant voltage (1.8V nominal) to the digital core logic, from a VDD of about 2.1V, all the way up to the device's VDDMAX. It does not have the capability to boost VDD levels. In order to prevent "brown-out" conditions when the voltage drops too low for the regulator, the Brown-out Reset occurs. Then, the regulator output follows VDD with a typical voltage drop of 300 mV.

A low-ESR capacitor (such as ceramic) must be connected to the VCAP pin (Figure 29-1). This helps to maintain the stability of the regulator. The recommended value for the filter capacitor (CEFC) is provided in Section 32.1 "DC Characteristics".

FIGURE 29-1: CONNECTIONS FOR THE ON-CHIP REGULATOR

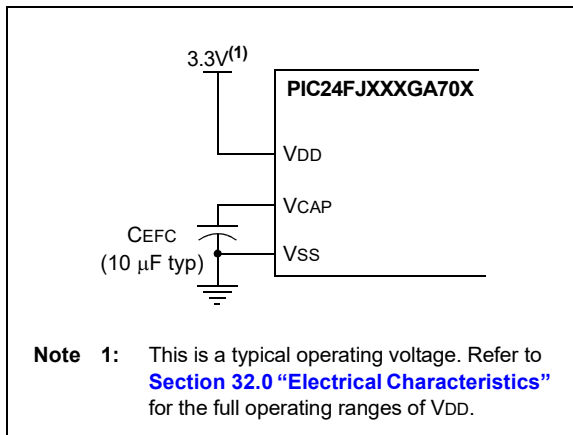

29.3.1 ON-CHIP REGULATOR AND POR

The voltage regulator takes approximately 10 μ s for it to generate output. During this time, designated as TVREG, code execution is disabled. TVREG is applied every time the device resumes operation after any power-down, including Sleep mode. TVREG is determined by the status of the VREGS bit (RCON[8]) and the WDTWIN[1:0] Configuration bits (FWDT[9:8]). Refer to Section 32.0 "Electrical Characteristics" for more information on TVREG.

Note: For more information, see Section 32.0 "Electrical Characteristics". The information in this data sheet supersedes the information in the FRM.

29.3.2 VOLTAGE REGULATOR STANDBY MODE

The on-chip regulator always consumes a small incremental amount of current over IDD/IPD, including when the device is in Sleep mode, even though the core digital logic does not require power. To provide additional savings in applications where power resources are critical, the regulator can be made to enter Standby mode, on its own, whenever the device goes into Sleep mode. This feature is controlled by the VREGS bit (RCON[8]). Clearing the VREGS bit enables the Standby mode. When waking up from Standby mode, the regulator needs to wait for TVREG to expire before wake-up.

29.3.3 LOW-VOLTAGE RETENTION REGULATOR

When in Sleep mode, PIC24FJ256GA705 family devices may use a separate low-power, low-voltage retention regulator to power critical circuits. This regulator, which operates at 1.2V nominal, maintains power to data RAM and the RTCC while all other core digital logic is powered down. The low-voltage retention regulator is described in more detail in Section 10.2.4 "Low-Voltage Retention Regulator".

PIC24FJ256GA705 FAMILY

29.4 Watchdog Timer (WDT)

For PIC24FJ256GA705 family devices, the WDT is driven by the LPRC Oscillator, the Secondary Oscillator (SOSC) or the system timer. When the device is in Sleep mode, the LPRC Oscillator will be used. When the WDT is enabled, the clock source is also enabled.

The nominal WDT clock source from LPRC is 31 kHz. This feeds a prescaler that can be configured for either 5-bit (divide-by-32) or 7-bit (divide-by-128) operation. The prescaler is set by the FWPSA Configuration bit. With a 31 kHz input, the prescaler yields a nominal WDT Time-out (TWDT) period of 1 ms in 5-bit mode or 4 ms in 7-bit mode.

A variable postscaler divides down the WDT prescaler output and allows for a wide range of time-out periods. The postscaler is controlled by the WDTPS[3:0] Configuration bits (FWDT[3:0]), which allows the selection of a total of 16 settings, from 1:1 to 1:32,768. Using the prescaler and postscaler time-out periods, ranges from 1 ms to 131 seconds can be achieved.

The WDT, prescaler and postscaler are reset:

- On any device Reset
- On the completion of a clock switch, whether invoked by software (i.e., setting the OSWEN bit after changing the NOSCx bits) or by hardware (i.e., Fail-Safe Clock Monitor)
- When a `PWRSVAV` instruction is executed (i.e., Sleep or Idle mode is entered)
- When the device exits Sleep or Idle mode to resume normal operation
- By a `CLRWDT` instruction during normal execution

If the WDT is enabled, it will continue to run during Sleep or Idle modes. When the WDT time-out occurs, the device will wake the device and code execution will continue from where the `PWRSVAV` instruction was executed. The corresponding SLEEP or IDLE (RCON[3:2]) bits will need to be cleared in software after the device wakes up.

The WDT Flag bit, WDTO (RCON[4]), is not automatically cleared following a WDT time-out. To detect subsequent WDT events, the flag must be cleared in software.

Note: The <code>CLRWDT</code> and <code>PWRSVAV</code> instructions clear the prescaler and postscaler counts when executed.

29.4.1 WINDOWED OPERATION

The Watchdog Timer has an optional Fixed Window mode of operation. In this Windowed mode, `CLRWDT` instructions can only reset the WDT during the last 1/4 of the programmed WDT period. A `CLRWDT` instruction executed before that window causes a WDT Reset, similar to a WDT time-out.

Windowed WDT mode is enabled by programming the WINDIS Configuration bit (FWDT[7]) to '0'.

29.4.2 CONTROL REGISTER

The WDT is enabled or disabled by the FWDTEN[1:0] Configuration bits (FWDT[6:5]). When the Configuration bits, FWDTEN[1:0] = 11, the WDT is always enabled.

The WDT can be optionally controlled in software when the Configuration bits, FWDTEN[1:0] = 10. When FWDTEN[1:0] = 00, the Watchdog Timer is always disabled. The WDT is enabled in software by setting the SWDTEN control bit (RCON[5]). The SWDTEN control bit is cleared on any device Reset. The software WDT option allows the user to enable the WDT for critical code segments and disable the WDT during non-critical code segments for maximum power savings.

FIGURE 29-2: WDT BLOCK DIAGRAM

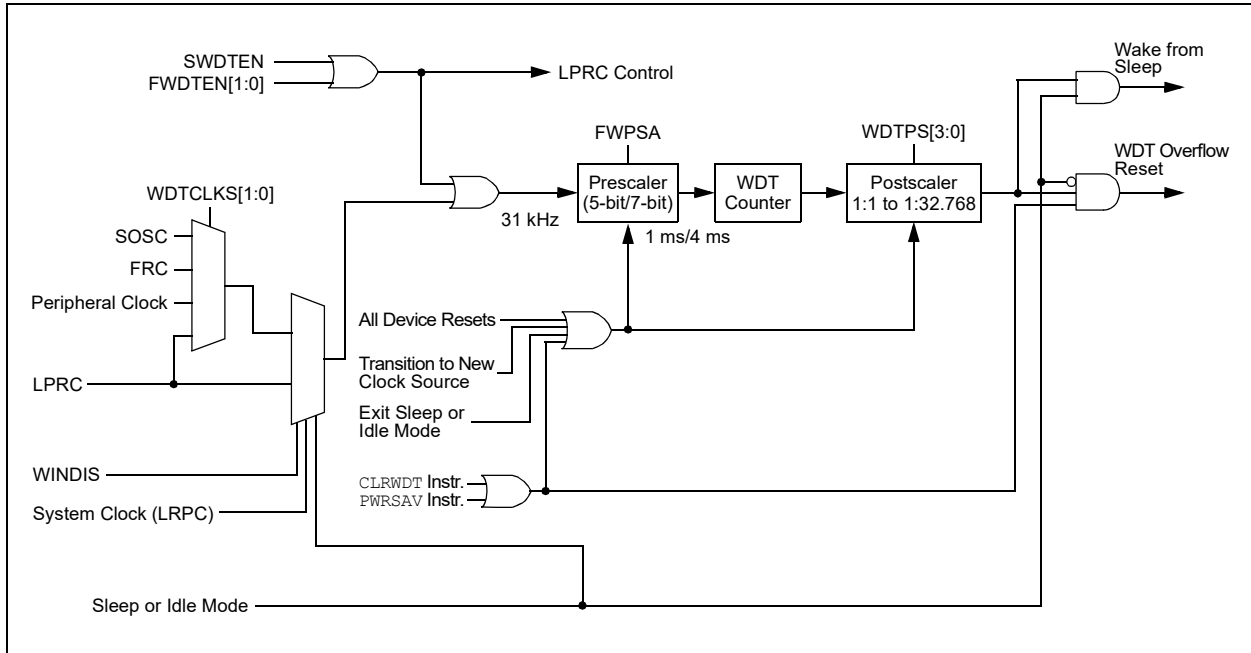

PIC24FJ256GA705 FAMILY

29.5 Program Verification and Code Protection

PIC24FJ256GA705 family devices offer basic implementation of CodeGuard™ Security that supports General Segment (GS) security and Boot Segment (BS) security. This feature helps protect individual intellectual property.

Note: For more information on usage, configuration and operation, refer to “CodeGuard™ Intermediate Security” (www.microchip.com/DS70005182) in the “dsPIC33/PIC24 Family Reference Manual”.

29.6 JTAG Interface

PIC24FJ256GA705 family devices implement a JTAG interface, which supports boundary scan device testing.

29.7 In-Circuit Serial Programming

PIC24FJ256GA705 family microcontrollers can be serially programmed while in the end application circuit. This is simply done with two lines for clock (PGCx) and data (PGDx), and three other lines for power (VDD), ground (Vss) and MCLR. This allows customers to manufacture boards with unprogrammed devices and then program the microcontroller just before shipping the product. This also allows the most recent firmware or a custom firmware to be programmed.

29.8 Customer OTP Memory

PIC24FJ256GA705 family devices provide 256 bytes of One-Time-Programmable (OTP) memory, located at addresses, 801700h through 8017FEh. This memory can be used for persistent storage of application-specific information that will not be erased by reprogramming the device. This includes many types of information, such as (but not limited to):

- Application checksums
- Code revision information
- Product information
- Serial numbers
- System manufacturing dates
- Manufacturing lot numbers

PIC24FJ256GA705 family devices provide 256 bytes of One-Time-Programmable (OTP) memory, and this OTP memory can be written by program execution (i.e., TBLWT instructions) and during device programming. Data are not cleared by a chip erase.

Note: Data in the OTP memory section MUST NOT be programmed more than once.

29.9 In-Circuit Debugger

This function allows simple debugging functions when used with MPLAB® IDE. Debugging functionality is controlled through the PGCx (Emulation/Debug Clock) and PGDx (Emulation/Debug Data) pins.

To use the in-circuit debugger function of the device, the design must implement ICSP™ connections to MCLR, VDD, Vss and the PGCx/PGDx pin pair, designated by the ICS[1:0] Configuration bits. In addition, when the feature is enabled, some of the resources are not available for general use. These resources include the first 80 bytes of data RAM and two I/O pins.

PIC24FJ256GA705 FAMILY

30.0 DEVELOPMENT SUPPORT

Move a design from concept to production in record time with Microchip's award-winning development tools. Microchip tools work together to provide state of the art debugging for any project with easy-to-use Graphical User Interfaces (GUIs) in our free MPLAB[®] X and Atmel Studio Integrated Development Environments (IDEs), and our code generation tools. Providing the ultimate ease-of-use experience, Microchip's line of programmers, debuggers and emulators work seamlessly with our software tools. Microchip development boards help evaluate the best silicon device for an application, while our line of third party tools round out our comprehensive development tool solutions.

Microchip's MPLAB X and Atmel Studio ecosystems provide a variety of embedded design tools to consider, which support multiple devices, such as PIC[®] MCUs, AVR[®] MCUs, SAM MCUs and dsPIC[®] DSCs. MPLAB X tools are compatible with Windows[®], Linux[®] and Mac[®] operating systems while Atmel Studio tools are compatible with Windows.

Go to the following website for more information and details:

<https://www.microchip.com/development-tools/>

PIC24FJ256GA705 FAMILY

NOTES:

31.0 INSTRUCTION SET SUMMARY

Note: This chapter is a brief summary of the PIC24F Instruction Set Architecture (ISA) and is not intended to be a comprehensive reference source.

The PIC24F instruction set adds many enhancements to the previous PIC[®] MCU instruction sets, while maintaining an easy migration from previous PIC MCU instruction sets. Most instructions are a single program memory word. Only three instructions require two program memory locations.

Each single-word instruction is a 24-bit word divided into an 8-bit opcode, which specifies the instruction type and one or more operands, which further specify the operation of the instruction. The instruction set is highly orthogonal and is grouped into four basic categories:

- Word or byte-oriented operations
- Bit-oriented operations
- Literal operations
- Control operations

Table 31-1 shows the general symbols used in describing the instructions. The PIC24F instruction set summary in Table 31-2 lists all the instructions, along with the status flags affected by each instruction.

Most word or byte-oriented W register instructions (including barrel shift instructions) have three operands:

- The first source operand, which is typically a register, 'Wb', without any address modifier
- The second source operand, which is typically a register, 'Ws', with or without an address modifier
- The destination of the result, which is typically a register, 'Wd', with or without an address modifier

However, word or byte-oriented file register instructions have two operands:

- The file register specified by the value, 'f'
- The destination, which could either be the file register, 'f', or the W0 register, which is denoted as 'WREG'

Most bit-oriented instructions (including simple rotate/shift instructions) have two operands:

- The W register (with or without an address modifier) or file register (specified by the value of 'Ws' or 'f')
- The bit in the W register or file register (specified by a literal value or indirectly by the contents of register, 'Wb')

The literal instructions that involve data movement may use some of the following operands:

- A literal value to be loaded into a W register or file register (specified by the value of 'k')
- The W register or file register where the literal value is to be loaded (specified by 'Wb' or 'f')

However, literal instructions that involve arithmetic or logical operations use some of the following operands:

- The first source operand, which is a register, 'Wb', without any address modifier
- The second source operand, which is a literal value
- The destination of the result (only if not the same as the first source operand), which is typically a register, 'Wd', with or without an address modifier

The control instructions may use some of the following operands:

- A program memory address
- The mode of the Table Read and Table Write instructions

All instructions are a single word, except for certain double-word instructions, which were made double-word instructions so that all the required information is available in these 48 bits. In the second word, the eight MSBs are '0's. If this second word is executed as an instruction (by itself), it will execute as a NOP.

Most single-word instructions are executed in a single instruction cycle, unless a conditional test is true or the Program Counter is changed as a result of the instruction. In these cases, the execution takes two instruction cycles, with the additional instruction cycle(s) executed as a NOP. Notable exceptions are the BRA (unconditional/computed branch), indirect CALL/GOTO, all Table Reads and Table Writes, and RETURN/RETfIE instructions, which are single-word instructions but take two or three cycles.

Certain instructions that involve skipping over the subsequent instruction require either two or three cycles if the skip is performed, depending on whether the instruction being skipped is a single-word or two-word instruction. Moreover, double-word moves require two cycles. The double-word instructions execute in two instruction cycles.

PIC24FJ256GA705 FAMILY

TABLE 31-1: SYMBOLS USED IN OPCODE DESCRIPTIONS

Field	Description
#text	Means literal defined by “text”
(text)	Means “content of text”
[text]	Means “the location addressed by text”
{ }	Optional field or operation
[n:m]	Register bit field
.b	Byte mode selection
.d	Double-Word mode selection
.S	Shadow register select
.w	Word mode selection (default)
bit4	4-bit Bit Selection field (used in word addressed instructions) $\in \{0..15\}$
C, DC, N, OV, Z	MCU Status bits: Carry, Digit Carry, Negative, Overflow, Sticky Zero
Expr	Absolute address, label or expression (resolved by the linker)
f	File register address $\in \{0000h..1FFFh\}$
lit1	1-bit unsigned literal $\in \{0,1\}$
lit4	4-bit unsigned literal $\in \{0..15\}$
lit5	5-bit unsigned literal $\in \{0..31\}$
lit8	8-bit unsigned literal $\in \{0..255\}$
lit10	10-bit unsigned literal $\in \{0..255\}$ for Byte mode, $\{0..1023\}$ for Word mode
lit14	14-bit unsigned literal $\in \{0..16383\}$
lit16	16-bit unsigned literal $\in \{0..65535\}$
lit23	23-bit unsigned literal $\in \{0..8388607\}$; LSb must be ‘0’
None	Field does not require an entry, may be blank
PC	Program Counter
Slit10	10-bit signed literal $\in \{-512..511\}$
Slit16	16-bit signed literal $\in \{-32768..32767\}$
Slit6	6-bit signed literal $\in \{-16..16\}$
Wb	Base W register $\in \{W0..W15\}$
Wd	Destination W register $\in \{Wd, [Wd], [Wd++] , [Wd--], [++Wd], [--Wd] \}$
Wdo	Destination W register $\in \{Wnd, [Wnd], [Wnd++] , [Wnd--], [++Wnd], [--Wnd], [Wnd+Wb] \}$
Wm,Wn	Dividend, Divisor Working register pair (direct addressing)
Wn	One of 16 Working registers $\in \{W0..W15\}$
Wnd	One of 16 destination Working registers $\in \{W0..W15\}$
Wns	One of 16 source Working registers $\in \{W0..W15\}$
WREG	W0 (Working register used in file register instructions)
Ws	Source W register $\in \{Ws, [Ws], [Ws++] , [Ws--], [++Ws], [--Ws] \}$
Wso	Source W register $\in \{Wns, [Wns], [Wns++] , [Wns--], [++Wns], [--Wns], [Wns+Wb] \}$

PIC24FJ256GA705 FAMILY

TABLE 31-2: INSTRUCTION SET OVERVIEW

Assembly Mnemonic	Assembly Syntax	Description	# of Words	# of Cycles	Status Flags Affected
ADD	ADD <i>f</i>	$f = f + WREG$	1	1	C, DC, N, OV, Z
	ADD <i>f</i> , <i>WREG</i>	$WREG = f + WREG$	1	1	C, DC, N, OV, Z
	ADD # <i>lit10</i> , <i>Wn</i>	$Wd = lit10 + Wd$	1	1	C, DC, N, OV, Z
	ADD <i>Wb</i> , <i>Ws</i> , <i>Wd</i>	$Wd = Wb + Ws$	1	1	C, DC, N, OV, Z
	ADD <i>Wb</i> , # <i>lit5</i> , <i>Wd</i>	$Wd = Wb + lit5$	1	1	C, DC, N, OV, Z
ADDC	ADDC <i>f</i>	$f = f + WREG + (C)$	1	1	C, DC, N, OV, Z
	ADDC <i>f</i> , <i>WREG</i>	$WREG = f + WREG + (C)$	1	1	C, DC, N, OV, Z
	ADDC # <i>lit10</i> , <i>Wn</i>	$Wd = lit10 + Wd + (C)$	1	1	C, DC, N, OV, Z
	ADDC <i>Wb</i> , <i>Ws</i> , <i>Wd</i>	$Wd = Wb + Ws + (C)$	1	1	C, DC, N, OV, Z
	ADDC <i>Wb</i> , # <i>lit5</i> , <i>Wd</i>	$Wd = Wb + lit5 + (C)$	1	1	C, DC, N, OV, Z
AND	AND <i>f</i>	$f = f .AND. WREG$	1	1	N, Z
	AND <i>f</i> , <i>WREG</i>	$WREG = f .AND. WREG$	1	1	N, Z
	AND # <i>lit10</i> , <i>Wn</i>	$Wd = lit10 .AND. Wd$	1	1	N, Z
	AND <i>Wb</i> , <i>Ws</i> , <i>Wd</i>	$Wd = Wb .AND. Ws$	1	1	N, Z
	AND <i>Wb</i> , # <i>lit5</i> , <i>Wd</i>	$Wd = Wb .AND. lit5$	1	1	N, Z
ASR	ASR <i>f</i>	$f = \text{Arithmetic Right Shift } f$	1	1	C, N, OV, Z
	ASR <i>f</i> , <i>WREG</i>	$WREG = \text{Arithmetic Right Shift } f$	1	1	C, N, OV, Z
	ASR <i>Ws</i> , <i>Wd</i>	$Wd = \text{Arithmetic Right Shift } Ws$	1	1	C, N, OV, Z
	ASR <i>Wb</i> , <i>Wns</i> , <i>Wnd</i>	$Wnd = \text{Arithmetic Right Shift } Wb \text{ by } Wns$	1	1	N, Z
	ASR <i>Wb</i> , # <i>lit5</i> , <i>Wnd</i>	$Wnd = \text{Arithmetic Right Shift } Wb \text{ by } lit5$	1	1	N, Z
BCLR	BCLR <i>f</i> , # <i>bit4</i>	Bit Clear <i>f</i>	1	1	None
	BCLR <i>Ws</i> , # <i>bit4</i>	Bit Clear <i>Ws</i>	1	1	None
BRA	BRA <i>C</i> , <i>Expr</i>	Branch if Carry	1	1 (2)	None
	BRA <i>GE</i> , <i>Expr</i>	Branch if Greater Than or Equal	1	1 (2)	None
	BRA <i>GEU</i> , <i>Expr</i>	Branch if Unsigned Greater Than or Equal	1	1 (2)	None
	BRA <i>GT</i> , <i>Expr</i>	Branch if Greater Than	1	1 (2)	None
	BRA <i>GTU</i> , <i>Expr</i>	Branch if Unsigned Greater Than	1	1 (2)	None
	BRA <i>LE</i> , <i>Expr</i>	Branch if Less Than or Equal	1	1 (2)	None
	BRA <i>LEU</i> , <i>Expr</i>	Branch if Unsigned Less Than or Equal	1	1 (2)	None
	BRA <i>LT</i> , <i>Expr</i>	Branch if Less Than	1	1 (2)	None
	BRA <i>LTU</i> , <i>Expr</i>	Branch if Unsigned Less Than	1	1 (2)	None
	BRA <i>N</i> , <i>Expr</i>	Branch if Negative	1	1 (2)	None
	BRA <i>NC</i> , <i>Expr</i>	Branch if Not Carry	1	1 (2)	None
	BRA <i>NN</i> , <i>Expr</i>	Branch if Not Negative	1	1 (2)	None
	BRA <i>NOV</i> , <i>Expr</i>	Branch if Not Overflow	1	1 (2)	None
	BRA <i>NZ</i> , <i>Expr</i>	Branch if Not Zero	1	1 (2)	None
	BRA <i>OV</i> , <i>Expr</i>	Branch if Overflow	1	1 (2)	None
	BRA <i>Expr</i>	Branch Unconditionally	1	2	None
	BRA <i>Z</i> , <i>Expr</i>	Branch if Zero	1	1 (2)	None
	BRA <i>Wn</i>	Computed Branch	1	2	None
BSET	BSET <i>f</i> , # <i>bit4</i>	Bit Set <i>f</i>	1	1	None
	BSET <i>Ws</i> , # <i>bit4</i>	Bit Set <i>Ws</i>	1	1	None
BSW	BSW.C <i>Ws</i> , <i>Wb</i>	Write C Bit to <i>Ws</i> [<i>Wb</i>]	1	1	None
	BSW.Z <i>Ws</i> , <i>Wb</i>	Write Z Bit to <i>Ws</i> [<i>Wb</i>]	1	1	None
BTG	BTG <i>f</i> , # <i>bit4</i>	Bit Toggle <i>f</i>	1	1	None
	BTG <i>Ws</i> , # <i>bit4</i>	Bit Toggle <i>Ws</i>	1	1	None
BTSC	BTSC <i>f</i> , # <i>bit4</i>	Bit Test <i>f</i> , Skip if Clear	1	1 (2 or 3)	None
	BTSC <i>Ws</i> , # <i>bit4</i>	Bit Test <i>Ws</i> , Skip if Clear	1	1 (2 or 3)	None

PIC24FJ256GA705 FAMILY

TABLE 31-2: INSTRUCTION SET OVERVIEW (CONTINUED)

Assembly Mnemonic	Assembly Syntax	Description	# of Words	# of Cycles	Status Flags Affected
BTSS	BTSS f, #bit4	Bit Test f, Skip if Set	1	1 (2 or 3)	None
	BTSS Ws, #bit4	Bit Test Ws, Skip if Set	1	1 (2 or 3)	None
BTST	BTST f, #bit4	Bit Test f	1	1	Z
	BTST.C Ws, #bit4	Bit Test Ws to C	1	1	C
	BTST.Z Ws, #bit4	Bit Test Ws to Z	1	1	Z
	BTST.C Ws, Wb	Bit Test Ws[Wb] to C	1	1	C
	BTST.Z Ws, Wb	Bit Test Ws[Wb] to Z	1	1	Z
BTSTS	BTSTS f, #bit4	Bit Test, then Set f	1	1	Z
	BTSTS.C Ws, #bit4	Bit Test Ws to C, then Set	1	1	C
	BTSTS.Z Ws, #bit4	Bit Test Ws to Z, then Set	1	1	Z
CALL	CALL lit23	Call Subroutine	2	2	None
	CALL Wn	Call Indirect Subroutine	1	2	None
CLR	CLR f	f = 0x0000	1	1	None
	CLR WREG	WREG = 0x0000	1	1	None
	CLR Ws	Ws = 0x0000	1	1	None
CLRWDT	CLRWDT	Clear Watchdog Timer	1	1	WDTO, Sleep
COM	COM f	f = \bar{f}	1	1	N, Z
	COM f, WREG	WREG = \bar{f}	1	1	N, Z
	COM Ws, Wd	Wd = \overline{Ws}	1	1	N, Z
CP	CP f	Compare f with WREG	1	1	C, DC, N, OV, Z
	CP Wb, #lit5	Compare Wb with lit5	1	1	C, DC, N, OV, Z
	CP Wb, Ws	Compare Wb with Ws (Wb – Ws)	1	1	C, DC, N, OV, Z
CP0	CP0 f	Compare f with 0x0000	1	1	C, DC, N, OV, Z
	CP0 Ws	Compare Ws with 0x0000	1	1	C, DC, N, OV, Z
CPB	CPB f	Compare f with WREG, with Borrow	1	1	C, DC, N, OV, Z
	CPB Wb, #lit5	Compare Wb with lit5, with Borrow	1	1	C, DC, N, OV, Z
	CPB Wb, Ws	Compare Wb with Ws, with Borrow (Wb – Ws – C)	1	1	C, DC, N, OV, Z
CPSEQ	CPSEQ Wb, Wn	Compare Wb with Wn, Skip if =	1	1 (2 or 3)	None
CPSGT	CPSGT Wb, Wn	Compare Wb with Wn, Skip if >	1	1 (2 or 3)	None
CPSLT	CPSLT Wb, Wn	Compare Wb with Wn, Skip if <	1	1 (2 or 3)	None
CPSNE	CPSNE Wb, Wn	Compare Wb with Wn, Skip if ≠	1	1 (2 or 3)	None
DAW	DAW.B Wn	Wn = Decimal Adjust Wn	1	1	C
DEC	DEC f	f = f – 1	1	1	C, DC, N, OV, Z
	DEC f, WREG	WREG = f – 1	1	1	C, DC, N, OV, Z
	DEC Ws, Wd	Wd = Ws – 1	1	1	C, DC, N, OV, Z
DEC2	DEC2 f	f = f – 2	1	1	C, DC, N, OV, Z
	DEC2 f, WREG	WREG = f – 2	1	1	C, DC, N, OV, Z
	DEC2 Ws, Wd	Wd = Ws – 2	1	1	C, DC, N, OV, Z
DISI	DISI #lit14	Disable Interrupts for k Instruction Cycles	1	1	None
DIV	DIV.SW Wm, Wn	Signed 16/16-Bit Integer Divide	1	18	N, Z, C, OV
	DIV.SD Wm, Wn	Signed 32/16-Bit Integer Divide	1	18	N, Z, C, OV
	DIV.UW Wm, Wn	Unsigned 16/16-Bit Integer Divide	1	18	N, Z, C, OV
	DIV.UD Wm, Wn	Unsigned 32/16-Bit Integer Divide	1	18	N, Z, C, OV
EXCH	EXCH Wns, Wnd	Swap Wns with Wnd	1	1	None
FF1L	FF1L Ws, Wnd	Find First One from Left (MSb) Side	1	1	C
FF1R	FF1R Ws, Wnd	Find First One from Right (LSb) Side	1	1	C

PIC24FJ256GA705 FAMILY

TABLE 31-2: INSTRUCTION SET OVERVIEW (CONTINUED)

Assembly Mnemonic	Assembly Syntax	Description	# of Words	# of Cycles	Status Flags Affected
GOTO	GOTO Expr	Go to Address	2	2	None
	GOTO Wn	Go to Indirect	1	2	None
INC	INC f	$f = f + 1$	1	1	C, DC, N, OV, Z
	INC f, WREG	WREG = f + 1	1	1	C, DC, N, OV, Z
	INC Ws, Wd	Wd = Ws + 1	1	1	C, DC, N, OV, Z
INC2	INC2 f	$f = f + 2$	1	1	C, DC, N, OV, Z
	INC2 f, WREG	WREG = f + 2	1	1	C, DC, N, OV, Z
	INC2 Ws, Wd	Wd = Ws + 2	1	1	C, DC, N, OV, Z
IOR	IOR f	$f = f .\text{IOR} .\text{WREG}$	1	1	N, Z
	IOR f, WREG	WREG = f .IOR. WREG	1	1	N, Z
	IOR #lit10, Wn	Wd = lit10 .IOR. Wd	1	1	N, Z
	IOR Wb, Ws, Wd	Wd = Wb .IOR. Ws	1	1	N, Z
	IOR Wb, #lit5, Wd	Wd = Wb .IOR. lit5	1	1	N, Z
LNK	LNK #lit14	Link Frame Pointer	1	1	None
LSR	LSR f	f = Logical Right Shift f	1	1	C, N, OV, Z
	LSR f, WREG	WREG = Logical Right Shift f	1	1	C, N, OV, Z
	LSR Ws, Wd	Wd = Logical Right Shift Ws	1	1	C, N, OV, Z
	LSR Wb, Wns, Wnd	Wnd = Logical Right Shift Wb by Wns	1	1	N, Z
	LSR Wb, #lit5, Wnd	Wnd = Logical Right Shift Wb by lit5	1	1	N, Z
MOV	MOV f, Wn	Move f to Wn	1	1	None
	MOV [Wns+Slit10], Wnd	Move [Wns+Slit10] to Wnd	1	1	None
	MOV f	Move f to f	1	1	N, Z
	MOV f, WREG	Move f to WREG	1	1	N, Z
	MOV #lit16, Wn	Move 16-Bit Literal to Wn	1	1	None
	MOV.b #lit8, Wn	Move 8-Bit Literal to Wn	1	1	None
	MOV Wn, f	Move Wn to f	1	1	None
	MOV Wns, [Wns+Slit10]	Move Wns to [Wns+Slit10]	1	1	None
	MOV Wso, Wdo	Move Ws to Wd	1	1	None
	MOV WREG, f	Move WREG to f	1	1	N, Z
	MOV.D Wns, Wd	Move Double from W(ns):W(ns+1) to Wd	1	2	None
	MOV.D Ws, Wnd	Move Double from Ws to W(nd+1):W(nd)	1	2	None
MUL	MUL.SS Wb, Ws, Wnd	{Wnd+1, Wnd} = Signed(Wb) * Signed(Ws)	1	1	None
	MUL.SU Wb, Ws, Wnd	{Wnd+1, Wnd} = Signed(Wb) * Unsigned(Ws)	1	1	None
	MUL.US Wb, Ws, Wnd	{Wnd+1, Wnd} = Unsigned(Wb) * Signed(Ws)	1	1	None
	MUL.UU Wb, Ws, Wnd	{Wnd+1, Wnd} = Unsigned(Wb) * Unsigned(Ws)	1	1	None
	MUL.SU Wb, #lit5, Wnd	{Wnd+1, Wnd} = Signed(Wb) * Unsigned(lit5)	1	1	None
	MUL.UU Wb, #lit5, Wnd	{Wnd+1, Wnd} = Unsigned(Wb) * Unsigned(lit5)	1	1	None
	MUL f	W3:W2 = f * WREG	1	1	None
NEG	NEG f	$f = \bar{f} + 1$	1	1	C, DC, N, OV, Z
	NEG f, WREG	WREG = $\bar{f} + 1$	1	1	C, DC, N, OV, Z
	NEG Ws, Wd	Wd = $\overline{Ws} + 1$	1	1	C, DC, N, OV, Z
NOP	NOP	No Operation	1	1	None
	NOPR	No Operation	1	1	None
POP	POP f	Pop f from Top-of-Stack (TOS)	1	1	None
	POP Wdo	Pop from Top-of-Stack (TOS) to Wdo	1	1	None
	POP.D Wnd	Pop from Top-of-Stack (TOS) to W(nd):W(nd+1)	1	2	None
	POP.S	Pop Shadow Registers	1	1	All
PUSH	PUSH f	Push f to Top-of-Stack (TOS)	1	1	None
	PUSH Wso	Push Wso to Top-of-Stack (TOS)	1	1	None
	PUSH.D Wns	Push W(ns):W(ns+1) to Top-of-Stack (TOS)	1	2	None
	PUSH.S	Push Shadow Registers	1	1	None

PIC24FJ256GA705 FAMILY

TABLE 31-2: INSTRUCTION SET OVERVIEW (CONTINUED)

Assembly Mnemonic	Assembly Syntax	Description	# of Words	# of Cycles	Status Flags Affected
PWRSVAV	PWRSVAV #lit1	Go into Sleep or Idle mode	1	1	WDTO, Sleep
RCALL	RCALL Expr	Relative Call	1	2	None
	RCALL Wn	Computed Call	1	2	None
REPEAT	REPEAT #lit14	Repeat Next Instruction lit14 + 1 Times	1	1	None
	REPEAT Wn	Repeat Next Instruction (Wn) + 1 Times	1	1	None
RESET	RESET	Software Device Reset	1	1	None
RETFIE	RETFIE	Return from Interrupt	1	3 (2)	None
RETLW	RETLW #lit10,Wn	Return with Literal in Wn	1	3 (2)	None
RETURN	RETURN	Return from Subroutine	1	3 (2)	None
RLC	RLC f	f = Rotate Left through Carry f	1	1	C, N, Z
	RLC f, WREG	WREG = Rotate Left through Carry f	1	1	C, N, Z
	RLC Ws, Wd	Wd = Rotate Left through Carry Ws	1	1	C, N, Z
RLNC	RLNC f	f = Rotate Left (No Carry) f	1	1	N, Z
	RLNC f, WREG	WREG = Rotate Left (No Carry) f	1	1	N, Z
	RLNC Ws, Wd	Wd = Rotate Left (No Carry) Ws	1	1	N, Z
RRC	RRC f	f = Rotate Right through Carry f	1	1	C, N, Z
	RRC f, WREG	WREG = Rotate Right through Carry f	1	1	C, N, Z
	RRC Ws, Wd	Wd = Rotate Right through Carry Ws	1	1	C, N, Z
RRNC	RRNC f	f = Rotate Right (No Carry) f	1	1	N, Z
	RRNC f, WREG	WREG = Rotate Right (No Carry) f	1	1	N, Z
	RRNC Ws, Wd	Wd = Rotate Right (No Carry) Ws	1	1	N, Z
SE	SE Ws, Wnd	Wnd = Sign-Extended Ws	1	1	C, N, Z
SETM	SETM f	f = FFFFh	1	1	None
	SETM WREG	WREG = FFFFh	1	1	None
	SETM Ws	Ws = FFFFh	1	1	None
SL	SL f	f = Left Shift f	1	1	C, N, OV, Z
	SL f, WREG	WREG = Left Shift f	1	1	C, N, OV, Z
	SL Ws, Wd	Wd = Left Shift Ws	1	1	C, N, OV, Z
	SL Wb, Wns, Wnd	Wnd = Left Shift Wb by Wns	1	1	N, Z
	SL Wb, #lit5, Wnd	Wnd = Left Shift Wb by lit5	1	1	N, Z
SUB	SUB f	f = f - WREG	1	1	C, DC, N, OV, Z
	SUB f, WREG	WREG = f - WREG	1	1	C, DC, N, OV, Z
	SUB #lit10, Wn	Wn = Wn - lit10	1	1	C, DC, N, OV, Z
	SUB Wb, Ws, Wd	Wd = Wb - Ws	1	1	C, DC, N, OV, Z
	SUB Wb, #lit5, Wd	Wd = Wb - lit5	1	1	C, DC, N, OV, Z
SUBB	SUBB f	f = f - WREG - (\overline{C})	1	1	C, DC, N, OV, Z
	SUBB f, WREG	WREG = f - WREG - (\overline{C})	1	1	C, DC, N, OV, Z
	SUBB #lit10, Wn	Wn = Wn - lit10 - (\overline{C})	1	1	C, DC, N, OV, Z
	SUBB Wb, Ws, Wd	Wd = Wb - Ws - (\overline{C})	1	1	C, DC, N, OV, Z
	SUBB Wb, #lit5, Wd	Wd = Wb - lit5 - (\overline{C})	1	1	C, DC, N, OV, Z
SUBR	SUBR f	f = WREG - f	1	1	C, DC, N, OV, Z
	SUBR f, WREG	WREG = WREG - f	1	1	C, DC, N, OV, Z
	SUBR Wb, Ws, Wd	Wd = Ws - Wb	1	1	C, DC, N, OV, Z
	SUBR Wb, #lit5, Wd	Wd = lit5 - Wb	1	1	C, DC, N, OV, Z
SUBBR	SUBBR f	f = WREG - f - (\overline{C})	1	1	C, DC, N, OV, Z
	SUBBR f, WREG	WREG = WREG - f - (\overline{C})	1	1	C, DC, N, OV, Z
	SUBBR Wb, Ws, Wd	Wd = Ws - Wb - (\overline{C})	1	1	C, DC, N, OV, Z
	SUBBR Wb, #lit5, Wd	Wd = lit5 - Wb - (\overline{C})	1	1	C, DC, N, OV, Z
SWAP	SWAP.b Wn	Wn = Nibble Swap Wn	1	1	None
	SWAP Wn	Wn = Byte Swap Wn	1	1	None

PIC24FJ256GA705 FAMILY

TABLE 31-2: INSTRUCTION SET OVERVIEW (CONTINUED)

Assembly Mnemonic	Assembly Syntax	Description	# of Words	# of Cycles	Status Flags Affected
TBLRDH	TBLRDH <i>Ws, Wd</i>	Read Prog[23:16] to Wd[7:0]	1	2	None
TBLRDL	TBLRDL <i>Ws, Wd</i>	Read Prog[15:0] to Wd	1	2	None
TBLWTH	TBLWTH <i>Ws, Wd</i>	Write Ws[7:0] to Prog[23:16]	1	2	None
TBLWTL	TBLWTL <i>Ws, Wd</i>	Write Ws to Prog[15:0]	1	2	None
ULNK	ULNK	Unlink Frame Pointer	1	1	None
XOR	XOR <i>f</i>	$f = f \text{ .XOR. WREG}$	1	1	N, Z
	XOR <i>f, WREG</i>	$WREG = f \text{ .XOR. WREG}$	1	1	N, Z
	XOR <i>#lit10, Wn</i>	$Wd = \text{lit10} \text{ .XOR. } Wd$	1	1	N, Z
	XOR <i>Wb, Ws, Wd</i>	$Wd = Wb \text{ .XOR. } Ws$	1	1	N, Z
	XOR <i>Wb, #lit5, Wd</i>	$Wd = Wb \text{ .XOR. lit5}$	1	1	N, Z
ZE	ZE <i>Ws, Wnd</i>	Wnd = Zero-Extend Ws	1	1	C, Z, N

PIC24FJ256GA705 FAMILY

NOTES:

32.0 ELECTRICAL CHARACTERISTICS

This section provides an overview of the PIC24FJ256GA705 family electrical characteristics. Additional information will be provided in future revisions of this document as it becomes available.

Absolute maximum ratings for the PIC24FJ256GA705 family are listed below. Exposure to these maximum rating conditions for extended periods may affect device reliability. Functional operation of the device at these, or any other conditions above the parameters indicated in the operation listings of this specification, is not implied.

Absolute Maximum Ratings^(†)

Ambient temperature under bias	-40°C to +125°C
Storage temperature	-65°C to +150°C
Voltage on VDD with respect to VSS	-0.3V to +4.0V
Voltage on any general purpose digital or analog pin (not 5.5V tolerant) with respect to VSS	-0.3V to (VDD + 0.3V)
Voltage on any general purpose digital or analog pin (5.5V tolerant, including MCLR) with respect to VSS:	
When VDD = 0V:	-0.3V to +4.0V
When VDD ≥ 2.0V:	-0.3V to +6.0V
Voltage on AVDD with respect to VSS	(VDD – 0.3V) to (lesser of: 4.0V or (VDD + 0.3V))
Voltage on AVSS with respect to VSS	-0.3V to +0.3V
Maximum current out of VSS pin	300 mA
Maximum current into VDD pin (Note 1)	250 mA
Maximum output current sunk by any I/O pin	25 mA
Maximum output current sourced by any I/O pin	25 mA
Maximum current sunk by all ports	200 mA
Maximum current sourced by all ports (Note 1)	200 mA

Note 1: Maximum allowable current is a function of device maximum power dissipation (see [Table 32-1](#)).

† **NOTICE:** Stresses above those listed under “Absolute Maximum Ratings” may cause permanent damage to the device. This is a stress rating only and functional operation of the device at those or any other conditions above those indicated in the operation listings of this specification is not implied. Exposure to maximum rating conditions for extended periods may affect device reliability.

PIC24FJ256GA705 FAMILY

32.1 DC Characteristics

FIGURE 32-1: PIC24FJ256GA705 FAMILY VOLTAGE-FREQUENCY GRAPH (INDUSTRIAL)

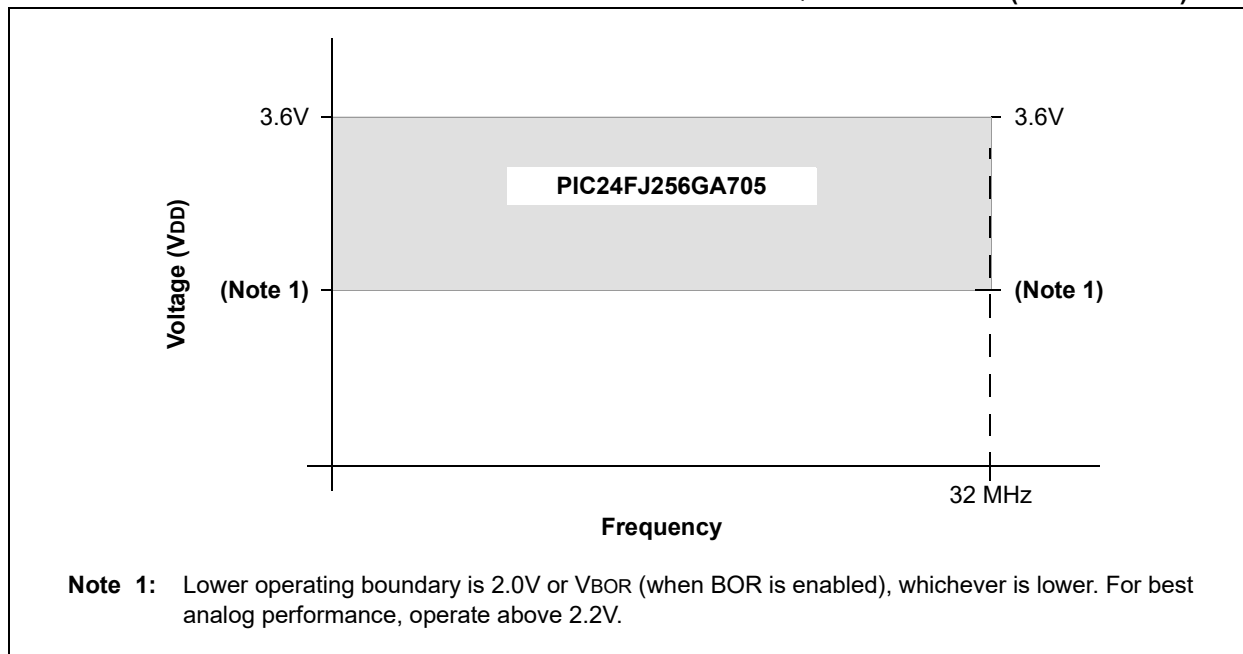

TABLE 32-1: THERMAL OPERATING CONDITIONS

Rating	Symbol	Min	Typ	Max	Unit
PIC24FJ256GA705:					
Operating Junction Temperature Range	T _J	-40	—	+125	°C
Operating Ambient Temperature Range	T _A	-40	—	+125	°C
Power Dissipation:					
Internal Chip Power Dissipation: P _{INT} = V _{DD} x (I _{DD} - Σ I _{OH})	P _D	P _{INT} + P _{I/O}			W
I/O Pin Power Dissipation: P _{I/O} = Σ ({V _{DD} - V _{OH} } x I _{OH}) + Σ (V _{OL} x I _{OL})					
Maximum Allowed Power Dissipation	P _D MAX	(T _J - T _A)/θ _{JA}			W

TABLE 32-2: THERMAL PACKAGING CHARACTERISTICS

Characteristic	Symbol	Typ	Max	Unit	Notes
Package Thermal Resistance, 6x6 mm 28-Pin QFN	θ _{JA}		—	°C/W	Note 1
Package Thermal Resistance, 4x4x0.6 mm 28-Pin UQFN	θ _{JA}		—	°C/W	Note 1
Package Thermal Resistance, 7.50 mm 28-Pin SOIC	θ _{JA}		—	°C/W	Note 1
Package Thermal Resistance, 5.30 mm 28-Pin SSOP	θ _{JA}		—	°C/W	Note 1
Package Thermal Resistance, 300 mil 28-Pin SPDIP	θ _{JA}		—	°C/W	Note 1
Package Thermal Resistance, 6x6x0.5 mm 48-Pin UQFN	θ _{JA}	33.7	—	°C/W	Note 1
Package Thermal Resistance, 10x10x1 mm 44-Pin TQFP	θ _{JA}	28	—	°C/W	Note 1
Package Thermal Resistance, 7x7x1 mm 48-Pin TQFP	θ _{JA}	39.3	—	°C/W	Note 1

Note 1: Junction to ambient thermal resistance; Theta-JA (θ_{JA}) numbers are achieved by package simulations.

PIC24FJ256GA705 FAMILY

TABLE 32-3: DC CHARACTERISTICS: TEMPERATURE AND VOLTAGE SPECIFICATIONS

DC CHARACTERISTICS			Standard Operating Conditions: 2.0V to 3.6V (unless otherwise stated) Operating temperature $-40^{\circ}\text{C} \leq T_A \leq +85^{\circ}\text{C}$ for Industrial $-40^{\circ}\text{C} \leq T_A \leq +125^{\circ}\text{C}$ for Extended				
Param No.	Symbol	Characteristic	Min	Typ	Max	Units	Conditions
Operating Voltage							
DC10	VDD	Supply Voltage	2.0	—	3.6	V	BOR is disabled
			VBOR	—	3.6	V	BOR is enabled
DC12	VDR	RAM Data Retention Voltage⁽¹⁾	Greater of: VPORREL or VBOR	—	—	V	VBOR is used only if BOR is enabled (BOREN = 1)
DC16	VPOR	VDD Start Voltage to Ensure Internal Power-on Reset Signal	VSS	—	—	V	Note 2
DC17A	SVDD	Recommended VDD Rise Rate to Ensure Internal Power-on Reset Signal	1V/20 ms	—	1V/10 μS	sec	Notes 2, 4
DC17B	VBOR	Brown-out Reset Voltage on VDD Transition, High-to-Low	2.0	2.1	2.2	V	Note 3

- Note 1:** This is the limit to which VDD may be lowered and the RAM contents will always be retained.
- 2:** If the VPOR or SVDD parameters are not met, or the application experiences slow power-down VDD ramp rates, it is recommended to enable and use BOR.
- 3:** On a rising VDD power-up sequence, application firmware execution begins at the higher of the VPORREL or VBOR level (when BOREN = 1).
- 4:** VDD rise times outside this window may not internally reset the processor and are not parametrically tested.

PIC24FJ256GA705 FAMILY

TABLE 32-4: DC CHARACTERISTICS: OPERATING CURRENT (IDD)

DC CHARACTERISTICS			Standard Operating Conditions: 2.0V to 3.6V (unless otherwise stated) Operating temperature $-40^{\circ}\text{C} \leq T_A \leq +85^{\circ}\text{C}$ for Industrial $-40^{\circ}\text{C} \leq T_A \leq +125^{\circ}\text{C}$ for Extended			
Parameter No.	Typical ⁽¹⁾	Max	Units	Operating Temperature	VDD	Conditions
Operating Current (IDD)⁽²⁾						
DC19d	230	365	μA	-40°C	2.0V	0.5 MIPS, Fosc = 1 MHz
DC19a	230	365	μA	$+25^{\circ}\text{C}$		
DC19b	230	365	μA	$+85^{\circ}\text{C}$		
DC19c	283	486	μA	$+125^{\circ}\text{C}$		
DC19d	250	365	μA	-40°C	3.3V	
DC19a	250	365	μA	$+25^{\circ}\text{C}$		
DC19b	250	365	μA	$+85^{\circ}\text{C}$		
DC19c	295	505	μA	$+125^{\circ}\text{C}$		
DC20d	430	640	μA	-40°C	2.0V	1 MIPS, Fosc = 2 MHz
DC20a	430	640	μA	$+25^{\circ}\text{C}$		
DC20b	430	640	μA	$+85^{\circ}\text{C}$		
DC20c	464	683	μA	$+125^{\circ}\text{C}$		
DC20d	440	640	μA	-40°C	3.3V	
DC20a	440	640	μA	$+25^{\circ}\text{C}$		
DC20b	440	640	μA	$+85^{\circ}\text{C}$		
DC20c	478	640	μA	$+125^{\circ}\text{C}$		
DC23d	1.5	2.4	mA	-40°C	2.0V	4 MIPS, Fosc = 8 MHz
DC23a	1.5	2.4	mA	$+25^{\circ}\text{C}$		
DC23b	1.5	2.4	mA	$+85^{\circ}\text{C}$		
DC23c	1.5	2.4	mA	$+125^{\circ}\text{C}$		
DC23d	1.65	2.4	mA	-40°C	3.3V	
DC23a	1.65	2.4	mA	$+25^{\circ}\text{C}$		
DC23b	1.65	2.4	mA	$+85^{\circ}\text{C}$		
DC23c	1.65	2.4	mA	$+125^{\circ}\text{C}$		
DC24d	6.1	7.7	mA	-40°C	2.0V	16 MIPS, Fosc = 32 MHz
DC24a	6.1	7.7	mA	$+25^{\circ}\text{C}$		
DC24b	6.1	7.7	mA	$+85^{\circ}\text{C}$		
DC24c	6.1	7.7	mA	$+125^{\circ}\text{C}$		
DC24d	6.3	7.7	mA	-40°C	3.3V	
DC24a	6.3	7.7	mA	$+25^{\circ}\text{C}$		
DC24b	6.3	7.7	mA	$+85^{\circ}\text{C}$		
DC24c	6.3	7.7	mA	$+125^{\circ}\text{C}$		

Note 1: Data in the "Typical" column are at 3.3V, $+25^{\circ}\text{C}$ unless otherwise stated. Typical parameters are for design guidance only and are not tested.

2: The test conditions for all IDD measurements are as follows: OSC1 driven with external square wave from rail-to-rail. All I/O pins are configured as outputs and driving low. MCLR = VDD; WDT and FSCM are disabled. CPU, program memory and data memory are operational. No peripheral modules are operating or being clocked (defined PMDx bits are all '1's). JTAG interface is disabled.

PIC24FJ256GA705 FAMILY

TABLE 32-4: DC CHARACTERISTICS: OPERATING CURRENT (IDD) (CONTINUED)

DC CHARACTERISTICS			Standard Operating Conditions: 2.0V to 3.6V (unless otherwise stated) Operating temperature -40°C ≤ TA ≤ +85°C for Industrial -40°C ≤ TA ≤ +125°C for Extended			
Parameter No.	Typical ⁽¹⁾	Max	Units	Operating Temperature	VDD	Conditions
Operating Current (IDD)⁽²⁾						
DC31d	43	130	μA	-40°C	2.0V	LPRC (15.5 KIPS), Fosc = 31 kHz
DC31a	43	130	μA	+25°C		
DC31b	43	130	μA	+85°C		
DC31c	106	294	μA	+125°C		
DC31d	46	130	μA	-40°C	3.3V	
DC31a	46	130	μA	+25°C		
DC31b	46	130	μA	+85°C		
DC31c	115	310	μA	+125°C		
DC32d	1.63	2.5	mA	-40°C	2.0V	FRC (4 MIPS), Fosc = 8 MHz
DC32a	1.63	2.5	mA	+25°C		
DC32b	1.63	2.5	mA	+85°C		
DC32c	1.63	2.5	mA	+125°C		
DC32d	1.65	2.5	mA	-40°C	3.3V	
DC32a	1.65	2.5	mA	+25°C		
DC32b	1.65	2.5	mA	+85°C		
DC32c	1.65	2.5	mA	+125°C		

Note 1: Data in the “Typical” column are at 3.3V, +25°C unless otherwise stated. Typical parameters are for design guidance only and are not tested.

2: The test conditions for all IDD measurements are as follows: OSC1 driven with external square wave from rail-to-rail. All I/O pins are configured as outputs and driving low. $\overline{MCLR} = VDD$; WDT and FSCM are disabled. CPU, program memory and data memory are operational. No peripheral modules are operating or being clocked (defined PMDx bits are all ‘1’s). JTAG interface is disabled.

PIC24FJ256GA705 FAMILY

TABLE 32-5: DC CHARACTERISTICS: IDLE CURRENT (I_{IDLE})

DC CHARACTERISTICS			Standard Operating Conditions: 2.0V to 3.6V (unless otherwise stated) Operating temperature -40°C ≤ TA ≤ +85°C for Industrial -40°C ≤ TA ≤ +125°C for Extended			
Parameter No.	Typical ⁽¹⁾	Max	Units	Operating Temperature	V _{DD}	Conditions
Idle Current (I_{IDLE})⁽²⁾						
DC40d	95	400	μA	-40°C	2.0V	1 MIPS, Fosc = 2 MHz
DC40a	95	400	μA	+25°C		
DC40b	95	400	μA	+85°C		
DC40c	167	400	μA	+125°C		
DC40d	105	400	μA	-40°C	3.3V	
DC40a	105	400	μA	+25°C		
DC40b	105	400	μA	+85°C		
DC40c	181	400	μA	+125°C		
DC43d	290	1200	μA	-40°C	2.0V	4 MIPS, Fosc = 8 MHz
DC43a	290	1200	μA	+25°C		
DC43b	290	1200	μA	+85°C		
DC43c	368	1200	μA	+125°C		
DC43d	315	1200	μA	-40°C	3.3V	
DC43a	315	1200	μA	+25°C		
DC43b	315	1200	μA	+85°C		
DC43c	398	1200	μA	+125°C		
DC47d	1.05	3.7	mA	-40°C	2.0V	16 MIPS, Fosc = 32 MHz
DC47a	1.05	3.7	mA	+25°C		
DC47b	1.05	3.7	mA	+85°C		
DC47c	1.16	3.7	mA	+125°C		
DC47d	1.16	3.7	mA	-40°C	3.3V	
DC47a	1.16	3.7	mA	+25°C		
DC47b	1.16	3.7	mA	+85°C		
DC47c	1.26	3.7	mA	+125°C		
DC50d	350	1100	μA	-40°C	2.0V	FRC (4 MIPS), Fosc = 8 MHz
DC50a	350	1100	μA	+25°C		
DC50b	350	1100	μA	+85°C		
DC50c	404	1100	μA	+125°C		
DC50d	360	1100	μA	-40°C	3.3V	
DC50a	360	1100	μA	+25°C		
DC50b	360	1100	μA	+85°C		
DC50c	413	1100	μA	+125°C		

Note 1: Data in the “Typical” column are at 3.3V, +25°C unless otherwise stated. Parameters are for design guidance only and are not tested.

2: Base I_{IDLE} current is measured with the core off, the clock on and all modules turned off. Peripheral Module Disable SFR registers are all ‘1’s. All I/O pins are configured as outputs and driven low. JTAG interface is disabled.

PIC24FJ256GA705 FAMILY

TABLE 32-5: DC CHARACTERISTICS: IDLE CURRENT (IDLE) (CONTINUED)

DC CHARACTERISTICS			Standard Operating Conditions: 2.0V to 3.6V (unless otherwise stated) Operating temperature: -40°C ≤ TA ≤ +85°C for Industrial -40°C ≤ TA ≤ +125°C for Extended			
Parameter No.	Typical ⁽¹⁾	Max	Units	Operating Temperature	VDD	Conditions
Idle Current (IDLE)⁽²⁾						
DC51d	29	110	μA	-40°C	2.0V	LPRC (15.5 KIPS), Fosc = 31 kHz
DC51a	29	110	μA	+25°C		
DC51b	29	110	μA	+85°C		
DC51c	102	289	μA	+125°C		
DC51d	33	110	μA	-40°C	3.3V	
DC51a	33	110	μA	+25°C		
DC51b	33	110	μA	+85°C		
DC51c	111	305	μA	+125°C		

Note 1: Data in the "Typical" column are at 3.3V, +25°C unless otherwise stated. Parameters are for design guidance only and are not tested.

- 2:** Base IDLE current is measured with the core off, the clock on and all modules turned off. Peripheral Module Disable SFR registers are all '1's. All I/O pins are configured as outputs and driven low. JTAG interface is disabled.

PIC24FJ256GA705 FAMILY

TABLE 32-6: DC CHARACTERISTICS: POWER-DOWN CURRENT (IPD)

DC CHARACTERISTICS			Standard Operating Conditions: 2.0V to 3.6V (unless otherwise stated)			
			Operating temperature			
			-40°C ≤ TA ≤ +85°C for Industrial			
			-40°C ≤ TA ≤ +125°C for Extended			
Parameter No.	Typical ⁽¹⁾	Max	Units	Operating Temperature	VDD	Conditions
Power-Down Current^(4,5)						
DC60	2.5	10	μA	-40°C	2.0V	Sleep ⁽²⁾
	3.2	10	μA	+25°C		
	11.5	45	μA	+85°C		
	46.1	205	μA	+125°C		
	3.2	10	μA	-40°C	3.3V	
	4.4	10	μA	+25°C		
	12.2	45	μA	+85°C		
	47.7	213	μA	+125°C		
DC61	165	—	nA	-40°C	2.0V	Low-Voltage Retention Sleep ⁽³⁾
	190	—	nA	+25°C		
	14.5	—	μA	+85°C		
	14.5	—	μA	+125°C		
	220	—	nA	-40°C	3.3V	
	300	—	nA	+25°C		
	15	—	μA	+85°C		
	15	—	μA	+125°C		

Note 1: Data in the “Typical” column are at 3.3V, +25°C unless otherwise stated. Parameters are for design guidance only and are not tested.

2: The retention low-voltage regulator is disabled; RETEN (RCON[12]) = 0, $\overline{\text{LPCFG}}$ (FPOR[2]) = 1.

3: The retention low-voltage regulator is enabled; RETEN (RCON[12]) = 1, $\overline{\text{LPCFG}}$ (FPOR[2]) = 0.

4: Base IPD is measured with all peripherals and clocks shut down. All I/Os are configured as outputs and driven low. WDT, BOR and JTAG are all disabled.

5: These currents are measured on the device containing the most memory in this family.

PIC24FJ256GA705 FAMILY

TABLE 32-7: DC CHARACTERISTICS: Δ CURRENT (BOR, WDT, HLVD, RTCC)⁽³⁾

DC CHARACTERISTICS			Standard Operating Conditions: 2.0V to 3.6V (unless otherwise stated) Operating temperature -40°C ≤ TA ≤ +85°C for Industrial -40°C ≤ TA ≤ +125°C for Extended			
Parameter No.	Typical ⁽¹⁾	Max	Units	Operating Temperature	VDD	Conditions
Incremental Current Brown-out Reset (ΔBOR)⁽²⁾						
DC25	3	5	μA	-40°C	2.0V	Δ BOR ⁽²⁾
	3	5	μA	+25°C		
	3	5	μA	+85°C		
	3	5	μA	+125°C		
	4	5	μA	-40°C	3.3V	
	4	5	μA	+25°C		
	4	5	μA	+85°C		
	4	5	μA	+125°C		
Incremental Current Watchdog Timer (ΔWDT)⁽²⁾						
DC71	220	1000	nA	-40°C	2.0V	Δ WDT ⁽²⁾
	220	1000	nA	+25°C		
	220	1000	nA	+85°C		
	578	1000	nA	+125°C		
	300	1000	nA	-40°C	3.3V	
	300	1000	nA	+25°C		
	300	1000	nA	+85°C		
	630	1000	nA	+125°C		
Incremental Current High/Low-Voltage Detect (ΔHLVD)⁽²⁾						
DC75	1.3	5	μA	-40°C	2.0V	Δ HLVD ⁽²⁾
	1.3	5	μA	+25°C		
	1.3	5	μA	+85°C		
	3.83	5	μA	+125°C		
	1.9	5	μA	-40°C	3.3V	
	1.9	5	μA	+25°C		
	1.9	5	μA	+85°C		
	4.68	5	μA	+125°C		

Note 1: Data in the "Typical" column are at 3.3V, +25°C unless otherwise stated. Parameters are for design guidance only and are not tested.

2: Incremental current while the module is enabled and running.

3: The Δ current is the additional current consumed when the module is enabled. This current should be added to the base IPD current. The current includes the selected clock source enabled for WDT and RTCC.

PIC24FJ256GA705 FAMILY

TABLE 32-7: DC CHARACTERISTICS: Δ CURRENT (BOR, WDT, HLVD, RTCC)⁽³⁾ (CONTINUED)

DC CHARACTERISTICS			Standard Operating Conditions: 2.0V to 3.6V (unless otherwise stated) Operating temperature -40°C ≤ TA ≤ +85°C for Industrial -40°C ≤ TA ≤ +125°C for Extended			
Parameter No.	Typical ⁽¹⁾	Max	Units	Operating Temperature	VDD	Conditions
Incremental Current Real-Time Clock and Calendar (ΔRTCC)⁽²⁾						
DC77	2.5	—	μA	-40°C to +85°C	2.0V	Δ RTCC (with SOSC enabled in Low-Power mode) ⁽²⁾
	3	—	μA	-40°C to +85°C	3.3V	
DC77A	350	1000	nA	-40°C	2.0V	Δ RTCC (with LPRC enabled) ⁽²⁾
	350	1000	nA	+25°C		
	350	1000	nA	+85°C		
	759	1000	nA	+125°C		
	400	1000	nA	-40°C	3.3V	
	400	1000	nA	+25°C		
	400	1000	nA	+85°C		
	786	1000	nA	+125°C		

- Note 1:** Data in the “Typical” column are at 3.3V, +25°C unless otherwise stated. Parameters are for design guidance only and are not tested.
- 2:** Incremental current while the module is enabled and running.
- 3:** The Δ current is the additional current consumed when the module is enabled. This current should be added to the base IPD current. The current includes the selected clock source enabled for WDT and RTCC.

PIC24FJ256GA705 FAMILY

TABLE 32-8: DC CHARACTERISTICS: I/O PIN INPUT SPECIFICATIONS

DC CHARACTERISTICS			Standard Operating Conditions: 2.0V to 3.6V (unless otherwise stated) Operating temperature -40°C ≤ TA ≤ +85°C for Industrial -40°C ≤ TA ≤ +125°C for Extended				
Param No.	Symbol	Characteristic	Min	Typ ⁽¹⁾	Max	Units	Conditions
	V _{IL}	Input Low Voltage⁽³⁾					
DI10		I/O Pins with ST Buffer	V _{SS}	—	0.2 V _{DD}	V	
DI11		I/O Pins with TTL Buffer	V _{SS}	—	0.15 V _{DD}	V	
DI15		MCLR	V _{SS}	—	0.2 V _{DD}	V	
DI16		OSCI (XT mode)	V _{SS}	—	0.2 V _{DD}	V	
DI17		OSCI (HS mode)	V _{SS}	—	0.2 V _{DD}	V	
DI18		I/O Pins with I ² C Buffer	V _{SS}	—	0.3 V _{DD}	V	
DI19		I/O Pins with SMBus Buffer	V _{SS}	—	0.8	V	SMBus is enabled
	V _{IH}	Input High Voltage⁽³⁾					
DI20		I/O Pins with ST Buffer: with Analog Functions, Digital Only	0.8 V _{DD} 0.8 V _{DD}	— —	V _{DD} 5.5	V V	
DI21		I/O Pins with TTL Buffer: with Analog Functions, Digital Only	0.25 V _{DD} + 0.8 0.25 V _{DD} + 0.8	— —	V _{DD} 5.5	V V	
DI25		MCLR	0.8 V _{DD}	—	V _{DD}	V	
DI26		OSCI (XT mode)	0.7 V _{DD}	—	V _{DD}	V	
DI27		OSCI (HS mode)	0.7 V _{DD}	—	V _{DD}	V	
DI28		I/O Pins with I ² C Buffer: with Analog Functions, Digital Only	0.7 V _{DD} 0.7 V _{DD}	— —	V _{DD} 5.5	V V	
DI29		I/O Pins with SMBus Buffer: with Analog Functions, Digital Only	2.1 2.1	— —	V _{DD} 5.5	V V	2.5V ≤ V _{PIN} ≤ V _{DD}
DI30	ICNPU	CN_x Pull-up Current	150	—	450	μA	V _{DD} = 3.3V, V _{PIN} = V _{SS}
DI30A	ICNPD	CN_x Pull-Down Current	230	—	500	μA	V _{DD} = 3.3V, V _{PIN} = V _{DD}
	I _{IL}	Input Leakage Current⁽²⁾					
DI50		I/O Ports	—	—	±1	μA	V _{SS} ≤ V _{PIN} ≤ V _{DD} , pin at high-impedance
DI51		Analog Input Pins	—	—	±1	μA	V _{SS} ≤ V _{PIN} ≤ V _{DD} , pin at high-impedance
DI55		MCLR	—	—	±1	μA	V _{SS} ≤ V _{PIN} ≤ V _{DD}
DI56		OSCI/CLKI	—	—	±1	μA	V _{SS} ≤ V _{PIN} ≤ V _{DD} , EC, XT and HS modes

Note 1: Data in the “Typ” column are at 3.3V, +25°C unless otherwise stated. Parameters are for design guidance only and are not tested.

2: Negative current is defined as current sourced by the pin.

3: Refer to [Table 1-1](#) for I/O pin buffer types.

PIC24FJ256GA705 FAMILY

TABLE 32-9: DC CHARACTERISTICS: I/O PIN OUTPUT SPECIFICATIONS

DC CHARACTERISTICS			Standard Operating Conditions: 2.0V to 3.6V (unless otherwise stated)				
			Operating temperature				
			-40°C ≤ TA ≤ +85°C for Industrial				
			-40°C ≤ TA ≤ +125°C for Extended				
Param No.	Symbol	Characteristic	Min	Typ ⁽¹⁾	Max	Units	Conditions
DO10	VOL	Output Low Voltage I/O Ports	—	—	0.4	V	IOL = 6.6 mA, VDD = 3.6V
			—	—	0.8	V	IOL = 18 mA, VDD = 3.6V
			—	—	0.35	V	IOL = 5.0 mA, VDD = 2V
DO16	OSCO/CLKO		—	—	0.18	V	IOL = 6.6 mA, VDD = 3.6V
			—	—	0.2	V	IOL = 5.0 mA, VDD = 2V
DO20	VOH	Output High Voltage I/O Ports	3.4	—	—	V	IOH = -3.0 mA, VDD = 3.6V
			3.25	—	—	V	IOH = -6.0 mA, VDD = 3.6V
			2.8	—	—	V	IOH = -18 mA, VDD = 3.6V
			1.65	—	—	V	IOH = -1.0 mA, VDD = 2V
			1.4	—	—	V	IOH = -3.0 mA, VDD = 2V
DO26	OSCO/CLKO		3.3	—	—	V	IOH = -6.0 mA, VDD = 3.6V
			1.85	—	—	V	IOH = -1.0 mA, VDD = 2V

Note 1: Data in the “Typ” column are at 3.3V, +25°C unless otherwise stated. Parameters are for design guidance only and are not tested.

TABLE 32-10: DC CHARACTERISTICS: PROGRAM MEMORY

DC CHARACTERISTICS			Standard Operating Conditions: 2.0V to 3.6V (unless otherwise stated)				
			Operating temperature				
			-40°C ≤ TA ≤ +85°C for Industrial				
			-40°C ≤ TA ≤ +125°C for Extended				
Param No.	Symbol	Characteristic	Min	Typ ⁽¹⁾	Max	Units	Conditions
		Program Flash Memory					
D130	EP	Cell Endurance	10000	—	—	E/W	-40°C to +85°C
D131	VPR	VDD for Read	VMIN	—	3.6	V	VMIN = Minimum operating voltage
D132B		VDD for Self-Timed Write	VMIN	—	3.6	V	VMIN = Minimum operating voltage
D133A	TIW	Self-Timed Word Write Cycle Time	—	20	—	µs	
		Self-Timed Row Write Cycle Time	—	1.5	—	ms	
D133B	TIE	Self-Timed Page Erase Time	20	—	40	ms	
D134	TRETD	Characteristic Retention	20	—	—	Year	If no other specifications are violated
D135	IDDP	Supply Current during Programming	—	5	—	mA	

Note 1: Data in the “Typ” column are at 3.3V, +25°C unless otherwise stated.

PIC24FJ256GA705 FAMILY

TABLE 32-11: INTERNAL VOLTAGE REGULATOR SPECIFICATIONS

Operating Conditions: -40°C < TA < +125°C (unless otherwise stated)							
Param No.	Symbol	Characteristics	Min	Typ	Max	Units	Comments
DVR	TVREG	Voltage Regulator Start-up Time	—	10	—	µs	VREGS = 0 with any POR or BOR
DVR10	VBG	Internal Band Gap Reference	1.14	1.2	1.26	V	
DVR11	TBG	Band Gap Reference Start-up Time	—	1	—	ms	
DVR20	VRGOUT	Regulator Output Voltage	1.6	1.8	2.0	V	VDD > 1.9V
DVR21	CEFC	External Filter Capacitor Value	10	—	—	µF	Series resistance < 3Ω recommended; < 5Ω required
DVR30	VLVR	Low-Voltage Regulator Output Voltage	—	1.2	—	V	RETEN = 1, LPCFG = 0

TABLE 32-12: HIGH/LOW-VOLTAGE DETECT CHARACTERISTICS

Operating Conditions: -40°C < TA < +85°C (unless otherwise stated)								
Param No.	Symbol	Characteristic	Min	Typ	Max	Units	Conditions	
DC18	VHLVD	HLVD Voltage on VDD Transition	HLVDL[3:0] = 0100 ⁽¹⁾	3.45	—	3.73	V	
			HLVDL[3:0] = 0101	3.25	—	3.58	V	
			HLVDL[3:0] = 0110	2.95	—	3.25	V	
			HLVDL[3:0] = 0111	2.75	—	3.04	V	
			HLVDL[3:0] = 1000	2.65	—	2.92	V	
			HLVDL[3:0] = 1001	2.45	—	2.70	V	
			HLVDL[3:0] = 1010	2.35	—	2.60	V	
			HLVDL[3:0] = 1011	2.25	—	2.49	V	
			HLVDL[3:0] = 1100	2.15	—	2.39	V	
			HLVDL[3:0] = 1101	2.08	—	2.28	V	
DC101	VTHL	HLVD Voltage on LVDIN Pin Transition	HLVDL[3:0] = 1111	—	1.20	—	V	
DC105	TONLVD	HLVD Module Enable Time	—	5	—	µs	From POR or HLVDEN = 1	

Note 1: Trip points for values of HLVD[3:0], from '0000' to '0011', are not implemented.

PIC24FJ256GA705 FAMILY

TABLE 32-13: COMPARATOR DC SPECIFICATIONS

Operating Conditions: 2.0V < VDD < 3.6V, -40°C < TA < +85°C (unless otherwise stated)							
Param No.	Symbol	Characteristic	Min	Typ	Max	Units	Comments
D300	VI _{OFF}	Input Offset Voltage	—	12	50	mV	Note 1
D301	VI _{CM}	Input Common-Mode Voltage	0	—	VDD	V	Note 1
D302	CMRR	Common-Mode Rejection Ratio	55	—	—	dB	Note 1
D306	I _{QCOMP}	AVDD Quiescent Current per Comparator	—	27	—	μA	Comparator is enabled
D307	T _{RESP}	Response Time	—	300	—	ns	Note 2
D308	T _{MC2OV}	Comparator Mode Change to Valid Output	—	—	10	μs	
D309	I _{DD}	Operating Supply Current	—	30	—	μA	AVDD = 3.3V

Note 1: Parameters are characterized but not tested.

Note 2: Measured with one input at VDD/2 and the other transitioning from VSS to VDD, 40 mV step, 15 mV overdrive.

TABLE 32-14: COMPARATOR VOLTAGE REFERENCE DC SPECIFICATIONS

Operating Conditions: 2.0V < VDD < 3.6V, -40°C < TA < +85°C (unless otherwise stated)							
Param No.	Symbol	Characteristic	Min	Typ	Max	Units	Comments
VR310	T _{SET}	Settling Time	—	—	10	μs	Note 1
VRD311	CVR _{AA}	Absolute Accuracy	-100	—	+100	mV	
VRD312	CVR _{UR}	Unit Resistor Value (R)	—	4.5	—	kΩ	

Note 1: Measures the interval while CVR[4:0] transitions from '11111' to '00000'.

TABLE 32-15: CTMU CURRENT SOURCE SPECIFICATIONS

DC CHARACTERISTICS			Standard Operating Conditions: 2.0V to 3.6V (unless otherwise stated)						
			Operating temperature						
			-40°C ≤ TA ≤ +85°C for Industrial						
			-40°C ≤ TA ≤ +125°C for Extended						
Param No.	Sym	Characteristic	Min	Typ ⁽¹⁾	Max	Units	Comments	Conditions	
DCT10	I _{OUT1}	CTMU Current Source, Base Range	—	550	—	nA	CTMUCON1L[1:0] = 00 ⁽²⁾	2.5V < VDD < VDDMAX	
DCT11	I _{OUT2}	CTMU Current Source, 10x Range	—	5.5	—	μA	CTMUCON1L[1:0] = 01		
DCT12	I _{OUT3}	CTMU Current Source, 100x Range	—	55	—	μA	CTMUCON1L[1:0] = 10		
DCT13	I _{OUT4}	CTMU Current Source, 1000x Range	—	550	—	μA	CTMUCON1L[1:0] = 11 ⁽²⁾ , CTMUCON1H[0] = 0		
DCT14	I _{OUT5}	CTMU Current Source, High Range	—	2.2	—	mA	CTMUCON1L[1:0] = 01, CTMUCON1H[0] = 1		
DCT21	V _{DELTA1}	Temperature Diode Voltage Change per Degree Celsius	—	-1.8	—	mV/°C	Current = 5.5 μA		
DCT22	V _{DELTA2}	Temperature Diode Voltage Change per Degree Celsius	—	-1.55	—	mV/°C	Current = 55 μA		
DCT23	VD1	Forward Voltage	—	710	—	mV	At 0°C, 5.5 μA		
DCT24	VD2	Forward Voltage	—	760	—	mV	At 0°C, 55 μA		

Note 1: Nominal value at center point of current trim range (CTMUCON1L[7:2] = 000000).

Note 2: Do not use this current range with the internal temperature sensing diode.

PIC24FJ256GA705 FAMILY

32.2 AC Characteristics and Timing Parameters

The information contained in this section defines the PIC24FJ256GA705 family AC characteristics and timing parameters.

TABLE 32-16: TEMPERATURE AND VOLTAGE SPECIFICATIONS – AC

AC CHARACTERISTICS	Standard Operating Conditions: 2.0V to 3.6V (unless otherwise stated)	
	Operating temperature	-40°C ≤ TA ≤ +85°C for Industrial -40°C ≤ TA ≤ +125°C for Extended
	Operating voltage VDD range as described in Section 32.1 “DC Characteristics” .	

FIGURE 32-2: LOAD CONDITIONS FOR DEVICE TIMING SPECIFICATIONS

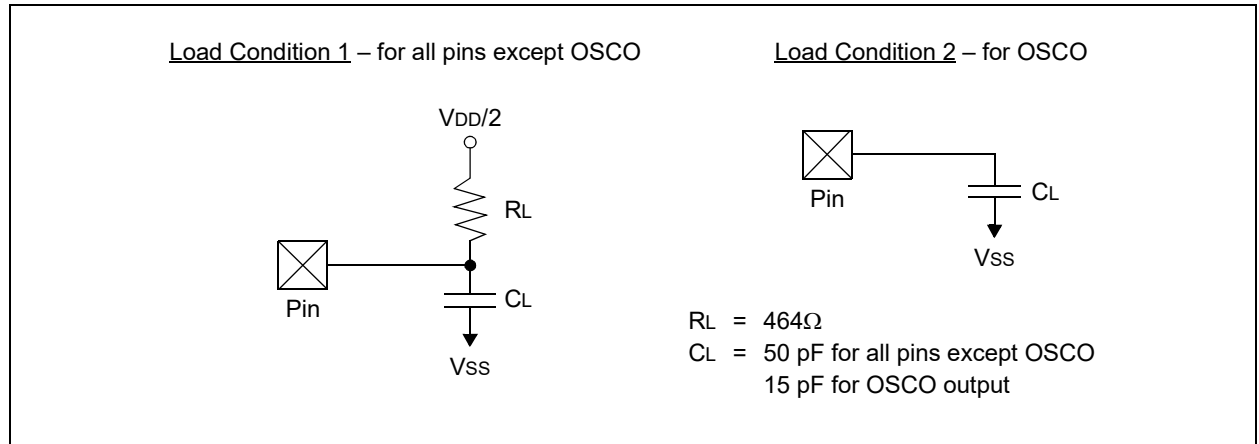

TABLE 32-17: CAPACITIVE LOADING REQUIREMENTS ON OUTPUT PINS

Param No.	Symbol	Characteristic	Min	Typ ⁽¹⁾	Max	Units	Conditions
DO50	Cosco	OSCO/CLKO Pin	—	—	15	pF	In XT and HS modes when external clock is used to drive OSC1
DO56	Cio	All I/O Pins and OSCO	—	—	50	pF	EC mode
DO58	CB	SCLx, SDAx	—	—	400	pF	In I ² C mode

Note 1: Data in the “Typ” column are at 3.3V, +25°C unless otherwise stated. Parameters are for design guidance only and are not tested.

PIC24FJ256GA705 FAMILY

FIGURE 32-3: EXTERNAL CLOCK TIMING

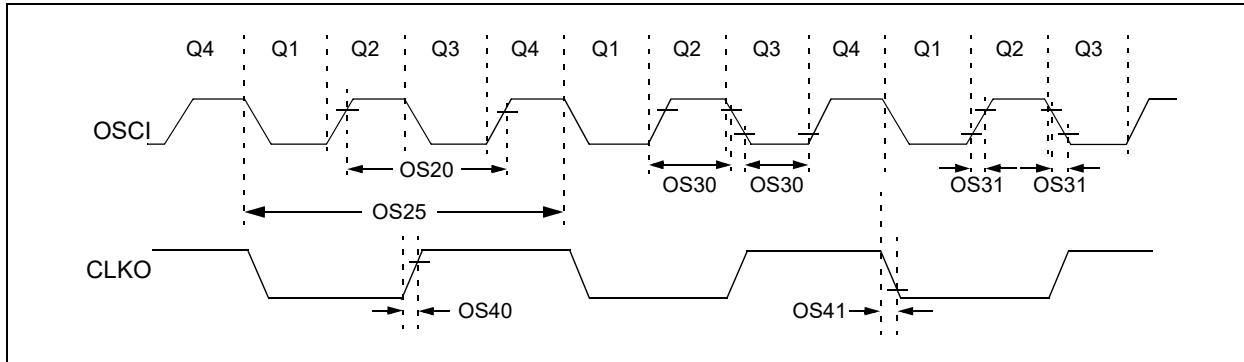

TABLE 32-18: EXTERNAL CLOCK TIMING REQUIREMENTS

AC CHARACTERISTICS			Standard Operating Conditions: 2.0V to 3.6V (unless otherwise stated) Operating temperature -40°C ≤ TA ≤ +85°C for Industrial -40°C ≤ TA ≤ +125°C for Extended					
Param No.	Symbol	Characteristic	Min	Typ ⁽¹⁾	Max	Units	Conditions	
OS10	Fosc	External CLKI Frequency (External clocks allowed only in EC mode)	DC 4	— —	32 48	MHz MHz	EC ECPLL (Note 2)	
		Oscillator Frequency	3.5 4 10 12 31	— — — — —	10 8 32 24 33	MHz MHz MHz MHz kHz	XT XTPLL HS HSPLL SOSC	
		Tosc = 1/Fosc	—	—	—	—	—	See Parameter OS10 for Fosc value
		TcY	Instruction Cycle Time ⁽³⁾	62.5	—	DC	ns	
		TosL, TosH	External Clock in (OSCI) High or Low Time	0.45 x Tosc	—	—	ns	EC
OS31	TosR, TosF	External Clock in (OSCI) Rise or Fall Time	—	—	20	ns	EC	
OS40	TckR	CLKO Rise Time ⁽⁴⁾	—	15	30	ns		
OS41	TckF	CLKO Fall Time ⁽⁴⁾	—	15	30	ns		

Note 1: Data in the “Typ” column are at 3.3V, +25°C unless otherwise stated. Parameters are for design guidance only and are not tested.

2: Represents input to the system clock prescaler. PLL dividers and postscalers must still be configured so that the system clock frequency does not exceed the maximum frequency shown in Figure 32-1.

3: Instruction cycle period (TcY) equals two times the input oscillator time base period. All specified values are based on characterization data for that particular oscillator type, under standard operating conditions, with the device executing code. Exceeding these specified limits may result in an unstable oscillator operation and/or higher than expected current consumption. All devices are tested to operate at “Min” values with an external clock applied to the OSCI/CLKI pin. When an external clock input is used, the “Max” cycle time limit is “DC” (no clock) for all devices.

4: Measurements are taken in EC mode. The CLKO signal is measured on the OSCO pin. CLKO is low for the Q1-Q2 period (1/2 TcY) and high for the Q3-Q4 period (1/2 TcY).

PIC24FJ256GA705 FAMILY

TABLE 32-19: AC SPECIFICATIONS FOR PHASE-LOCKED LOOP MODE

AC CHARACTERISTICS		Standard Operating Conditions: 2.0V to 3.6V (unless otherwise stated) Operating temperature -40°C ≤ TA ≤ +85°C for Industrial -40°C ≤ TA ≤ +125°C for Extended				
Sym	Characteristic	Min	Typ	Max	Units	Conditions
FIN	Input Frequency Range	2	—	24	MHz	
FMIN	Minimum Output Frequency from the Frequency Multiplier	—	—	16	MHz	4 MHz FIN with 4x feedback ratio, 2 MHz FIN with 8x feedback ratio
FMAX	Maximum Output Frequency from the Frequency Multiplier	96	—	—	MHz	4 MHz FIN with 24x net multiplication ratio, 24 MHz FIN with 4x net multiplication ratio
FSLEW	Maximum Step Function of FIN at which the PLL will be Ensured to Maintain Lock	-4	—	+4	%	Full input range of FIN
TLOCK	Lock Time for VCO	—	—	24	μs	With the specified minimum, TREF, and a lock timer count of one cycle, this is the maximum VCO lock time supported
JFM8	Cumulative Jitter of Frequency Multiplier Over Voltage and Temperature during Any Eight Consecutive Cycles of the PLL Output	—	—	±0.12	%	4 MHz FIN with 4x feedback ratio

TABLE 32-20: INTERNAL RC ACCURACY

AC CHARACTERISTICS		Standard Operating Conditions: 2.0V to 3.6V (unless otherwise stated) Operating temperature -40°C ≤ TA ≤ +85°C for Industrial -40°C ≤ TA ≤ +125°C for Extended				
Param No.	Characteristic	Min	Typ	Max	Units	Conditions
F20	FRC Accuracy @ 8 MHz	-1.5	+0.15	1.5	%	2.0V ≤ VDD ≤ 3.6V, 0°C ≤ TA ≤ +85°C (Note 1)
		-2	—	2	%	2.0V ≤ VDD ≤ 3.6V, -40°C ≤ TA ≤ 0°C
		-4	—	4	%	2.0V ≤ VDD ≤ 3.6V, +85°C ≤ TA ≤ 125°C
F21	LPRC @ 31 kHz	-20	—	20	%	VCAP Output Voltage = 1.8V
F22	OSCTUN Step-Size	—	0.1	—	%/bit	

Note 1: To achieve this accuracy, physical stress applied to the microcontroller package (ex., by flexing the PCB) must be kept to a minimum.

TABLE 32-21: RC OSCILLATOR START-UP TIME

AC CHARACTERISTICS			Standard Operating Conditions: 2.0V to 3.6V (unless otherwise stated) Operating temperature -40°C ≤ TA ≤ +85°C for Industrial -40°C ≤ TA ≤ +125°C for Extended				
Param No.	Symbol	Characteristic	Min	Typ	Max	Units	Conditions
FR0	T _{FRC}	FRC Oscillator Start-up Time	—	15	—	μs	
FR1	T _{LPRC}	Low-Power RC Oscillator Start-up Time	—	50	—	μs	

PIC24FJ256GA705 FAMILY

FIGURE 32-4: CLKO AND I/O TIMING CHARACTERISTICS

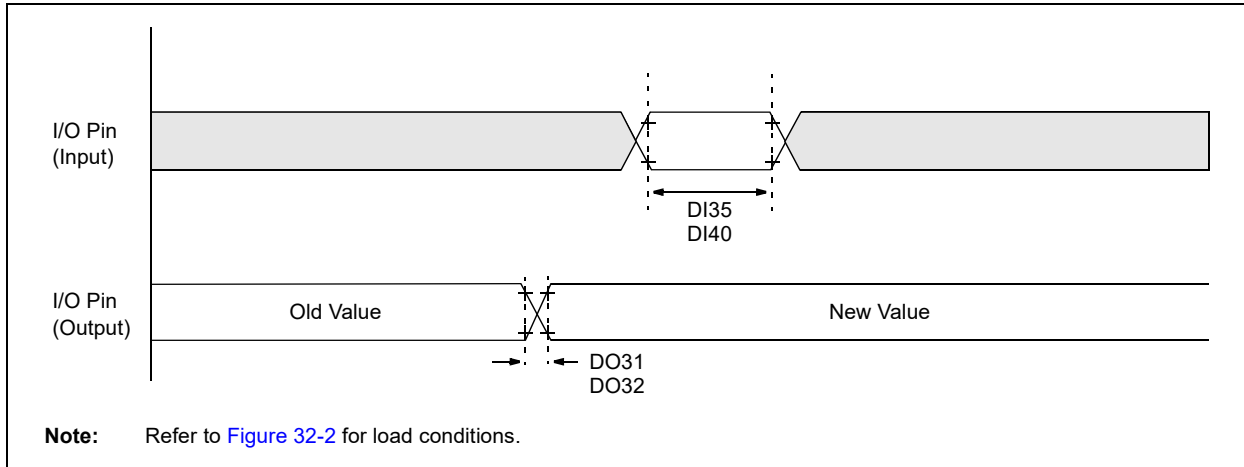

TABLE 32-22: CLKO AND I/O TIMING REQUIREMENTS

AC CHARACTERISTICS			Standard Operating Conditions: 2.0V to 3.6V (unless otherwise stated)				
			Operating temperature				
			-40°C ≤ TA ≤ +85°C for Industrial				
			-40°C ≤ TA ≤ +125°C for Extended				
Param No.	Symbol	Characteristic	Min	Typ ⁽¹⁾	Max	Units	Conditions
DO31	TioR	Port Output Rise Time	—	10	25	ns	
DO32	TioF	Port Output Fall Time	—	10	25	ns	
DI35	TINP	INTx Pin High or Low Time (input)	1	—	—	TcY	
DI40	TRBP	CNx High or Low Time (input)	1	—	—	TcY	

Note 1: Data in the "Typ" column are at 3.3V, +25°C unless otherwise stated.

PIC24FJ256GA705 FAMILY

TABLE 32-23: RESET AND BROWN-OUT RESET REQUIREMENTS

AC CHARACTERISTICS			Standard Operating Conditions: 2.0V to 3.6V (unless otherwise stated)				
			Operating temperature				
			-40°C ≤ TA ≤ +85°C for Industrial				
			-40°C ≤ TA ≤ +125°C for Extended				
Param No.	Symbol	Characteristic	Min	Typ	Max	Units	Conditions
SY10	TMCL	MCLR Pulse Width (Low)	2	—	—	μs	
SY12	TPOR	Power-on Reset Delay	—	2	—	μs	
SY13	TIOZ	I/O High-Impedance from MCLR Low or Watchdog Timer Reset	Lesser of: (3 Tcy + 2) or 700	—	(3 Tcy + 2)	μs	
SY25	TBOR	Brown-out Reset Pulse Width	1	—	—	μs	VDD ≤ VBOR
SY45	TRST	Internal State Reset Time	—	50	—	μs	
SY71	TPM	Program Memory Wake-up Time	—	20	—	μs	Sleep wake-up with VREGS = 1
			—	1	—	μs	Sleep wake-up with VREGS = 0
SY72	TLVR	Low-Voltage Regulator Wake-up Time	—	90	—	μs	Sleep wake-up with VREGS = 1
			—	70	—	μs	Sleep wake-up with VREGS = 0

PIC24FJ256GA705 FAMILY

FIGURE 32-5: TIMER1 EXTERNAL CLOCK TIMING CHARACTERISTICS

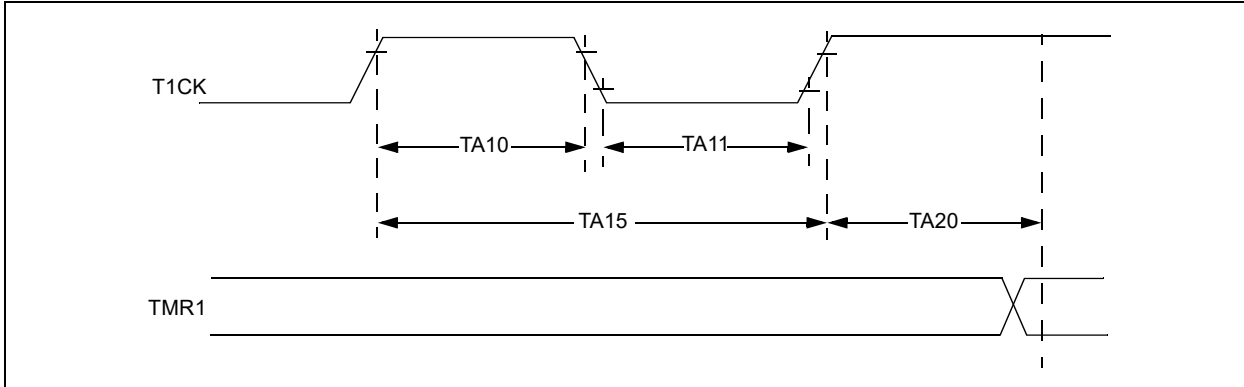

TABLE 32-24: TIMER1 EXTERNAL CLOCK TIMING CHARACTERISTICS

Operating Conditions (unless otherwise stated):							
2.0V < VDD < 3.6V,							
-40°C ≤ TA ≤ +85°C for Industrial,							
-40°C ≤ TA ≤ +125°C for Extended							
Param. No.	Symbol	Characteristics ⁽¹⁾	Min	Max	Units	Conditions	
TA10	TCKH	T1CK High Time	Synchronous	1	—	TcY	Must also meet Parameter TA15
		Asynchronous	10	—	ns		
TA11	TCKL	T1CK Low Time	Synchronous	1	—	TcY	Must also meet Parameter TA15
		Asynchronous	10	—	ns		
TA15	TCKP	T1CK Input Period	Synchronous	2	—	TcY	
		Asynchronous	20	—	ns		
TA20	TCKEXTMRL	Delay from External T1CK Clock Edge to Timer Increment	—	3	TcY	Synchronous mode	

Note 1: These parameters are characterized but not tested in manufacturing.

FIGURE 32-6: INPUT CAPTURE x TIMINGS

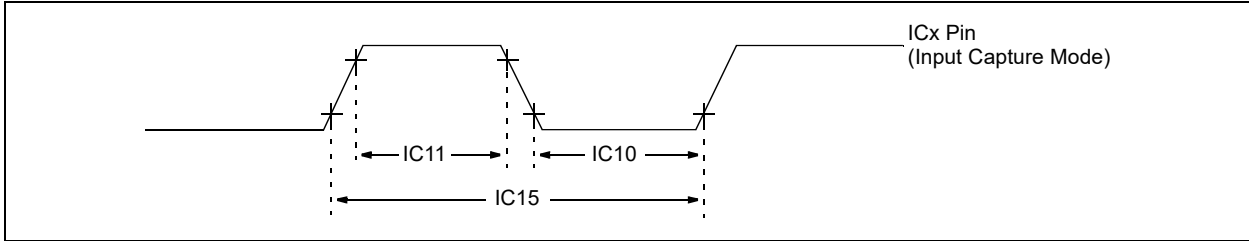

TABLE 32-25: INPUT CAPTURE x CHARACTERISTICS

Operating Conditions (unless otherwise stated):
 2.0V < V_{DD} < 3.6V,
 -40°C ≤ T_A ≤ +85°C for Industrial,
 -40°C ≤ T_A ≤ +125°C for Extended

Param. No.	Symbol	Characteristic ⁽¹⁾	Min	Max	Units	Conditions	
IC10	TccL	ICx Input Low Time – Synchronous Timer	No Prescaler	T _{CY} + 20	—	ns	Must also meet Parameter IC15
		With Prescaler	20	—	ns		
IC11	TccH	ICx Input Low Time – Synchronous Timer	No Prescaler	T _{CY} + 20	—	ns	Must also meet Parameter IC15
		With Prescaler	20	—	ns		
IC15	TccP	ICx Input Period – Synchronous Timer	$\frac{2 * T_{CY} + 40}{N}$	—	ns	N = Prescale Value (1, 4, 16)	

Note 1: These parameters are characterized but not tested in manufacturing.

FIGURE 32-7: PWM MODULE TIMING REQUIREMENTS

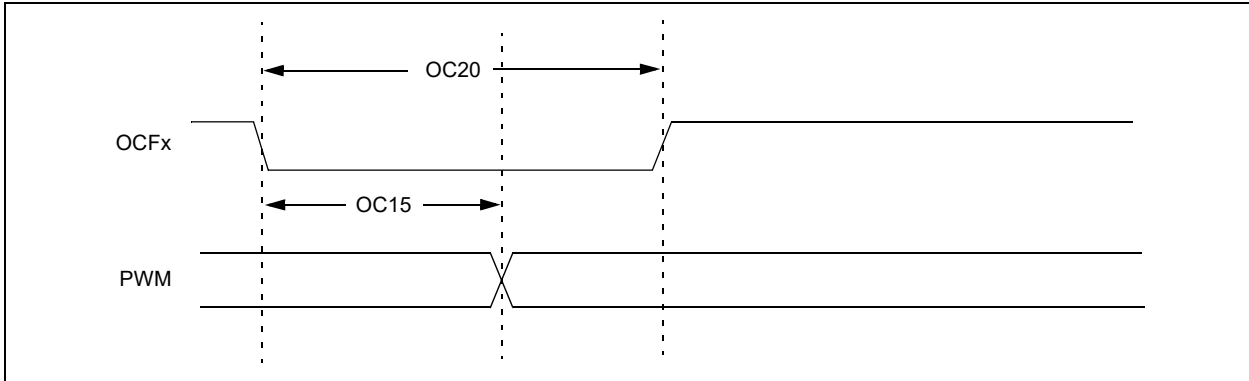

TABLE 32-26: PWM TIMING REQUIREMENTS

Operating Conditions (unless otherwise stated):
 2.0V < V_{DD} < 3.6V,
 -40°C ≤ T_A ≤ +85°C for Industrial,
 -40°C ≤ T_A ≤ +125°C for Extended

Param. No.	Symbol	Characteristic ⁽¹⁾	Min	Max	Units
OC15	TFD	Fault Input to PWM I/O Change	—	25	ns
OC20	TFH	Fault Input Pulse Width	50	—	ns

Note 1: These parameters are characterized but not tested in manufacturing.

PIC24FJ256GA705 FAMILY

FIGURE 32-8: MCCP/SCCP TIMER MODE EXTERNAL CLOCK TIMING CHARACTERISTICS

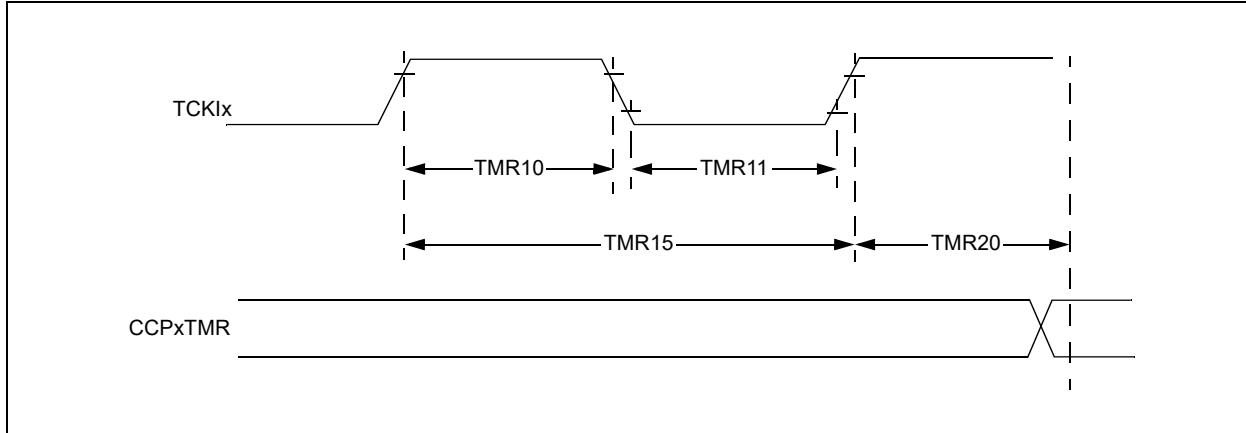

TABLE 32-27: MCCP/SCCP TIMER MODE TIMING REQUIREMENTS

Operating Conditions (unless otherwise stated): 2.0V < VDD < 3.6V, -40°C ≤ TA ≤ +85°C for Industrial, -40°C ≤ TA ≤ +125°C for Extended							
Param. No.	Symbol	Characteristics ⁽¹⁾		Min	Max	Units	Conditions
TMR10	TCKH	TCKIx High Time	Synchronous	1	—	Tcy	Must also meet Parameter TMR15
			Asynchronous	10	—	ns	
TMR11	TCKL	TCKIx Low Time	Synchronous	1	—	Tcy	Must also meet Parameter TMR15
			Asynchronous	10	—	ns	
TMR15	TCKP	TCKIx Input Period	Synchronous	2	—	Tcy	
			Asynchronous	20	—	ns	
TMR20	TCKEXTMRL	Delay from External TCKIx Clock Edge to Timer Increment		—	1	Tcy	

Note 1: These parameters are characterized but not tested in manufacturing.

FIGURE 32-9: MCCP/SCCP INPUT CAPTURE x MODE TIMING CHARACTERISTICS

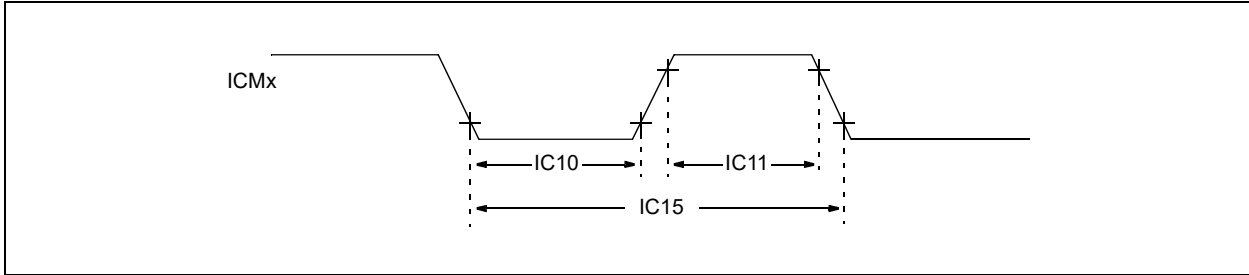

TABLE 32-28: MCCP/SCCP INPUT CAPTURE x MODE TIMING REQUIREMENTS

Operating Conditions (unless otherwise stated):
 $2.0V < V_{DD} < 3.6V$,
 $-40^{\circ}C \leq T_A \leq +85^{\circ}C$ for Industrial,
 $-40^{\circ}C \leq T_A \leq +125^{\circ}C$ for Extended

Param. No.	Symbol	Characteristics ⁽¹⁾	Min	Max	Units	Conditions
IC10	TICL	ICMx Input Low Time	25	—	ns	Must also meet Parameter IC15
IC11	TICH	ICMx Input High Time	25	—	ns	Must also meet Parameter IC15
IC15	TICP	ICMx Input Period	50	—	ns	

Note 1: These parameters are characterized but not tested in manufacturing.

FIGURE 32-10: MCCP/SCCP PWM MODE TIMING CHARACTERISTICS

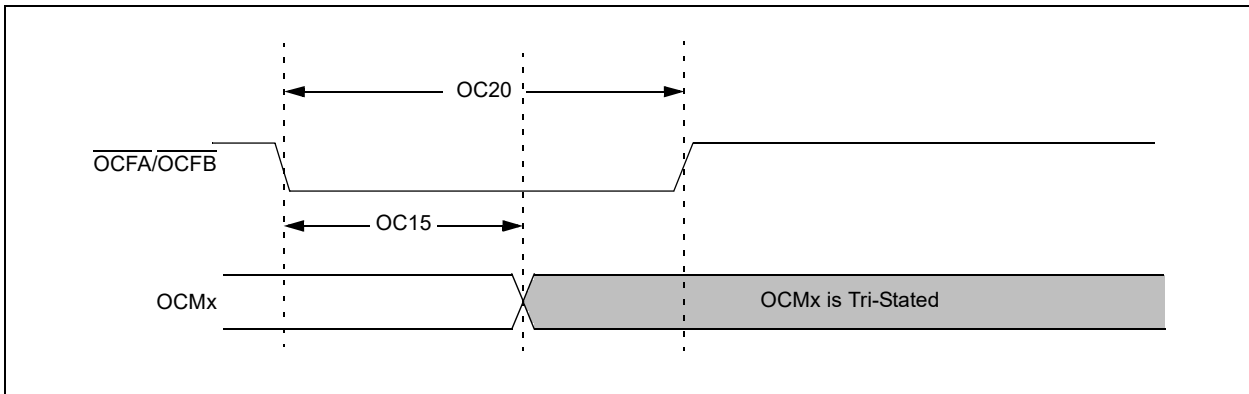

TABLE 32-29: MCCP/SCCP PWM MODE TIMING REQUIREMENTS

Operating Conditions (unless otherwise stated):
 $2.0V < V_{DD} < 3.6V$,
 $-40^{\circ}C \leq T_A \leq +85^{\circ}C$ for Industrial,
 $-40^{\circ}C \leq T_A \leq +125^{\circ}C$ for Extended

Param No.	Symbol	Characteristics ⁽¹⁾	Min	Max	Units
OC15	TFD	Fault Input to PWM I/O Change	—	30	ns
OC20	TFLT	Fault Input Pulse Width	10	—	ns

Note 1: These parameters are characterized but not tested in manufacturing.

PIC24FJ256GA705 FAMILY

FIGURE 32-11: SPIx MODULE MASTER MODE (CKE = 0) TIMING CHARACTERISTICS

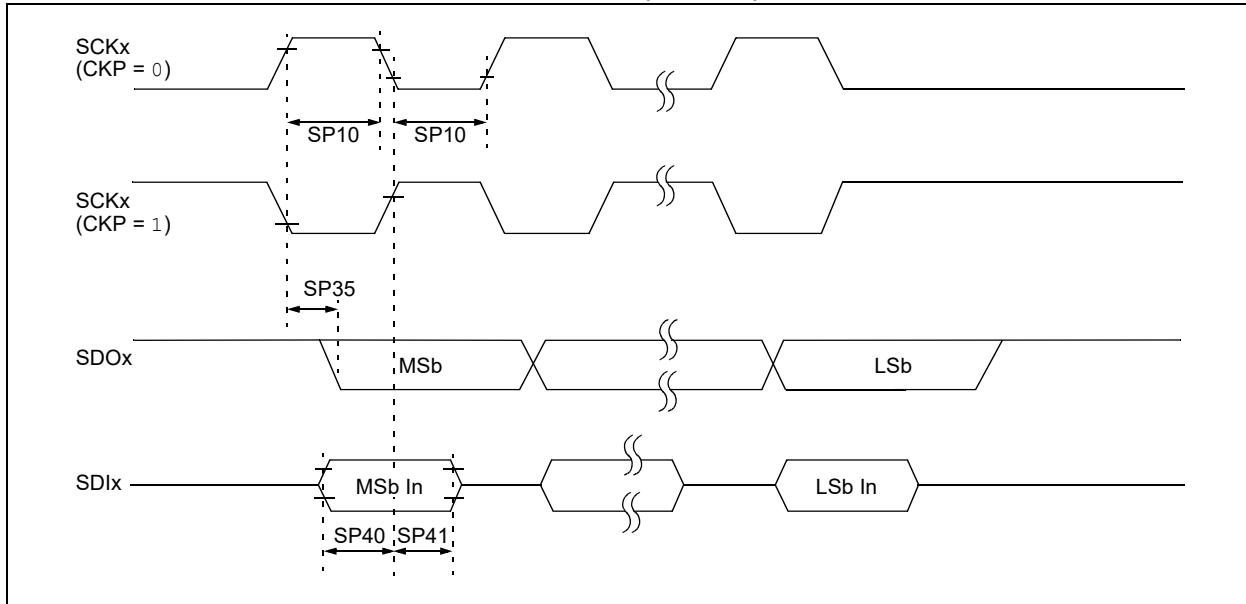

FIGURE 32-12: SPIx MODULE MASTER MODE (CKE = 1) TIMING CHARACTERISTICS

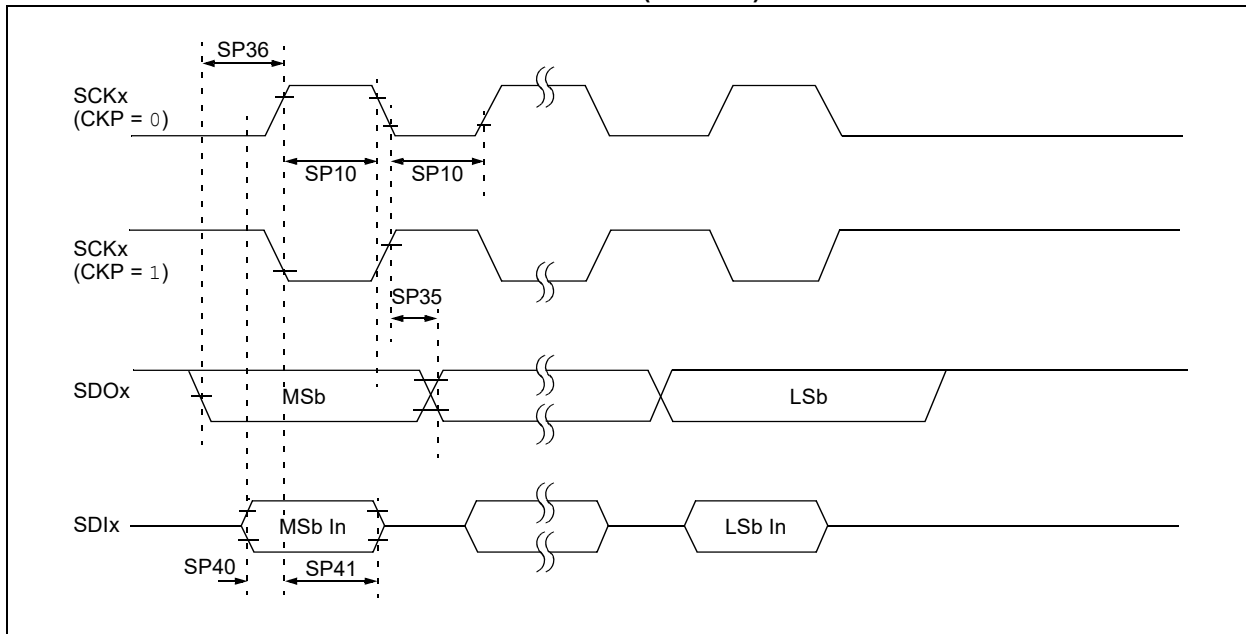

TABLE 32-30: SPIx MODULE MASTER MODE TIMING REQUIREMENTS

Operating Conditions (unless otherwise stated): 2.0V < VDD < 3.6V, -40°C ≤ TA ≤ +85°C for Industrial, -40°C ≤ TA ≤ +125°C for Extended					
Param. No.	Symbol	Characteristics⁽¹⁾	Min	Max	Units
SP10	TsCL, TschH	SCKx Output Low or High Time	20	—	ns
SP35	Tsch2DoV, TsCL2DoV	SDOx Data Output Valid after SCKx Edge	—	7	ns
SP36	TDoV2sc, TDoV2sCL	SDOx Data Output Setup to First SCKx Edge	7	—	ns
SP40	TdIV2sch, TdIV2sCL	Setup Time of SDIx Data Input to SCKx Edge	7	—	ns
SP41	Tsch2dIL, TsCL2dIL	Hold Time of SDIx Data Input to SCKx Edge	7	—	ns

Note 1: These parameters are characterized but not tested in manufacturing.

PIC24FJ256GA705 FAMILY

FIGURE 32-13: SPIx MODULE SLAVE MODE (CKE = 0) TIMING CHARACTERISTICS

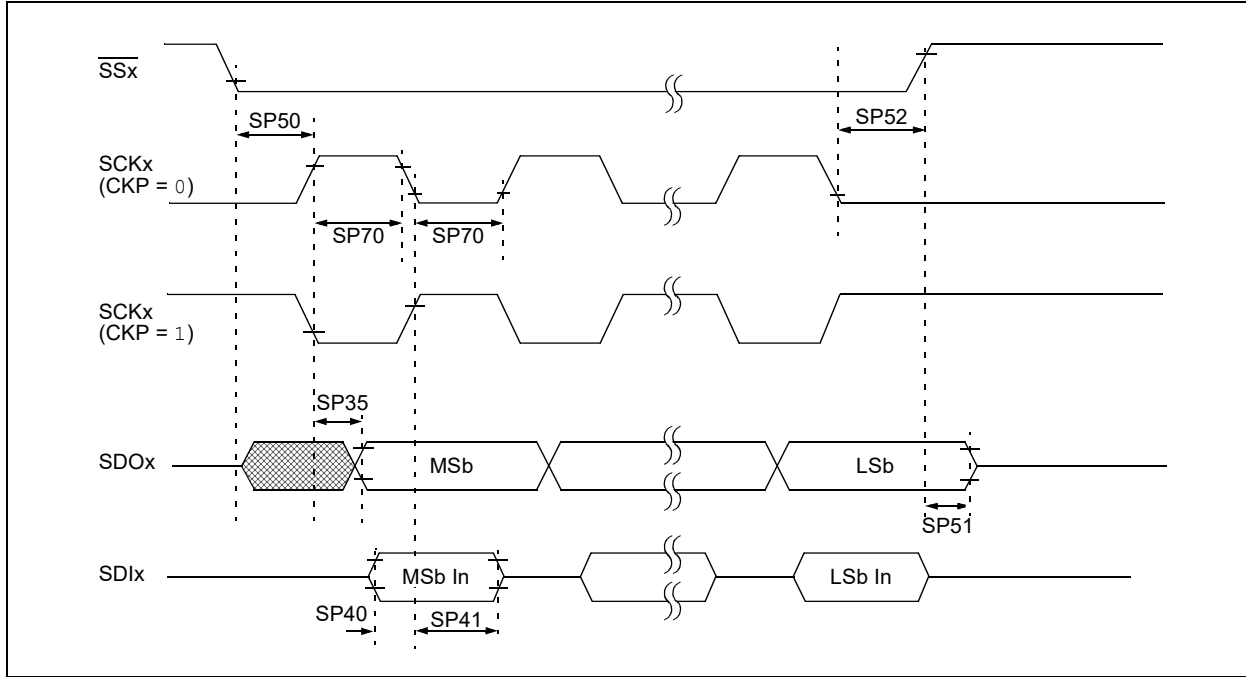
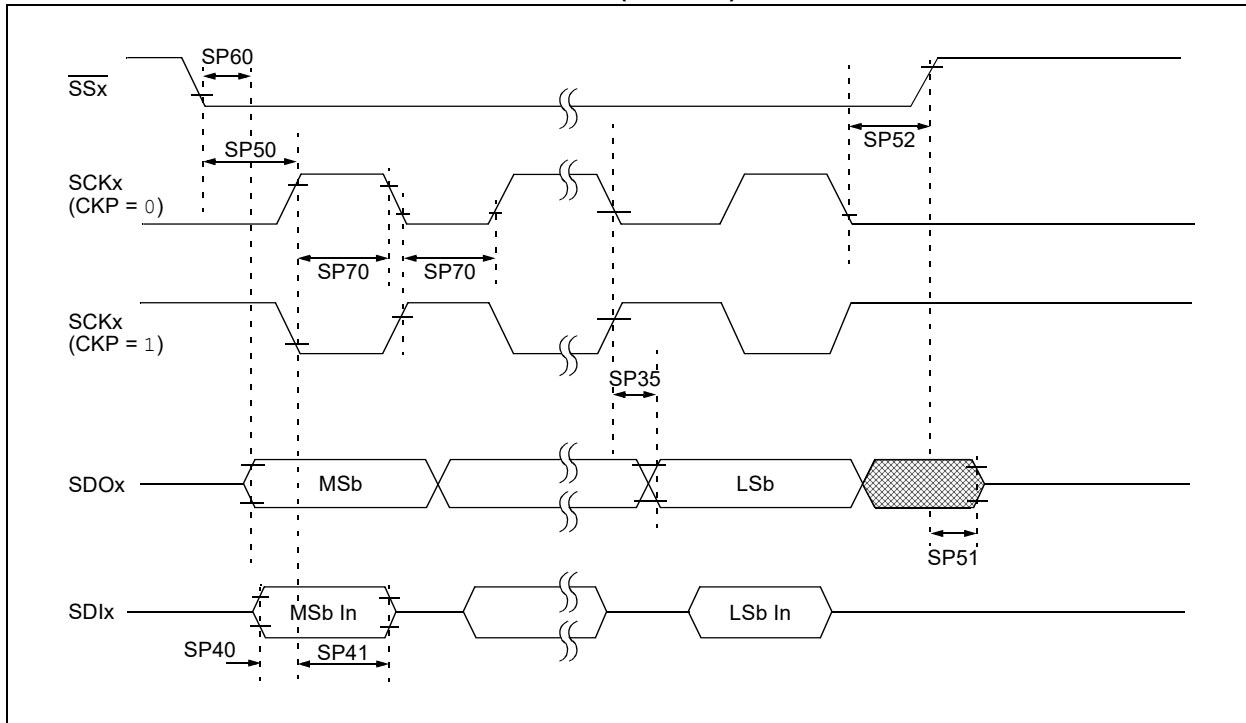

FIGURE 32-14: SPIx MODULE SLAVE MODE (CKE = 1) TIMING CHARACTERISTICS



PIC24FJ256GA705 FAMILY

TABLE 32-31: SPIx MODULE SLAVE MODE TIMING REQUIREMENTS

Operating Conditions (unless otherwise stated): 2.0V < V _{DD} < 3.6V, -40°C ≤ T _A ≤ +85°C for Industrial, -40°C ≤ T _A ≤ +125°C for Extended					
Param.No.	Symbol	Characteristics⁽¹⁾	Min	Max	Units
SP70	TscL, Tsch	SCKx Input Low Time or High Time	20	—	ns
SP35	Tsch2doV, TscL2doV	SDOx Data Output Valid after SCKx Edge	—	10	ns
SP40	TdiV2scH, TdiV2scL	Setup Time of SDIx Data Input to SCKx Edge	0	—	ns
SP41	Tsch2diL, TscL2diL	Hold Time of SDIx Data Input to SCKx Edge	7	—	ns
SP50	Tssl2scH, Tssl2scL	$\overline{SSx} \downarrow$ to SCKx \downarrow or SCKx \uparrow Input	40	—	ns
SP51	TssH2doZ	$\overline{SSx} \uparrow$ to SDOx Output High-Impedance	2.5	12	ns
SP52	Tsch2ssH TscL2ssH	$\overline{SSx} \uparrow$ after SCKx Edge	10	—	ns
SP60	Tssl2doV	SDOx Data Output Valid after \overline{SSx} Edge	—	12.5	ns

Note 1: These parameters are characterized but not tested in manufacturing.

PIC24FJ256GA705 FAMILY

FIGURE 32-15: I2Cx BUS START/STOP BITS TIMING CHARACTERISTICS (MASTER MODE)

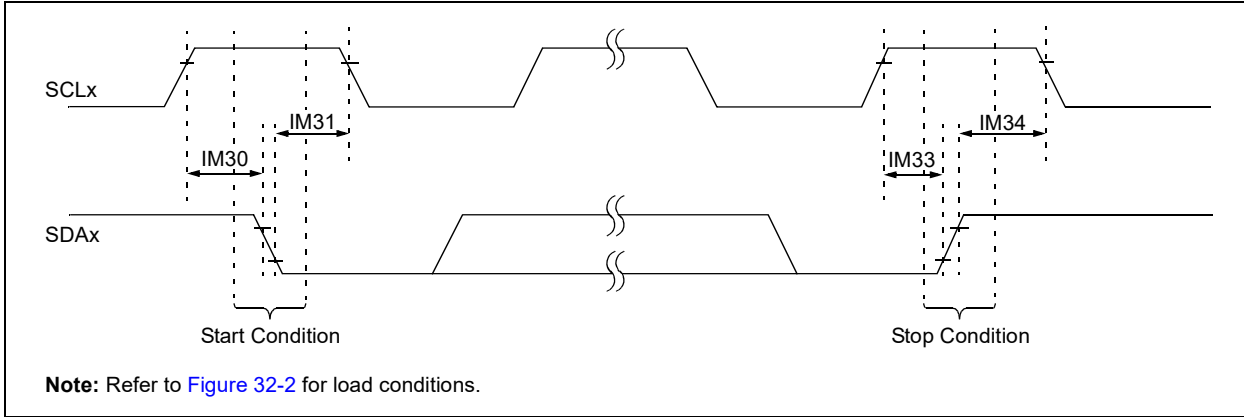
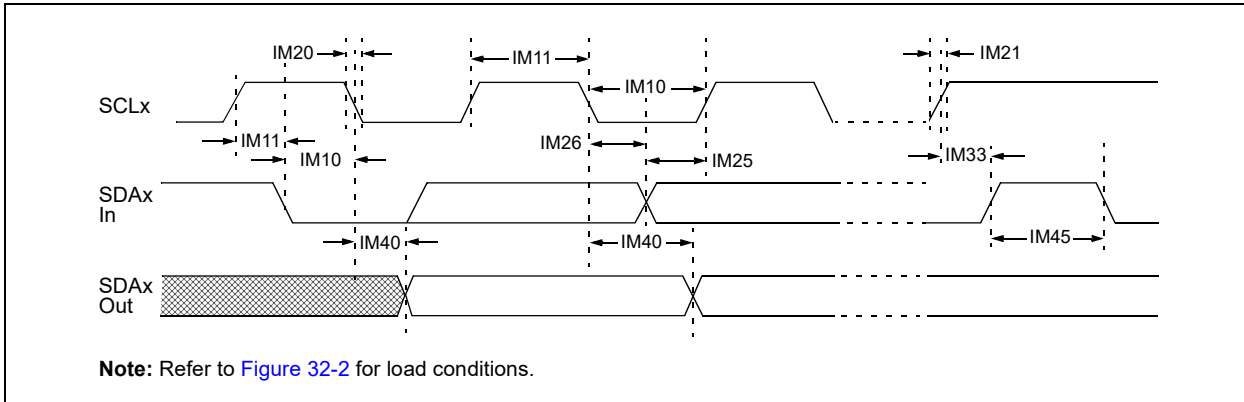

FIGURE 32-16: I2Cx BUS DATA TIMING CHARACTERISTICS (MASTER MODE)



PIC24FJ256GA705 FAMILY

TABLE 32-32: I2Cx BUS DATA TIMING REQUIREMENTS (MASTER MODE)

Operating Conditions (unless otherwise stated): 2.0V < VDD < 3.6V, -40°C ≤ TA ≤ +85°C for Industrial, -40°C ≤ TA ≤ +125°C for Extended							
Param No.	Symbol	Characteristics		Min. ⁽¹⁾	Max.	Units	Conditions
IM10	TLO:SCL	Clock Low Time	100 kHz mode	T _{CY} * (BRG + 2)	—	μs	
			400 kHz mode	T _{CY} * (BRG + 2)	—	μs	
			1 MHz mode	T _{CY} * (BRG + 2)	—	μs	
IM11	THI:SCL	Clock High Time	100 kHz mode	T _{CY} * (BRG + 2)	—	μs	
			400 kHz mode	T _{CY} * (BRG + 2)	—	μs	
			1 MHz mode	T _{CY} * (BRG + 2)	—	μs	
IM20	TF:SCL	SDAx and SCLx Fall Time	100 kHz mode	—	300	ns	
			400 kHz mode	20 + 0.1 C _B	300	ns	
			1 MHz mode	—	100	ns	
IM21	TR:SCL	SDAx and SCLx Rise Time	100 kHz mode	—	1000	ns	
			400 kHz mode	20 + 0.1 C _B	300	ns	
			1 MHz mode	—	300	ns	
IM25	TSU:DAT	Data Input Setup Time	100 kHz mode	250	—	ns	
			400 kHz mode	100	—	ns	
			1 MHz mode	100	—	ns	
IM26	THD:DAT	Data Input Hold Time	100 kHz mode	0	—	μs	
			400 kHz mode	0	0.9	μs	
			1 MHz mode	0	0.3	μs	
IM30	TSU:STA	Start Condition Setup Time	100 kHz mode	T _{CY} * (BRG + 2)	—	μs	Only relevant for Repeated Start condition
			400 kHz mode	T _{CY} * (BRG + 2)	—	μs	
			1 MHz mode	T _{CY} * (BRG + 2)	—	μs	
IM31	THD:STA	Start Condition Hold Time	100 kHz mode	T _{CY} * (BRG + 2)	—	μs	After this period, the first clock pulse is generated
			400 kHz mode	T _{CY} * (BRG + 2)	—	μs	
			1 MHz mode	T _{CY} * (BRG + 2)	—	μs	
IM33	TSU:STO	Stop Condition Setup Time	100 kHz mode	T _{CY} * (BRG + 2)	—	μs	
			400 kHz mode	T _{CY} * (BRG + 2)	—	μs	
			1 MHz mode	T _{CY} * (BRG + 2)	—	μs	
IM34	THD:STO	Stop Condition Hold Time	100 kHz mode	T _{CY} * (BRG + 2)	—	ns	
			400 kHz mode	T _{CY} * (BRG + 2)	—	ns	
			1 MHz mode	T _{CY} * (BRG + 2)	—	ns	
IM40	TAA:SCL	Output Valid from Clock	100 kHz mode	—	3500	ns	
			400 kHz mode	—	1000	ns	
			1 MHz mode	—	350	ns	
IM45	TBF:SDA	Bus Free Time	100 kHz mode	4.7	—	μs	The amount of time the bus must be free before a new transmission can start
			400 kHz mode	1.3	—	μs	
			1 MHz mode	0.5	—	μs	
IM50	CB	Bus Capacitive Loading	100 kHz mode	—	400	pF	
			400 kHz mode	—	400	pF	
			1 MHz mode	—	10	pF	
IM51	TPGD	Pulse Gobbler Delay		52	312	ns	

Note 1: BRG is the value of the I²C Baud Rate Generator.

PIC24FJ256GA705 FAMILY

FIGURE 32-17: I2Cx BUS START/STOP BITS TIMING CHARACTERISTICS (SLAVE MODE)

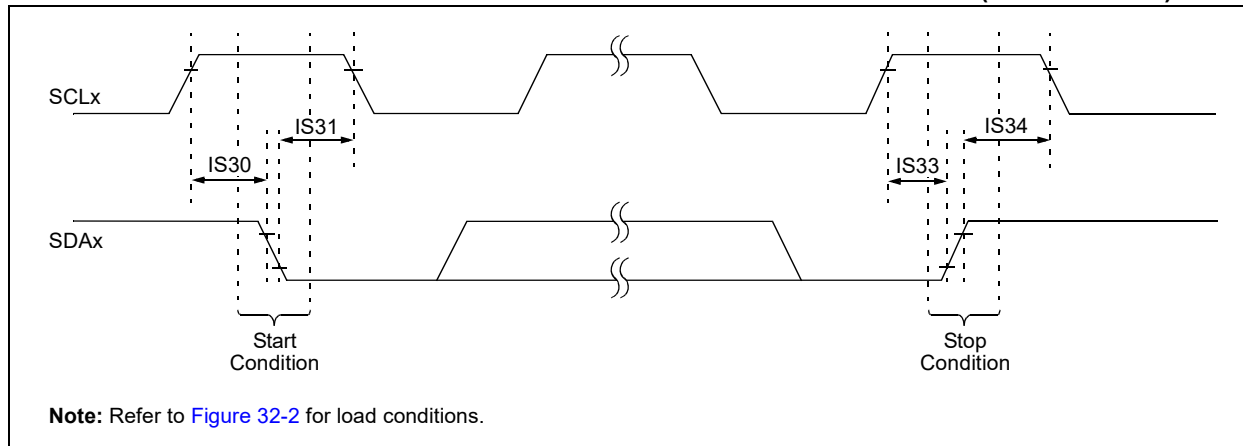
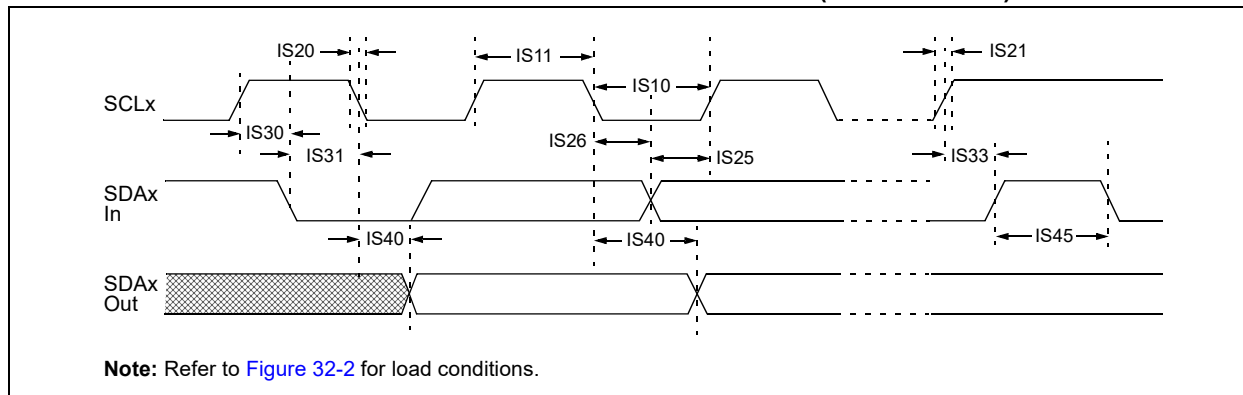

FIGURE 32-18: I2Cx BUS DATA TIMING CHARACTERISTICS (SLAVE MODE)



PIC24FJ256GA705 FAMILY

TABLE 32-33: I2Cx BUS DATA TIMING REQUIREMENTS (SLAVE MODE)

Operating Conditions (unless otherwise stated): 2.0V < VDD < 3.6V, -40°C ≤ TA ≤ +85°C for Industrial, -40°C ≤ TA ≤ +125°C for Extended							
Param No.	Symbol	Characteristics	Min.	Max.	Units	Conditions	
IS10	TLO:SCL	Clock Low Time	100 kHz mode	4.7	—	μs	CPU clock must be a minimum 800 kHz
			400 kHz mode	1.3	—	μs	CPU clock must be a minimum 3.2 MHz
			1 MHz mode	0.5	—	μs	
IS11	THI:SCL	Clock High Time	100 kHz mode	4.0	—	μs	CPU clock must be a minimum 800 kHz
			400 kHz mode	0.6	—	μs	CPU clock must be a minimum 3.2 MHz
			1 MHz mode	0.5	—	μs	
IS20	TF:SCL	SDAx and SCLx Fall Time	100 kHz mode	—	300	ns	
			400 kHz mode	20 + 0.1 CB	300	ns	
			1 MHz mode	—	100	ns	
IS21	TR:SCL	SDAx and SCLx Rise Time	100 kHz mode	—	1000	ns	
			400 kHz mode	20 + 0.1 CB	300	ns	
			1 MHz mode	—	300	ns	
IS25	TSU:DAT	Data Input Setup Time	100 kHz mode	250	—	ns	
			400 kHz mode	100	—	ns	
			1 MHz mode	100	—	ns	
IS26	THD:DAT	Data Input Hold Time	100 kHz mode	0	—	ns	
			400 kHz mode	0	0.9	μs	
			1 MHz mode	0	0.3	μs	
IS30	TSU:STA	Start Condition Setup Time	100 kHz mode	4700	—	ns	Only relevant for Repeated Start condition
			400 kHz mode	600	—	ns	
			1 MHz mode	250	—	ns	
IS31	THD:STA	Start Condition Hold Time	100 kHz mode	4000	—	ns	After this period, the first clock pulse is generated
			400 kHz mode	600	—	ns	
			1 MHz mode	250	—	ns	
IS33	TSU:STO	Stop Condition Setup Time	100 kHz mode	4000	—	ns	
			400 kHz mode	600	—	ns	
			1 MHz mode	600	—	ns	
IS34	THD:STO	Stop Condition Hold Time	100 kHz mode	4000	—	ns	
			400 kHz mode	600	—	ns	
			1 MHz mode	250	—	ns	
IS40	TAA:SCL	Output Valid from Clock	100 kHz mode	0	3500	ns	
			400 kHz mode	0	1000	ns	
			1 MHz mode	0	350	ns	
IS45	TBF:SDA	Bus Free Time	100 kHz mode	4.7	—	μs	The amount of time the bus must be free before a new transmission can start
			400 kHz mode	1.3	—	μs	
			1 MHz mode	0.5	—	μs	
IS50	CB	Bus Capacitive Loading	100 kHz mode	—	400	pF	
			400 kHz mode	—	400	pF	
			1 MHz mode	—	10	pF	

PIC24FJ256GA705 FAMILY

TABLE 32-34: A/D MODULE SPECIFICATIONS

AC CHARACTERISTICS			Standard Operating Conditions: 2.0V to 3.6V (unless otherwise stated)				
			Operating temperature		-40°C ≤ TA ≤ +85°C for Industrial -40°C ≤ TA ≤ +125°C for Extended		
Param No.	Symbol	Characteristic	Min.	Typ	Max.	Units	Conditions
Device Supply							
AD01	AVDD	Module VDD Supply	Greater of: VDD - 0.3 or 2.2	—	Lesser of: VDD + 0.3 or 3.6	V	
AD02	AVSS	Module VSS Supply	VSS - 0.3	—	VSS + 0.3	V	
Reference Inputs							
AD05	VREFH	Reference Voltage High	AVSS + 1.7	—	AVDD	V	
AD06	VREFL	Reference Voltage Low	AVSS	—	AVDD - 1.7	V	
AD07	VREF	Absolute Reference Voltage	AVSS - 0.3	—	AVDD + 0.3	V	
Analog Inputs							
AD10	VINH-VINL	Full-Scale Input Span	VREFL	—	VREFH	V	Note 2
AD11	VIN	Absolute Input Voltage	AVSS - 0.3	—	AVDD + 0.3	V	
AD12	VINL	Absolute VINL Input Voltage	AVSS - 0.3	—	AVDD/3	V	
AD13		Leakage Current	—	±1.0	±610	nA	VINL = AVSS = VREFL = 0V, AVDD = VREFH = 3V, Source Impedance = 2.5 kΩ
AD17	RIN	Recommended Impedance of Analog Voltage Source	—	—	2.5k	Ω	10-bit
A/D Accuracy							
AD20B	Nr	Resolution	—	12	—	bits	
AD21B	INL	Integral Nonlinearity	—	±1	< ±2	LSb	VINL = AVSS = VREFL = 0V, AVDD = VREFH = 3V
AD22B	DNL	Differential Nonlinearity	—	—	< ±1	LSb	VINL = AVSS = VREFL = 0V, AVDD = VREFH = 3V
AD23B	GERR	Gain Error	—	±1	±4	LSb	VINL = AVSS = VREFL = 0V, AVDD = VREFH = 3V
AD24B	E _{OFF}	Offset Error	—	±1	±2	LSb	VINL = AVSS = VREFL = 0V, AVDD = VREFH = 3V
AD25B		Monotonicity ⁽¹⁾	—	—	—	—	Guaranteed

Note 1: The A/D conversion result never decreases with an increase in the input voltage.

2: Measurements are taken with the external VREF+ and VREF- used as the A/D voltage reference.

PIC24FJ256GA705 FAMILY

TABLE 32-35: A/D CONVERSION TIMING REQUIREMENTS⁽¹⁾

AC CHARACTERISTICS			Standard Operating Conditions: 2.0V to 3.6V (unless otherwise stated)				
			Operating temperature		-40°C ≤ TA ≤ +85°C for Industrial -40°C ≤ TA ≤ +125°C for Extended		
Param No.	Symbol	Characteristic	Min.	Typ	Max.	Units	Conditions
Clock Parameters							
AD50	TAD	A/D Clock Period	278	—	—	ns	
AD51	tRC	A/D Internal RC Oscillator Period	—	250	—	ns	
Conversion Rate							
AD55	tCONV	SAR Conversion Time, 12-Bit Mode	—	14	—	TAD	
AD55A		SAR Conversion Time, 10-Bit Mode is Typical 12 TAD	—	12	—	TAD	
AD56	FCNV	Throughput Rate	—	—	200	ksps	AVDD > 2.7V ⁽²⁾
AD57	tSAMP	Sample Time	—	1	—	TAD	
Clock Synchronization							
AD61	tPSS	Sample Start Delay from Setting Sample bit (SAMP)	1.5	—	2.5	TAD	

Note 1: Because the sample caps will eventually lose charge, clock rates below 10 kHz can affect linearity performance, especially at elevated temperatures.

2: Throughput rate is based on AD55 + AD57 + AD61 and the period of TAD.

PIC24FJ256GA705 FAMILY

NOTES:

33.0 PACKAGING INFORMATION

33.1 Package Marking Information

28-Lead QFN (6x6 mm)

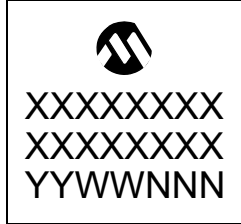

Example

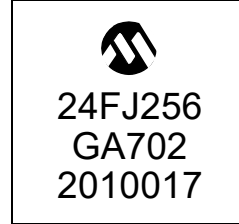

28-Lead UQFN (4x4x0.5 mm)

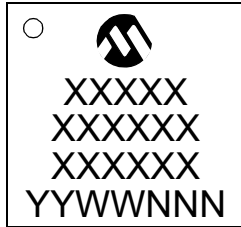

Example



28-Lead SOIC (7.50 mm)



Example

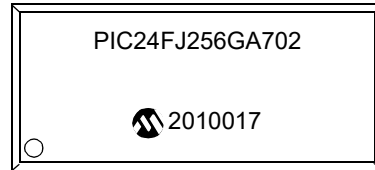

28-Lead SSOP (5.30 mm)

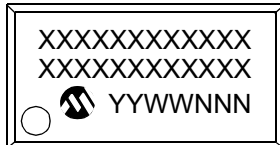

Example

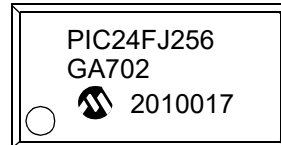

Legend:	XX...X	Customer-specific information
	Y	Year code (last digit of calendar year)
	YY	Year code (last 2 digits of calendar year)
	WW	Week code (week of January 1 is week '01')
	NNN	Alphanumeric traceability code
Note:	In the event the full Microchip part number cannot be marked on one line, it will be carried over to the next line, thus limiting the number of available characters for customer-specific information.	

PIC24FJ256GA705 FAMILY

33.1 Package Marking Information (Continued)

28-Lead SPDIP (300 mil)

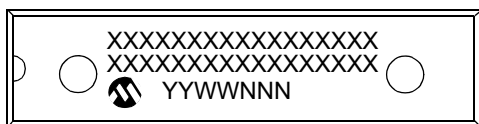

Example

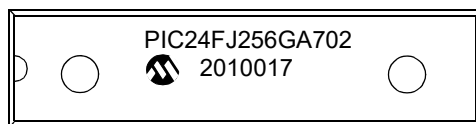

44-Lead TQFP (10x10x1 mm)

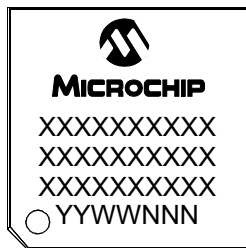

Example

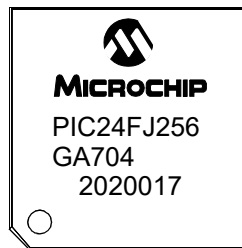

48-Lead UQFN (6x6 mm)



Example



48-Lead TQFP (7x7x1.0 mm)

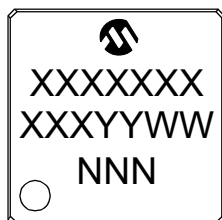

Example



PIC24FJ256GA705 FAMILY

33.2 Package Details

The following sections give the technical details of the packages.

28-Lead Plastic Quad Flat, No Lead Package (ML) - 6x6 mm Body [QFN] With 0.55 mm Terminal Length

Note: For the most current package drawings, please see the Microchip Packaging Specification located at <http://www.microchip.com/packaging>

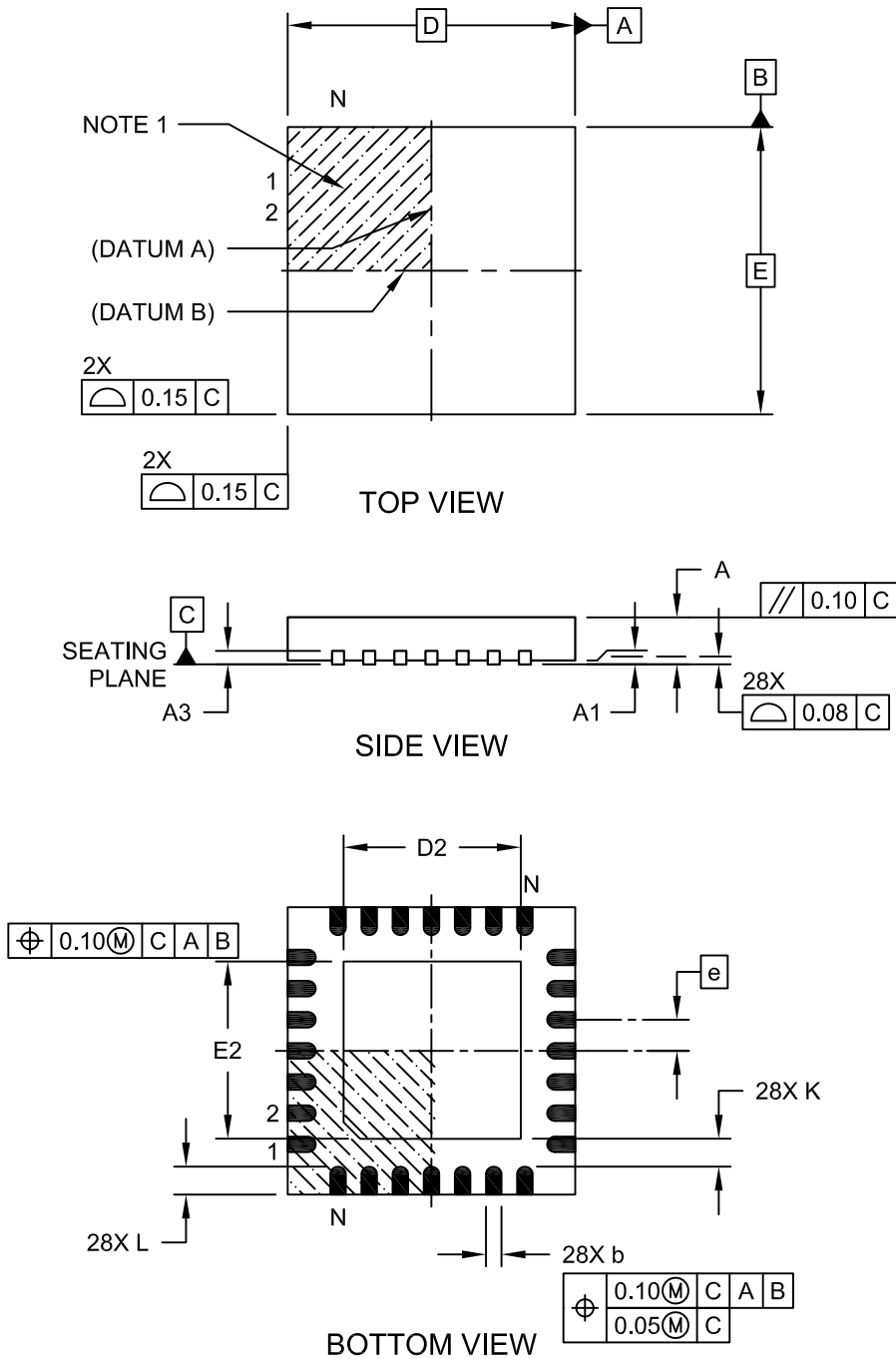

Microchip Technology Drawing C04-105C Sheet 1 of 2

PIC24FJ256GA705 FAMILY

28-Lead Plastic Quad Flat, No Lead Package (ML) - 6x6 mm Body [QFN] With 0.55 mm Terminal Length

Note: For the most current package drawings, please see the Microchip Packaging Specification located at <http://www.microchip.com/packaging>

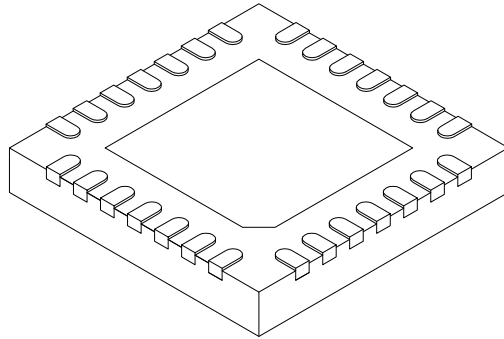

Dimension	Units Limits	MILLIMETERS		
		MIN	NOM	MAX
Number of Pins	N	28		
Pitch	e	0.65 BSC		
Overall Height	A	0.80	0.90	1.00
Standoff	A1	0.00	0.02	0.05
Terminal Thickness	A3	0.20 REF		
Overall Width	E	6.00 BSC		
Exposed Pad Width	E2	3.65	3.70	4.20
Overall Length	D	6.00 BSC		
Exposed Pad Length	D2	3.65	3.70	4.20
Terminal Width	b	0.23	0.30	0.35
Terminal Length	L	0.50	0.55	0.70
Terminal-to-Exposed Pad	K	0.20	-	-

Notes:

1. Pin 1 visual index feature may vary, but must be located within the hatched area.
2. Package is saw singulated
3. Dimensioning and tolerancing per ASME Y14.5M.
BSC: Basic Dimension. Theoretically exact value shown without tolerances.
REF: Reference Dimension, usually without tolerance, for information purposes only.

Microchip Technology Drawing C04-105C Sheet 2 of 2

PIC24FJ256GA705 FAMILY

28-Lead Plastic Quad Flat, No Lead Package (ML) – 6x6 mm Body [QFN] with 0.55 mm Contact Length

Note: For the most current package drawings, please see the Microchip Packaging Specification located at <http://www.microchip.com/packaging>

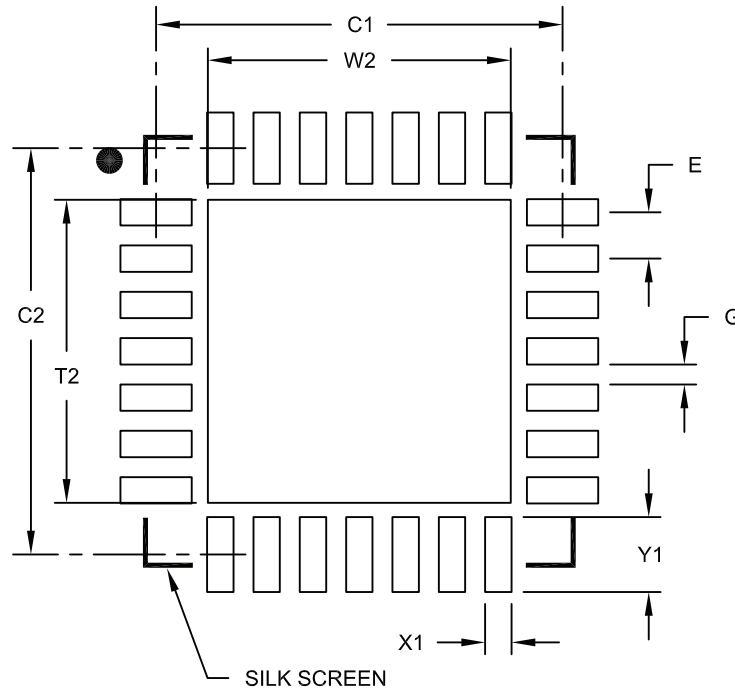

RECOMMENDED LAND PATTERN

Dimension Limits	Units	MILLIMETERS		
		MIN	NOM	MAX
Contact Pitch	E	0.65 BSC		
Optional Center Pad Width	W2			4.25
Optional Center Pad Length	T2			4.25
Contact Pad Spacing	C1		5.70	
Contact Pad Spacing	C2		5.70	
Contact Pad Width (X28)	X1			0.37
Contact Pad Length (X28)	Y1			1.00
Distance Between Pads	G	0.20		

Notes:

1. Dimensioning and tolerancing per ASME Y14.5M

BSC: Basic Dimension. Theoretically exact value shown without tolerances.

Microchip Technology Drawing No. C04-2105A

PIC24FJ256GA705 FAMILY

28-Lead Plastic Ultra Thin Quad Flat, No Lead Package (MV) – 4x4x0.5 mm Body [UQFN]

Note: For the most current package drawings, please see the Microchip Packaging Specification located at <http://www.microchip.com/packaging>

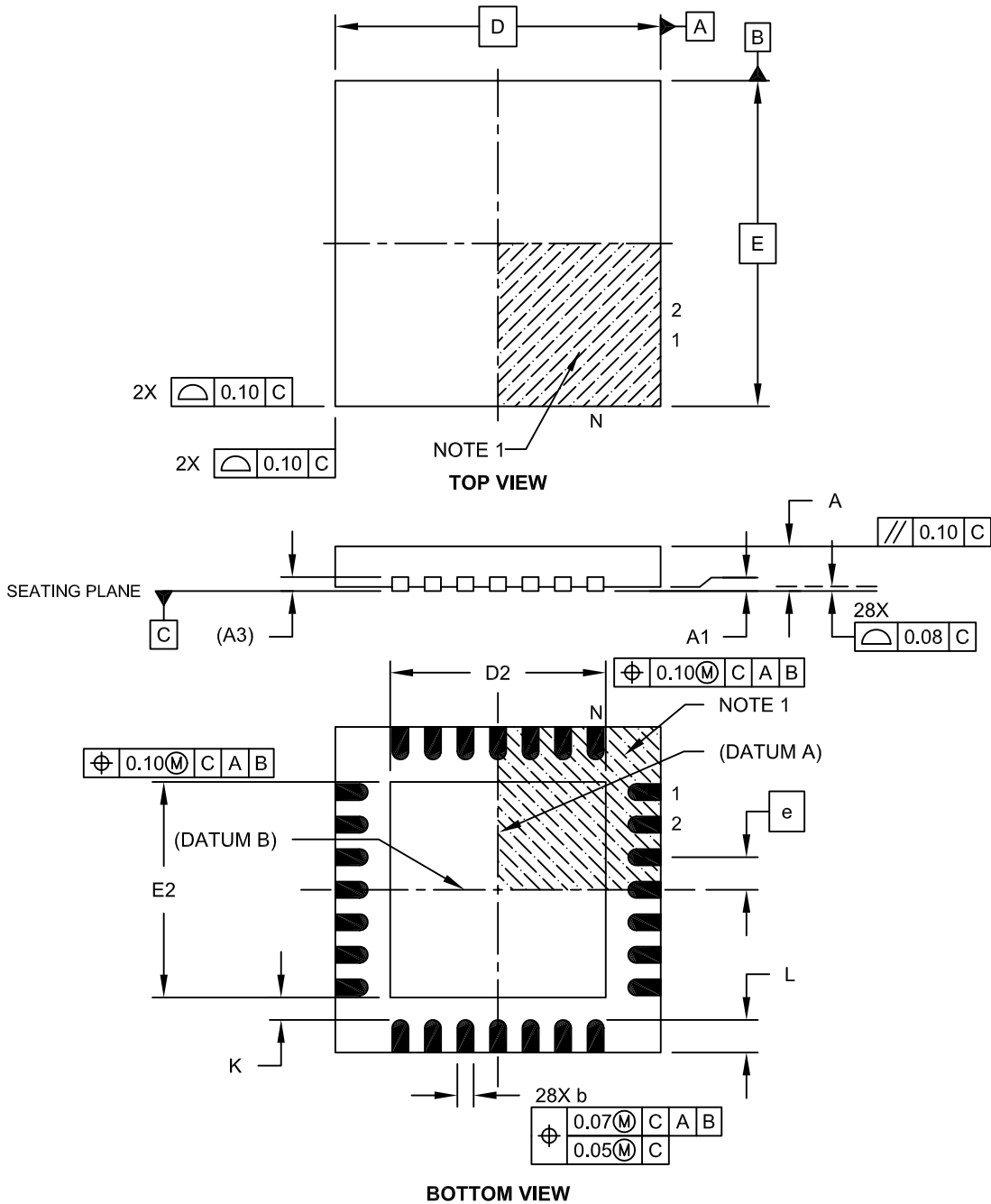

Microchip Technology Drawing C04-152A Sheet 1 of 2

PIC24FJ256GA705 FAMILY

28-Lead Plastic Ultra Thin Quad Flat, No Lead Package (MV) – 4x4x0.5 mm Body [UQFN]

Note: For the most current package drawings, please see the Microchip Packaging Specification located at <http://www.microchip.com/packaging>

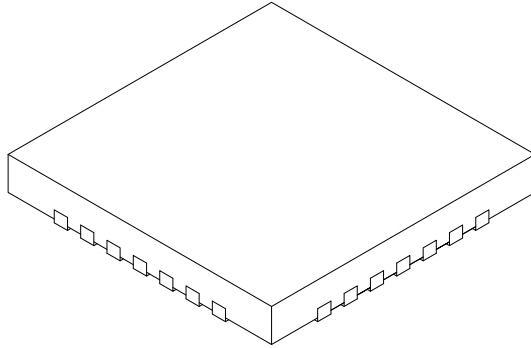

Units		MILLIMETERS		
Dimension Limits		MIN	NOM	MAX
Number of Pins	N	28		
Pitch	e	0.40 BSC		
Overall Height	A	0.45	0.50	0.55
Standoff	A1	0.00	0.02	0.05
Contact Thickness	A3	0.127 REF		
Overall Width	E	4.00 BSC		
Exposed Pad Width	E2	2.55	2.65	2.75
Overall Length	D	4.00 BSC		
Exposed Pad Length	D2	2.55	2.65	2.75
Contact Width	b	0.15	0.20	0.25
Contact Length	L	0.30	0.40	0.50
Contact-to-Exposed Pad	K	0.20	-	-

Notes:

1. Pin 1 visual index feature may vary, but must be located within the hatched area.
2. Package is saw singulated.
3. Dimensioning and tolerancing per ASME Y14.5M.
BSC: Basic Dimension. Theoretically exact value shown without tolerances.
REF: Reference Dimension, usually without tolerance, for information purposes only.

Microchip Technology Drawing C04-152A Sheet 2 of 2

PIC24FJ256GA705 FAMILY

28-Lead Ultra Thin Plastic Quad Flat, No Lead Package (MV) - 4x4 mm Body [UQFN]
With 0.40 mm Contact Length

Note: For the most current package drawings, please see the Microchip Packaging Specification located at <http://www.microchip.com/packaging>

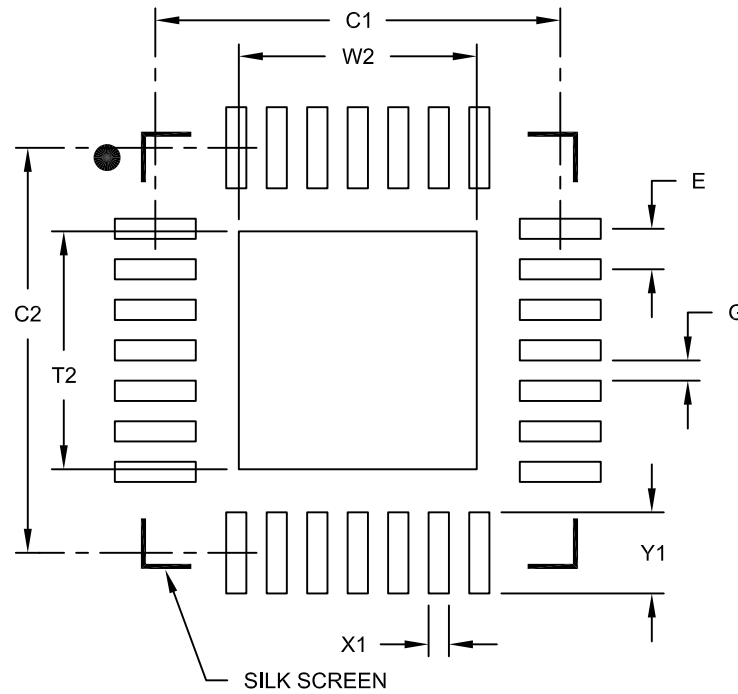

RECOMMENDED LAND PATTERN

Dimension	Units	MILLIMETERS		
		MIN	NOM	MAX
Contact Pitch	E	0,40 BSC		
Optional Center Pad Width	W2			2,35
Optional Center Pad Length	T2			2,35
Contact Pad Spacing	C1		4,00	
Contact Pad Spacing	C2		4,00	
Contact Pad Width (X28)	X1			0,20
Contact Pad Length (X28)	Y1			0,80
Distance Between Pads	G	0,20		

Notes:

1. Dimensioning and tolerancing per ASME Y14.5M

BSC: Basic Dimension. Theoretically exact value shown without tolerances.

Microchip Technology Drawing No. C04-2152A

PIC24FJ256GA705 FAMILY

28-Lead Plastic Small Outline (SO) - Wide, 7.50 mm Body [SOIC]

Note: For the most current package drawings, please see the Microchip Packaging Specification located at <http://www.microchip.com/packaging>

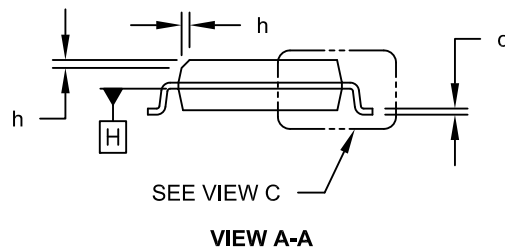
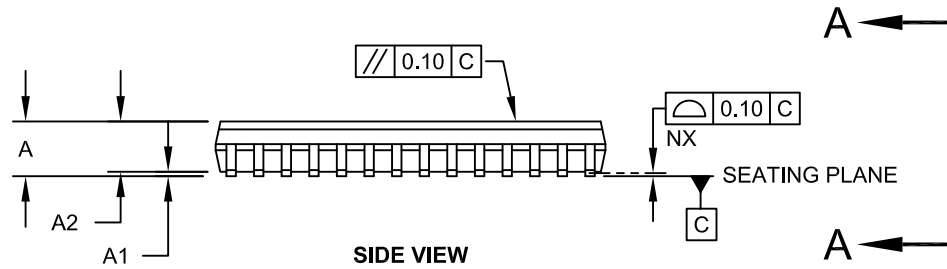
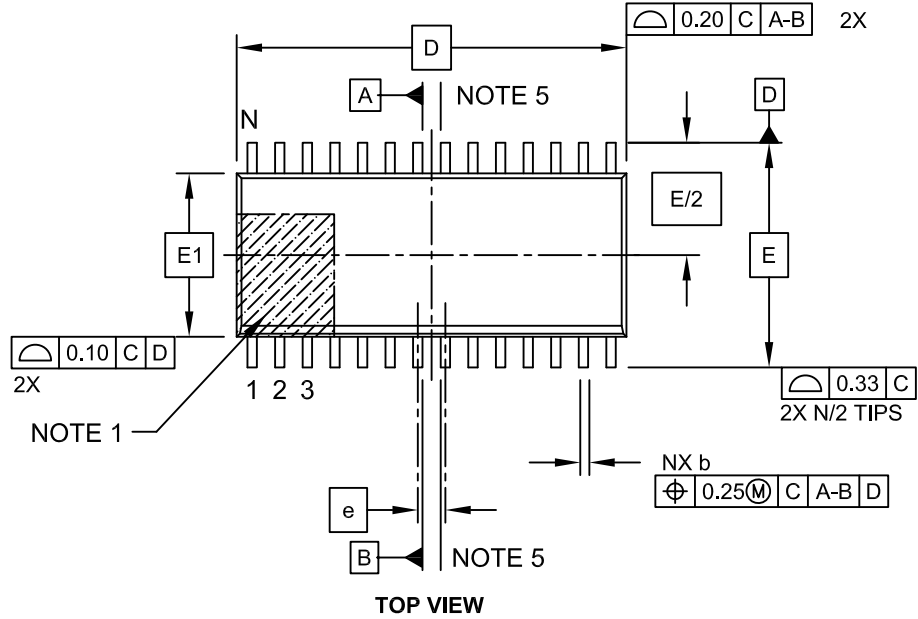

Microchip Technology Drawing C04-052C Sheet 1 of 2

PIC24FJ256GA705 FAMILY

28-Lead Plastic Small Outline (SO) - Wide, 7.50 mm Body [SOIC]

Note: For the most current package drawings, please see the Microchip Packaging Specification located at <http://www.microchip.com/packaging>

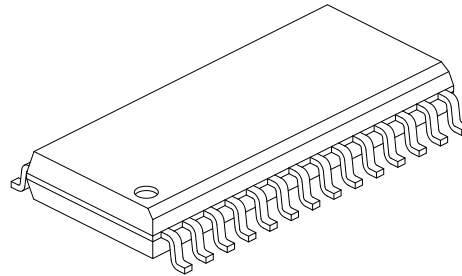
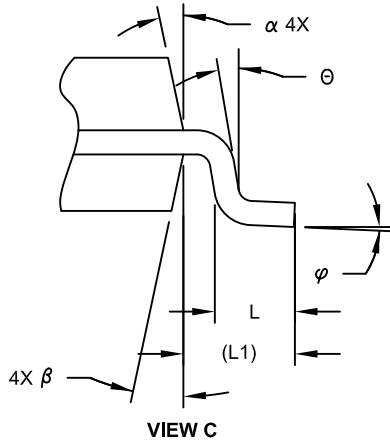

Dimension Limits	Units	MILLIMETERS		
		MIN	NOM	MAX
Number of Pins	N	28		
Pitch	e	1.27 BSC		
Overall Height	A	-	-	2.65
Molded Package Thickness	A2	2.05	-	-
Standoff §	A1	0.10	-	0.30
Overall Width	E	10.30 BSC		
Molded Package Width	E1	7.50 BSC		
Overall Length	D	17.90 BSC		
Chamfer (Optional)	h	0.25	-	0.75
Foot Length	L	0.40	-	1.27
Footprint	L1	1.40 REF		
Lead Angle	θ	0°	-	-
Foot Angle	φ	0°	-	8°
Lead Thickness	c	0.18	-	0.33
Lead Width	b	0.31	-	0.51
Mold Draft Angle Top	α	5°	-	15°
Mold Draft Angle Bottom	β	5°	-	15°

Notes:

- Pin 1 visual index feature may vary, but must be located within the hatched area.
- § Significant Characteristic
- Dimension D does not include mold flash, protrusions or gate burrs, which shall not exceed 0.15 mm per end. Dimension E1 does not include interlead flash or protrusion, which shall not exceed 0.25 mm per side.
- Dimensioning and tolerancing per ASME Y14.5M
 BSC: Basic Dimension. Theoretically exact value shown without tolerances.
 REF: Reference Dimension, usually without tolerance, for information purposes only.
- Datums A & B to be determined at Datum H.

Microchip Technology Drawing C04-052C Sheet 2 of 2

PIC24FJ256GA705 FAMILY

28-Lead Plastic Small Outline (SO) - Wide, 7.50 mm Body [SOIC]

Note: For the most current package drawings, please see the Microchip Packaging Specification located at <http://www.microchip.com/packaging>

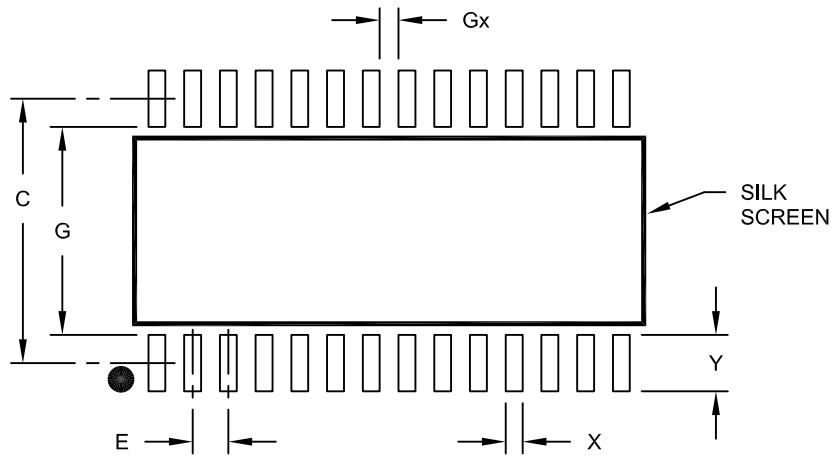

RECOMMENDED LAND PATTERN

Dimension Limits	Units	MILLIMETERS		
		MIN	NOM	MAX
Contact Pitch	E	1.27 BSC		
Contact Pad Spacing	C	9.40		
Contact Pad Width (X28)	X			0.60
Contact Pad Length (X28)	Y			2.00
Distance Between Pads	Gx	0.67		
Distance Between Pads	G	7.40		

Notes:

1. Dimensioning and tolerancing per ASME Y14.5M

BSC: Basic Dimension. Theoretically exact value shown without tolerances.

Microchip Technology Drawing No. C04-2052A

PIC24FJ256GA705 FAMILY

28-Lead Plastic Shrink Small Outline (SS) - 5.30 mm Body [SSOP]

Note: For the most current package drawings, please see the Microchip Packaging Specification located at <http://www.microchip.com/packaging>

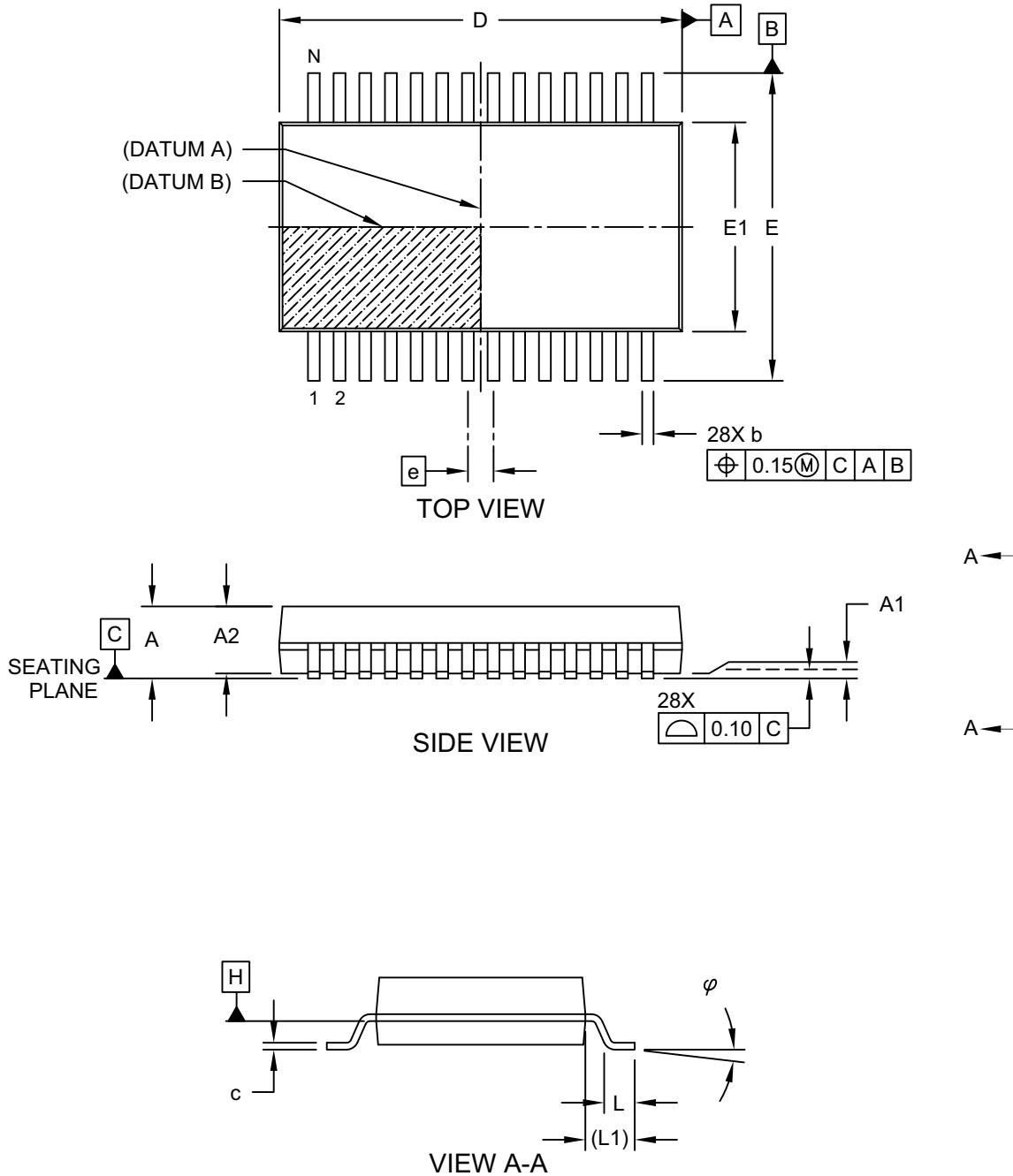

Microchip Technology Drawing C04-073 Rev C Sheet 1 of 2

PIC24FJ256GA705 FAMILY

28-Lead Plastic Shrink Small Outline (SS) - 5.30 mm Body [SSOP]

Note: For the most current package drawings, please see the Microchip Packaging Specification located at <http://www.microchip.com/packaging>

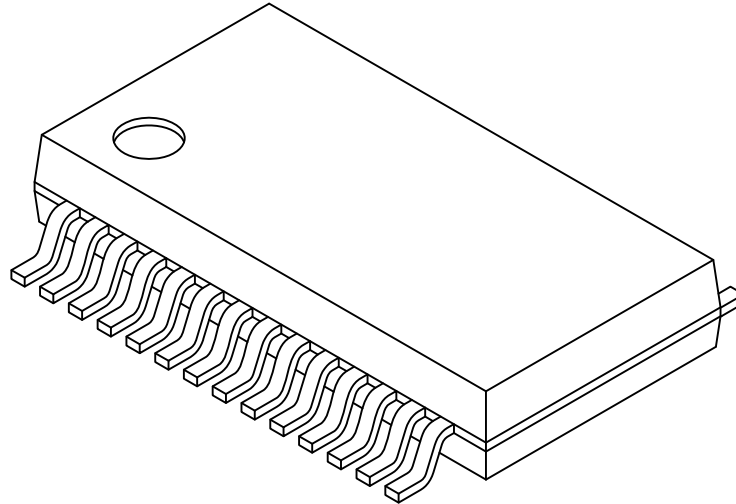

Units		MILLIMETERS		
Dimension Limits		MIN	NOM	MAX
Number of Pins	N	28		
Pitch	e	0.65 BSC		
Overall Height	A	-	-	2.00
Molded Package Thickness	A2	1.65	1.75	1.85
Standoff	A1	0.05	-	-
Overall Width	E	7.40	7.80	8.20
Molded Package Width	E1	5.00	5.30	5.60
Overall Length	D	9.90	10.20	10.50
Foot Length	L	0.55	0.75	0.95
Footprint	L1	1.25 REF		
Lead Thickness	c	0.09	-	0.25
Foot Angle	φ	0°	4°	8°
Lead Width	b	0.22	-	0.38

Notes:

1. Pin 1 visual index feature may vary, but must be located within the hatched area.
2. Dimensions D and E1 do not include mold flash or protrusions. Mold flash or protrusions shall not exceed 0.20mm per side.
3. Dimensioning and tolerancing per ASME Y14.5M

BSC: Basic Dimension. Theoretically exact value shown without tolerances.

REF: Reference Dimension, usually without tolerance, for information purposes only.

Microchip Technology Drawing C04-073 Rev C Sheet 2 of 2

PIC24FJ256GA705 FAMILY

28-Lead Plastic Shrink Small Outline (SS) - 5.30 mm Body [SSOP]

Note: For the most current package drawings, please see the Microchip Packaging Specification located at <http://www.microchip.com/packaging>

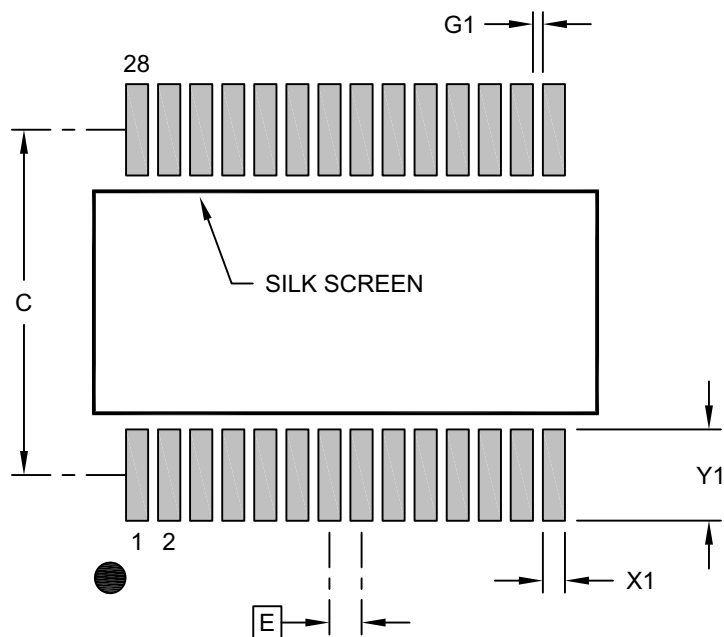

RECOMMENDED LAND PATTERN

Dimension Limits	Units	MILLIMETERS		
		MIN	NOM	MAX
Contact Pitch	E	0.65 BSC		
Contact Pad Spacing	C		7.00	
Contact Pad Width (X28)	X1			0.45
Contact Pad Length (X28)	Y1			1.85
Contact Pad to Center Pad (X26)	G1	0.20		

Notes:

1. Dimensioning and tolerancing per ASME Y14.5M
BSC: Basic Dimension. Theoretically exact value shown without tolerances.
2. For best soldering results, thermal vias, if used, should be filled or tented to avoid solder loss during reflow process

Microchip Technology Drawing C04-2073 Rev B

PIC24FJ256GA705 FAMILY

28-Lead Skinny Plastic Dual In-Line (SP) – 300 mil Body [SPDIP]

Note: For the most current package drawings, please see the Microchip Packaging Specification located at <http://www.microchip.com/packaging>

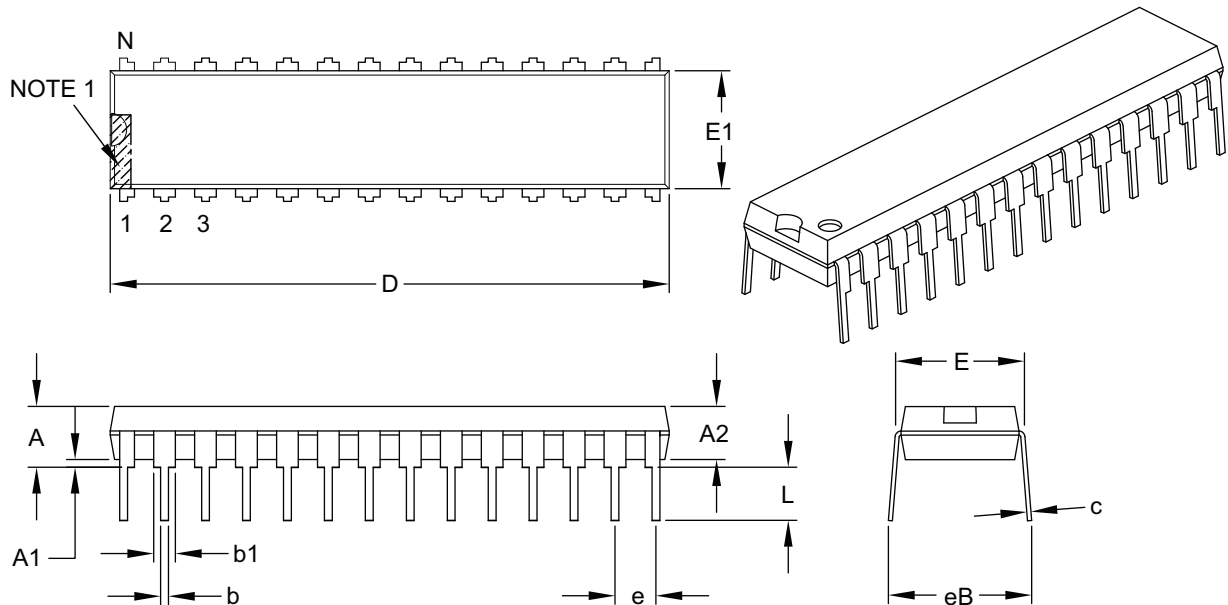

Dimension Limits	Units	INCHES		
		MIN	NOM	MAX
Number of Pins	N	28		
Pitch	e	.100 BSC		
Top to Seating Plane	A	–	–	.200
Molded Package Thickness	A2	.120	.135	.150
Base to Seating Plane	A1	.015	–	–
Shoulder to Shoulder Width	E	.290	.310	.335
Molded Package Width	E1	.240	.285	.295
Overall Length	D	1.345	1.365	1.400
Tip to Seating Plane	L	.110	.130	.150
Lead Thickness	c	.008	.010	.015
Upper Lead Width	b1	.040	.050	.070
Lower Lead Width	b	.014	.018	.022
Overall Row Spacing §	eB	–	–	.430

Notes:

- Pin 1 visual index feature may vary, but must be located within the hatched area.
- § Significant Characteristic.
- Dimensions D and E1 do not include mold flash or protrusions. Mold flash or protrusions shall not exceed .010" per side.
- Dimensioning and tolerancing per ASME Y14.5M.

BSC: Basic Dimension. Theoretically exact value shown without tolerances.

Microchip Technology Drawing C04-070B

PIC24FJ256GA705 FAMILY

44-Lead Plastic Thin Quad Flatpack (PT) - 10x10x1.0 mm Body [TQFP]

Note: For the most current package drawings, please see the Microchip Packaging Specification located at <http://www.microchip.com/packaging>

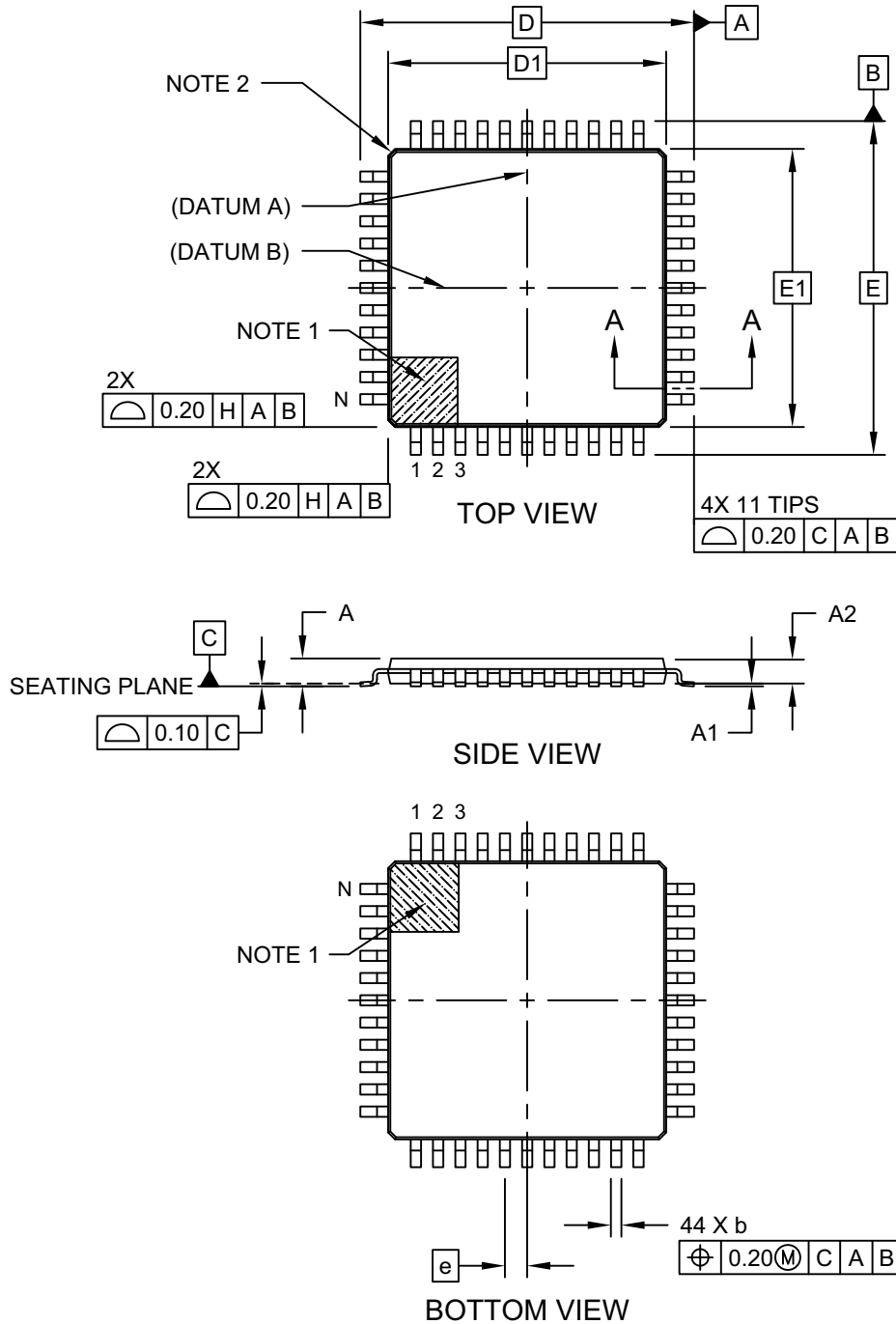

Microchip Technology Drawing C04-076C Sheet 1 of 2

PIC24FJ256GA705 FAMILY

44-Lead Plastic Thin Quad Flatpack (PT) - 10x10x1.0 mm Body [TQFP]

Note: For the most current package drawings, please see the Microchip Packaging Specification located at <http://www.microchip.com/packaging>

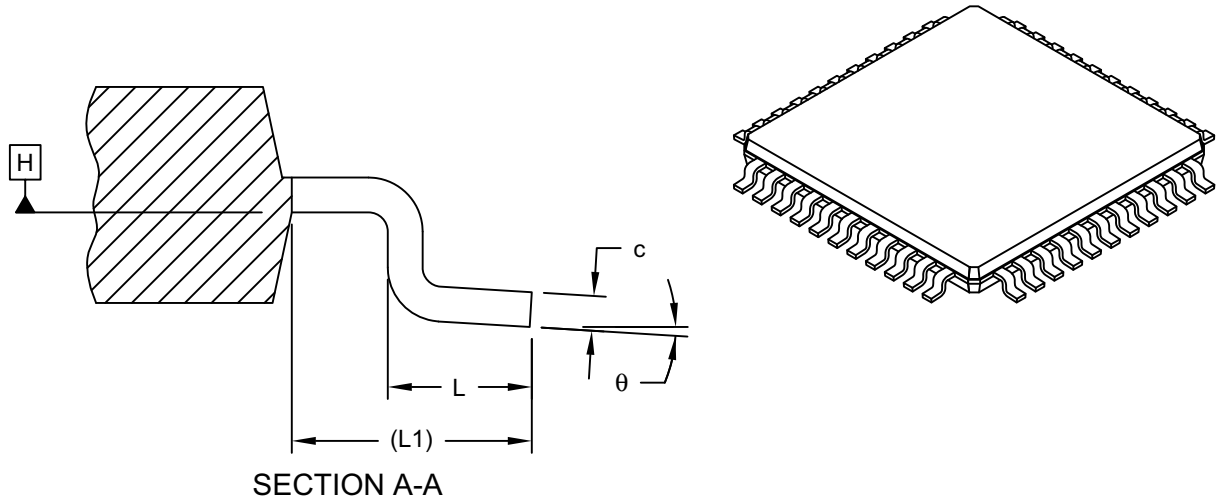

		Units	MILLIMETERS		
Dimension Limits			MIN	NOM	MAX
Number of Leads	N		44		
Lead Pitch	e		0.80 BSC		
Overall Height	A		-	-	1.20
Standoff	A1		0.05	-	0.15
Molded Package Thickness	A2		0.95	1.00	1.05
Overall Width	E		12.00 BSC		
Molded Package Width	E1		10.00 BSC		
Overall Length	D		12.00 BSC		
Molded Package Length	D1		10.00 BSC		
Lead Width	b		0.30	0.37	0.45
Lead Thickness	c		0.09	-	0.20
Lead Length	L		0.45	0.60	0.75
Footprint	L1		1.00 REF		
Foot Angle	θ		0°	3.5°	7°

Notes:

1. Pin 1 visual index feature may vary, but must be located within the hatched area.
2. Exact shape of each corner is optional.
3. Dimensioning and tolerancing per ASME Y14.5M

BSC: Basic Dimension. Theoretically exact value shown without tolerances.

REF: Reference Dimension, usually without tolerance, for information purposes only.

Microchip Technology Drawing C04-076C Sheet 2 of 2

PIC24FJ256GA705 FAMILY

44-Lead Plastic Thin Quad Flatpack (PT) - 10X10X1 mm Body, 2.00 mm Footprint [TQFP]

Note: For the most current package drawings, please see the Microchip Packaging Specification located at <http://www.microchip.com/packaging>

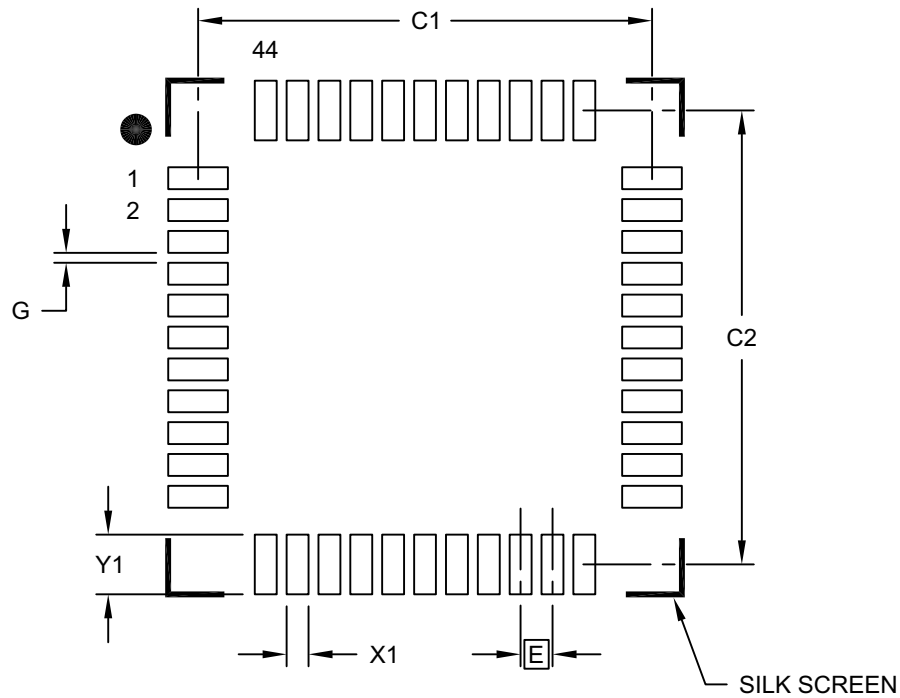

RECOMMENDED LAND PATTERN

Dimension Limits	Units	MILLIMETERS		
		MIN	NOM	MAX
Contact Pitch	E	0.80 BSC		
Contact Pad Spacing	C1		11.40	
Contact Pad Spacing	C2		11.40	
Contact Pad Width (X44)	X1			0.55
Contact Pad Length (X44)	Y1			1.50
Distance Between Pads	G	0.25		

Notes:

1. Dimensioning and tolerancing per ASME Y14.5M

BSC: Basic Dimension. Theoretically exact value shown without tolerances.

Microchip Technology Drawing No. C04-2076B

PIC24FJ256GA705 FAMILY

48-Lead Ultra Thin Plastic Quad Flat, No Lead Package (M4) - 6x6 mm Body [UQFN] With Corner Anchors and 4.6x4.6 mm Exposed Pad

Note: For the most current package drawings, please see the Microchip Packaging Specification located at <http://www.microchip.com/packaging>

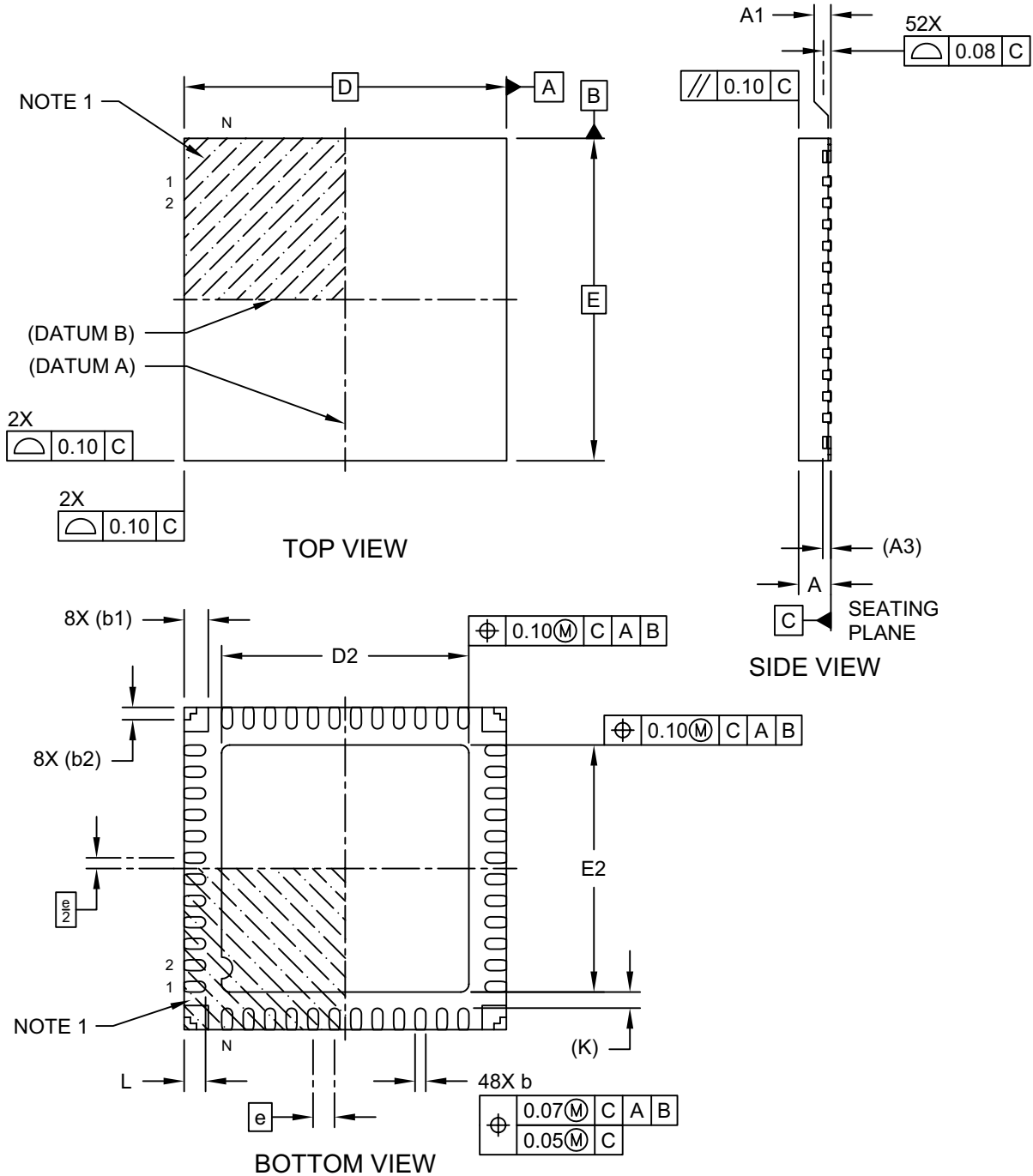

Microchip Technology Drawing C04-442A-M4 Sheet 1 of 2

PIC24FJ256GA705 FAMILY

48-Lead Ultra Thin Plastic Quad Flat, No Lead Package (M4) - 6x6 mm Body [UQFN] With Corner Anchors and 4.6x4.6 mm Exposed Pad

Note: For the most current package drawings, please see the Microchip Packaging Specification located at <http://www.microchip.com/packaging>

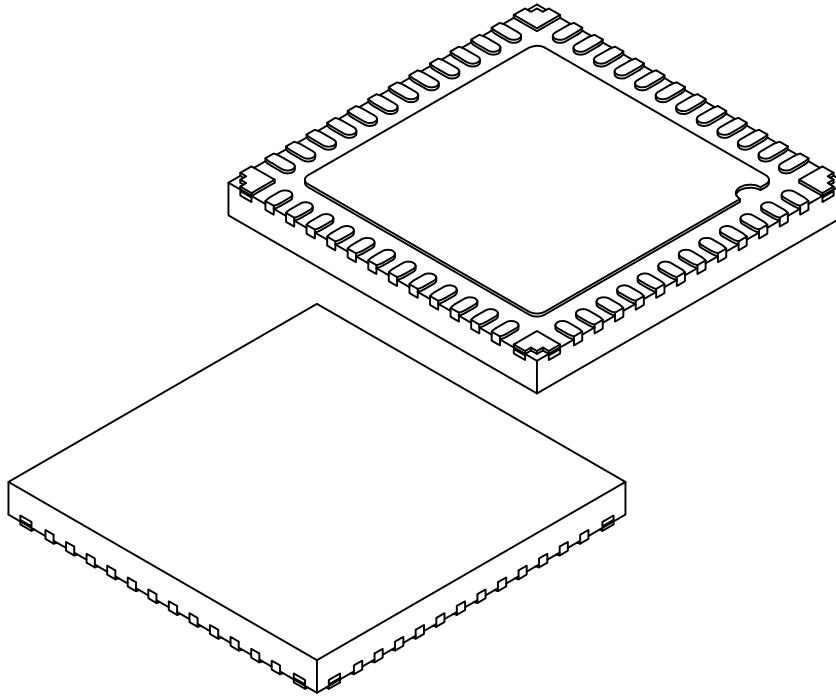

Dimension Limits	Units	MILLIMETERS		
		MIN	NOM	MAX
Number of Terminals	N	48		
Pitch	e	0.40 BSC		
Overall Height	A	0.50	0.55	0.60
Standoff	A1	0.00	0.02	0.05
Terminal Thickness	A3	0.15 REF		
Overall Length	D	6.00 BSC		
Exposed Pad Length	D2	4.50	4.60	4.70
Overall Width	E	6.00 BSC		
Exposed Pad Width	E2	4.50	4.60	4.70
Terminal Width	b	0.15	0.20	0.25
Corner Anchor Pad	b1	0.45 REF		
Corner Anchor Pad, Metal-free Zone	b2	0.23 REF		
Terminal Length	L	0.35	0.40	0.45
Terminal-to-Exposed-Pad	K	0.30 REF		

Notes:

1. Pin 1 visual index feature may vary, but must be located within the hatched area.
2. Package is saw singulated
3. Dimensioning and tolerancing per ASME Y14.5M

BSC: Basic Dimension. Theoretically exact value shown without tolerances.

REF: Reference Dimension, usually without tolerance, for information purposes only.

Microchip Technology Drawing C04-442A-M4 Sheet 2 of 2

PIC24FJ256GA705 FAMILY

48-Lead Ultra Thin Plastic Quad Flat, No Lead Package (M4) - 6x6 mm Body [UQFN] With Corner Anchors and 4.6x4.6 mm Exposed Pad

Note: For the most current package drawings, please see the Microchip Packaging Specification located at <http://www.microchip.com/packaging>

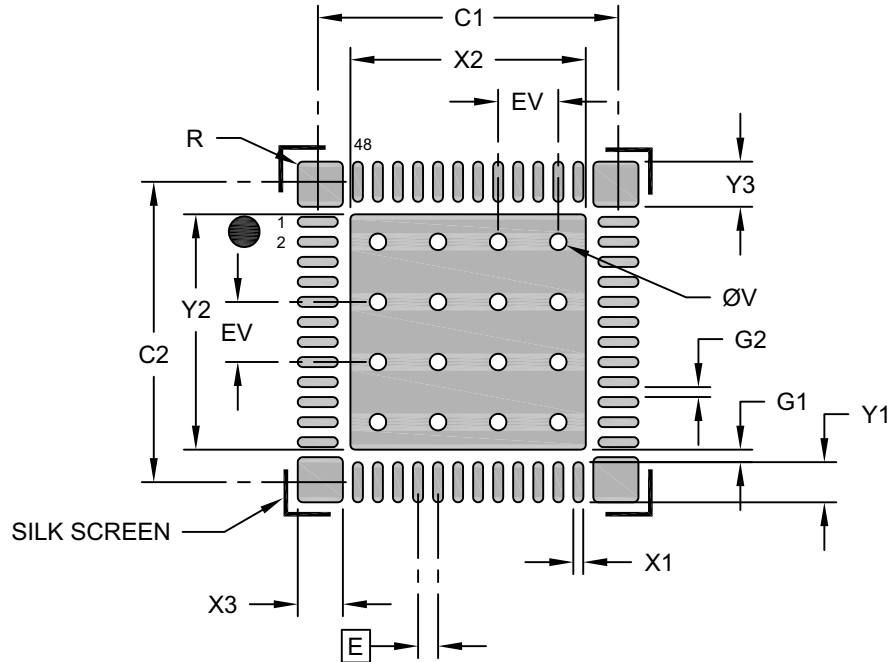

RECOMMENDED LAND PATTERN

Dimension	Units	MILLIMETERS		
		MIN	NOM	MAX
Contact Pitch	E	0.40 BSC		
Center Pad Width	X2			4.70
Center Pad Length	Y2			4.70
Contact Pad Spacing	C1		6.00	
Contact Pad Spacing	C2		6.00	
Contact Pad Width (X48)	X1			0.20
Contact Pad Length (X48)	Y1			0.80
Corner Anchor Pad Width (X4)	X3			0.90
Corner Anchor Pad Length (X4)	Y3			0.90
Pad Corner Radius (X 20)	R			0.10
Contact Pad to Center Pad (X48)	G1	0.25		
Contact Pad to Contact Pad	G2	0.20		
Thermal Via Diameter	V		0.33	
Thermal Via Pitch	EV		1.20	

Notes:

- Dimensioning and tolerancing per ASME Y14.5M
BSC: Basic Dimension. Theoretically exact value shown without tolerances.
- For best soldering results, thermal vias, if used, should be filled or tented to avoid solder loss during reflow process

Microchip Technology Drawing C04-2442A-M4

PIC24FJ256GA705 FAMILY

48-Lead Plastic Thin Quad Flatpack (PT) - 7x7x1.0 mm Body [TQFP]

Note: For the most current package drawings, please see the Microchip Packaging Specification located at <http://www.microchip.com/packaging>

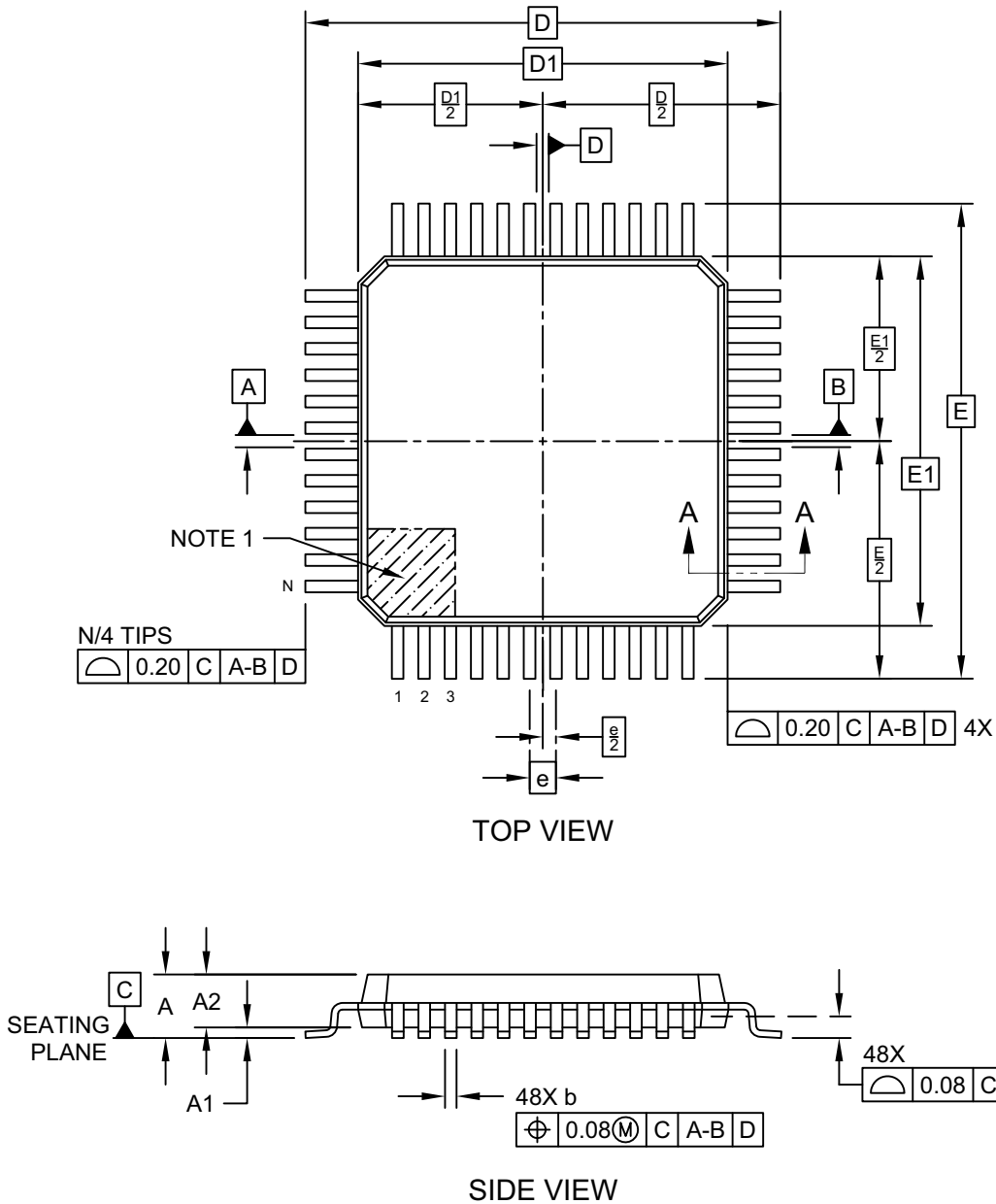

Microchip Technology Drawing C04-300-PT Rev D Sheet 1 of 2

PIC24FJ256GA705 FAMILY

48-Lead Plastic Thin Quad Flatpack (PT) - 7x7x1.0 mm Body [TQFP]

Note: For the most current package drawings, please see the Microchip Packaging Specification located at <http://www.microchip.com/packaging>

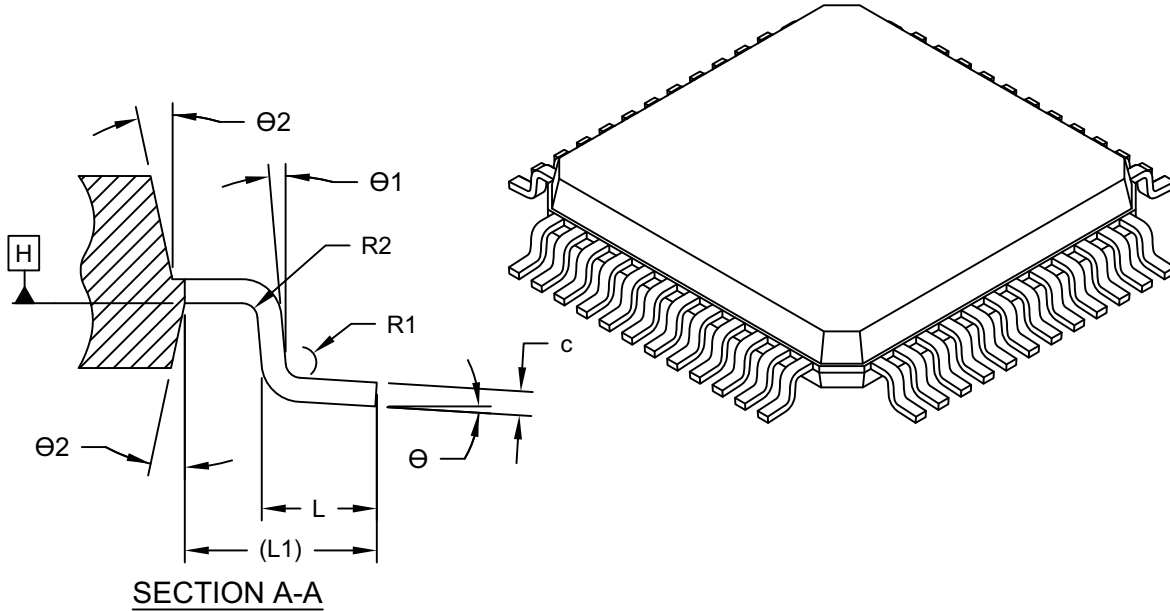

Dimension Limits	Units	MILLIMETERS		
		MIN	NOM	MAX
Number of Terminals	N	48		
Pitch	e	0.50 BSC		
Overall Height	A	-	-	1.20
Standoff	A1	0.05	-	0.15
Molded Package Thickness	A2	0.95	1.00	1.05
Overall Length	D	9.00 BSC		
Molded Package Length	D1	7.00 BSC		
Overall Width	E	9.00 BSC		
Molded Package Width	E1	7.00 BSC		
Terminal Width	b	0.17	0.22	0.27
Terminal Thickness	c	0.09	-	0.16
Terminal Length	L	0.45	0.60	0.75
Footprint	L1	1.00 REF		
Lead Bend Radius	R1	0.08	-	-
Lead Bend Radius	R2	0.08	-	0.20
Foot Angle	Θ	0°	3.5°	7°
Lead Angle	Θ1	0°	-	-
Mold Draft Angle	Θ2	11°	12°	13°

Notes:

- Pin 1 visual index feature may vary, but must be located within the hatched area.
- Dimensioning and tolerancing per ASME Y14.5M
 BSC: Basic Dimension. Theoretically exact value shown without tolerances.
 REF: Reference Dimension, usually without tolerance, for information purposes only.

Microchip Technology Drawing C04-300-PT Rev D Sheet 2 of 2

PIC24FJ256GA705 FAMILY

48-Lead Plastic Thin Quad Flatpack (PT) - 7x7x1.0 mm Body [TQFP]

Note: For the most current package drawings, please see the Microchip Packaging Specification located at <http://www.microchip.com/packaging>

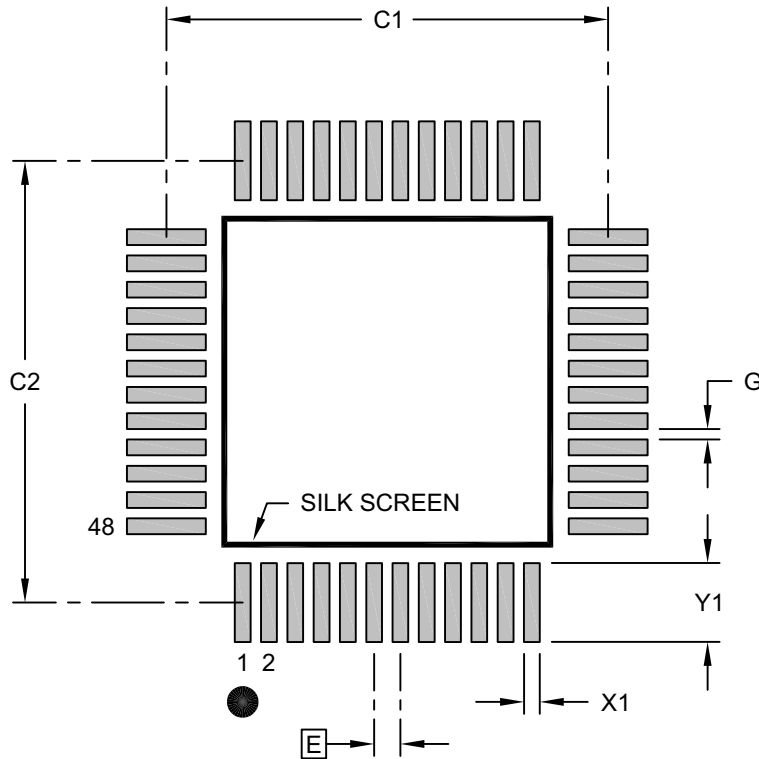

RECOMMENDED LAND PATTERN

Dimension Limits	Units	MILLIMETERS		
		MIN	NOM	MAX
Contact Pitch	E	0.50 BSC		
Contact Pad Spacing	C1		8.40	
Contact Pad Spacing	C2		8.40	
Contact Pad Width (X48)	X1			0.30
Contact Pad Length (X48)	Y1			1.50
Distance Between Pads	G	0.20		

Notes:

- Dimensioning and tolerancing per ASME Y14.5M
BSC: Basic Dimension. Theoretically exact value shown without tolerances.
- For best soldering results, thermal vias, if used, should be filled or tented to avoid solder loss during reflow process

Microchip Technology Drawing C04-2300-PT Rev D

APPENDIX A: REVISION HISTORY

Revision A (March 2016)

Original data sheet for the PIC24FJ256GA705 family of devices.

Revision B (October 2016)

This revision incorporates the following updates:

- Sections:
 - Removes **Section 9.5 “FRC Active Clock Tuning”**.
 - Updates the Absolute Maximum Ratings in **Section 32.0 “Electrical Characteristics”**.
 - Changes the 48-Lead QFN (7x7 mm) to 48-Lead UQFN (6x6 mm) in **Section 33.0 “Packaging Information”**.
- Registers:
 - Updates [Register 9-1](#), [Register 9-3](#), [Register 9-6](#), [Register 16-5](#) and [Register 16-6](#)
- Tables:
 - Adds [Table 11-3](#), [Table 11-4](#) and [Table 11-5](#).
 - Updates the GPIO column in the Peripheral Features table on [Page 2](#).
 - Updates [Table 2](#), [Table 3](#), [Table 4](#), [Table 5](#), [Table 6](#), [Table 32-4](#), [Table 32-5](#), [Table 32-6](#), [Table 32-7](#) and [Table 32-35](#).
- Figures
 - Updates [Figure 9-1](#).
- Changes to text and formatting were incorporated throughout the document.

Revision C (March 2018)

This revision incorporates the following updates which also includes “**Data Sheet Clarifications**” listed in *PIC24FJ256GA705 Family Silicon Errata and Data Sheet Clarification* (DS80000718):

- Sections:
 - Updates **“Referenced Sources”**, **Section 5.0 “Direct Memory Access Controller (DMA)”**, **Section 5.4 “DMA Registers”**, **Section 9.7.2 “Crystal Selection”**, **Section 10.2.4 “Low-Voltage Retention Regulator”**, **Section 21.0 “Real-Time Clock and Calendar (RTCC) with Timestamp”**, **Section 29.2 “Unique Device Identifier (UDID)”** and **Section 29.8 “Customer OTP Memory”**.
 - Replaces the 28-Pin UQFN **M6** drawings with 28-Pin UQFN **MV** drawings in **Section 33.0 “Packaging Information”**; therefore, **“Product Identification System”** is also updated.
- Tables:
 - Updates [Table 1](#), [Table 1-3](#), [Table 8-2](#), [Table 10-1](#), [Table 16-2](#), [Table 29-5](#), [Table 31-1](#), [Table 32-12](#) and [Table 32-34](#).
- Registers:
 - Updates [Register 8-6](#), [Register 10-2](#), [Register 14-1](#), [Register 16-1](#), [Register 17-1](#), [Register 17-5](#), [Register 19-2](#), [Register 22-3](#), [Register 22-4](#), [Register 26-1](#), [Register 27-3](#) and [Register 28-1](#)
- Figures:
 - Updates [Figure 17-1](#), [Figure 18-1](#), [Figure 26-1](#) and [Figure 28-1](#).
- Example:
 - Updates [Example 19-1](#).

Revision D (October 2018)

This revision is updated with the Extended Operating Ambient Temperature Range of the device, specifically the following tables:

- [Table 32-1](#)
- [Table 32-4](#)
- [Table 32-5](#)
- [Table 32-6](#)
- [Table 32-7](#)
- [Table 32-11](#)
- [Table 32-20](#)

PIC24FJ256GA705 FAMILY

Revision E (March 2020)

This revision incorporates the following updates:

- Sections
 - Adds Qualification and Class B Support information to page 1.
 - Updates the notes in all pin diagrams, updates [Section 4.1.1 “Program Memory Organization”](#) and [Section 6.4 “Enhanced In-Circuit Serial Programming”](#).
 - Removes all references of the CCPxSTATH status register.
- Tables:
 - Updates [Table 4-1](#), [Table 4-6](#), [Table 4-7](#), [Table 8-1](#), [Table 8-2](#) and [Table 10-1](#).
 - Adds [Table 32-24](#) through [Table 32-33](#).
- Figures:
 - Updates [Figure 3-2](#).
 - Adds [Figure 32-5](#) through [Figure 32-18](#).
- Registers:
 - Updates [Register 7-1](#).

INDEX

A

A/D

Achieving Maximum Performance	289
Control Registers	288
Extended DMA Operations	287
Operation	285
Transfer Functions	
10-Bit	305
12-Bit	304

AC Characteristics

A/D Conversion Timing Requirements.....	385
A/D Specifications.....	384
and Timing Parameters.....	367
Capacitive Loading on Output Pins.....	367
CLKO and I/O Timing Requirements	370
External Clock Timing Requirements.....	368
I2Cx Bus Data Requirements (Master Mode).....	381
I2Cx Bus Data Requirements (Slave Mode).....	383
Input Capture x Characteristics.....	373
Internal RC Accuracy.....	369
Load Conditions for Device Timing	367
MCCP/SCCP Input Capture x	
Mode Requirements	375
MCCP/SCCP PWM Mode Requirements	375
MCCP/SCCP Timer Mode Requirements.....	374
Phase-Locked Loop Mode Specifications.....	369
PWM Timing Requirements	373
RC Oscillator Start-up Time	369
Reset and Brown-out Reset Requirements	371
SPIx Master Mode Requirements	377
SPIx Module Slave Mode Timing Requirements	379
Timer1 External Clock Timing	372

Analog/Digital Pins Configuration During ICSP	34
---	----

B

Block Diagrams

12-Bit A/D Converter	286
12-Bit A/D Converter Analog Input Model.....	303
16-Bit Asynchronous Timer3.....	163
16-Bit Synchronous Timer2	163
16-Bit Timer1 Module.....	159
32-Bit Timer Mode	186
Access Program Memory Using	
Table Instructions	60
Addressing for Table Registers.....	71
Buffer Address Generation in PIA Mode.....	290
CALL Stack Frame	57
CLCx Input Source Selection.....	277
CLCx Logic Function Combinatorial Options	276
CLCx Module	275
Comparator Voltage Reference	313
Conceptual MCCPx Module.....	183
CPU Programmer's Model.....	37
CRC Module	269
CRC Shift Engine Detail.....	269
CTMU Connections and Internal Configuration	
for Capacitance Measurement.....	316
CTMU Typical Connections and Internal	
Configuration for Pulse Delay Generation	317
CTMU Typical Connections and Internal	
Configuration for Time Measurement	317

Data Access from Program Space Address

Generation.....	59
DMA Module.....	63
Dual 16-Bit Timer Mode.....	185
EDS Address Generation for Read Operations.....	55
EDS Address Generation for Write Operations	56
High/Low-Voltage Detect (HLVD).....	325
I2Cx Module	220
Individual Comparator Configurations, CREF = 0	308
Individual Comparator Configurations, CREF = 1,	
CVREFP = 0.....	308
Individual Comparator Configurations, CREF = 1,	
CVREFP = 1.....	309
Input Capture x Module	167, 188
MCLR Pin Connection Example	30
On-Chip Regulator Connections.....	339
Oscillator Circuit Placement	33
Output Compare x (16-Bit Mode)	174
Output Compare x (Double-Buffered).....	176
Output Compare x Module	187
PIC24F CPU Core.....	36
PIC24FJ256GA705 Family (General).....	19
PLL Module	108
PSV Operation (Lower Word).....	62
PSV Operation (Upper Word).....	62
Recommended Minimum Connections.....	29
Reset System	79
RTCC Module.....	250
Shared I/O Port Structure	125
SPIx Master, Frame Master Connection	217
SPIx Master, Frame Slave Connection	218
SPIx Master/Slave Connection	
(Enhanced Buffer Modes).....	216
SPIx Master/Slave Connection (Standard Mode).....	215
SPIx Module (Enhanced Mode).....	201
SPIx Slave, Frame Master Connection	218
SPIx Slave, Frame Slave Connection	218
System Clock.....	97
Timer Clock Generator	184
Timer2/3 (32-Bit).....	162
Triple Comparator Module.....	307
UARTx (Simplified).....	228
Watchdog Timer (WDT).....	341

C

Capture/Compare/PWM/Timer

Auxiliary Output	189
General Purpose Timer	185
Input Capture Mode.....	188
Output Compare Mode	186
Synchronization Sources	193
Time Base Generator	184
Capture/Compare/PWM/Timer (MCCP)	183
Charge Time Measurement Unit. See CTMU.	
CLC	
Control Registers.....	278
Module-Specific Input Sources.....	281

PIC24FJ256GA705 FAMILY

Code Examples	
Basic Clock Switching	107
Configuring UART1 Input/Output Functions	140
Double-Word Flash Programming (C Language)	78
EDS Read from Program Memory in Assembly	61
EDS Read in Assembly	55
EDS Write in Assembly	56
Erasing a Program Memory Block (C Language)	75
Initiating a Programming Sequence	76
IOC Status Read/Clear in Assembly	128
Port Read/Write in Assembly	128
Port Read/Write in C	128
PWRSAV Instruction Syntax	113
Setting the WRLOCK Bit	251
Code Memory Programming Example	
Double-Word Programming	77
Page Erase	74
Row Writes	75
Code Protection	342
Comparator Voltage Reference	313
Configuring	313
Configurable Logic Cell (CLC)	275
Configurable Logic Cell. <i>See</i> CLC.	
Configuration Bits	327
Core Features	15
CPU	35
Arithmetic Logic Unit (ALU)	40
Clocking Scheme	98
Control Registers	38
Core Registers	36
Programmer's Model	35
CRC	
Data Shift Direction	271
Interrupt Operation	271
Polynomials	270
Setup Examples for 16 and 32-Bit Polynomials	270
Typical Operation	271
User Interface	270
CTMU	
Measuring Capacitance	315
Measuring Die Temperature	318
Measuring Time/Routing Current to	
A/D Input Pin	316
Pulse Generation and Delay	316
Customer Change Notification Service	419
Customer Notification Service	419
Customer OTP Memory	342
Customer Support	419
Cyclic Redundancy Check. <i>See</i> CRC.	
D	
Data Memory Space	45
Extended Data Space (EDS)	54
Memory Map	45
Near Data Space	46
Organization, Alignment	46
SFR Space	46
Implemented Regions	46
Map, 0000h Block	47
Map, 0100h Block	48
Map, 0200h Block	49
Map, 0300h Block	50
Map, 0400h Block	51
Map, 0500h Block	52
Map, 0600h Block	52
Map, 0700h Block	53
Software Stack	57
DC Characteristics	
Comparator Specifications	366
Comparator Voltage Reference Specifications	366
CTMU Current Source	366
Δ Current (BOR, WDT, HLVD, RTCC)	361
High/Low-Voltage Detect	365
I/O Pin Input Specifications	363
I/O Pin Output Specifications	364
Idle Current (IDLE)	358
Internal Voltage Regulator Specifications	365
Operating Current (IDD)	356
Power-Down Current (IPD)	360
Program Memory	364
Temperature and Voltage Specifications	355
Thermal Operating Conditions	354
Thermal Packaging	354
Development Support	343
Device Features	
28-Pin Devices	17
44/48-Pin Devices	18
Direct Memory Access Controller. <i>See</i> DMA.	
DMA	
Channel Trigger Sources	70
Control Registers	66
Peripheral Module Disable (PMD) Registers	66
Summary of Operations	64
Types of Data Transfers	65
Typical Setup	66
DMA Controller	16
E	
Electrical Characteristics	353
Absolute Maximum Ratings	353
V/F Graph (Industrial)	354
Enhanced Parallel Master Port (EPMP)	237
Enhanced Parallel Master Port. <i>See</i> EPMP.	
EPMP	
Key Features	237
Memory Addressable in Different Modes	238
Pin Descriptions	239
PMDIN1 and PMDIN2 Registers	238
PMDOUT1 and PMDOUT2 Registers	238
Equations	
16-Bit, 32-Bit CRC Polynomials	270
A/D Conversion Clock Period	303
Baud Rate Reload Calculation	221
Calculating the PWM Period	176
Calculation for Maximum PWM Resolution	177
Relationship Between Device and	
SPIx Clock Speed	218
UARTx Baud Rate with BRGH = 0	229
UARTx Baud Rate with BRGH = 1	229
Errata	12
Extended Data Space (EDS)	237
External Oscillator Pins	33

PIC24FJ256GA705 FAMILY

F			
Flash Program Memory	71	Resources	90
and Table Instructions.....	71	Interrupt-on-Change (IOC).....	128
Control Registers	72	Interrupts	
Double-Word Programming	77	Trap Vectors	86
Enhanced ICSP Operation.....	72	Vector Tables	86
JTAG Operation	72	J	
Operations	72	JTAG Interface	342
Programming Algorithm	74	K	
RTSP Operation.....	72	Key Features	327
G		L	
Guidelines for Getting Started with 16-Bit MCUs	29	Low-Voltage Retention Regulator.....	339
H		M	
High/Low-Voltage Detect (HLVD)	325	Memory Organization	41
High/Low-Voltage Detect. See HLVD.		Program Memory Space.....	41
I		Microchip Internet Web Site.....	419
I/O Ports	125	N	
Analog Port Pins Configuration (ANSx)	126	Near Data Space	46
Configuring Analog/Digital Function of I/O Pins.....	126	O	
Control Registers	129	On-Chip Voltage Regulator.....	339
Input Voltage Levels for Port/Pin Tolerated		POR	339
Description Input.....	126	Standby Mode	339
Open-Drain Configuration	126	Oscillator Configuration	97
Parallel (PIO)	125	Clock Switching	106
Peripheral Pin Select	136	Sequence	106
PORTA Pin and ANSELx Availability	127	Configuration Bit Values for Clock Selection	99
PORTB Pin and ANSELx Availability.....	127	Control Registers.....	99
PORTC Pin and ANSELx Availability.....	127	Initial Configuration on POR.....	98
Write/Read Timing	126	Modes.....	108
i ² C		Output Compare with Dedicated Timers.....	173
Clock Rates.....	221	Operating Modes	173
Communicating as Master in Single		32-Bit Cascaded Mode	173
Master Environment.....	219	Synchronous and Trigger Modes	173
Reserved Addresses.....	221	Operations	174
Setting Baud Rate as Bus Master.....	221	P	
Slave Address Masking	221	Packaging	
ICSP Pins.....	32	Details.....	389
In-Circuit Debugger	342	Marking.....	387
Input Capture		Peripheral Enable Bits	115
32-Bit Cascaded Mode	168	Peripheral Module Disable Bits.....	115
Operations	168	Peripheral Pin Select (PPS).....	136
Synchronous and Trigger Modes.....	167	Available Peripherals and Pins.....	136
Input Capture with Dedicated Timers.....	167	Configuration Control.....	139
Instruction Set		Considerations for Selection.....	140
Overview	347	Control Registers.....	141
Summary.....	345	Input Mapping	137
Symbols Used in Opcode Descriptions.....	346	Mapping Exceptions	139
Interfacing Program and Data Memory Spaces	58	Output Mapping	138
Inter-Integrated Circuit. See I ² C.		Peripheral Priority	136
Internet Address	419	Selectable Input Sources.....	137
Interrupt Controller	85	Selectable Output Sources.....	138
Alternate Interrupt Vector Table (AIVT)	85	PIC24FJ256GA705 Family Pinout Descriptions	20
Control and Status Registers	90	Pin Descriptions	
IEC0-IEC7.....	90	28-Pin QFN, UQFN Devices.....	3
IFS0-IFS7	90	28-Pin SOIC, SSOP, SPDIP Devices.....	4
INTCON1	90	44-Pin TQFP Devices.....	6
INTCON2	90	48-Pin TQFP Devices.....	10
INTCON4	90	48-Pin UQFN Devices	8
INTTREG	90		
IPC0-IPC29.....	90		
Interrupt Vector Details	87		
Interrupt Vector Table (IVT)	85		
Reset Sequence	85		

PIC24FJ256GA705 FAMILY

Power-Saving Features.....	113	CLKDIV (Clock Divider).....	102
Clock Frequency, Clock Switching.....	113	CMSTAT (Comparator Module Status).....	311
Doze Mode.....	115	CMxCON (Comparator x Control, Comparators 1 Through 3).....	310
Instruction-Based Modes.....	113	CORCON (CPU Core Control).....	39, 92
Idle.....	114	CRCCON1 (CRC Control 1).....	272
Sleep.....	113	CRCCON2 (CRC Control 2).....	273
Low-Voltage Retention Regulator.....	114	CRCXORH (CRC XOR Polynomial, High Word).....	274
Selective Peripheral Module Control.....	115	CRCXORL (CRC XOR Polynomial, Low Word).....	274
Product Identification System.....	421	CTMUCON1H (CTMU Control 1 High).....	321
Program Memory Space		CTMUCON1L (CTMU Control 1 Low).....	319
Access Using Table Instructions.....	60	CTMUCON2L (CTMU Control 2 Low).....	323
Addressing.....	58	CVRCON (Comparator Voltage Reference Control).....	314
Configuration Bits		DATEH (RTCC Date High).....	259
Code-Protect.....	44	DATEL (RTCC Date Low).....	259
Overview.....	43	DMACHn (DMA Channel n Control).....	68
Configuration Word Addresses.....	43	DMACON (DMA Engine Control).....	67
Customer OTP Memory.....	44	DMAINTn (DMA Channel n Interrupt).....	69
Hard Memory Vectors.....	43	FBSLIM Configuration.....	329
Memory Map.....	42	FDEOPT1 Configuration.....	337
Organization.....	43	FICD Configuration.....	336
Reading Data Using EDS.....	61	FOSC Configuration.....	332
Sizes and Boundaries.....	42	FOSCSEL Configuration.....	331
Program Verification.....	342	FPOR Configuration.....	335
Pulse-Width Modulation (PWM) Mode.....	175	FSEC Configuration.....	328
Pulse-Width Modulation. See PWM.		FSIGN Configuration.....	330
PWM		FWDT Configuration.....	333
Duty Cycle and Period.....	176	HLVDCON (High/Low-Voltage Detect Control).....	326
R		I2CxCONH (I2Cx Control High).....	224
Real-Time Clock and Calendar (RTCC).....	249	I2CxCONL (I2Cx Control Low).....	222
Reference Clock Output.....	109	I2CxMSK (I2Cx Slave Mode Address Mask).....	226
Referenced Sources.....	13	I2CxSTAT (I2Cx Status).....	225
Register Summary		ICxCON1 (Input Capture x Control 1).....	169
Peripheral Module Disable (PMD).....	116	ICxCON2 (Input Capture x Control 2).....	170
Registers		INTCON1 (Interrupt Control 1).....	93
AD1CHITL (A/D Scan Compare Hit, Low Word).....	300	INTCON2 (Interrupt Control 2).....	94
AD1CHS (A/D Sample Select).....	298	INTCON4 (Interrupt Control 4).....	95
AD1CON1 (A/D Control 1).....	291	INTTREG (Interrupt Control and Status).....	96
AD1CON2 (A/D Control 2).....	293	IOCFx (Interrupt-on-Change Flag x).....	134
AD1CON3 (A/D Control 3).....	295	IOCNx (Interrupt-on-Change Negative Edge x).....	133
AD1CON4 (A/D Control 4).....	296	IOCPDx (Interrupt-on-Change Pull-Down Enable x).....	135
AD1CON5 (A/D Control 5).....	297	IOCPUx (Interrupt-on-Change Pull-up Enable x).....	134
AD1CSSL (A/D Input Scan Select, Low Word).....	301	IOCPx (Interrupt-on-Change Positive Edge x).....	133
AD1CTMENH (A/D CTMU Enable, High Word).....	302	IOCSTAT (Interrupt-on-Change Status).....	129
AD1CTMENL (A/D CTMU Enable, Low Word).....	302	LATx (Output Data for PORTx).....	131
ALMDATEH (RTCC Alarm Date High).....	261	NVMCON (Flash Memory Control).....	73
ALMDATEL (RTCC Alarm Date Low).....	261	OCxCON1 (Output Compare x Control 1).....	178
ALMTIMEH (RTCC Alarm Time High).....	260	OCxCON2 (Output Compare x Control 2).....	180
ALMTIMEL (RTCC Alarm Time Low).....	260	ODCx (Open-Drain Enable for PORTx).....	131
ANCFG (A/D Band Gap Reference Configuration).....	299	OSCCON (Oscillator Control).....	100
ANSELx (Analog Select for PORTx).....	132	OSCDIV (Oscillator Divisor).....	104
CCPxCON1H (CCPx Control 1 High).....	192	OSCFDIV (Oscillator Fractional Divisor).....	105
CCPxCON1L (CCPx Control 1 Low).....	190	OSCTUN (FRC Oscillator Tune).....	103
CCPxCON2H (CCPx Control 2 High).....	195	PADCON (Pad Configuration Control).....	248
CCPxCON2L (CCPx Control 2 Low).....	194	PADCON (Port Configuration).....	129
CCPxCON3H (CCPx Control 3 High).....	197	PMCON1 (EPMP Control 1).....	240
CCPxCON3L (CCPx Control 3 Low).....	196	PMCON2 (EPMP Control 2).....	241
CCPxSTATL (CCPx Status Low).....	198	PMCON3 (EPMP Control 3).....	242
CLCxCONH (CLCx Control High).....	279	PMCON4 (EPMP Control 4).....	243
CLCxCONL (CLCx Control Low).....	278	PMCSxBS (EPMP Chip Select x Base Address).....	245
CLCxGLSH (CLCx Gate Logic Input Select High).....	283	PMCSxCF (EPMP Chip Select x Configuration).....	244
CLCxGLSL (CLCx Gate Logic Input Select Low).....	281	PMCSxMD (EPMP Chip Select x Mode).....	246
CLCxSEL (CLCx Input MUX Select).....	280	PMD1 (Peripheral Module Disable 1).....	117

PIC24FJ256GA705 FAMILY

PMD2 (Peripheral Module Disable 2)	118	T1CON (Timer1 Control)	160
PMD3 (Peripheral Module Disable 3)	119	TIMEH (RTCC Time High)	258
PMD4 (Peripheral Module Disable 4)	120	TIMEL (RTCC Time Low)	258
PMD5 (Peripheral Module Disable 5)	121	TRISx (Output Enable for PORTx)	130
PMD6 (Peripheral Module Disable 6)	122	TSADATEH (RTCC Timestamp A Date High)	265
PMD7 (Peripheral Module Disable 7)	122	TSADATEL (RTCC Timestamp A Date Low)	264
PMD8 (Peripheral Module Disable 8)	123	TSATIMEH (RTCC Timestamp A Time High)	263
PMSTAT (EPMP Status, Slave Mode)	247	TSATIMEL (RTCC Timestamp A Time Low)	262
PORTx (Input Data for PORTx)	130	TxCON (Timer2 Control)	164
RCON (Reset Control)	80	TyCON (Timer3 Control)	166
REFOCONH (Reference Oscillator Control High)	111	UxADMD (UARTx Address Detect and Match)	236
REFOCONL (Reference Oscillator Control Low)	110	UxBRG (UARTx Baud Rate Generator)	236
RPINR0 (Peripheral Pin Select Input 0)	141	UxMODE (UARTx Mode)	231
RPINR1 (Peripheral Pin Select Input 1)	141	UxRXREG (UARTx Receive, Normally Read-Only)	235
RPINR11 (Peripheral Pin Select Input 11)	145	UxSTA (UARTx Status and Control)	233
RPINR12 (Peripheral Pin Select Input 12)	145	UxTXREG (UARTx Transmit, Normally Write-Only)	235
RPINR18 (Peripheral Pin Select Input 18)	146		
RPINR19 (Peripheral Pin Select Input 19)	146		
RPINR2 (Peripheral Pin Select Input 2)	142	Resets	
RPINR20 (Peripheral Pin Select Input 20)	147	BOR (Brown-out Reset)	79
RPINR21 (Peripheral Pin Select Input 21)	147	Brown-out Reset (BOR)	82
RPINR22 (Peripheral Pin Select Input 22)	148	Clock Source Selection	82
RPINR23 (Peripheral Pin Select Input 23)	148	CM (Configuration Mismatch Reset)	79
RPINR25 (Peripheral Pin Select Input 25)	149	Delay Times	83
RPINR28 (Peripheral Pin Select Input 28)	149	Device Times	82
RPINR29 (Peripheral Pin Select Input 29)	150	IOPUWR (Illegal Opcode Reset)	79
RPINR3 (Peripheral Pin Select Input 3)	142	MCLR (Master Clear Pin Reset)	79
RPINR5 (Peripheral Pin Select Input 5)	143	POR (Power-on Reset)	79
RPINR6 (Peripheral Pin Select Input 6)	143	RCON Flags, Operation	81
RPINR7 (Peripheral Pin Select Input 7)	144	SFR States	82
RPINR8 (Peripheral Pin Select Input 8)	144	SWR (RESET Instruction)	79
RPOR0 (Peripheral Pin Select Output 0)	151	TRAPR (Trap Conflict Reset)	79
RPOR1 (Peripheral Pin Select Output 1)	151	UWR (Uninitialized W Register Reset)	79
RPOR10 (Peripheral Pin Select Output 10)	156	WDT (Watchdog Timer Reset)	79
RPOR11 (Peripheral Pin Select Output 11)	156	Revision History	411
RPOR12 (Peripheral Pin Select Output 12)	157	RTCC	
RPOR13 (Peripheral Pin Select Output 13)	157	Alarm Configuration	266
RPOR14 (Peripheral Pin Select Output 14)	158	Alarm Mask Settings (figure)	267
RPOR2 (Peripheral Pin Select Output 2)	152	Alarm Value Registers	260
RPOR3 (Peripheral Pin Select Output 3)	152	Calibration	266
RPOR4 (Peripheral Pin Select Output 4)	153	Clock Source Selection	251
RPOR5 (Peripheral Pin Select Output 5)	153	Control Registers	252
RPOR6 (Peripheral Pin Select Output 6)	154	Event Timestamping	268
RPOR7 (Peripheral Pin Select Output 7)	154	Module Registers	251
RPOR8 (Peripheral Pin Select Output 8)	155	Power Control	267
RPOR9 (Peripheral Pin Select Output 9)	155	Register Mapping	251
RTCCON1H (RTCC Control 1 High)	253	RTCVAl Register Mappings	255
RTCCON1L (RTCC Control 1 Low)	252	Source Clock	249
RTCCON2H (RTCC Control 2 High)	255	Timestamp Registers	262
RTCCON2L (RTCC Control 2 Low)	254	Value Registers	258
RTCCON3L (RTCC Control 3 Low)	256	Write Lock	251
RTCSTATL (RTCC Status Low)	257		
SPIxBRGL (SPIx Baud Rate Generator Low)	211	S	
SPIxBUFH (SPIx Buffer High)	210	Secondary Oscillator Operation	109
SPIxBUFL (SPIx Buffer Low)	210	Serial Peripheral Interface (SPI)	199
SPIxCON1H (SPIx Control 1 High)	204	Serial Peripheral Interface. See SPI.	
SPIxCON1L (SPIx Control 1 Low)	202	Software Stack	57
SPIxCON2L (SPIx Control 2 Low)	206	Special Features	16, 327
SPIxIMSKH (SPIx Interrupt Mask High)	213	SPI	
SPIxIMSKL (SPIx Interrupt Mask Low)	212	Audio Mode Operation	201
SPIxSTATH (SPIx Status High)	209	Control Registers	202
SPIxSTATL (SPIx Status Low)	207	Master Mode Operation	200
SPIxURDTH (SPIx Underrun Data High)	214	Slave Mode Operation	200
SPIxURDTL (SPIx Underrun Data Low)	214	Summary of Low-Power Sleep Modes	114
SR (ALU STATUS)	38, 91		

PIC24FJ256GA705 FAMILY

T

Timer1	159
Timer2/3	161
Timing Diagrams	
CLKO and I/O Characteristics	370
External Clock	368
I2Cx Bus Data (Master Mode)	380
I2Cx Bus Data (Slave Mode)	382
I2Cx Bus Start/Stop Bits (Master Mode)	380
I2Cx Bus Start/Stop Bits (Slave Mode)	382
Input Capture x	373
MCCP/SCCP Input Capture x Mode	375
MCCP/SCCP PWM Mode Characteristics	375
MCCP/SCCP Timer Mode External Clock	374
PWM Requirements	373
SPIx Master Mode (CKE = 0)	376
SPIx Master Mode (CKE = 1)	376
SPIx Slave Mode (CKE = 0)	378
SPIx Slave Mode (CKE = 1)	378
Timer1 External Clock Characteristics	372
Triple Comparator	307
Triple Comparator Module	307

U

UART	227
Baud Rate Generator (BRG)	229
Infrared Support	230
Operation of UxCTS and UxRTS Pins	230
Receiving	
8-Bit or 9-Bit Data Mode	230
Transmitting	
8-Bit Data Mode	230
9-Bit Data Mode	230
Break and Sync Sequence	230
Unique Device Identifier (UDID)	338
Universal Asynchronous Receiver Transmitter. <i>See</i> UART.	
Unused I/Os	34

V

Voltage Regulator Pin (VCAP)	31
------------------------------------	----

W

Watchdog Timer (WDT)	340
Control Register	340
Windowed Operation	340
WWW Address	419
WWW, On-Line Support	12

THE MICROCHIP WEBSITE

Microchip provides online support via our WWW site at www.microchip.com. This website is used as a means to make files and information easily available to customers. Accessible by using your favorite Internet browser, the website contains the following information:

- **Product Support** – Data sheets and errata, application notes and sample programs, design resources, user's guides and hardware support documents, latest software releases and archived software
- **General Technical Support** – Frequently Asked Questions (FAQ), technical support requests, online discussion groups, Microchip consultant program member listing
- **Business of Microchip** – Product selector and ordering guides, latest Microchip press releases, listing of seminars and events, listings of Microchip sales offices, distributors and factory representatives

CUSTOMER CHANGE NOTIFICATION SERVICE

Microchip's customer notification service helps keep customers current on Microchip products. Subscribers will receive e-mail notification whenever there are changes, updates, revisions or errata related to a specified product family or development tool of interest.

To register, access the Microchip website at www.microchip.com. Under "Support", click on "Customer Change Notification" and follow the registration instructions.

CUSTOMER SUPPORT

Users of Microchip products can receive assistance through several channels:

- Distributor or Representative
- Local Sales Office
- Field Application Engineer (FAE)
- Technical Support

Customers should contact their distributor, representative or Field Application Engineer (FAE) for support. Local sales offices are also available to help customers. A listing of sales offices and locations is included in the back of this document.

Technical support is available through the website at: <http://microchip.com/support>

PIC24FJ256GA705 FAMILY

NOTES:

PIC24FJ256GA705 FAMILY

PRODUCT IDENTIFICATION SYSTEM

To order or obtain information, e.g., on pricing or delivery, refer to the factory or the listed sales office.

<p style="text-align: center;">PIC 24 FJ 256 GA7 05 T - I / PT - XXX</p> <p>Microchip Trademark _____</p> <p>Architecture _____</p> <p>Flash Memory Family _____</p> <p>Program Memory Size (Kbytes) _____</p> <p>Product Group _____</p> <p>Pin Count _____</p> <p>Tape and Reel Flag (if applicable) _____</p> <p>Temperature Range _____</p> <p>Package _____</p> <p>Pattern _____</p>	<p>Examples:</p> <p>a) PIC24FJ256GA705-I/PT: PIC24F General Purpose Device, 48-Pin, Industrial Temp., TQFP Package.</p> <p>b) PIC24FJ256GA702-E/ML: PIC24F General Purpose Device, 28-Pin, Extended Temp., QFN Package</p>												
<table style="width: 100%; border-collapse: collapse;"> <tr> <td style="width: 20%;">Architecture</td> <td>24 = 16-Bit Modified Harvard without DSP</td> </tr> <tr> <td>Flash Memory Family</td> <td>FJ = Flash Program Memory</td> </tr> <tr> <td>Pin Count</td> <td>02 = 28-pin (QFN, UQFN, SOIC, SSOP, SPDIP) 04 = 44-pin (TQFP) 05 = 48-pin (UQFN, TQFP)</td> </tr> <tr> <td>Temperature Range</td> <td>I = -40°C to +85°C (Industrial) E = -40°C to +125°C (Extended)</td> </tr> <tr> <td>Package</td> <td>ML = 28-Lead (6x6 mm) QFN (Plastic Quad Flat) MV = 28-Lead (4x4x0.6 mm) UQFN (Ultra Thin Quad Flatpack) SO = 28-Lead (7.50 mm) SOIC (Plastic Small Outline) SS = 28-Lead (5.30 mm) SSOP (Plastic Shrink Small Outline) SP = 28-Lead (300 mil) SPDIP (Skinny Plastic Dual In-Line) PT = 44-lead (10x10x1 mm) TQFP (Thin Quad Flatpack) M4 = 48-Lead (6X6 mm) UQFN (Plastic Quad Flat) PT = 48-Lead (7x7x1 mm) TQFP (Thin Quad Flatpack)</td> </tr> <tr> <td>Pattern</td> <td>QTP, SQTP, Code or Special Requirements (blank otherwise) ES = Engineering Sample</td> </tr> </table>		Architecture	24 = 16-Bit Modified Harvard without DSP	Flash Memory Family	FJ = Flash Program Memory	Pin Count	02 = 28-pin (QFN, UQFN, SOIC, SSOP, SPDIP) 04 = 44-pin (TQFP) 05 = 48-pin (UQFN, TQFP)	Temperature Range	I = -40°C to +85°C (Industrial) E = -40°C to +125°C (Extended)	Package	ML = 28-Lead (6x6 mm) QFN (Plastic Quad Flat) MV = 28-Lead (4x4x0.6 mm) UQFN (Ultra Thin Quad Flatpack) SO = 28-Lead (7.50 mm) SOIC (Plastic Small Outline) SS = 28-Lead (5.30 mm) SSOP (Plastic Shrink Small Outline) SP = 28-Lead (300 mil) SPDIP (Skinny Plastic Dual In-Line) PT = 44-lead (10x10x1 mm) TQFP (Thin Quad Flatpack) M4 = 48-Lead (6X6 mm) UQFN (Plastic Quad Flat) PT = 48-Lead (7x7x1 mm) TQFP (Thin Quad Flatpack)	Pattern	QTP, SQTP, Code or Special Requirements (blank otherwise) ES = Engineering Sample
Architecture	24 = 16-Bit Modified Harvard without DSP												
Flash Memory Family	FJ = Flash Program Memory												
Pin Count	02 = 28-pin (QFN, UQFN, SOIC, SSOP, SPDIP) 04 = 44-pin (TQFP) 05 = 48-pin (UQFN, TQFP)												
Temperature Range	I = -40°C to +85°C (Industrial) E = -40°C to +125°C (Extended)												
Package	ML = 28-Lead (6x6 mm) QFN (Plastic Quad Flat) MV = 28-Lead (4x4x0.6 mm) UQFN (Ultra Thin Quad Flatpack) SO = 28-Lead (7.50 mm) SOIC (Plastic Small Outline) SS = 28-Lead (5.30 mm) SSOP (Plastic Shrink Small Outline) SP = 28-Lead (300 mil) SPDIP (Skinny Plastic Dual In-Line) PT = 44-lead (10x10x1 mm) TQFP (Thin Quad Flatpack) M4 = 48-Lead (6X6 mm) UQFN (Plastic Quad Flat) PT = 48-Lead (7x7x1 mm) TQFP (Thin Quad Flatpack)												
Pattern	QTP, SQTP, Code or Special Requirements (blank otherwise) ES = Engineering Sample												

PIC24FJ256GA705 FAMILY

NOTES:

Note the following details of the code protection feature on Microchip devices:

- Microchip products meet the specification contained in their particular Microchip Data Sheet.
- Microchip believes that its family of products is one of the most secure families of its kind on the market today, when used in the intended manner and under normal conditions.
- There are dishonest and possibly illegal methods used to breach the code protection feature. All of these methods, to our knowledge, require using the Microchip products in a manner outside the operating specifications contained in Microchip's Data Sheets. Most likely, the person doing so is engaged in theft of intellectual property.
- Microchip is willing to work with the customer who is concerned about the integrity of their code.
- Neither Microchip nor any other semiconductor manufacturer can guarantee the security of their code. Code protection does not mean that we are guaranteeing the product as “unbreakable.”

Code protection is constantly evolving. We at Microchip are committed to continuously improving the code protection features of our products. Attempts to break Microchip's code protection feature may be a violation of the Digital Millennium Copyright Act. If such acts allow unauthorized access to your software or other copyrighted work, you may have a right to sue for relief under that Act.

Information contained in this publication regarding device applications and the like is provided only for your convenience and may be superseded by updates. It is your responsibility to ensure that your application meets with your specifications. MICROCHIP MAKES NO REPRESENTATIONS OR WARRANTIES OF ANY KIND WHETHER EXPRESS OR IMPLIED, WRITTEN OR ORAL, STATUTORY OR OTHERWISE, RELATED TO THE INFORMATION, INCLUDING BUT NOT LIMITED TO ITS CONDITION, QUALITY, PERFORMANCE, MERCHANTABILITY OR FITNESS FOR PURPOSE. Microchip disclaims all liability arising from this information and its use. Use of Microchip devices in life support and/or safety applications is entirely at the buyer's risk, and the buyer agrees to defend, indemnify and hold harmless Microchip from any and all damages, claims, suits, or expenses resulting from such use. No licenses are conveyed, implicitly or otherwise, under any Microchip intellectual property rights unless otherwise stated.

Trademarks

The Microchip name and logo, the Microchip logo, Adaptec, AnyRate, AVR, AVR logo, AVR Freaks, BesTime, BitCloud, chipKIT, chipKIT logo, CryptoMemory, CryptoRF, dsPIC, FlashFlex, flexPWR, HELDO, IGLOO, JukeBlox, KeeLoq, Klear, LANCheck, LinkMD, maXStylus, maXTouch, MediaLB, megaAVR, Microsemi, Microsemi logo, MOST, MOST logo, MPLAB, OptoLyzer, PackeTime, PIC, picoPower, PICSTART, PIC32 logo, PolarFire, Prochip Designer, QTouch, SAM-BA, SenGenuity, SpyNIC, SST, SST Logo, SuperFlash, Symmetricom, SyncServer, Tachyon, TempTracker, TimeSource, tinyAVR, UNI/O, Vectron, and XMEGA are registered trademarks of Microchip Technology Incorporated in the U.S.A. and other countries.

APT, ClockWorks, The Embedded Control Solutions Company, EtherSynch, FlashTec, Hyper Speed Control, HyperLight Load, IntelliMOS, Libero, motorBench, mTouch, Powermite 3, Precision Edge, ProASIC, ProASIC Plus, ProASIC Plus logo, Quiet-Wire, SmartFusion, SyncWorld, Temux, TimeCesium, TimeHub, TimePictra, TimeProvider, Vite, WinPath, and ZL are registered trademarks of Microchip Technology Incorporated in the U.S.A.

Adjacent Key Suppression, AKS, Analog-for-the-Digital Age, Any Capacitor, AnyIn, AnyOut, BlueSky, BodyCom, CodeGuard, CryptoAuthentication, CryptoAutomotive, CryptoCompanion, CryptoController, dsPICDEM, dsPICDEM.net, Dynamic Average Matching, DAM, ECAN, EtherGREEN, In-Circuit Serial Programming, ICSP, INICnet, Inter-Chip Connectivity, JitterBlocker, KlearNet, KlearNet logo, memBrain, Mindi, MiWi, MPASM, MPF, MPLAB Certified logo, MPLIB, MPLINK, MultiTRAK, NetDetach, Omniscient Code Generation, PICDEM, PICDEM.net, PICKit, PICtail, PowerSmart, PureSilicon, QMatrix, REAL ICE, Ripple Blocker, SAM-ICE, Serial Quad I/O, SMART-I.S., SQI, SuperSwitcher, SuperSwitcher II, Total Endurance, TSHARC, USBCheck, VariSense, ViewSpan, WiperLock, Wireless DNA, and ZENA are trademarks of Microchip Technology Incorporated in the U.S.A. and other countries.

SQTP is a service mark of Microchip Technology Incorporated in the U.S.A.

The Adaptec logo, Frequency on Demand, Silicon Storage Technology, and Symmcom are registered trademarks of Microchip Technology Inc. in other countries.

GestIC is a registered trademark of Microchip Technology Germany II GmbH & Co. KG, a subsidiary of Microchip Technology Inc., in other countries.

All other trademarks mentioned herein are property of their respective companies.

© 2016-2020, Microchip Technology Incorporated, All Rights Reserved.

ISBN: 978-1-5224-5822-7

For information regarding Microchip's Quality Management Systems, please visit www.microchip.com/quality.



MICROCHIP

Worldwide Sales and Service

AMERICAS

Corporate Office
2355 West Chandler Blvd.
Chandler, AZ 85224-6199
Tel: 480-792-7200
Fax: 480-792-7277
Technical Support:
[http://www.microchip.com/
support](http://www.microchip.com/support)
Web Address:
www.microchip.com

Atlanta

Duluth, GA
Tel: 678-957-9614
Fax: 678-957-1455

Austin, TX

Tel: 512-257-3370

Boston

Westborough, MA
Tel: 774-760-0087
Fax: 774-760-0088

Chicago

Itasca, IL
Tel: 630-285-0071
Fax: 630-285-0075

Dallas

Addison, TX
Tel: 972-818-7423
Fax: 972-818-2924

Detroit

Novi, MI
Tel: 248-848-4000

Houston, TX

Tel: 281-894-5983

Indianapolis

Noblesville, IN
Tel: 317-773-8323
Fax: 317-773-5453
Tel: 317-536-2380

Los Angeles

Mission Viejo, CA
Tel: 949-462-9523
Fax: 949-462-9608
Tel: 951-273-7800

Raleigh, NC

Tel: 919-844-7510

New York, NY

Tel: 631-435-6000

San Jose, CA

Tel: 408-735-9110
Tel: 408-436-4270

Canada - Toronto

Tel: 905-695-1980
Fax: 905-695-2078

ASIA/PACIFIC

Australia - Sydney
Tel: 61-2-9868-6733

China - Beijing
Tel: 86-10-8569-7000

China - Chengdu
Tel: 86-28-8665-5511

China - Chongqing
Tel: 86-23-8980-9588

China - Dongguan
Tel: 86-769-8702-9880

China - Guangzhou
Tel: 86-20-8755-8029

China - Hangzhou
Tel: 86-571-8792-8115

China - Hong Kong SAR
Tel: 852-2943-5100

China - Nanjing
Tel: 86-25-8473-2460

China - Qingdao
Tel: 86-532-8502-7355

China - Shanghai
Tel: 86-21-3326-8000

China - Shenyang
Tel: 86-24-2334-2829

China - Shenzhen
Tel: 86-755-8864-2200

China - Suzhou
Tel: 86-186-6233-1526

China - Wuhan
Tel: 86-27-5980-5300

China - Xian
Tel: 86-29-8833-7252

China - Xiamen
Tel: 86-592-2388138

China - Zhuhai
Tel: 86-756-3210040

ASIA/PACIFIC

India - Bangalore
Tel: 91-80-3090-4444

India - New Delhi
Tel: 91-11-4160-8631

India - Pune
Tel: 91-20-4121-0141

Japan - Osaka
Tel: 81-6-6152-7160

Japan - Tokyo
Tel: 81-3-6880-3770

Korea - Daegu
Tel: 82-53-744-4301

Korea - Seoul
Tel: 82-2-554-7200

Malaysia - Kuala Lumpur
Tel: 60-3-7651-7906

Malaysia - Penang
Tel: 60-4-227-8870

Philippines - Manila
Tel: 63-2-634-9065

Singapore
Tel: 65-6334-8870

Taiwan - Hsin Chu
Tel: 886-3-577-8366

Taiwan - Kaohsiung
Tel: 886-7-213-7830

Taiwan - Taipei
Tel: 886-2-2508-8600

Thailand - Bangkok
Tel: 66-2-694-1351

Vietnam - Ho Chi Minh
Tel: 84-28-5448-2100

EUROPE

Austria - Wels
Tel: 43-7242-2244-39
Fax: 43-7242-2244-393

Denmark - Copenhagen
Tel: 45-4485-5910
Fax: 45-4485-2829

Finland - Espoo
Tel: 358-9-4520-820

France - Paris
Tel: 33-1-69-53-63-20
Fax: 33-1-69-30-90-79

Germany - Garching
Tel: 49-8931-9700

Germany - Haan
Tel: 49-2129-3766400

Germany - Heilbronn
Tel: 49-7131-72400

Germany - Karlsruhe
Tel: 49-721-625370

Germany - Munich
Tel: 49-89-627-144-0
Fax: 49-89-627-144-44

Germany - Rosenheim
Tel: 49-8031-354-560

Israel - Ra'anana
Tel: 972-9-744-7705

Italy - Milan
Tel: 39-0331-742611
Fax: 39-0331-466781

Italy - Padova
Tel: 39-049-7625286

Netherlands - Drunen
Tel: 31-416-690399
Fax: 31-416-690340

Norway - Trondheim
Tel: 47-7288-4388

Poland - Warsaw
Tel: 48-22-3325737

Romania - Bucharest
Tel: 40-21-407-87-50

Spain - Madrid
Tel: 34-91-708-08-90
Fax: 34-91-708-08-91

Sweden - Gothenberg
Tel: 46-31-704-60-40

Sweden - Stockholm
Tel: 46-8-5090-4654

UK - Wokingham
Tel: 44-118-921-5800
Fax: 44-118-921-5820

X-ON Electronics

Largest Supplier of Electrical and Electronic Components

Click to view similar products for [16-bit Microcontrollers - MCU category](#):

Click to view products by [Microchip manufacturer](#):

Other Similar products are found below :

[M30302FCPP#U3](#) [MB96F683RBPMC-GSAE1](#) [R5F117BCGNA#20](#) [R4F24268NVRFQV](#) [R5F21172DSP#U0](#) [MB90F345CAPFR-GSE1](#)
[MB90F568PMCR-GE1](#) [MB96F387RSBPMC-GS-N2E2](#) [DF2134BFA20V](#) [UPD78F1018F1-BA4-A](#) [MB96F018RBPMC-GSE1](#)
[MB90F867ASPFR-GE1](#) [M30290FCHP#U3A](#) [DF2239FA20IV](#) [LC88F58B0AU-SQFPH](#) [MB90F455SPMCR-G-JNE1](#) [MB90F548GPF-GE1](#)
[S912ZVH128F2VLL](#) [UPD78F1500AGK-GAK-AX](#) [MB90F428GCPF-GSE1](#) [MB90F395HAPMCR-GS-SPE2](#) [MB90F342ESPMC-G-JNE1](#)
[MB96F386RSBPMC-GS-JAE2](#) [MB96F395RWAPMC-GSE2](#) [CY90F497GPMC-GE1](#) [MB96F693RBPMC-GSE1](#) [ST10F280](#)
[MB96F338RSAPMCR-GK5E2](#) [R5F21356CNFP#50](#) [CY90096PF-G-002-BND-ERE1](#) [ML62Q1729-NNNGAZ0AX](#) [ML62Q1333-](#)
[NNNTDZ0ATL](#) [R5F21104DFP#U0](#) [R5F21332CNFP#30](#) [R5F10WLCAFB#30](#) [R5F10WLCAFB#50](#) [R5F10JBCGFP#V0](#) [R5F111MGGFB#30](#)
[R5F104LEAFB#10](#) [R5F10RF8AFP#10](#) [R5F104MGGFB#10](#) [R5F104MHAF#10](#) [R5F10KBCGFP#V0](#) [R5F10269ASP#35](#)
[R5F104GAAFB#10](#) [R5F104LFAFB#10](#) [R5F10WMGGFB#10](#) [R5F100FEAFP#50](#) [R5F10266GSP#35](#) [R5F11BBCGFP#30](#)