

## Low Power, 1.62V to 3.63V, 10MHz to 40MHz, 1:6 Oscillator Fanout Buffer

### FEATURES

- Advanced Oscillator Design for Wide Frequency Coverage
- 6 LVCMOS Outputs with 2 Output Enable Pins
- 8mA Output Drive Strength
- Input/Output Frequency:
  - Fundamental Crystal: 10MHz to 40MHz
- Very Low Jitter and Phase Noise
- Low Current Consumption
- Single 1.62V to 3.63V Power Supply
- Available in QFN-16L and TSSOP-16L GREEN/RoHS Compliant Packages

### DESCRIPTION

The PL135-67 is an advanced oscillator fanout buffer design for high performance, low-power, small form-factor applications. The PL135-67 accepts a fundamental input crystal of 10MHz to 40MHz and produces six outputs of the same frequency, two with their own Output Enable functions.

Offered in a small 3 x 3mm QFN or TSSOP package, the PL135-67 offers the best phase noise and jitter performance and lowest power consumption of any comparable IC.

### PACKAGE PIN CONFIGURATION

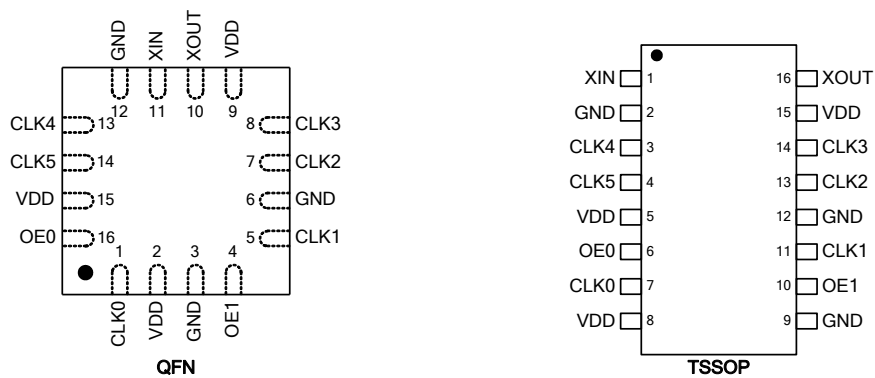

### BLOCK DIAGRAM

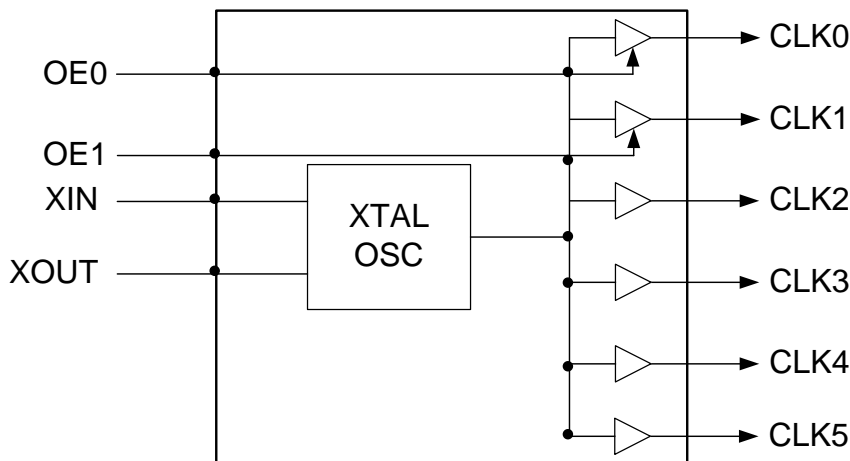

---



---

**Low Power, 1.62V to 3.63V, 10MHz to 40MHz, 1:6 Oscillator Fanout Buffer**

---

**PACKAGE PIN ASSIGNMENT**

Name	Package Pin #		Type	Description
	QFN-16L	(T)SSOP-16L		
CLK0	1	7	O	Output clock
VDD	2, 9, 15	5, 8, 15	P	V <sub>DD</sub> connection
GND	3, 6, 12	2, 9, 12	P	GND connection
OE1	4	6	I*	Output enable (OE) input for CLK1. Internal pull-up. Pull low to tri-state CLK1.
CLK1	5	11	O	Output clock
CLK2	7	13	O	Output clock
CLK3	8	14	O	Output clock
XOUT	10	16	O	Crystal output. Do not connect when using reference clock.
XIN	11	1	I	Crystal input
CLK4	13	3	O	Output clock
CLK5	14	4	O	Output clock
OE0	14	4	I*	Output enable (OE) input for CLK0. Internal pull-up. Pull low to tri-state CLK0.

\* **Note:** These pins include an internal 60kΩ pull up.

## Low Power, 1.62V to 3.63V, 10MHz to 40MHz, 1:6 Oscillator Fanout Buffer

### LAYOUT RECOMMENDATIONS

The following guidelines are to assist you with a performance optimized PCB design:

#### Signal Integrity and Termination Considerations

- Keep traces short!
- Trace = Inductor. With a capacitive load this equals ringing!
- Long trace = Transmission Line. Without proper termination this will cause reflections (looks like ringing).
- Design long traces as “striplines” or “microstrips” with defined impedance.
- Match trace at one side to avoid reflections bouncing back and forth.

#### Decoupling and Power Supply Considerations

- Place decoupling capacitors as close as possible to the  $V_{DD}$  pin(s) to limit noise from the power supply
- Multiple  $V_{DD}$  pins should be decoupled separately for best performance.
- Addition of a ferrite bead in series with  $V_{DD}$  can help prevent noise from other board sources
- Value of decoupling capacitor is frequency dependant. Typical value to use is  $0.1\mu F$ .

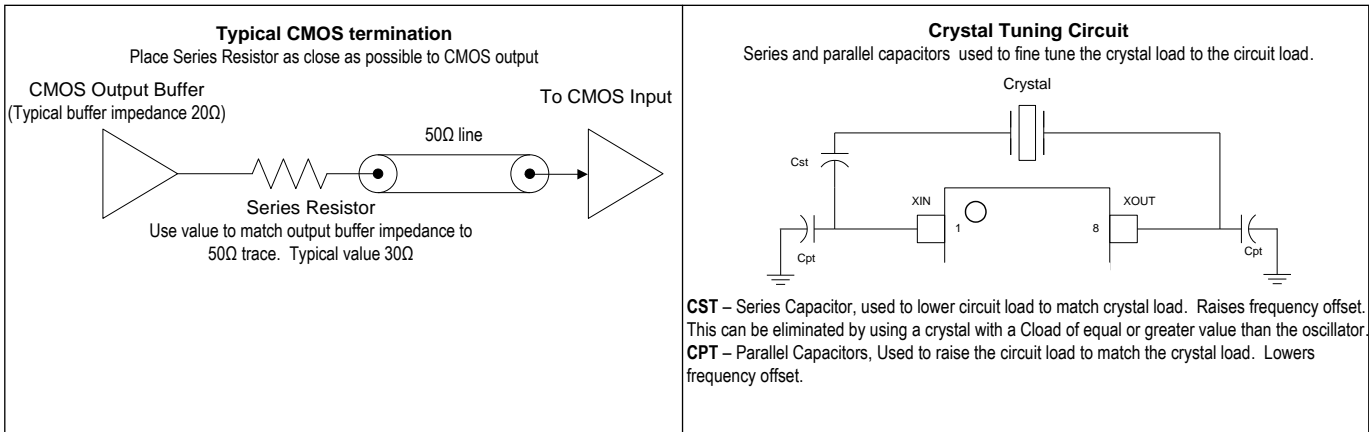

### ELECTRICAL SPECIFICATIONS

#### ABSOLUTE MAXIMUM RATINGS

PARAMETERS	SYMBOL	MIN.	MAX.	UNITS
Supply Voltage Range	$V_{DD}$	-0.5	4.6	V
Input Voltage Range	$V_I$	-0.5	$V_{DD}+0.5$	V
Output Voltage Range	$V_O$	-0.5	$V_{DD}+0.5$	V
Storage Temperature	$T_S$	-65	150	°C
Ambient Operating Temperature*		-40	85	°C

Exposure of the device under conditions beyond the limits specified by Maximum Ratings for extended periods may cause permanent damage to the device and affect product reliability. These conditions represent a stress rating only, and functional operations of the device at these or any other conditions above the operational limits noted in this specification is not implied. \*Operating temperature is guaranteed by design. Parts are tested to commercial grade only.

---



---

**Low Power, 1.62V to 3.63V, 10MHz to 40MHz, 1:6 Oscillator Fanout Buffer**

---



---

**AC SPECIFICATIONS**

PARAMETERS	CONDITIONS	MIN.	TYP.	MAX.	UNITS
Crystal Input Frequency	Fundamental Crystal	10		40	MHz
Settling Time	At power-up ( $V_{DD} \geq 1.62V$ )			2	ms
Output Enable Time	OE Function; $T_a=25^\circ C$ , 10pF Load			10	ns
$V_{DD}$ Sensitivity	Frequency vs. $V_{DD}$ , $\pm 10\%$	-2		2	ppm
Output Rise Time	15pF Load, 10/90% $V_{DD}$ , 3.3V		2	4	ns
Output Fall Time	15pF Load, 90/10% $V_{DD}$ , 3.3V		2	4	ns
Output to Output Skew	Under all conditions			1	ns
Duty Cycle	Under all conditions	45	50	55	%

**DC SPECIFICATIONS**

PARAMETERS	SYMBOL	CONDITIONS	MIN	TYP	MAX	UNITS
Supply Current, Dynamic	$I_{DD}$	$V_{DD} = 3.3V$ , 25MHz, No Load		7.1		mA
		$V_{DD} = 2.5V$ , 25MHz, No Load		4.8		mA
		$V_{DD} = 1.8V$ , 25MHz, No Load		3.4		mA
Operating Voltage	$V_{DD}$		1.62		3.63	V
Output Low Voltage	$V_{OL}$	$I_{OL} = +4mA$ , 3.3V			0.4	V
Output High Voltage	$V_{OH}$	$I_{OH} = -4mA$ , 3.3V	2.4			V
Output Current	$I_{OSD}$	$V_{OL} = 0.4V$ , $V_{OH} = 2.4V$	8			mA

**CRYSTAL SPECIFICATIONS**

PARAMETERS		SYMBOL	MIN.	TYP.	MAX.	UNITS
Fundamental Crystal Resonator Frequency		$F_{XIN}$	10		40	MHz
Crystal Loading Rating		$C_{L(xtal)}$		15		pF
Operating Drive Level				0.1	2	mW
Metal Can Crystal	Shunt Capacitance	$C_0$			5.5	pF
	ESR Max	ESR			40	$\Omega$
Small SMD Crystal	Shunt Capacitance	$C_0$			2.5	pF
	ESR Max	ESR			60	$\Omega$

## Low Power, 1.62V to 3.63V, 10MHz to 40MHz, 1:6 Oscillator Fanout Buffer

### PACKAGE DRAWINGS (GREEN PACKAGE COMPLIANT)

#### QFN 16L

Symbol	Dimension in MM	
	Min.	Max.
A	0.07	0.8
A1	0.05	0.05
A3	0.20	
b	0.18	0.30
D	3.00 BSC	
E	3.00 BSC	
D1	--	1.70
E1	--	1.70
L	0.30	0.50
e	0.50 BSC	

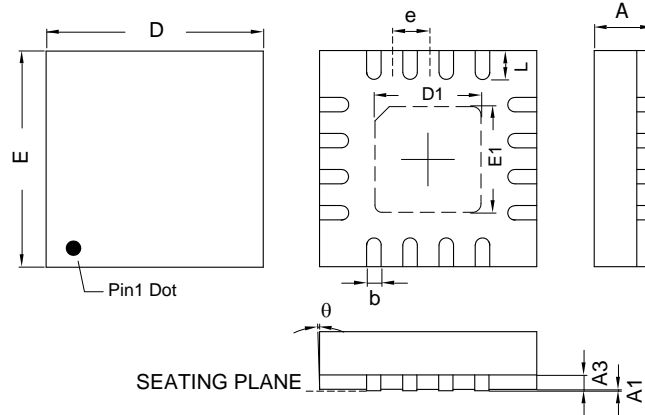

#### TSSOP 16L

Symbol	Dimension in MM	
	Min.	Max.
A	-	1.20
A1	0.05	0.15
b	0.19	0.30
C	0.09	0.20
D	4.90	5.10
E	4.30	4.50
H	6.20	6.60
L	0.45	0.75
e	0.635 BSC	

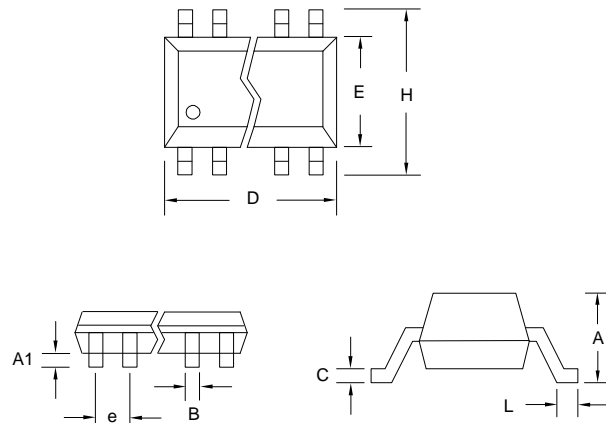

## Low Power, 1.62V to 3.63V, 10MHz to 40MHz, 1:6 Oscillator Fanout Buffer

### ORDERING INFORMATION (GREEN PACKAGE COMPLIANT)

*For part ordering, please contact our Sales Department:*

2180 Fortune Drive, San Jose, CA 95131, USA

Tel: (408) 944-0800 Fax: (408) 474-1000

#### PART NUMBER

The order number for this device is a combination of the following:  
Part number, Package type and Operating temperature range

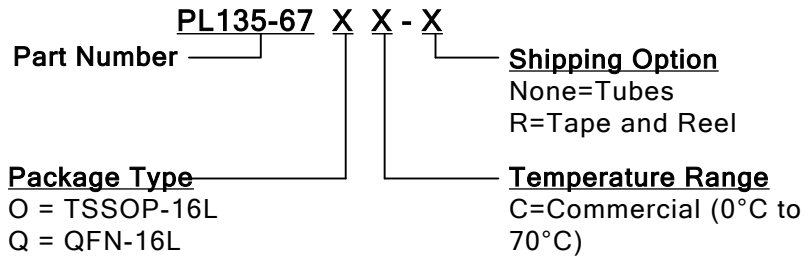

Part Number/Order Number	Marking	Package Option
PL135-67OC	P135-67 OC	16-Pin TSSOP (Tube)
PL135-67OC-R	LLLLL	16-Pin TSSOP (Tape and Reel)
PL135-67QC-R	P135 67 LLL	16-Pin QFN (Tape and Reel)

\*Note: LLL designates lot number

Micrel Inc., reserves the right to make changes in its products or specifications, or both at any time without notice. The information furnished by Micrel is believed to be accurate and reliable. However, Micrel makes no guarantee or warranty concerning the accuracy of said information and shall not be responsible for any loss or damage of whatever nature resulting from the use of, or reliance upon this product.

**LIFE SUPPORT POLICY:** Micrel's products are not authorized for use as critical components in life support devices or systems without the express written approval of the President of Micrel Inc.

## X-ON Electronics

Largest Supplier of Electrical and Electronic Components

*Click to view similar products for [Clock Buffer](#) category:*

*Click to view products by [Microchip](#) manufacturer:*

Other Similar products are found below :

[MPC962309EJ-1H](#) [NB4N121KMNG](#) [IDT49FCT805ASO](#) [MK2308S-1HILF](#) [PL133-27GI-R](#) [NB3L02FCT2G](#) [NB3L03FCT2G](#)  
[ZL40203LDG1](#) [ZL40200LDG1](#) [ZL40205LDG1](#) [9FG1200DF-1LF](#) [9FG1001BGLF](#) [ZL40202LDG1](#) [PI49FCT20802QE](#) [SL2305SC-1T](#)  
[NB7L1008MNG](#) [NB7L14MN1G](#) [PI49FCT20807QE](#) [PI6C4931502-04LIEX](#) [ZL80002QAB1](#) [PI6C4931504-04LIEX](#) [PI6C10806BLEX](#)  
[ZL40226LDG1](#) [8T73S208B-01NLGI](#) [SY75578LMG](#) [PI49FCT32805QEX](#) [PL133-27GC-R](#) [CDCV304PWG4](#) [MC10LVEP11DG](#)  
[MC10EP11DTG](#) [MC100LVEP11DG](#) [MC100E111FNG](#) [MC100EP11DTG](#) [NB6N11SMNG](#) [NB7L14MMNG](#) [NB6L11MMNG](#)  
[NB6L14MMNR2G](#) [NB6L611MNG](#) [PL123-02NGI-R](#) [NB3N111KMNR4G](#) [ADCLK944BCPZ-R7](#) [ZL40217LDG1](#) [NB7LQ572MNG](#)  
[HMC940LC4BTR](#) [ADCLK946BCPZ-REEL7](#) [ADCLK946BCPZ](#) [ADCLK854BCPZ](#) [ADCLK905BCPZ-R2](#) [ADCLK905BCPZ-R7](#)  
[ADCLK905BCPZ-WP](#)