

# PL602041



## ClockWorks™ PCIe Quad Outputs Ultra-Low Jitter, HCSL Frequency Synthesizer

### General Description

The PL602041 is a member of the ClockWorks™ family of devices from Micrel and provides an extremely low-noise timing solution for PCI Express clock signals.

The device operates from a 3.3V or 2.5V power supply and synthesizes four HCSL output clocks at 25MHz, 100MHz, 125MHz, and 200MHz. The PL602041 accepts a 25MHz crystal.

Datasheets and support documentation are available on Micrel's web site at: [www.micrel.com](http://www.micrel.com).

### Features

- Input crystal frequency of 25MHz
- Generates four HCSL clock outputs at 25MHz, 100MHz, 125MHz, and 200MHz
- 2.5V or 3.3V operating range
- Typical phase jitter @ 100MHz (1.875MHz to 20MHz): 105fs
- Compliant with PCI Express Gen1, Gen2, and Gen3
- Industrial temperature range (–40°C to +85°C)
- RoHS and PFOS compliant
- Available in 24-pin 4mm x 4mm QFN package

### Applications

- Servers
- Storage systems
- Switches and routers
- Gigabit Ethernet
- Set-top boxes/DVRs

### Block Diagram

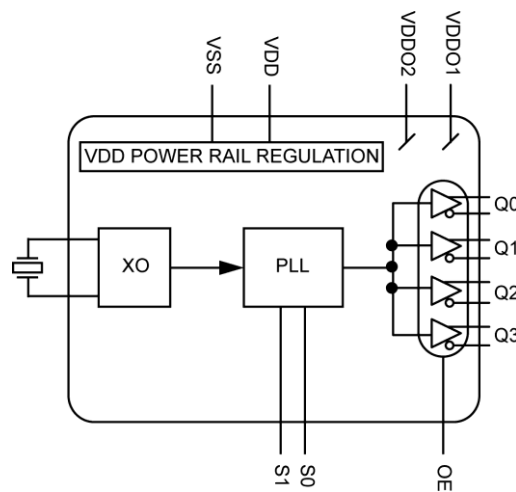

ClockWorks and Ripple Blocker are trademarks of Micrel, Inc.

Micrel Inc. • 2180 Fortune Drive • San Jose, CA 95131 • USA • tel +1 (408) 944-0800 • fax + 1 (408) 474-1000 • <http://www.micrel.com>

January 28, 2014

Revision 1.3  
[tcghelp@micrel.com](mailto:tcghelp@micrel.com) or (408) 955-1690

## Ordering Information<sup>(1)</sup>

Part Number	Marking	Shipping	Junction Temperature Range	Package	Lead Finish
PL602041UMG	PL602 041	Tube	-40°C to +85°C	24-Pin QFN	NiPdAu
PL602041UMG TR	PL602 041	Tape and Reel	-40°C to +85°C	24-Pin QFN	NiPdAu

**Note:**

1. Devices are RoHS and PFOS compliant.

## Pin Configuration

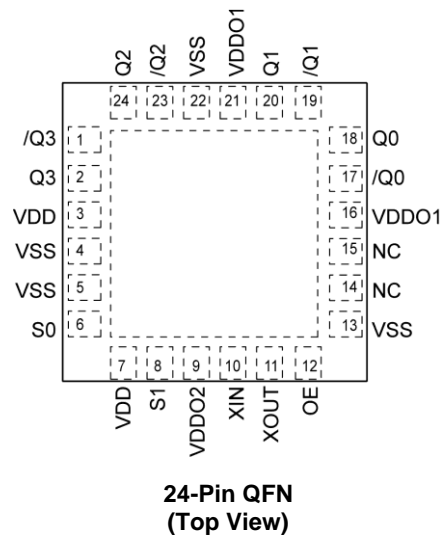

## Pin Description

Pin Number	Pin Name	Pin Type	Pin Level	Pin Function
17, 18 19, 20	/Q0, Q0 /Q1, Q1	O, (DIF)	HCSL	Differential Clock Outputs Pairs.
23, 24 1, 2	/Q2, Q2 /Q3, Q3	O, (DIF)	HCSL	Differential Clock Outputs Pairs.
9	VDDO2	PWR		Power Supply.
16, 21	VDDO1	PWR		Power Supply.
3, 7	VDD	PWR		Core Power Supply.
4, 5, 13, 22	VSS	PWR		Power Supply Ground.
6, 8	S0, S1	I	LVC MOS	Frequency Select for 25MHz, 100MHz, 125MHz, and 200MHz. Each pin has a 45KΩ pull-up.
10	XIN	I, (SE)	Crystal	Crystal Input, no load caps needed (see <a href="#">Figure 5</a> ).
11	XOUT	O, (SE)	Crystal	Crystal Output, no load caps needed (see <a href="#">Figure 5</a> ).
12	OE	I, (SE)	LVC MOS	Output Enable/Disable.
14, 15	NC			No Connect.

**Absolute Maximum Ratings<sup>(2)</sup>**

Supply Voltage ( $V_{DD}$ , $V_{DDO1/2}$ )	+4.6V
Input Voltage ( $V_{IN}$ )	-0.50V to $V_{DD} + 0.5V$
Lead Temperature (soldering, 20s)	260°C
Case Temperature	115°C
Storage Temperature ( $T_S$ )	-65°C to +150°C

**Operating Ratings<sup>(3)</sup>**

Supply Voltage ( $V_{DD}$ , $V_{DDO1/2}$ )	+2.375V to +3.465V
Ambient Temperature ( $T_A$ )	-40°C to +85°C
Junction Thermal Resistance <sup>(4)</sup>	
QFN ( $\theta_{JA}$ ) Still Air	50°C/W
QFN ( $\psi_{JB}$ ) Junction-to-Board	30°C/W

**DC Electrical Characteristics<sup>(5)</sup>**

$V_{DD} = V_{DDO1/2} = 3.3V \pm 5\%$  or  $2.5V \pm 5\%$

$V_{DD} = 3.3V \pm 5\%$ ,  $V_{DDO1/2} = 3.3V \pm 5\%$  or  $2.5V \pm 5\%$

$T_A = -40^\circ\text{C}$  to  $+85^\circ\text{C}$ .

Symbol	Parameter	Condition	Min.	Typ.	Max.	Units
$V_{DD}$ , $V_{DDO1/2}$	2.5V Operating Voltage		2.375	2.5	2.625	V
$V_{DD}$ , $V_{DDO1/2}$	2.5V Operating Voltage		3.135	3.3	3.465	V
$I_{DD}$	Supply Current to $V_{DD} + V_{DDO}$	Outputs 50Ω to $V_{SS}$		150	185	mA

**HCSL DC Electrical Characteristics<sup>(5)</sup>**

$V_{DD} = V_{DDO1/2} = 3.3V \pm 5\%$  or  $2.5V \pm 5\%$

$V_{DD} = 3.3V \pm 5\%$ ,  $V_{DDO1/2} = 3.3V \pm 5\%$  or  $2.5V \pm 5\%$

$T_A = -40^\circ\text{C}$  to  $+85^\circ\text{C}$ .  $R_L = 50\Omega$  to  $V_{SS}$

Symbol	Parameter	Condition	Min.	Typ.	Max.	Units
$V_{OH}$	Output High Voltage		660	700	850	mV
$V_{OL}$	Output Low Voltage		-150	0	27	mV
$V_{CROSS}$	Crossing Point Voltage		250	350	550	mV

**LVC MOS (S0, S1) DC Electrical Characteristics<sup>(6)</sup>**

$V_{DD} = 3.3V \pm 5\%$ , or  $2.5V \pm 5\%$ ,  $T_A = -40^\circ\text{C}$  to  $+85^\circ\text{C}$ .

Symbol	Parameter	Condition	Min.	Typ.	Max.	Units
$V_{IH}$	Input High Voltage		2		$V_{DD} + 0.3$	V
$V_{IL}$	Input Low Voltage		-0.3		0.8	V
$I_{IH}$	Input High Current	$V_{DD} = V_{IN} = 3.465V$			150	μA
$I_{IL}$	Input Low Current	$V_{DD} = 3.465V$ , $V_{IN} = 0V$	-150			μA

**Notes:**

- Permanent device damage may occur if absolute maximum ratings are exceeded. This is a stress rating only and functional operation is not implied at conditions other than those detailed in the operational sections of this data sheet. Exposure to absolute maximum rating conditions for extended periods may affect device reliability.
- The datasheet limits are not guaranteed if the device is operated beyond operating ratings.
- Package thermal resistance assumes exposed pad is soldered (or equivalent) to the device's most negative potential on the PCB.
- The circuit is designed to meet the AC and DC specifications shown in the above table(s) after thermal equilibrium has been established.
- All phase noise measurements were taken with an Agilent 5052B phase noise system.

## Crystal Characteristics

Parameter	Condition	Min.	Typ.	Max.	Units
Mode of Oscillation	10pF load capacitance	Fundamental, Parallel Resonant			
Frequency			25		MHz
Equivalent Series Resistance (ESR)				50	$\Omega$
Shunt Capacitor, C0			1	5	pF
Correlation Drive Level			10	100	$\mu$ W

## AC Electrical Characteristics<sup>(6, 7)</sup>

$$V_{DD} = V_{DDO1/2} = 3.3V \pm 5\% \text{ or } 2.5V \pm 5\%$$

$$V_{DD} = 3.3V \pm 5\%, V_{DDO1/2} = 3.3V \pm 5\% \text{ or } 2.5V \pm 5\%$$

$$T_A = -40^\circ\text{C to } +85^\circ\text{C. } R_L = 50\Omega \text{ to } V_{SS}$$

Symbol	Parameter	Condition	Min.	Typ.	Max.	Units
F <sub>OUT</sub>	Output Frequency			25, 100, 125, 200		MHz
F <sub>REF</sub>	Crystal Input Frequency			25		MHz
T <sub>R</sub> /T <sub>F</sub>	HCSL Output Rise/Fall Time	20% – 80%	150	300	450	ps
ODC	Output Duty Cycle		48	50	52	%
T <sub>SKEW</sub>	Output-to-Output Skew	Note 7			45	ps
T <sub>LOCK</sub>	PLL Lock Time				20	ms
T <sub>JIT</sub> ( $\emptyset$ )	RMS Phase Jitter <sup>(8)</sup>	100MHz Integration Range (1.875MHz–20MHz) Integration Range (12kHz–20MHz)		105 250		fs

### Notes:

7. Defined as skew between outputs at the same supply voltage and with equal load conditions; measured at the output differential crossing points.
8. Measured using 25MHz crystal as the input reference source. If using an external reference input, use a low phase noise source. With an external reference, the phase noise will follow the input source phase noise up to about 1MHz.

## Truth Tables

S1	S0	OUTPUT
0	0	25MHz
0	1	100MHz
1	0	125MHz
1	1	200MHz

# Phase Noise Plots

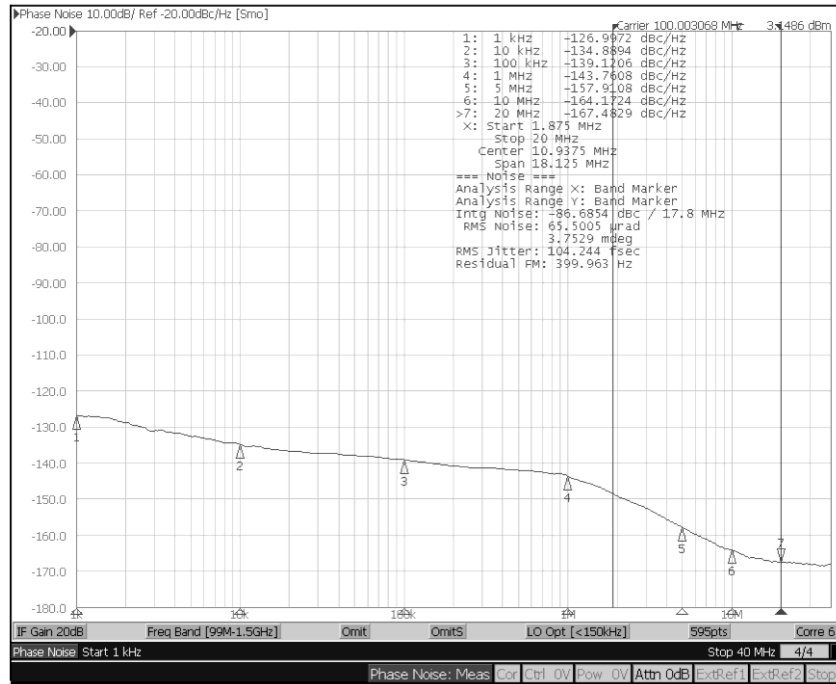

Phase Noise Plot: 100MHz, 1.875MHz–20MHz 104fs

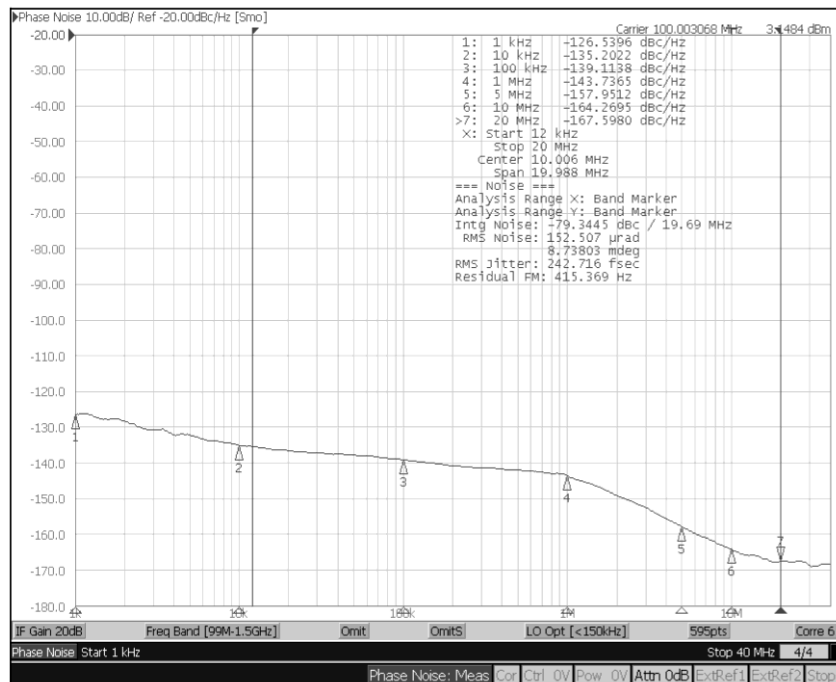

Phase Noise Plot: 100MHz, 12kHz–20MHz 242fs

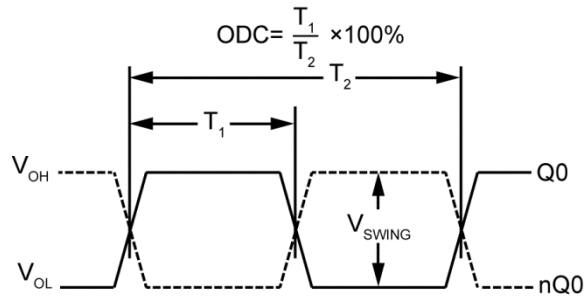

Figure 1. Duty Cycle Timing

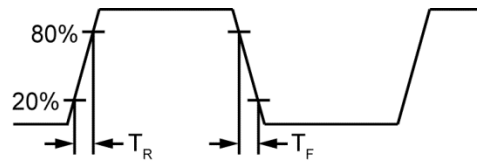
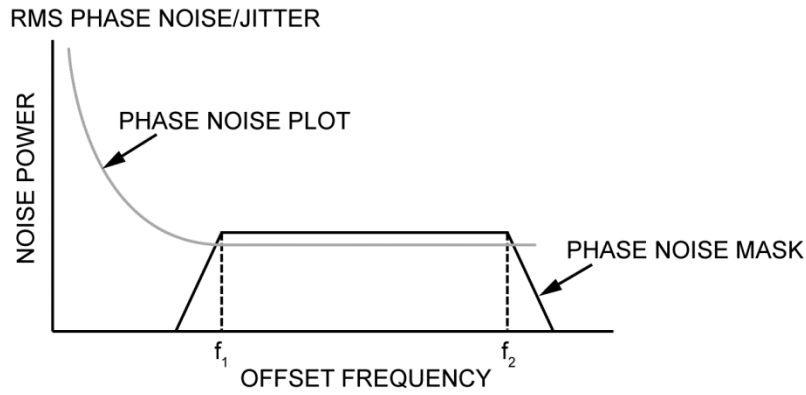

Figure 2. All Outputs Rise/Fall Time



$RMS\ JITTER = \sqrt{\text{AREA UNDER THE MASKED PHASE NOISE PLOT}}$

Figure 3. RMS Phase/Noise Jitter

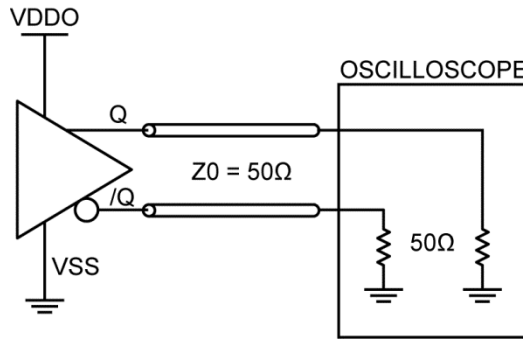

Figure 4. HCSL Output Load and Test Circuit

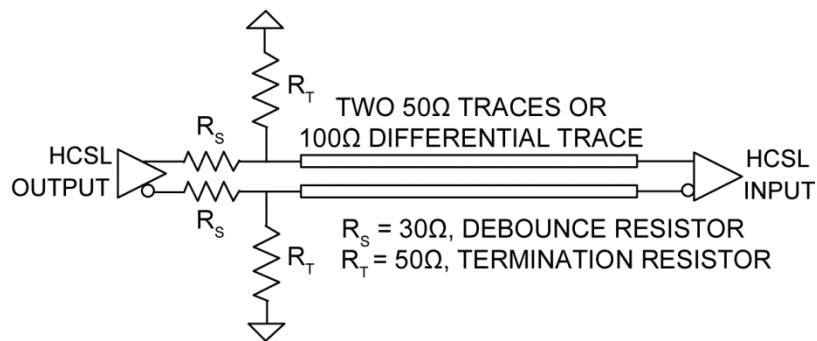

Figure 5. HCSL Recommended Application Termination (Source Terminated)

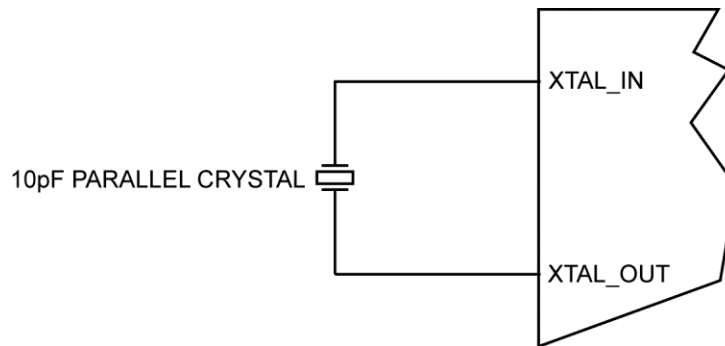

Figure 6. Crystal Input Interface

## Application Information

### Crystal Layout

Keep the layers under the crystal as open as possible and do not place switching signals or noisy supplies under the crystal. Crystal load capacitance is built inside the die, so no external capacitance is needed. See the *Selecting a Quartz Crystal for the Clockworks Flex I Family of Precision Synthesizers* application note for more details.

Contact Micrel's HBW applications group at: [tcghelp@micrel.com](mailto:tcghelp@micrel.com) if you need help selecting a suitable crystal for your application.

### Power Supply and Decoupling

Place the smallest value decoupling capacitor (4.7nF above) between the VDD and VSS pins, as close as possible to those pins and at the same side of the PCB as the IC. The shorter the physical path from VDD to capacitor and back from capacitor to VSS, the more effective the decoupling. Use one 4.7nF capacitor for each VDD pin on the PL602041.

The impedance value of the Ferrite Bead (FB) needs to be between 240Ω and 600Ω with a saturation current ≥150mA.

VDDO1 and VDDO2 pins connect directly to the VDD plane. All VDD pins on the PL602041 connect to VDD after the power supply filter.

### HCSL Outputs

HCSL outputs are to be terminated with 50Ω to VSS. For best performance load all outputs. If you want to AC-couple or change the termination, contact Micrel's application group: [tcghelp@micrel.com](mailto:tcghelp@micrel.com) (see Figure 5).

## Power Supply Filtering Recommendations

Preferred filter, using Micrel MIC94300 or MIC94310 Ripple Blocker™:

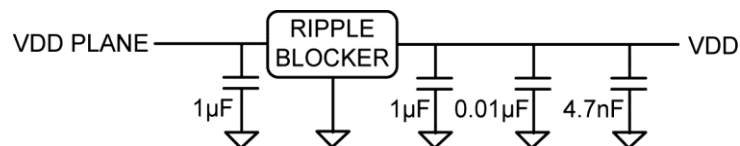

Alternative, traditional filter, using a ferrite bead:

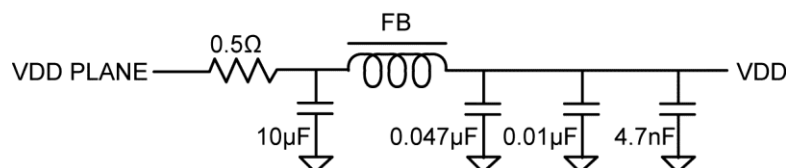



Package Information<sup>(9)</sup>

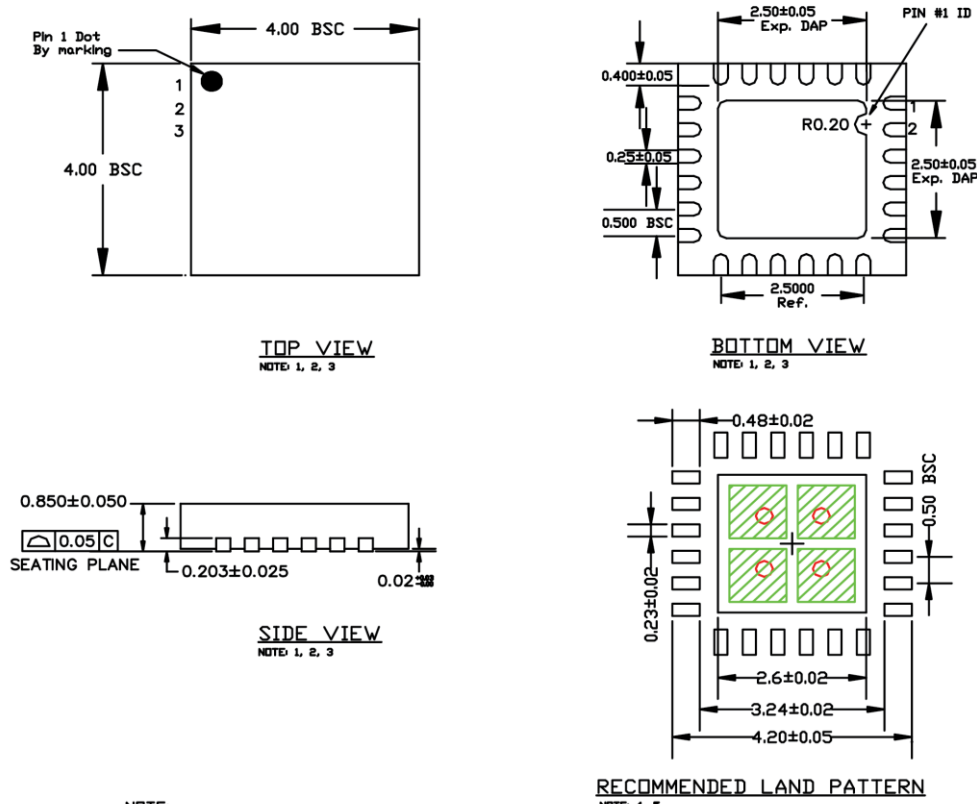

NOTE:  
 1. MAX PACKAGE WARPAGE IS 0.05 MM  
 2. MAX ALLOWABLE BURR IS 0.076MM IN ALL DIRECTIONS  
 3. PIN #1 IS ON TOP WILL BE LASER MARKED  
 4. RED CIRCLE IN LAND PATTERN INDICATE THERMAL VIA. SIZE SHOULD BE 0.30-0.3M IN DIAMETER AND SHOULD BE CONNECTED TO GND FOR MAX THERMAL PERFORMANCE  
 5. GREEN RECTANGLES (SHADED AREA) INDICATE SOLDER STENCIL OPENING ON EXPOSED PAD AREA. SIZE SHOULD BE 1.00x1.00 MM IN SIZE, 1.20 MM PITCH.

24-Pin Package Type (QFN)

Note:

9. Package information is correct as of the publication date. For updates and most current information, go to [www.micrel.com](http://www.micrel.com).

**MICREL, INC. 2180 FORTUNE DRIVE SAN JOSE, CA 95131 USA**  
 TEL +1 (408) 944-0800 FAX +1 (408) 474-1000 WEB <http://www.micrel.com>

Micrel makes no representations or warranties with respect to the accuracy or completeness of the information furnished in this data sheet. This information is not intended as a warranty and Micrel does not assume responsibility for its use. Micrel reserves the right to change circuitry, specifications and descriptions at any time without notice. No license, whether express, implied, arising by estoppel or otherwise, to any intellectual property rights is granted by this document. Except as provided in Micrel's terms and conditions of sale for such products, Micrel assumes no liability whatsoever, and Micrel disclaims any express or implied warranty relating to the sale and/or use of Micrel products including liability or warranties relating to fitness for a particular purpose, merchantability, or infringement of any patent, copyright or other intellectual property right.

Micrel Products are not designed or authorized for use as components in life support appliances, devices or systems where malfunction of a product can reasonably be expected to result in personal injury. Life support devices or systems are devices or systems that (a) are intended for surgical implant into the body or (b) support or sustain life, and whose failure to perform can be reasonably expected to result in a significant injury to the user. A Purchaser's use or sale of Micrel Products for use in life support appliances, devices or systems is a Purchaser's own risk and Purchaser agrees to fully indemnify Micrel for any damages resulting from such use or sale.

© 2014 Micrel, Incorporated.

## X-ON Electronics

Largest Supplier of Electrical and Electronic Components

*Click to view similar products for [Clock Generators & Support Products](#) category:*

*Click to view products by [Microchip](#) manufacturer:*

Other Similar products are found below :

[CV183-2TPAG](#) [950810CGLF](#) [9DBV0741AKILF](#) [9VRS4420DKLF](#) [CY25404ZXI226](#) [CY25422SXI-004](#) [MPC9893AE](#) [NB3H5150-01MNTXG](#) [PL602-20-K52TC](#) [PI6LC48P0101LIE](#) [82P33814ANLG](#) [840021AGLF](#) [ZL30244LFG7](#) [PI6LC48C21LE](#) [ZL30245LFG7](#) [PI6LC48P0405LIE](#) [PI6LC48P03LE](#) [MAX24505EXG+](#) [ZL30163GDG2](#) [5L1503L-000NVTG8](#) [MAX24188ETK2](#) [ZL30152GGG2](#) [5L1503-000NVTG8](#) [PI6C557-01BZHIEX](#) [PI6LC48C21LIE](#) [PI6C557-03AQEX](#) [5P35023-106NLGI](#) [5X1503L-000NLGI8](#) [ZL30121GGG2V2](#) [ZL30282LDG1](#) [ZL30102QDG1](#) [ZL30159GGG2](#) [ZL30145GGG2](#) [ZL30312GKG2](#) [MAX24405EXG2](#) [ZL30237GGG2](#) [SY100EL34LZG](#) [9FGV1002BQ506LTGI](#) [AD9518-4ABCPZ](#) [MX852BB0030](#) [PI6LC4840ZHE](#) [AD9516-0BCPZ-REEL7](#) [AD9574BCPZ-REEL7](#) [PL602-21TC-R](#) [ZL30105QDG1](#) [ZL30100QDG1](#) [ZL30142GGG2](#) [ZL30250LDG1](#) [DSC557-0334FI1](#) [DSC557-0343FI1](#)