

8-Channel OC-3c ATM and POS Physical Layer Device

FEATURES

- Single chip 8-channel ATM and POS User Network Interface operating at 155 Mbit/s with on-chip clock and data recovery and clock synthesis for direct connection to optical modules.
- Implements the ATM Forum User Network Interface Specification and the ATM physical layer for Broadband ISDN according to ITU Recommendation I.432.
- Implements the Point-to-Point Protocol (PPP) over SONET/SDH specification according to RFC 2615(1619)/1662 of the PPP Working Group of the Internet Engineering Task Force (IETF).
- Processes eight bit-serial 155 Mbit/s STS-3c (STM-1) data streams with on-chip clock and data recovery and clock synthesis.
- Complies with Bellcore GR-253-CORE (2000 issue) jitter tolerance, jitter transfer (1995 issue), and intrinsic jitter criteria.
- Each channel provides termination for SONET Section, Line, and Path overhead or SDH Regenerator Section, Multiplexer Section, and High Order Path overhead.
- Provides UTOPIA Level 3 32-bit wide System Interface (clocked up to 104 MHz) with parity support for ATM applications.
- Provides SATURN® POS-PHY™ Level 3 32-bit System Interface (clocked up to 104 MHz) for Packet over SONET (POS), or ATM applications.
- Supports line loopback from the line side receive stream to the transmit stream and diagnostic loopback from the line side transmit stream to the line side receive stream interface.
- Provides support for automatic protection switching including a bi-directional 2-bit PECL 622 MHz port for external APS with mate device.
- Built-in APS cross-connect for internal and external 1+1 and 1:n protection switching.
- Provides a standard five signal IEEE 1149.1 JTAG test port for boundary scan board test purposes.
- Provides a generic 8-bit microprocessor bus interface for configuration, control, and status monitoring.
- Low power 2.5/3.3 V CMOS core logic with 5V TTL compatible digital inputs and digital outputs. PECL inputs and outputs are 3.3 V and 5 V compatible.
- Industrial temperature range (-40 °C to +85 °C).
- 520-pin SBGA package.
- Software compatible with the PM5358 S/UNI 4x622.
- Pin compatible with PM5382 S/UNI 16x155.

DEVICE INTERNETWORKING

Other PMC-Sierra devices that implement the POS-PHY Level 3 interface include:

- S/UNI 12xJET
- S/UNI 4x622
- S/UNI 2488
- S/UNI 2xGE
- S/UNI MACH48
- S/UNI ATLAS 3200
- S/UNI 16x155

APPLICATIONS

- WAN and Edge ATM switches.
- LAN switches and hubs.
- Packet switches and hubs.
- Routers and Layer 3 Switches.
- Network interface cards and uplinks.

BLOCK DIAGRAM

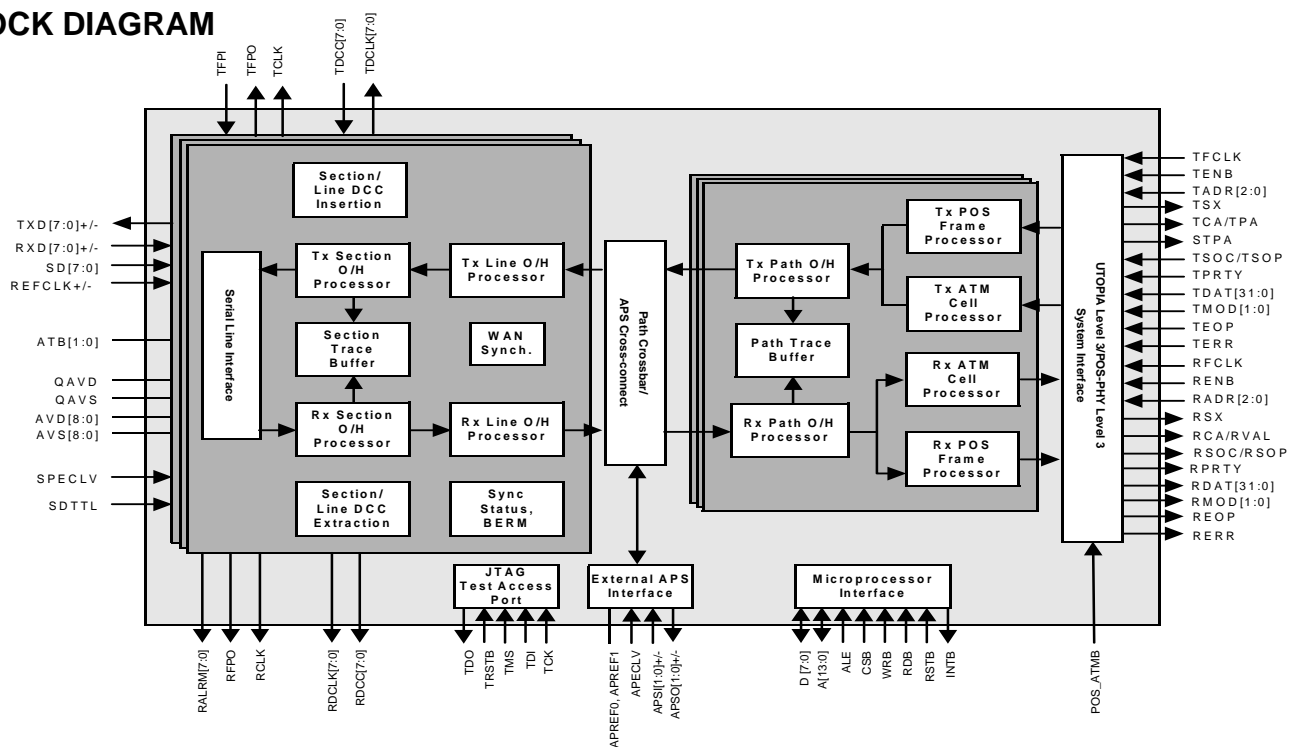

8-Channel OC-3c ATM and POS Physical Layer Device

TYPICAL APPLICATIONS

STS-3C/STM-1 ATM SWITCH PORT

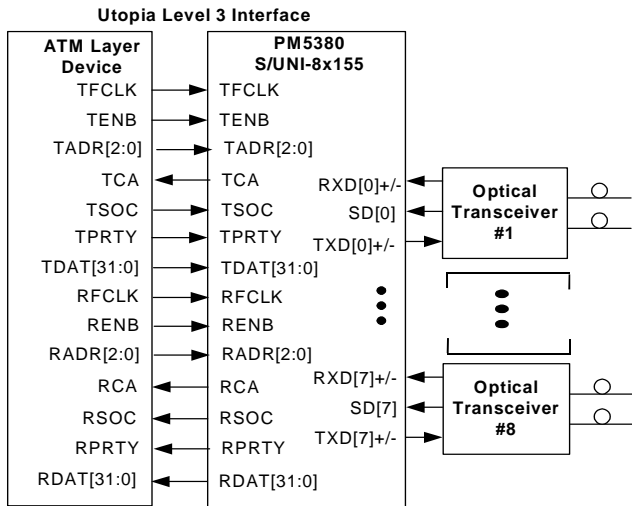

STS-3C/STM-1 PACKET-OVER-SONET/SDH

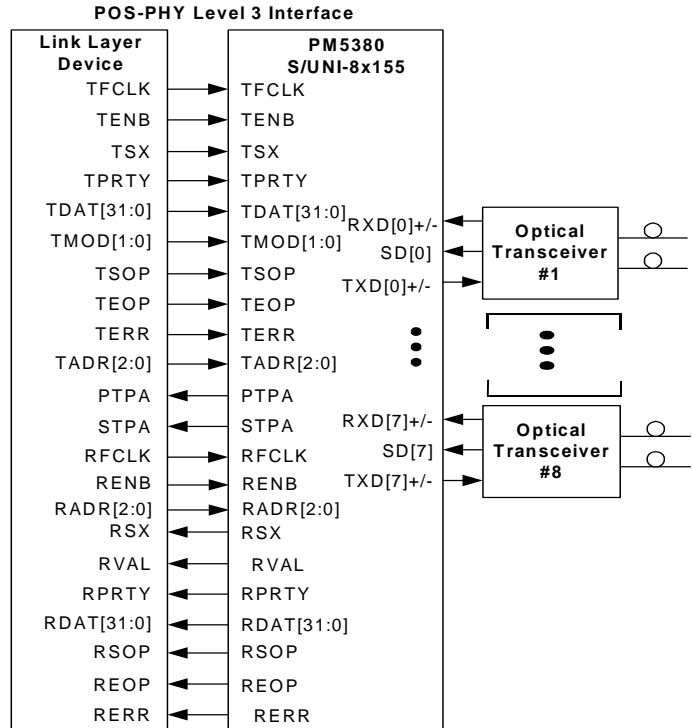

S/UNI-8X155 JITTER TOLERANCE PLOT

Framed Jitter Tolerance (Synchronous, With OA)
under Nominal Condition

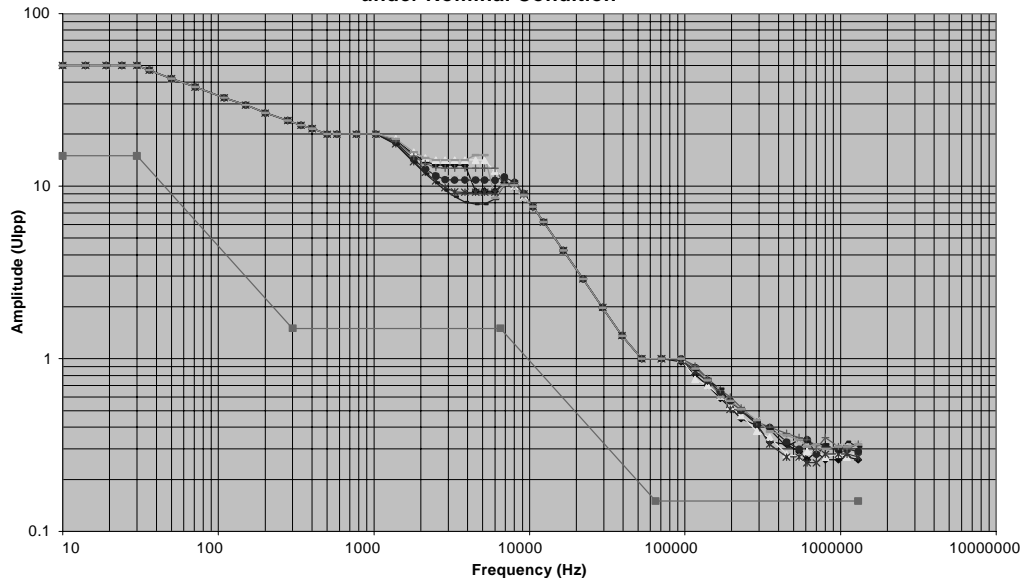

Head Office:
PMC-Sierra, Inc.
8555 Baxter Place
Burnaby, B.C. V5A 4V7
Canada
Tel: +1.604.415.6000
Fax: +1.604.415.6200

To order documentation,
send email to:
document@pmc-sierra.com
or contact the head office,
Attn: Document Coordinator

All product documentation is available
on our web site at:
<http://www.pmc-sierra.com>
For corporate information,
send email to:
info@pmc-sierra.com

PMC-2021288 (R1)
© Copyright PMC-Sierra,
Inc. 2002. All rights reserved.
SATURN and S/UNI are
registered trademarks of
PMC-Sierra, Inc. PMC-
Sierra, PMCS, PMC, and
POS-PHY are trademarks of
PMC-Sierra, Inc.

X-ON Electronics

Largest Supplier of Electrical and Electronic Components

Click to view similar products for [Telecom Interface ICs](#) category:

Click to view products by [Microchip](#) manufacturer:

Other Similar products are found below :

[MT8888CP1](#) [MT88E45BS1](#) [MT9174AN1](#) [MT8870DNR1](#) [MT88E39ASR1](#) [MT9074AL1](#) [MT9122AP1](#) [PEB4266TV12 S LL62](#)
[DS3150TNC1+](#) [DS26334GN+](#) [MT88E46AS1](#) [MT8963AE1](#) [DS26324GNA3+](#) [PM4351-RI](#) [PEF41068FV11 S LL8T](#) [PEF41068VV12 S LL8U](#)
[LE58QL022BVC](#) [LE58QL022BVCT](#) [LE88286DLC](#) [LE88276DLCT](#) [LE79252BTC](#) [RTL8019AS](#) [W7100A-S2E-100LQFP](#) [M100EVO-LITE](#)
[HE910NAR206T701](#) [XRT86VL38IB](#) [CMX631AD4](#) [XD8870](#) [82P2284BBG](#) [82V2084PFG](#) [CPC5620A](#) [CPC5620ATR](#) [CPC5621A](#)
[CPC5621ATR](#) [CPC5622A](#) [CPC5622ATR](#) [DS21455+](#) [DS21348G+](#) [DS2148TN+](#) [DS34S102GN+](#) [DS34T101GN+](#) [CMX673E3](#)
[LE88506DVC](#) [MT88E39AS1](#) [LE89810BSCT](#) [LE89810BSC](#) [CMX673D4](#) [CMX683D4](#) [CMX602BD4](#) [MT8967AS1](#)