

4.9-5.8 GHz High-Linearity Power Amplifier

SST11CP15



Data Sheet

FEATURES:

- **Small Package Size**
- **High Linear Output Power:**
 - 802.11a OFDM Spectrum mask compliance up to 23 dBm
 - Added EVM~2.5% up to 18 dBm, typically, across 5.1-5.8 GHz for 54 Mbps 802.11a signal
- **High Power-added Efficiency/Low Operating Current for 54 Mbps 802.11a Applications**
 - ~11% @ $P_{OUT} = 19$ dBm for 54 Mbps
- **Gain:**
 - Typically 26 dB gain across broadband 4.9-5.8 GHz
- **Low Idle Current**
 - ~120 mA I_{CQ}
- **High Speed Power-up/-down**
 - Turn on/off time (10%~90%) <100 ns
- **Low Shut-down Current (<1 μ A)**
- **On-chip Power Detection**
- **20 dB Dynamic Range On-chip Power Detection**
- **50 Ω On-chip Input Matching and Simple Output Matching**
- **Packages Available**
 - 12-contact UQFN (2mm x 2mm x 0.6mm max thickness)

APPLICATIONS:

- **WLAN (IEEE 802.11a/n)**
- **Japan WLAN**
- **HyperLAN2**
- **Multimedia**

PRODUCT DESCRIPTION

The SST11CP15 is a high-linearity power amplifier that has low power consumption and is based on the highly-reliable InGaP/GaAs HBT technology.

The SST11CP15 can be easily configured for high-linearity, high-efficiency applications with superb power-added efficiency while operating over the entire 802.11a frequency band for U.S., European, and Japanese markets (4.9-5.8 GHz).

The SST11CP15 has excellent linearity, typically ~2.5% added EVM at 18 dBm output power which is essential for 54 Mbps 802.11a operation while meeting 802.11a spectrum mask at 23 dBm. SST11CP15 also has wide-range, single-ended power detectors which lower users' cost on power control.

The power amplifier IC also features easy board-level usage along with high-speed power-up/down control. Low reference current (total $I_{REF} < 5$ mA) makes the SST11CP15 controllable by an on/off switching signal directly from the baseband chip. These features coupled with low operating current make the SST11CP15 ideal for the final stage power amplification in battery-powered 802.11a WLAN transmitter and access point applications.

The SST11CP15 is offered in 12-contact UQFN package with 0.6 mm maximum thickness. See Figure 2 for pin assignments and Table 1 for pin descriptions.



4.9-5.8 GHz High-Linearity Power Amplifier SST11CP15

Data Sheet

FUNCTIONAL BLOCKS

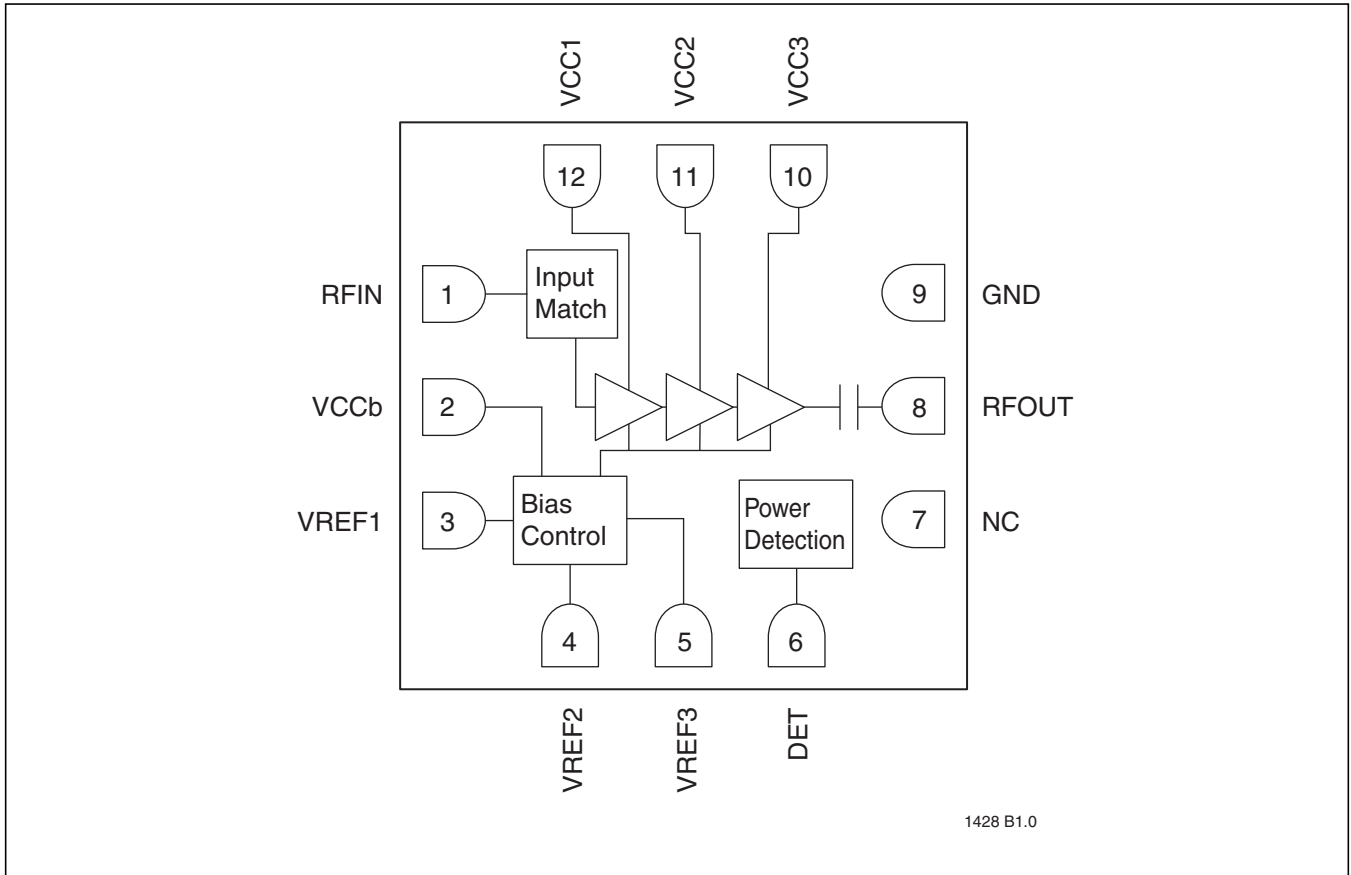

FIGURE 1: Functional Block Diagram

PIN ASSIGNMENTS

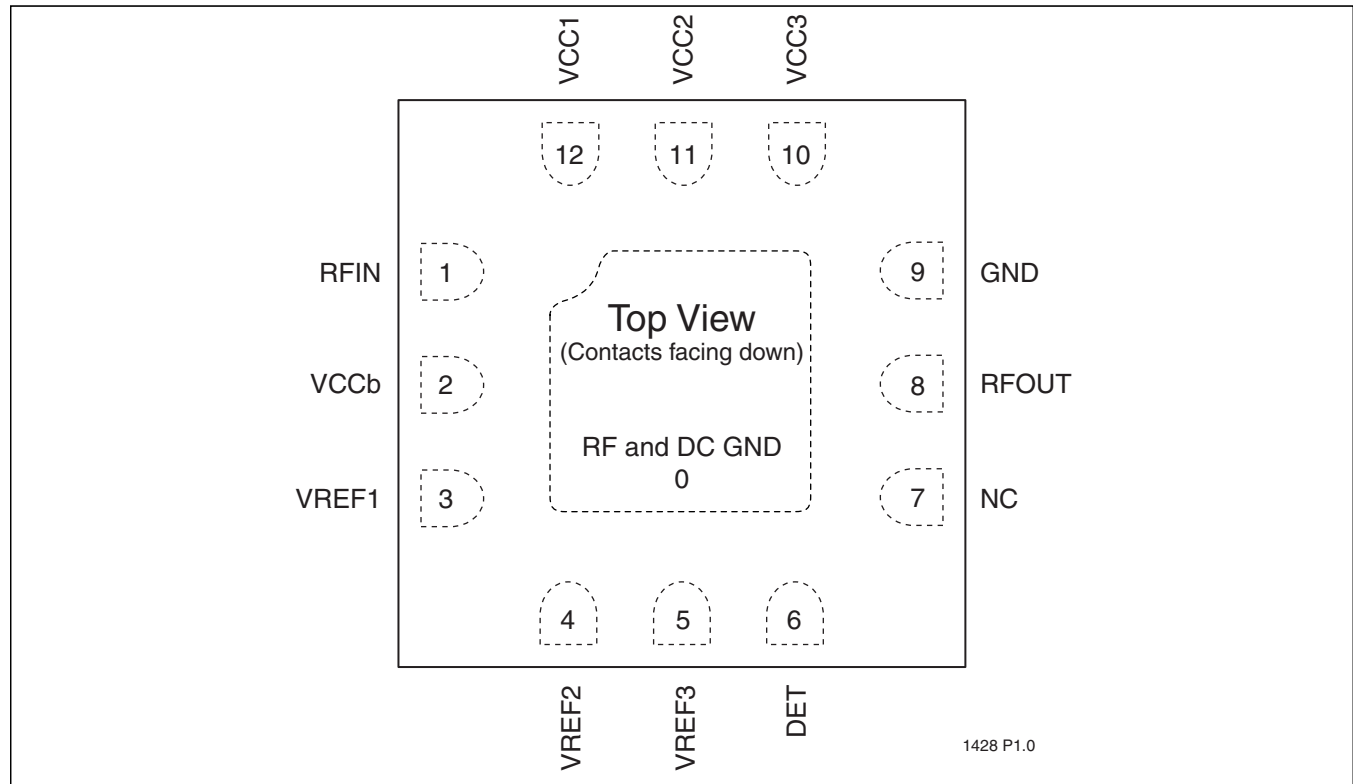

FIGURE 2: Pin Assignments for 12-contact UQFN

PIN DESCRIPTIONS

TABLE 1: Pin Description

Symbol	Pin No.	Pin Name	Type ¹	Function
GND	0	Ground		The center pad should be connected to RF ground with several low inductance, low resistance vias.
RFIN	1		I	RF input, DC decoupled
VCCb	2	Power Supply	PWR	Supply voltage for bias circuit
VREF1	3		PWR	Current Control
VREF2	4		PWR	Current Control
VREF3	5		PWR	Current Control
DET	6		O	On-chip power detector
NC	7	No Connection		Unconnected pin
RFOUT	8		O	RF Output
GND	9	Ground		Ground (NC is acceptable)
VCC3	10	Power Supply	PWR	Power supply, 3 rd stage
VCC2	11	Power Supply	PWR	Power supply, 2 nd stage
VCC1	12	Power Supply	PWR	Power supply, 1 st stage

1. I=Input, O=Output



4.9-5.8 GHz High-Linearity Power Amplifier SST11CP15

Data Sheet

ELECTRICAL SPECIFICATIONS

The AC and DC specifications for the power amplifier interface signals. Refer to Table 2 for the DC voltage and current specifications. Refer to Figures 3 through 8 for the RF performance.

Absolute Maximum Stress Ratings (Applied conditions greater than those listed under “Absolute Maximum Stress Ratings” may cause permanent damage to the device. This is a stress rating only and functional operation of the device at these conditions or conditions greater than those defined in the operational sections of this data sheet is not implied. Exposure to absolute maximum stress rating conditions may affect device reliability.)

Supply Voltage at pins 2, 10, 11, 12 (V_{CC})	-0.3V to +5.5V
DC supply current (I_{CC})	500 mA
Operating Temperature (T_A)	-20°C to +85°C
Storage Temperature (T_{STG})	-40°C to +120°C
Maximum Junction Temperature (T_J)	+150°C
Maximum Output Power	27 dBm
Surface Mount Solder Reflow Temperature	260°C for 10 seconds

OPERATING RANGE

Range	Ambient Temp	V_{CC}
Industrial	-10°C to +85°C	3.3V

TABLE 2: DC Electrical Characteristics

Symbol	Parameter	Min.	Typ	Max.	Unit	Notes
V_{CC}	Supply Voltage at pins 2, 10, 11, 12	2.7	3.3	4.2	V	
I_{CC}	Supply Current @ $P_{OUT} = 18$ dBm at $V_{CC} = 3.3V$		210		mA	
I_{CQ}	V_{CC} quiescent current		120		mA	
I_{OFF}	Shut down current		<1.0		μA	
V_{REG}	Reference Voltage for recommended application		2.85		V	

T2.0 1428

TABLE 3: AC Electrical Characteristics for Configuration

Symbol	Parameter	Min	Typ	Max	Unit
F_{L-U}	Frequency range	4.9		5.8	GHz
Linearity	Output power with 2.5% EVM at 54 Mbps OFDM signal when operating at 3.3V V_{CC}		18	20	dBm
	Output power level with 802.11a mask compliance across 4.9-5.8 GHz		23		dBm
G	Linear gain across 4.9~5.8GHz		26		dB
Det	Power detector output voltage range	0.3		1.7	V
2f, 3f, 4f, 5f	Harmonics at 22 dBm, without trapping capacitors		-40		dBc

T3.1 1428

TYPICAL PERFORMANCE CHARACTERISTICS

Test Conditions: $V_{CC} = 3.3V$, $T_A = 25^\circ C$, $V_{REG} = 2.85V$ unless otherwise noted

EVM for 54 Mbps Operation

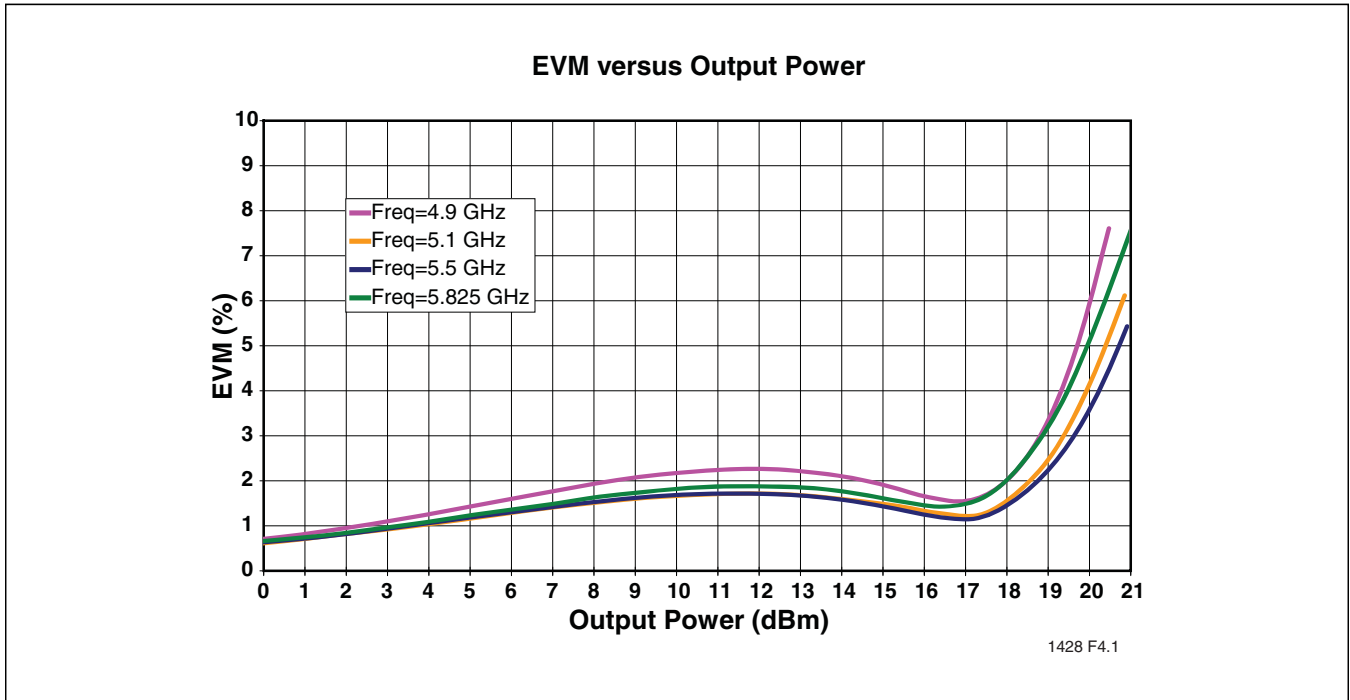

FIGURE 3: EVM versus Output Power

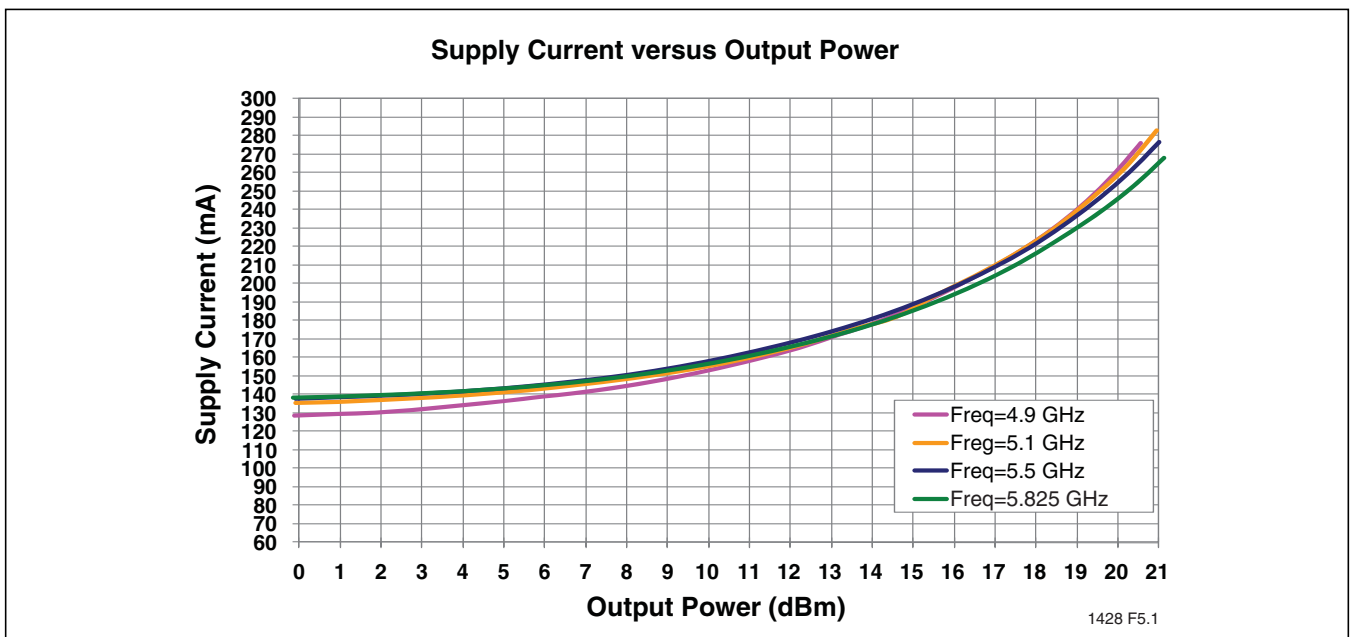

FIGURE 4: Power Supply Current versus Output Power

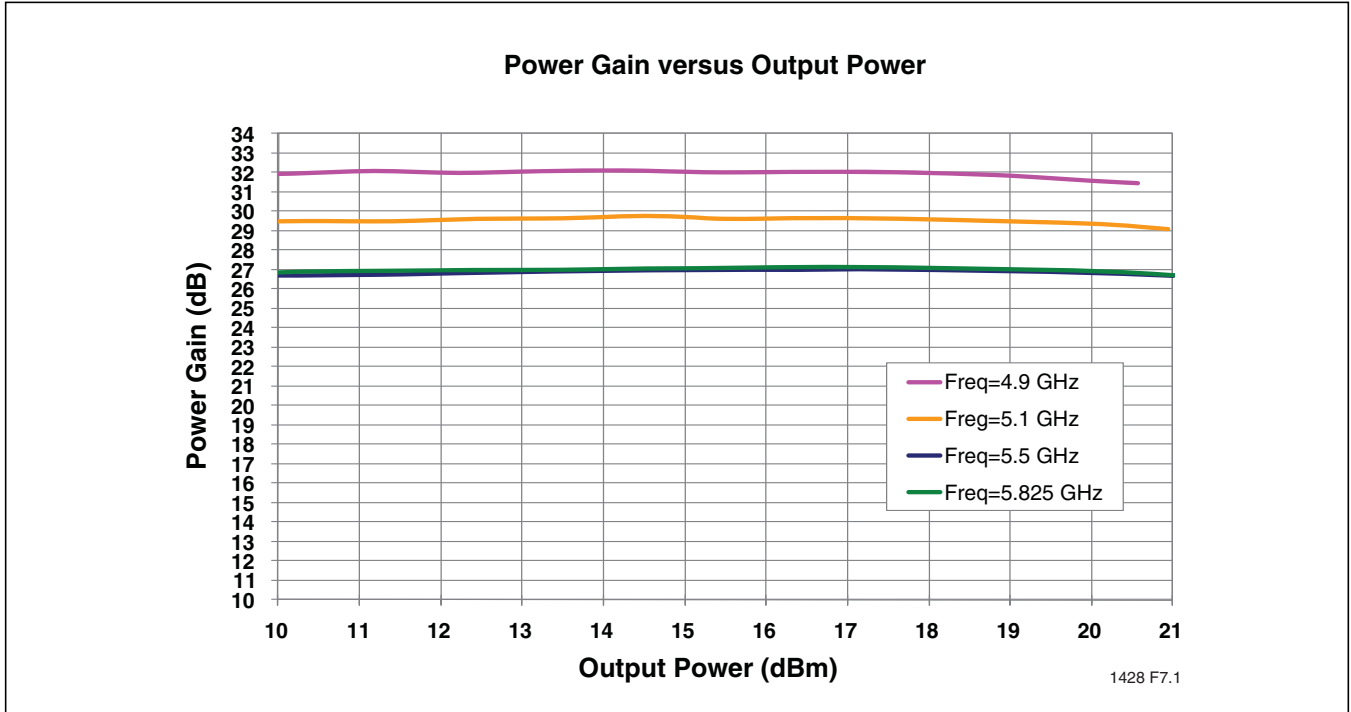

FIGURE 5: Power Gain versus Output Power

Maximum Mask Compliance

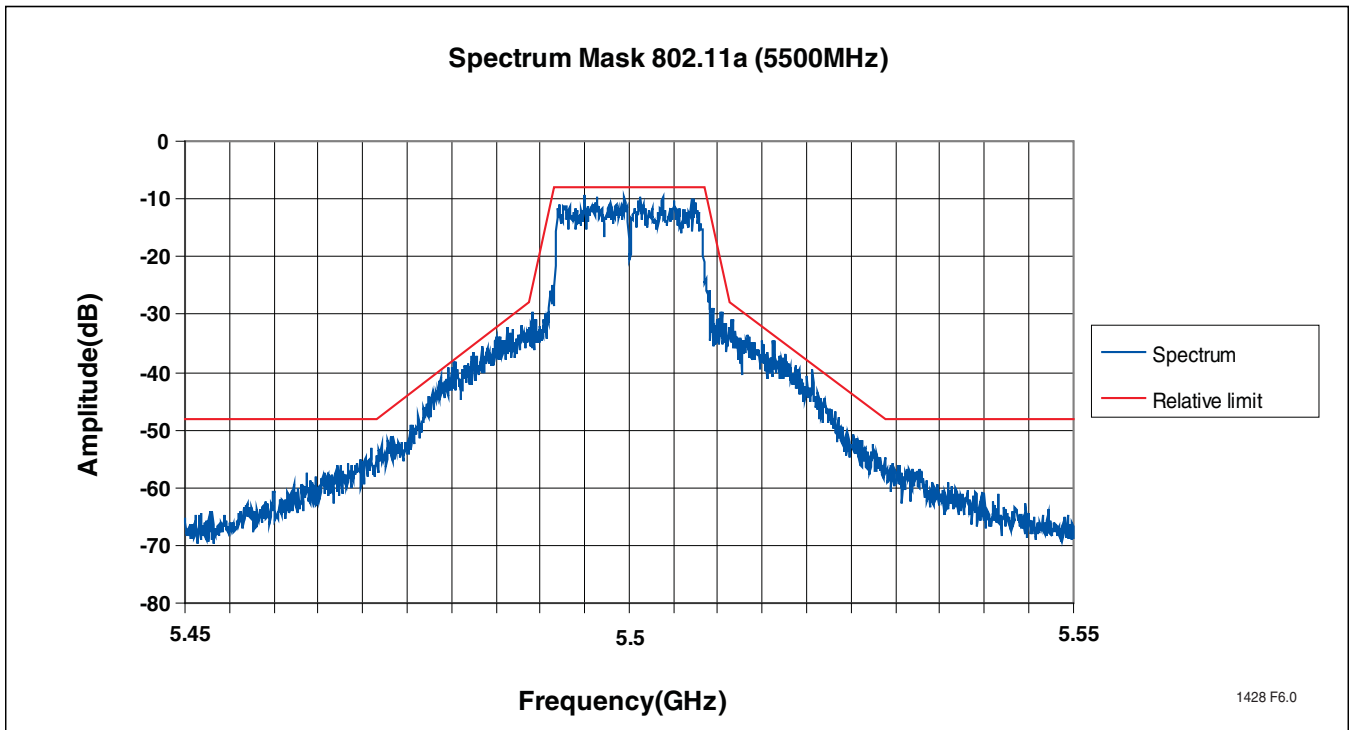

FIGURE 6: Frequency = 5.5 GHz at $P_{OUT} = 23.3$ dBm with $I_{CC} = 390$ mA

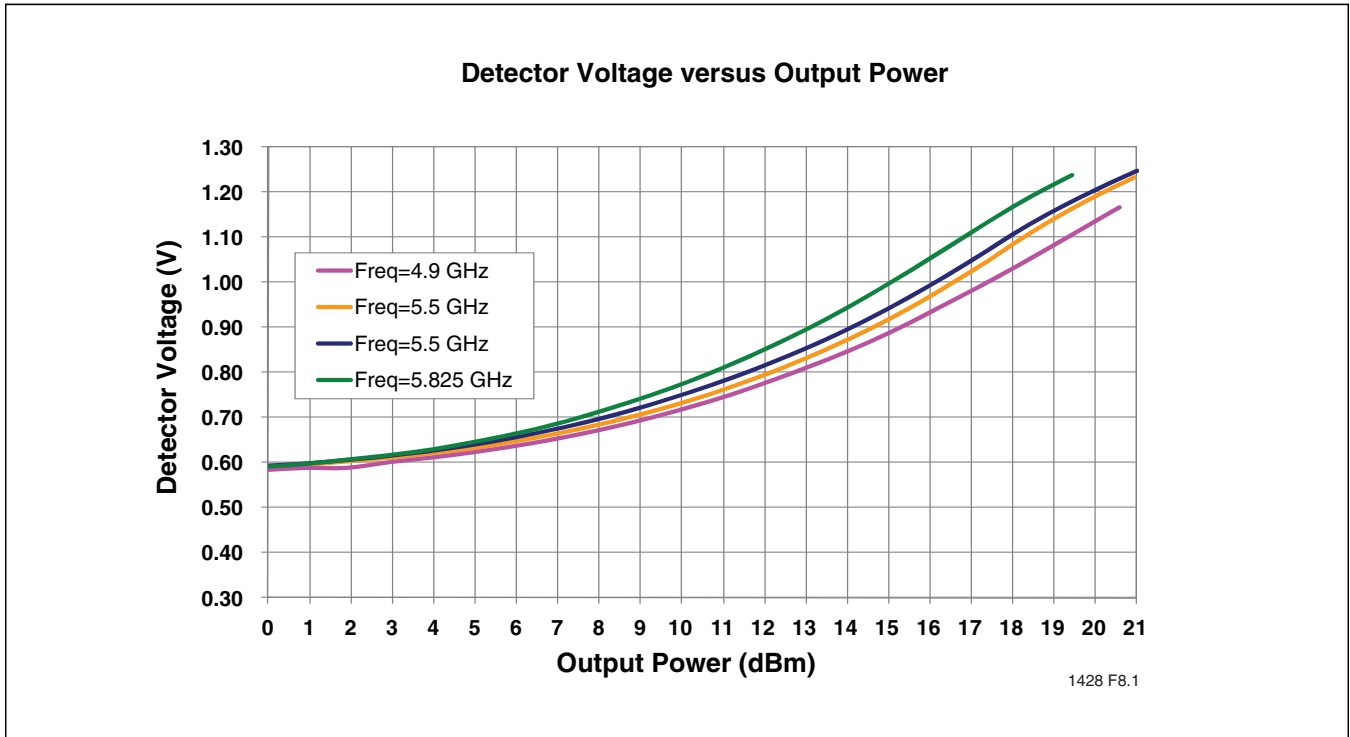

FIGURE 7: Detector Voltage vs Output Power

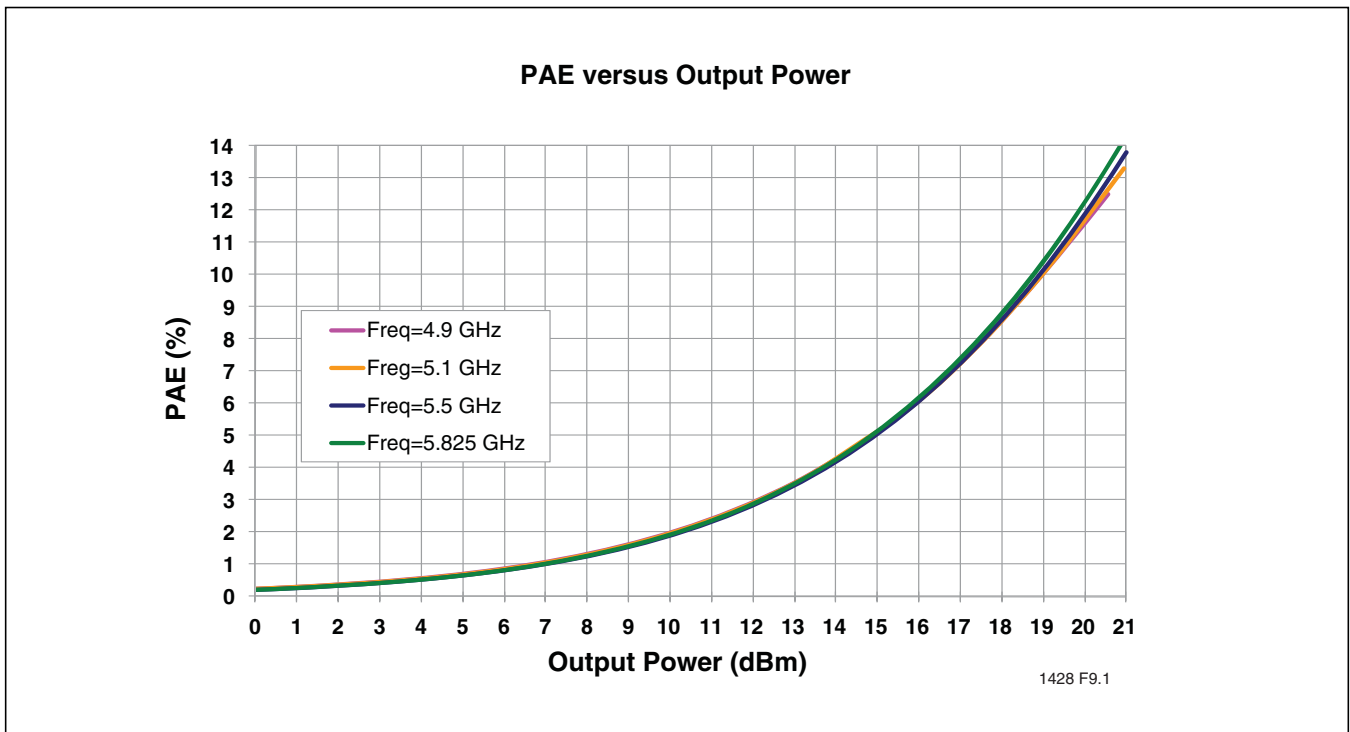
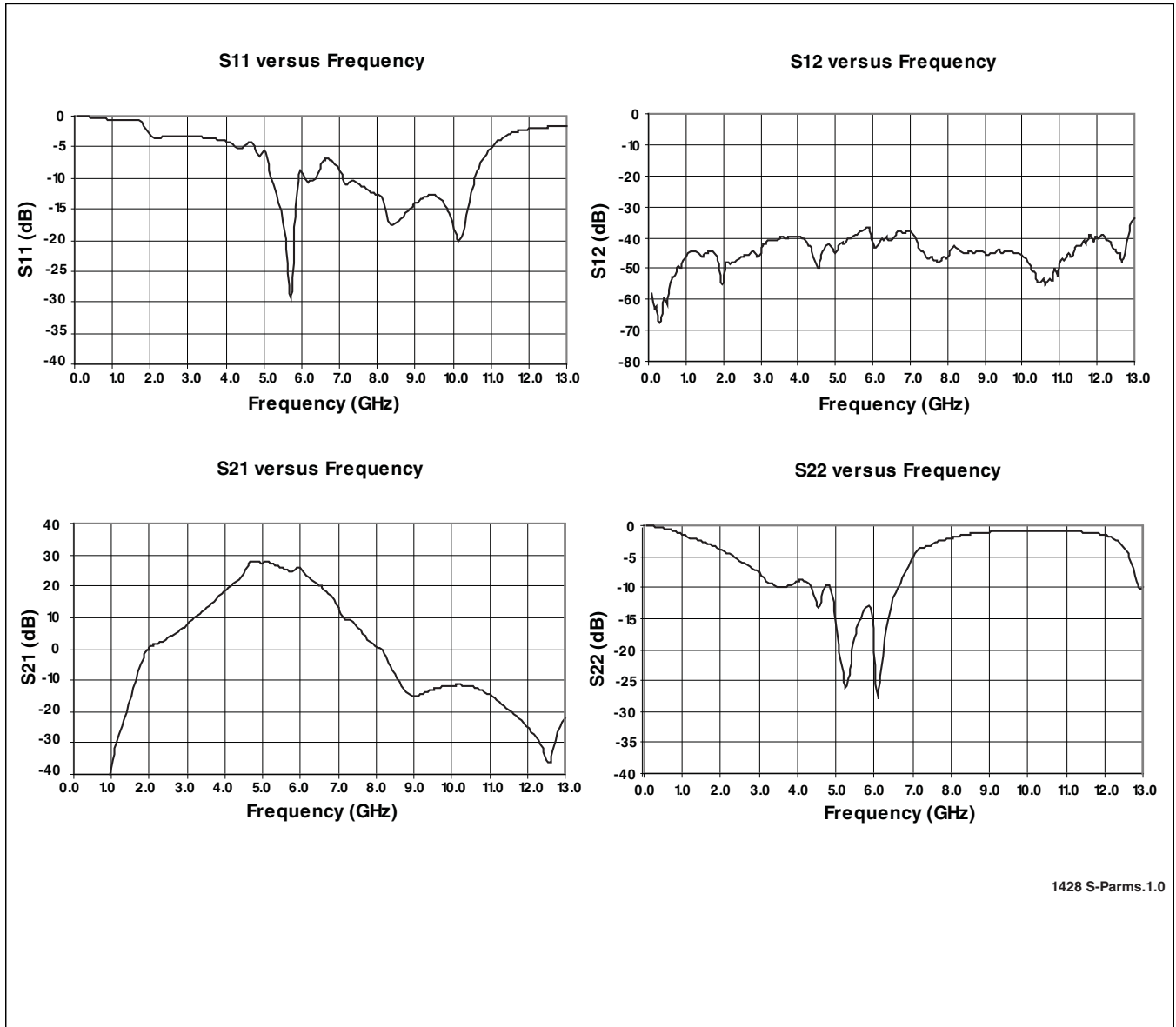

FIGURE 8: PAE vs Output Power



4.9-5.8 GHz High-Linearity Power Amplifier SST11CP15

Data Sheet



1428 S-Parms.1.0

FIGURE 9: S-Parameters



4.9-5.8 GHz High-Linearity Power Amplifier SST11CP15

Data Sheet

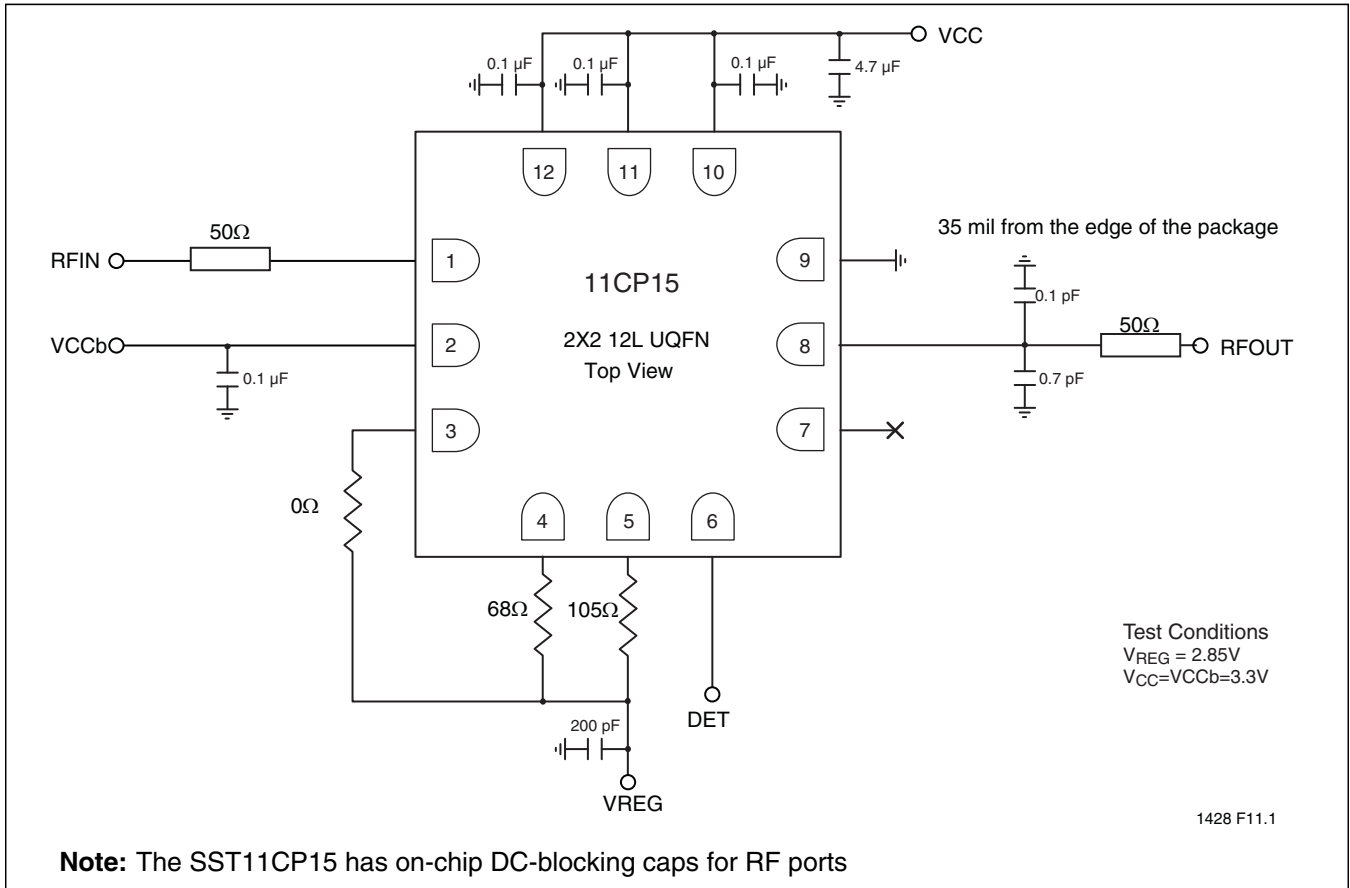

Note: The SST11CP15 has on-chip DC-blocking caps for RF ports

FIGURE 10: Typical Application for High-Linearity 802.11a/n Application ($V_{CC} = 3.3V$, $V_{REG} = 2.85V$)



4.9-5.8 GHz High-Linearity Power Amplifier SST11CP15

Data Sheet

PRODUCT ORDERING INFORMATION

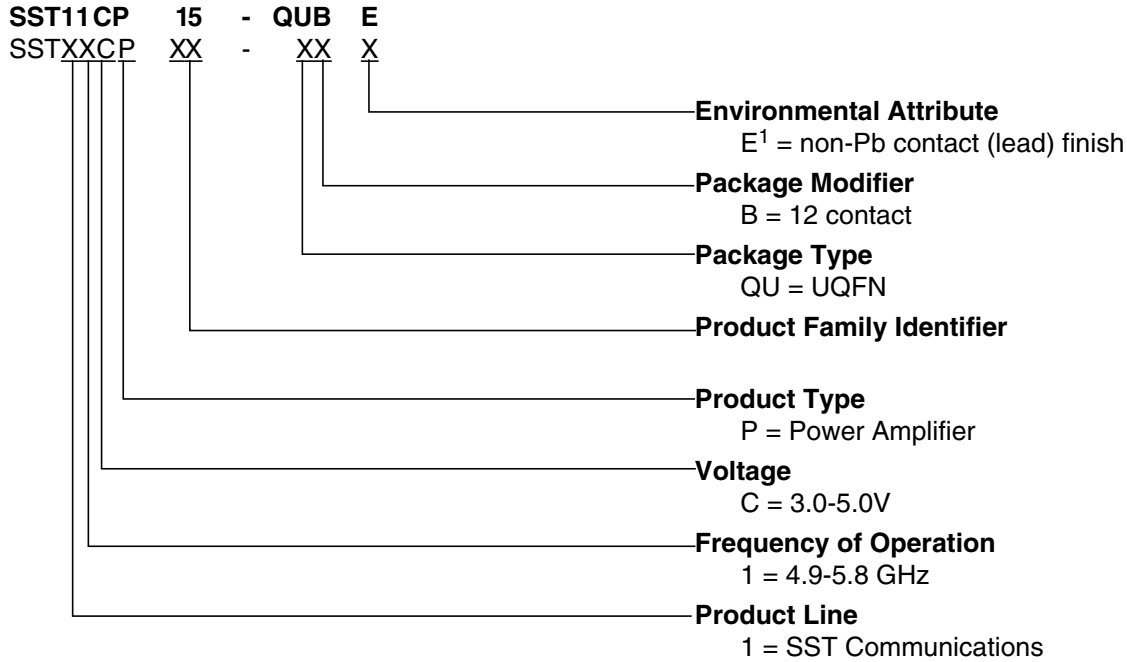

1. Environmental suffix "E" denotes non-Pb solder.
SST non-Pb solder devices are "RoHS Compliant".

Valid combinations for SST11CP15

SST11CP15-QUBE

SST11CP15 Evaluation Kits

SST11CP15-QUBE-K

Note: Valid combinations are those products in mass production or will be in mass production. Consult your SST sales representative to confirm availability of valid combinations and to determine availability of new combinations.

PACKAGING DIAGRAMS

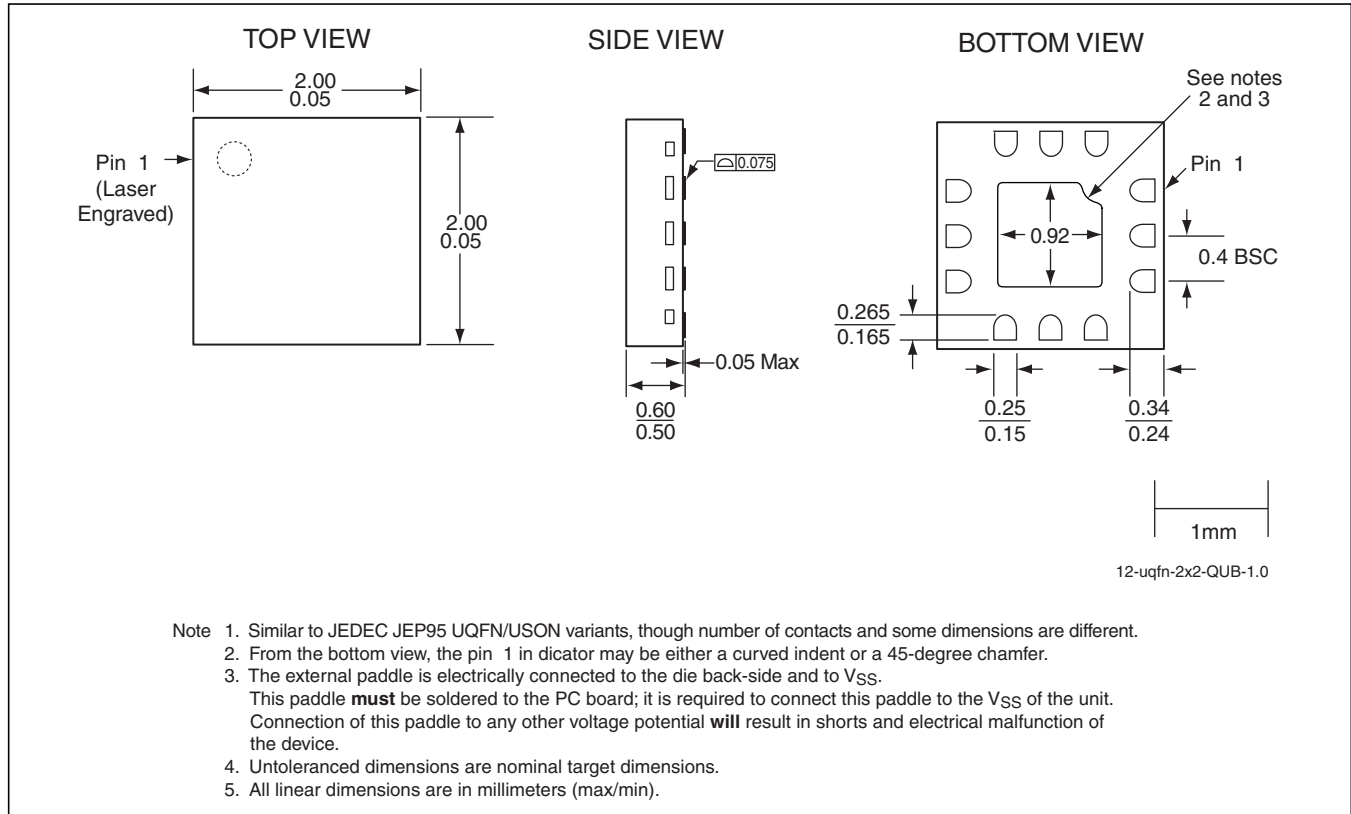

FIGURE 11: 12-contact Ultra-thin Quad Flat No-lead (UQFN)
SST Package Code: QUB

TABLE 4: Revision History

Revision	Description	Date
00	• Initial Release of Data Sheet	Jul 2010
01	• Updated Features on page 1; Table 2 on page 4; and Figures 3-5, 7,8, and 10.	Jan 2011

X-ON Electronics

Largest Supplier of Electrical and Electronic Components

Click to view similar products for [RF Amplifier](#) category:

Click to view products by [Microchip](#) manufacturer:

Other Similar products are found below :

[A82-1](#) [BGA622H6820XTSA1](#) [BGA 728L7 E6327](#) [BGB719N7ESDE6327XTMA1](#) [HMC397-SX](#) [HMC405](#) [HMC561-SX](#) [HMC8120-SX](#)
[HMC8121-SX](#) [HMC-ALH382-SX](#) [HMC-ALH476-SX](#) [SE2433T-R](#) [SMA3101-TL-E](#) [SMA39](#) [A66-1](#) [A66-3](#) [A67-1](#) [LX5535LQ](#) [LX5540LL](#)
[MAAM02350](#) [HMC3653LP3BETR](#) [HMC549MS8GETR](#) [HMC-ALH435-SX](#) [SMA101](#) [SMA32](#) [SMA411](#) [SMA531](#) [SST12LP17E-XX8E](#)
[SST12LP19E-QX6E](#) [WPM0510A](#) [HMC5929LS6TR](#) [HMC5879LS7TR](#) [HMC1126](#) [HMC1087F10](#) [HMC1086](#) [HMC1016](#) [SMA1212](#)
[MAX2689EWS+T](#) [MAAMSS0041TR](#) [MAAM37000-A1G](#) [LTC6430AIUF-15#PBF](#) [CHA5115-QDG](#) [SMA70-2](#) [SMA4011](#) [A231](#) [HMC-](#)
[AUH232](#) [LX5511LQ](#) [LX5511LQ-TR](#) [HMC7441-SX](#) [HMC-ALH310](#)