



**MICROCHIP**

---

**MPLAB<sup>®</sup> XC8 C Compiler  
User's Guide**

---

---

**Note the following details of the code protection feature on Microchip devices:**

- Microchip products meet the specification contained in their particular Microchip Data Sheet.
- Microchip believes that its family of products is one of the most secure families of its kind on the market today, when used in the intended manner and under normal conditions.
- There are dishonest and possibly illegal methods used to breach the code protection feature. All of these methods, to our knowledge, require using the Microchip products in a manner outside the operating specifications contained in Microchip's Data Sheets. Most likely, the person doing so is engaged in theft of intellectual property.
- Microchip is willing to work with the customer who is concerned about the integrity of their code.
- Neither Microchip nor any other semiconductor manufacturer can guarantee the security of their code. Code protection does not mean that we are guaranteeing the product as "unbreakable."

Code protection is constantly evolving. We at Microchip are committed to continuously improving the code protection features of our products. Attempts to break Microchip's code protection feature may be a violation of the Digital Millennium Copyright Act. If such acts allow unauthorized access to your software or other copyrighted work, you may have a right to sue for relief under that Act.

---

Information contained in this publication regarding device applications and the like is provided only for your convenience and may be superseded by updates. It is your responsibility to ensure that your application meets with your specifications. MICROCHIP MAKES NO REPRESENTATIONS OR WARRANTIES OF ANY KIND WHETHER EXPRESS OR IMPLIED, WRITTEN OR ORAL, STATUTORY OR OTHERWISE, RELATED TO THE INFORMATION, INCLUDING BUT NOT LIMITED TO ITS CONDITION, QUALITY, PERFORMANCE, MERCHANTABILITY OR FITNESS FOR PURPOSE. Microchip disclaims all liability arising from this information and its use. Use of Microchip devices in life support and/or safety applications is entirely at the buyer's risk, and the buyer agrees to defend, indemnify and hold harmless Microchip from any and all damages, claims, suits, or expenses resulting from such use. No licenses are conveyed, implicitly or otherwise, under any Microchip intellectual property rights unless otherwise stated.

*Microchip received ISO/TS-16949:2009 certification for its worldwide headquarters, design and wafer fabrication facilities in Chandler and Tempe, Arizona; Gresham, Oregon and design centers in California and India. The Company's quality system processes and procedures are for its PIC® MCUs and dsPIC® DSCs, KEELOQ® code hopping devices, Serial EEPROMs, microperipherals, nonvolatile memory and analog products. In addition, Microchip's quality system for the design and manufacture of development systems is ISO 9001:2000 certified.*

**QUALITY MANAGEMENT SYSTEM  
CERTIFIED BY DNV  
= ISO/TS 16949 =**

### Trademarks

The Microchip name and logo, the Microchip logo, AnyRate, AVR, AVR logo, AVR Freaks, BeaconThings, BitCloud, CryptoMemory, CryptoRF, dsPIC, FlashFlex, flexPWR, Helder, JukeBlox, KEELOQ, KEELOQ logo, Klear, LANCheck, LINK MD, maXStylus, maXTouch, MediaLB, megaAVR, MOST, MOST logo, MPLAB, OptoLyzer, PIC, picoPower, PICSTART, PIC32 logo, Prochip Designer, QTouch, RightTouch, SAM-BA, SpyNIC, SST, SST Logo, SuperFlash, tinyAVR, UNI/O, and XMEGA are registered trademarks of Microchip Technology Incorporated in the U.S.A. and other countries.

ClockWorks, The Embedded Control Solutions Company, EtherSynch, Hyper Speed Control, HyperLight Load, IntelliMOS, mTouch, Precision Edge, and Quiet-Wire are registered trademarks of Microchip Technology Incorporated in the U.S.A.

Adjacent Key Suppression, AKS, Analog-for-the-Digital Age, Any Capacitor, AnyIn, AnyOut, BodyCom, chipKIT, chipKIT logo, CodeGuard, CryptoAuthentication, CryptoCompanion, CryptoController, dsPICDEM, dsPICDEM.net, Dynamic Average Matching, DAM, ECAN, EtherGREEN, In-Circuit Serial Programming, ICSP, Inter-Chip Connectivity, JitterBlocker, KlearNet, KlearNet logo, Mindi, MiWi, motorBench, MPASM, MPF, MPLAB Certified logo, MPLIB, MPLINK, MultiTRAK, NetDetach, Omniscient Code Generation, PICDEM, PICDEM.net, PICKit, PICtail, PureSilicon, QMatrix, RightTouch logo, REAL ICE, Ripple Blocker, SAM-ICE, Serial Quad I/O, SMART-I.S., SQI, SuperSwitcher, SuperSwitcher II, Total Endurance, TSHARC, USBCheck, VariSense, ViewSpan, WiperLock, Wireless DNA, and ZENA are trademarks of Microchip Technology Incorporated in the U.S.A. and other countries.

SQTP is a service mark of Microchip Technology Incorporated in the U.S.A.

Silicon Storage Technology is a registered trademark of Microchip Technology Inc. in other countries.

GestIC is a registered trademark of Microchip Technology Germany II GmbH & Co. KG, a subsidiary of Microchip Technology Inc., in other countries.

All other trademarks mentioned herein are property of their respective companies.

© 2012-2016, Microchip Technology Incorporated, All Rights Reserved.

ISBN: 978-1-5224-1085-0

## Table of Contents

<b>Preface</b> .....	<b>7</b>
<b>Chapter 1. Compiler Overview</b>	
1.1 Introduction .....	13
1.2 Compiler Description and Documentation .....	13
1.3 Device Description .....	14
<b>Chapter 2. Common C Interface</b>	
2.1 Introduction .....	15
2.2 Background – The Desire for Portable Code .....	15
2.3 Using the CCI .....	18
2.4 ANSI Standard Refinement .....	19
2.5 ANSI Standard Extensions .....	27
2.6 Compiler Features .....	41
<b>Chapter 3. How To's</b>	
3.1 Introduction .....	43
3.2 Installing and Activating the Compiler .....	43
3.3 Invoking the Compiler .....	45
3.4 Writing Source Code .....	48
3.5 Getting My Application to Do What I Want .....	60
3.6 Understanding the Compilation Process .....	65
3.7 Fixing Code That Does Not Work .....	73
<b>Chapter 4. XC8 Command-line Driver</b>	
4.1 Introduction .....	77
4.2 Invoking the Compiler .....	78
4.3 The Compilation Sequence .....	81
4.4 Runtime Files .....	87
4.5 Compiler Output .....	88
4.6 Compiler Messages .....	90
4.7 MPLAB XC8 Driver Options .....	95
4.8 Option Descriptions .....	96
4.9 MPLAB X Option Equivalents .....	126
<b>Chapter 5. C Language Features</b>	
5.1 Introduction .....	135
5.2 ANSI C Standard Issues .....	135
5.3 Device-Related Features .....	137
5.4 Supported Data Types and Variables .....	149
5.5 Memory Allocation and Access .....	170
5.6 Operators and Statements .....	187

# MPLAB® XC8 C Compiler User's Guide

---

5.7 Register Usage .....	189
5.8 Functions .....	190
5.9 Interrupts .....	200
5.10 Main, Runtime Startup and Reset .....	210
5.11 Libraries .....	214
5.12 Mixing C and Assembly Code .....	216
5.13 Optimizations .....	228
5.14 Preprocessing .....	230
5.15 Linking Programs .....	241
<b>Chapter 6. Macro Assembler</b>	
6.1 Introduction .....	265
6.2 MPLAB XC8 Assembly Language .....	266
6.3 Assembly-Level Optimizations .....	294
6.4 Assembly List Files .....	295
<b>Chapter 7. Linker</b>	
7.1 Introduction .....	305
7.2 Operation .....	305
7.3 Relocation and Psects .....	313
7.4 Map Files .....	314
<b>Chapter 8. Utilities</b>	
8.1 Introduction .....	319
8.2 Librarian .....	320
8.3 HEXMATE .....	323
8.4 Hash Functions .....	332
<b>Appendix A. Library Functions</b>	
A.1 Introduction .....	339
<b>Appendix B. Embedded Compiler Compatibility Mode</b>	
B.1 Introduction .....	431
B.2 Compiling in Compatibility Mode .....	431
B.3 Syntax Compatibility .....	432
B.4 Data Type .....	433
B.5 Operator .....	433
B.6 Extended Keywords .....	434
B.7 Intrinsic Functions .....	435
B.8 Pragmas .....	436
<b>Appendix C. Error and Warning Messages</b>	
C.1 Introduction .....	437
<b>Appendix D. Implementation-Defined Behavior</b>	
D.1 Introduction .....	565
D.2 Translation (G.3.1) .....	565
D.3 Environment (G.3.2) .....	565
D.4 Identifiers (G.3.3) .....	566
D.5 Characters (G.3.4) .....	566

# Table of Contents

---

D.6 Integers (G.3.5) .....	567
D.7 Floating-Point (G.3.6) .....	568
D.8 Arrays and Pointers (G.3.7) .....	568
D.9 Registers (G.3.8) .....	568
D.10 Structures, Unions, Enumerations, and Bit-Fields (G.3.9) .....	569
D.11 Qualifiers (G.3.10) .....	569
D.12 Declarators (G.3.11) .....	569
D.13 Statements (G.3.12) .....	569
D.14 Preprocessing Directives (G.3.13) .....	570
D.15 Library Functions (G.3.14) .....	571
<b>Glossary .....</b>	<b>573</b>
<b>Index .....</b>	<b>593</b>
<b>Worldwide Sales and Service .....</b>	<b>606</b>

# MPLAB® XC8 C Compiler User's Guide

---

NOTES:

---

---

## Preface

---

---

### NOTICE TO CUSTOMERS

All documentation becomes dated, and this manual is no exception. Microchip tools and documentation are constantly evolving to meet customer needs, so some actual dialogs and/or tool descriptions can differ from those in this document. Please refer to our web site ([www.microchip.com](http://www.microchip.com)) to obtain the latest documentation available.

Documents are identified with a “DS” number. This number is located on the bottom of each page, in front of the page number. The numbering convention for the DS number is “DSXXXXA”, where “XXXX” is the document number and “A” is the revision level of the document.

For the most up-to-date information on development tools, see the MPLAB® IDE online help. Select the Help menu, and then Topics to open a list of available online help files.

## INTRODUCTION

This chapter contains general information that will be useful to know before using the MPLAB® XC8 C Compiler User's Guide. Items discussed in this chapter include:

- [Document Layout](#)
- [Conventions Used in this Guide](#)
- [Recommended Reading](#)
- [Recommended Reading](#)
- [The Microchip Web Site](#)
- [Development Systems Customer Change Notification Service](#)
- [Customer Support](#)
- [Document Revision History](#)

## DOCUMENT LAYOUT

The MPLAB XC8 C Compiler User's Guide is organized as follows:

- [Chapter 1. Compiler Overview](#)
- [Chapter 2. Common C Interface](#)
- [Chapter 3. How To's](#)
- [Chapter 4. XC8 Command-line Driver](#)
- [Chapter 5. C Language Features](#)
- [Chapter 6. Macro Assembler](#)
- [Chapter 7. Linker](#)
- [Chapter 8. Utilities](#)
- [Appendix A. Library Functions](#)
- [Appendix B. Embedded Compiler Compatibility Mode](#)
- [Appendix C. Error and Warning Messages](#)
- [Appendix D. Implementation-Defined Behavior](#)
- [Glossary](#)
- [Index](#)

# MPLAB® XC8 C Compiler User's Guide

## CONVENTIONS USED IN THIS GUIDE

This manual uses the following documentation conventions:

### DOCUMENTATION CONVENTIONS

Description	Represents	Examples
<b>Arial font:</b>		
Italic characters	Referenced books	<i>MPLAB® IDE User's Guide</i>
	Emphasized text	...is the <i>only</i> compiler...
Initial caps	A window	the Output window
	A dialog	the Settings dialog
	A menu selection	select Enable Programmer
Quotes	A field name in a window or dialog	"Save project before build"
Underlined, italic text with right angle bracket	A menu path	<u><i>File&gt;Save</i></u>
Bold characters	A dialog button	Click <b>OK</b>
	A tab	Click the <b>Power</b> tab
N'Rnnnn	A number in verilog format, where N is the total number of digits, R is the radix and n is a digit.	4'b0010, 2'hF1
Text in angle brackets < >	A key on the keyboard	Press <Enter>, <F1>
<b>Courier New font:</b>		
Plain Courier New	Sample source code	#define START
	Filenames	autoexec.bat
	File paths	c:\mcc18\h
	Keywords	_asm, _endasm, static
	Command-line options	-Opa+, -Opa-
	Bit values	0, 1
	Constants	0xFF, 'A'
Italic Courier New	A variable argument	<i>file.o</i> , where <i>file</i> can be any valid filename
Square brackets [ ]	Optional arguments	mcc18 [options] <i>file</i> [options]
Curly brackets and pipe character: {   }	Choice of mutually exclusive arguments; an OR selection	errorlevel {0 1}
Ellipses...	Replaces repeated text	var_name [, var_name...]
	Represents code supplied by user	void main (void) { ... }



## RECOMMENDED READING

This user's guide describes how to use MPLAB XC8 C Compiler. Other useful documents are listed below. The following Microchip documents are available and recommended as supplemental reference resources.

### **Readme for MPLAB XC8 C Compiler**

For the latest information on using MPLAB XC8 C Compiler, read *MPLAB® XC8 C Compiler Release Notes* (an HTML file) in the Docs subdirectory of the compiler's installation directory. The release notes contain update information and known issues that cannot be included in this user's guide.

### **Readme Files**

For the latest information on using other tools, read the tool-specific Readme files in the Readmes subdirectory of the MPLAB IDE installation directory. The Readme files contain update information and known issues that cannot be included in this user's guide.

## THE MICROCHIP WEB SITE

Microchip provides online support via our web site at [www.microchip.com](http://www.microchip.com). This web site is used as a means to make files and information easily available to customers. Accessible by using your favorite Internet browser, the web site contains the following information:

- **Product Support** – Data sheets and errata, application notes and sample programs, design resources, user's guides and hardware support documents, latest software releases and archived software
- **General Technical Support** – Frequently Asked Questions (FAQs), technical support requests, online discussion groups, Microchip consultant program member listing
- **Business of Microchip** – Product selector and ordering guides, latest Microchip press releases, listing of seminars and events, listings of Microchip sales offices, distributors and factory representatives

## DEVELOPMENT SYSTEMS CUSTOMER CHANGE NOTIFICATION SERVICE

Microchip's customer notification service helps keep customers current on Microchip products. Subscribers will receive e-mail notification whenever there are changes, updates, revisions or errata that are related to a specified product family or development tool of interest.

To register, access the Microchip web site at [www.microchip.com](http://www.microchip.com), click on **Customer Change Notification** and follow the registration instructions.

The Development Systems product group categories are:

- **Compilers** – The latest information on Microchip C compilers, assemblers, linkers and other language tools. These include all MPLAB C compilers; all MPLAB assemblers (including MPASM™ assembler); all MPLAB linkers (including MPLINK™ object linker); and all MPLAB librarians (including MPLIB™ object librarian).
- **Emulators** – The latest information on Microchip in-circuit emulators. This includes the MPLAB REAL ICE™ and MPLAB ICE 2000 in-circuit emulators.
- **In-Circuit Debuggers** – The latest information on the Microchip in-circuit debuggers. This includes MPLAB ICD 3 in-circuit debuggers and PICKit™ 3 debug express.
- **MPLAB® IDE** – The latest information on Microchip MPLAB IDE, the Windows® Integrated Development Environment for development systems tools. This list is focused on the MPLAB IDE, MPLAB IDE Project Manager, MPLAB Editor and MPLAB SIM simulator, as well as general editing and debugging features.
- **Programmers** – The latest information on Microchip programmers. These include production programmers such as MPLAB REAL ICE in-circuit emulator, MPLAB ICD 3 in-circuit debugger and MPLAB PM3 device programmers. Also included are nonproduction development programmers such as PICSTART® Plus and PICKit 2 and 3.

## CUSTOMER SUPPORT

Users of Microchip products can receive assistance through several channels:

- Distributor or Representative
- Local Sales Office
- Field Application Engineer (FAE)
- Technical Support

Customers should contact their distributor, representative or field application engineer (FAE) for support. Local sales offices are also available to help customers. A listing of sales offices and locations is included in the back of this document.

Technical support is available through the web site at:

<http://www.microchip.com/support>

## DOCUMENT REVISION HISTORY

### Revision G (November 2016)

- Expanded sections on interrupts to deal with new devices with vector tables
- Added new driver option `--UNDEFINTS` and `ivt` suboption to `--RUNTIME`
- Added details on new assembler instructions and directives
- Clarified usage of EEPROM functions
- Added new errata workaround information
- Updated MPLAB X IDE optimizations project properties dialog
- Expanded section on HEXMATE hash algorithms
- Added new error and warning messages

### Revision F (December 2015)

- Added new “How To’s”
- Added new driver option, `--DEP`, expanded `--OPT`, and updated `-V` option
- Updated predefined macros table
- Improved function allocation sections
- Added descriptions of new ‘relaxed’ 32-bit floating-point routines; new `__fpnormalize` function
- Added `EXTRN` assembler directive
- Expanded assembly optimizations section
- Added new section on writing reentrant assembly routines with parameters
- Revised the sections relating to the main linker options used to link psects
- Added new section on HEXMATE algorithms; included new examples
- Added new error and warning messages

### Revision E (January 2015)

- Added new “How To’s”
- Detailed the compiler’s use of hardware multiply instructions
- Updated information relating to psect definitions and their effect on optimizations
- Corrected information relating to maximum reentrant-function stack sizes
- Updated compiler warning and error messages; improved message descriptions relating to fixup errors and malformed arrays
- Added further information relating to customizing user-defined psects
- Improved `printf` library function description and expanded code example
- Added new `--MAXIPIC` and `--NOFALLBACK` options
- Many general corrections and improvements

## Revision D (Dec 2013)

- Added new information relating to the software stack and function reentrancy.
- Added information relating to code profiling features offered by the compiler.
- Removed information pertaining to MPLAB 8 IDE.
- Added new “How To’s”
- Removed sections on OBJTOHEX and CROMWELL.
- Added additional information relating to assembly code formats and operators.
- Corrected Fletcher algorithms used by HEXMATE.
- Added new driver options and updated existing option descriptions.
- Added and updated macros, built-ins and functions in Library Function chapter.
- Updated compiler warning and error messages.

## Revision C (May 2013)

- Added Embedded Compiler Compatibility Mode chapter.
- Added information relating to new ELF/DWARF debugging files.
- Added new driver options and updated existing option descriptions.
- Updated MPLAB X IDE option dialog descriptions relating to compiler options.
- Expanded information relating to the available optimizations.
- Added code to illustrate algorithms used by HEXMATE.
- Updated compiler warning and error messages.
- Updated information relating to list and map file contents.
- Added information about multiplication routines.
- Expanded information about eeprom variables and bit objects.
- Expanded information relating to the configuration pragma.
- Added information and examples using the `__section()` specifier.
- Expanded and extended information relating to assembly code deviations and assembler directives.

## Revision B (July 2012)

- Added How To’s chapter.
- Expanded section relating to PIC18 erratas.
- Updated the section relating to compiler optimization settings.
- Updated MPLAB v8 and MPLAB X IDE project option dialogs.
- Added sections describing PIC18 far qualifier and in-line function qualifier.
- Expanded section describing the operation of the `main()` function
- Expanded information about equivalent assembly symbols for Baseline parts.
- Updated the table of predefined macro symbols.
- Added section on `#pragma addrqual`
- Added sections to do with in-lining functions
- Updated diagrams and text associated with call graphs in the list file
- Updated library function section to be consistent with packaged libraries
- Added new compiler warnings and errors.
- Added new chapter describing the Common C Interface Standard (CCI)

## Revision A (February 2012)

Initial release of this document.

---

---

## Chapter 1. Compiler Overview

---

---

### 1.1 INTRODUCTION

This chapter is an overview of the MPLAB<sup>®</sup> XC8 C Compiler, including these topics.

- [Compiler Description and Documentation](#)
- [Device Description](#)

### 1.2 COMPILER DESCRIPTION AND DOCUMENTATION

The MPLAB XC8 C Compiler is a free-standing, optimizing ISO C90 (popularly known as ANSI C) compiler. It supports all 8-bit PIC<sup>®</sup> microcontrollers: PIC10, PIC12, PIC16 and PIC18 series devices, as well as the PIC14000 device.

The compiler is available for several popular operating systems, including 32- and 64-bit Windows<sup>®</sup> and Mac OS<sup>®</sup> X 10.5. The compiler might also run on the various Linux<sup>®</sup> distributions, such as Oracle Enterprise Linux 5, Ubuntu 8.x and 10.04, Red Hat Enterprise Linux.

The compiler is available in three operating modes: Free, Standard or PRO. The Standard and PRO operating modes are licensed modes and require a serial number to enable them. Free mode is available for unlicensed customers. The basic compiler operation, supported devices and available memory are identical across all modes. The modes only differ in the level of optimization employed by the compiler.

#### 1.2.1 Conventions

Throughout this manual, the term “compiler” is used. It can refer to all, or a subset of, the collection of applications that comprise the MPLAB XC8 C Compiler. When it is not important to identify which application performed an action, it will be attributed to “the compiler”.

In a similar manner, “compiler” is often used to refer to the command-line driver; although specifically, the driver for the MPLAB XC8 C Compiler package is named `x8c`. The driver and its options are discussed in [Section 4.7 “MPLAB XC8 Driver Options”](#). Accordingly, “compiler options” commonly refers to command-line driver options.

In a similar fashion, “compilation” refers to all or a selection of steps involved in generating an executable binary image from source code.

## 1.3 DEVICE DESCRIPTION

This compiler supports 8-bit Microchip PIC devices with baseline, mid-range, Enhanced mid-range, and PIC18 cores. The following descriptions indicate the distinctions within those device cores:

The baseline core uses a 12-bit-wide instruction set and is available in PIC10, PIC12 and PIC16 part numbers.

The enhanced baseline core also uses a 12-bit instruction set, but this set includes additional instructions. Some of the enhanced baseline chips support interrupts and the additional instructions used by interrupts. These devices are available in PIC12 and PIC16 part numbers.

The mid-range core uses a 14-bit-wide instruction set that includes more instructions than the baseline core. It has larger data memory banks and program memory pages, as well. It is available in PIC12, PIC14 and PIC16 part numbers.

The Enhanced mid-range core also uses a 14-bit-wide instruction set but incorporates additional instructions and features. There are both PIC12 and PIC16 part numbers that are based on the Enhanced mid-range core.

The PIC18 core instruction set is 16 bits wide and features additional instructions and an expanded register set. PIC18 core devices have part numbers that begin with PIC18.

The compiler takes advantage of the target device's instruction set, addressing modes, memory, and registers whenever possible.

See [Section 4.8.19 "--CHIPINFO: Display List of Supported Devices"](#) for information on finding the full list of devices that are supported by the compiler.

---

---

## Chapter 2. Common C Interface

---

---

### 2.1 INTRODUCTION

The Common C Interface (CCI) is available with all MPLAB XC C compilers and is designed to enhance code portability between these compilers. For example, CCI-conforming code would make it easier to port from a PIC18 MCU using the MPLAB XC8 C compiler to a PIC24 MCU using the MPLAB XC16 C compiler.

The CCI assumes that your source code already conforms to the ANSI Standard. If you intend to use the CCI, it is your responsibility to write code that conforms. Legacy projects will need to be migrated to achieve conformance. A compiler option must also be set to ensure that the operation of the compiler is consistent with the interface when the project is built.

The following topics are examined in this chapter of the MPLAB XC8 C Compiler User's Guide:

- [Background – The Desire for Portable Code](#)
- [Using the CCI](#)
- [ANSI Standard Refinement](#)
- [ANSI Standard Extensions](#)
- [Compiler Features](#)

### 2.2 BACKGROUND – THE DESIRE FOR PORTABLE CODE

All programmers want to write portable source code.

Portability means that the same source code can be compiled and run in a different execution environment than that for which it was written. Rarely can code be one hundred percent portable, but the more tolerant it is to change, the less time and effort it takes to have it running in a new environment.

Embedded engineers typically think of code portability as being across target devices, but this is only part of the situation. The same code could be compiled for the same target but with a different compiler. Differences between those compilers might lead to the code failing at compile time or runtime, so this must be considered as well.

You can only write code for one target device and only use one brand of compiler, but if there is no regulation of the compiler's operation, simply updating your compiler version can change your code's behavior.

Code must be portable across targets, tools, and time to be truly flexible.

Clearly, this portability cannot be achieved by the programmer alone, since the compiler vendors can base their products on different technologies, implement different features and code syntax, or improve the way their product works. Many a great compiler optimization has broken many an unsuspecting project.

Standards for the C language have been developed to ensure that change is managed and code is more portable. The American National Standards Institute (ANSI) publishes standards for many disciplines, including programming languages. The ANSI C Standard is a universally adopted standard for the C programming language.

## 2.2.1 The ANSI Standard

The ANSI C Standard has to reconcile two opposing goals: freedom for compilers vendors to target new devices and improve code generation, with the known functional operation of source code for programmers. If both goals can be met, source code can be made portable.

The standard is implemented as a set of rules which detail not only the syntax that a conforming C program must follow, but the semantic rules by which that program will be interpreted. Thus, for a compiler to conform to the standard, it must ensure that a conforming C program functions as described by the standard.

The standard describes *implementation*, the set of tools, and the runtime environment on which the code will run. If any of these change, e.g., you build for, and run on, a different target device, or if you update the version of the compiler you use to build, then you are using a different implementation.

The standard uses the term *behavior* to mean the external appearance or action of the program. It has nothing to do with how a program is encoded.

Since the standard is trying to achieve goals that could be construed as conflicting, some specifications appear somewhat vague. For example, the standard states that an `int` type must be able to hold at least a 16-bit value, but it does not go as far as saying what the size of an `int` actually is; and the action of right-shifting a signed integer can produce different results on different implementations; yet, these different results are still ANSI C compliant.

If the standard is too strict, device architectures cannot allow the compiler to conform.<sup>1</sup> But, if it is too weak, programmers would see wildly differing results within different compilers and architectures, and the standard would lose its effectiveness.

The standard organizes source code whose behavior is not fully defined into groups that include the following behaviors:

<b>Implementation-defined behavior</b>	This is unspecified behavior in which each implementation documents how the choice is made.
<b>Unspecified behavior</b>	The standard provides two or more possibilities and imposes no further requirements on which possibility is chosen in any particular instance.
<b>Undefined behavior</b>	This is behavior for which the standard imposes no requirements.

Code that strictly conforms to the standard does not produce output that is dependent on any unspecified, undefined, or implementation-defined behavior. The size of an `int`, which was used as an example earlier, falls into the category of behavior that is defined by implementation. That is to say, the size of an `int` is defined by which compiler is being used, how that compiler is being used, and the device that is being targeted.

All the MPLAB XC compilers conform to the ANSI X3.159-1989 Standard for programming languages (with the exception of the MPLAB XC8 compiler's inability to allow recursion, as mentioned in the footnote). This is commonly called the C89 Standard. Some features from the later standard, C99, are also supported.

---

1. For example, the mid-range PIC® microcontrollers do not have a data stack. Because a compiler targeting this device cannot implement recursion, it (strictly speaking) cannot conform to the ANSI C Standard. This example illustrates a situation in which the standard is too strict for mid-range devices and tools.



For freestanding implementations (or for what we typically call embedded applications), the standard allows non-standard extensions to the language, but obviously does not enforce how they are specified or how they work. When working so closely to the device hardware, a programmer needs a means of specifying device setup and interrupts, as well as utilizing the often complex world of small-device memory architectures. This cannot be offered by the standard in a consistent way.

While the ANSI C Standard provides a mutual understanding for programmers and compiler vendors, programmers need to consider the implementation-defined behavior of their tools and the probability that they may need to use extensions to the C language that are non-standard. Both of these circumstances can have an impact on code portability.

## 2.2.2 The Common C Interface

The Common C Interface (CCI) supplements the ANSI C Standard and makes it easier for programmers to achieve consistent outcomes on all Microchip devices when using any of the MPLAB XC C compilers.

It delivers the following improvements, all designed with portability in mind.

<b>Refinement of the ANSI C Standard</b>	The CCI documents specific behavior for some code in which actions are implementation-defined behavior under the ANSI C Standard. For example, the result of right-shifting a signed integer is fully defined by the CCI. Note that many implementation-defined items that closely couple with device characteristics, such as the size of an <code>int</code> , are not defined by the CCI.
<b>Consistent syntax for non-standard extensions</b>	The CCI non-standard extensions are mostly implemented using keywords with a uniform syntax. They replace keywords, macros and attributes that are the native compiler implementation. The interpretation of the keyword can differ across each compiler, and any arguments to the keywords can be device specific.
<b>Coding guidelines</b>	The CCI can indicate advice on how code should be written so that it can be ported to other devices or compilers. While you may choose not to follow the advice, it will not conform to the CCI.

## 2.3 USING THE CCI

The CCI allows enhanced portability by refining implementation-defined behavior and standardizing the syntax for extensions to the language.

The CCI is something you choose to follow and put into effect, thus it is relevant for new projects, although you can choose to modify existing projects so they conform.

For your project to conform to the CCI, you must do the following things.

- **Enable the CCI**

Select the MPLAB X IDE widget *Use CCI Syntax* in your project, or use the command-line option that is equivalent.

- **Include `<xc.h>` in every module**

Some CCI features are only enabled if this header is seen by the compiler.

- **Ensure ANSI compliance**

Code that does not conform to the ANSI C Standard does not conform to the CCI.

- **Observe refinements to ANSI by the CCI**

Some ANSI implementation-defined behavior is defined explicitly by the CCI.

- **Use the CCI extensions to the language**

Use the CCI extensions rather than the native language extensions.

The next sections detail specific items associated with the CCI. These items are segregated into those that refine the standard, those that deal with the ANSI C Standard extensions, and other miscellaneous compiler options and usage. Guidelines are indicated with these items.

If any implementation-defined behavior or any non-standard extension is not discussed in this document, then it is not part of the CCI. For example, GCC case ranges, label addresses, and 24-bit `short long` types are not part of the CCI. Programs which use these features do not conform to the CCI. The compiler may issue a warning or error to indicate a non-CCI feature has been used and the CCI is enabled.

## 2.4 ANSI STANDARD REFINEMENT

The following topics describe how the CCI refines the implementation-defined behaviors outlined in the ANSI C Standard.

### 2.4.1 Source File Encoding

Under the CCI, a source file must be written using characters from the 7-bit ASCII set. Lines can be terminated using a *line feed* (`\n`) or *carriage return* (`\r`) that is immediately followed by a *line feed*. Escaped characters can be used in character constants or string literals to represent extended characters that are not in the basic character set.

#### 2.4.1.1 EXAMPLE

The following shows a string constant being defined that uses escaped characters.

```
const char myName[] = "Bj\370rk\n";
```

#### 2.4.1.2 DIFFERENCES

All compilers have used this character set.

#### 2.4.1.3 MIGRATION TO THE CCI

No action required.

### 2.4.2 The Prototype for `main`

The prototype for the `main()` function is:

```
int main(void);
```

#### 2.4.2.1 EXAMPLE

The following shows an example of how `main()` might be defined:

```
int main(void)
{
    while(1)
        process();
}
```

#### 2.4.2.2 DIFFERENCES

The 8-bit compilers used a `void` return type for this function.

#### 2.4.2.3 MIGRATION TO THE CCI

Each program has one definition for the `main()` function. Confirm the return type for `main()` in all projects previously compiled for 8-bit targets.

### 2.4.3 Header File Specification

Header file specifications that use directory separators do not conform to the CCI.

#### 2.4.3.1 EXAMPLE

The following example shows two conforming include directives.

```
#include <usb_main.h>
#include "global.h"
```

## 2.4.3.2 DIFFERENCES

Header file specifications that use directory separators have been allowed in previous versions of all compilers. Compatibility problems arose when Windows-style separators “\” were used and the code was compiled under other host operating systems. Under the CCI, no directory separators should be used.

## 2.4.3.3 MIGRATION TO THE CCI

Any `#include` directives that use directory separators in the header file specifications should be changed. Remove all but the header file name in the directive. Add the directory path to the compiler's include search path or MPLAB X IDE equivalent. This will force the compiler to search the directories specified with this option.

For example, the following code:

```
#include <inc/lcd.h>
```

should be changed to:

```
#include <lcd.h>
```

and the path to the `inc` directory added to the compiler's header search path in your MPLAB X IDE project properties, or on the command-line as follows:

```
-Ilcd
```

## 2.4.4 Include Search Paths

When you include a header file under the CCI, the file should be discoverable in the paths searched by the compiler that are detailed below.

Header files specified in angle bracket delimiters `< >` should be discoverable in the search paths that are specified by `-I` options (or the equivalent MPLAB X IDE option), or in the standard compiler `include` directories. The `-I` options are searched in the order in which they are specified.

Header files specified in quote characters `" "` should be discoverable in the current working directory or in the same directories that are searched when the header files are specified in angle bracket delimiters (as above). In the case of an MPLAB X project, the current working directory is the directory in which the C source file is located. If unsuccessful, the search paths should be to the same directories searched when the header file is specified in angle bracket delimiters.

Any other options to specify search paths for header files do not conform to the CCI.

### 2.4.4.1 EXAMPLE

If including a header file, as in the following directive:

```
#include "myGlobals.h"
```

The header file should be locatable in the current working directory, or the paths specified by any `-I` options, or the standard compiler directories. A header file being located elsewhere does not conform to the CCI.

### 2.4.4.2 DIFFERENCES

The compiler operation under the CCI is not changed. This is purely a coding guideline.

### 2.4.4.3 MIGRATION TO THE CCI

Remove any option that specifies header file search paths other than the `-I` option (or the equivalent MPLAB X IDE option), and use the `-I` option in place of this. Ensure the header file can be found in the directories specified in this section.

## 2.4.5 The Number of Significant Initial Characters in an Identifier

At least the first 255 characters in an identifier (internal and external) are significant. This extends upon the requirement of the ANSI C Standard that states a lower number of significant characters are used to identify an object.

### 2.4.5.1 EXAMPLE

The following example shows two poorly named variables, but names which are considered unique under the CCI.

```
int stateOfPortBWhenTheOperatorHasSelectedAutomaticModeAndMotorIsRunningFast;
int stateOfPortBWhenTheOperatorHasSelectedAutomaticModeAndMotorIsRunningSlow;
```

### 2.4.5.2 DIFFERENCES

Former 8-bit compilers used 31 significant characters by default, but an option allowed this to be extended.

The 16- and 32-bit compilers did not impose a limit on the number of significant characters.

### 2.4.5.3 MIGRATION TO THE CCI

No action required. You can take advantage of the less restrictive naming scheme.

## 2.4.6 Sizes of Types

The sizes of the basic C types, e.g., `char`, `int` and `long`, are *not* fully defined by the CCI. These types, by design, reflect the size of registers and other architectural features in the target device. They allow the device to efficiently access objects of this type. The ANSI C Standard does, however, indicate minimum requirements for these types, as specified in `<limits.h>`.

If you need fixed-size types in your project, use the types defined in `<stdint.h>`, e.g., `uint8_t` or `int16_t`. These types are consistently defined across all XC compilers, even outside of the CCI.

Essentially, the C language offers a choice of two groups of types: those that offer sizes and formats that are tailored to the device you are using, or those that have a fixed size, regardless of the target.

### 2.4.6.1 EXAMPLE

The following example shows the definition of a variable, `native`, whose size will allow efficient access on the target device; and a variable, `fixed`, whose size is clearly indicated and remains fixed, even though it may not allow efficient access on every device.

```
int native;
int16_t fixed;
```

### 2.4.6.2 DIFFERENCES

This is consistent with previous types implemented by the compiler.

### 2.4.6.3 MIGRATION TO THE CCI

If you require a C type that has a fixed size, regardless of the target device, use one of the types defined by `<stdint.h>`.

## 2.4.7 Plain char Types

The type of a plain `char` is `unsigned char`. It is generally recommended that all definitions for the `char` type explicitly state the signedness of the object.

### 2.4.7.1 EXAMPLE

The following example

```
char foobar;
```

defines an `unsigned char` object called `foobar`.

### 2.4.7.2 DIFFERENCES

The 8-bit compilers have always treated plain `char` as an unsigned type.

The 16- and 32-bit compilers used `signed char` as the default plain `char` type. The `-funsigned-char` option on those compilers changed the default type to be `unsigned char`.

### 2.4.7.3 MIGRATION TO THE CCI

Any definition of an object defined as a plain `char` and using the 16- or 32-bit compilers needs review. Any plain `char` that was intended to be a signed quantity should be replaced with an explicit definition, for example.

```
signed char foobar;
```

You can use the `-funsigned-char` option on MPLAB XC16 and XC32 to change the type of plain `char`, but since this option is not supported on MPLAB XC8, the code is not strictly conforming.

## 2.4.8 Signed Integer Representation

The value of a signed integer is determined by taking the two's complement of the integer.

### 2.4.8.1 EXAMPLE

The following shows a variable, `test`, that is assigned the value -28 decimal.

```
signed char test = 0xE4;
```

### 2.4.8.2 DIFFERENCES

All compilers have represented signed integers in the way described in this section.

### 2.4.8.3 MIGRATION TO THE CCI

No action required.

## 2.4.9 Integer Conversion

When converting an integer type to a signed integer of insufficient size, the original value is truncated from the most-significant bit to accommodate the target size.

### 2.4.9.1 EXAMPLE

The following shows an assignment of a value that is truncated.

```
signed char destination;  
unsigned int source = 0x12FE;  
destination = source;
```

Under the CCI, the value of `destination` after the alignment is -2 (i.e., the bit pattern 0xFE).

## 2.4.9.2 DIFFERENCES

All compilers have performed integer conversion in an identical fashion to that described in this section.

## 2.4.9.3 MIGRATION TO THE CCI

No action required.

## 2.4.10 Bitwise Operations on Signed Values

Bitwise operations on signed values act on the two's complement representation, including the sign bit. See also [Section 2.4.11 "Right-shifting Signed Values"](#).

### 2.4.10.1 EXAMPLE

The following shows an example of a negative quantity involved in a bitwise AND operation.

```
signed char output, input = -13;
output = input & 0x7E;
```

Under the CCI, the value of `output` after the assignment is 0x72.

### 2.4.10.2 DIFFERENCES

All compilers have performed bitwise operations in an identical fashion to that described in this section.

### 2.4.10.3 MIGRATION TO THE CCI

No action required.

## 2.4.11 Right-shifting Signed Values

Right-shifting a signed value will involve sign extension. This will preserve the sign of the original value.

### 2.4.11.1 EXAMPLE

The following shows an example of a negative quantity involved in a right-shift operation.

```
signed char output, input = -13;
output = input >> 3;
```

Under the CCI, the value of `output` after the assignment is -2 (i.e., the bit pattern 0xFE).

### 2.4.11.2 DIFFERENCES

All compilers have performed right-shifting as described in this section.

### 2.4.11.3 MIGRATION TO THE CCI

No action required.

## 2.4.12 Conversion of Union Member Accessed Using Member With Different Type

If a union defines several members of different types and you use one member identifier to try to access the contents of another (whether any conversion is applied to the result) is implementation-defined behavior in the standard. In the CCI, no conversion is applied and the bytes of the union object are interpreted as an object of the type of the member being accessed, without regard for alignment or other possible invalid conditions.

### 2.4.12.1 EXAMPLE

The following shows an example of a union defining several members.

```
union {
    signed char code;
    unsigned int data;
    float offset;
} foobar;
```

Code that attempts to extract `offset` by reading `data` is not guaranteed to read the correct value.

```
float result;
result = foobar.data;
```

### 2.4.12.2 DIFFERENCES

All compilers have not converted union members accessed via other members.

### 2.4.12.3 MIGRATION TO THE CCI

No action required.

## 2.4.13 Default Bit-field `int` Type

The type of a bit-field specified as a plain `int` is identical to that of one defined using `unsigned int`. This is quite different from other objects where the types `int`, `signed` and `signed int` are synonymous. It is recommended that the signedness of the bit-field be explicitly stated in all bit-field definitions.

### 2.4.13.1 EXAMPLE

The following shows an example of a structure tag containing bit-fields that are unsigned integers and with the size specified.

```
struct OUTPUTS {
    int direction :1;
    int parity    :3;
    int value     :4;
};
```

### 2.4.13.2 DIFFERENCES

The 8-bit compilers have previously issued a warning if type `int` was used for bit-fields, but would implement the bit-field with an `unsigned int` type.

The 16- and 32-bit compilers have implemented bit-fields defined using `int` as having a `signed int` type, unless the option `-funsigned-bitfields` was specified.



## 2.4.13.3 MIGRATION TO THE CCI

Any code that defines a bit-field with the plain `int` type should be reviewed. If the intention was for these to be signed quantities, then the type of these should be changed to signed `int`. For example, in the following example:

```
struct WAYPT {
    int log          :3;
    int direction    :4;
};
```

the bit-field type should be changed to signed `int`, as in:

```
struct WAYPT {
    signed int log      :3;
    signed int direction :4;
};
```

## 2.4.14 Bit-fields Straddling a Storage Unit Boundary

The standard indicates that implementations can determine whether bit-fields cross a storage unit boundary. In the CCI, bit-fields do not straddle a storage unit boundary; a new storage unit is allocated to the structure, and padding bits fill the gap.

Note that the size of a storage unit differs with each compiler, as this is based on the size of the base data type (e.g., `int`) from which the bit-field type is derived. On 8-bit compilers this unit is 8-bits in size; for 16-bit compilers, it is 16 bits; and for 32-bit compilers, it is 32 bits in size.

### 2.4.14.1 EXAMPLE

The following shows a structure containing bit-fields being defined.

```
struct {
    unsigned first  : 6;
    unsigned second :6;
} order;
```

Under the CCI and using MPLAB XC8, the storage allocation unit is byte sized. The bit-field, `second`, is allocated a new storage unit since there are only 2 bits remaining in the first storage unit in which `first` is allocated. The size of this structure, `order`, is 2 bytes.

### 2.4.14.2 DIFFERENCES

This allocation is identical with that used by all previous compilers.

### 2.4.14.3 MIGRATION TO THE CCI

No action required.

## 2.4.15 The Allocation Order of Bit-fields

The memory ordering of bit-fields into their storage unit is not specified by the ANSI C Standard. In the CCI, the first bit defined is the least significant bit of the storage unit in which it is allocated.

## 2.4.15.1 EXAMPLE

The following shows a structure containing bit-fields being defined.

```
struct {
    unsigned lo  : 1;
    unsigned mid :6;
    unsigned hi  : 1;
} foo;
```

The bit-field `lo` is assigned the least significant bit of the storage unit assigned to the structure `foo`. The bit-field `mid` is assigned the next 6 least significant bits; and `hi`, the most significant bit of that same storage unit byte.

## 2.4.15.2 DIFFERENCES

This is identical with the previous operation of all compilers.

## 2.4.15.3 MIGRATION TO THE CCI

No action required.

## 2.4.16 The NULL Macro

The `NULL` macro is defined by `<stddef.h>`; however, its definition is implementation-defined behavior. Under the CCI, the definition of `NULL` is the expression `(0)`.

### 2.4.16.1 EXAMPLE

The following shows a pointer being assigned a null pointer constant via the `NULL` macro.

```
int * ip = NULL;
```

The value of `NULL`, `(0)`, is implicitly converted to the destination type.

### 2.4.16.2 DIFFERENCES

The 32-bit compilers previously assigned `NULL` the expression `((void *)0)`.

### 2.4.16.3 MIGRATION TO THE CCI

No action required.

## 2.4.17 Floating-point Sizes

Under the CCI, floating-point types must not be smaller than 32 bits in size.

### 2.4.17.1 EXAMPLE

The following shows the definition for `outY`, which is at least 32 bits in size.

```
float outY;
```

### 2.4.17.2 DIFFERENCES

The 8-bit compilers have allowed the use of 24-bit `float` and `double` types.

### 2.4.17.3 MIGRATION TO THE CCI

When using 8-bit compilers, the `float` and `double` type will automatically be made 32 bits in size once the CCI mode is enabled. Review any source code that may have assumed a `float` or `double` type and may have been 24 bits in size.

No migration is required for other compilers.

## 2.5 ANSI STANDARD EXTENSIONS

The following topics describe how the CCI provides device-specific extensions to the standard.

### 2.5.1 Generic Header File

A single header file `<xc.h>` must be used to declare all compiler- and device-specific types and SFRs. You *must* include this file into every module to conform with the CCI. Some CCI definitions depend on this header being seen.

#### 2.5.1.1 EXAMPLE

The following shows this header file being included, thus allowing conformance with the CCI, as well as allowing access to SFRs.

```
#include <xc.h>
```

#### 2.5.1.2 DIFFERENCES

Some 8-bit compilers used `<htc.h>` as the equivalent header. Previous versions of the 16- and 32-bit compilers used a variety of headers to do the same job.

#### 2.5.1.3 MIGRATION TO THE CCI

Change:

```
#include <htc.h>
```

previously used in 8-bit compiler code, or family-specific header files, e.g., from:

```
#include <p32xxxx.h>
#include <p30fxxxx.h>
#include <p33Fxxxx.h>
#include <p24Fxxxx.h>
#include "p30f6014.h"
```

to:

```
#include <xc.h>
```

### 2.5.2 Absolute Addressing

Variables and functions can be placed at an absolute address by using the `__at()` construct. Stack-based (`auto` and parameter) variables cannot use the `__at()` specifier.

#### 2.5.2.1 EXAMPLE

The following shows two variables and a function being made absolute.

```
int scanMode __at(0x200);
const char keys[] __at(124) = { 'r', 's', 'u', 'd' };

__at(0x1000) int modify(int x) {
    return x * 2 + 3;
}
```

#### 2.5.2.2 DIFFERENCES

The 8-bit compilers have used an `@` symbol to specify an absolute address.

The 16- and 32-bit compilers have used the `address` attribute to specify an object's address.

## 2.5.2.3 MIGRATION TO THE CCI

Avoid making objects and functions absolute if possible.

In MPLAB XC8, change absolute object definitions, e.g., from:

```
int scanMode @ 0x200;
```

to:

```
int scanMode __at(0x200);
```

In MPLAB XC16 and XC32, change code, e.g., from:

```
int scanMode __attribute__((address(0x200)));
```

to:

```
int scanMode __at(0x200);
```

## 2.5.2.4 CAVEATS

If the `__at()` and `__section()` specifiers are both applied to an object when using MPLAB XC8, the `__section()` specifier is currently ignored.

The `__at()` specifier must be placed at the beginning of function prototypes for the 16- and 32-bit compilers. If you prefer to use the specifier at the end of the prototype, use the specifier with a declaration and leave it off the definition, for example:

```
int modify(int x) __at(0x1000);  
int modify(int x)  
{ ... }
```

## 2.5.3 Far Objects and Functions

The `__far` qualifier can be used to indicate that variables or functions are located in 'far memory'. Exactly what constitutes far memory is dependent on the target device, but it is typically memory that requires more complex code to access. Expressions involving far-qualified objects usually generate slower and larger code.

Use the native keywords discussed in the Differences section to look up information on the semantics of this qualifier.

Some devices may not have such memory implemented; in which case, use of this qualifier is ignored. Stack-based (`auto` and parameter) variables cannot use the `__far` specifier.

### 2.5.3.1 EXAMPLE

The following shows a variable and function qualified using `__far`.

```
__far int serialNo;  
__far int ext_getCond(int selector);
```

### 2.5.3.2 DIFFERENCES

The 8-bit compilers have used the qualifier `far` to indicate this meaning. Functions could not be qualified as `far`.

The 16-bit compilers have used the `far` attribute with both variables and functions.

The 32-bit compilers have used the `far` attribute with functions, only.

## 2.5.3.3 MIGRATION TO THE CCI

For 8-bit compilers, change any occurrence of the `far` qualifier, e.g., from:

```
far char template[20];
```

to:

```
__far, i.e., __far char template[20];
```

In the 16- and 32-bit compilers, change any occurrence of the `far` attribute, e.g., from:

```
void bar(void) __attribute__((far));  
int tblIdx __attribute__((far));
```

to:

```
void __far bar(void);  
int __far tblIdx;
```

## 2.5.3.4 CAVEATS

None.

## 2.5.4 Near Objects

The `__near` qualifier can be used to indicate that variables or functions are located in 'near memory'. Exactly what constitutes near memory is dependent on the target device, but it is typically memory that can be accessed with less complex code. Expressions involving near-qualified objects generally are faster and result in smaller code.

Use the native keywords discussed in the Differences section to look up information on the semantics of this qualifier.

Some devices may not have such memory implemented; in which case, use of this qualifier is ignored. Stack-based (`auto` and `parameter`) variables cannot use the `__near` specifier.

### 2.5.4.1 EXAMPLE

The following shows a variable and function qualified using `__near`.

```
__near int serialNo;  
__near int ext_getCond(int selector);
```

### 2.5.4.2 DIFFERENCES

The 8-bit compilers have used the qualifier `near` to indicate this meaning. Functions could not be qualified as `near`.

The 16-bit compilers have used the `near` attribute with both variables and functions.

The 32-bit compilers have used the `near` attribute for functions, only.

## 2.5.4.3 MIGRATION TO THE CCI

For 8-bit compilers, change any occurrence of the `near` qualifier to `__near`, e.g., from:

```
near char template[20];
```

to:

```
__near char template[20];
```

In 16- and 32-bit compilers, change any occurrence of the `near` attribute to `__near`, e.g., from:

```
void bar(void) __attribute__((near));  
int tblIdx __attribute__((near));
```

to:

```
void __near bar(void);  
int __near tblIdx;
```

## 2.5.4.4 CAVEATS

None.

## 2.5.5 Persistent Objects

The `__persistent` qualifier can be used to indicate that variables should not be cleared by the runtime startup code.

Use the native keywords discussed in the Differences section to look up information on the semantics of this qualifier.

### 2.5.5.1 EXAMPLE

The following shows a variable qualified using `__persistent`.

```
__persistent int serialNo;
```

### 2.5.5.2 DIFFERENCES

The 8-bit compilers have used the qualifier, `persistent`, to indicate this meaning.

The 16- and 32-bit compilers have used the `persistent` attribute with variables to indicate they were not to be cleared.

### 2.5.5.3 MIGRATION TO THE CCI

With 8-bit compilers, change any occurrence of the `persistent` qualifier to `__persistent`, e.g., from:

```
persistent char template[20];
```

to:

```
__persistent char template[20];
```

For the 16- and 32-bit compilers, change any occurrence of the `persistent` attribute to `__persistent`, e.g., from:

```
int tblIdx __attribute__((persistent));
```

to:

```
int __persistent tblIdx;
```

### 2.5.5.4 CAVEATS

None.

## 2.5.6 X and Y Data Objects

The `__xdata` and `__ydata` qualifiers can be used to indicate that variables are located in special memory regions. Exactly what constitutes X and Y memory is dependent on the target device, but it is typically memory that can be accessed independently on separate buses. Such memory is often required for some DSP instructions.

Use the native keywords discussed in the "Differences" section to look up information on the semantics of these qualifiers.

Some devices may not have such memory implemented; in which case, use of these qualifiers is ignored.

### 2.5.6.1 EXAMPLE

The following shows a variable qualified using `__xdata`, as well as another variable qualified with `__ydata`.

```
__xdata char data[16];  
__ydata char coeffs[4];
```

### 2.5.6.2 DIFFERENCES

The 16-bit compilers have used the `xmemory` and `ymemory` space attribute with variables.

Equivalent specifiers have never been defined for any other compiler.

### 2.5.6.3 MIGRATION TO THE CCI

For 16-bit compilers, change any occurrence of the `space` attributes `xmemory` or `ymemory` to `__xdata`, or `__ydata` respectively, e.g., from:

```
char __attribute__((space(xmemory))) template[20];
```

to:

```
__xdata char template[20];
```

### 2.5.6.4 CAVEATS

None.

## 2.5.7 Banked Data Objects

The `__bank(num)` qualifier can be used to indicate that variables are located in a particular data memory bank. The number, `num`, represents the bank number. Exactly what constitutes banked memory is dependent on the target device, but it is typically a subdivision of data memory to allow for assembly instructions with a limited address width field.

Use the native keywords discussed in the Differences section to look up information on the semantics of these qualifiers.

Some devices may not have banked data memory implemented; in which case, use of this qualifier is ignored. The number of data banks implemented will vary from one device to another.

### 2.5.7.1 EXAMPLE

The following shows a variable qualified using `__bank()`.

```
__bank(0) char start;  
__bank(5) char stop;
```

## 2.5.7.2 DIFFERENCES

The 8-bit compilers have used the four qualifiers `bank0`, `bank1`, `bank2` and `bank3` to indicate the same, albeit more limited, memory placement.

Equivalent specifiers have never been defined for any other compiler.

## 2.5.7.3 MIGRATION TO THE CCI

For 8-bit compilers, change any occurrence of the `bankx` qualifiers to `__bank()`, e.g., from:

```
bank2 int logEntry;
```

to:

```
__bank(2) int logEntry;
```

## 2.5.7.4 CAVEATS

This feature is not yet implemented in MPLAB XC8.

## 2.5.8 Alignment of Objects

The `__align(alignment)` specifier can be used to indicate that variables must be aligned on a memory address that is a multiple of the alignment specified. The alignment term must be a power of 2. Positive values request that the object's start address be aligned; negative values imply the object's end address be aligned.

Use the native keywords discussed in the Differences section to look up information on the semantics of this specifier.

### 2.5.8.1 EXAMPLE

The following shows variables qualified using `__align()` to ensure they end on an address that is a multiple of 8, and start on an address that is a multiple of 2, respectively.

```
__align(-8) int spacer;  
__align(2) char coeffs[6];
```

### 2.5.8.2 DIFFERENCES

An alignment feature has never been implemented on 8-bit compilers.

The 16- and 32-bit compilers used the `aligned` attribute with variables.

### 2.5.8.3 MIGRATION TO THE CCI

For 16- and 32-bit compilers, change any occurrence of the `aligned` attribute to `__align`, e.g., from:

```
char __attribute__((aligned(4))) mode;
```

to:

```
__align(4) char mode;
```

### 2.5.8.4 CAVEATS

This feature is not yet implemented on MPLAB XC8.



## 2.5.9 EEPROM Objects

The `__eeprom` qualifier can be used to indicate that variables should be positioned in EEPROM.

Use the native keywords discussed in the Differences section to look up information on the semantics of this qualifier.

Some devices may not implement EEPROM. Use of this qualifier for such devices generates a warning. Stack-based (`auto` and `parameter`) variables cannot use the `__eeprom` specifier.

### 2.5.9.1 EXAMPLE

The following shows a variable qualified using `__eeprom`.

```
__eeprom int serialNos[4];
```

### 2.5.9.2 DIFFERENCES

The 8-bit compilers have used the qualifier, `eeprom`, to indicate this meaning for some devices.

The 16-bit compilers have used the `space` attribute to allocate variables to the memory space used for EEPROM.

### 2.5.9.3 MIGRATION TO THE CCI

For 8-bit compilers, change any occurrence of the `eeprom` qualifier to `__eeprom`, e.g., from:

```
eeprom char title[20];
```

to:

```
__eeprom char title[20];
```

For 16-bit compilers, change any occurrence of the `eedata space` attribute to `__eeprom`, e.g., from:

```
int mainSw __attribute__ ((space(eedata)));
```

to:

```
int __eeprom mainSw;
```

### 2.5.9.4 CAVEATS

MPLAB XC8 does not implement the `__eeprom` qualifiers for any PIC18 devices; this qualifier works as expected for other 8-bit devices.

## 2.5.10 Interrupt Functions

The `__interrupt (type)` specifier can be used to indicate that a function is to act as an interrupt service routine. The `type` is a comma-separated list of keywords that indicate information about the interrupt function.

The current interrupt types are:

<b>&lt;empty&gt;</b>	Implement the default interrupt function.
<b>low_priority</b>	The interrupt function corresponds to the low priority interrupt source. (MPLAB XC8 - PIC18 only)
<b>high_priority</b>	The interrupt function corresponds to the high priority interrupt source. (MPLAB XC8)
<b>save(symbol-list)</b>	Save the listed symbols on entry, and restore on exit. (MPLAB XC16)
<b>irq(irqid)</b>	Specify the interrupt vector associated with this interrupt. (MPLAB XC16 and XC8)
<b>altirq(altirqid)</b>	Specify the alternate interrupt vector associated with this interrupt. (MPLAB XC16)
<b>base(address)</b>	Specify vector table address. (MPLAB XC8)
<b>preprologue(asm)</b>	Specify assembly code to be executed before any compiler-generated interrupt code. (MPLAB XC16)
<b>shadow</b>	Allow the ISR to utilize the shadow registers for context switching. (MPLAB XC16)
<b>auto_psv</b>	The ISR will set the PSVPAG register and restore it on exit. (MPLAB XC16)
<b>no_auto_psv</b>	The ISR will not set the PSVPAG register. (MPLAB XC16)

Use the native keywords discussed in the Differences section to look up information on the semantics of this specifier.

Some devices may not implement interrupts. Use of this qualifier for such devices generates a warning. If the argument to the `__interrupt` specifier does not make sense for the target device, a warning or error is issued by the compiler.

### 2.5.10.1 EXAMPLE

The following shows a function qualified using `__interrupt`.

```
__interrupt(low_priority) void getData(void) {  
    if (TMR0IE && TMR0IF) {  
        TMR0IF=0;  
        ++tick_count;  
    }  
}
```

## 2.5.10.2 DIFFERENCES

The 8-bit compilers have used the `interrupt` and `low_priority` qualifiers to indicate this meaning for some devices. Interrupt routines were, by default, high priority. The `__interrupt()` specifier may now be used outside of the CCI.

The 16- and 32-bit compilers have used the `interrupt` attribute to define interrupt functions.

## 2.5.10.3 MIGRATION TO THE CCI

For 8-bit compilers, change any occurrence of the `interrupt` qualifier, e.g., from:

```
void interrupt myIsr(void)
void interrupt low_priority myLoIsr(void)
```

to the following, respectively:

```
void __interrupt(high_priority) myIsr(void)
void __interrupt(low_priority) myLoIsr(void)
```

For 16-bit compilers, change any occurrence of the `interrupt` attribute, e.g., from:

```
void __attribute__((interrupt(auto_psv, irq(52))))
_T1Interrupt(void);
```

to:

```
void __interrupt(auto_psv, irq(52)) _T1Interrupt(void);
```

For 32-bit compilers, the `__interrupt()` keyword takes two parameters, the vector number and the (optional) IPL value. Change code that uses the `interrupt` attribute, similar to these examples:

```
void __attribute__((vector(0), interrupt(IPL7AUTO), nomips16))
myIsr0_7A(void) {}
```

```
void __attribute__((vector(1), interrupt(IPL6SRS), nomips16))
myIsr1_6SRS(void) {}
```

```
/* Determine IPL and context-saving mode at runtime */
void __attribute__((vector(2), interrupt(), nomips16))
myIsr2_RUNTIME(void) {}
```

to:

```
void __interrupt(0, IPL7AUTO) myIsr0_7A(void) {}
```

```
void __interrupt(1, IPL6SRS) myIsr1_6SRS(void) {}
```

```
/* Determine IPL and context-saving mode at runtime */
void __interrupt(2) myIsr2_RUNTIME(void) {}
```

## 2.5.10.4 CAVEATS

None.

## 2.5.11 Packing Objects

The `__pack` specifier can be used to indicate that structures should not use memory gaps to align structure members, or that individual structure members should not be aligned.

Use the native keywords discussed in the Differences section to look up information on the semantics of this specifier.

Some compilers cannot pad structures with alignment gaps for some devices, and use of this specifier for such devices is ignored.

### 2.5.11.1 EXAMPLE

The following shows a structure qualified using `__pack`, as well as a structure where one member has been explicitly packed.

```
__pack struct DATAPOINT {
    unsigned char type;
    int value;
} x-point;
struct LINETYPE {
    unsigned char type;
    __pack int start;
    long total;
} line;
```

### 2.5.11.2 DIFFERENCES

The `__pack` specifier is a new CCI specifier that is available with MPLAB XC8. This specifier has no apparent effect since the device memory is byte addressable for all data objects.

The 16- and 32-bit compilers have used the `packed` attribute to indicate that a structure member was not aligned with a memory gap.

### 2.5.11.3 MIGRATION TO THE CCI

No migration is required for MPLAB XC8.

For 16- and 32-bit compilers, change any occurrence of the `packed` attribute, e.g., from:

```
struct DOT
{
    char a;
    int x[2] __attribute__((packed));
};
```

to:

```
struct DOT
{
    char a;
    __pack int x[2];
};
```

Alternatively, you can pack the entire structure, if required.

### 2.5.11.4 CAVEATS

None.

## 2.5.12 Indicating Antiquated Objects

The `__deprecated` specifier can be used to indicate that an object has limited longevity and should not be used in new designs. It is commonly used by the compiler vendor to indicate that compiler extensions or features can become obsolete, or that better features have been developed and should be used in preference.

Use the native keywords discussed in the Differences section to look up information on the semantics of this specifier.

### 2.5.12.1 EXAMPLE

The following shows a function that uses the `__deprecated` keyword.

```
void __deprecated getValue(int mode)
{
    //...
}
```

### 2.5.12.2 DIFFERENCES

No deprecated feature was implemented on 8-bit compilers.

The 16- and 32-bit compilers have used the `deprecated` attribute (note the different spelling) to indicate that objects should be avoided, if possible.

### 2.5.12.3 MIGRATION TO THE CCI

For 16- and 32-bit compilers, change any occurrence of the `deprecated` attribute to `__deprecated`, e.g., from:

```
int __attribute__((deprecated)) intMask;
```

to:

```
int __deprecated intMask;
```

### 2.5.12.4 CAVEATS

None.

## 2.5.13 Assigning Objects to Sections

The `__section()` specifier can be used to indicate that an object should be located in the named section (or `psect`, using MPLAB XC8 terminology). This is typically used when the object has special and unique linking requirements that cannot be addressed by existing compiler features.

Use the native keywords discussed in the Differences section to look up information on the semantics of this specifier.

### 2.5.13.1 EXAMPLE

The following shows a variable which uses the `__section` keyword.

```
int __section("comSec") commonFlag;
```

### 2.5.13.2 DIFFERENCES

The 8-bit compilers have previously used the `#pragma psect` directive to redirect objects to a new section, or `psect`; however, the `__section()` specifier is the preferred method to perform this task, even if you are not using the CCI.

The 16- and 32-bit compilers have used the `section` attribute to indicate a different destination section name. The `__section()` specifier works in a similar way to the attribute.

## 2.5.13.3 MIGRATION TO THE CCI

For MPLAB XC8, change any occurrence of the `#pragma psect` directive, such as:

```
#pragma psect text%%u=myText
int getMode(int target) {
//...
}
```

to the `__section()` specifier, as in:

```
int __section("myText") getMode(int target) {
//...
}
```

For 16- and 32-bit compilers, change any occurrence of the `section` attribute, e.g., from:

```
int __attribute__((section("myVars"))) intMask;
```

to:

```
int __section("myVars") intMask;
```

## 2.5.13.4 CAVEATS

None.

## 2.5.14 Specifying Configuration Bits

The `#pragma config` directive can be used to program the Configuration bits for a device. The pragma has the form:

```
#pragma config setting = state|value
```

where *setting* is a configuration setting descriptor (e.g., WDT), *state* is a descriptive value (e.g., ON) and *value* is a numerical value.

Use the native keywords discussed in the Differences section to look up information on the semantics of this directive.

### 2.5.14.1 EXAMPLE

The following shows Configuration bits being specified using this pragma.

```
#pragma config WDT=ON, WDTPS = 0x1A
```

### 2.5.14.2 DIFFERENCES

The 8-bit compilers have used the `__CONFIG()` macro for some targets that did not already have support for the `#pragma config`.

The 16-bit compilers have used a number of macros to specify the configuration settings.

The 32-bit compilers supported the use of `#pragma config`.

## 2.5.14.3 MIGRATION TO THE CCI

For the 8-bit compilers, change any occurrence of the `__CONFIG()` macro, e.g.,

```
__CONFIG(WDTEN & XT & DPROT)
```

to the `#pragma config` directive, e.g.,

```
#pragma config WDTE=ON, FOSC=XT, CPD=ON
```

No migration is required if the `#pragma config` was already used.

For the 16-bit compilers, change any occurrence of the `_FOSC()` or `_FBORPOR()` macros attribute, e.g., from:

```
_FOSC(CSW_FSCM_ON & EC_PLL16);
```

to:

```
#pragma config FCKSMEM = CSW_ON_FSCM_ON, FPR = ECIO_PLL16
```

No migration is required for 32-bit code.

## 2.5.14.4 CAVEATS

None.

## 2.5.15 Manifest Macros

The CCI defines the general form for macros that manifest the compiler and target device characteristics. These macros can be used to conditionally compile alternate source code based on the compiler or the target device.

The macros and macro families are details in [Table 2-1](#).

**TABLE 2-1: MANIFEST MACROS DEFINED BY THE CCI**

Name	Meaning if defined	Example
<code>__XC__</code>	Compiled with an MPLAB XC compiler	<code>__XC__</code>
<code>__CCI__</code>	Compiler is CCI compliant and CCI enforcement is enabled	<code>__CCI__</code>
<code>__XC##__</code>	The specific XC compiler used (## can be 8, 16 or 32)	<code>__XC8__</code>
<code>__DEVICEFAMILY__</code>	The family of the selected target device	<code>__dsPIC30F__</code>
<code>__DEVICENAME__</code>	The selected target device name	<code>__18F452__</code>

### 2.5.15.1 EXAMPLE

The following shows code that is conditionally compiled dependent on the device having EEPROM memory.

```
#ifdef __XC16__
void __interrupt(__auto_psv__) myIsr(void)
#else
void __interrupt(low_priority) myIsr(void)
#endif
```

### 2.5.15.2 DIFFERENCES

Some of these CCI macros are new (for example `__CCI__`), and others have different names to previous symbols with identical meaning (e.g., `__18F452` is now `__18F452__`).

## 2.5.15.3 MIGRATION TO THE CCI

Any code that uses compiler-defined macros needs review. Old macros will continue to work as expected, but they are not compliant with the CCI.

## 2.5.15.4 CAVEATS

None.

## 2.5.16 In-line Assembly

The `asm()` statement can be used to insert assembly code in-line with C code. The argument is a C string literal that represents a single assembly instruction. Obviously, the instructions contained in the argument are device specific.

Use the native keywords discussed in the Differences section to look up information on the semantics of this statement.

### 2.5.16.1 EXAMPLE

The following shows a `MOVLW` instruction being inserted in-line.

```
asm("MOVLW _foobar");
```

### 2.5.16.2 DIFFERENCES

The 8-bit compilers have used either the `asm()` or `#asm ... #endasm` constructs to insert in-line assembly code.

This is the same syntax used by the 16- and 32-bit compilers.

### 2.5.16.3 MIGRATION TO THE CCI

For 8-bit compilers, change any instance of `#asm ... #endasm`, so that each instruction in the `#asm` block is placed in its own `asm()` statement, e.g., from:

```
#asm
    MOVLW  20
    MOVWF  _i
    CLRF   Ii+1
#endasm
```

to:

```
asm("MOVLW20");
asm("MOVWF _i");
asm("CLRFIi+1");
```

No migration is required for the 16- or 32-bit compilers.

### 2.5.16.4 CAVEATS

None.



## 2.6 COMPILER FEATURES

The following item details the compiler options used to control the CCI.

### 2.6.1 Enabling the CCI

It is assumed that you are using the MPLAB X IDE to build projects that use the CCI. The widget in the MPLAB X IDE Project Properties to enable CCI conformance is Use CCI Syntax in the Compiler category.

If you are not using this IDE, then the command-line options are `--EXT=cci` for MPLAB XC8 or `-mcci` for MPLAB XC16 and XC32.

#### 2.6.1.1 DIFFERENCES

This option has never been implemented previously.

#### 2.6.1.2 MIGRATION TO THE CCI

Enable the option.

#### 2.6.1.3 CAVEATS

None.

# MPLAB® XC8 C Compiler User's Guide

---

NOTES:

---

---

## Chapter 3. How To's

---

---

### 3.1 INTRODUCTION

This section contains help and references for situations that are frequently encountered when building projects for Microchip 8-bit devices. Click the links at the beginning of each section to assist in finding the topic relevant to your question. Some topics are indexed in multiple sections.

Start here:

- [Installing and Activating the Compiler](#)
- [Invoking the Compiler](#)
- [Writing Source Code](#)
- [Getting My Application to Do What I Want](#)
- [Understanding the Compilation Process](#)
- [Fixing Code That Does Not Work](#)

### 3.2 INSTALLING AND ACTIVATING THE COMPILER

This section details questions that might arise when installing or activating the compiler.

- [How Do I Install and Activate My Compiler?](#)
- [How Can I Tell if the Compiler has Activated Successfully?](#)
- [Can I Install More Than One Version of the Same Compiler?](#)

#### 3.2.1 How Do I Install and Activate My Compiler?

Installation of the compiler and activation of the license are performed simultaneously by the XC compiler installer. The guide *Installing and Licensing MPLAB XC C Compilers* (DS52059) is available on [www.microchip.com/compilers](http://www.microchip.com/compilers), under the Documentation tab. It provides details on single-user and network licenses, as well as how to activate a compiler for evaluation purposes.

#### 3.2.2 How Can I Tell if the Compiler has Activated Successfully?

If you think the compiler cannot have installed correctly or is not working, it is best to verify its operation outside of MPLAB X IDE to isolate possible problems.

The `xclm` application can be queried to determine the status of your compiler. From your terminal or DOS-prompt, type the following line.

```
"C:\Program Files\Microchip\xc8\v1.00\bin\xclm" -status
```

## 3.2.3 Can I Install More Than One Version of the Same Compiler?

Yes, the compilers and installation process has been designed to allow you to have more than one version of the same compiler installed, and you can easily move between the versions by changing options in MPLAB X IDE; see [Section 3.3.4 “How Can I Select Which Compiler I Want to Build With?”](#).

Compilers should be installed into a directory whose name is related to the compiler version. This is reflected in the default directory specified by the installer. For example, the 1.00 and 1.10 MPLAB XC8 compilers would typically be placed in separate directories.

```
C:\Program Files\Microchip\xc8\v1.00\
```

```
C:\Program Files\Microchip\xc8\v1.10\
```

## 3.3 INVOKING THE COMPILER

This section discusses how the compiler is run, on the command-line or from the MPLAB X IDE. It includes information about how to get the compiler to do what you want it to do, in terms of options and the build process itself.

- [How Do I Compile From Within MPLAB X IDE?](#)
- [How Do I Compile on the Command-line?](#)
- [How Do I Compile Using a Make Utility?](#)
- [How Can I Select Which Compiler I Want to Build With?](#)
- [How Can I Change the Compiler's Operating Mode?](#)
- [How Do I Build Libraries?](#)
- [How Do I Know What Compiler Options Are Available and What They Do?](#)
- [How Do I Know What the Build Options in MPLAB X IDE Do?](#)
- [What is Different About an MPLAB X IDE Debug Build?](#)

See, also, the following linked information in other sections.

- [What Do I Need to Do When Compiling to Use a Debugger?](#)
- [How Do I Use Library Files in My Project?](#)
- [How Do I Place a Function Into a Unique Section?](#)
- [What Optimizations Are Employed by the Compiler?](#)

### 3.3.1 How Do I Compile From Within MPLAB X IDE?

MPLAB X IDE User's Guide and online help provide directions for setting up a project in the MPLAB X integrated development environment.

Alternatively, download the *MPLAB<sup>®</sup> XC8 User's Guide for Embedded Engineers* (DS50002400) or open the *MPLAB<sup>®</sup> XC8 Getting Started Guide* (DS50002173) from the compiler's docs directory.

### 3.3.2 How Do I Compile on the Command-line?

The compiler driver is called `xc8` for all 8-bit PIC devices; e.g., in Windows, it is named `xc8.exe`. This application should be invoked for all aspects of compilation. It is located in the `bin` directory of the compiler distribution. Avoid running the individual compiler applications (such as the assembler or linker) explicitly. You can compile and link in the one command, even if your project is spread among multiple source files.

The driver is introduced in [Section 4.2 "Invoking the Compiler"](#). See [Section 3.3.4 "How Can I Select Which Compiler I Want to Build With?"](#), to ensure you are running the correct driver if you have more than one installed. The command-line options to the driver are detailed in [Section 4.7 "MPLAB XC8 Driver Options"](#). The files that can be passed to the driver are listed and described in [Section 4.2.3 "Input File Types"](#).

### 3.3.3 How Do I Compile Using a Make Utility?

When compiling using a make utility (such as `make`), the compilation is usually performed as a two-step process: first generating the intermediate files, then the final compilation and link step to produce one binary output. This is described in [Section 4.3.3 "Multi-Step Compilation"](#).

The MPLAB XC8 compiler uses a unique technology called OCG that uses an intermediate file format that is different than traditional compilers (including XC16 and XC32). The intermediate file format used by XC8 is a p-code file (`.p1` extension), not an object file. Generating object files as an intermediate file for multi-step compilation defeats many of the advantages of this technology.

## 3.3.4 How Can I Select Which Compiler I Want to Build With?

The compilation and installation process has been designed to allow you to have more than one compiler installed at the same time. You can create a project in MPLAB X IDE and then build this project with different compilers by simply changing a setting in the project properties.

To select which compiler is actually used when building a project under MPLAB X IDE, go to the Project Properties dialog. Select the Configuration category in the Project Properties dialog (Conf: [default]). A list of MPLAB XC8 compilers is shown in the Compiler Toolchain, on the far right. Select the compiler that you require.

Once selected, the controls for that compiler are then shown by selecting the MPLAB XC8 global options, MPLAB XC8 Compiler and MPLAB XC8 Linker categories. These reveal a pane of options on the right. Note that each category has several panes which can be selected from a pull-down menu that is near the top of the pane.

## 3.3.5 How Can I Change the Compiler's Operating Mode?

The compiler's operating mode (Free, Standard or PRO, see [Section 1.2 "Compiler Description and Documentation"](#)) can be specified as a command line option when building on the command line; see [Section 4.8.39 "--MODE: Choose Compiler Operating Mode"](#). If you are building under MPLAB X IDE, there is a Project Properties selector in the XC8 Compiler category, under the Optimizations option selector; see [Section 4.9.2 "Compiler Category"](#).

You can only select modes that your license entitles you to use. The Free mode is always available; Standard or PRO can be selected if you have purchased a license for those modes.

## 3.3.6 How Do I Build Libraries?

Note that XC8 uses a different code generation framework (OCG) that uses additional library files to those used by traditional compilers (including XC16 and XC32). See [Section 4.3.1 "The Compiler Applications"](#), for general information on the library types available and how they fit into the compilation process.

When you have functions and data that are commonly used in applications, you can either make all the C source and header files available so that other developers can copy these into their projects. Alternatively you can bundle these source files up into a library which, along with the accompanying header files, can be linked into a project.

Libraries are more convenient because there are fewer files to deal with. Compiling code from a library can also be fractionally faster. However, libraries do need to be maintained. XC8 must use LPP libraries for library routines written in C; the old-style LIB libraries are used for library routines written in assembly source. It is recommended that even these libraries be rebuilt if your project is moving to a new compiler version.

Using the compiler driver, libraries can be built by listing all of the files that are to be included into the library on the command line. None of these files should contain a `main()` function, nor settings for Configuration bits or any other such data. Use the `--OUTPUT=lpp` option; see [Section 4.8.47 "--OUTPUT= type: Specify Output File Type"](#), to indicate that a library file is required. For example:

```
XC8 --chip=16f877a --output=lpp lcd.c utils.c io.c
```

creates a library file called `lcd.lpp`. You can specify another name using the `-O` option; see [Section 4.8.9 "-O: Specify Output File"](#), or just rename the file.

To build a library in MPLAB X IDE, create a regular project.<sup>1</sup> Add your source files in the usual way. Add in the option `--OUTPUT=lpp` to the Additional Options field in the MPLAB XC8 Linker category. Click **Build**. The IDE will issue a warning about the HEX file being missing, but this can be ignored. The library output can be found in the `dist/default/production` folder of the project directory.

Note that if you intend to step through your library code at a C level in MPLAB X IDE, you will need to place the library source files so that the relative path between their location and the project that is using them is the same as the relative path between where the library build command was executed and where the source files were located when they were built.

### 3.3.7 How Do I Know What Compiler Options Are Available and What They Do?

A list of all compiler options can be obtained by using the `--HELP` option on the command line; see [Section 4.8.34 "--HELP: Display Help"](#). If you give the `--HELP` option an argument, being an option name, it will give specific information on that option, for example `--HELP=runtime`.

Alternatively, all options are all listed in [Section 4.8 "Option Descriptions"](#) in this user's guide. If you are compiling in MPLAB X IDE, see [Section 4.9 "MPLAB X Option Equivalents"](#).

### 3.3.8 How Do I Know What the Build Options in MPLAB X IDE Do?

Each of the widgets and controls, in the MPLAB X IDE Project Properties, map directly to one command-line driver option or suboption, in most instances. [Section 4.8 "Option Descriptions"](#) in this user's guide lists all command-line driver options and includes cross references, where appropriate, to corresponding sections that relate to accessing those options from the IDE. (see [Section 4.9 "MPLAB X Option Equivalents"](#)).

### 3.3.9 What is Different About an MPLAB X IDE Debug Build?

In MPLAB X, there are distinct build buttons and menu items to build (production) a project and to debug a project.

While there are many differences between the builds in the IDE – in the XC8 compiler, there is very little that is different between the two types of build. The main difference is the setting of a preprocessor macro called `__DEBUG`, which is assigned 1 when a performing a debug build. This macro is not defined for production builds.

You can make code in your source conditional on this macro using `#ifdef` directives, etc., (see [Section 5.14.2 "Preprocessor Directives"](#)); so that you can have your program behave differently when you are still in a development cycle. Some compiler errors are easier to track down after performing a debug build.

In MPLAB X IDE, memory is reserved for your debugger (if selected) only when you perform a debug build. See [Section 3.5.4 "What Do I Need to Do When Compiling to Use a Debugger?"](#) for more information.

---

1. At present, the IDE library projects are incompatible with MPLAB XC8.

## 3.4 WRITING SOURCE CODE

This section presents issues that pertain to the source code you write. It has been subdivided into the sections listed below.

- [C Language Specifics](#)
- [Device-Specific Features](#)
- [Memory Allocation](#)
- [Variables](#)
- [Functions](#)
- [Interrupts](#)
- [Assembly Code](#)

### 3.4.1 C Language Specifics

This section discusses source code issues that directly relate to the C language itself, but are commonly asked.

- [When Should I Cast Expressions?](#)
- [Can Implicit Type Conversions Change the Expected Results of My Expressions?](#)
- [How Do I Enter Non-English Characters Into My Program?](#)
- [How Can I Use a Variable Defined in Another Source File?](#)

#### 3.4.1.1 WHEN SHOULD I CAST EXPRESSIONS?

Expressions can be explicitly cast using the cast operator -- a type in round brackets, e.g., `(int)`. In all cases, conversion of one type to another must be done with caution and only when absolutely necessary.

Consider the example:

```
unsigned long l;  
unsigned int i;  
  
i = l;
```

Here, a `long` type is being assigned to an `int` type, and the assignment will truncate the value in `l`. The compiler will automatically perform a type conversion from the type of the expression on the right of the assignment operator (`long`) to the type of the lvalue on the left of the operator (`int`). This is called an implicit type conversion. The compiler typically produces a warning concerning the potential loss of data by the truncation.

A cast to type `int` is not required and should not be used in the above example if a `long` to `int` conversion was intended. The compiler knows the types of both operands and performs the conversion accordingly. If you did use a cast, there is the potential for mistakes if the code is later changed. For example, if you had:

```
i = (int)l;
```

the code works the same way; but if, in future, the type of `i` is changed to a `long`, for example, then you must remember to adjust the cast, or remove it, otherwise the contents of `l` will continue to be truncated by the assignment, which cannot be correct. Most importantly, the warning issued by the compiler will not be produced if the cast is in place.



Only use a cast in situations where the types used by the compiler are not the types that you require. For example, consider the result of a division assigned to a floating point variable:

```
int i, j;
float fl;

fl = i/j;
```

In this case, integer division is performed, then the rounded integer result is converted to a `float` format. So, if `i` contained 7 and `j` contained 2, the division yields 3 and this is implicitly converted to a `float` type (3.0) and then assigned to `fl`. If you wanted the division to be performed in a `float` format, then a cast is necessary:

```
fl = (float)i/j;
```

(Casting either `i` or `j` forces the compiler to encode a floating-point division.) The result assigned to `fl` now is 3.5.

An explicit cast can suppress warnings that might otherwise have been produced. This can also be the source of many problems. The more warnings the compiler produces, the better chance you have of finding potential bugs in your code.

### 3.4.1.2 CAN IMPLICIT TYPE CONVERSIONS CHANGE THE EXPECTED RESULTS OF MY EXPRESSIONS?

Yes! The compiler will always use integral promotion and there is no way to disable this; see [Section 5.6.1 “Integral Promotion”](#). In addition, the types of operands to binary operators are usually changed so that they have a common type, as specified by the C Standard. Changing the type of an operand can change the value of the final expression, so it is very important that you understand the type C Standard conversion rules that apply when dealing with binary operators. You can manually change the type of an operand by casting; see [Section 3.4.1.1 “When Should I Cast Expressions?”](#).

### 3.4.1.3 HOW DO I ENTER NON-ENGLISH CHARACTERS INTO MY PROGRAM?

The ANSI standard (and accordingly, the MPLAB XC8 C compiler) does not support extended characters set in character and string literals in the source character set. See [Section 5.4.6 “Constant Types and Formats”](#), to see how these characters can be entered using escape sequences.

### 3.4.1.4 HOW CAN I USE A VARIABLE DEFINED IN ANOTHER SOURCE FILE?

Provided the variable defined in the other source file is not `static` (see [Section 5.5.2.1.1 “Static Variables”](#)) or `auto` (see [Section 5.5.2.2 “Auto Variable Allocation and access”](#)), then adding a declaration for that variable into the current file will allow you to access it. A declaration consists of the keyword `extern` in addition to the type and the name of the variable, as specified in its definition, e.g.,

```
extern int systemStatus;
```

This is part of the C language. Your favorite C textbook will give you more information.

The position of the declaration in the current file determines the scope of the variable. That is, if you place the declaration inside a function, it will limit the scope of the variable to that function. If you place it outside of a function, it allows access to the variable in all functions for the remainder of the current file.

Often, declarations are placed in header files and then they are `#included` into the C source code; see [Section 5.14.2 “Preprocessor Directives”](#).

## 3.4.2 Device-Specific Features

This section discusses the code that needs to be written to set up or control a feature that is specific to Microchip PIC devices.

- [How Do I Set the Configuration Bits?](#)
- [How Do I Use the PIC Device's ID Locations?](#)
- [How Do I Determine the Cause of Reset on Mid-range Parts?](#)
- [How Do I Access SFRs?](#)
- [How Do I Place a Function Into a Unique Section?](#)

See, also, the following linked information in other sections.

- [What Do I Need to Do When Compiling to Use a Debugger?](#)

### 3.4.2.1 HOW DO I SET THE CONFIGURATION BITS?

These should be set in your code using either a macro or a pragma. MPLAB 8 IDE allowed you to set these bits in a dialog, but MPLAB X IDE requires that they be specified in your source code. See [Section 5.3.5 "Configuration Bit Access"](#), for details about how these are set.

### 3.4.2.2 HOW DO I USE THE PIC DEVICE'S ID LOCATIONS?

There is a supplied macro or pragma that allows these values to be programmed; see [Section 5.3.7 "ID Locations"](#).

### 3.4.2.3 HOW DO I DETERMINE THE CAUSE OF RESET ON MID-RANGE PARTS?

The TO and PD bits in the STATUS register allow you to determine the cause of a Reset. However, these bits are quickly overwritten by the runtime startup code that is executed before `main` is executed; see [Section 5.10.1 "Runtime Startup Code"](#). You can have the STATUS register saved into a location that is later accessible from C code, so that the cause of Reset can be determined by the application after it is running again; see [Section 5.10.1.4 "STATUS Register Preservation"](#).

### 3.4.2.4 HOW DO I ACCESS SFRS?

The compiler ships with header files; see [Section 5.3.3 "Device Header Files"](#), that define the variables that are mapped over the top of memory-mapped SFRs. Since these are C variables, they can be used like any other C variables and no new syntax is required to access these registers.

Bits within SFRs can also be accessed. Individual bit-wide variables are defined that are mapped over the bits in the SFR. Bit-fields are also available in structures that map over the SFR as a whole. You can use either in your code; see [Section 5.3.6 "Using SFRs From C Code"](#).

The name assigned to the variable is usually the same as the name specified in the device data sheet. See [Section 3.4.2.5 "How Do I Find The Names Used to Represent SFRs and Bits?"](#), if these names are not recognized.

## 3.4.2.5 HOW DO I FIND THE NAMES USED TO REPRESENT SFRS AND BITS?

Special function registers and the bits within them are accessed via special variables that map over the register; see [Section 3.4.2.4 “How Do I Access SFRs?”](#). However, the names of these variables sometimes differ from those indicated in the data sheet for the device you are using.

If required, you can examine the `<xc.h>` header file to find the device-specific header file that is relevant for your device. This file will define the variables that allow access to these special variables. However, an easier way to find these variable names is to look in any of the preprocessed files left behind from a previous compilation. Provided the corresponding source file included `<xc.h>`, the preprocessed file will show the definitions for all the SFR variables and bits for your target device.

If you are compiling under MPLAB X IDE, the preprocessed file(s) are left under the `build/default/production` directory of your project for regular builds, or under `build/default/debug` for debug builds. They are typically left in the source file directory if you are compiling on the command line. These files have a `.pre` extension.

## 3.4.3 Memory Allocation

Here are questions relating to how your source code affects memory allocation.

- [How Do I Position Variables at an Address I Nominate?](#)
- [How Do I Place a Variable Into a Unique Section?](#)
- [How Do I Position a Variable Into an Address Range?](#)
- [How Do I Position Functions at an Address I Nominate?](#)
- [How Do I Place Variables in Program Memory?](#)
- [How Do I Place a Function Into a Unique Section?](#)
- [How Do I Position a Function Into an Address Range?](#)
- [How Do I Place a Function Into a Unique Section?](#)

See, also, the following linked information in other sections.

- [Why Are Some Objects Positioned Into Memory That I Reserved?](#)
- [How Do I Use High-Endurance Flash for Data, Not Code?](#)

### 3.4.3.1 HOW DO I POSITION VARIABLES AT AN ADDRESS I NOMINATE?

The easiest way to do this is to make the variable absolute by using the `@ address` construct, see [Section 5.5.4 “Absolute Variables”](#). This means that the address you specify is used in preference to the variable’s symbol in generated code. Since you nominate the address, you have full control over where objects are positioned. But, you must also ensure that absolute variables do not overlap. Variables placed in the middle of banks can cause havoc with the allocation of other variables and lead to “Can’t find space” errors; see [Section 3.7.6 “How Do I Fix a “Can’t find space...” Error?”](#). See also, [Section 5.5.2 “Variables in Data Space Memory”](#) and [Section 5.5.3 “Variables in Program Space”](#) for information on moving variables.

### 3.4.3.2 HOW DO I PLACE A VARIABLE INTO A UNIQUE SECTION?

Use the `__section()` specifier to have the variable positioned in a new section (psect). After this has been done, the section can be linked to the desired address by using the `-L-` driver option. See [Section 5.15.4 “Changing and Linking the Allocated Section”](#) for examples of both these operations.

## 3.4.3.3 HOW DO I POSITION A VARIABLE INTO AN ADDRESS RANGE?

You need to move the variable into a unique psect (section), define a memory range, and then place the new section in that range.

Use the `__section()` specifier to have the variable positioned in a new section. Use the `-L-` driver option to define a memory range and to place the new section in that range. See [Section 5.15.4 “Changing and Linking the Allocated Section”](#) for examples of all these operations.

## 3.4.3.4 HOW DO I POSITION FUNCTIONS AT AN ADDRESS I NOMINATE?

The easiest way to do this is to make the functions absolute by using the `@ address` construct, see [Section 5.8.4 “Changing the Default Function Allocation”](#). This means that the address you specify is used in preference to the function's symbol in generated code. Since you nominate the address, you have full control over where functions are positioned, but must also ensure that absolute functions do not overlap. Functions placed in the middle of pages can cause havoc with the allocation of other functions and lead to “Can't find space” errors, see [Section 3.7.6 “How Do I Fix a “Can't find space...” Error?”](#).

## 3.4.3.5 HOW DO I PLACE VARIABLES IN PROGRAM MEMORY?

The `const` qualifier implies that the qualified variable is read-only. As a consequence of this, any variables (except for auto variables or function parameters) that are qualified `const` are placed in program memory, thus freeing valuable data RAM. See [Section 5.5.3 “Variables in Program Space”](#), for more information. Variables that are qualified `const` can also be made absolute, so that they can be positioned at an address you nominate; see [Section 5.5.4.2 “Absolute Objects in Program Memory”](#).

## 3.4.3.6 HOW DO I PLACE A FUNCTION INTO A UNIQUE SECTION?

Use the `__section()` specifier to have the function positioned into a new section (psect). When this has been done, the section can be linked to the desired address by using the `-L-` driver option. See [Section 5.15.4 “Changing and Linking the Allocated Section”](#) for examples of both these operations.

## 3.4.3.7 HOW DO I POSITION A FUNCTION INTO AN ADDRESS RANGE?

Having one or more functions located in a special area of memory might mean that you can ensure they are code protected, for example. To do this, you need to move the function into a unique section (psect), define a memory range, and then place the new section in that range.

Use the `__section()` specifier to have the function positioned into a new section. Use the `-L-` driver option to define a memory range and to place the new section into that range. See [Section 5.15.4 “Changing and Linking the Allocated Section”](#) for examples of all these operations.

## 3.4.3.8 HOW DO I STOP THE COMPILER FROM USING CERTAIN MEMORY LOCATIONS?

Memory can be reserved when you build. The `--RAM` and `--ROM` options allow you to adjust the ranges of data and program memory, respectively, when you build; see [Section 4.8.52 “--RAM: Adjust RAM Ranges”](#), and [Section 4.8.53 “--ROM: Adjust ROM Ranges”](#). By default, all the available on-chip memory is available for use. However, these options allow you to reserve parts of this memory.

## 3.4.4 Variables

This sections examines questions that relate to the definition and usage of variables and types within a program.

- [Why Are My Floating-point Results Not Quite What I Am Expecting?](#)
- [How Can I Access Individual Bits of a Variable?](#)
- [How Long Can I Make My Variable and Macro Names?](#)

See, also, the following linked information in other sections.

- [How Do I Share Data Between Interrupt and Main-line Code?](#)
- [How Do I Position Variables at an Address I Nominate?](#)
- [How Do I Place Variables in Program Memory?](#)
- [How Do I Place Variables in the PIC18 Device's External Program Memory?](#)
- [How Can I Rotate a Variable?](#)
- [How Do I Utilize/Allocate the RAM Banks on My Device?](#)
- [How Do I Utilize the Linear Memory on Enhanced Mid-range PIC Devices?](#)
- [How Do I Find Out Where Variables and Functions Have Been Positioned?](#)

### 3.4.4.1 WHY ARE MY FLOATING-POINT RESULTS NOT QUITE WHAT I AM EXPECTING?

First, if you are watching floating-point variables in MPLAB X IDE, make sure that their type and size agree with the way in which they are defined. For 24-bit floating point variables (whether they have type `float` or `double`), ensure that in MPLAB X IDE the Display Column Value As popup menu to IEEE Float (24 bit). If the variable is a 32-bit floating point object, set the types to IEEE Float.

The size of the floating point type can be adjusted for both `float` and `double` types; see [Section 4.8.32 "--FLOAT: Select Kind of Float Types"](#), and [Section 4.8.24 "--DOUBLE: Select Kind of Double Types"](#).

Since floating-point variables only have a finite number of bits to represent the values they are assigned, they will hold an approximation of their assigned value; see [Section 5.4.3 "Floating-Point Data Types"](#). A floating-point variable can only hold one of a set of discrete real number values. If you attempt to assign a value that is not in this set, it is rounded to the nearest value. The more bits used by the mantissa in the floating-point variable, the more values can be exactly represented in the set, and the average error due to the rounding is reduced.

Whenever floating-point arithmetic is performed, rounding also occurs. This can also lead to results that do not appear to be correct.

## 3.4.4.2 HOW CAN I ACCESS INDIVIDUAL BITS OF A VARIABLE?

There are several ways of doing this. The simplest and most portable way is to define an integer variable and use macros to read, set, or clear the bits within the variable using a mask value and logical operations, such as the following.

```
#define testbit(var, bit) ((var) & (1 << (bit)))
#define setbit(var, bit) ((var) |= (1 << (bit)))
#define clrbit(var, bit) ((var) &= ~(1 << (bit)))
```

These, respectively, test to see if bit number, `bit`, in the integer, `var`, is set; set the corresponding `bit` in `var`; and clear the corresponding `bit` in `var`. Alternatively, a union of an integer variable and a structure with bit-fields (see [Section 5.4.4.2 “Bit-Fields in Structures”](#)) can be defined, e.g.,

```
union both {
    unsigned char byte;
    struct {
        unsigned b0:1, b1:1, b2:1, b3:1, b4:1, b5:1, b6:1, b7:1;
    } bitv;
} var;
```

This allows you to access `byte` as a whole (using `var.byte`), or any bit within that variable independently (using `var.bitv.b0` through `var.bitv.b7`).

Note that the compiler does support bit variables (see [Section 5.4.2.1 “Bit Data Types and Variables”](#)), as well as bit-fields in structures.

## 3.4.4.3 HOW LONG CAN I MAKE MY VARIABLE AND MACRO NAMES?

The C Standard indicates that only a specific number of initial characters in an identifier are significant, but it does not actually state what this number is and it varies from compiler to compiler. For XC8, the first 255 characters are significant, but this can be reduced using the `-N` option; see [Section 4.8.8 “-N: Identifier Length”](#). The fewer characters there are in your variable names, the more portable your code. Using the `-N` option allows the compiler to check that your identifiers conform to a specific length. This option affects variable and function names, as well as preprocessor macro names.

If two identifiers only differ in the non-significant part of the name, they are considered to represent the same object, which will almost certainly lead to code failure.

## 3.4.5 Functions

This section examines questions that relate to functions.

- [What is the Optimum Size For Functions?](#)
- [How Do I Stop An Unused Function Being Removed?](#)
- [How Do I Make a Function Inline?](#)

See, also, the following linked information in other sections.

- [How Can I Tell How Big a Function Is?](#)
- [How Do I Position Functions at an Address I Nominate?](#)
- [How Do I Know Which Resources Are Being Used by Each Function?](#)
- [How Do I Find Out Where Variables and Functions Have Been Positioned?](#)
- [How Do I Use Interrupts in C?](#)

## 3.4.5.1 WHAT IS THE OPTIMUM SIZE FOR FUNCTIONS?

Generally speaking, the source code for functions should be kept small, as this aids in readability and debugging. It is much easier to describe and debug the operation of a function that performs a small number of tasks. And, they typically have fewer side effects, which can be the source of coding errors.

In the embedded programming world, a large number of small functions, and the calls necessary to execute them, can result in excessive memory and stack usage, so a compromise is often necessary.

The PIC10/12/16 devices employ pages in the program memory that are used to store and execute function code. Although you are able to write C functions that will generate more than one page of assembly code, functions of such a size should be avoided and split into smaller routines where possible. The assembly call and jump sequences to locations in other pages are much longer than those made to destinations in the same page. If a function is so large as to cross a page boundary, then loops (or other code constructs that require jumps within that function) can use the longer form of jump on each iteration; see [Section 5.8.3 “Allocation of Executable Code”](#).

PIC18 devices are less affected by internal memory paging and the instruction set allows for calls and jumps to any destination with no penalty. But you should still endeavor to keep functions as small as possible.

Interrupt functions must be written so that they do not exceed the size of a memory page. They cannot be split to occupy more than one page.

With all devices, the smaller the function, the easier it is for the linker to allocate it to memory without errors.

## 3.4.5.2 HOW DO I STOP AN UNUSED FUNCTION BEING REMOVED?

If a C function's symbol is referenced in hand-written assembly code, the function will never be removed, even if it is not called or never had its address taken in C code.

Create an assembly source file and add this file to your project. You only have to reference the symbol in this file; so, the file can contain the following

```
GLOBAL _myFunc
```

where `myFunc` is the C name of the function in question (note the leading underscore in the assembly name, see [Section 5.12.3.1 “Equivalent Assembly Symbols”](#)). This is sufficient to prevent the function removal optimization from being performed.

## 3.4.5.3 HOW DO I MAKE A FUNCTION INLINE?

You can ask the compiler to inline a function by using the `inline` specifier (see [Section 5.8.1.2 “Inline Specifier”](#)) or `#pragma inline`. This is only a suggestion to the compiler and cannot always be obeyed. Do not confuse this specifier/pragma with the `intrinsic` pragma<sup>1</sup> (see [Section 5.14.4.4 “The #pragma Intrinsic Directive”](#)), which is for functions that have no corresponding source code and which will be specifically expanded by the code generator during compilation.

---

1. This specifier was originally named in-line but was changed to avoid confusion.



## 3.4.6 Interrupts

Interrupt and interrupt service routine questions are discussed in this section.

*[How Do I Use Interrupts in C?](#)*

See, also, the following linked information in other sections.

- *[How Can I Make My Interrupt Routine Faster?](#)*
- *[How Do I Share Data Between Interrupt and Main-line Code?](#)*

### 3.4.6.1 HOW DO I USE INTERRUPTS IN C?

First, be aware of what sort of interrupt hardware is available on your target device. Most baseline PIC devices do not implement interrupts at all; baseline devices with interrupts and mid-range devices utilize a single interrupt vector, and PIC18 devices implement two separate interrupt vector locations and use a simple priority scheme. Some PIC18 devices use an interrupt controller macro module that can use a vector table to invoke multiple interrupt functions.

In C source code, a function can be written to act as the interrupt service routine; see [Section 5.9.1 “Writing an Interrupt Service Routine”](#). Such functions save and/or restore program context before and/or after executing the function body code and a different return instruction is used, see [Section 5.9.4 “Context Switching”](#).

Code inside the interrupt function can do anything you like, but see [Section 3.6.7 “How Can I Make My Interrupt Routine Faster?”](#) for suggestions to enhance real-time performance.

Prior to any interrupt occurring, your program must ensure that peripherals are correctly configured and that interrupts are enabled; see [Section 5.9.5 “Enabling Interrupts”](#). On PIC18 devices, you must specify the priority of interrupt sources by writing the appropriate SFRs.



## 3.4.7 Assembly Code

This section examines questions that arise when writing assembly code as part of a C project.

- [How Should I Combine Assembly and C Code?](#)
- [What Do I Need Other than Instructions in an Assembly Source File?](#)
- [How Do I Access C Objects from Assembly Code?](#)
- [How Can I Access SFRs from Within Assembly Code?](#)
- [What Things Must I Manage When Writing Assembly Code?](#)

### 3.4.7.1 HOW SHOULD I COMBINE ASSEMBLY AND C CODE?

Ideally, any hand-written assembly should be written as separate routines that can be called. This offers some degree of protection from interaction between compiler-generated and hand-written assembly code. Such code can be placed into a separate assembly module that can be added to your project; see [Section 5.12.1 "Integrating Assembly Language Modules"](#).

If necessary, assembly code can be added in-line with C code using either of two methods; see [Section 5.12.2 "#asm, #endasm and asm\(\)"](#). The code added in-line should ideally be limited to instructions such as `NOP`, `SLEEP` or `CLRWDI`. Macros are already provided which in-line all these instructions; see [Appendix A. Library Functions](#). More complex in-line assembly that changes register contents and the device state can cause code failure if precautions are not taken and should be used with caution. See [Section 5.7 "Register Usage"](#) for those registers used by the compiler.

### 3.4.7.2 WHAT DO I NEED OTHER THAN INSTRUCTIONS IN AN ASSEMBLY SOURCE FILE?

Assembly code typically needs assembler directives as well as the instructions themselves. The operation of all the directives are described in the subsections of [Section 6.2.9 "Assembler Directives"](#). Common directives required are mentioned below.

All assembly code must be placed in a psect so it can be manipulated as a whole by the linker and placed in memory. See [Section 5.15.1 "Program Sections"](#) for general information on psects; see [Section 6.2.9.3 "PSECT"](#) for information on the directive used to create and specify psects.

The other commonly used directive is `GLOBAL`, defined in [Section 6.2.9.1 "GLOBAL"](#) which is used to make symbols accessible across multiple source files.

### 3.4.7.3 HOW DO I ACCESS C OBJECTS FROM ASSEMBLY CODE?

Most C objects are accessible from assembly code. There is a mapping between the symbols used in the C source and those used in the assembly code generated from this source. Your assembly should access the assembly-equivalent symbols which are detailed in [Section 5.12.3 "Interaction between Assembly and C Code"](#).

Instruct the assembler that the symbol is defined elsewhere by using the `GLOBAL` assembler directive; see [Section 6.2.9.1 "GLOBAL"](#). This is the assembly equivalent of a C declaration, although no type information is present. This directive is not needed and should not be used if the symbol is defined in the same module as your assembly code.

Any C variable accessed from assembly code will be treated as if it were qualified `volatile`; see [Section 5.4.7.2 "Volatile Type Qualifier"](#). Specifically specifying the `volatile` qualifier in C code is preferred as it makes it clear that external code can access the object.

## 3.4.7.4 HOW CAN I ACCESS SFRS FROM WITHIN ASSEMBLY CODE?

The safest way to gain access to SFRs in assembly code is to have symbols defined in your assembly code that equate to the corresponding SFR address. Header files are provided with the compiler so that you do not need to define these yourselves, and they are detailed in [Section 5.12.3.2 “Accessing Registers from Assembly Code”](#).

There is no guarantee that you will be able to access symbols generated by the compilation of C code, even the code that accesses the SFR that you require.

## 3.4.7.5 WHAT THINGS MUST I MANAGE WHEN WRITING ASSEMBLY CODE?

When writing assembly code by hand, you assume responsibility for managing certain features of the device and formatting your assembly instructions and operands. The following list describes some of the actions you must take.

- Whenever you access a RAM variable, you must ensure that the bank of the variable is selected before you read or write the location. This is done by one or more assembly instructions. The exact code is based on the device you are using and the location of the variable. Bank selection is not required if the object is in common memory, (which is called the access bank on PIC18 devices) or if you are using an instruction that takes a full address (such as the `MOVFF` instruction on PIC18 devices). Check your device data sheet to see the memory architecture of your device, and the instructions and registers which control bank selection. Failure to select the correct bank will lead to code failure.

The `BANKSEL` pseudo instruction can be used to simplify this process; see [Section 6.2.1.2 “Bank and Page Selection”](#).

- You must ensure that the address of the RAM variable you are accessing has been masked so that only the bank offset is being used as the instruction's file register operand. This should not be done if you are using an instruction that takes a full address (such as the `MOVFF` instruction on PIC18 devices). Check your device data sheet to see what address operand instructions requires. Failure to mask an address can lead to a fixup error (see [Section 3.7.8 “How Do I Fix a Fixup Overflow Error?”](#)) or code failure.

The `BANKMASK` macro can truncate the address for you; see [Section 5.12.3.2 “Accessing Registers from Assembly Code”](#).

- Before you call or jump to any routine, you must ensure that you have selected the program memory page of this routine using the appropriate instructions. You can either use the `PAGESEL` pseudo instruction; see [Section 6.2.1.2 “Bank and Page Selection”](#), or the `FCALL` or `LJMP` pseudo instructions (not required on PIC18 devices); see [Section 6.2.1.8 “Long Jumps and Calls”](#) which will automatically add page selection instructions, if required.
- You must ensure that any RAM used for storage has memory reserved. If you are only accessing variables defined in C code, then reservation is already done by the compiler. You must reserve memory for any variables you only use in the assembly code using an appropriate directive such as `DS` or `DABS`; see [Section 6.2.9.11 “DS”](#) or [Section 6.2.9.12 “DABS”](#). It is often easier to define objects in C code rather than in assembly code.

- You must place any assembly code you write in a psect (see [Section 6.2.9.3 “PSECT”](#) for the directive to do this, and [Section 5.15.1 “Program Sections”](#) for general information about psects). A psect you define may need flags (options) to be specified. Take particular notice of the `delta`, `space`, `reloc` and `class` flags (see [Section 6.2.9.3.4 “Delta”](#), and [Section 6.2.9.3.17 “Space”](#), [Section 6.2.9.3.15 “Reloc”](#) and [Section 6.2.9.3.3 “Class”](#)). If these are not set correctly, compile errors or code failure will almost certainly result. If the psect specifies a class and you are happy with it being placed anywhere in the memory range defined by that class (see [Section 7.2.1 “-Aclass =low-high,...”](#)), it does not need any additional options to be linked; otherwise, you will need to link the psect using a linker option (see [Section 7.2.18 “-Pspec”](#) for the usual way to link psects and [Section 4.8.6 “-L-: Adjust Linker Options Directly”](#) which indicates how you can specify this option without running the linker directly). Assembly code that is placed in-line with C code will be placed in the same psect as the compiler-generated assembly and you should not place this into a separate psect.
- You must ensure that any registers you write to in assembly code are not already in used by compiler-generated code. If you write assembly in a separate module, then this is less of an issue because the compiler will, by default, assume that all registers are used by these routines (see [Section 5.7 “Register Usage”](#)). No assumptions are made for in-line assembly (although the compiler will assume that the selected bank was changed by the assembly, see [Section 5.12.2 “#asm, #endasm and asm\(\)”](#)) and you must be careful to save and restore any resources that you use (modify) and which are already in use by the surrounding compiler-generated code.

## 3.5 GETTING MY APPLICATION TO DO WHAT I WANT

This section provides programming techniques, applications and examples. It also examines questions that relate to making an application perform a specific task.

- [What Can Cause Glitches on Output Ports?](#)
- [Where Am I Allowed To Manually Link Psects?](#)
- [How Do I Link Bootloaders and Downloadable Applications?](#)
- [What Do I Need to Do When Compiling to Use a Debugger?](#)
- [How Can I Have Code Executed Straight After Reset?](#)
- [How Do I Share Data Between Interrupt and Main-line Code?](#)
- [How Can I Prevent Misuse of My Code?](#)
- [How Do I Use Printf to Send Text to a Peripheral?](#)
- [How Do I Setup the Oscillator in My Code?](#)
- [How Do I Place Variables in the PIC18 Device's External Program Memory?](#)
- [How Can I Implement a Delay in My Code?](#)
- [How Can I Rotate a Variable?](#)
- [How Can I Stop Variables Being Cleared at Startup?](#)
- [How Do I Use High-Endurance Flash for Data, Not Code?](#)

### 3.5.1 What Can Cause Glitches on Output Ports?

In most cases, this is caused by using ordinary variables to access port bits or the entire port itself. These variables should be qualified `volatile`.

The value stored in a variable mapped over a port (hence the actual value written to the port) directly translates to an electrical signal. It is vital that the values held by these variables only change when the code intends them to, and that they change from their current state to their new value in a single transition. See [Section 5.4.7.2 "Volatile Type Qualifier"](#). The compiler attempts to write to volatile variables in one operation.

### 3.5.2 Where Am I Allowed To Manually Link Psects?

It is recommended that the linker options for compiler-generated psects (sections) are not modified. If these must be changed or if there are user-defined psects that need special allocation, there might be device- or compiler-imposed restrictions on where these can be placed in memory.

Try to link psects in a suitable compiler linker class, as shown in [Section 5.15.3 "Default Linker Classes"](#), as the definitions for these memory ranges take into consideration any restrictions. Define your own linker class, if necessary. See for example [Section 3.4.3.3 "How Do I Position a Variable Into an Address Range?"](#). Check [Section 5.15.2 "Compiler-Generated Psects"](#) to see the memory placement restrictions that apply to compiler-generated psects which hold similar content to your psect.

Most limitations relate to psects straddling some memory boundary, such as a data bank or program memory page. One typical limitation is that all psects holding executable code cannot straddle a device page boundary. Compiler-generated psects holding variables must also be typically linked within the data bank for which they were created. These boundaries, therefore, impose limits on the size to which the psect can grow.

### 3.5.3 How Do I Link Bootloaders and Downloadable Applications?

Exactly how this is done depends on the device you are using and your project requirements, but the general approach when compiling applications that use a bootloader is to allocate discrete program memory space to the bootloader and application so they have their own dedicated memory. In this way the operation of one cannot affect the other. This will require that either the bootloader or the application is offset in memory. That is, the Reset and interrupt location are offset from address 0 and all program code is offset by the same amount.

On PIC18 devices, typically the application code is offset, and the bootloader is linked with no offset so that it populates the Reset and interrupt code locations. The bootloader Reset and interrupt code merely contains code which redirects control to the real Reset and interrupt code defined by the application and which is offset.

On mid-range devices, this is not normally possible to perform when interrupts are being used. Consider offsetting all of the bootloader with the exception of the code associated with Reset, which must always be defined by the bootloader. The application code can define the code linked at the interrupt location. The bootloader will need to remap any application code that attempts to overwrite the Reset code defined by the bootloader.

The option `--CODEOFFSET`, (see [Section 4.8.21 "--CODEOFFSET: Offset Program Code to Address"](#)), allows the program code (Reset and vectors included) to be moved by a specified amount. The option also restricts the program from using any program memory from address 0 (Reset vector) to the offset address. Always check the map file; see [Section 7.4.2 "Contents"](#), to ensure that nothing remains in reserved areas.

The contents of the HEX file for the bootloader can be merged with the code of the application by adding the HEX file as a project file, either on the command line, or in MPLAB X IDE. This results in a single HEX file that contains the bootloader and application code in the one image. HEX files are merged by the HEXMATE application; see [Section 8.3 "HEXMATE"](#). Check for warnings from this application about overlap, which can indicate that memory is in use by both bootloader and the downloadable application.

### 3.5.4 What Do I Need to Do When Compiling to Use a Debugger?

You can use debuggers, such as ICD3 or REALICE, to debug code built with the MPLAB XC8 compiler. These debuggers use some of the data and program memory of the device for its own use, so it is important that your code does not also use these resources.

There is a command-line option; see [Section 4.8.22 "--DEBUGGER: Select Debugger Type"](#), that can be used to tell the compiler which debugger is to be used. The compiler can then reserve the memory used by the debugger so that your code will not be located in these locations.

In the MPLAB X IDE, the appropriate debugger option is specified if you perform a debug build. It will not be specified if you perform a regular Build Project or Clean and Build.

Since some device memory is being used up by the debugger, there is less available for your program and it is possible that your code or data might not fit in the device when a debugger is selected.

Note that which specific memory locations used by the debuggers is an attribute of MPLAB X IDE, not the device. If you move a project to a new version of the IDE, the resources required can change. For this reason, you should not manually reserve memory for the debugger, or make any assumptions in your code as to what memory is used. A summary of the debugger requirements is available in the MPLAB X IDE help files.

To verify that the resources reserved by the compiler match those required by the debugger, do the following. Compile your code with and without the debugger selected and keep a copy of the map file produced for both builds. Compare the linker options in the map files and look for changes in the `-A` options; see [Section 7.2.1 “-Aclass =low-high,...”](#). For example, the memory defined for the `CODE` class with no debugger might be specified by this option:

```
-ACODE=00h-0FFh,0100h-07FFh,0800h-0FFFhx3
```

and with the ICD3 selected as the debugger, it becomes:

```
-ACODE=00h-0FFh,0100h-07FFh,0800h-0FFFhx2,01800h-01EFFh
```

This shows that a memory range from 1F00 to 1FFF has been removed by the compiler and cannot be used by your program. See also [Section 3.6.16 “Why Are Some Objects Positioned Into Memory That I Reserved?”](#).

### 3.5.5 How Can I Have Code Executed Straight After Reset?

A special hook has been provided so you can easily add special “powerup” assembly code that will be linked to the Reset vector; see [Section 5.10.2 “The Powerup Routine”](#). This code will be executed before the runtime startup code, which in turn is executed before the `main` function; see [Section 5.10 “Main, Runtime Startup and Reset”](#).

### 3.5.6 How Do I Share Data Between Interrupt and Main-line Code?

Variables accessed from both interrupt and main-line code can easily become corrupted or mis-read by the program. The `volatile` qualifier (see [Section 5.4.7.2 “Volatile Type Qualifier”](#)) tells the compiler to avoid performing optimizations on such variables. This will fix some of the issues associated with this problem.

The other issues relates to whether the compiler/device can access the data atomically. With 8-bit PIC devices, this is rarely the case. An atomic access is one where the entire variable is accessed in only one instruction. Such access is uninterruptible. You can determine if a variable is being accessed atomically by looking at the assembly code the compiler produces in the assembly list file; see [Section 6.4 “Assembly List Files”](#). If the variable is accessed in one instruction, it is atomic. Since the way variables are accessed can vary from statement to statement it is usually best to avoid these issues entirely by disabling interrupts prior to the variable being accessed in main-line code, then re-enable the interrupts afterwards; see [Section 5.9.5 “Enabling Interrupts”](#).

### 3.5.7 How Can I Prevent Misuse of My Code?

First, many devices with flash program memory allow all or part of this memory to be write protected. The device Configuration bits need to be set correctly for this to take place; see [Section 5.3.5 “Configuration Bit Access”](#) and your device data sheet.

Second, you can prevent third-party code being programmed at unused locations in the program memory by filling these locations with a value rather than leaving them in an unprogrammed state. You can chose a fill value that corresponds to an instruction or set all the bits so as the values cannot be further modified. (Consider what will happen if your program somehow reaches and starts executing from these filled values.)

The compiler's HEXMATE utility (see [Section 8.3 “HEXMATE”](#)) has the capability to fill unused locations and this operation can be requested using a command-line driver option; see [Section 4.8.31 “--FILL: Fill Unused Program Memory”](#). As HEXMATE only works with HEX files, this feature is only available when producing HEX/COF file outputs (as opposed to binary, for example), which is the default operation.

And last, if you wish to make your library files or intermediate p-code files available to others but do not want the original source code to be viewable, then you can obfuscate the files using the `--SHROUD` option; see [Section 4.8.58 “--SHROUD: Obfuscate P-code Files”](#)



### 3.5.8 How Do I Use Printf to Send Text to a Peripheral?

The `printf` function does two things: it formats text based on the format string and placeholders you specify, and sends (prints) this formatted text to a destination (or stream); see [Appendix A. Library Functions](#). The `printf` function performs all the formatting; then it calls a helper function, called `putch`, to send each byte of the formatted text. By customizing the `putch` function you can have `printf` send data to any peripheral or location; see [Section 5.12 “Mixing C and Assembly Code”](#). You can choose the `printf` output go to an LCD, SPI module or USART, for example.

A stub for the `putch` function can be found in the compiler's `sources` directory. Copy it into your project then modify it to send the single byte parameter passed to it to the required destination. Before you can use `printf`, peripherals that you use will need to be initialized in the usual way. Here is an example of `putch` for a USART on a mid-range device.

```
void putch(char data) {
    while( ! TXIF) // check buffer
        continue; // wait till ready
    TXREG = data; // send data
}
```

You can get `printf` to send to one of several destinations by using a global variable to indicate your choice. Have the `putch` function send the byte to one of several destinations based on the contents of this variable.

### 3.5.9 How Do I Setup the Oscillator in My Code?

All PIC devices have several oscillator modes that must be selected by programming the device's configuration bits in your project. See your device data sheet for information on the modes and [Section 5.3.5 “Configuration Bit Access”](#) for assistance with programming the configuration bits.

Some devices have an `OSCCON` register, which further controls such runtime attributes as clock sources and internal clock frequencies. In C source, this register can be written to in the usual way, based on information in your device data sheet.

Some devices allow the internal oscillator to be tuned at runtime via the `OSCTUNE` register. Other devices allow for calibration of their internal oscillators using values pre-programmed into the device. The runtime startup code generated by the compiler, (see [Section 5.10.1 “Runtime Startup Code”](#)), will by default provide code that performs oscillator calibration. This can be disabled, if required, using an option; see [Section 4.8.54 “--RUNTIME: Specify Runtime Environment”](#).

If you intend to use some of the compiler's built-in delay functions, you will need to set the `_XTAL_FREQ` macro, which indicates the system frequency to the compiler. This macro in no way affects the operating frequency of the device. See [Section “\\_\\_DELAY\\_MS, \\_\\_DELAY\\_US, \\_\\_delaywdt\\_us, \\_\\_delaywdt\\_Ms”](#).

### 3.5.10 How Do I Place Variables in the PIC18 Device's External Program Memory?

If all you mean to do is place read-only variables in program memory, qualify them as `const`; see [Section 5.5.3 “Variables in Program Space”](#). If you intend the variables to be located in the external program memory then use the `far` qualifier and specify the memory using the `--RAM` option; see [Section 4.8.52 “--RAM: Adjust RAM Ranges”](#). The compiler will allow `far`-qualified variables to be modified. Note that the time to access these variables will be longer than for variables in the internal data memory. The access mode to external memory can be specified with an option; see [Section 4.8.26 “--EMI: Select External Memory Interface Operating Mode”](#).

## 3.5.11 How Can I Implement a Delay in My Code?

If an accurate delay is required, or if there are other tasks that can be performed during the delay, then using a timer to generate an interrupt is the best way to proceed.

If these are not issues in your code, then you can use the compiler's in-built delay pseudo-functions: `_delay`, `__delay_ms` or `__delay_us`; see [Appendix A. Library Functions](#). These all expand into in-line assembly instructions or a (nested) loop of instructions that will consume the specified number of cycles or time. The delay argument must be a constant and less than 50,463,240.

Note that these code sequences will only use the `NOP` instruction and/or instructions which form a loop. The alternate versions of these pseudo-functions, e.g., `_delaywdt`, can use the `CLRWDT` instruction as well.

## 3.5.12 How Can I Rotate a Variable?

The C language does not have a rotate operator, but rotations can be performed using the shift and bitwise OR operators. Since the PIC devices have a rotate instruction, the compiler will look for code expressions that implement rotates (using shifts and ORs) and use the rotate instruction in the generated output wherever possible; see [Section 5.6.2 "Rotation"](#).

## 3.5.13 How Can I Stop Variables Being Cleared at Startup?

Use the `persistent` qualifier (see [Section 5.4.8.1 "Persistent Type Qualifier"](#)), which will place the variables in a different psect that is not cleared by the runtime startup code.

## 3.5.14 How Do I Use High-Endurance Flash for Data, Not Code?

For devices that implement this Flash in the program memory space, it will need to be reserved so that the compiler does not use it for executable code. See [Section 3.4.3.8 "How Do I Stop the Compiler From Using Certain Memory Locations?"](#)



## 3.6 UNDERSTANDING THE COMPILATION PROCESS

This section tells you how to find out what the compiler did during the build process, how it encoded output code, where it placed objects, etc. It also discusses the features that are supported by the compiler.

- [What's the Difference Between the Free, Standard and PRO Modes?](#)
- [How Can I Make My Code Smaller?](#)
- [How Can I Reduce RAM Usage?](#)
- [How Can I Make My Code Faster?](#)
- [How Can I Speed Up Programming Times](#)
- [How Does the Compiler Place Everything in Memory?](#)
- [How Can I Make My Interrupt Routine Faster?](#)
- [How Big Can C Variables Be?](#)
- [How Do I Utilize/Allocate the RAM Banks on My Device?](#)
- [How Do I Utilize the Linear Memory on Enhanced Mid-range PIC Devices?](#)
- [What Devices are Supported by the Compiler?](#)
- [How Do I Know What Code the Compiler Is Producing?](#)
- [How Can I Tell How Big a Function Is?](#)
- [How Do I Know Which Resources Are Being Used by Each Function?](#)
- [How Do I Find Out Where Variables and Functions Have Been Positioned?](#)
- [Why Are Some Objects Positioned Into Memory That I Reserved?](#)
- [How Do I Know How Much Memory Is Still Available?](#)
- [How Do I Use Library Files in My Project?](#)
- [What Optimizations Are Employed by the Compiler?](#)
- [Why Do I Get Out-of-memory Errors When I Select a Debugger?](#)
- [How Do I Know Which Stack Model the Compiler Has Assigned to a Function?](#)
- [How Do I Know What Value Has Been Programmed in the Configuration Bits or ID Location?](#)

See, also, the following linked information in other sections.

- [How Do I Find Out What an Warning/Error Message Means?](#)
- [What is Different About an MPLAB X IDE Debug Build?](#)
- [How Do I Stop An Unused Function Being Removed?](#)
- [How Do I Build Libraries?](#)

### 3.6.1 What's the Difference Between the Free, Standard and PRO Modes?

These modes (see [Section 1.2 "Compiler Description and Documentation"](#)) mainly differ in the optimizations that are performed when compiling. Compilers operating in Free (formerly called Lite) and Standard mode can compile for all the same devices as supported by the Pro mode. The code compiled in Free and Standard mode can use all the available memory for the selected device. What will be different is the size and speed of the generated compiler output. Free mode output will be much less efficient when compared to that produced in Standard mode, which in turn will be less efficient than that produce when in Pro mode.

All these modes use the OCG compiler framework, so the entire C program is compiled in one step and the source code does not need many non-standard extensions.

There are a small number of command-line options disabled in Free mode, but these do not relate to code features; merely how the compiler can be executed. Most customers never need to use these options. The options are `--GETOPTION` (see [Section 4.8.33 “--GETOPTION: Get Command-line Options”](#)) and `--SETOPTION` (see [Section 4.8.57 “--SETOPTION: Set the Command-line Options for Application”](#)).

## 3.6.2 How Can I Make My Code Smaller?

There are a number of ways that this can be done, but results vary from one project to the next. Use the assembly list file, (see [Section 6.4 “Assembly List Files”](#)), to observe the assembly code produced by the compiler to verify that the following tips are relevant to your code.

Use the smallest data types possible as less code is needed to access these. (This also reduces RAM usage.) Note that a `bit` type and non-standard 24-bit integer type (`short long`) exists for this compiler. Avoid multi-bit bit-fields whenever possible. The code used to access these can be very large. See [Section 5.4 “Supported Data Types and Variables”](#), for all data types and sizes.

There are two sizes of floating-point type, as well, and these are discussed in the same section. Avoid floating-point if at all possible. Consider writing fixed-point arithmetic code.

Use unsigned types, if possible, instead of signed types; particularly if they are used in expressions with a mix of types and sizes. Try to avoid an operator acting on operands with mixed sizes whenever possible.

Whenever you have a loop or condition code, use a “strong” stop condition, i.e., the following:

```
for(i=0; i!=10; i++)
```

is preferable to:

```
for(i=0; i<10; i++)
```

A check for equality (`==` or `!=`) is usually more efficient to implement than the weaker `<` comparison.

In some situations, using a loop counter that decrements to zero is more efficient than one that starts at zero and counts up by the same number of iterations. This is more likely to be the case if the loop index is a byte-wide type. So you might be able to rewrite the above as:

```
for(i=10; i!=0; i--)
```

There might be a small advantage in changing the order of function parameters so that the first parameter is byte sized. A register is used if the first parameter is byte-sized. For example consider:

```
char calc(char mode, int value);
```

over

```
char calc(int value, char mode);
```

Ensure that all optimizations are enabled; see [Section 4.8.45 “--OPT: Invoke Compiler Optimizations”](#). Be aware of what optimizations the compiler performs (see [Section 5.13 “Optimizations”](#), and [Section 6.3 “Assembly-Level Optimizations”](#)) so you can take advantage of them and don't waste your time manually performing optimizations in C code that the compiler already handles, e.g., don't turn a multiply-by-4 operation into a shift-by-2 operation as this sort of optimization is already detected.

### 3.6.3 How Can I Reduce RAM Usage?

Use the smallest data types possible. (This also reduces code size as less code is needed to access these.) Note that a `bit` type and non-standard 24-bit integer type (`short long`) exists for this compiler. See [Section 5.4 “Supported Data Types and Variables”](#) for all data types and sizes. There are two sizes of floating-point type, as well, and these are discussed in the same section.

Consider using `auto` variables over global or `static` variables as there is the potential that these can share memory allocated to other `auto` variables that are not active at the same time. Memory allocation of `auto` variables is made on a compiled stack, described in [Section 5.5.2.2 “Auto Variable Allocation and access”](#).

Rather than pass large objects to, or from, functions, pass pointers which reference these objects. This is particularly true when larger structures are being passed, but there might be RAM savings to be made even when passing `long` variables.

Objects that do not need to change throughout the program can be located in program memory using the `const` qualifier; see [Section 5.4.7.1 “Const Type Qualifier”](#), and [Section 5.5.3 “Variables in Program Space”](#). This frees up precious RAM, but slows execution.

Ensure that all optimizations are enabled; see [Section 4.8.45 “--OPT: Invoke Compiler Optimizations”](#). Be aware of which optimizations the compiler performs (see [Section 5.13 “Optimizations”](#)), so that you can take advantage of them and don't waste your time manually performing optimizations in C code that the compiler already handles.

### 3.6.4 How Can I Make My Code Faster?

To a large degree, smaller code is faster code, so efforts to reduce code size often decrease execution time; see [Section 3.6.2 “How Can I Make My Code Smaller?”](#). See also, [Section 3.6.7 “How Can I Make My Interrupt Routine Faster?”](#). However, there are ways some sequences can be sped up at the expense of increased code size.

One of the compiler optimization settings is for speed (the alternate setting is for space), so ensure this is selected; see [Section 4.8.45 “--OPT: Invoke Compiler Optimizations”](#). This will use alternate output in some instances that is faster, but larger.

Some library multiplication routines operate faster when one of their operands is a smaller value. See [Section 5.3.9 “Multiplication”](#) for more information on how to take advantage of this.

Generally, the biggest gains to be made in terms of speed of execution come from the algorithm used in a project. Identify which sections of your program need to be fast. Look for loops that might be linearly searching arrays and choose an alternate search method such as a hash table and function. Where results are being recalculated, consider if they can be cached.

### 3.6.5 How Can I Speed Up Programming Times

The linker can allocate sections to both ends of program memory: some sections initially placed at a low address and built up through memory; other sections assembled at a high address and extended down. This does not affect code operation and makes linking easier, but it can produce a HEX file covering the entire device memory space. Programming this HEX file into the device may take a long time.

To reduce programming times in this situation, instruct the linker to not use all the device's program memory. Use the `--ROM` option to reserve the upper part of program memory, see [Section 4.8.53 “--ROM: Adjust ROM Ranges”](#).

## 3.6.6 How Does the Compiler Place Everything in Memory?

In most situations, assembly instructions and directives associated with both code and data are grouped into sections, called psects, and these are then positioned into containers that represent the device memory. An introductory explanation into this process is given in [Section 5.15.1 “Program Sections”](#). The exception is for absolute variables (see [Section 5.5.4 “Absolute Variables”](#)), which are placed at a specific address when they are defined and which are not placed in a psect.

## 3.6.7 How Can I Make My Interrupt Routine Faster?

Consider suggestions made in [Section 3.6.2 “How Can I Make My Code Smaller?”](#) (code size) for any interrupt code. Smaller code is often faster code.

In addition to the code you write in the ISR there is the code the compiler produces to switch context. This is executed immediately after an interrupt occurs and immediately before the interrupt returns, so must be included in the time taken to process an interrupt; see [Section 5.9.4 “Context Switching”](#). This code is optimal in that only registers used in the ISR will be saved by this code. Thus, the less registers used in your ISR will mean potentially less context switch code to be executed.

Mid-range devices have only a few registers that are used by the compiler, and there is little context switch code. Even fewer registers are considered for saving when compiling for enhanced mid-range device. PIC18 devices will benefit most from the above suggestion as they use a larger set of registers in generated code; see [Section 5.7 “Register Usage”](#).

Generally simpler code will require less resources than more complicated expressions. Use the assembly list file to see which registers are being used by the compiler in the interrupt code; see [Section 6.4 “Assembly List Files”](#).

Consider having the ISR simply set a flag and return. The flag can then be checked in main-line code to handle the interrupt. This has the advantage of moving the complicated interrupt-processing code out of the ISR so that it no longer contributes to its register usage. Always use the `volatile` qualifier (see [Section 5.4.7.2 “Volatile Type Qualifier”](#)) for variables shared by the interrupt and main-line code; see [Section 3.5.6 “How Do I Share Data Between Interrupt and Main-line Code?”](#).

## 3.6.8 How Big Can C Variables Be?

This question specifically relates to the size of individual C objects, such as arrays or structures. The total size of all variables is another matter.

To answer this question you need to know in which memory space the variable will be located. Objects qualified `const` will be located in program memory; other objects will be placed in data memory. Program memory object sizes are discussed in [Section 5.5.3.1 “Size Limitations of Const Variables”](#). Objects in data memory are broadly grouped into autos and non-autos and the size limitations of these objects, respectively, are discussed in [Section 5.5.2.2.3 “Size Limits of Auto Variables”](#) and [Section 5.5.2.1.2 “Non-Auto Variable Size Limits”](#).

## 3.6.9 How Do I Utilize/Allocate the RAM Banks on My Device?

The compiler will automatically use all the available RAM banks on the device you are programming. It is only if you wish to alter the default memory allocation that you need take any action. Special bank qualifiers; see [Section 5.4.8.4 “Bank0, Bank1, Bank2 and Bank3 Type Qualifiers”](#), and an option (see [Section 4.8.15 “--ADDRQUAL: Set Compiler Response to Memory Qualifiers”](#)) to indicate how these qualifiers are interpreted are used to manually allocate variables.

Note that there is no guarantee that all the memory on a device can be utilized as data and code is packed in sections, or psects.

## 3.6.10 How Do I Utilize the Linear Memory on Enhanced Mid-range PIC Devices?

The linear addressing mode is a means of accessing the banked data memory as one contiguous and linear block; see [Section 5.5.1 “Address Spaces”](#). Use of the linear memory is fully automatic. Objects that are larger than a data bank can be defined in the usual way and will be accessed using the linear addressing mode; see [Section 5.5.2.2.2 “Software Stack Operation”](#), and [Section 5.5.2.1.2 “Non-Auto Variable Size Limits”](#). If you define absolute objects at a particular location in memory, you can use a linear address, if you prefer, or the regular banked address; see [Section 5.5.4.1 “Absolute Variables in Data Memory”](#).

## 3.6.11 What Devices are Supported by the Compiler?

Support for new devices usually takes place with each compiler release. To find whether a device is supported by your compiler, you can do several things; see also, [Section 5.3.1 “Device Support”](#).

- HTML listings are provided in the compiler's docs directory. Open these in your favorite web browser. They are called `pic_chipinfo.html` and `pic18_chipinfo.html`.
- Run the compiler driver on the command line (see [Section 4.2 “Invoking the Compiler”](#)) with the `--CHIPINFO` option; see [Section 4.8.19 “--CHIPINFO: Display List of Supported Devices”](#). A full list of all devices is printed to the screen.

## 3.6.12 How Do I Know What Code the Compiler Is Producing?

The assembly list file (see [Section 6.4 “Assembly List Files”](#)) shows the assembly output for almost the entire program, including library routines linked in to your program, as well as a large amount of the runtime startup code; see [Section 5.10.1 “Runtime Startup Code”](#). The list file is produced by default if you are using MPLAB X IDE. If you are using the command-line, the option `--ASMLIST` will produce this file for you; see [Section 4.8.16 “--ASMLIST: Generate Assembler List Files”](#). The assembly list file will have a `.lst` extension.

The list file shows assembly instructions, some assembly directives and information about the program, such as the call graph (see [Section 6.4.6 “Call Graph”](#)), pointer reference graph (see [Section 6.4.5 “Pointer Reference Graph”](#)), and information for every function. Not all assembly directives are shown in the list file if the assembly optimizers are enabled (they are produced in the intermediate assembly file). Temporarily disable the assembly optimizers (see [Section 4.8.45 “--OPT: Invoke Compiler Optimizations”](#)), if you wish to see all the assembly directives produced by the compiler.

## 3.6.13 How Can I Tell How Big a Function Is?

Information that includes the size of functions is presented in the map file. Look for the header “MODULE INFORMATION” near the bottom of the file. This information is discussed in [Section 7.4.2.8 “Module Information”](#).

## 3.6.14 How Do I Know Which Resources Are Being Used by Each Function?

In the assembly list file there is information printed for every C function, including library functions; see [Section 6.4 “Assembly List Files”](#). This information indicates what registers the function used, what functions it calls (this is also found in the call graph; see [Section 6.4.6 “Call Graph”](#)), and how many bytes of data memory it requires. Note that auto, parameter and temporary variables used by a function can overlap with those from other functions as these are placed in a compiled stack by the compiler; see [Section 5.5.2.2.1 “Compiled Stack Operation”](#).

## 3.6.15 How Do I Find Out Where Variables and Functions Have Been Positioned?

You can determine where variables and functions have been positioned from either the assembly list file, see [Section 6.4 “Assembly List Files”](#); or the map file, see [Section 7.4 “Map Files”](#). Only global symbols are shown in the map file; all symbols (including locals) are listed in the assembly list file, but only for the code represented by that list file. (Each assembly module has its own list file.)

There is a mapping between C identifiers and the symbols used in assembly code, which are the symbols shown in both of these files; see [Section 5.12.3.1 “Equivalent Assembly Symbols”](#). The symbol associated with a variable is assigned the address of the lowest byte of the variable; for functions it is the address of the first instruction generated for that function.

## 3.6.16 Why Are Some Objects Positioned Into Memory That I Reserved?

The memory reservation options (see [Section 3.4.3.6 “How Do I Place a Function Into a Unique Section?”](#)) will adjust the range of addresses associated with classes used by the linker. Most variables and function are placed into psects (see [Section 5.15.1 “Program Sections”](#)) that are linked anywhere inside these class ranges and so are affected by these reservation options.

Some psects are explicitly placed at an address rather than being linked anywhere in an address range, e.g., the psect that holds the code to be executed at Reset is always linked to address 0 because that is where the Reset location is defined to be for 8-bit devices. Such a psect will not be affected by the `--ROM` option, even if you use it to reserve memory address 0. Psects that hold code associated with Reset and interrupts can be shifted using the `--CODEOFFSET` option; see [Section 4.8.21 “--CODEOFFSET: Offset Program Code to Address”](#).

Check the assembly list file (see [Section 6.4 “Assembly List Files”](#)) to determine the names of psects that hold objects and code. Check the linker options in the map file; see [Section 7.4 “Map Files”](#), to see if psects have been linked explicitly or if they are linked anywhere in a class. See also, the linker options `-p` ([Section 7.2.18 “-Pspec”](#)) and `-A` ([Section 7.2.1 “-Aclass =low-high,...”](#)).

## 3.6.17 How Do I Know How Much Memory Is Still Available?

Although the memory summary printed by the compiler after compilation, (see [Section 4.8.61 “--SUMMARY: Select Memory Summary Output Type”](#) options), or the memory display available in MPLAB X IDE both indicate the amount of memory used and the amount still available, neither of these features indicate whether this memory is one contiguous block or broken into many small chunks. Small blocks of free memory cannot be used for larger objects and so out-of-memory errors can be produced even though the total amount of memory free is apparently sufficient for the objects to be positioned. (See [Section 3.7.6 “How Do I Fix a “Can't find space...” Error?”](#).)



The “UNUSED ADDRESS RANGES” section (see [Section 7.4.2.5 “Unused Address Ranges”](#)) in the map file indicates exactly what memory is still available in each linker class. It also indicated the largest contiguous block in that class if there are memory bank or page divisions.

### 3.6.18 How Do I Use Library Files in My Project?

See [Section 3.3.6 “How Do I Build Libraries?”](#) for information on how you build your own library files. The compiler will automatically include any applicable standard library into the build process when you compile, so you never need to control these files.

To use one or more library files that were built by yourself or a colleague, include them in the list of files being compiled on the command line. The library files can be specified in any position in the file list relative to the source files, but if there is more than one library file, they will be searched in the order specified in the command line. The LPP libraries do not need to be specified if you are compiling to an intermediate file, i.e., using the `--PASS1` option (see [Section 4.8.49 “--PASS1: Compile to P-code”](#)). For example:

```
xc8 --chip=16f1937 main.c int.c lcd.lpp
```

If you are using MPLAB X IDE to build a project, add the library file(s) to the Libraries folder that will shown in your project, in the order in which they should be searched. The IDE will ensure that they are passed to the compiler at the appropriate point in the build sequence.

### 3.6.19 What Optimizations Are Employed by the Compiler?

Optimizations are employed at both the C and assembly level of compilation. This is described in [Section 5.13 “Optimizations”](#) and [Section 6.3 “Assembly-Level Optimizations”](#), respectively. The options that control optimization are described in [Section 4.8.45 “--OPT: Invoke Compiler Optimizations”](#).

### 3.6.20 Why Do I Get Out-of-memory Errors When I Select a Debugger?

If you use a hardware tool debugger, such as the REAL ICE or ICD3, these require memory for the on-board debug executive. When you select a debugger using the compiler's `--DEBUGGER` option ([Section 4.8.22 “--DEBUGGER: Select Debugger Type”](#)), or the IDE equivalent, the memory required for debugging is removed from that available to your project. See [Section 3.5.4 “What Do I Need to Do When Compiling to Use a Debugger?”](#)

### 3.6.21 How Do I Know Which Stack Model the Compiler Has Assigned to a Function?

Look in the function information section in the assembly list file, see [Section 6.4.3 “Function Information”](#). The last line of this block will indicate whether the function uses a reentrant or non-reentrant model.

## 3.6.22 How Do I Know What Value Has Been Programmed in the Configuration Bits or ID Location?

Check the file `startup.as` (see [Section 4.8.54 “--RUNTIME: Specify Runtime Environment”](#)). This contains the output of the `#pragma config` directive. You will see the numerical value programmed to the appropriate locations. In the following example, the configuration value programmed is `0xFFBF`. A breakdown of what this value means is also printed.

```
; Config register CONFIG @ 0x2007
;     BOREN = OFF, BOR disabled
; ...
;     PWRT = 0x1, unprogrammed default

psect   config
        org 0x0
        dw 0xFFBF
```



## 3.7 FIXING CODE THAT DOES NOT WORK

This section examines issues relating to projects that do not build due to compiler errors, or those that build, but do not work as expected.

- [How Do I Find Out What an Warning/Error Message Means?](#)
- [How Do I Find the Code that Caused Compiler Errors or Warnings in My Program?](#)
- [How Can I Stop Spurious Warnings From Being Produced?](#)
- [Why Can't I Even Blink an LED?](#)
- [How Do I Know If the Hardware Stack Has Overflowed?](#)
- [How Do I Fix a "Can't find space..." Error?](#)
- [How Do I Fix a "Can't generate code..." Error?](#)
- [How Do I Fix a Fixup Overflow Error?](#)
- [What Can Cause Corrupted Variables and Code Failure When Using Interrupts?](#)

### 3.7.1 How Do I Find Out What an Warning/Error Message Means?

Each warning or error message has a description, and possibly sample code that might trigger such an error, listed in the messages chapter, see [Appendix C. Error and Warning Messages](#). The compiler prints with each message a unique ID number in brackets. Use this number to look up the message in the manual. This number also allows you to control message behavior using options and pragmas, see [Section 4.6.5 "Changing Message Behavior"](#).

### 3.7.2 How Do I Find the Code that Caused Compiler Errors or Warnings in My Program?

In most instances, where the error is a syntax error relating to the source code, the message produced by the compiler indicates the offending line of code, see [Section 4.6 "Compiler Messages"](#). If you are compiling in MPLAB X IDE, then you can double-click the message and have the editor take you to the offending line. But identifying the offending code is not always so easy.

In some instances, the error is reported on the line of code following the line that needs attention. This is because a C statement is allowed to extend over multiple lines of the source file. It is possible that the compiler cannot be able to determine that there is an error until it has started to scan to statement following. So in the following code

```
input = PORTB // oops - forgot the semicolon
if(input>6)
    // ...
```

The missing semicolon on the assignment statement will be flagged on the following line that contains the `if()` statement.

In other cases, the error might come from the assembler, not the code generator. If the assembly code was derived from a C source file then the compiler will try to indicate the line in the C source file that corresponds to the assembly that is at fault. If the source being compiled is an assembly module, the error directly indicates the line of assembly that triggered the error. In either case, remember that the information in the error relates to some problem is the assembly code, not the C code.

Finally, there are errors that do not relate to any particular line of code at all. An error in a compiler option or a linker error are examples of these. If the program defines too many variables, there is no one particular line of code that is at fault; the program as a whole uses too much data. Note that the name and line number of the last processed file and source can be printed in some situations even though that code is not the direct source of the error.

To determine the application that generated the error or warning, take a note of its unique number printed in the message, see [Section 4.6.1 “Messaging Overview”](#), and check the message section of the manual, see [Appendix C. Error and Warning Messages](#). At the top of each message description, on the right in brackets, is the name of the application that produced this message. Knowing the application that produced the error makes it easier to track down the problem. The compiler application names are indicated in [Section 4.3 “The Compilation Sequence”](#). If you need to see the assembly code generated by the compiler, look in the assembly list file, see [Section 6.4 “Assembly List Files”](#). For information on where the linker attempted to position objects, see the map file discussed in [Section 7.4 “Map Files”](#).

### 3.7.3 How Can I Stop Spurious Warnings From Being Produced?

Warnings indicate situations that could possibly lead to code failure. In many situations the code is valid and the warning is superfluous. Always check your code to confirm that it is not a possible source of error and in cases where this is so, there are several ways that warnings can be hidden.

- The warning level threshold can be adjusted so that only warnings of a certain importance are printed, see [Section 4.6.5.1 “Disabling Messages”](#)
- All warnings with a specified ID can be inhibited
- In some situations, a pragma can be used to inhibit a warning with a specified ID for certain lines of source code, see [Section 5.14.4.11 “The #pragma warning Directive”](#).

### 3.7.4 Why Can't I Even Blink an LED?

Even if you have set up the TRIS register and written a value to the port, there are several things that can prevent such a seemingly simple program from working.

- Make sure that the device's Configuration registers are set up correctly, see [Section 5.3.5 “Configuration Bit Access”](#). Make sure that you explicitly specify every bit in these registers and don't just leave them in their default state. All the configuration features are described in your device data sheet. If the Configuration bits that specify the oscillator source are wrong, for example, the device clock cannot even be running.
- If the internal oscillator is being used, in addition to Configuration bits there can be SFRs you need to initialize to set the oscillator frequency and modes, see [Section 5.3.6 “Using SFRs From C Code”](#) and your device data sheet.
- Either turn off the Watch Dog Timer in the Configuration bits or clear the Watch Dog Timer in your code (see [Section Appendix A. “Library Functions”](#)) so that the device does not reset. If the device is resetting, it can never reach the lines of code in your program that blink the LED. Turn off any other features that can cause device Reset until your test program is working.
- The device pins used by the port bits are often multiplexed with other peripherals. A pin might be connected to a bit in a port, or it might be an analog input, or it might be the output of a comparator, for example. If the pin connected to your LED is not internally connected to the port you are using, then your LED will never operate as expected. The port function tables shown in your device data sheets will show other uses for each pin that will help you identify peripherals to investigate.

- Make sure you do not have a “read-modify-write” problem. If the device you are using does not have a separate “latch” register (as is the case with mid-range PIC devices) this problem can occur, particularly if the port outputs are driving large loads, such as an LED. You can see that setting one bit turns off another or other unusual events. Create your own latch by using a temporary variable. Rather than read and write the port directly, make modifications to the latch variable. After modifications are complete, copy the latch as a whole to the port. This means you are never reading the port to modify it. Check the device literature for more detailed information.

### 3.7.5 How Do I Know If the Hardware Stack Has Overflowed?

An 8-bit PIC device has a limited hardware stack that is used only for function (and interrupt function) return addresses, see [Section 5.3.4 “Stacks”](#). If the nesting of function calls and interrupts is too deep, the stack will overflow (wraps around and overwrites previous entries). Code will then fail at a later point – sometimes much later in the call sequence – when it accesses the corrupted return address.

The compiler attempts to track stack depth and, when required, swap to a method of calling that does not need the hardware stack (PIC10/12/16 devices only). You have some degree of control over what happens when the stack depth has apparently overflowed, see [Section 4.8.54 “--RUNTIME: Specify Runtime Environment”](#) and the `stackcall` suboption.

A call graph shows the call hierarchy and depth that the compiler has determined. This graph is shown in the assembly list file. To understand the information in this graph, see [Section 6.4.6 “Call Graph”](#).

Since the runtime behavior of the program cannot be determined by the compiler, it can only assume the worst case and can report that overflow is possible even though it is not. However, no overflow should go undetected if the program is written entirely in C. Assembly code that uses the stack is not considered by the compiler and this must be taken into account.

### 3.7.6 How Do I Fix a “Can’t find space...” Error?

There are a number of different variants of this message, but all essentially imply a similar situation. They all relate to there being no free space large enough to place a block of data or instructions. Due to memory paging, banking or other fragmentation, this message can be issued when seemingly there is enough memory remaining. See [Appendix C. Error and Warning Messages](#) for more information on your particular error number.

### 3.7.7 How Do I Fix a “Can’t generate code...” Error?

This is a catch-all message which is generated if the compiler has exhausted all possible means of compiling a C expression, see [Appendix C. Error and Warning Messages](#). It does not usually indicate a fault in your code. The inability to compile the code can be a deficiency in the compiler, or an expression that requires more registers or resources than are available at that point in the code. This is more likely to occur on baseline devices. In any case, simplifying the offending expression, or splitting a statement into several smaller statements, usually allows the compilation to continue. You may need to use another variable to hold the intermediate results of complicated expressions.

## 3.7.8 How Do I Fix a Fixup Overflow Error?

Fixup – the linker action of replacing a symbolic reference with an actual address – can overflow if the address assigned to the symbol is too large to fit in the address field of an assembly instruction. Most 8-bit PIC assembly instructions specify a file address that is an offset into the currently selected memory bank. If a full unmasked address is specified with these instructions, the linker will be unable to encode the large address value into the instruction and this error will be generated. For example, a mid-range device instruction only allows for file addresses in the range of 0 to 0x7F. However, if such a device has 4 data banks of RAM, the addresses of variables can range from 0 to 0x1FF.

For example, if the symbol of a variable that will be located at address 0x1D0 has been specified with one of these instructions, then when the symbol is replaced with its final value, this value will not fit in the address field of the instruction.

Many of the jump and call instructions also take a destination operand that is a truncated address. (The PIC18 CALL and GOTO instructions work with a full address, but the branch and relative call instructions do not.) If the destination label to any of these instructions is not masked, a fixup error can result.

The fixup process applies to the operands of assembler directives, as well as instructions; so if the operand to a directive overflows, a fixup error can also result. For example, if the symbol `error` is resolved by the linker to be the value 0x238, the directive:

```
DB error
```

which expects a byte value, will generate a fixup overflow error.

In most cases, fixup errors are caused by hand-written assembly code. When writing assembly, it is the programmer's responsibility to add instructions to select the destination bank or page, and then mask the address being used in the instruction (see [Section 3.4.7.5 "What Things Must I Manage When Writing Assembly Code?"](#)).

In some situations assembly code generated from C code can produce a fixup overflow message. Typically this will be related to jumps that are out of range. C `switch` statements that have become too large can trigger such a message. Changing how a compiler-generated psect is linked can also cause fixup overflow, as the new psect location may break an assumption made by the compiler.

It is important to remember that this is an issue with an assembly instruction, and that you need to find the instruction at fault before you can proceed. See the relevant error number in [Appendix C. Error and Warning Messages](#) for specific details about how to track down the offending instruction.

## 3.7.9 What Can Cause Corrupted Variables and Code Failure When Using Interrupts?

This is usually caused by having variables used by both interrupt and main-line code. If the compiler optimizes access to a variable or access is interrupted by an interrupt routine, then corruption can occur. See [Section 3.5.6 "How Do I Share Data Between Interrupt and Main-line Code?"](#) for more information.

---

---

## Chapter 4. XC8 Command-line Driver

---

---

### 4.1 INTRODUCTION

The name of the command-line driver is `xc8`. MPLAB XC8 can be invoked to perform all aspects of compilation, including C code generation, assembly, and link steps. Even if an IDE is used to assist with compilation, the IDE will ultimately call `xc8`.

Although the internal compiler applications can be called explicitly from the command line, the `xc8` driver is the recommended way to use the compiler as it hides the complexity of all the internal applications used and provides a consistent interface for all compilation steps.

This chapter describes the steps that the driver takes during compilation, the files that the driver can accept and produce, as well as the command-line options that control the compiler's operation. The relationship between these command-line options and the controls in the MPLAB X IDE Build Options dialog is also described.

The following topics are examined in this chapter of the MPLAB XC8 C Compiler User's Guide:

- [Invoking the Compiler](#)
- [The Compilation Sequence](#)
- [Runtime Files](#)
- [Compiler Output](#)
- [Compiler Messages](#)
- [MPLAB XC8 Driver Options](#)
- [MPLAB X Option Equivalents](#)

## 4.2 INVOKING THE COMPILER

This section explains how to invoke `xc8` on the command line, as well as the files that it can read.

### 4.2.1 Driver Command-line Format

The `xc8` driver has the following basic command format:

```
xc8 [options] files [libraries]
```

Throughout this manual, it is assumed that the compiler applications are in the console's search path or that the full path is specified when executing an application. The compiler's location can be added to the search path when installing the compiler by selecting the [Add to environment](#) checkbox at the appropriate time during the installation.

It is customary to declare *options* (identified by a leading dash "-" or double dash "--") before the files' names. However, this is not mandatory.

The formats of the options are supplied in [Section 4.7 "MPLAB XC8 Driver Options"](#), along with corresponding descriptions of the options.

The *files* can be an assortment of C and assembler source files, and precompiled intermediate files, such as relocatable object (`.obj`) files or p-code (`.p1`) files. While the order in which the files are listed is not important, it can affect the order in which code or data appears in memory, and can affect the name of some of the output files.

*Libraries* is a list of user-defined object code or p-code library files that will be searched by the code generator (in the case of p-code libraries) or the linker (for object code libraries), in addition to the standard C libraries. The order of these files will determine the order in which they are searched. It is customary to insert the *Libraries* list after the list of source file names. However, this is not mandatory.

If you are building code using a make system, familiarity with the unique intermediate p-code file format, as described in [Section 4.3.3 "Multi-Step Compilation"](#), is recommended. Object files are seldom used with the MPLAB XC8 C Compiler, unless assembly source modules are in the project.

#### 4.2.1.1 LONG COMMAND LINES

The `xc8` driver is capable of processing command lines exceeding any operating system limitation if the driver is passed options via a command file. The command file is specified by the `@` symbol, which should be immediately followed (i.e., no intermediate space character) by the name of the file containing the command-line arguments that are intended for the driver. The same system of argument passing is used by all the applications called by the compiler driver.

Each command-line argument must be separated by one or more spaces and can be extended to several lines by using a space and backslash character to separate lines. The file can contain blank lines, which are simply skipped by the driver.

Compiler options and source code filenames can be permanently stored in command files without the complexity of creating a make utility.

In the following example, a command file `xyz.xc8` was constructed in a text editor to contain both the options and the file names that are required to compile a project.

```
--chip=16F877A -m \  
--opt=all -g \  
main.c isr.c
```

After it is saved, the compiler can be invoked with the following command:

```
xc8 @xyz.xc8
```

## 4.2.2 Environment Variables

When hosted on a Windows environment, the compiler uses the registry to store information relating to the compiler installation directory and activation details, along with other configuration settings. That information is required whether the compiler is run on the command line or from within an IDE.

Under Linux<sup>®</sup> and Mac OS<sup>®</sup> X environments, the registry is replaced by an XML file that stores the same information.

On non-Windows hosts, the compiler searches for the XML file in the following ways:

1. The compiler looks for the presence of an environment variable called `XC_XML`. If present, this variable should contain the full path to the XML file (including the file's name).
2. If this variable is not defined, the compiler then searches for an environment variable called `HOME`. This variable typically contains the path to the user's home directory. The compiler looks for the XML with a name `.xc.xml` in the directory indicated by the `HOME` variable.
3. If the `HOME` environment variable is not defined, the compiler tries to open the file `/etc/xc.xml`.
4. If none of these methods finds the XML file, an error is generated.

When running the compiler on the command line, you can wish to set the `PATH` environment variable. This allows you to run the compiler driver without specifying the full compiler path with the driver name. Note that the directories specified by the `PATH` variable are only used to locate the compiler driver. Once the driver is running, it uses the registry or XML file, described above, to locate the internal compiler applications, such as the parser, assembler and linker, etc. The directories specified in the `PATH` variable do not override the information contained in the registry or XML file. The MPLAB X IDE allows the compiler to be selected via a dialog and execution of the compiler does not depend on the `PATH` variable.

## 4.2.3 Input File Types

xc8 distinguishes source files, intermediate files, and library files solely by the file type, or extension. Recognized file types are listed in [Table 4-1](#). Alphabetic case of the extension is not important from the compiler's point of view, but most operating system shells are case sensitive.

**TABLE 4-1:** xc8 INPUT FILE TYPES

File Type	Meaning
.c	C source file
.p1	p-code file
.lpp	p-code library file
.as or .asm	Assembler source file
.obj	Relocatable object code file
.lib	Relocatable object library file
.hex	Intel HEX file

This means, for example, that a C source file must have a .c extension. Assembler files can use either .as or .asm extensions.

There are no compiler restrictions imposed on the names of source files, but be aware of case, name-length, and other restrictions that are imposed by your operating system. Never use the same base name for assembly and C source files, even if they are located in different directories; the name of the intermediate file produced from the C source file might conflict with that of the assembly source file. If you are using an IDE, avoid assembly source files whose base name is the same as the base name of any project in which the file is used. This can result in the source file being overwritten by a temporary file during the build process.

The terms “source file” and “module” are often used when talking about computer programs. They are often used interchangeably, but they refer to the source code at different points in the compilation sequence.

A source file is a file that contains all or part of a program. They can contain C code, as well as preprocessor directives and commands. Source files are initially passed to the preprocessor by the driver.

A module is the output of the preprocessor, for a given source file, after inclusion of any header files (or other source files) which are specified by `#include` preprocessor directives. All preprocessor directives and commands (with the exception of some commands for debugging) have been removed from these files. These modules are then passed to the remainder of the compiler applications. Thus, a module can be the amalgamation of several source and header files. A module is also often referred to as a translation unit. These terms can also be applied to assembly files, as they can include other header and source files.



## 4.3 THE COMPILATION SEQUENCE

When you compile a project, many internal applications are called to do the work. This section looks at when these internal applications are executed, and how this relates to the build process of multiple source files. This section should be of particular interest if you are using a make system to build projects.

### 4.3.1 The Compiler Applications

The main internal compiler applications and files are illustrated in [Figure 4-1](#).

You can consider the large underlying box to represent the whole compiler, which is controlled by the command line driver, `xc8`. You can be satisfied just knowing that C source files (shown on the far left) are passed to the compiler and the resulting output files (shown here as a HEX and COFF debug file on the far right) are produced; however, internally there are many applications and temporary files being produced. An understanding of the internal operation of the compiler, while not necessary, does assist with using the tool.

To simplify the compiler design, some of the internal applications come in a PIC18 and PIC10/12/16 variant. The appropriate application is executed based on the target device. In fact, the `xc8` driver delegates the build commands to one of two command-line drivers: `PICC` or `PIC18`. This operation is transparent and `xc8` can be considered as “the driver” which does all the work.

The driver will call the required compiler applications. These applications are shown as the smaller boxes inside the large driver box. The temporary file produced by each application can also be seen in this diagram.

**FIGURE 4-1: COMPILER APPLICATIONS AND FILES**

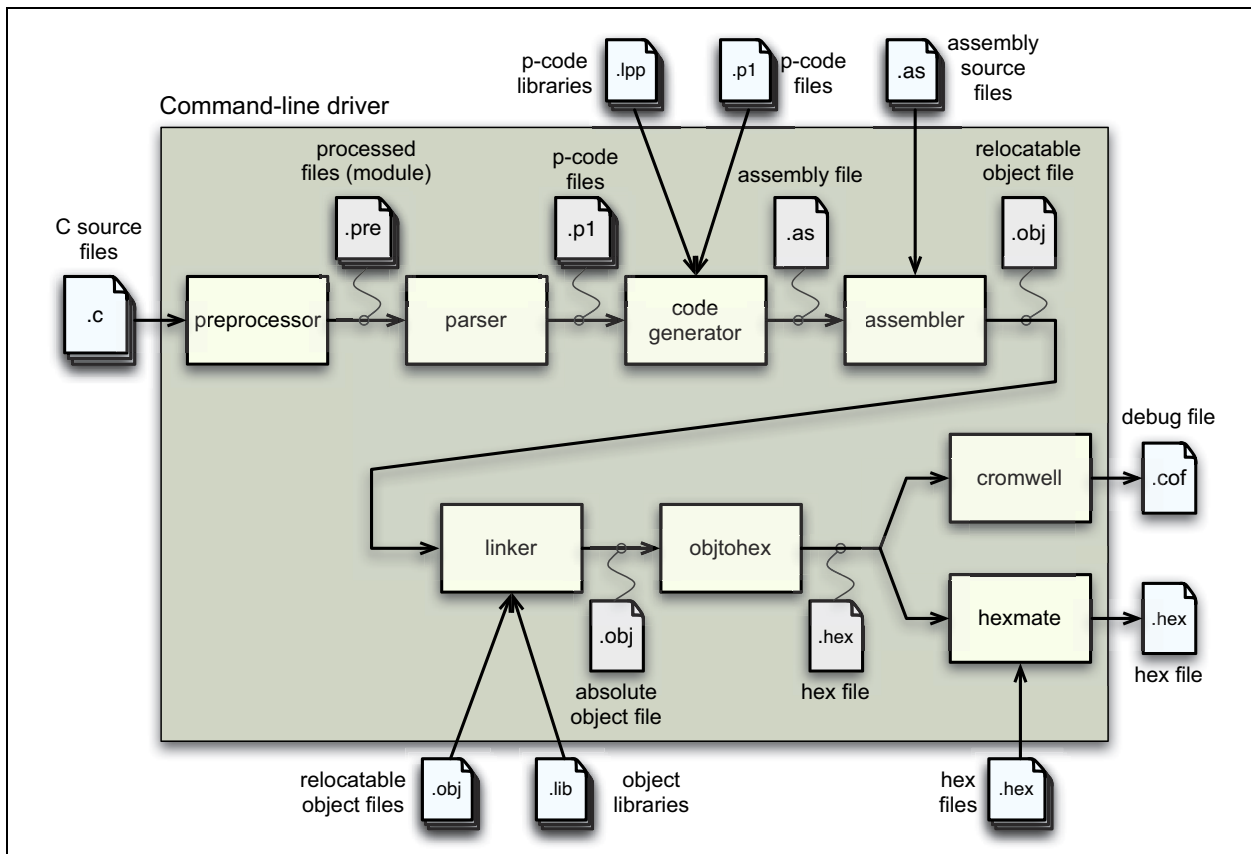

Table 4-2 lists the compiler applications. The names shown are the names of the executables, which can be found in the `bin` directory under the compiler's installation directory.

**TABLE 4-2: COMPILER APPLICATION NAMES**

Name	Description
<code>xc8</code> (calls <code>PICC</code> or <code>PICC18</code> )	Command line driver; the interface to the compiler
<code>CLIST</code>	Text file formatter
<code>CPP</code>	The C preprocessor
<code>P1</code>	C code parser
<code>CGPIC</code> or <code>CGPIC18</code>	Code generator (based on the target device)
<code>ASPIC</code> or <code>ASPIC18</code>	Assembler (based on the target device)
<code>HLINK</code>	Linker
<code>OBJTOHEX</code>	Conversion utility to create HEX files
<code>CROMWELL</code>	Debug file converter
<code>HEXMATE</code>	HEX file utility
<code>LIBR</code>	Librarian
<code>DUMP</code>	Object file viewer

For example, C source files (`.c` files) are first passed to the C preprocessor, `CPP`. The output of this application is `.pre` files. These files are then passed to the parser application, `P1`, which produces a p-code file output with extension `.p1`. The applications are executed in the order specified and temporary files are used to pass the output of one application to the next.

The compiler can accept more than just C source files. Table 4-1 lists all the possible input file types, and these files can be seen in this diagram, on the top and bottom, being passed to different compilation applications. They are processed by these applications and then the application output joins the normal flow indicated in the diagram.

For example, assembly source files are passed straight to the assembler application<sup>1</sup> and are not processed at all by the code generator. The output of the assembler (an object file with `.obj` extension) is passed to the linker in the usual way. You can see that any p-code files (`.p1` extension) or p-code libraries (`.lpp` extension) that are supplied on the command line are initially passed to the code generator.

Other examples of input files include object files (`.obj` extension) and object libraries (`.lib` extension), both of which are passed initially to the linker, and even HEX files (`.hex` extension), which are passed to one of the utility applications, called `HEXMATE`, which is run right at the end of the compilation sequence.

Some of the temporary files shown in this diagram are actually preserved and can be inspected after compilation has concluded. There are also driver options to request that the compilation sequence stop after a particular application and the output of that application becomes the final output.

---

1. Assembly file will be preprocessed before being passed to the assembler if the `-P` option is selected.

**FIGURE 4-2: MULTI-FILE COMPILATION**

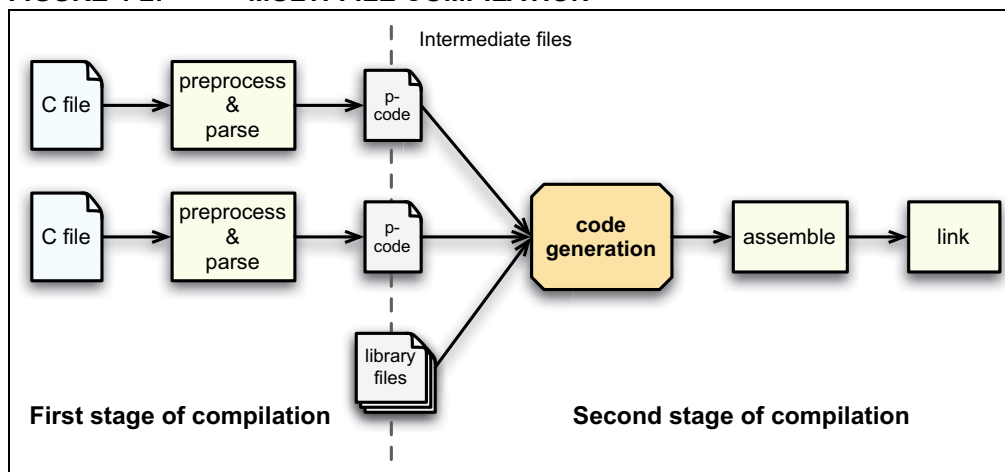

### 4.3.2 Single-Step Compilation

Figure 4-1 showed us the files that are generated by each application and the order in which these applications are executed. However this does not indicate how these applications are executed when there is more than one source file being compiled.

Consider the case when there are two C source files that form a complete project and that are to be compiled, as is the case shown in Figure 4-2. If these files are called `main.c` and `io.c`, these could be compiled with a single command, such as:

```
xc8 --chip=16F877A main.c io.c
```

This command will compile the two source files all the way to the final output, but internally we can consider this compilation as consisting of two stages.

The first stage involves processing of each source file separately, and generating some sort of intermediate file for each source file. The second stage involves combining all these intermediate files and further processing to form the final output. An intermediate file is a particular temporary file that is produced and marks the midpoint between the first and second stage of compilation.

The intermediate file used by `xc8` is the p-code (`.p1` extension) file output by the parser, so there will be one p-code file produced for each C source file. As indicated in the diagram, `CPP` and then `P1` are executed to form this intermediate file. (For clarity, the `CPP` and `P1` applications have been represented by the same block in the diagram.)

In the second stage, the code generator reads in all the intermediate p-code files and produces a single assembly file output, which is then passed to the subsequent applications that produce the final output.

The desirable attribute of this method of compilation is that the code generator, which is the main application that transforms from the C to the assembly domain, sees the entire project source code via the intermediate files.

Traditional compilers have always used intermediate files that are object files output by the assembler. These intermediate object files are then combined by the linker and further processed to form the final output. This method of compilation is shown in Figure 4-3. It shows that the code generator is executed once for each source file. So, the code generator can only analyze that part of the project that is contained in the source file that is currently being compiled. The MPLAB XC16 and XC32 compilers work in this fashion.

Using object files as the intermediate file format with MPLAB XC8 C Compiler will defeat many features the compiler uses to optimize code. Always use p-code files as the intermediate file format if you are using a make system to build projects.

FIGURE 4-3: THE TRADITIONAL COMPILATION SEQUENCE

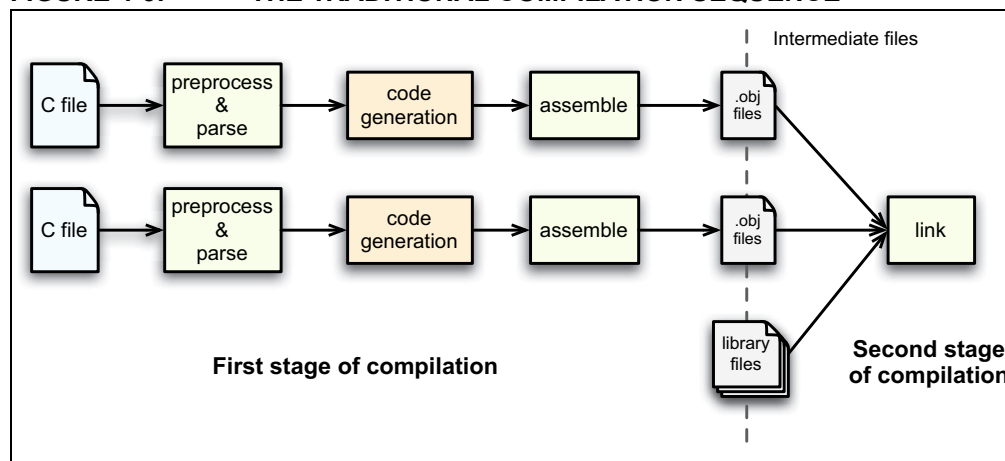

When compiling files of mixed types, this can still be achieved with just one invocation of the compiler driver. As discussed in [Section 4.3 “The Compilation Sequence”](#), the driver will pass each input file to the appropriate compiler application.

For example, the files, `main.c`, `io.c`, `mdef.as` and `c_sb.lpp` are to be compiled. To perform this in a single step, the following command line could be used.

```
xc8 --chip=16F877A main.c io.c mdef.as c_sb.lpp
```

As shown in [Figure 4-1](#) and [Figure 4-2](#), the two C files (`main.c` and `io.c`) will be compiled to intermediate p-code files; these, along with the p-code library file (`c_sb.lpp`) will be passed to the code generator. The output of the code generator, as well as the assembly source file (`mdef.as`), will be passed to the assembler.

The driver will recompile all source files, regardless of whether they have changed since the last build. IDEs (such as MPLAB® IDE) and make utilities must be employed to achieve incremental builds. See also, [Section 4.3.3 “Multi-Step Compilation”](#).

Unless otherwise specified, a HEX file and Microchip COFF file are produced as the final output. All intermediate files remain after compilation has completed, but most other temporary files are deleted, unless you use the `--NODEL` option (see [Section 4.8.42 “--NODEL: Do Not Remove Temporary Files”](#)) which preserves all generated files except the run-time start-up file. Note that some generated files can be in a different directory than your project source files. See [Section 4.8.46 “--OUTDIR: Specify a Directory for Output Files”](#), and [Section 4.8.44 “--OBJDIR: Specify a Directory for Intermediate Files”](#), which can both control the destination for some output files.

## 4.3.3 Multi-Step Compilation

Make utilities and IDEs, such as MPLAB X IDE, allow for an incremental build of projects that contain multiple source files. When building a project, they take note of which source files have changed since the last build and use this information to speed up compilation.

For example, if compiling two source files, but only one has changed since the last build, the intermediate file corresponding to the unchanged source file need not be regenerated.

MPLAB X IDE is aware of the different compilation sequence employed by `xc8` and takes care of this for you. From MPLAB X IDE you can select an incremental build (Build Project icon), or fully rebuild a project (Clean and Build Project icon).

If the compiler is being invoked using a make utility, the make file will need to be configured to recognize the different intermediate file format and the options used to generate the intermediate files. Make utilities typically call the compiler multiple times: once for each source file to generate an intermediate file, and once to perform the second stage compilation.

You might also wish to generate intermediate files to construct your own library files. However, `xc8` is capable of constructing libraries in a single step, so this is typically not necessary. See [Section 4.8.47 “--OUTPUT= type: Specify Output File Type”](#) for more information on library creation.

The option `--PASS1` (see [Section 4.8.48 “--PARSER: Specify Parser Mode”](#)) is used to tell the compiler that compilation should stop after the parser has executed. This will leave the p-code intermediate file behind on successful completion.

For example, the files `main.c` and `io.c` are to be compiled using a make utility. The command lines that the make utility should use to compile these files might be something like:

```
xc8 --chip=16F877A --pass1 main.c
xc8 --chip=16F877A --pass1 io.c
xc8 --chip=16F877A main.pl io.pl
```

It is important to note that the code generator needs to compile all p-code or p-code library files associated with the project in the one step. When using the `--PASS1` option, the code generator is not being invoked; so the above command lines do not violate this requirement.

Using object files as the intermediate file format with MPLAB XC8 C Compiler will defeat many features the compiler uses to optimize code. Always use p-code files as the intermediate file format if you are using a make system to build projects.

## 4.3.4 Compilation of Assembly Source

Since the code generator performs many tasks that were traditionally performed by the linker, there could be complications when assembly source is present in a project. Assembly files are traditionally processed after C code, but it is necessary to have this performed first so that specific information contained in the assembly code can be conveyed to the code generator.

The specific information passed to the code generator is discussed in more detail in [Section 5.12.3 “Interaction between Assembly and C Code”](#).

When assembly source is present, the order of compilation is as shown in [Figure 4-4](#).

**FIGURE 4-4: COMPILATION SEQUENCE WITH ASSEMBLY FILES**

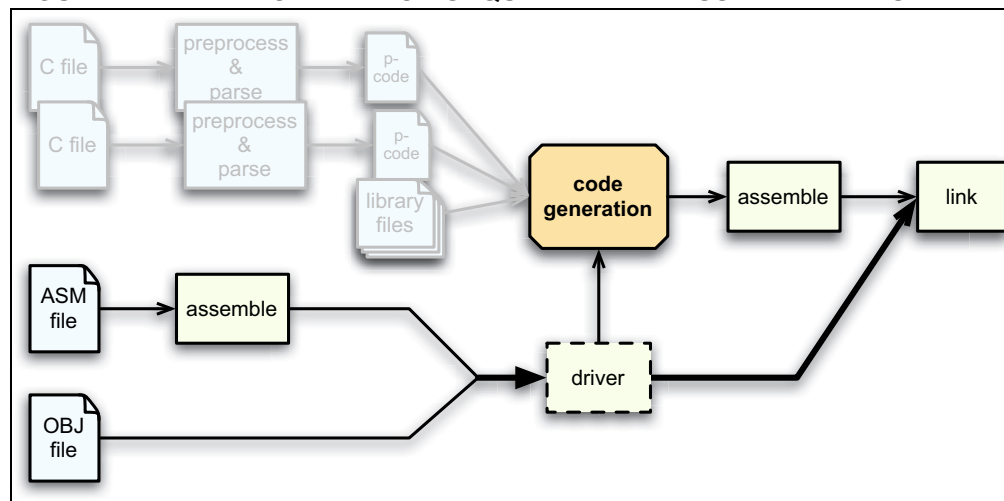

First, any assembly source files are assembled to form object files. These files, along with any other objects files that are part of the project, are scanned by the command-line driver and the information is passed to the code generator; where it subsequently builds the C files, as has been described earlier.

### 4.3.4.1 INTERMEDIATE FILES AND ASSEMBLY SOURCE

The intermediate file format associated with assembly source files is the same as that used in traditional compilers; i.e., an object file (.obj extension). Assembly files are never passed to the code generator and so the code generator technology does not alter the way these files are compiled.

The `-C` option (see [Section 4.8.1 “-C: Compile to Object File”](#)) is used to generate object files and to halt compilation after the assembly step.

## 4.3.5 Printf Check

An extra execution of the code generator is performed prior to the actual code generation phase. This pass is part of the process by which the `printf` library function is customized, see [Section 5.12 “Mixing C and Assembly Code”](#), for more details.

This pass is only associated with scanning the C source code for `printf` placeholder usage and you will see the code generator being executed if you select the verbose option when you build, see [Section 4.8.14 “-V: Verbose Compile”](#).

## 4.4 RUNTIME FILES

In addition to the C and assembly source files specified on the command line, there are also compiler-generated source files and pre-compiled library files which might be compiled into the project by the driver. These files are discussed in the following sections.

### 4.4.1 Library Files

The names of the C standard library files appropriate for the selected target device are determined by the driver and passed to the code generator and linker. You do not need to manually include library files into your project.

Most library routines are derived from p-code library files (`.lpp` libraries) which the compiler will search for in the `lib` directory under the compiler installation directory.

The name format for the standard libraries is `family-type-options.lpp`, where the following apply.

- `family` can be `pic18` for PIC18 devices, or `pic` for all other 8-bit PIC devices
- `type` indicates the sort of library functionality provided and can be `stdlib` for the standard library functions, or `trace`, etc.
- `options` indicates hyphen-separated names to indicate variants of the library to accommodate different compiler options or modes, e.g., `htc` for the default flavor of C used by MPLAB XC8, `d32` for 32-bit doubles, etc.

For example, the standard library for baseline and midrange devices using 24-bit double types is `pic-stdlib-d24.lpp`.

For more information on libraries, see [Section 5.11 “Libraries”](#).

### 4.4.2 Startup and Initialization

A C program requires certain objects to be initialized and the device to be in a particular state before it can begin execution of its function `main`. It is the job of the *runtime startup* code to perform these tasks. [Section 5.10.1 “Runtime Startup Code”](#) details the specific actions taken by this code and how it interacts with programs you write.

Rather than the traditional method of linking in a generic, precompiled routine, the MPLAB XC8 C Compiler determines what runtime startup code is required from the user's program and then generates this code each time you build.

The file created by the driver can be deleted after compilation, but this operation can be controlled with the `keep` suboption to the `--RUNTIME` option. The default operation of the driver is to keep the startup module; however, if using MPLAB X IDE to build, the file will be deleted unless you indicate otherwise in the Project Properties dialog.

If the startup module is kept, it will be called `startup.as` and will be located in the current working directory. If you are using an IDE to perform the compilation, the destination directory can be dictated by the IDE itself. MPLAB X IDE stores this file in the `dist/default/production(debug)` directory in your project directory.

Generation of the runtime startup code is an automatic process that does not require any user interaction; however, some aspects of the runtime code can be controlled, if required, using the `--RUNTIME` option. [Section 4.8.54 “--RUNTIME: Specify Runtime Environment”](#) describes the use of this option.

The runtime startup code is executed before `main`. However, if you require any special initialization to be performed immediately after Reset, you should use the `powerup` feature described later in [Section 5.10.2 “The Powerup Routine”](#).



## 4.5 COMPILER OUTPUT

There are many files created by the compiler during the compilation. A large number of these are intermediate files. Some are deleted after compilation is complete, but many remain and are used for programming the device, or for debugging purposes.

### 4.5.1 Output Files

The names of many output files use the same base name as the source file from which they were derived. For example, the source file `input.c` will create a p-code file called `input.pl`.

Some of the output files contain project-wide information and are not directly associated with any one particular input file, e.g., the map file. If the names of these output files are not specified by a compiler option, their base name is derived from the first C source file listed on the command line. If there are no files of this type specified, the name is based on the first input file (regardless of type) on the command line.

If you are using an IDE, such as MPLAB X IDE, to specify options to the compiler, there is typically a project file that is created for each application. The name of this project is used as the base name for project-wide output files, unless otherwise specified by the user. However, check the manual for the IDE you are using, for more details.

**Note:** Throughout this manual, the term *project name* will refer to either the name of the project created in the IDE, or the base name (file name without extension) of the first C source file specified on the command line.

The compiler is directly able to produce a number of the output file formats that are used by the 8-bit PIC development tools.

The default behavior of `xc8` is to produce a Microchip format COFF and Intel HEX output. Unless changed by a driver option, the base names of these files will be the project name. The default output file types can be controlled by compiler options, e.g., the `--OUTPUT` option. The extensions used by these files are fixed and are listed together with this option's description in [Section 4.8.47 "--OUTPUT= type: Specify Output File Type"](#).

The COFF file is used by debuggers to obtain debugging information about the project. The compiler can produce ELF/DWARF debugger files, although these are not compatible with MPLAB 8 IDE and early versions of MPLAB X IDE. You must specifically select ELF output for these files to be produced. ELF/DWARF files allow for more accurate debugging. Use of these files correct several COFF-related issues that prevent you from correctly viewing objects, in particular pointer variables, in the IDE. Ensure the IDE version you are using supports ELF before selecting this option.

[Table 4-17](#) shows all output format options available with `xc8` using the `--OUTPUT` option. The File Type column lists the filename extension that is used for the output file.

#### 4.5.1.1 SYMBOL FILES

By default, `xc8` creates symbol files that are used to generate the debug output files, such as COFF and ELF files. These files include a SYM file (`.sym` extension) and a CMF file (`.cmf` extension), and both are produced by the linker. In addition, there is a SDB file (`.sdb` extension) produced by the code generator.

The SDB file contains type information, and the SYM and CMF files contain address information. The SDB and SYM/CMF files, in addition to the HEX file, are combined by the `CROMWELL` application to produce the output debug files, such as the COFF file.

The CMF file largely replaces the older SYM file format. They contain similar information, but CMF files are more detailed and enable more accurate debug files to be generated.



## 4.5.2 Diagnostic Files

Two valuable files produced by the compiler are the assembly list file, produced by the assembler, and the map file, produced by the linker.

The compiler options `--ASMLIST` (see [Section 4.8.15 "--ADDRQUAL: Set Compiler Response to Memory Qualifiers"](#)) generates a list file, and the `-M` option (see [Section 4.8.7 "-M: Generate Map File"](#)) specifies generation of a map file.

The assembly list file contains the mapping between the original source code and the generated assembly code. It is useful for information such as how C source was encoded, or how assembly source can have been optimized. It is essential when confirming if compiler-produced code that accesses objects is atomic, and shows the psects in which all objects and code are placed. For an introductory guide to psects, see [Section 5.15.1 "Program Sections"](#). Also, see [Section 6.3 "Assembly-Level Optimizations"](#), for more information on the contents of this file.

There is one list file produced for the entire C program, including C library files. It is assigned the project name and the extension `.lst`. One additional list file is produced for each assembly source file compiled in the project.

The map file shows information relating to where objects were positioned in memory. It is useful for confirming if user-defined linker options were correctly processed, and for determining the exact placement of objects and functions. It also shows all the unused memory areas in a device and memory fragmentation. See [Section 7.4 "Map Files"](#), for complete information on the contents of this file.

There is one map file produced when you build a project, assuming the linker was executed and ran to completion. The file is assigned the project name and a `.map` extension.

## 4.6 COMPILER MESSAGES

All compiler applications, including the command-line driver, `xc8`, use textual messages to report feedback during the compilation process. A centralized messaging system is used to produce the messages, which allows consistency during all stages of the compilation process. The messaging system is described in this section and a complete list of all warning and error messages can be found in [Appendix C. Error and Warning Messages](#).

### 4.6.1 Messaging Overview

A message is referenced by a unique number that is passed to the messaging system by the compiler application that needs to convey the information. The message string corresponding to this number is obtained from Message Description Files (MDF), which are stored in the `dat` directory in the compiler's installation directory.

When a message is requested by a compiler application, its number is looked up in the MDF that corresponds to the currently selected language. The language of messages can be altered as discussed in [Section 4.6.2 "Message Language"](#).

Once found, the alert system can read the message type and the string to be displayed from the MDF. Several different message types are described in [Section 4.6.3 "Message Type"](#); and the type can be overridden by the user, as described in that same section.

The user is also able to set a threshold for warning message importance, so that only those that the user considers significant will be displayed. In addition, messages with a particular number can be disabled. A pragma can also be used to disable a particular message number within specific lines of code. These methods are explained in [Section 4.6.5.1 "Disabling Messages"](#).

Provided the message is enabled and it is not a warning message whose level is below the current warning threshold, the message string will be displayed.

In addition to the actual message string, there are several other pieces of information that can be displayed, such as the message number, the name of the file for which the message is applicable, the file's line number and the application that issued the message, etc.

If a message is an error, a counter is incremented. After a specific amount of errors has been reached, compilation of the current module will cease. The default number of errors that will cause this termination can be adjusted by using the `--ERRORS` option, see [Section 4.8.29 "--ERRORS: Maximum Number of Errors"](#). This counter is reset for each internal compiler application, thus specifying a maximum of five errors will allow up to five errors from the parser, five from the code generator, five from the linker, five from the driver, etc.

Although the information in the MDF can be modified with any text editor, this is not recommended. Message behavior should only be altered using the options and pragmas described in the following sections.

## 4.6.2 Message Language

The xc8 driver supports more than one language for displayed messages. There is one MDF for each language supported.

Under Windows® operating system, the default language can be specified when installing the compiler.

The default language can be changed on the command line using the `--LANG` option, see [Section 4.8.36 "--LANG: Specify the Language for Messages"](#). Alternatively, it can be changed permanently by using the `--LANG` option together with the `--SETUP` option which will store the default language in either the registry, under Windows, or in the XML configuration file on other systems. On subsequent builds, the default language used will be that specified.

[Table 4-3](#) shows the MDF applicable for the currently supported languages.

**TABLE 4-3: SUPPORTED LANGUAGES**

Language	MDF name
English	en_msgs.txt
German	de_msgs.txt
French	fr_msgs.txt

If a language other than English is selected, and the message cannot be found in the appropriate non-English MDF, the alert system tries to find the message in the English MDF. If an English message string is not present, a message is displayed that is similar to this one:

```
error/warning (*) generated, but no description available
```

where \* indicates the message number that was generated that will be printed; otherwise, the message in the requested language will be displayed.

## 4.6.3 Message Type

There are four types of messages. These are described below. The behavior of the compiler when encountering a message of each type is also listed.

<b>Advisory Messages</b>	convey information regarding a situation the compiler has encountered or some action the compiler is about to take. The information is being displayed “for your interest”, and typically requires no action to be taken. Compilation will continue as normal after such a message is issued.
<b>Warning Messages</b>	indicate source code or some other situation that can be compiled, but is unusual and can lead to a runtime failure of the code. The code or situation that triggered the warning should be investigated; however, compilation of the current module will continue, as will compilation of any remaining modules.
<b>Error Messages</b>	indicate source code that is illegal or that compilation of this code cannot take place. Compilation will be attempted for the remaining source code in the current module, but no additional modules will be compiled and the compilation process will then conclude.
<b>Fatal Error Messages</b>	indicate a situation in which the compilation cannot proceed and requires that the compilation process to stop immediately.

## 4.6.4 Message Format

By default, messages are printed in a human-readable format. This format can vary from one compiler application to another, since each application reports information about different file formats.

Some applications (for example, the parser) are typically able to pinpoint the area of interest down to a position on a particular line of C source code, whereas other applications, such as the linker, can at best only indicate a module name and record number, which is less directly associated with any particular line of code. Some messages relate to issues in driver options that are in no way associated with any source code.

There are several ways of changing the format in which message are displayed. They are discussed below.

The driver option `-E` (with or without a filename) alters the format of all displayed messages. See [Section 4.8.3 “-E: Redirect Compiler Errors to a File”](#), for details. Using this option produces messages that are better suited to machine parsing, and are less user-friendly. Typically, each message is displayed on a single line. The general form of messages produced when using the `-E` option is:

```
filename line: (message number) message string (type)
```

The `-E` option also has another effect. When used, the driver first checks to see if special environment variables have been set. If so, the format dictated by these variables is used as a template for all messages that will be produced by all compiler applications. The names of these environment variables are given in [Table 4-4](#).

**TABLE 4-4: MESSAGING ENVIRONMENT VARIABLES**

Variable	Effect
HTC_MSG_FORMAT	All advisory messages
HTC_WARN_FORMAT	All warning messages
HTC_ERR_FORMAT	All error and fatal error messages

The value of these environment variables are strings that are used as templates for the message format. Printf-like placeholders can be placed within the string to allow the message format to be customized. The placeholders, and what they represent, are presented in [Table 4-5](#).

**TABLE 4-5: MESSAGING PLACEHOLDERS**

Placeholder	Replacement
%a	Application name
%c	Column number
%f	Filename
%l	Line number
%n	Message number
%s	Message string (from MDF)

If these options are used in a DOS batch file, two percent characters will need to be used to specify the placeholders, as DOS interprets a single percent character as an argument and will not pass this on to the compiler. For example:

```
SET HTC_ERR_FORMAT="file %%f: line %%l"
```

Environment variables, in turn, can be overridden by the driver options: `--MSGFORMAT`, `--WARNFORMAT` and `--ERRFORMAT`, see [Section 4.8.28 “--ERRFORMAT: Define Format for Compiler Messages”](#). These options take a string as their argument. The option strings are formatted, and can use the same placeholders as their variable counterparts.

For example, a project is compiled, but, as shown, produces a warning from the parser and an error from the linker (numbered 362 and 492, respectively).

```
main.c: main()
    17: ip = &b;
           ^ (362) redundant "&" applied to array (warning)
(492) attempt to position absolute psect "text" is illegal
```

Notice that the parser message format identifies the particular line and position of the offending source code.

If the `-E` option is now used and the compiler issues the same messages, the compiler will output:

```
main.c: 12: (362) redundant "&" applied to array (warning)
(492) attempt to position absolute psect "text" is illegal (error)
```

The user now uses the `--WARNFORMAT` in the following fashion:

```
--WARNFORMAT="%a %n %l %f %s"
```

When recompiled, the following output will be displayed:

```
parser 362 12 main.c redundant "&" applied to array
(492) attempt to position absolute psect "text" is illegal (error)
```

Notice that the format of the warning was changed, but that of the error message was not. The warning format now follows the specification of the environment variable. The application name (`parser`) was substituted for the `%a` placeholder, the message number (`362`) substituted the `%n` placeholder, etc.

## 4.6.5 Changing Message Behavior

Both the attributes of individual messages and general settings for the messaging system can be modified during compilation. There are both driver options and C pragmas that can be used to achieve this.

### 4.6.5.1 DISABLING MESSAGES

Each warning message has a default number indicating a level of importance. This number is specified in the MDF and ranges from -9 to 9. The higher the number, the more important the warning.

Warning messages can be disabled by adjusting the warning level threshold using the `--WARN` driver option, see [Section 4.8.65 “--WARN: Set Warning Level”](#). Any warnings whose level is below that of the current threshold are not displayed.

The default threshold is 0 which implies that only warnings with a warning level of 0 or higher will be displayed by default. The information in this option is propagated to all compiler applications, so its effect will be observed during all stages of the compilation process.

Warnings can also be disabled by using the `--MSGDISABLE` option, see [Section 4.8.40 “--MSGDISABLE: Disable Warning Messages”](#). This option takes a *comma*-separated list of warning numbers. The warnings corresponding to the numbers listed are disabled and will never be issued, regardless of the current warning level threshold. If the special message number 0 is specified, then all warning messages are disabled.

Some warning messages can also be disabled by using the `warning` pragma. This pragma will only affect warnings that are produced by either the parser or the code generator; i.e., errors directly associated with C code. See [Section 5.14.4.11 “The #pragma warning Directive”](#) for more information on this pragma.

Error messages can also be disabled; however, a more verbose form of the above command is required to confirm the action. To specify an error message number in the `--MSGDISABLE` command, each error number must be followed by `:off` to ensure that it is disabled. For example:

```
--MSGDISABLE=1257,195:off,194:off
```

will disable warning 1257, and errors 195 and 194.

<p><b>Note:</b> Disabling error or warning messages in no way fixes the condition that triggered the message. Always use extreme caution when exercising these options.</p>
---

#### 4.6.5.2 CHANGING MESSAGE TYPES

It is also possible to change the type of some messages. This can only be done for messages generated by the parser or code generator. See [Section 5.14.4.11 “The #pragma warning Directive”](#), for more information on this pragma.

## 4.7 MPLAB XC8 DRIVER OPTIONS

This section looks at the general form of `xc8` command-line options and what action the compiler will perform if no option is specified for a certain feature.

### 4.7.1 General Option Formats

All single letter options are identified by a leading *dash* character, “-”, for example: `-C`. Some single letter options specify an additional data field that follows the option name immediately and without any *whitespace*, for example: `-Ddebug`. In this manual, options are written in upper case and suboptions are written in lower case.

Multi-letter, or word, options have two leading *dash* characters, for example:

`--ASMLIST`. (Because of the double *dash*, the driver can determine that the option `--DOUBLE`, for example, is not a `-D` option followed by the argument `DOUBLE`.)

Some of these word options use suboptions which typically appear as a *comma*-separated list following an *equal* character, `=`, for example: `--OUTPUT=hex,cof`. The exact formats of the options vary. The options and formats are described in detail in the following sections.

Some commonly used suboptions include `default`, which represent the default specification that would be used if this option was absent altogether; `all`, which indicates that all the available suboptions should be enabled as if they had each been listed; and `none`, which indicates that all suboptions should be disabled. For example:

```
--OPT=none
```

will turn off all optimizers.

Some suboptions can be prefixed with a plus character, `+`, to indicate that they are in addition to the other suboptions present; or a minus character “-”, to indicate that they should be excluded. For example:

```
--OPT=default,-asm
```

indicates that the default optimization be used, but that the assembler optimizer should be disabled. If the first character after the equal sign is `+` or `-`, then the default keyword is implied. For example:

```
--OPT=-asm
```

is the same as the previous example.

See the `--HELP` option, [Section 4.8.34 “--HELP: Display Help”](#), for more information about options and suboptions.

### 4.7.2 Default Options

If you run the compiler driver from the command line and do not specify the option for a feature, it will default to a certain state. You can also specify the `default` suboption (to double-dash options) that will also invoke the default behavior. You can check what the default behavior is by using the `--HELP=option` on the command line, see [Section 4.8.34 “--HELP: Display Help”](#).

If you are compiling from within the MPLAB X IDE, it will, by default, issue explicit options to the compiler (unless changed in the Project Properties dialog), and these options can be different to those that are the default on the command line. For example, unless you specify the `--ASMLIST` option on the command line, the default operation of the compiler is *not* to produce an assembly list file. But, if you are compiling from within the MPLAB X IDE, the default operation (this, in fact, cannot be disabled) is to *always* produce an assembly list file.

If you are compiling the same project from the command line and from the MPLAB X IDE, always check that all options are explicitly specified.

## 4.8 OPTION DESCRIPTIONS

Most aspects of the compilation can be controlled using the command-line driver, `xc8`. The driver will configure and execute all required applications, such as the code generator, assembler and linker.

`xc8` recognizes the compiler options which are tabled below and are explained in detail in the sections following. The case of the options is not important; however, command shells in most operating systems are case sensitive when it comes to the names of files.

**TABLE 4-6: DRIVER OPTIONS**

Option	Meaning
<code>-C</code>	Compile to object file and stop
<code>-Dmacro</code>	Define preprocessor macro symbol
<code>-Efilename</code>	Redirect compile errors
<code>-G[filename]</code>	Generate symbolic debug information
<code>-Ipath</code>	Specify include path
<code>-Largument</code>	Set linker option
<code>-M[filename]</code>	Generate map file
<code>-Nnumber</code>	Specify identifier length
<code>-Ofile</code>	Specify output filename and type
<code>-P</code>	Preprocess assembly source
<code>-Q</code>	Quiet mode
<code>-S</code>	Compile to assembly file and stop
<code>-Umacro</code>	Undefine preprocessor macro symbol
<code>-V</code>	Verbose mode
<code>--ADDRQUAL=qualifier</code>	Specify address space qualifier handling
<code>--ASMLIST</code>	Generate assembly list file
<code>--CHAR=type</code>	Default character type (defunct)
<code>--CHECKSUM=specification</code>	Calculate a checksum or CRC and store the result in program memory
<code>--CHIP=device</code>	Select target device
<code>--CHIPINFO</code>	Print device information
<code>--CODEOFFSET=value</code>	Specify ROM offset address
<code>--DEBUGGER=type</code>	Set debugger environment
<code>--DEP=specifications</code>	Generate dependency file
<code>--DOUBLE=size</code>	Size of double type
<code>--ECHO</code>	Echo command line
<code>--EMI=mode</code>	Select external memory interface operating mode
<code>--ERRATA=type</code>	Specify errata workarounds
<code>--ERRFORMAT=format</code>	Set error format
<code>--ERRORS=number</code>	Set maximum number of errors
<code>--EXT=extensions</code>	Specify C language extensions
<code>--FILL=specification</code>	Specify a ROM-fill value for unused memory
<code>--FLOAT=size</code>	Size of float type
<code>--GETOPTION=argument</code>	Get advanced options
<code>--HELP=option</code>	Help
<code>--HTML=file</code>	Generate HTML debug files
<code>--LANG=language</code>	Specify language



**TABLE 4-6: DRIVER OPTIONS (CONTINUED)**

Option	Meaning
--MAXIPIC	Maximize current device's memory resources
--MEMMAP= <i>mapfile</i>	Display memory map
--MODE= <i>mode</i>	Choose operating mode
--MSGDISABLE= <i>list</i>	Disable warning messages
--MSGFORMAT= <i>specification</i>	Set advisory message format
--NODEL	Do not remove temporary files
--NOFALLBACK	Error if the request operating mode cannot be used
--OBJDIR= <i>path</i>	Set object files directory
--OPT= <i>optimizations</i>	Control optimization
--OUTDIR= <i>path</i>	Set output directory
--OUTPUT= <i>path</i>	Set output formats
--PARSER= <i>mode</i>	Specify parser mode
--PASS1	Produce intermediate p-code file and stop
--PRE	Produce preprocessed source files and stop
--PROTO	Generate function prototypes
--RAM= <i>ranges</i>	Adjust RAM ranges
--ROM= <i>ranges</i>	Adjust ROM ranges
--RUNTIME= <i>options</i>	Specify runtime options
--SCANDEP	Scan for dependencies
--SERIAL= <i>specification</i>	Insert a hexadecimal code or serial number
--SETOPTION= <i>argument</i>	Set advanced options
--SETUP= <i>specification</i>	Setup the compiler
--SHROUD	Shroud (obfuscate) generated p-code files
--STACK= <i>type[:sizes]</i>	Specify data stack type and sizes
--STRICT	Use strict ANSI keywords
--SUMMARY= <i>type</i>	Summary options
--TIME	Report compilation times
--UNDEFINTS= <i>action</i>	Program unused interrupt vectors
--VER	Show version information
--WARN= <i>number</i>	Set warning threshold level
--WARNFORMAT= <i>specification</i>	Set warning format

## 4.8.1 -C: Compile to Object File

The `-C` option is used to halt compilation after executing the assembler, leaving a relocatable object file as the output. It is frequently used when compiling assembly source files using a make utility. It cannot be used unless all C source files are present on the command line. Use `--PASS1` to generate intermediate files from C source, see [Section 4.8.49 "--PASS1: Compile to P-code"](#).

See [Section 4.3.3 "Multi-Step Compilation"](#), for more information on generating and using intermediate files.

## 4.8.2 -D: Define Macro

The `-D` option is used to define a preprocessor macro on the command line, exactly as if it had been defined using a `#define` directive in the source code. This option can take one of two forms, `-Dmacro` which is equivalent to:

```
#define macro 1
```

placed at the top of each module compiled using this option, or `-Dmacro= text` which is equivalent to:

```
#define macro text
```

where *text* is the textual substitution required. Thus, the command:

```
xc8 --CHIP=16F877AA -Ddebug -Dbuffers=10 test.c
```

will compile `test.c` with macros defined exactly as if the C source code had included the directives:

```
#define debug 1
#define buffers 10
```

Defining macros as C string literals requires bypassing any interpretation issues in the operating system that is being used. To pass the C string, "hello world", (including the *quote* characters) in the Windows environment, use: `"-DMY_STRING=\\\\"hello world\\\\""` (you must include the *quote* characters around the entire option, as there is a *space* character in the macro definition). Under Linux or Mac OS X, use:

```
-DMY_STRING=\"hello\ world\".
```

See [Section 4.9 "MPLAB X Option Equivalents"](#), for use of this option in MPLAB X IDE.

## 4.8.3 -E: Redirect Compiler Errors to a File

This option has two purposes. The first is to change the format of displayed messages. The second is to optionally allow messages to be directed to a file, as some editors do not allow the standard command line redirection facilities to be used when invoking the compiler.

The general form of messages produced with the `-E` option in force is:

```
filename line_number: (message number) message string (type)
```

If a filename is specified immediately after `-E`, it is treated as the name of a file to which all messages (errors, warnings, etc.) will be printed. For example, to compile `x.c` and redirect all errors to `x.err`, use the command:

```
xc8 --CHIP=16F877AA -Ex.err x.c
```

The `-E` option also allows errors to be appended to an existing file by specifying an addition character, `+`, at the start of the error filename, for example:

```
xc8 --CHIP=16F877AA -E+x.err y.c
```

If you wish to compile several files and combine all of the errors generated into a single text file, use the `-E` option to create the file then use `-E+` when compiling all the other source files. For example, to compile a number of files with all errors combined into a file called `project.err`, you could use the `-E` option as follows:

```
xc8 --CHIP=16F877AA -Eproject.err -O --PASS1 main.c
xc8 --CHIP=16F877AA -E+project.err -O --PASS1 part1.c
xc8 --CHIP=16F877AA -E+project.err -C asmcode.as
```

[Section 4.6 "Compiler Messages"](#) has more information regarding this option as well as an overview of the messaging system and other related driver options.

## 4.8.4 -I: Include Search Path

Use `-I` to specify an additional directory to search for header files which have been included using the `#include` directive. The directory can either be an absolute or relative path. The `-I` option can be used more than once if multiple directories are to be searched.

The compiler's `include` directory containing all standard header files is always searched, even if no `-I` option is present. If header filenames are specified using *quote* characters rather than *angle brackets*, as in `#include "lcd.h"`, then the current working directory is searched in addition to the compiler's `include` directory. Note that if compiling within MPLAB X IDE, the search path is relative to the output directory, not the project directory.

These default search paths are searched after any user-specified directories have been searched. For example, the following code:

```
xc8 --CHIP=16F877AA -C -Ic:\include -Id:\myapp\include test.c
```

will search the directories `c:\include` and `d:\myapp\include` for any header files included into the source code, then search the default include directory.

Under Windows OS, be aware that use of the directory backslash character may unintentionally form an escape sequence. For example, to specify an include file path that ends with a directory separator character and which is quoted, use `-I"E:\\" instead of -I"E:\", to avoid the escape sequence \". Note that MPLAB X IDE will quote any include file path you specify in the project properties.`

This option has no effect for files that are included into assembly source using the assembly `INCLUDE` directive. See [Section 6.2.10.5 "INCLUDE"](#), for details.

See [Section 4.9 "MPLAB X Option Equivalents"](#), for use of this option in MPLAB X IDE.

## 4.8.5 -L: Scan Library

The `-L` option is used to specify additional libraries that are to be scanned by the linker. Libraries specified using the `-L` option are scanned before the standard C library, allowing additional versions of standard library functions to be accessed.

The argument to `-L` is a library keyword to which the prefix `pic`; numbers representing the device range, number of ROM pages and the number of RAM banks; and the suffix `.lib` are added.

In this way, the option `-L1`, when compiling for a 16F877A, will, for example, scan the library `pic42c-1.lib` and the option `-Lxx` will scan a library called `pic42c-xx.lib`.

All libraries must be located in the `lib` directory of the compiler installation directory.

As indicated, the argument to the `-L` option is *not* a complete library filename. If you wish the linker to scan libraries whose names do not follow the naming convention previously mentioned or whose locations are not in the `lib` subdirectory, simply include the libraries' names on the command line along with your source files, or add these to your project.

## 4.8.6 -L: Adjust Linker Options Directly

The `-L` driver option can be used to specify an option that will be passed directly to the linker. If `-L` is followed immediately by text starting with a dash character “-”, the text will be passed directly to the linker without being interpreted by the `xc8` command-line driver. When not followed immediately by a dash character, the `-L` option is assumed to be the library scan option; see [Section 4.8.5 “-L: Scan Library”](#) for more information.

For example, if the option `-L-N` is specified, the `-N` option will be passed on to the linker without any subsequent interpretation by the driver.

Take care with command-line options. The linker cannot interpret command-line driver options; similarly, the driver cannot interpret linker options. In most situations, it is always the command-line driver, `xc8`, that is being executed. You are always invoking the driver if you build from MPLAB X IDE.

If you are building from MPLAB X IDE, add any `-L-` driver options to the Extra linker options field in the Additional options category of the Linker category in the Project Properties dialog, see [Section 4.9.3.4 “Additional”](#).

The `-L` option is especially useful when linking code that contains non-standard program sections (or psects), as can be the case if the program contains hand-written assembly code that contains user-defined psects (see [6.2.9.3 PSECT](#), and [Section 5.15.1 “Program Sections”](#)), or C code which uses the `__section()` specifier (see [Section 5.15.4 “Changing and Linking the Allocated Section”](#)).

This option can also be used to replace default linker options. The default linker option for a psect is removed if that psect's name is specified in a `-L-` option. Any psects listed after that psect's name in the default options are also removed. For example, if a default linker option was:

```
-preset_vec=00h,intentry,init,end_init
```

using the driver option `-L-pinit=100h` would result in the following options being passed to the linker:

```
-pinit=100h -preset_vec=00h,intentry.
```

Note that the `end_init` linker option has been removed entirely.

If there are no characters following the first equal character in the `-L` option, then no replacement will be made for the default linker options that will be deleted. For example, the driver option `-L-pinit=` was instead issued in the previous example, the following option would be passed to the linker: `-preset_vec=00h,intentry`.

No warning is generated if such a default linker option cannot be found. The default option that you are deleting or replacing must contain an equal character.

## 4.8.7 -M: Generate Map File

The `-M` option is used to request the generation of a map file. The map file is generated by the linker and includes detailed information about where objects are located in memory. See [Section 7.4 “Map Files”](#) for information regarding the content of these files.

If no filename is specified with the option, then the name of the map file will have the project name (see [Section 4.3 “The Compilation Sequence”](#)), with the extension `.map`.

This option is on by default when compiling from within MPLAB X IDE and using the Universal Toolsuite.

## 4.8.8 -N: Identifier Length

This option allows the significant C identifier length (used by functions and variables) to be decreased from the default value of 255. Valid sizes for this option are from 31 to 255. The option has no effect for all other values.

This option also controls the significant length of identifiers used by the preprocessor, such as macro names. The default length is also 255, and can be adjusted to a minimum of 31.

If the `--STRICT` option is used, the default significant identifier length is reduced to 31. Code that uses a longer identifier length will be less portable.

See [Section 4.9 “MPLAB X Option Equivalents”](#), for use of this option in MPLAB X IDE.

## 4.8.9 -O: Specify Output File

This option allows the base name of the output file(s) to be specified. If no `-O` option is given, the base name of output file(s) will be the same as the project name, see [Section 4.3 “The Compilation Sequence”](#). The files whose names are affected by this option are those files that are not directly associated with any particular source file, such as the HEX file, MAP file and SYM file.

The `-O` option can also change the directory in which the output file is located by including the required path before the filename. This will then also specify the output directory for any files produced by the linker or subsequently run applications. Any relative paths specified are with respect to the current working directory.

For example, if the option `-Oc:\project\output\first` is used, the MAP and HEX file, etc., will use the base name `first`, and will be placed in the directory `c:\project\output`.

Any extension supplied with the filename will be ignored.

If a path is specified with the option that enables MAP file creation, `-M`, (see [Section 4.8.7 “-M: Generate Map File”](#)), this overrides any name or path information provided by `-O`.

To change the directory in which all output and intermediate files are written, use the `--OUTDIR` option; see [Section 4.8.46 “--OUTDIR: Specify a Directory for Output Files”](#). Note that if `-O` specifies a path that is inconsistent with the path specified in the `--OUTDIR` option, it will result in an error.

## 4.8.10 -P: Preprocess Assembly Files

The `-P` option causes assembler source files to be preprocessed before they are assembled, thus allowing the use of preprocessor directives, such as `#include`, and C-style comments with assembler code.

By default, assembler files are not preprocessed.

See [Section 4.9 “MPLAB X Option Equivalents”](#), for use of this option in MPLAB X IDE.

## 4.8.11 -Q: Quiet Mode

This option places the compiler in a quiet mode that suppresses the Microchip Technology Incorporated copyright notice from being displayed.

## 4.8.12 -S: Compile to Assembler Code

The `-S` option stops compilation after generating an assembly output file. One assembly file will be generated for all the C source code, including p-code library code.

The command:

```
xc8 --CHIP=16F877A -S test.c
```

will produce an assembly file called `test.as`, which contains the assembly code generated from `test.c`. The generated file is valid assembly code that could be passed to `xc8` as a source file, however this should only be done for exploratory reasons. To take advantage of the benefits of the compilation technology in the compiler, it must compile and link all the C source code in a single step. See the `--PASS1` option (Section 4.8.49 “`--PASS1: Compile to P-code`”) to generate intermediate files if you wish to compile code using a two-step process or use intermediate files.

This option is useful for checking assembly code output by the compiler. The file produced by this option differs to that produced by the `--ASMLIST` option (see Section 4.8.15 “`--ADDRQUAL: Set Compiler Response to Memory Qualifiers`”) in that it does not contain op-codes or addresses and it can be used as a source file in subsequent compilations. The assembly list file is more human readable, but is not a valid assembly source file.

## 4.8.13 -U: Undefine a Macro

The `-U` option, the inverse of the `-D` option, is used to undefine predefined macros. This option takes the form `-Umacro`, where `macro` is the name of the macro to be undefined.

The option, `-Udraft`, for example, is equivalent to:

```
#undef draft
```

placed at the top of each module compiled using this option.

See Section 4.9 “MPLAB X Option Equivalents”, for use of this option in MPLAB X IDE.

## 4.8.14 -V: Verbose Compile

The `-V` option specifies verbose compilation. When used, the compiler will display the command lines used to invoke each of the compiler applications described in Section 4.3 “The Compilation Sequence”.

When this option is used, the name and path of the compiler application being executed will be displayed, followed by the name of the command file that holds the command-line arguments to this application, for example:

```
/Applications/dev/XC8/v1.35/bin/hexmate @/tmp/hexmated_xcLN1sWk6.cmd
```

If this option is used twice (`-V -V`), the display will additionally show the contents of the command file in square brackets, for example.

```
/Applications/dev/XC8/v1.35/bin/hexmate @/tmp/hexmated_xcLN1sWk6.cmd [
--edf=/Applications/dev/XC8/v1.35/dat/en_msgs.txt main.hex -Omain.hex
-logfile=main.hxl -addressing=1 -break=300000 ]
```

See Section 4.9 “MPLAB X Option Equivalents”, for use of this option in MPLAB X IDE.

## 4.8.15 --ADDRQUAL: Set Compiler Response to Memory Qualifiers

The `--ADDRQUAL` option indicates the compiler's response to non-standard memory qualifiers in C source code.

By default, these qualifiers are ignored; i.e., they are accepted without error, but have no effect. Using this option allows these qualifiers to be interpreted differently by the compiler.

The `near` qualifier is affected by this option. On PIC18 devices, this option also affects the `far` qualifier; and for other 8-bit devices, the `bankx` qualifiers (`bank0`, `bank1`, `bank2`, etc.) are affected.

The suboptions are detailed in [Table 4-7](#).

**TABLE 4-7: COMPILER RESPONSES TO MEMORY QUALIFIERS**

Selection	Response
<code>require</code>	The qualifiers will be honored. If they cannot be met, an error will be issued.
<code>request</code>	The qualifiers will be honored, if possible. No error will be generated if they cannot be followed.
<code>ignore</code>	The qualifiers will be ignored and code compiled as if they were not used.
<code>reject</code>	If the qualifiers are encountered, an error will be immediately generated.

For example, when using the option `--ADDRQUAL=request` the compiler will try to honor any non-standard qualifiers, but silently ignore them if they cannot be met.

See [Section 4.9 "MPLAB X Option Equivalents"](#), for use of this option in MPLAB X IDE.

## 4.8.16 --ASMLIST: Generate Assembler List Files

The `--ASMLIST` option tells `xc8` to generate *assembler listing files* for the C and assembly source modules being compiled. One assembly list file is produced for the entire C program, including code from the C library functions.

Additionally, one assembly list file is produced for each assembly source file in the project, including the runtime startup code. For more information, see [Section 4.4.2 "Startup and Initialization"](#).

Assembly list files use a `.lst` extension and, due to the additional information placed in these files, cannot be used as assembly source files.

In the case of listings for C source code, the list file shows both the original C code and the corresponding assembly code generated by the compiler. See [Section 6.3 "Assembly-Level Optimizations"](#), for full information regarding the content of these files.

The same information is shown in the list files for assembly source code.

This option is on by default when compiling under MPLAB X IDE.



## 4.8.17 --CHECKSUM: Calculate a Checksum

This option will calculate a hash value (for example checksum or CRC) over the address range specified and store the result at the destination address specified. The general form of this option is as follows.

```
--CHECKSUM=start-end@destination[, specifications]
```

Additional specifications are appended as a *comma*-separated list to this option. Such specifications are:

<b>width=<i>n</i></b>	selects the width of the hash result in bytes for non-Fletcher algorithms. A negative width will store the result in little-endian byte order; positive widths in big-endian order. Result widths from one to four bytes are permitted.
<b>offset=<i>nnnn</i></b>	specifies an initial value or offset to be added to this checksum.
<b>algorithm=<i>n</i></b>	selects one of the hash algorithms implemented in HEXMATE. The selectable algorithms are described in <a href="#">Table 8-4</a> .
<b>polynomial=<i>nnnn</i></b>	selects the polynomial value when using CRC algorithms
<b>code=<i>nn</i></b>	is a hexadecimal code that will trail each byte in the result. This can allow each byte of the result to be embedded within an instruction, for example <code>code=34</code> will embed the result in a RETLW instruction on mid-range devices.

The *start*, *end* and *destination* attributes are, by default, hexadecimal constants. If an accompanying --FILL option has not been specified, unused locations within the specified address range will be automatically filled with 0xFFF for baseline devices, 0x3FFF for mid-range devices, or 0xFFFF for PIC18 devices. This is to remove any unknown values from the equation and ensure the accuracy of the result.

For example:

```
--checksum=800-fff@20,width=1,algorithm=2
```

will calculate a 1-byte checksum from address 0x800 to 0xff and store this at address 0x20. A 16-bit addition algorithm will be used. See [Table 4-8](#), for the available algorithms and [Section 8.4 "Hash Functions"](#) for more information on calculating checksum and hash values.

**TABLE 4-8: CHECKSUM ALGORITHM SELECTION**

Selector	Algorithm description
-5	Reflected cyclic redundancy check (CRC)
-4	Subtraction of 32 bit values from initial value
-3	Subtraction of 24 bit values from initial value
-2	Subtraction of 16 bit values from initial value
-1	Subtraction of 8 bit values from initial value
1	Addition of 8 bit values from initial value
2	Addition of 16 bit values from initial value
3	Addition of 24 bit values from initial value
4	Addition of 32 bit values from initial value
5	Cyclic redundancy check (CRC)
7	Fletcher's checksum (8 bit calculation, 2-byte result width)
8	Fletcher's checksum (16 bit calculation, 4-byte result width)

The hash calculations are performed by the HEXMATE application. The information in this driver option is passed to the HEXMATE application when it is executed.



## 4.8.18 --CHIP: Define Device

This option must be used to specify the target device, or device, for the compilation. This is the only compiler option that is mandatory when compiling code.

To see a list of supported devices that can be used with this option, use the `--CHIPINFO` option described in the next section in this guide.

## 4.8.19 --CHIPINFO: Display List of Supported Devices

The `--CHIPINFO` option displays a list of devices the compiler supports. The names listed are those chips that are defined in the `chipinfo` file and which can be used with the `--CHIP` option.

Compiler execution will terminate after this list has been printed.

## 4.8.20 --CLIST: Generate C Listing File

Use of this option will generate a C listing file for each C source file specified on the command line.

The listing files produced consist of the original C source code prepended with a line number. Do not confuse these files with assembly list files, see [Section 4.8.16 "--ASMLIST: Generate Assembler List Files"](#).

## 4.8.21 --CODEOFFSET: Offset Program Code to Address

In some circumstances, such as bootloaders, it is necessary to shift the program image to an alternative address. This option is used to specify a base address for the program code image and to reserve memory from address 0 to that specified in the option.

When using this option, all code psects (including Reset and interrupt vectors and constant data) will be adjusted to the address specified. The address is assumed to be a hexadecimal constant. A leading `0x`, or a trailing `h` hexadecimal specifier can be used, but is not necessary.

This option differs from the `--ROM` option in that it will move the code associated with the Reset and interrupt vectors. That cannot be done using the `--ROM` option, see [Section 4.8.53 "--ROM: Adjust ROM Ranges"](#).

For example, if the option `--CODEOFFSET=600` is specified, the Reset vector will be moved from address 0 to address 0x600; the interrupt vector will be moved from address 4 to 0x604, in the case of mid-range PIC devices, or to the addresses 0x608 and 0x618 for PIC18 devices. No code will be placed between address 0 and 0x600.

As the Reset and interrupt vector locations are fixed by the PIC device, it is the programmer's responsibility to ensure code that can redirect control to the offset Reset and interrupt routines is written and located at the original locations.

See [Section 4.9 "MPLAB X Option Equivalents"](#), for use of this option in MPLAB X IDE.

## 4.8.22 --DEBUGGER: Select Debugger Type

This option is intended for use for compatibility with development tools that can act as a debugger. `xc8` supports several debuggers and using this option will configure the compiler to conform to the requirements of that selected. The possible selections for this option are defined in [Table 4-9](#).

**TABLE 4-9: SELECTABLE DEBUGGERS**

Suboption	Debugger selected
<code>none</code>	No debugger (default)
<code>icd2</code>	MPLAB® ICD 2
<code>icd3</code>	MPLAB ICD 3
<code>pickit2</code>	PICKit™ 2
<code>pickit3</code>	PICKit 3
<code>realice</code>	MPLAB REAL ICE™ in-circuit emulator

For example:

```
xc8 --CHIP=16F877AA --DEBUGGER=icd2 main.c
```

Choosing the correct debugger is important as they can use memory resources that could otherwise be used by the project if this option is omitted. Such a conflict would lead to runtime failure.

If the debugging features of the development tool are not to be used (for example, if the MPLAB ICD 3 is only being used as a programmer), then the debugger option can be set to `none`, because memory resources are not being used by the tool.

MPLAB X IDE will automatically apply this option for debug builds once you have indicated the hardware tool in the Project Preferences.

## 4.8.23 --DEP: Generate dependency file

This option controls the generation of dependency files. A dependency file lists those files on which a source file's content is dependent. Dependencies result when one file is `#included` into another. [Table 4-10](#) shows the suboptions which are allowed with this option. See also [Section 4.8.55 "--SCANDEP: Scan for Dependencies"](#).

**TABLE 4-10: SELECTABLE DEPENDENCY OPTIONS**

Suboption	Dependency style
<code>stop</code>	Stop compilation after file generation
<code>list</code>	Format dependency file as a list ( <code>.dep</code> file)
<code>gcc</code>	Create a GCC-style dependency file ( <code>.d</code> file)
<code>sys</code>	Include system headers in dependency file

## 4.8.24 --DOUBLE: Select Kind of Double Types

This option allows the kind of double-precision floating-point types to be selected. By default, the compiler will choose the truncated IEEE754 24-bit format for `double` types. With this option, it can be changed to the full 32-bit IEEE754 format. See also [Section 4.8.32 "--FLOAT: Select Kind of Float Types"](#) for specification of the `float` type format.

See [Section 4.9 "MPLAB X Option Equivalents"](#), for use of this option in MPLAB X IDE.

## 4.8.25 --ECHO: Echo Command Line Before Processing

Use of this option will result in the driver command line being echoed to the `stdout` stream before compilation commences. Each token of the command line will be printed on a separate line and they will appear in the order in which they are placed on the command line.

## 4.8.26 --EMI: Select External Memory Interface Operating Mode

The external memory interface available on some PIC18 devices can be operated in several modes. The interface can operate in 16-bit modes; Word-write and Byte-select modes or in an 8-bit mode: Byte-write mode. These modes are represented by those specified in [Table 4-11](#).

**TABLE 4-11: EXTERNAL MEMORY INTERFACE MODES**

Mode	Operation
<code>wordwrite</code>	16-bit Word-write mode (default)
<code>byteselect</code>	16-bit Byte-select mode
<code>bytewrite</code>	8-bit Byte-write mode

The selected mode will affect the code generated when writing to the external data interface. In word write mode, dummy reads and writes can be added to ensure that an even number of bytes are always written. In Byte-select or Byte-write modes, dummy reads and writes are not generated and can result in more efficient code.

Note that this option does not pre-configure the device for operation in the selected mode. See your device data sheet for the registers and settings that are used to configure the device's external interface mode.

See [Section 4.9 "MPLAB X Option Equivalents"](#), for use of this option in MPLAB X IDE.

## 4.8.27 --ERRATA: Specify Errata Workarounds

This option allows specification of software workarounds to documented silicon errata issues. A default set of errata issues apply to each device, but this set can be adjusted by using this option and the arguments presented in [Table 4-12](#).

**TABLE 4-12: ERRATA WORKAROUNDS**

Symbol	Bit pos.	Workaround
4000	0	Program memory accesses/jumps across 4000h address boundary
fastints	1	Fast interrupt shadow registers corruption
lfsr	2	Broken LFSR instruction
minus40	3	Program memory reads at -40 degrees
reset	4	GOTO instruction cannot exist at Reset vector
bsr15	5	Flag problems when BSR holds value 15
daw	6	Broken DAW instruction
eedatard	7	Read EEDAT in immediate instruction after RD set
eeadr	8	Don't set RD bit immediately after loading EEADR
ee_lvd	9	LVD must stabilize before writing EEPROM
fl_lvd	10	LVD must stabilize before writing Flash
tblwtint	11	Clear interrupt registers before tblwt instruction
fw4000	12	Flash write exe must act on opposite side of 4000h boundary
resetram	13	RAM contents can corrupt if async. Reset occurs during write access
fetch	14	Corruptible instruction fetch. – apply FFFFh (NOP) at required locations
clocksw	15	Code corruption if switching to external oscillator clock source – apply switch to HFINTOSC high-power mode first
branch	16	The PC might become invalid when restoring from an interrupt during a BRA or BRW instruction — avoid branch instructions
brknop2	17	Hardware breakpoints might be affected by BRA instruction — avoid branching to the following location
nvmreg	18	The program will access data flash rather than program flash memory after a reset — adjust the NVMCON register

At present, workarounds are mainly employed for PIC18 devices, but the `clocksw` and `branch` errata are only applicable for some enhanced mid-range devices.

To disable all software workarounds, use the following.

```
--ERRATA=none
```

For example, to apply the default set of workarounds, but also to specifically disable the jump across 4000 errata, use the following:

```
--ERRATA=default,-4000
```

A preprocessor macro `_ERRATA_TYPES` (see [Section 5.14.3 “Predefined Macros”](#)) is set to a value to indicate the errata applied. Each errata listed in [Table 4-12](#) represents a bit position in the macro's value, with the topmost errata in the table being the least significant. The bit position is indicated in the table and is set if the corresponding errata is applied. The header file `<errata.h>` contains definitions for each errata value, for example `ERRATA_4000` and `ERRATA_FETCH`, which can be compared with the compiler-defined `_ERRATA_TYPES` macro.

See [Section 4.9 “MPLAB X Option Equivalents”](#), for use of this option in MPLAB X IDE.

## 4.8.28 --ERRFORMAT: Define Format for Compiler Messages

If the `--ERRFORMAT` option is not used, the default behavior of the compiler is to display any errors in a “human readable” form. This standard format is perfectly acceptable to a person reading the error output, but is not generally usable with environments that support compiler error handling.

This option allows the exact format of printed error messages to be specified using special placeholders embedded within a message template. See [Section 4.6 “Compiler Messages”](#) for full details of the messaging system employed by `xc8`, and the placeholders which can be used with this option.

This section is also applicable to the `--WARNFORMAT` and `--MSGFORMAT` options, which adjust the format of warning and advisory messages, respectively.

If you are compiling using MPLAB X IDE, the format of the compiler messages is automatically configured to what the IDE expects. It is recommended that you do not adjust the message formats if compiling using this IDE.

## 4.8.29 --ERRORS: Maximum Number of Errors

This option sets the maximum number of errors each compiler application, as well as the driver, will display before execution is terminated. By default, up to 20 error messages will be displayed by each application.

See [Section 4.6 “Compiler Messages”](#) for full details of the messaging system employed by `xc8`.

## 4.8.30 --EXT: Specify C Language Extensions

The compiler can accept several different sets of non-standard C language extensions. The suboption to `--EXT` indicates the set and these are shown in [Table 4-13](#).

**TABLE 4-13: ACCEPTABLE C LANGUAGE EXTENSIONS**

Suboption	Meaning
<code>xc8</code>	The native XC8 extensions (default)
<code>cci</code>	A common C interface acceptable by all MPLAB XC compilers
<code>iar</code>	Extensions defined by the IAR C/C++ Compiler for ARM

Enabling the `cci` suboption requests the compiler to check all source code and compiler options for compliance with the Common C Interface (CCI). Code that complies with this interface is portable across all MPLAB XC compilers. Code or options that do not conform to the CCI will be flagged by compiler warnings. See [Chapter 2. Common C Interface](#), for information on the features that are covered by this interface.

The `iar` suboption enables conformance with the non-standard extensions supported by the IAR C/C++ Compiler™ for ARM. This is discussed further in [Appendix B. Embedded Compiler Compatibility Mode](#).

## 4.8.31 --FILL: Fill Unused Program Memory

This option allows specification of a hexadecimal opcode that can be used to fill all unused program memory locations. This option utilizes the features of the `HEXMATE` application, so it is only available when producing a HEX output file, which is the default operation.

This driver feature allows you to compile and fill unused locations in one step. If you prefer not to use the driver option and you prefer to fill unused locations after compilation, then you need to use the `HEXMATE` application. Note that the corresponding option in `HEXMATE` is `-FILL` (one leading dash) as opposed to the driver's `--FILL` option. Note, also, that the `unused` tag that can be specified with the driver option does not exist in the `HEXMATE` options.

The usage of the driver option is:

```
--FILL=[const_width:]fill_expr[@address[:end_address]]
```

where:

- *const\_width* has the form *wn* and signifies the width (*n* bytes) of each constant in *fill\_expr*. If *const\_width* is not specified, the default value is the native width of the architecture. That is, `--FILL=w1:1` will fill every byte with the value `0x01`.
- *fill\_expr* can use the syntax (where *const* and *increment* are *n*-byte constants):
  - *const* fill memory with a repeating constant; i.e., `--FILL=0xBEEF` becomes `0xBEEF, 0xBEEF, 0xBEEF, 0xBEEF`
  - *const+increment* fill memory with an incrementing constant; i.e., `--fill=0xBEEF+=1` becomes `0xBEEF, 0xBEF0, 0xBEF1, 0xBEF2`
  - *const-increment* fill memory with a decrementing constant; i.e., `--fill=0xBEEF-=0x10` becomes `0xBEEF, 0xBEDF, 0xBECF, 0xBEBF`
  - *const, const, ..., const* fill memory with a list of repeating constants; i.e., `--FILL=0xDEAD, 0xBEEF` becomes `0xDEAD, 0xBEEF, 0xDEAD, 0xBEEF`
- The options following *fill\_expr* result in the following behavior:
  - `@unused` (or nothing) fill all unused memory with *fill\_expr*; i.e., `--FILL=0xBEEF@unused` fills all unused memory with `0xBEEF`. The driver will expand this to the appropriate ranges and pass these to `HEXMATE`.
  - `@address` fill a specific address with *fill\_expr*; i.e., `--FILL=0xBEEF@0x1000` puts `0xBEEF` at address `1000h`
  - `@address:end_address` fill a range of memory with *fill\_expr*; i.e., `--FILL=0xBEEF@0:0xFF` puts `0xBEEF` in unused addresses between `0` and `255`

All constants can be expressed in (unsigned) binary, octal, decimal or hexadecimal, as per normal C syntax. For example, `1234` is a decimal value, `0xFF00` is hexadecimal, and `FF00` is illegal.

See [Section 4.9 "MPLAB X Option Equivalents"](#), or [Section 4.9 "MPLAB X Option Equivalents"](#), for information on using this option in MPLAB X IDE.

## 4.8.32 --FLOAT: Select Kind of Float Types

This option allows the size of `float` types to be selected. The types available to be selected are given in [Table 4-14](#).

See also, the `--DOUBLE` option in [Section 4.8.24 “--DOUBLE: Select Kind of Double Types”](#).

**TABLE 4-14: FLOATING-POINT SELECTIONS**

Suboption	Effect
<code>double</code>	Size of float matches size of <code>double</code> type
<code>24</code>	24-bit float (default)
<code>32</code>	32-bit float (IEEE754 format)

See [Section 4.9 “MPLAB X Option Equivalents”](#), for use of this option in MPLAB X IDE.

## 4.8.33 --GETOPTION: Get Command-line Options

This option is used to retrieve the command line options that are used for named compiler application. The options are then saved into the given file. This option is not required for most projects, and is disabled when the compiler is operating in Free mode (see [Section 4.8.39 “--MODE: Choose Compiler Operating Mode”](#)).

The options take an application name and a filename to store the options, for example:

```
--GETOPTION=hlink,options.txt
```

## 4.8.34 --HELP: Display Help

This option displays information on the `xc8` compiler options. The option `--HELP` will display all options available. To find out more about a particular option, use the option's name as a parameter. For example:

```
xc8 --help=warn
```

will display more detailed information about the `--WARN` option, the available suboptions, and which suboptions are enabled by default.

## 4.8.35 --HTML: Generate HTML Diagnostic Files

This option will generate a series of HTML files that can be used to explore the compilation results of the latest build. The files are stored in a directory called `html`, located in the output directory. The top-level file (which can be opened with your favorite web browser) is called `index.html`.

Use this option at all stages of compilation to ensure files associated with all compilation stages are generated.

The index page is a graphical representation of the compilation process. Each file icon is clickable and will open to show the contents of that file. This is available for all intermediate files, and even binary files will open in a human-readable form. Each application icon can also be clicked to show a page that contains information about the application's options and build results.

The list of all preprocessor macros (preprocessor icon) and a graphical memory usage map (Linker icon) provide information that is not otherwise readily accessible.

See [Section 4.9 “MPLAB X Option Equivalents”](#), for use of this option in MPLAB X IDE.

## 4.8.36 --LANG: Specify the Language for Messages

This option allows the compiler to be configured to produce error, warning and some advisory messages in languages other than English.

English is the default language unless this has been changed at installation, or by the use of the `--SETUP` option. Some messages are only ever printed in English regardless of the language specified with this option. For more information, see [Section 4.6.2 "Message Language"](#).

[Table 4-15](#) shows those languages currently supported.

**TABLE 4-15: SUPPORTED LANGUAGES**

Suboption	Language
en, english	English (default)
fr, french, francais	French
de, german, deutsch	German

## 4.8.37 --MAXIPIC: Maximize current device's memory resources

The compiler will terminate compilation if the selected device runs out of program memory, data memory, or EEPROM. This option tells the compiler to generate code for a hypothetical device with the same physical core and peripherals as the selected device, but with the maximum allowable memory resources permitted by the device family.

The program memory of PIC18 and mid-range devices will be maximized to either the bottom of external memory or the maximum address permitted by the PC register, whichever is lower. The program memory of baseline parts is maximized to the lower address of the Configuration Words.

The number of data memory banks is expanded to the maximum number of selectable banks as defined by the BSR register (for PIC18 devices), RP bits in the STATUS register (for mid-range devices), or the bank select bits in the FSR register (for baseline devices). The amount of RAM in each additional bank is equal to the size of the largest contiguous memory area within the physically implemented banks.

EEPROM is only maximized if the device implements this memory. If present, EEPROM is maximized to a size dictated by the number of bits in the EEADR register.

If required, check the map file (see [Section 7.4 "Map Files"](#)) to see the size and arrangement of the memory available when using this option with your device.

**Note:** With the `--MAXIPIC` option enabled, you are *not* compiling for a real device. The generated code may not load or execute in simulators or on real silicon devices. This option cannot be used to fit additional code into a device.

You might choose to use this option if your code does not fit in your intended target device. This option will allow you to see the total memory requirements of your program and give an indication of the code or data size reductions that need to be made to fit the program to the device.



## 4.8.38 --MEMMAP: Display Memory Map

This option will display a memory map for the map file specified with this option. The information printed is controlled by the `--SUMMARY` option, see [Section 4.8.61 “--SUMMARY: Select Memory Summary Output Type”](#), for example:

```
xc8 --memmap=size.map --summary=psect,class,file
```

This option is seldom required, but would be useful if the linker is being driven explicitly; i.e., instead of in the normal way through the command-line driver. This command would display the memory summary that is normally produced at the end of compilation by the driver.

## 4.8.39 --MODE: Choose Compiler Operating Mode

This option selects the basic operating mode of the compiler. The available types are `pro`, `std`, and `free`. (For legacy projects, the mode “lite” is accepted to mean the Free operating mode.)

- PRO mode uses full optimization and produces the smallest code size.
- Standard mode uses limited optimizations.
- Free mode uses a minimum optimization level and produces relatively large code.

See [Section 5.13 “Optimizations”](#) and [Section 6.3 “Assembly-Level Optimizations”](#), for more about which optimizations are available in each mode.

Only those modes permitted by the compiler license status are accepted. For example, if you purchased a Standard compiler license, the compiler can be run in Standard or Free mode, but not in PRO mode. If you attempt to run the compiler in a mode for which it is not licensed, it will fall back to the highest-allowed mode.

However, the `--NOFALLBACK` option can be used to detect situations in which a compiler may have been activated incorrectly or not activated at all by preventing compilation in a lower operating mode than the one requested (see [Section 4.8.43 “--NOFALLBACK: Error if the Requested Operating Mode Cannot Be Used”](#)).

See [Section 4.9 “MPLAB X Option Equivalents”](#) for use of this option in MPLAB X IDE.

## 4.8.40 --MSGDISABLE: Disable Warning Messages

This option allows error, warning or advisory messages to be disabled during the compilation of a project.

The option is passed a *comma*-separated list of message numbers that are to be disabled. Any error message numbers in this list are ignored unless they are followed by an `:off` argument. If the message list is specified as `0`, then all warnings are disabled.

For full information on the compiler’s messaging system and use of this option, see [Section 4.6 “Compiler Messages”](#). Also, see [Section 4.6.5 “Changing Message Behavior”](#) for other ways to disable messages.

## 4.8.41 --MSGFORMAT: Set Advisory Message Format

This option sets the format of advisory messages produced by the compiler. Warning and error messages are controlled separately by other options. See [Section 4.8.28 "--ERRFORMAT: Define Format for Compiler Messages"](#) and [Section 4.8.66 "--WARNFORMAT: Set Warning Message Format"](#) for information on changing the format of these sorts of messages.

See [Section 4.6 "Compiler Messages"](#) for full information on the compiler's messaging system.

If you are compiling using MPLAB X IDE, the format of the compiler messages is automatically configured to what the IDE expects. It is recommended that you do not adjust the message formats if compiling using this IDE.

## 4.8.42 --NODEL: Do Not Remove Temporary Files

Specifying `--NODEL` when building will instruct `xc8` not to remove the intermediate and temporary files that were created during the build process.

## 4.8.43 --NOFALLBACK: Error if the Requested Operating Mode Cannot Be Used

This option can be used to ensure that the compiler is not executed with an operating mode below that specified by the `--MODE` option (see [Section 4.8.39 "--MODE: Choose Compiler Operating Mode"](#)). If the compiler has not been activated to run in the requested mode, an error will be produced and compilation will terminate when this option is used. Without this option, the compiler will fall back to either the Standard or Free operating mode if it is not activated to run in the requested mode.

## 4.8.44 --OBJDIR: Specify a Directory for Intermediate Files

This option allows a directory to be nominated in `xc8` to locate its intermediate files. If this option is omitted, intermediate files will be created in the current working directory.

This option will not set the location of output files, instead use `--OUTDIR`. See [Section 4.8.46 "--OUTDIR: Specify a Directory for Output Files"](#) and [Section 4.8.9 "-O: Specify Output File"](#) for more information.

## 4.8.45 --OPT: Invoke Compiler Optimizations

The `--OPT` option allows control of all the compiler optimizers. If this option is not specified, or it is specified as `--OPT=all`, the `space` and `asm` optimizations are enabled (see below). Optimizations can be disabled by using `--OPT=none`, or individual optimizers can be controlled, for example: `--OPT=asm` will only enable some assembler optimizations.

[Table 4-16](#) lists the available optimization types.

**TABLE 4-16: OPTIMIZATION OPTIONS**

Option name	Function
<code>asm</code>	Select optimizations of assembly code derived from C source (default)
<code>asmfile</code>	Select optimizations of assembly source files
<code>debug</code>	Favor accurate debugging over optimization
<code>speed</code>	Favor optimizations that result in faster code
<code>space</code>	Favor optimizations that result in smaller code (default)
<code>all</code>	Enable all compiler optimizations
<code>none</code>	Do not use any compiler optimizations

Note that different suboptions control assembler optimizations of assembly source files and intermediate assembly files produced from C source code.

The `speed` and `space` suboptions are contradictory. Space optimizations are the default. If `speed` and `space` suboptions are both specified, then `speed` optimizations takes precedence. If `all` optimizations are requested, the `space` optimization is enabled. These optimizations affect procedural abstraction, which is performed by the assembler, and other optimizations at the code generation stage.

The `asmfile` selection optimizes assembly source files, which are otherwise not optimized by the compiler. By contrast, the `asm` control allows for optimization of assembly code that was derived from C code, an optimization that is enabled by default.

Enabling the `debug` suboption disables inlining and procedural abstraction (reverse inlining) assembler optimizations. These optimizations can adversely affect source-level debugging.

See [Section 4.9 “MPLAB X Option Equivalents”](#) for use of this option in MPLAB X IDE.

## 4.8.46 --OUTDIR: Specify a Directory for Output Files

This option allows a directory to be nominated for `xc8` to locate its output files. If this option is omitted, output files will be created in the current working directory. See also [Section 4.8.44 “--OBJDIR: Specify a Directory for Intermediate Files”](#) and [Section 4.8.9 “-O: Specify Output File”](#) for more information.

## 4.8.47 --OUTPUT= type: Specify Output File Type

This option allows the type of the output file(s) to be specified. If no `--OUTPUT` option is specified, the output file's name will be the same as the project name (see [Section 4.3 “The Compilation Sequence”](#)).

The available output file formats are shown in [Table 4-17](#). More than one output format can be specified by supplying a *comma*-separated list of tags. Not all formats are supported by Microchip development tools.

For debugging, the ELF/DWARF format is preferred, but this format is not supported by MPLAB 8 IDE or early versions of MPLAB X IDE. Before selecting the ELF file output, ensure your IDE version has support for this format. Microchip COFF is the default debugging file output.

Output file types that specify library formats stop the compilation process before the final stages of compilation are executed. So, specifying an output file format list that contains, for example: `lib` or `all`, will prevent the other formats from being created.

**TABLE 4-17: OUTPUT FILE FORMATS**

Type tag	File format
<code>lib</code>	Object library file (for assembly source)
<code>lpp</code>	P-code library file (for C source)
<code>intel, inhx32</code>	Intel HEX (default)
<code>inhx032</code>	Intel HEX, initialization of upper extended linear address to zero
<code>tek</code>	Tektronix Hex
<code>aahex</code>	American Automation symbolic HEX file
<code>mot, motorola, s19</code>	Motorola S19 HEX file
<code>bin, binary</code>	Binary file
<code>mcof, mcoff, mpcoff</code>	Microchip COFF (default)
<code>elf</code>	ELF/DWARF file

So, for example:

```
xc8 --CHIP=16F877AA --OUTPUT=lpp lcd_init.c lcd_data.c lcd_msgs.c
```

will compile the three names files into an LPP (p-code) library.

#### 4.8.48 --PARSER: Specify Parser Mode

This option controls which symbols are stripped from intermediate (p-code) files produced by the parser. The default is to remove unused symbols, which can also be specified using the `--PARSER=lean` mode. The `rich` mode will not remove any symbols.

Note that the `rich` mode will generate larger intermediate files and will considerably slow down the compilation, particularly if there are many SFRs defined for a device. PIC18 devices typically have a large number of SFRs. Use the `rich` setting if you have in-line assembly code that accesses symbols that are not referenced by C code otherwise undefined symbol errors can be produced by the assembler application.

#### 4.8.49 --PASS1: Compile to P-code

The `--PASS1` option is used to generate p-code intermediate files (`.p1` files) from the parser, and then stop compilation. Such files need to be generated if creating p-code library files, however the compiler is able to generate library files in one step, if required. See [Section 4.8.47 "--OUTPUT= type: Specify Output File Type"](#) for specifying a library output file type.)

## 4.8.50 --PRE: Produce Preprocessed Source Code

The `--PRE` option is used to generate preprocessed C source files (also called modules or translation units) with an extension `.pre`. This can be useful to ensure that preprocessor macros have expanded to what you think they should. Use of this option can also create C source files that do not require any separate header files. If the `.pre` files are renamed to `.c` files, they can be passed to the compiler for subsequent processing. This is useful when sending files to a colleague or to obtain technical support without sending all the header files, which can reside in many directories.

If you wish to see the preprocessed source for the `printf()` family of functions, do *not* use this option. The source for this function is customized by the compiler, but only after the code generator has scanned the project for `printf()` usage. Thus, as the `--PRE` option stops compilation after the preprocessor stage, the code generator will not execute and no `printf()` code will be processed. If this option is omitted, the preprocessed source for `printf()` will be automatically retained in the file `doprnt.pre`.

## 4.8.51 --PROTO: Generate Prototypes

The `--PROTO` option is used to generate `.pro` files containing both ANSI C and K&R style function declarations for all functions within the specified source files. Each `.pro` file produced will have the same base name as the corresponding source file. Prototype files contain both ANSI C-style prototypes and old-style C function declarations within conditional compilation blocks.

The `extern` declarations from each `.pro` file should be edited into a global header file, which can then be included into all the C source files in the project. The `.pro` files can also contain `static` declarations for functions that are local to a source file. These `static` declarations should be edited into the start of the source file.

To demonstrate the operation of the `--PROTO` option, enter the following source code as file `test.c`:

```
#include <stdio.h>
add(arg1, arg2)
int *   arg1;
int *   arg2;
{
    return *arg1 + *arg2;
}

void printlist(int * list, int count) {
    while (count--)
        printf("d " *list++);
    putchar('\n');
}
```

If compiled with the command:

```
xc8 --CHIP=16F877AA --PROTO test.c
```

`xc8` will produce `test.pro` containing the following declarations, which can then be edited as necessary:

```
/* Prototypes from test.c */
/* extern functions - include these in a header file */
#if     PROTOTYPES
extern int add(int *, int *);
extern void printlist(int *, int);
#else   /* PROTOTYPES */
extern int add();
extern void printlist();
#endif   /* PROTOTYPES */
```

## 4.8.52 --RAM: Adjust RAM Ranges

This option is used to adjust the default RAM, which is specified for the target device. The default memory will include all the on-chip RAM specified for the target PIC10/12/16 device, thus this option only needs be used if there are special memory requirements. Typically this option is used to reserve memory (reduce the amount of memory available). Specifying additional memory that is not in the target device will typically result in a successful compilation, but can lead to code failures at runtime.

The default RAM memory for each target device is specified in the chipinfo file, `picc.ini`.

Strictly speaking, this option specifies the areas of memory that can be used by writable (RAM-based) objects; but, not necessarily those areas of memory that contain physical RAM. The output that will be placed in the ranges specified by this option are typically variables that a program defines.

For example, to specify an additional range of memory to that already present on-chip, use:

```
--RAM=default,+100-1ff
```

This will add the range from 100h to 1ffh to the on-chip memory. To only use an external range and ignore any on-chip memory, use:

```
--RAM=0-ff
```

This option can also be used to reserve memory ranges already defined as on-chip memory in the chipinfo file. To do this, supply a range prefixed with a minus character, `-`, for example:

```
--RAM=default,-100-103
```

will use all the defined on-chip memory, but not use the addresses in the range from 100h to 103h for allocation of RAM objects.

This option is also used to specify RAM for `far` objects on PIC18 devices. These objects are stored in the PIC18 extended memory. Any additional memory specified with this option whose address is above the on-chip program memory is assumed to be extended memory implemented as RAM.

For example, to indicate that RAM has been implemented in the extended memory space at addresses 0x20000 to 0x20fff, use the following option.

```
--RAM=default,+20000-20fff
```

This option will adjust the memory ranges used by linker classes (see [Section 7.2.1 “-Aclass =low-high,...”](#)) so any object that is in a psect is placed in this class. Any objects contained in a psect that are explicitly placed at a memory address by the linker (see [Section 7.2.18 “-Pspec”](#)), i.e., are not placed into a memory class, are not affected by the option. For an introductory guide to psects, see [Section 5.15.1 “Program Sections”](#).

See [Section 4.9 “MPLAB X Option Equivalents”](#) for use of this option in MPLAB X IDE.

## 4.8.53 --ROM: Adjust ROM Ranges

This option is used to change the default ROM that is specified for the target device. The default memory will include all the on-chip ROM specified for the target PIC10/12/16 device, thus this option only needs to be used if there are special memory requirements. Typically this option is used to reserve memory (reduce the amount of memory available). Specifying additional memory that is not in the target device will typically result in a successful compilation, but can lead to code failures at runtime.

The default ROM memory for each target device is specified in the chipinfo file, `picc.ini`.

Strictly speaking, this option specifies the areas of memory that can be used by read-only (ROM-based) objects; but, not necessarily those areas of memory that contain physical ROM. When producing code that can be downloaded into a system via a bootloader, the destination memory can be some sort of (volatile) RAM. The output that will be placed in the ranges specified by this option are typically executable code and any data variables that are qualified as `const`.

For example, to specify an additional range of memory to that on-chip, use:

```
--ROM=default,+100-2ff
```

This will add the range from 100h to 2ffh to the on-chip memory. To only use an external range and ignore any on-chip memory, use:

```
--ROM=100-2ff
```

This option can also be used to reserve memory ranges already defined as on-chip memory in the chip configuration file. To do this supply a range prefixed with a minus character, `-`, for example:

```
--ROM=default,-100-1ff
```

will use all the defined on-chip memory, but not use the addresses in the range from 100h to 1ffh for allocation of ROM objects.

This option will adjust the memory ranges used by linker classes (see [Section 7.2.1 “-Aclass =low-high,...”](#)) so any object that is in a psect is placed in this class. Any objects which are contained in a psect that are explicitly placed at a memory address by the linker (see [Section 7.2.18 “-Pspec”](#)), i.e., are not placed into a memory class, are not affected by the option. For an introductory guide to psects, see [Section 5.15.1 “Program Sections”](#).

Note that some psects must be linked above a threshold address, most notably some psects that hold `const` data. Using this option to remove the upper memory ranges can make it impossible to place these psects.

See [Section 4.9 “MPLAB X Option Equivalents”](#) for use of this option in MPLAB X IDE.

## 4.8.54 --RUNTIME: Specify Runtime Environment

The `--RUNTIME` option is used to control what is included as part of the runtime environment. In this context, the runtime environment encapsulates any code that is present when the program is executing and that has not been defined by the user. Such code is supplied by the compiler, typically in library files or compiler-generated source files built alongside the user's code.

All required runtime features are enabled by default and this option is not required for normal compilation.

Note that the code that clears or initializes variables, which is included by default, will clobber the contents of the STATUS register. For mid-range and baseline devices, if you need to check the cause of Reset using the TO or PD bits in this register, then you can enable the `resetbits` suboption as well. See [Section 5.10.1.4 "STATUS Register Preservation"](#) for how this feature is used.

The usable suboptions include those shown in [Table 4-18](#).

**TABLE 4-18: RUNTIME ENVIRONMENT SUBOPTIONS**

Suboption	Controls	On (+) Implies	Default State
<code>init</code>	the code present in the main program module that copies the ROM-image of initial values to RAM variables	The ROM image is copied into RAM and initialized variables will contain their initial value at <code>main()</code> .	On
<code>clear</code>	the code present in the main program module that clears uninitialized variables	Uninitialized variables are cleared and will contain 0 at <code>main()</code> .	On
<code>config</code>	programming the device with default config bytes	Configuration bits not specified will be assigned a default value. (PIC18 only)	Off
<code>download</code>	conditioning of the Intel HEX file for use with bootloaders	Data records in the Intel HEX file are padded out to 16-byte lengths and will align on 16-byte boundaries. Startup code will not assume Reset values in certain registers.	Off
<code>flp</code>	additional code to provide function profiling	Diagnostic code will be embedded into the output to allow function profiling.	Off
<code>no_startup</code>	whether the startup module is linked in with user-defined code	Startup module will not be linked in.	Off
<code>ivt[:addr]</code>	enabling use and selection of the interrupt vector table	A vector table will be selected by writing <code>addr</code> to the IVTBASE register during startup	On
<code>osccal</code>	initialize the oscillator with the oscillator constant	Oscillator will be calibrated (PIC10/12/16 only).	On
<code>osccal: value</code>	set the internal clock oscillator calibration value	Oscillator will be calibrated with <code>value</code> supplied (PIC10/12/16 only).	n/a
<code>keep</code>	whether the startup module source file ( <code>startup.as</code> ) is deleted after compilation	The startup module is not deleted.	On
<code>plib</code>	whether the peripheral library is linked in.	The peripheral library will be linked in to the build (PIC18 only).	On
<code>resetbits</code>	preserve Power-down and Time-out STATUS bits at start up	STATUS bits are preserved (PIC10/12/16 only).	Off
<code>stackcall</code>	allow function calls to use a table look-up method after the hardware stack has filled (Ignored if reentrant or hybrid function model is used, or if function uses the <code>reentrant</code> specifier.)	Functions called via <code>CALL</code> instruction while the stack was not exhausted, then called via a look-up table (PIC10/12/16 devices only).	Off

See [Section 4.9 "MPLAB X Option Equivalents"](#) for use of this option in MPLAB X IDE.



## 4.8.55 --SCANDEP: Scan for Dependencies

When this option is used, `.dep` and `.d` dependency files are generated. The dependency file lists those files on which the source file is Dependant. Dependencies result when one file is `#included` into another. The `.d` file format is used by GCC-based compilers and it contains the same information as the `.dep` file.

Compilation will stop after the preprocessing stage if this option is used.

This option is equivalent to `--DEP=list,gcc,sys,stop`, see [Section 4.8.23 "--DEP: Generate dependency file"](#).

## 4.8.56 --SERIAL: Store a Value at this Program Memory Address

This option allows a hexadecimal code to be stored at a particular address in program memory. A typical task for this option might be to position a serial number in program memory.

The byte-width of data to store is determined by the byte-width of the hexcode parameter in the option. For example, to store a one-byte value, 0, at program memory address 1000h, use `--SERIAL=00@1000`. To store the same value as a four byte quantity use `--SERIAL=00000000@1000`.

This option is functionally identical to the corresponding `HEXMATE` option. For more detailed information and advanced controls that can be used with this option, refer to [Section 8.3.1.15 "-SERIAL"](#).

The driver will also define a label at the location where the value was stored, and which can be referenced from C code as `_serial0`. To enable access to this symbol, remember to declare it, for example:

```
extern const int _serial0;
```

See [Section 4.9 "MPLAB X Option Equivalents"](#), for use of this option in MPLAB X IDE.

## 4.8.57 --SETOPTION: Set the Command-line Options for Application

This option is used to supply alternative command line options for the named application when compiling. The general form of this option is shown below.

```
--SETOPTION=app, file
```

where the *app* component specifies the application that will receive the new options, and the *file* component specifies the name of the file that contains the additional options that will be passed to the application. This option is not required for most projects.

If specifying more than one option to a component, each option must be entered on a new line in the option file. This option can also be used to remove an application from the build sequence. If the *file* parameter is specified as *off*, execution of the named application will be skipped. In most cases, this is not desirable as almost all applications are critical to the success of the build process. Disabling a critical application will result in catastrophic failure. However, it is permissible to skip a non-critical application such as `CLIST` or `HEXMATE`, if the final results are not relying on their function.

## 4.8.58 --SHROUD: Obfuscate P-code Files

This option should be used in situations where either p-code files or p-code libraries are to be distributed and are built from confidential source code.

C comments, which are normally included into these files, as well as line numbers and variable names will be removed, or obfuscated, so that the original source code cannot be reconstructed from the distributed files.

## 4.8.59 --STACK: Specify Data Stack Type For Entire Program

This option allows selection of the stack type to be used by a program's stack-based (`auto` and parameter) variables. The data stacks available are called a compiled stack and a software stack, and they are described in [Section 5.3.4.2 "Data Stacks"](#). The stack types that can be used with this option are described in [Table 4-19](#).

**TABLE 4-19: --STACK SUBOPTIONS**

Stack types	Default Allocation for Stack-based Variables
<code>compiled</code> or <code>nonreentrant</code>	Use the compiled stack for all functions; functions are non-reentrant (default).
<code>software</code> or <code>reentrant</code>	Use the software stack for eligible functions and devices; such functions are reentrant.
<code>hybrid</code>	Use the compiled stack for functions not called reentrantly; use the software stack for all other eligible functions and devices; functions are only reentrant if required.

Suboptions that specify reentrancy only affect target devices that support a software stack. Functions encoded for baseline and mid-range devices always use the compiled stack. In addition, not all functions can use a software stack. Interrupt functions must use the compiled stack, but functions they call may use the software stack.

The `hybrid` setting forces the compiler to consider both a compiled and software stack for the program's stack-based variables. The software stack will only be used if the functions and device supports reentrancy. This mode allows for reentrancy, when required, but takes advantage of the efficiency of the compiled stack for the majority of the program's functions. A function is compiled to use the software stack if it is called reentrantly in the program; otherwise, it will use a compiled stack.

Any of these option settings can be overridden for individual functions by using function specifiers, described in [Section 5.8.1.3 "Reentrant and nonreentrant Specifiers"](#).

**Note:** Use the `software (reentrant)` setting with caution. The maximum runtime size of the software stack is not accurately known at compile time, so the compiler cannot warn of memory overwrites. The stack can overflow and corrupt objects or data memory used by something outside the program (such as hardware or another independently-compiled applications). When all functions are forced to use the software stack, the stack size will increase substantially.

In addition to the stack type, this option can be used to specify the maximum size of memory reserved by the compiler for the software stack. This option configuration only affects the software stack; there are no controls for the size of the compiled stack.

Distinct memory areas are allocated for the software stack that is used by main-line code and each interrupt function. Basically, there are separate stacks for each interrupt and main-line code, but this is transparent at the program level. The compiler automatically manages the allocation of memory to each stack. If your program does not define any interrupt functions, all the available memory is made available to the software stack used by main-line code; but, you can explicitly allocate memory.

You can manually specify the maximum space allocated for each stack by following the stack type with a colon-separated list of decimal values, each value being the maximum size, in bytes, of the memory to be reserved. The sizes specified correspond to the main-line code, the lowest priority interrupt through the highest priority interrupt. (PIC18 devices have two separate interrupts; other devices have only one.) Alternatively, you can explicitly state that you have no size preference by using a size of `auto`. For PIC18 devices, the following example:

```
--STACK=reentrant:auto:30:50
```

will arrange the stack starting locations so that the low-priority interrupt stack can grow to, at most, 30 bytes (before overflow); the high-priority interrupt stack can grow to, at most, 50 bytes (before overflow); and the main-line code stack can consume the remainder of the free memory that can be allocated to the stack (before overflow). If you are compiling for a PIC18 device and only one interrupt is used, it is recommended that you explicitly set the unused interrupt stack size to zero using this option.

If you do specify the stack sizes using this option, each size must be specified numerically or you can use the `auto` token. Do not leave a size field empty. If you try to use this option to allocate more stack memory than is available, a warning is issued and only the available memory will be utilized.

#### 4.8.60 --STRICT: Strict ANSI Conformance

The `--STRICT` option is used to enable strict ANSI C conformance of all special, non-standard keywords.

The MPLAB XC8 C compiler supports various special keywords (for example the `persistent` type qualifier). If the `--STRICT` option is used, these keywords are changed to include two *underscore* characters at the beginning of the keyword (for example, `__persistent`) so as to strictly conform to the ANSI standard. Thus if you use this option, you will need to use the qualifier `__persistent` in your code, not `persistent`.

Be warned that use of this option can cause problems with some standard header files (e.g., `<xc.h>`) as they contain special keywords.

See [Section 4.9 "MPLAB X Option Equivalents"](#), for use of this option in MPLAB X IDE.

## 4.8.61 --SUMMARY: Select Memory Summary Output Type

Use this option to select the type of memory summary that is displayed after compilation. By default, or if the `mem` suboption is selected, a memory summary is shown. This shows the total memory usage for all memory spaces.

A `psect` summary can be shown by enabling the `psect` suboption. This shows individual `psects`, after they have been grouped by the linker, and the memory ranges they cover. [Table 4-20](#) shows what summary types are available. The output printed when compiling normally corresponds to the `mem` setting.

**TABLE 4-20: MEMORY SUMMARY SUBOPTIONS**

Suboption	Controls
<code>psect</code>	A summary of <code>psect</code> names and the addresses where they were linked will be shown.
<code>mem</code>	A concise summary of memory used will be shown. (default)
<code>class</code>	A summary of all classes in each memory space will be shown.
<code>hex</code>	A summary of addresses and HEX files that make up the final output file will be shown.
<code>file</code>	Summary information will be shown on screen and saved to a file.
<code>xml</code>	Summary information will be shown on the screen, and usage information for the main memory spaces will be saved in an XML file
<code>xmlfull</code>	Summary information will be shown on the screen, and usage information for all memory spaces will be saved in an XML file

If produced, the XML files contain information about memory spaces on the selected device – consisting of the space's name, addressable unit, size, amount used and amount free.

See [Section 4.9 "MPLAB X Option Equivalents"](#) for use of this option in MPLAB X IDE.

## 4.8.62 --TIME: Report Time Taken For Each Phase of Build Process

Adding the `--TIME` option when building generates a summary that shows how much time elapsed during each stage of the build process.

## 4.8.63 --UNDEFINTS: Program Unused Interrupt Vectors

This option allows you to control how the compiler responds to uninitialized interrupt vectors, including undefined legacy low- and high-priority vectors, and entries in the interrupt vector table. A warning is generated if any uninitialized vectors are detected, except if the `ignore` suboption is specified.

The suboptions are shown in [Table 4-21](#) as well as the corresponding actions taken for projects that are using the Interrupt Controller Macro (ICM) module and for all other projects (which are those projects using devices that do not have the ICM, or those projects in which the vector tables are disabled and the device is running in legacy mode).

For example, to have a software breakpoint executed by any vector location that is not linked to an interrupt function, use the option `--UNDEFINTS:swbp`.

The default action for projects using the ICM is to program the address of a `RESET` instruction (which will be located immediately after the vector table) into each unassigned vector location; for all other devices, it is to leave the locations unprogrammed and available for other use.

If the target device does not implement a `RESET` instruction or software breakpoint instruction and execution of these instructions have been requested for unused vectors, an instruction that can jump to itself will be programmed instead.

**TABLE 4-21: UNUSED INTERRUPT SUBOPTIONS**

Suboption	Action for devices using the ICM	Action for all other devices
<code>ignore</code>	No action; vector location available for program code.	No action; vector location available for program code (default).
<code>reset</code>	Program each unassigned vector with the address of a <code>RESET</code> instruction (default).	Program a <code>RESET</code> instruction at each unassigned vector.
<code>swbp</code>	Program each unassigned vector with the address of a software breakpoint instruction.	Program a software breakpoint instruction at each unassigned vector.

An interrupt function can be assigned to any otherwise unassigned vector location by using the `default` interrupt source when defining that function, see [Section 5.9.1 “Writing an Interrupt Service Routine”](#).

The `--UNDEFINTS` option is ignored if the target device does not support interrupts.

#### 4.8.64 `--VER`: Display the Compiler’s Version Information

The `--VER` option will display which version of the compiler is running, and then exit the compiler.

#### 4.8.65 `--WARN`: Set Warning Level

The `--WARN` option is used to set the compiler warning level threshold. Allowable warning levels range from -9 to 9. The warning level determines how pedantic the compiler is about dubious type conversions and constructs. Each compiler warning has a designated warning level; the higher the warning level, the more important the warning message. If the warning message’s warning level exceeds the set threshold, the warning is printed by the compiler. The default warning level threshold is 0 and will allow all normal warning messages.

Use this option with care as some warning messages indicate code that is likely to fail during execution, or compromise portability.

Warning message can be individually disabled with the `--MSGDISABLE` option, see [Section 4.8.40 “--MSGDISABLE: Disable Warning Messages”](#). See also [Section 4.6 “Compiler Messages”](#) for full information on the compiler’s messaging system.

See [Section 4.9 “MPLAB X Option Equivalents”](#) for use of this option in MPLAB X IDE.

#### 4.8.66 `--WARNFORMAT`: Set Warning Message Format

This option sets the format of warning messages produced by the compiler. See [Section 4.8.28 “--ERRFORMAT: Define Format for Compiler Messages”](#) for more information on this option. For full information on the compiler’s messaging system, see [Section 4.6 “Compiler Messages”](#).

If you are compiling using MPLAB X IDE, the format of the compiler messages is automatically configured to what the IDE expects. It is recommended that you do not adjust the message formats if compiling using this IDE.

## 4.9 MPLAB X OPTION EQUIVALENTS

Even when compiling under the MPLAB X IDE, it is still the compiler's command-line driver that is being executed and compiling the program. The MPLAB XC8 compiler plugins control the MPLAB X IDE Properties dialog that is used to access the compiler options. However, these graphical controls ultimately adjust the command-line options passed to the command-line driver when compiling. You can see the command-line options being used when building in MPLAB X IDE in the Output window.

The following dialogs and descriptions identify the mapping between the MPLAB X IDE dialog controls and command-line options. Click any option to see online help and examples shown in the Option Description field in the lower part of the Project Properties dialog.

### 4.9.1 Global Category

The options in the panel of this category control the final output of the compiler.

#### 4.9.1.1 GLOBAL OPTIONS

See [Figure 4-5](#) in conjunction with the following command-line option equivalent.

**FIGURE 4-5: GLOBAL OPTIONS**

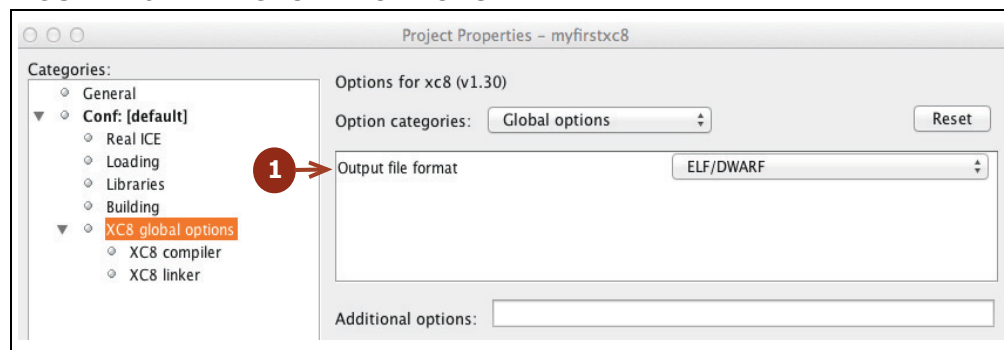

#### Output file format

This selector specifies the output source-level debug format that will be used by debuggers, see [Section 4.8.47 "--OUTPUT= type: Specify Output File Type"](#).

#### 4.9.1.2 STACK OPTIONS

See [Figure 4-6](#) in conjunction with the following command-line option equivalent.

**FIGURE 4-6: STACK OPTIONS**

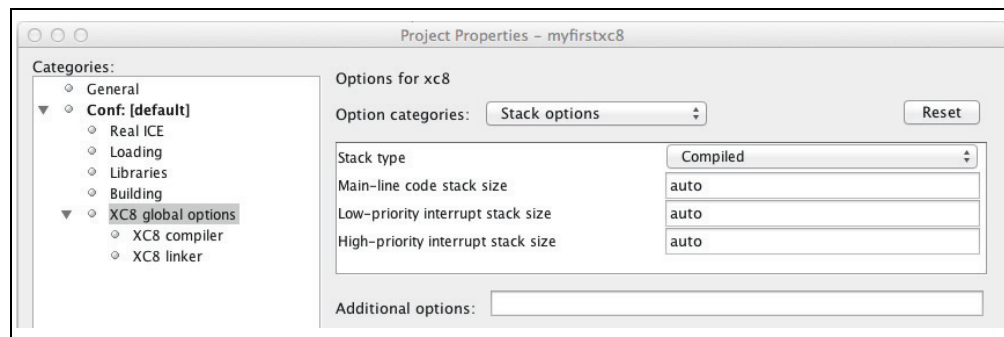

All the widgets in [Figure 4-6](#) correspond to suboptions of the `--STACK` option, see [Section 4.8.59 "--STACK: Specify Data Stack Type For Entire Program"](#).

## 4.9.2 Compiler Category

The panels in this category control aspects of compilation of C source.

### 4.9.2.1 PREPROCESSING AND MESSAGES

These options relate to the C preprocessor and messages produced by the compiler, see [Section 4.6 “Compiler Messages”](#) for more information.

See [Figure 4-7](#) in conjunction with the following command-line option equivalents.

**FIGURE 4-7: PREPROCESSING AND MESSAGES OPTIONS**

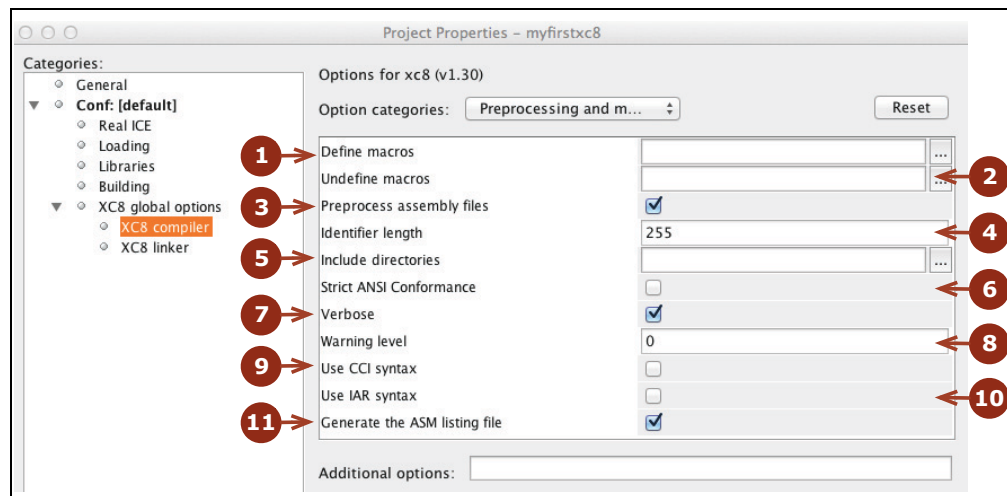

1. Define macros  
The button and field on this line can be used to define preprocessor macros, see [Section 4.8.2 “-D: Define Macro”](#).
2. Undefine macros  
The button and field on this line can be used to undefine preprocessor macros, see [Section 4.8.13 “-U: Undefine a Macro”](#).
3. Preprocess assembly files  
This checkbox controls whether assembly source files are scanned by the preprocessor, see [Section 4.8.10 “-P: Preprocess Assembly Files”](#).
4. Identifier length  
Not implemented, see [Section 4.8.8 “-N: Identifier Length”](#).
5. Include directories  
This selection uses the buttons and fields grouped in the bracket to specify include (header) file search directories, see [Section 4.8.4 “-I: Include Search Path”](#).
6. Strict ANSI Conformance  
This forces the compiler to reject any non-standard keywords, see [Section 4.8.60 “--STRICT: Strict ANSI Conformance”](#).
7. Verbose  
This checkbox controls whether the full command lines for the compiler applications are displayed when building, see [Section 4.8.14 “-V: Verbose Compile”](#).
8. Warning level  
This selector allows the warning level print threshold to be set, see [Section 4.8.65 “--WARN: Set Warning Level”](#).



## 9. Use CCI Syntax

This option indicates that the compiler should use the Common C Interface compiler extensions, see [Section 4.8.30 “--EXT: Specify C Language Extensions”](#), and [Chapter 2. Common C Interface](#), for more information.

## 10. Use IAR Syntax

This option indicates that the compiler should use the IAR compiler extensions, see [Section 4.8.30 “--EXT: Specify C Language Extensions”](#).

## 11. Generate the ASM listing file

This option indicates that the compiler should generate an assembly listing file. This file should be used to examine the assembly code produced by the compiler, see [Section 4.8.16 “--ASMLIST: Generate Assembler List Files”](#).

### 4.9.2.2 OPTIMIZATIONS

These options, shown in [Figure 4-8](#), relate to optimizations performed by the compiler.

#### 1. Disable optimizations

This control acts like a master disable for all optimizations. Selecting this control turns off all C- and assembler-level optimizations.

#### 2. Individual optimization controls

Provided the above master control is enabled, these controls allow control over which and how optimizations are performed. They control optimization of assembly code produced from C source (*asm*), optimization of hand-written assembly source modules (*asmfile*), whether optimizations should aim to produce the smallest or fastest output (*space/speed*), and whether optimizations should be limited to only those that do not significantly affect the debugability of source code (*debug*). See [Section 4.8.45 “--OPT: Invoke Compiler Optimizations”](#) for more information on the `--OPT` suboptions bracketed above.

#### 3. Address qualifiers

This selector allows the user to select the behavior of the address qualifiers, see [Section 4.8.15 “--ADDRQUAL: Set Compiler Response to Memory Qualifiers”](#).

#### 4. Operation mode

This selector allows the user to force another available operating mode (*free*, *std*, or *pro*) other than the default, see [Section 4.8.39 “--MODE: Choose Compiler Operating Mode”](#). The operating mode affects OCG-optimizations.

**FIGURE 4-8: OPTIMIZATIONS OPTIONS**

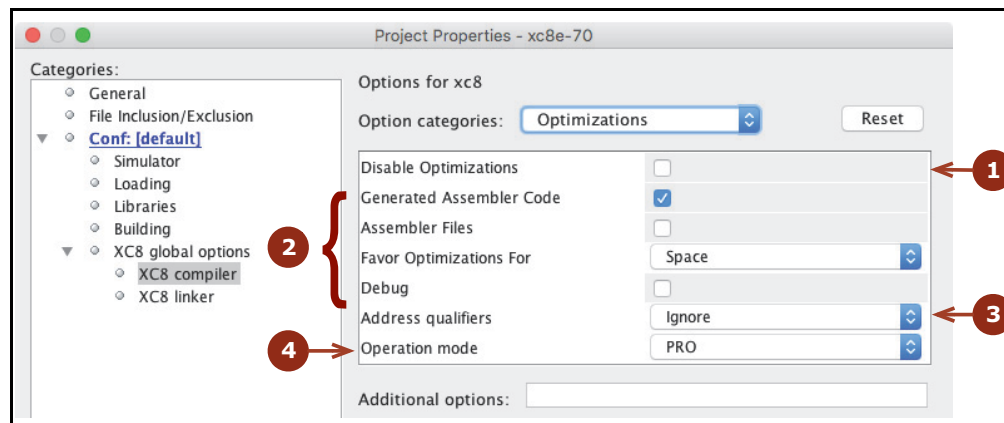



## 4.9.3 Linker Category

The options in this dialog control the aspects of the second stage of compilation including code generation and linking.

### 4.9.3.1 RUNTIME

All the widgets in [Figure 4-9](#) correspond to suboptions of the `--RUNTIME` option, see [Section 4.8.54 “--RUNTIME: Specify Runtime Environment”](#). Respectively, these map to the `clear`, `init`, `keep`, `no_startup`, `osccal`, `osccval`, `resetbits`, `download`, `stackcall`, `config`, `clib` (now defunct) and `plib` suboptions of the `--RUNTIME` option.

**FIGURE 4-9: RUNTIME OPTIONS**

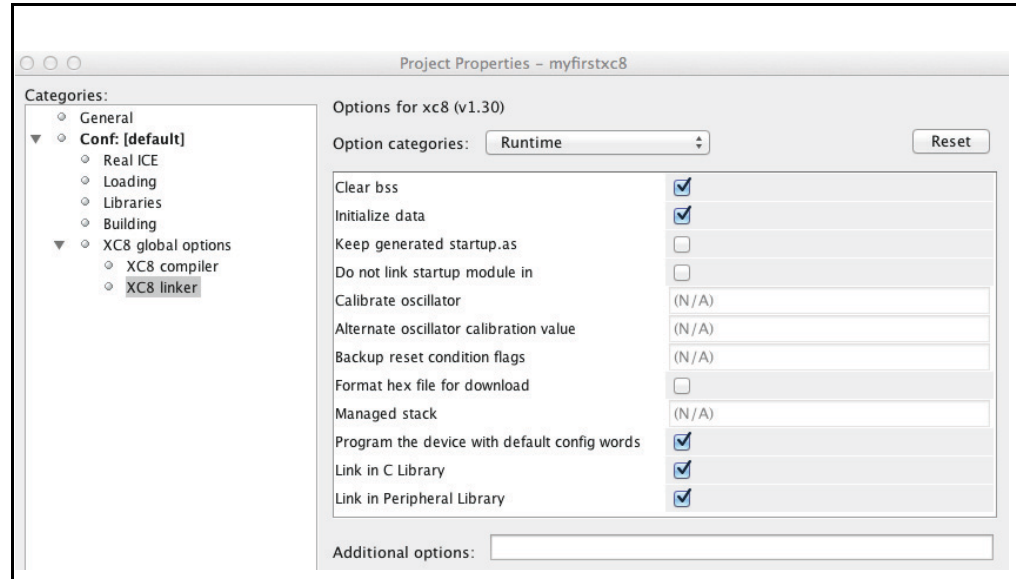

## 4.9.3.2 MEMORY MODEL

The panel in this category, shown in [Figure 4-10](#), controls settings that apply to the entire project.

**FIGURE 4-10: MEMORY MODEL OPTIONS**

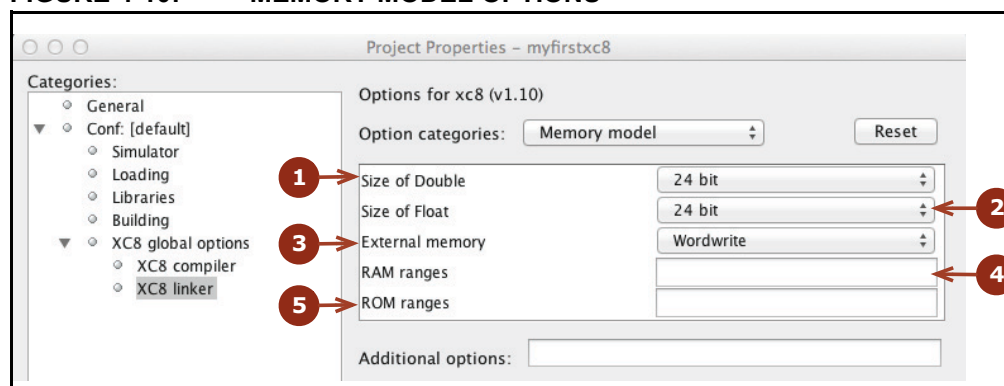

1. Size of Double  
This selector allows the size of the `double` type to be selected, see [Section 4.8.24 "--DOUBLE: Select Kind of Double Types"](#).
2. Size of Float  
This selector allows the size of the `float` type to be selected, see [Section 4.8.32 "--FLOAT: Select Kind of Float Types"](#).
3. External memory  
This option allows specification of how external memory access is performed. This only affects those devices that can access external memory, see [Section 4.8.26 "--EMI: Select External Memory Interface Operating Mode"](#).
4. RAM ranges  
This field allows the default RAM (data space) memory used to be adjusted, see [Section 4.8.52 "--RAM: Adjust RAM Ranges"](#).
5. ROM ranges  
This field allows the default ROM (program memory space) memory used to be adjusted, see [Section 4.8.53 "--ROM: Adjust ROM Ranges"](#).

## 4.9.3.3 FILL FLASH MEMORY

All the controls shown in [Figure 4-11](#) relate to options associated with filling unused program memory. See [Section 4.8.31 “--FILL: Fill Unused Program Memory”](#), for more information on the different fields.

**FIGURE 4-11: FILL FLASH MEMORY OPTIONS**

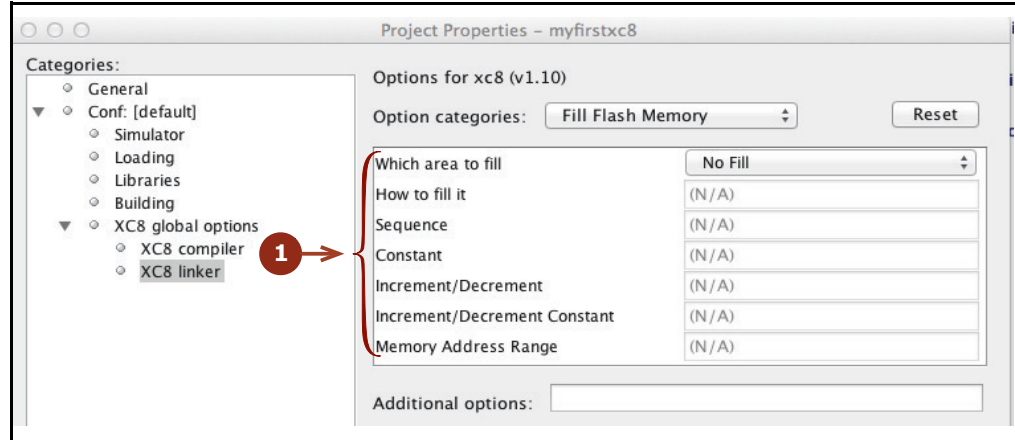

## 4.9.3.4 ADDITIONAL

The options shown in [Figure 4-12](#) relate to miscellaneous options.

1. Extra linker options  
This field allows you to enter additional options to the linker. Enter the entire `-L-` option in this field, for example `-L-pmytest=300h`. See [Section 4.8.6 “-L: Adjust Linker Options Directly”](#).
2. Serial  
This option allows you to specify a string that can be inserted into your output HEX file. See [Section 4.8.56 “--SERIAL: Store a Value at this Program Memory Address”](#), for details.
3. Codeoffset  
This field allows an offset for the program to be specified, see [Section 4.8.20 “--CLIST: Generate C Listing File”](#).
4. Checksum  
This field allows the checksum specification to be specified, see [Section 4.8.17 “--CHECKSUM: Calculate a Checksum”](#).
5. Errata  
This allows customization of the errata workarounds applied by the compiler, see [Section 4.8.27 “--ERRATA: Specify Errata Workarounds”](#).
6. Trace type  
Not implemented. Native trace supported.
7. Extend address 0 in HEX file  
This option specifies that the Intel HEX file should have initialization to zero of the upper address, see [Section 4.8.47 “--OUTPUT= type: Specify Output File Type”](#).
8. Use response file to link  
This option allows a file name to be specified. The file must contain command-line options which are then used by MPLAB XC8 during the link step and in preference to the other link-step settings in the project properties, see [Section 4.2.1.1 “Long Command Lines”](#). This option is only relevant when running MPLAB X IDE under Windows.

**FIGURE 4-12: ADDITIONAL OPTIONS**

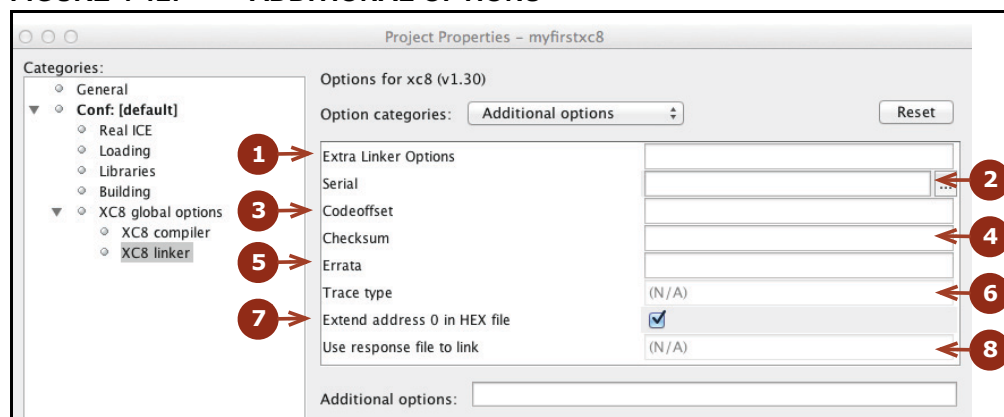

## 4.9.3.5 REPORTING

These options, shown in [Figure 4-13](#) relate to information produced during and after compilation.

1. Display memory usage after compilation  
These checkboxes allow you to specify what information is displayed after compilation. The correspond to the `psect`, `class`, `mem` and `hex` suboptions to the `--SUMMARY` option, see [Section 4.8.61 “--SUMMARY: Select Memory Summary Output Type”](#).
2. Create summary file  
Selecting this checkbox will send the information you have selected above to a file, as well as to the standard output. This corresponds to the `file` suboption to the `--SUMMARY` option, see [Section 4.8.61 “--SUMMARY: Select Memory Summary Output Type”](#).
3. Create html files  
This will create HTML files summarizing the previous build, see [Section 4.8.35 “--HTML: Generate HTML Diagnostic Files”](#).

**FIGURE 4-13: REPORTING OPTIONS**

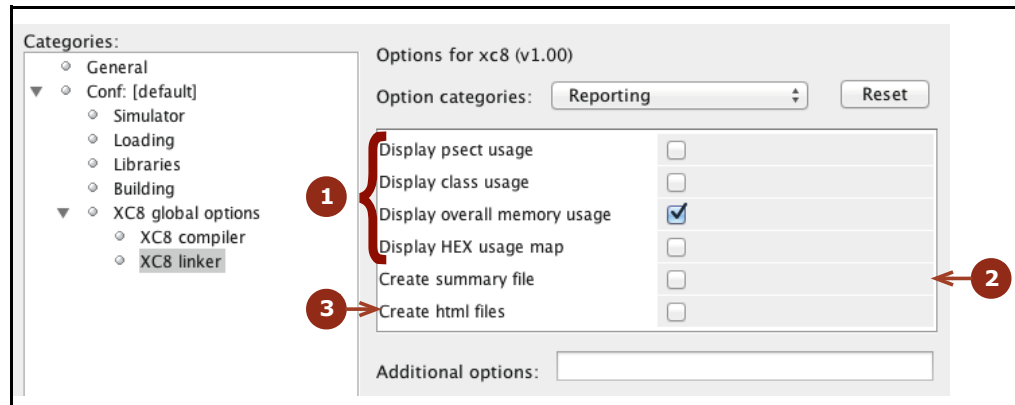

# MPLAB® XC8 C Compiler User's Guide

---

NOTES:

---

---

## Chapter 5. C Language Features

---

---

### 5.1 INTRODUCTION

MPLAB XC8 C Compiler supports a number of special features and extensions to the C language which are designed to ease the task of producing ROM-based applications for 8-bit PIC devices. This chapter documents the special language features which are specific to these devices.

- [ANSI C Standard Issues](#)
- [Device-Related Features](#)
- [Supported Data Types and Variables](#)
- [Memory Allocation and Access](#)
- [Operators and Statements](#)
- [Register Usage](#)
- [Functions](#)
- [Interrupts](#)
- [Main, Runtime Startup and Reset](#)
- [Libraries](#)
- [Mixing C and Assembly Code](#)
- [Optimizations](#)
- [Preprocessing](#)
- [Linking Programs](#)

### 5.2 ANSI C STANDARD ISSUES

This compiler conforms to the ISO/IEC 9899:1990 Standard for programming languages. This is commonly called the C90 Standard. It is referred to as the ANSI C Standard in this manual.

Some violations to the ANSI C Standard are discussed in this section, as well as some features from the later standard C99 that are supported.

#### 5.2.1 Divergence from the ANSI C Standard

The C language implemented on MPLAB XC8 C Compiler can diverge from the ANSI C Standard in several areas.

One divergence is due to limited device memory and no hardware implementation of a data stack. For this reason, recursion is not supported and functions are not reentrant on baseline and some mid-range devices. Functions can be encoded reentrantly for enhanced mid-range and PIC18 devices. See [Section 5.3.4 "Stacks"](#) for more information on the stack models used by the compiler for each device family.

For those devices that do not support reentrancy, the compiler can make functions called from main-line and interrupt code appear to be reentrant via a duplication feature. See [Section 5.9.7 "Function Duplication"](#) for more about duplication.

Another divergence from the Standard is that you cannot reliably use the C `sizeof` operator with pointer types; however, this operator may be used with pointer variable identifiers. This is a result of the dynamic size of pointers assigned by the compiler.

So, for the following code:

```
char * cp;
size_t size;
size = sizeof(char *);
size = sizeof(cp);
```

`size` in the first example will be assigned the maximum size a pointer can be for the particular target device you have chosen. In the second example, `size` will be assigned the actual size of the pointer variable, `cp`. The `sizeof` operator using a pointer variable operand cannot be used as the number-of-elements expression in an array declaration. For example, the size of the following array is unpredictable:

```
unsigned buffer[sizeof(cp) * 10];
```

## 5.2.2 Implementation-Defined behavior

Certain features of the ANSI C standard have implementation-defined behavior. This means that the exact behavior of some C code can vary from compiler to compiler. The exact behavior of the compiler is detailed throughout this manual, and is fully summarized in [Appendix D. Implementation-Defined Behavior](#).

## 5.2.3 Common C Interface Standard

This compiler conforms to the Microchip XC compiler Common C Interface standard (CCI). This is a further refinement of the ANSI standard that attempts to standardize implementation-defined behavior and non-standard extensions across the entire MPLAB XC compiler family. It is described in [Chapter 2. Common C Interface](#).

MPLAB XC8 accepts all CCI extensions in all language extension modes except for IAR compatibility mode. However, if you choose to write code that must conform to this standard, the compiler option (see [Section 4.8.30 “--EXT: Specify C Language Extensions”](#)) should be enabled. This option indicates that the compiler should enforce conformance. Alternatively, you can continue to write code using the non-standard ANSI extensions provided by the compiler.



## 5.3 DEVICE-RELATED FEATURES

MPLAB XC8 has several features which relate directly to the 8-bit PIC architectures and instruction sets. These are detailed in the following sections.

### 5.3.1 Device Support

MPLAB XC8 C Compiler aims to support all 8-bit PIC devices. However, new devices in these families are frequently released. There are several ways you can check whether the compiler you are using supports a particular device.

From the command line, run the compiler you wish to use and pass it the option `--CHIPINFO` (See [Section 4.8.19 “--CHIPINFO: Display List of Supported Devices”](#)). A list of all devices will be printed.

If you use the `-V` option in addition to the `--CHIPINFO` option, more detailed information may be shown about each device.

You can also see the supported devices in your favorite web browser. Open the files `pic_chipinfo.html` for a list of all supported baseline or mid-range device, or `pic18_chipinfo.html` for all PIC18 devices. Both these files are located in the DOCS directory under your compiler's installation directory.

### 5.3.2 Instruction Set Support

The compiler support all instruction sets for PIC10/12/16 devices as well as the standard (legacy) PIC18 instruction set. The extended instruction mode available on some PIC18 devices is not currently supported. Ensure you set the Configuration bits to use the PIC18 legacy instruction mode when appropriate.

### 5.3.3 Device Header Files

There is one header file that is typically included into each C source file you write. The file is `<xc.h>` and is a generic header file that will include other device- and architecture-specific header files when you build your project.

Inclusion of this file will allow access to SFRs via special variables, as well as macros which allow special memory access or inclusion of special instructions, like `CLRWDT`.

Legacy projects can continue to use the `<htc.h>` header file.

Do not include chip-specific header files in your code as this will reduce portability, and these headers do not contain all the required definitions for successful compilation of your code.

The header files shipped with the compiler are specific to that compiler version. Future compiler versions can ship with modified header files. If you copy compiler header files into your project, particularly if you modify these files, be aware that they might not be compatible with future versions of the compiler.

For information about assembly include files (`.inc`), see [Section 5.12.3.2 “Accessing Registers from Assembly Code”](#).

## 5.3.4 Stacks

Stacks are used for two different purposes by programs running on 8-bit devices: one stack is for storing function return addresses, and one or two other stacks are used for data allocation.

### 5.3.4.1 FUNCTION RETURN ADDRESS STACK

The 8-bit PIC devices use what is referred to in this user's guide as a hardware stack. This stack is limited in depth and cannot be manipulated directly. It is only used for function return addresses and cannot be used for program data.

You must ensure that the maximum hardware stack depth is not exceeded; otherwise, code can fail. Nesting function calls too deeply will overflow the stack. It is important to take into account implicitly called library functions and interrupts, which also use levels of the stack. The compiler can be made to manage stack usage for some devices using the `stackcall` suboption to the `--RUNTIME` compiler option, see [Section 4.8.54 "--RUNTIME: Specify Runtime Environment"](#). This enables an alternate means of calling functions to prevent stack overflow.

A call graph is provided by the code generator in the assembler list file, see [Section 6.4.6 "Call Graph"](#). This will indicate the stack levels at each function call and can be used as a guide to stack depth. The code generator can also produce warnings if the maximum stack depth is exceeded.

The warnings and call graphs are *guides* to stack usage. Optimizations and the use of interrupts can decrease or increase the program's stack depth over that determined by the compiler.

### 5.3.4.2 DATA STACKS

The compiler can implement two types of data stack: a compiled stack and a software stack. Both these stacks are for storing stack-based variables, such as a function's auto, parameter, and temporary variables.

Either one or both of these types of stacks may be used by a program. Compiler options, specifiers, and how the functions are called will dictate which stacks are used. See [Section 5.5.2.2 "Auto Variable Allocation and access"](#), for more information on how the compiler allocates a function's stack-based objects.

A compiled stack is a static allocation of memory for stack-based objects that can be built up in multiple data banks. See [Section 5.5.2.2.1 "Compiled Stack Operation"](#) for information about how objects are allocated to this stack. Objects in the stack are in fixed locations and can be accessed using an identifier (hence it is a static allocation). Thus, there is no stack pointer. The size of the compiled stack is known at compile time, and so available space can be confirmed by the compiler. The compiled stack is allocated to psects that use the base name `cstack`; for example, `cstackCOMMON`, `cstackBANK0`. See [Section 5.15.2 "Compiler-Generated Psects"](#) for more information on the naming convention for compiler-generated psects.

By contrast, the software stack has a size that is dynamic and varies as the program is executed. The maximum size of the stack is not exactly known at compile time and the compiler typically reserves as much space as possible for the stack to grow during program execution. The stack is always allocated a single memory range, which may cross bank boundaries, but within this range it may be segregated into one area for main-line code and an area for each interrupt routine, if required. A stack pointer is used to indicate the current position in the stack. This pointer is permanently allocated to FSR1.

A psect is used as a placeholder to reserve the memory used by the stack. This psect is called `stack`.

## 5.3.5 Configuration Bit Access

The PIC devices have several locations which contain the Configuration bits or fuses. These bits specify fundamental device operation, such as the oscillator mode, watchdog timer, programming mode and code protection. Failure to correctly set these bits can result in code failure, or a non-running device.

These bits can be set using a configuration pragma. The pragma has the following forms.

```
#pragma config setting = state|value
#pragma config register = value
```

where *setting* is a configuration setting descriptor, e.g., WDT, and *state* is a textual description of the desired state, e.g., OFF. The *value* field is a numerical value that can be used in preference to a descriptor. Numerical values can only be specified in decimal or in hexadecimal, the latter radix indicated by the usual 0x prefix. Values must never be specified in binary (i.e., using the 0b prefix).

Consider the following examples.

```
#pragma config WDT = ON          // turn on watchdog timer
#pragma config WDTPS = 0x1A     // specify the timer postscale value
```

One pragma can be used to program several settings by separating each setting-value pair with a comma. For example, the above could be specified with one pragma, as in the following.

```
#pragma config WDT=ON, WDTPS = 0x1A
```

The setting-value pairs can also be quoted to ensure that the preprocessor does not perform substitution of these tokens, for example:

```
#pragma config "BOREN=OFF"
```

Without the quotes and with the preprocessor macro OFF defined, for example, substitution within the pragma would take place. You should never assume that the OFF and ON tokens used in configuration macros equate to 0 and 1, respectively, as that is often not the case.

Rather than specify individual settings, the entire register can be programmed with one numerical value, for example:

```
#pragma config CONFIG1L = 0x8F
```

The upper and lower half of each register must be programmed separately.

The settings and values associated with each device can be determined from an HTML guide. Open the `pic_chipinfo.html` file (or the `pic18_chipinfo.html` file) that is located in the DOCS directory of your compiler installation. Click the link to your target device, and the page will show you the settings and values that are appropriate with this pragma. Review your device data sheet for more information.

If you are using MPLAB X IDE, take advantage of its built-in tools to generate the required pragmas, so that you can copy and paste them into your source code.

## 5.3.5.1 CONFIGURATION BIT LEGACY SUPPORT

You can continue to use the configuration macros for legacy projects, but you should use the pragma for new projects.

The compiler supports the `__CONFIG` and `__PROG_CONFIG` macros, which allow configuration bit symbols or a Configuration Word value, respectively, to be specified, for example:

```
#include <xc.h>
__CONFIG(WDTDIS & HS & UNPROTECT);
```

For PIC10/12/16 devices that have more than one Configuration Word, each subsequent invocation of `__CONFIG()` will modify the next Configuration Word in sequence. When using the legacy macros for these devices, the order of the macros must match the order of the Configuration Words. Typically this might look like:

```
#include <xc.h>
__CONFIG(WDTDIS & XT & UNPROTECT); // Program config. word 1
__CONFIG(FCMEN);
```

The `__CONFIG` macro used for PIC18 devices takes an additional argument being the number of the Configuration Word location. For example:

```
__CONFIG(2, BW8 & PWRTDIS & WDTPS1 & WDTEN); // specify symbols
```

If you want to use a literal value to program the entire Configuration Word, you must use the `__PROG_CONFIG` macro. For PIC10/12/16 devices, that might appear as follows:

```
__PROG_CONFIG(0xFFFA);
```

and with PIC18 devices, you must again specify the word being programmed, as in the following:

```
__PROG_CONFIG(1, 0xFE57); // specify a literal constant value
```

You cannot use the setting symbols in the `__PROG_CONFIG` macro, nor can you use a literal value in the `__CONFIG` macro.

The configuration locations do not need to be programmed in order, except as noted above for multi-word PIC10/12/16 devices using the legacy macros.

To use the legacy macros, ensure you include `<xc.h>` in your source file. Symbols for the macros can be found in the `.cfgmap` files contained in the `dat/cfgmap` directory of your compiler installation.

## 5.3.5.2 CONFIGURATION CONSIDERATIONS

Neither the `config` pragma nor the `__CONFIG` macro produce executable code. They should both be placed outside function definitions so as not to interfere with the operation of the function's code.

MPLAB X IDE does not allow the Configuration bits to be adjusted. They must be specified in your source code using the pragma (or legacy macro).

All the bits in the Configuration Words should be programmed to prevent erratic program behavior. Do not leave them in their default/unprogrammed state. Not all Configuration bits have a default state of logic high; some have a logic low default state. Consult your device data sheet for more information.

## 5.3.6 Using SFRs From C Code

The Special Function Registers (SFRs) are registers which control aspects of the MCU operation or that of peripheral modules on the device. Most of these registers are memory mapped, which means that they appear at, and can be accessed using, specific addresses in the device's data memory space. Individual bits within some registers control independent features. Some registers are read-only; some are write-only. See your device data sheet for more information.

Memory-mapped SFRs are accessed by special C variables that are placed at the address of the register. (Variables that are placed at specific addresses are called *absolute variables* and are described in [Section 5.5.4 “Absolute Variables”](#).) These variables can be accessed like any ordinary C variable so that no special syntax is required to access SFRs.

The SFR variables are predefined in header files and are accessible once you have included the `<xc.h>` header file (see [Section 5.3.3 “Device Header Files”](#)) into your source code. Both `bit` variables and structures with bit-fields are defined, so you can use either of them in your source code to access bits within a register.

The names given to the C variables that map over registers and bits within those registers are based on the names specified in the device data sheet. However, as there can be duplication of some bit names within registers, there can be differences in the nomenclature.

The names of the structures that hold the bit-fields will typically be those of the corresponding register followed by `bits`. For example, the following shows code that includes the generic header file, clears PORTA as a whole, sets bit 0 of PORTA using a bit variable and sets bit 2 of PORTA using the structure/bit-field definitions.

```
#include <xc.h>
void main(void)
{
    PORTA = 0x00;
    RA0 = 1;
    PORTAbits.RA2 = 1;
}
```

To confirm the names that are relevant for the device you are using, check the device-specific header file that `<xc.h>` will include for the definitions of each variable. These files will be located in the `include` directory of the compiler and will have a name that represents the device. There is a one-to-one correlation between device and header file name that will be included by `<xc.h>`, e.g., when compiling for a PIC16LF1826 device, `<xc.h>` will include the header file `<pic16lf1826.h>`. Remember that you do not need to include this chip-specific file into your source code; it is automatically included by `<xc.h>`.

Care should be taken when accessing some SFRs from C code or from assembly in-line with C code. Some registers are used by the compiler to hold intermediate values of calculations, and writing to these registers directly can result in code failure. The compiler does not detect when SFRs have changed as a result of C or assembly code that writes to them directly. The list of registers used by the compiler and further information can be found in [Section 5.7 “Register Usage”](#).

SFRs associated with peripherals are not used by the compiler to hold intermediate results and can be changed as you require. Always ensure that you confirm the operation of peripheral modules from the device data sheet.

## 5.3.6.1 SPECIAL BASELINE/MID-RANGE REGISTER ISSUES

Some SFRs are not memory mapped, do not have a corresponding variable defined in the device specific header file, and cannot be directly accessed from C code.

For example, the W register is not memory mapped on baseline devices. Some devices use OPTION and TRIS registers, that are only accessible via special instructions and that are also not memory mapped. See [Section 5.3.10 “Baseline PIC MCU Special Instructions”](#) on how these registers are accessed by the compiler.

## 5.3.6.2 SPECIAL PIC18 REGISTER ISSUES

Some of the SFRs associated with the PIC18 can be grouped to form multi-byte values, e.g., the TMRxH and TMRxL register combined form a 16-bit timer count value. Depending on the device and mode of operation, there can be hardware requirements to read these registers in certain ways, e.g., often the TMRxL register must be read before trying to read the TMRxH register to obtain a valid 16-bit result.

Although it is possible to define a word-sized C variable to map over such registers, e.g., an `int` variable TMRx that maps over both TMRxL and TMRxH, the order in which the compiler would read the bytes of such an object will vary from expression to expression. Some expressions require that the Most Significant Byte (MSB) is read first; others start with the Least Significant Byte (LSB) first.

It is recommended that the existing SFR definitions in the chip header files be used. Each byte of the SFR should be accessed directly, and in the required order, as dictated by the device data sheet. This results in a much higher degree of portability.

The following code copies the two timer registers into a C `unsigned` variable `count` for subsequent use.

```
count = TMR0L;
count += TMR0H << 8;
```

Macros are also provided to perform reading and writing of the more common timer registers. See the macros `READTIMERx` and `WRITETIMERx` in [Appendix A. Library Functions](#). These guarantee the correct byte order is used.

## 5.3.7 ID Locations

The 8-bit PIC devices have locations outside the addressable memory area that can be used for storing program information, such as an ID number. The `config` pragma is also used to place data into these locations by using a special register name. The pragma is used as follows:

```
#pragma config IDLOCx = value
```

where `x` is the number (position) of the ID location, and `value` is the nibble or byte that is to be positioned into that ID location. The value can only be specified in decimal or in hexadecimal, the latter radix indicated by the usual `0x` prefix. Values must never be specified in binary (i.e., using the `0b` prefix). If `value` is larger than the maximum value allowable for each location on the target device, the value will be truncated and a warning message is issued. The size of each ID location varies from device to device. See your device data sheet for more information. For example:

```
#pragma config IDLOC0 = 1
#pragma config IDLOC1 = 4
```

will attempt fill the first two ID locations with 1 and 4. One pragma can be used to program several locations by separating each register-value pair with a comma. For example, the above could also be specified as shown below.

```
#pragma config IDLOC0 = 1, IDLOC1 = 4
```

The `config` pragma does not produce executable code and so should ideally be placed outside function definitions.

## 5.3.7.1 ID LOCATION LEGACY SUPPORT

The compiler also has legacy support for the `__IDLOC` macro. The macro is used in a manner similar to:

```
#include <xc.h>
__IDLOC(x);
```

where `x` is a list of hexadecimal digits, which are positioned into the ID locations. Do not use the usual `0x` hexadecimal radix specifier with these values. If an invalid character is encountered, the value 0 will be programmed into the corresponding location. Only the lower four bits of each ID location are programmed, so the following:

```
__IDLOC(15F0);
```

will attempt to fill ID locations with the hexadecimal values: 1, 5, F and 0.

To use this macro, ensure you include `<xc.h>` in your source file.

The `__IDLOC` macro does not produce executable code and so should ideally be placed outside function definitions.

Some devices permit programming up to seven bits within each ID location. The `__IDLOC()` macro is not suitable for such devices and the `__IDLOC7(a, b, c, d)` macro should be used instead. The parameters `a` to `d` must be constants which represent the values to be programmed. The values can be entered in either decimal or hexadecimal format, such as:

```
__IDLOC7(0x7f, 1, 70, 0x5a);
```

It is not appropriate to use the `__IDLOC7()` macro on a device that does not permit seven-bit programming of ID locations. The `__IDLOC7` macro does not produce executable code and so should ideally be placed outside function definitions.

## 5.3.8 Bit Instructions

Wherever possible, the MPLAB XC8 C Compiler will attempt to use bit instructions, even on non-bit integer values. For example, when using a bitwise operator and a mask to alter a bit within an integral type, the compiler will check the mask value to determine if a bit instruction can achieve the same functionality.

```
unsigned int foo;
foo |= 0x40;
```

will produce the instruction:

```
BSF _foo,6
```

To set or clear individual bits within integral type, the following macros could be used:

```
#define bitset(var, bitno) ((var) |= 1UL << (bitno))
#define bitclr(var, bitno) ((var) &= ~(1UL << (bitno)))
```

To perform the same operation on `foo` as above, the `bitset` macro could be employed as follows:

```
bitset(foo,6);
```

## 5.3.9 Multiplication

The PIC18 instruction set includes several 8-bit by 8-bit hardware multiply instructions, and these are used by the compiler in many situations. Non-PIC18 targets always use a library routine for multiplication operations.

There are three ways that 8x8-bit integer multiplication can be implemented by the compiler:

<b>Hardware Multiply Instructions (HMI)</b>	These assembly instructions are the most efficient method of multiplication, but they are only available on PIC18 devices.
<b>A bitwise iteration (8loop)</b>	Where dedicated multiplication instructions are not available, this implementation produces the smallest amount of code – a loop cycles through the bit pattern in the operands and constructs the result bit-by-bit. The speed of this implementation varies and is dependent on the operand values; however, this is typically the slowest method of performing multiplication.
<b>An unrolled bitwise sequence (8seq)</b>	This implementation performs a sequence of instructions that is identical to the bitwise iteration (above), but the loop is unrolled. The generated code is larger, but execution is faster than the loop version.

Multiplication of operands larger than 8 bits can be performed one of the following two ways:

<b>A bitwise iteration (xloop)</b>	This is the same algorithm used by 8-bit multiplication (above) but the loop runs over all (x) bits of the operands. Like its 8-bit counterpart, this implementation produces the smallest amount of code but is typically the slowest method of performing multiplication.
<b>A bitwise decomposition (bytdec)</b>	This is a decomposition of the multiplication into a summation of many 8-bit multiplications. The 8-bit multiplications can then be performed using any of the methods described above. This decomposition is highly advantageous for PIC18 devices, which can then use their hardware multiply instruction to perform such operations efficiently. For other devices, this method is still fast, but the code size can become impractical.

Multiplication of floating-point operands operates in a similar way – the integer mantissas can be multiplied using either a bitwise loop (xfploop) or by a bitwise decomposition.



The following tables indicate which of the multiplication methods are chosen by the compiler when performing multiplication of both integer and floating point operands. The method is dependent on the size of the operands, the type of optimizations enabled, and the target device.

Table 5-1 shows the methods chosen when speed optimizations are enabled, see Section 4.8.45 “[--OPT: Invoke Compiler Optimizations](#)”.

**TABLE 5-1: MULTIPLICATION WITH SPEED OPTIMIZATIONS**

Device	8-bit	16-bit	24-bit	32-bit	24-bit FP	32-bit FP
<b>PIC18</b>	HMI	bytdec+HMI	bytdec+HMI	bytdec+HMI	bytdec+HMI	bytdec+HMI
<b>Enhanced mid-range</b>	8seq	bytdec+8seq	bytdec+8seq	bytdec+8seq	bytdec+8seq	bytdec+8seq
<b>Mid-range/baseline</b>	8seq	16loop	24loop	32loop	24fploop	32fploop

Table 5-2 shows the method chosen when space optimizations are enabled or when no C-level optimizations are enabled.

**TABLE 5-2: MULTIPLICATION WITH NO OR SPACE OPTIMIZATIONS**

Device	8-bit	16-bit	24-bit	32-bit	24-bit FP	32-bit FP
<b>PIC18</b>	HMI	bytdec+HMI	24loop	32loop	24fploop	32fploop
<b>Enhanced mid-range</b>	8loop	bytdec+8loop	24loop	32loop	24fploop	32fploop
<b>Mid-range/baseline</b>	8loop	16loop	24loop	32loop	24fploop	32fploop

The source code for the multiplication routines (documented with the algorithms employed) is available in the SOURCES directory, located in the compiler’s installation directory. Look for files whose name has the form `Umulx.c`, where `x` is the size of the operation in bits.

If your device and optimization settings dictate the use of a bitwise multiplication loop you can sometimes arrange the multiplication operands in your C code to improve the operation’s speed. Where possible, ensure that the left operand to the multiplication is the smallest of the operands. For example, for the code:

```
x = 10;
y = 200;
result = x * y; // first multiply
result = y * x; // second multiply
```

the variable `result` will be assigned the same value in both statements, but the first multiplication expression will be performed faster than the second.

### 5.3.10 Baseline PIC MCU Special Instructions

The Baseline devices have some registers which are not in the normal SFR space and cannot be accessed using an ordinary file instruction. These are the OPTION and TRIS registers.

Both registers are write-only and cannot be used in expression that read their value. They can only be accessed using special instructions which the compiler will use automatically.

The definition of the variables that map to these registers make use of the `control` qualifier. This qualifier informs the compiler that the registers are outside of the normal address space and that a different access method is required. You should not use this qualifiers for any other registers.

When you write to either of these SFR variables, the compiler will use the appropriate instruction to load the value. So, for example, to load the TRIS register, the following code:

```
TRIS = 0xFF;
```

can be encoded by the compiler as:

```
MOVLW 0ffh  
TRIS
```

Those PIC devices which have more than one output port can have definitions for objects: `TRISA`, `TRISB` and `TRISC`, depending on the exact number of ports available. These objects are used in the same manner as described above.

Any register that uses the `control` qualifier must be accessed as a full byte. Do not attempt to access bits within the register. Copy the register to a temporary variable if required.

### 5.3.11 Oscillator Calibration Constants

Some Baseline and Mid-range devices come with an oscillator calibration constant which is pre-programmed into the device's program memory. This constant can be read from program memory and written to the OSCCAL register to calibrate the internal RC oscillator.

On some Baseline PIC devices, the calibration constant is stored as a `MOVLW` instruction at the top of program memory, e.g., the PIC10F509 device. On Reset, the program counter is made to point to this instruction and it is executed first before the program counter wraps around to 0x0000, which is the effective Reset vector for the device. The default runtime startup routine (see [Section 5.10.1 "Runtime Startup Code"](#)) will automatically include code to load the OSCCAL register with the value contained in the W register after Reset on such devices. No other code is required.

For other chips, such as PIC12F629 device, the oscillator constant is also stored at the top of program memory, but as a `RETLW` instruction. The compiler's startup code will automatically generate code to retrieve this value and perform the configuration.

At runtime, the calibration value stored as a `RETLW` instruction can be read using the 'function' `__osccal_val()`, as a label is assigned the `RETLW` instruction address. A prototype for the function is provided in `<xc.h>`. For example:

```
calVal = __osccal_val();
```

Loading of the calibration value can be turned off via the `osccal` suboption to the `--RUNTIME` option (see [Section 4.8.54 "--RUNTIME: Specify Runtime Environment"](#)).

At runtime, this calibration value can be read using the macro `_READ_OSCCAL_DATA()`. To be able to use this macro, make sure that `<xc.h>` is included into the relevant modules of your program. This macro returns the calibration constant which can then be stored into the OSCCAL register, as follows:

```
OSCCAL = _READ_OSCCAL_DATA();
```

**Note:** The location that stores the calibration constant is never code protected and will be lost if you reprogram the device. Thus, if you are using a windowed or Flash device, the calibration constant must be saved from the last ROM location before it is erased. The constant must then be reprogrammed at the same location along with the new program and data. If you are using an in-circuit emulator (ICE), the location used by the calibration `RETLW` instruction cannot be programmed. Calling the `__READ_OSCCAL_DATA()` macro will not work and will almost certainly not return correctly. If you wish to test code that includes this macro on an ICE, you will have to program a `RETLW` instruction at the appropriate location in program memory. Remember to remove this instruction when programming the actual part so you do not destroy the calibration value.

### 5.3.12 MPLAB REAL ICE In-Circuit Emulator Support

The compiler supports log and trace functions (instrumented trace) when using a Microchip MPLAB REAL ICE In-Circuit Emulator. See the emulator's documentation for more information on the instrumented trace features.

Only native trace is currently supported by the compiler. Not all devices support instrumented trace.

The log and trace macro calls need to be either added by hand to your source code or inserted by right-clicking on the appropriate location in MPLAB X IDE editor, as described by the emulator documentation. The `<xc.h>` header must be included in any modules that will use these macros. The macros have the following form.

```
__TRACE(id);  
__LOG(id, expression);
```

MPLAB X IDE will automatically substitute an appropriate value for `id` when you compile; however, you can specify these by hand if required. The trace `id` should be a constant in the range of 0x40 to 0x7F, and the log `id` is a constant in the range of 0x0 to 0x7F. Each macro should be given a unique number so that it can be properly identified. The same valid number can be used for both trace and log macros.

Macros should be inserted in the C source code at the desired locations, taking care that braces will ensure the correct program flow. They will trigger information to be sent to the debugger and IDE when they are executed, recording that execution reached that location in the program. The log `expression` can be any integer or 32-bit floating-point expression whose value will also be recorded. Typically, this expression is simply a variable name so the variable's contents are logged.

Adding trace and log macros will increase the size of your code as they contribute to the program image that is downloaded to the device.

Here is an example of these macros that you might add.

```
#include <xc.h>  
  
inpStatus = readUser();  
if(inpStatus == 0) {  
    __TRACE(id);  
    recovery();  
}  
__LOG(id, inpStatus);
```

## 5.3.13 Function profiling

The compiler can generate function registration code for the MPLAB REAL ICE In-Circuit Emulator to provide function profiling. The `flp` suboption to the `--RUNTIME` option (see [Section 4.8.54 “--RUNTIME: Specify Runtime Environment”](#)) enables this feature. To obtain profiling results, you must also use a Power Monitor Board and MPLAB X IDE and power monitor plugin that support code profiling for the MPLAB XC8 C Compiler.

When enabled, the compiler inserts assembly code into the prologue and epilogue of each function. This code communicates runtime information to the debugger to signal when a function is being entered and when it exits. This information, along with further measurements made by a Microchip Power Monitor Board, can determine how much energy each function is using. This feature is transparent, but note the following points when profiling is enabled:

- The program will increase in size and run slower due to the profiling code
- One extra level of hardware stack is used
- Some additional RAM memory is consumed
- Inlining of functions will not take place for any profiled function

If a function cannot be profiled (due to hardware stack constraints) but is qualified `inline`, the compiler might inline the function. See [Section 5.8.1.2 “Inline Specifier”](#) for more information on inlining functions.

## 5.4 SUPPORTED DATA TYPES AND VARIABLES

### 5.4.1 Identifiers

A C variable identifier (the following is also true for function identifiers) is a sequence of letters and digits, where the underscore character “\_” counts as a letter. Identifiers cannot start with a digit. Although they can start with an underscore, such identifiers are reserved for the compiler’s use and should not be defined by your programs. Such is not the case for assembly domain identifiers, which often begin with an underscore, see [Section 5.12.3.1 “Equivalent Assembly Symbols”](#).

Identifiers are case sensitive, so `main` is different to `Main`.

Not every character is significant in an identifier. The maximum number of significant characters can be set using an option, see [Section 4.8.8 “-N: Identifier Length”](#). If two identifiers differ only after the maximum number of significant characters, then the compiler will consider them to be the same symbol.

### 5.4.2 Integer Data Types

The MPLAB XC8 compiler supports integer data types with 1, 2, 3 and 4 byte sizes as well as a single bit type. [Table 5-3](#) shows the data types and their corresponding size and arithmetic type. The default type for each type is underlined.

**TABLE 5-3: INTEGER DATA TYPES**

Type	Size (bits)	Arithmetic Type
<code>bit</code>	1	Unsigned integer
<code>signed char</code>	8	Signed integer
<code>unsigned char</code>	8	Unsigned integer
<code>signed short</code>	16	Signed integer
<code>unsigned short</code>	16	Unsigned integer
<code>signed int</code>	16	Signed integer
<code>unsigned int</code>	16	Unsigned integer
<code>signed short long</code>	24	Signed integer
<code>unsigned short long</code>	24	Unsigned integer
<code>signed long</code>	32	Signed integer
<code>unsigned long</code>	32	Unsigned integer
<code>signed long long</code>	32	Signed integer
<code>unsigned long long</code>	32	Unsigned integer

The `bit` and `short long` types are non-standard types available in this implementation. The `long long` types are C99 Standard types, but this implementation limits their size to only 32 bits.

All integer values are represented in little endian format with the Least Significant Byte (LSB) at the lower address.

If no signedness is specified in the type, then the type will be `signed` except for the `char` types which are always `unsigned`. The `bit` type is always unsigned and the concept of a signed bit is meaningless.

Signed values are stored as a two’s complement integer value.

The range of values capable of being held by these types is summarized in [Table 5-4](#). The symbols in this table are preprocessor macros which are available after including `<limits.h>` in your source code.

As the size of data types are not fully specified by the ANSI Standard, these macros allow for more portable code which can check the limits of the range of values held by the type on this implementation.

The macros associated with the `short long` type are non-standard macros available in this implementation; those associated with the `long long` types are defined by the C99 Standard.

**TABLE 5-4: RANGES OF INTEGER TYPE VALUES**

Symbol	Meaning	Value
CHAR_BIT	bits per char	8
CHAR_MAX	max. value of a char	127
CHAR_MIN	min. value of a char	-128
SCHAR_MAX	max. value of a signed char	127
SCHAR_MIN	min. value of a signed char	-128
UCHAR_MAX	max. value of an unsigned char	255
SHRT_MAX	max. value of a short	32767
SHRT_MIN	min. value of a short	-32768
USHRT_MAX	max. value of an unsigned short	65535
INT_MAX	max. value of an int	32767
INT_MIN	min. value of a int	-32768
UINT_MAX	max. value of an unsigned int	65535
SHRTLONG_MAX	max. value of a short long	8388607
SHRTLONG_MIN	min. value of a short long	-8388608
USHRTLONG_MAX	max. value of an unsigned short long	16777215
LONG_MAX	max. value of a long	2147483647
LONG_MIN	min. value of a long	-2147483648
ULONG_MAX	max. value of an unsigned long	4294967295
LLONG_MAX	max. value of a long long	2147483647
LLONG_MIN	min. value of a long long	-2147483648
ULLONG_MAX	max. value of an unsigned long long	4294967295

Macros are also available in `<stdint.h>` which define values associated with fixed-width types.

When specifying a signed or unsigned short int, short long int, long int or long long int type, the keyword `int` can be omitted. Thus a variable declared as `short` will contain a signed short int and a variable declared as `unsigned short` will contain an unsigned short int.

It is a common misconception that the C `char` types are intended purely for ASCII character manipulation. However, the C language makes no guarantee that the default character representation is even ASCII. (This implementation does use ASCII as the character representation.)

The `char` types are the smallest of the multi-bit integer sizes, and behave in all respects like integers. The reason for the name “char” is historical and does not mean that `char` can only be used to represent characters. It is possible to freely mix `char` values with values of other types in C expressions. With the MPLAB XC8 C Compiler, the `char` types are used for a number of purposes – as 8-bit integers, as storage for ASCII characters, and for access to I/O locations.

## 5.4.2.1 BIT DATA TYPES AND VARIABLES

The MPLAB XC8 C Compiler supports `bit` integral types which can hold the values 0 or 1. Single `bit` variables can be declared using the keyword `bit` (or `__bit`), for example:

```
bit init_flag;
```

These variables cannot be `auto` or parameters to a function, but can be qualified `static`, allowing them to be defined locally within a function. For example:

```
int func(void) {
    static bit flame_on;
    // ...
}
```

A function can return a `bit` object by using the `bit` keyword in the function's prototype in the usual way. The 1 or 0 value will be returned in the carry flag in the STATUS register.

The `bit` variables behave in most respects like normal `unsigned char` variables, but they can only contain the values 0 and 1, and therefore provide a convenient and efficient method of storing flags. Eight `bit` objects are packed into each byte of memory storage, so they don't consume large amounts of internal RAM.

Operations on `bit` objects are performed using the single bit instructions (`bsf` and `bcf`) wherever possible, thus the generated code to access `bit` objects is very efficient.

It is not possible to declare a pointer to `bit` types or assign the address of a `bit` object to any pointer. Nor is it possible to statically initialize `bit` variables so they must be assigned any non-zero starting value (i.e., 1) in the code itself. `Bit` objects will be cleared on startup, unless the bit is qualified `persistent`.

When assigning a larger integral type to a `bit` variable, only the LSb is used. For example, if the `bit` variable `bitvar` was assigned as in the following:

```
int data = 0x54;
bit bitvar;
bitvar = data;
```

it will be cleared by the assignment since the LSb of `data` is zero. This sets the `bit` type apart from the C99 Standard `__Bool`, which is a boolean type, not a 1-bit wide integer. The `__Bool` type is not supported on the MPLAB XC8 compiler. If you want to set a `bit` variable to be 0 or 1 depending on whether the larger integral type is zero (false) or non-zero (true), use the form:

```
bitvar = (data != 0);
```

The psects in which `bit` objects are allocated storage are declared using the `bit PSECT` directive flag, see [Section 6.2.9.3 "PSECT"](#). All addresses assigned to `bit` objects and psects will be bit addresses. For absolute `bit` variables (see [Section 5.5.4 "Absolute Variables"](#)), the address specified in code must be a bit address. Take care when comparing these addresses to byte addresses used by all other variables.

If the `xc8` flag `--STRICT` is used, the `bit` keyword becomes unavailable, but you can use the `__bit` keyword.

## 5.4.3 Floating-Point Data Types

The MPLAB XC8 compiler supports 24- and 32-bit floating-point types. Floating point is implemented using either a IEEE 754 32-bit format, or a truncated, 24-bit form of this. [Table 5-5](#) shows the data types and their corresponding size and arithmetic type.

**TABLE 5-5: FLOATING-POINT DATA TYPES**

Type	Size (bits)	Arithmetic Type
float	24 or 32	Real
double	24 or 32	Real
long double	same as double	Real

For both `float` and `double` values, the 24-bit format is the default. The options `--FLOAT=24` and `--DOUBLE=24` can also be used to specify this explicitly. The 32-bit format is used for `double` values if the `--DOUBLE=32` option is used and for `float` values if `--FLOAT=32` is used.

Variables can be declared using the `float` and `double` keywords, respectively, to hold values of these types. Floating-point types are always signed and the `unsigned` keyword is illegal when specifying a floating-point type. Types declared as `long double` will use the same format as types declared as `double`. All floating-point values are represented in little endian format with the LSB at the lower address.

The 32-bit floating-point type supports "relaxed" floating-point semantics when compared to the full IEEE implementation. This means the following rules are observed.

Tiny (sub-normal) arguments to floating-point routines are interpreted as zeros. There are no representable floating-point values possible between  $-1.17549435E-38$  and  $1.17549435E-38$ , except for 0.0. This range is called the denormal range. Sub-normal results of routines are flushed to zero. There are no negative 0 results produced.

Not-a-number (NaN) arguments to routines are interpreted as infinities. NaN results are never created in addition, subtraction, multiplication, or division routines where a NaN would be normally expected—an infinity of the proper sign is created instead. The square root of a negative number will return the "distinguished" NaN (default NaN used for error return).

Infinities are legal arguments for all operations and behave as the largest representable number with that sign. For example, `+inf + -inf` yields the value 0.

The format for both floating-point types is described in [Table 5-6](#), where:

- *Sign* is the sign bit, which indicates if the number is positive or negative
- The *Biased Exponent* is 8 bits wide and is stored as excess 127 (i.e., an exponent of 0 is stored as 127).
- *Mantissa* is the mantissa, which is to the right of the radix point. There is an implied bit to the left of the radix point which is always 1 except for a zero value, where the implied bit is zero. A zero value is indicated by a zero exponent.

The value of this number is  $(-1)^{\text{sign}} \times 2^{(\text{exponent}-127)} \times 1.\text{mantissa}$ .

**TABLE 5-6: FLOATING-POINT FORMATS**

Format	Sign	Biased Exponent	Mantissa
IEEE 754 32-bit	x	xxxx xxxx	xxx xxxx xxxx xxxx xxxx xxxx
modified IEEE 754 24-bit	x	xxxx xxxx	xxx xxxx xxxx xxxx



Here are some examples of the IEEE 754 32-bit formats shown in [Table 5-7](#). Note that the Most Significant Bit (MSb) of the mantissa column (i.e., the bit to the left of the radix point) is the implied bit, which is assumed to be 1 unless the exponent is zero.

**TABLE 5-7: FLOATING-POINT FORMAT EXAMPLE IEEE 754**

Format	Value	Biased Exponent	1.mantissa	Decimal
32-bit	7DA6B69Bh	11111011b	1.0100110101101101 0011011b	2.77000e+37
		(251)	(1.302447676659)	—
24-bit	42123Ah	10000100b	1.001001000111010b	36.557
		(132)	(1.142395019531)	—

Use the following process to manually calculate the 32-bit example in [Table 5-7](#).

The sign bit is zero; the biased exponent is 251, so the exponent is 251-127=124. Take the binary number to the right of the decimal point in the mantissa. Convert this to decimal and divide it by  $2^{23}$  where 23 is the size of the mantissa, to give 0.302447676659. Add 1 to this fraction. The floating-point number is then given by:

$$-1^0 \times 2^{124} \times 1.302447676659$$

which is approximately equal to:

$$2.77000e+37$$

Binary floating-point values are sometimes misunderstood. It is important to remember that not every floating-point value can be represented by a finite sized floating-point number. The size of the exponent in the number dictates the range of values that the number can hold, and the size of the mantissa relates to the spacing of each value that can be represented exactly. Thus the 24-bit format allows for values with approximately the same range of values representable by the 32-bit format, but the values that can be exactly represented by this format are more widely spaced.

So, for example, if you are using a 24-bit wide floating-point type, it can exactly store the value 95000.0. However, the next highest number it can represent is 95002.0 and it is impossible to represent any value in between these two in such a type as it will be rounded. This implies that C code which compares floating-point values might not behave as expected. For example:

```
volatile float myFloat;
myFloat = 95002.0;
if(myFloat == 95001.0)    // value will be rounded
    PORTA++;             // this line will be executed!
```

in which the result of the `if()` expression will be true, even though it appears the two values being compared are different.

Compare this to a 32-bit floating-point type, which has a higher precision. It also can exactly store 95000.0 as a value. The next highest value which can be represented is (approximately) 95000.00781.

The characteristics of the floating-point formats are summarized in [Table 5-8](#). The symbols in this table are preprocessor macros that are available after including `<float.h>` in your source code.

Two sets of macros are available for `float` and `double` types, where `XXX` represents `FLT` and `DBL`, respectively. So, for example, `FLT_MAX` represents the maximum floating-point value of the `float` type. It can have two values depending on whether `float` is a 24 or 32 bit wide format. `DBL_MAX` represents the same values for the `double` type.

As the size and format of floating-point data types are not fully specified by the ANSI Standard, these macros allow for more portable code which can check the limits of the range of values held by the type on this implementation.

**TABLE 5-8: RANGES OF FLOATING-POINT TYPE VALUES**

Symbol	Meaning	24-bit Value	32-bit Value
XXX_RADIX	Radix of exponent representation	2	2
XXX_ROUNDSD	Rounding mode for addition	0	1
XXX_MIN_EXP	Min. $n$ such that $FLT\_RADIX^{n-1}$ is a normalized float value	-125	-125
XXX_MIN_10_EXP	Min. $n$ such that $10^n$ is a normalized float value	-37	-37
XXX_MAX_EXP	Max. $n$ such that $FLT\_RADIX^{n-1}$ is a normalized float value	128	128
XXX_MAX_10_EXP	Max. $n$ such that $10^n$ is a normalized float value	38	38
XXX_MANT_DIG	Number of FLT_RADIX mantissa digits	16	24
XXX_EPSILON	The smallest number which added to 1.0 does not yield 1.0	3.05176e-05	1.19209e-07

## 5.4.4 Structures and Unions

MPLAB XC8 C Compiler supports `struct` and `union` types. Structures and unions only differ in the memory offset applied to each member.

These types will be at least 1 byte wide. The members of structures and unions cannot be objects of type `bit`, but bit-fields are fully supported.

Structures and unions can be passed freely as function arguments and function return values. Pointers to structures and unions are fully supported.

### 5.4.4.1 STRUCTURE AND UNION QUALIFIERS

The compiler supports the use of type qualifiers on structures. When a qualifier is applied to a structure, all of its members will inherit this qualification. In the following example the structure is qualified `const`.

```
const struct {
    int number;
    int *ptr;
} record = { 0x55, &i };
```

In this case, the entire structure will be placed into the program space and each member will be read-only. Remember that all members are usually initialized if a structure is `const` as they cannot be initialized at runtime.

If the members of the structure were individually qualified `const`, but the structure was not, then the structure would be positioned into RAM, but each member would be read-only. Compare the following structure with the above.

```
struct {
    const int number;
    int * const ptr;
} record = { 0x55, &i };
```

## 5.4.4.2 BIT-FIELDS IN STRUCTURES

MPLAB XC8 C Compiler fully supports bit-fields in structures.

Bit-fields are always allocated within 8-bit words, even though it is usual to use the type `unsigned int` in the definition.

The first bit defined will be the LSb of the word in which it will be stored. When a bit-field is declared, it is allocated within the current 8-bit unit if it will fit; otherwise, a new byte is allocated within the structure. Bit-fields can never cross the boundary between 8-bit allocation units. For example, the declaration:

```
struct {
    unsigned    lo : 1;
    unsigned    dummy : 6;
    unsigned    hi : 1;
} foo;
```

will produce a structure occupying 1 byte. If `foo` was ultimately linked at address 0x10, the field `lo` will be bit 0 of address 0x10 and field `hi` will be bit 7 of address 0x10. The LSb of `dummy` will be bit 1 of address 0x10, and the MSb of `dummy` will be bit 6 of address 0x10.

**Note:** Accessing bit-fields larger than a single bit can be very inefficient. If code size and execution speed are critical, consider using a `char` type or a `char` structure member, instead. Be aware that some SFRs are defined as bit-fields. Most are single bits, but some can be multi-bit objects.

Unnamed bit-fields can be declared to pad out unused space between active bits in control registers. For example, if `dummy` is never referenced, the structure above could have been declared as:

```
struct {
    unsigned    lo : 1;
    unsigned    : 6;
    unsigned    hi : 1;
} foo;
```

A structure with bit-fields can be initialized by supplying a *comma*-separated list of initial values for each field. For example:

```
struct {
    unsigned    lo : 1;
    unsigned    mid : 6;
    unsigned    hi : 1;
} foo = {1, 8, 0};
```

Structures with unnamed bit-fields can be initialized. No initial value should be supplied for the unnamed members, for example:

```
struct {
    unsigned    lo : 1;
    unsigned    : 6;
    unsigned    hi : 1;
} foo = {1, 0};
```

will initialize the members `lo` and `hi` correctly.

A bit-field that has a size of 0 is a special case. The Standard indicates that no further bit-field is to be packed into the allocation unit in which the previous bit-field, if any, was placed.

## 5.4.4.3 ANONYMOUS STRUCTURES AND UNIONS

The MPLAB XC8 compiler supports anonymous structures and unions. These are constructs with no identifier and whose members can be accessed without referencing the identifier of the construct. Anonymous structures and unions must be placed inside other structures or unions. For example:

```
struct {
    union {
        int x;
        double y;
    };
} aaa;

void main(void)
{
    aaa.x = 99;
    // ...}
```

Here, the union is not named and its members accessed as if they are part of the structure.

Objects defined with anonymous structures or unions cannot be initialized.

Note that anonymous structures and unions are not part of the ISO C90 C Standard. Their use limits the portability of any code, and they are not recommended

## 5.4.5 Pointer Types

There are two basic pointer types supported by the MPLAB XC8 C Compiler: data pointers and function pointers. Data pointers hold the addresses of variables which can be indirectly read, and possibly indirectly written, by the program. Function pointers hold the address of an executable function which can be called indirectly via the pointer.

To conserve memory requirements and reduce execution time, pointers are made different sizes and formats. The MPLAB XC8 C Compiler uses sophisticated algorithms to track the assignment of addresses to all pointers, and, as a result, non-standard qualifiers are not required when defining pointer variables. The standard qualifiers `const` and `volatile` can still be used and have their usual meaning. Despite this, the size of each pointer is optimal for its intended usage in the program.

### 5.4.5.1 COMBINING TYPE QUALIFIERS AND POINTERS

It is helpful to first review the ANSI C standard conventions for definitions of pointer types.

Pointers can be qualified like any other C object, but care must be taken when doing so as there are two quantities associated with pointers. The first is the actual pointer itself, which is treated like any ordinary C variable and has memory reserved for it. The second is the target, or targets, that the pointer references, or to which the pointer points. The general form of a pointer definition looks like the following:

```
target_type_&_qualifiers * pointer's_qualifiers pointer's_name;
```

Any qualifiers to the right of the `*` (i.e., next to the pointer's name) relate to the pointer variable itself. The type and any qualifiers to the left of the `*` relate to the pointer's targets. This makes sense since it is also the `*` operator that dereferences a pointer, which allows you to get from the pointer variable to its current target.

Here are three examples of pointer definitions using the `volatile` qualifier. The fields in the definitions have been highlighted with spacing:

```
volatile int *      vip ;  
int             * volatile  ivp ;  
volatile int * volatile vivp ;
```

The first example is a pointer called `vip`. It contains the address of `int` objects that are qualified `volatile`. The pointer itself – the variable that holds the address – is *not* `volatile`; however, the objects that are accessed when the pointer is dereferenced are treated as being `volatile`. In other words, the target objects accessible via the pointer can be externally modified.

The second example is a pointer called `ivp` which also contains the address of `int` objects. In this example, the pointer itself is `volatile`, that is, the address the pointer contains can be externally modified; however, the objects that can be accessed when dereferencing the pointer are *not* `volatile`.

The last example is of a pointer called `vivp` which is itself qualified `volatile`, and which also holds the address of `volatile` objects.

Bear in mind that one pointer can be assigned the addresses of many objects; for example, a pointer that is a parameter to a function is assigned a new object address every time the function is called. The definition of the pointer must be valid for every target address assigned.

**Note:** Care must be taken when describing pointers. Is a “const pointer” a pointer that points to `const` objects, or a pointer that is `const` itself? You can talk about “pointers to `const`” and “const pointers” to help clarify the definition, but such terms cannot be universally understood.

## 5.4.5.2 DATA POINTERS

The MPLAB XC8 compiler monitors and records *all* assignments of addresses to each data pointer the program contains. This includes assignment of the addresses of objects to pointers; assignment of one pointer to another; initialization of pointers when they are defined; and takes into account when pointers are ordinary variables and function parameters, and when pointers are used to access basic objects, or structures or arrays.

The size and format of the address held by each pointer is based on this information. When more than one address is assigned to a pointer at different places in the code, a set of all possible targets the pointer can address is maintained. This information is specific to each pointer defined in the program, thus two pointers with the same C type can hold addresses of different sizes and formats due to the way the pointers were used in the program.

The compiler tracks the memory location of all targets, as well as the size of all targets to determine the size and scope of a pointer. The size of a target is important as well, particularly with arrays or structures. It must be possible to increment a pointer so it can access all the elements of an array, for example.

There are several pointer classifications used with the MPLAB XC8 C Compiler, such as those indicated below.

### **For baseline and mid-range devices:**

- 8-bit pointer capable of accessing common memory and two consecutive (even-odd) banks, e.g., banks 0 and 1, or banks 6 and 7, etc.
- 16-bit pointer capable of accessing the entire data memory space
- 8-bit pointer capable of accessing up to 256 bytes of program space data
- 16-bit pointer capable of accessing up to 64 Kbytes of program space data
- 16-bit mixed target space pointer capable of accessing the entire data space memory and up to 64 Kbytes of program space data

### **For PIC18 devices:**

- 8-bit pointer capable of accessing the access bank
- 16-bit pointer capable of accessing the entire data memory space
- 8-bit pointer capable of accessing up to 256 bytes of program space data
- 16-bit pointer capable of accessing up to 64 Kbytes of program space data
- 24-bit pointer capable of accessing the entire program space
- 16-bit mixed target space pointer capable of accessing the entire data space memory and up to 64 Kbytes of program space data
- 24-bit mixed target space pointer capable of accessing the entire data space memory and the entire program space

Each data pointer will be allocated one of the available classifications after preliminary scans of the source code. There is no mechanism by which the programmer can specify the style of pointer required (other than by the assignments to the pointer). The C code must convey the required information to the compiler.

Information about the pointers and their targets are shown in the pointer reference graph, which is described in [Section 6.4.5 "Pointer Reference Graph"](#). This graph is printed in the assembly list file, which is controlled by the option described in [Section 4.8.16 "--ASMLIST: Generate Assembler List Files"](#).

Consider the following mid-range device program in the early stages of development. It consists of the following code:

```
int i, j;

int getValue(const int * ip) {
    return *ip;
}

void main(void) {
    j = getValue(&i);
    // ... code that uses j
}
```

A pointer, `ip`, is a parameter to the function `getValue()`. The pointer target type uses the qualifier `const` because we do not want the pointer to be used to write to any objects whose addresses are passed to the function. The `const` qualification serves no other purpose and does not alter the format of the pointer variable.

If the compiler allocates the variable `i` (defined in `main()`) to bank 0 data memory, it will also be noted that the pointer `ip` (parameter to `getValue()`) only points to one object that resides in bank 0 of the data memory. In this case, the pointer, `ip`, is made an 8-bit wide data pointer. The generated code that dereferences `ip` in `getValue()` will be generated assuming that the address can only be to an object in bank 0.

As the program is developed, another variable, `x`, is defined and (unknown to the programmer) is allocated space in bank 2 data memory. The `main()` function now looks like:

```
int i, j; // allocated to bank 0 in this example
int x;    // allocated to bank 2 in this example

int getValue(const int * ip) {
    return *ip;
}

void main(void) {
    j = getValue(&i);
    // ... code that uses j
    j = getValue(&x);
    // ... code that uses j
}
```

The pointer, `ip`, now has targets that are in bank 0 and in bank 2. To be able to accommodate this situation, the pointer is made 16 bits wide, and the code used to dereference the pointer will change accordingly. This takes place without any modification to the source code.

One positive aspect of tracking pointer targets is less of a dependence on pointer qualifiers. The standard qualifiers `const` and `volatile` must still be used in pointer definitions to indicate a read-only or externally-modifiable target object, respectively. However, this is in strict accordance with the ANSI C standard. Non-standard qualifiers, like `near` and `bank2`, are not required to indicate pointer targets, have no effect, and should be avoided. Omitting these qualifiers will result in more portable and readable code, and reduce the chance of extraneous warnings being issued by the compiler.

## 5.4.5.2.1 Pointers to Both Memory Spaces

When a pointer is assigned the address of one or more objects that have been allocated memory in the data space, and also assigned the address of one or more `const` objects, the pointer is said to have targets with mixed memory spaces. Such pointers fall into one of the mixed target space pointer classifications, which are listed in [Section 5.4.5.2 “Data Pointers”](#), and the address will be encoded so that the target memory space can be determined at runtime. The encoding of these pointer types are as follows.

For the Baseline/Mid-range 16-bit mixed target space pointer, the MSb of the address (i.e., bit number 15) indicates the memory space that the address references. If this bit is set, it indicates that the address is of something in program memory; clear indicates an object in the data memory. The remainder of this address represents the full address in the indicated memory space.

For the PIC18 24-bit mixed target space pointer, bit number 21 indicates the memory space that the address references. If this bit is set, it indicates that the address is of an object residing in data memory; if it is clear, it indicates an object in the program memory. The remainder of this address represents the full address in the indicated memory space. Note that for efficiency reasons, the meaning of the memory space bit is the opposite to that for baseline and mid-range devices.

To extend the mid-range device example given in [Section 5.4.5.2 “Data Pointers”](#), the code is now developed further. The function `getValue()` is now called with the address of an object that resides in the program memory, as shown.

```
int i, j; // allocated to bank 0 in this example
int x;    // allocated to bank 2 in this example
const int type = 0x3456;

int getValue(const int * ip) {
    return *ip;
}

void main(void) {
    j = getValue(&i);
    // ... code that uses j
    j = getValue(&x);
    // ... code that uses j
    j = getValue(&type);
    // ... code that uses j
}
```

Again, the targets to the pointer, `ip`, are determined, and now the pointer is made of the class that can access both data and program memory. The generated code to dereference the pointer will be such that it can determine the required memory space from the address, and access either space accordingly. Again, this takes place without any change in the definition of the pointer.

If assembly code references a C pointer, the compiler will force that pointer to become a 16-bit mixed target space pointer, in the case of baseline or mid-range programs, or a 24-bit mixed target space pointer, for PIC18 programs. These pointer types have unrestricted access to all memory areas and will operate correctly, even if assignments (of a correctly formatted address) are made to the pointer in the assembly code.

## 5.4.5.3 FUNCTION POINTERS

The MPLAB XC8 compiler fully supports pointers to functions, which allows functions to be called indirectly. These are often used to call one of several function addresses stored in a user-defined C array, which acts like a lookup table.



For baseline and mid-range devices, function pointers are always one byte in size and hold an offset into a jump table that is output by the compiler. This jump table contains jumps to the destination functions.

For enhanced mid-range devices, function pointers are always 16-bits wide and can hold the full address of any function.

For PIC18 devices, function pointers are either 16 or 24 bits wide. The pointer size is purely based on the amount of program memory available on the target device.

As with data pointers, the target assigned to function pointers is tracked. This is an easier process to undertake compared to that associated with data pointers as all function instructions must reside in program memory. The pointer reference graph (described in [Section 6.4.5 “Pointer Reference Graph”](#)) will show function pointers, in addition to data pointers, as well as all their targets. The targets will be names of functions that could possibly be called via the pointer.

One notable runtime feature for baseline and mid-range devices is that a function pointer which contains null (the value 0) and is used to call a function indirectly will cause the code to become stuck in a loop which branches to itself. This endless loop can be used to detect this erroneous situation. Typically calling a function via a null function would result in the code crashing or some other unexpected behavior. The label to which the endless loop will jump is called `fpbase`.

#### 5.4.5.4 SPECIAL POINTER TARGETS

Pointers and integers are not interchangeable. Assigning an integer constant to a pointer will generate a warning to this effect. For example:

```
const char * cp = 0x123; // the compiler will flag this as bad code
```

There is no information in the integer constant, 0x123, relating to the type, size or memory location of the destination. There is a very good chance of code failure if pointers are assigned integer addresses and dereferenced, particularly for PIC devices that have more than one memory space. Is 0x123 an address in data memory or program memory? How big is the object found at address 0x123?

Always take the address of a C object when assigning an address to a pointer. If there is no C object defined at the destination address, then define or declare an object at this address which can be used for this purpose. Make sure the size of the object matches the range of the memory locations that are to be accessed by the pointer.

For example, a checksum for 1000 memory locations starting at address 0x900 in program memory is to be generated. A pointer is used to read this data. You can be tempted to write code such as:

```
const char * cp;
cp = 0x900; // what resides at 0x900???
```

and increment the pointer over the data.

However, a much better solution is this:

```
const char * cp;
const char inputData[1000] @ 0x900;
cp = &inputData;
// cp is incremented over inputData and used to read values there
```

In this case, the compiler can determine the size of the target and the memory space. The array size and type indicates the size of the pointer target, the `const` qualifier on the object (not the pointer) indicates the target is located in program memory space. Note that the `const` array does not need initial values to be specified in this instance, see [Section 5.4.7.1 “Const Type Qualifier”](#) and can reside over the top of other objects at these addresses.

If the pointer has to access objects in data memory, you need to define a different object to act as a dummy target. For example, if the checksum was to be calculated over 10 bytes starting at address 0x90 in data memory, the following code could be used.

```
const char * cp;
extern char inputData[10] @ 0x90;
cp = &inputData;
// cp is incremented over inputData and used to read values there
```

No memory is consumed by the `extern` declaration, and this can be mapped over the top of existing objects.

User-defined absolute objects will not be cleared by the runtime startup code and can be placed over the top of other absolute variables.

Take care when comparing (subtracting) pointers. For example:

```
if(cp1 == cp2)
    ; // take appropriate action
```

The ANSI C standard only allows pointer comparisons when the two pointer targets are the same object. One exception is that the address can extend to one element past the end of an array.

Comparisons of pointers to integer constants are even more risky, for example:

```
if(cp1 == 0x246)
    ; // take appropriate action
```

Never compare pointers with integer constants.

A null pointer is the one instance where a constant value can be assigned to a pointer and this is handled correctly by the compiler. A null pointer is numerically equal to 0 (zero), but this is a special case imposed by the ANSI C standard. Comparisons with the macro `NULL` are also allowed.

If null is the only value assigned to a pointer, the pointer will be made as small as possible.

## 5.4.6 Constant Types and Formats

A constant is used to represent an immediate value in the source code, as opposed to a variable that could hold the same value. For example 123 is a constant.

Like any value, a constant must have a C type. In addition to a constant's type, the actual value can be specified in one of several formats.

### 5.4.6.1 INTEGRAL CONSTANTS

The format of integral constants specifies their radix. MPLAB XC8 supports the ANSI standard radix specifiers, as well as ones which enables binary constants to be specified in C code.

The formats used to specify the radices are given in [Table 5-9](#). The letters used to specify binary or hexadecimal radices are case insensitive, as are the letters used to specify the hexadecimal digits.

**TABLE 5-9: RADIX FORMATS**

Radix	Format	Example
binary	0b <i>number</i> or 0B <i>number</i>	0b10011010
octal	0 <i>number</i>	0763
decimal	<i>number</i>	129
hexadecimal	0x <i>number</i> or 0X <i>number</i>	0x2F

Any integral constant will have a type of `int`, `long int` or `long long int`, so that the type can hold the value without overflow. Constants specified in octal or hexadecimal can also be assigned a type of `unsigned int`, `unsigned long int` or `unsigned long long int` if the signed counterparts are too small to hold the value.

The default types of constants can be changed by the addition of a suffix after the digits; e.g., `23U`, where `U` is the suffix. [Table 5-10](#) shows the possible combination of suffixes and the types that are considered when assigning a type. So, for example, if the suffix `l` is specified and the value is a decimal constant, the compiler will assign the type `long int`, if that type will hold the constant; otherwise, it will assigned `long long int`. If the constant was specified as an octal or hexadecimal constant, then `unsigned` types are also considered.

**TABLE 5-10: SUFFIXES AND ASSIGNED TYPES**

Suffix	Decimal	Octal or Hexadecimal
<code>u</code> or <code>U</code>	<code>unsigned int</code> <code>unsigned long int</code> <code>unsigned long long int</code>	<code>unsigned int</code> <code>unsigned long int</code> <code>unsigned long long int</code>
<code>l</code> or <code>L</code>	<code>long int</code> <code>long long int</code>	<code>long int</code> <code>unsigned long int</code> <code>long long int</code> <code>unsigned long long int</code>
<code>u</code> or <code>U</code> , and <code>l</code> or <code>L</code>	<code>unsigned long int</code> <code>unsigned long long int</code>	<code>unsigned long int</code> <code>unsigned long long int</code>
<code>ll</code> or <code>LL</code>	<code>long long int</code>	<code>long long int</code> <code>unsigned long long int</code>
<code>u</code> or <code>U</code> , and <code>ll</code> or <code>LL</code>	<code>unsigned long long int</code>	<code>unsigned long long int</code>

Here is an example of code that can fail because the default type assigned to a constant is not appropriate:

```
unsigned long int result;
unsigned char shifter;

void main(void)
{
    shifter = 20;
    result = 1 << shifter;
    // code that uses result
}
```

The constant 1 (one) will be assigned an `int` type, hence the result of the shift operation will be an `int`. Even though this result is assigned to the `long` variable, `result`, it can never become larger than the size of an `int`, regardless of how much the constant is shifted. In this case, the value 1 shifted left 20 bits will yield the result 0, not 0x100000.

The following uses a suffix to change the type of the constant, hence ensure the shift result has an `unsigned long` type.

```
result = 1UL << shifter;
```

## 5.4.6.2 FLOATING-POINT CONSTANT

Floating-point constants have `double` type unless suffixed by `f` or `F`, in which case it is a `float` constant. The suffixes `l` or `L` specify a `long double` type which is considered an identical type to `double` by MPLAB XC8.

## 5.4.6.3 CHARACTER AND STRING CONSTANTS

Character constants are enclosed by single quote characters, `'`, for example `'a'`. A character constant has `int` type, although this can be later optimized to a `char` type by the compiler.

To comply with the ANSI C standard, the compiler does not support the extended character set in characters or character arrays. Instead, they need to be escaped using the backslash character, as in the following example.

```
const char name[] = "Bj\370rk";
printf("%s's Resum\351", name);  \\ prints "Bjørk's Resumé"
```

Multi-byte character constants are not supported by this implementation.

String constants, or string literals, are enclosed by double quote characters `"`, for example `"hello world"`. The type of string constants is `const char *` and the characters that make up the string are stored in the program memory, as are all objects qualified `const`.

A common warning relates to assigning a string literal to a pointer that does not specify a `const` target, for example:

```
char * cp = "hello world\n";
```

The string characters cannot be modified, but this type of pointer allows writes to take place, hence the warning. To prevent yourself from trying to overwrite the string, qualify the pointer target as follows. See also [Section 5.4.5.1 "Combining Type Qualifiers and Pointers"](#).

```
const char * cp = "hello world\n";
```

Defining and initializing an array (i.e., not a pointer) with a string is an exception. For example:

```
char ca[] = "hello world\n";
```

will actually copy the string characters into the RAM array, rather than assign the address of the characters to a pointer, as in the previous examples. The string literal remains read-only, but the array is both readable and writable.

The MPLAB XC8 compiler will use the same storage location and label for strings that have identical character sequences, except where the strings are used to initialize an array residing in the data space. For example, in the code snippet

```
if(strncmp(scp, "hello", 6) == 0)
    fred = 0;
if(strcmp(scp, "world") == 0)
    fred--;
if(strcmp(scp, "hello world") == 0)
    fred++;
```

the characters in the string "world" and the last 6 characters of the string "hello world" (the last character is the null terminator character) would be represented by the same characters in memory. The string "hello" would not overlap with the same characters in the string "hello world" as they differ in terms of the placement of the null character.

Two adjacent string constants (i.e., two strings separated *only* by white space) are concatenated by the compiler. Thus:

```
const char * cp = "hello" "world";
```

will assign the pointer with the address of the string "hello world".

## 5.4.7 Standard Type Qualifiers

Type qualifiers provide information regarding how an object can be used. The MPLAB XC8 compiler supports the ANSI C qualifiers `const` and `volatile` and additional qualifiers which allow programs take advantage of the 8-bit PIC MCU architecture.

### 5.4.7.1 CONST TYPE QUALIFIER

The `const` type qualifier is used to tell the compiler that an object is read only and will not be modified. If any attempt is made to modify an object declared `const`, the compiler will issue a warning or error.

User-defined objects declared `const` are placed in a special psect linked into the program space. Objects qualified `const` can be absolute. The `@ address` construct is used to place the object at the specified address in program memory, as in the following example which places the object `tableDef` at address `0x100`.

```
const int tableDef[] @ 0x100 = { 0, 1, 2, 3, 4};
```

Usually a `const` object must be initialized when it is declared, as it cannot be assigned a value at any point at runtime. For example:

```
const int version = 3;
```

will define `version` as being a read-only `int` variable, holding the value 3. However, uninitialized `const` objects can be defined and are useful if you need to place an object in program memory over the top of other objects at a particular location. Usually uninitialized `const` objects will be defined as absolute, as in the following example.

```
const char checksumRange[0x100] @ 0x800;
```

will define `checksumRange` as an array of `0x100` characters located at address `0x800` in program memory. This definition will not place any data in the HEX file.

### 5.4.7.2 VOLATILE TYPE QUALIFIER

The `volatile` type qualifier is used to tell the compiler that an object cannot be guaranteed to retain its value between successive accesses. This prevents the optimizer from eliminating apparently redundant references to objects declared `volatile` because it can alter the behavior of the program to do so.

Any SFR which can be modified by hardware or which drives hardware is qualified as `volatile`, and any variables which can be modified by interrupt routines should use this qualifier as well. For example:

```
volatile static unsigned int TACTL @ 0x160;
```

The `volatile` qualifier does not guarantee that any access will be atomic, which is often not the case since the 8-bit PIC MCU architecture can only access a maximum of 1 byte of data per instruction.

The code produced by the compiler to access `volatile` objects can be different to that to access ordinary variables, and typically the code will be longer and slower for `volatile` objects, so only use this qualifier if it is necessary. However, failure to use this qualifier when it is required can lead to code failure.

Another use of the `volatile` keyword is to prevent unused global variables being removed. If a non-`volatile` variable is never used, or used in a way that has no effect, then it can be removed before code is generated by the compiler.

A C statement that consists only of a `volatile` variable's name will produce code that reads the variable's memory location and discards the result. For example, the entire statement, `PORTB;` will produce assembly code that reads `PORTB`. This is useful for some peripheral registers that require reading to reset the state of interrupt flags.

Some variables are treated as being `volatile` even though they are not qualified. See [Section 5.12.3.5 "Undefined Symbols"](#) if you have assembly code in your project.

## 5.4.8 Special Type Qualifiers

The MPLAB XC8 C Compiler supports special type qualifiers to allow the user to control placement of `static` and `extern` class variables into particular address spaces.

### 5.4.8.1 PERSISTENT TYPE QUALIFIER

By default, any C variables that are not explicitly initialized are cleared on startup. This is consistent with the definition of the C language. However, there are occasions where it is desired for some data to be preserved across a Reset.

The `persistent` type qualifier (or `__persistent`) is used to qualify variables that should not be cleared by the runtime startup code.

In addition, any `persistent` variables will be stored in a different area of memory to other variables. Different psects are used to hold these objects. See [5.15.2 Compiler-Generated Psects](#) for more information.

This type qualifier cannot be used on variables of class `auto`; however, statically defined local variables can be qualified `persistent`. For example, you should write:

```
void test(void)
{
    static persistent int intvar; /* must be static */
    // ...
}
```

If the `xc8` option, `--STRICT` is used, you cannot use the `persistent` qualifier, but you can continue to use `__persistent`.

### 5.4.8.2 NEAR TYPE QUALIFIER

Some of the 8-bit PIC architectures implement data memory which can be always accessed regardless of the currently selected bank. This *common memory* can be used to reduce code size and execution times as the bank selection instructions that are normally required to access data in banked memory are not required when accessing the common memory. PIC18 devices refer to this memory as the access bank memory. Mid-range and baseline devices have very small amounts of this memory, if it is present at all. PIC18 devices have substantially more common memory, but the amount differs between devices. See your device data sheet for more information.

The `near` type qualifier (or `__near`) can be used to place global variables in common memory. This qualifier cannot be used with `auto` or `static` local objects.

The compiler automatically uses the common memory for frequently accessed user-defined variables so this qualifier would only be needed for special memory placement of objects, for example if C variables are accessed in hand-written assembly code that assumes that they are located in this memory.

This qualifier is controlled by the compiler option `--ADDRQUAL`, which determines its effect, see [Section 4.8.15 "--ADDRQUAL: Set Compiler Response to Memory Qualifiers"](#). Based on this option's settings, this qualifier can be binding or ignored (which is the default operation). Qualifiers which are ignored will not produce an error or warning, but will have no effect.

Here is an example of an `unsigned char` object qualified as `near`:

```
near unsigned char fred;
```

Note that the compiler can store some temporary objects in the common memory, so not all of this space can be available for user-defined variables.

If the `xc8` option, `--STRICT` is used, the `near` qualifier is no longer available, but you can continue to use `__near`.

## 5.4.8.3 FAR TYPE QUALIFIER

The `far` type qualifier (or `__far`) is used to place global variables into the program memory space for those PIC18 devices that can support external memory. It will be ignored when compiling for PIC10/12/16 targets. This qualifier cannot be used with `auto` or `static` local objects.

The compiler assumes that `far` variables will be located in RAM that is implemented in the external memory space.

Access of `far` variables are less efficient than that of internal variables and will result in larger, slower code.

This qualifier is controlled by the compiler option `--ADDRQUAL`, which determines its effect on PIC18 devices, see [Section 4.8.15 “--ADDRQUAL: Set Compiler Response to Memory Qualifiers”](#). Based on this option's settings, this qualifier can be binding or ignored (which is the default operation). Qualifiers which are ignored will not produce an error or warning, but will have no effect.

Here is an example of an `unsigned int` object placed into the device's external program memory space:

```
far unsigned int farvar;
```

If the `--STRICT` is used, you can only use the `__far` form of the qualifier.

Note that not all PIC18 devices support external memory in their program memory space and, thus, the `far` qualifier is not applicable to all PIC18 devices. On supported devices, the address range where the additional memory will be mapped must first be specified with the `--RAM` option, [Section 4.8.52 “--RAM: Adjust RAM Ranges”](#). For example, to map additional data memory from 20000h to 2FFFFh use

```
--RAM=default,+20000-2FFFF.
```

## 5.4.8.4 BANK0, BANK1, BANK2 AND BANK3 TYPE QUALIFIERS

The `bank0`, `bank1`, `bank2` and `bank3` type qualifiers are recognized by the compiler and allow some degree of control of the placement of objects in the device's data memory banks. When compiling for PIC18 targets, these qualifiers are only accepted for portability and have no effect on variable placement; on other devices they can be used to define C objects that are assumed to be located in certain memory banks by hand-written assembly code. The compiler automatically allocates variables to all data banks, so these qualifiers are not normally needed.

Although a few devices implement more than 4 banks of data RAM, bank qualifiers to allow placement into these upper banks are not currently available.

These qualifiers are controlled by the compiler option `--ADDRQUAL`, which determines their effect, see [Section 4.8.15 “--ADDRQUAL: Set Compiler Response to Memory Qualifiers”](#). Based on this option's settings, these qualifiers can be binding or ignored (which is the default operation). Qualifiers which are ignored will not produce an error or warning, but will have no effect.

Objects qualified with any of these qualifiers cannot be `auto` or parameters to a function, but can be qualified `static`, allowing them to be defined locally within a function, as in:

```
void myFunc(void) {  
    static bank1 unsigned char play_mode;
```

If the `xc8` option, `--STRICT` is used, these qualifiers are changed to `__bank0`, `__bank1`, `__bank2` and `__bank3`.



## 5.4.8.5 EEPROM TYPE QUALIFIER

The `eeprom` type qualifier (or `__eeprom`) is recognized by the compiler for baseline and mid-range devices only and indicates that objects should be placed in the EEPROM memory. Not all devices implement EEPROM memory. Check your device data sheet for more information. A warning is produced if the qualifier is not supported for the selected device.

Objects qualified with this qualifier cannot be `auto` or parameters to a function, but can be qualified `static`, allowing them to be defined locally within a function, as in:

```
void myFunc(void) {  
    static eeprom unsigned char inputData[3];  
}
```

See [Section 5.5.5 “Variables in EEPROM”](#) for more information on these variables and other ways of accessing the EEPROM.

If the `--STRICT` option is used, only the `__eeprom` form of this qualifier is available.

## 5.5 MEMORY ALLOCATION AND ACCESS

There are two broad groups of RAM-based variables: auto/parameter variables, which are allocated to some form of stack, and global/static variables, which are positioned freely throughout the data memory space at static locations. The memory allocation of these two groups is discussed separately in the following sections.

### 5.5.1 Address Spaces

All 8-bit PIC devices have a Harvard architecture, which has a separate data memory (RAM) and program memory space (often flash). Some devices also implement EEPROM.

The data memory uses banking to increase the amount of available memory (referred to in the data sheets as the *general purpose register file*) without having to increase the assembly instruction width. One bank is “selected” by setting one or more bits in an SFR. (Consult your device data sheet for the exact operation of the device you are using.) Most instructions which access a data address use only the offset into the currently selected bank to access data. The exceptions are the PIC18 instructions MOVFF and MOVFFL, which take a full banked address and operates independently of the selected bank. Some devices only have one bank but many have more than one.

Both the general purpose RAM and SFRs both share the same data space and can appear in all available memory banks. PIC18 devices have all SFRs in the one data bank, but mid-range and baseline devices have SFRs at the lower addresses of each bank. Due to the location of SFRs in these devices, the general purpose memory becomes fragmented and this limits the size of most C objects.

The Enhanced mid-range devices overcome this fragmentation by allowing a linear addressing mode, which allows the general purpose memory to be accessed as one contiguous chunk. Thus, when compiling for these devices, the maximum allowable size of objects typically increases. Objects defined when using PIC18 devices can also typically use the entire data memory. See [Section 5.5.2.2.3 “Size Limits of Auto Variables”](#) and [Section 5.5.2.1.2 “Non-Auto Variable Size Limits”](#).

Many devices have several bytes which can be accessed regardless of which bank is currently selected. This memory is called *common memory*. The PIC18 data sheets refer to the bank in which this memory is stored as the access bank, and hence it is often referred to as the access bank memory. Since no code is required to select a bank before accessing these locations, access to objects in this memory is typically faster and produces smaller code. The compiler always tries to use this memory if possible.

The program memory space is primarily for executable code, but data can also be located here. There are several ways the different device families locate and read data from this memory, but all objects located here will be read-only.

## 5.5.2 Variables in Data Space Memory

Most variables are ultimately positioned into the data space memory. The exceptions are non-`auto` variables which are qualified as `const`, which are placed in the program memory space, or `eeprom` qualified variables.

Due to the fundamentally different way in which `auto` variables and non-`auto` variables are allocated memory, they are discussed separately. To use the C language terminology, these two groups of variables are those with automatic storage duration and those with permanent storage duration, respectively.

**Note:** The terms “local” and “global” are commonly used to describe variables, but are not ones defined by the language Standard. The term “local variable” is often taken to mean a variable which has scope inside a function, and “global variable” is one which has scope throughout the entire program. However, the C language has three common scopes: block, file (i.e., internal linkage) and program (i.e., external linkage), so using only two terms to describe these can be confusing. For example, a `static` variable defined outside a function has scope only in that file, so it is not globally accessible, but it can be accessed by more than one function inside that file, so it is not local to any one function, either.

### 5.5.2.1 NON-AUTO VARIABLE ALLOCATION

Non-`auto` variables (those with permanent storage duration) are located by the compiler into any of the available data banks. This is done in a two-stage process: placing each variable into an appropriate psect and later linking that psect into a predetermined bank. See [Section 5.15.1 “Program Sections”](#) for an introductory guide to psects. Thus, during compilation, the code generator can determine which bank will hold each variable and encode the output accordingly, but it will not know the exact location within that bank.

The compiler will attempt to locate all variables in one bank (i.e., place all variables in the psect destined for this bank), but if this fills (i.e., if the compiler detects that the psect has become too large for the free space in a bank), variables will be located in other banks via different psects. Qualifiers are not required to have these variables placed in banks other than bank 0 but can be used if you want to force a variable to a particular bank. See [Section 5.4.8.4 “Bank0, Bank1, Bank2 and Bank3 Type Qualifiers”](#) and [Section 4.8.15 “--ADDRQUAL: Set Compiler Response to Memory Qualifiers”](#) for more information on how to do this. If common memory is available on the target device, this will also be considered for variables. This memory can be limited in size and can be reserved for special use, so only a few variables can be allocated to it.

The compiler considers three categories of non-`auto` variables, which all relate to the value the variable should contain by the time the program begins. Each variable category has a corresponding psect which is used to hold the output code which reserves memory for each variable. The base name of each psect category is tabulated below. A full list of all psect names are in [Section 5.15.2 “Compiler-Generated Psects”](#).

<code>nv</code>	These psects are used to store variables qualified <code>persistent</code> , whose values should not be altered by the runtime startup code. They are not cleared or otherwise modified at startup.
<code>bss</code>	These psects contain any uninitialized variables, which are not assigned a value when they are defined, or variables which should be cleared by the runtime startup code.
<code>data</code>	These psects contain the RAM image of any initialized variables, which are assigned a non-zero initial value when they are defined and which must have a value copied to them by the runtime startup code.

As described in [Section 5.10 “Main, Runtime Startup and Reset”](#), the base name of data space psects is always used in conjunction with a linker class name to indicate the RAM bank in which the psect will be positioned. This section also lists other variants of these psects and indicates where these psect must be linked. See also [Section 5.15.2 “Compiler-Generated Psects”](#) for more information on how initial values are assigned to the variables.

Note that the `data` psect used to hold initialized variables is the psect that holds the RAM variables themselves. There is a corresponding psect (called `idata`) that is placed into program memory (so it is non-volatile) and which is used to hold the initial values that are copied to the RAM variables by the runtime startup code.

All non-`auto` variables, except for `static` variables, discussed in [Section 5.5.2.1.1 “Static Variables”](#), always use their lexical name with a leading *underscore* character as the assembly identifier used for this object. See [Section 5.12.3.1 “Equivalent Assembly Symbols”](#) for more information on the mapping between C- and assembly-domain symbols.

### 5.5.2.1.1 Static Variables

All `static` variables have permanent storage duration, even those defined inside a function which are “local static” variables. Local `static` variables only have scope in the function or block in which they are defined, but unlike `auto` variables, their memory is reserved for the entire duration of the program. Thus they are allocated memory like other non-`auto` variables.

All `static` variables can be accessed by other functions via pointers since they have permanent duration.

Local `static` variables are guaranteed to retain their value between calls to the function in which they are defined, unless explicitly modified via a pointer.

Variables which are `static` and which are initialized only have their initial value assigned once during the program's execution. Thus, they can be preferable over initialized `auto` objects which are assigned a value every time the block in they are defined begins execution. Any initialized `static` variables are initialized in the same way as other non-`auto` initialized objects by the runtime startup code, see [Section 4.4.2 “Startup and Initialization”](#).

All `static` variables which are also specified as `const` will be stored in program memory, like any other non-`auto` variable.

The assembly symbols used to access static objects in assembly code are discussed in [Section 5.12.3.1 “Equivalent Assembly Symbols”](#).

## 5.5.2.1.2 Non-Auto Variable Size Limits

Arrays of any type (including arrays of aggregate types) are fully supported by the compiler. So too are the structure and union aggregate types, see [5.4.4 Structures and Unions](#). These objects can often become large in size and can affect memory allocation.

When compiling for enhanced mid-range PIC devices, the size of an object (array or aggregate object) is typically limited only by the total available data memory. Single objects that will not fit into any of the available general purpose RAM ranges will be allocated memory in several RAM banks and accessed using the device's linear GPR (general purpose RAM).

Note that the special function registers (which reside in the data memory space) or memory reservations in general purpose RAM can prevent objects from being allocated contiguous memory in the one bank. In this case objects that are smaller than the size of a RAM bank can also be allocated across multi-banks. The generated code to access multi-bank objects will always be slower and the associated code size will be larger than for objects fully contained within a single RAM bank.

When compiling for PIC18 devices, the size of an object is also typically limited only by the data memory available. Objects can span several data banks.

On baseline and other mid-range devices, arrays and structures are limited to the maximum size of the available GPR memory in each RAM bank, not the total amount of memory remaining. An error will result if an array is defined which is larger than this size.

With any device, reserving memory in general purpose RAM (see [Section 4.8.52 "--RAM: Adjust RAM Ranges"](#)), or defining absolute variables in the middle of data banks (see [Section 5.5.4 "Absolute Variables"](#)), further restricts the contiguous memory in the data banks and can reduce the maximum size of objects you can define.

## 5.5.2.1.3 Changing the Default Non-Auto Variable Allocation

There are several ways in which non-`auto` variables can be located in locations other than those chosen by the compiler.

Variables can be placed in other memory spaces by the use of qualifiers. For example if you wish to place variables in the program memory space, then the `const` specifier should be used (see [Section 5.4.7.1 "Const Type Qualifier"](#)). The `eeeprom` qualifier (see [5.4.8.5 Eeprom Type Qualifier](#)) can be used to allocate variables to the EEPROM, if such memory exists on your target device.

If you wish to prevent variables from using one or more data memory locations so that these locations can be used for some other purpose, you are best reserving the memory using the memory adjust options. See [Section 4.8.52 "--RAM: Adjust RAM Ranges"](#) for information on how to do this.

If only a few non-`auto` variables are to be located at specific addresses in data space memory, then the variables can be made absolute. This allows individual variables to be explicitly positioned in memory at an absolute address. Absolute variables are described in [Section 5.5.4 "Absolute Variables"](#). Once variables are made absolute, their address is hard coded in generated output code, they are no longer placed in a psect and do not follow the normal memory allocation procedure.

The psects in which the different categories of non-auto variables (the `nv`, `bss` and `data` psects described in [Section 5.5.2.1 “Non-Auto Variable Allocation”](#)) can be shifted as a whole by changing the default linker options. So, for example, you could move all the persistent variables. However, typically these psects can only be moved within the data bank in which they were allocated by default. See [Section 5.10 “Main, Runtime Startup and Reset”](#), for more information on changing the default linker options for psects. The code generator makes assumptions as to the location of these psects and if you move them to a location that breaks these assumptions, code can fail.

Non-auto can also be placed at specific positions by using the `__section()` specifier, see [Section 5.15.4 “Changing and Linking the Allocated Section”](#). The decision whether variables should be positioned this way or using absolute variables should be based on the location requirements.

## 5.5.2.2 AUTO VARIABLE ALLOCATION AND ACCESS

This section discusses allocation of `auto` variables (those with automatic storage duration) to a data stack. This also includes function parameter variables, which behave like `auto` variables, in terms of their storage duration and scope. Temporary variables defined by the compiler also fall into this group. They are identical to `auto` variables, except they are defined by the compiler and, hence, have no C name. Together, these objects are often called stack-based objects.

The `auto` (short for *automatic*) variables are the default type of local variable. Unless explicitly declared to be `static`, a local variable will be made `auto`. The `auto` keyword can be used if desired.

The `auto` variables, as their name suggests, automatically come into existence when a function is executed, then disappear once the function returns. Since they are not in existence for the entire duration of the program, there is the possibility to reclaim memory they use when the variables are not in existence and allocate it to other variables in the program.

Typically such variables are stored on some sort of a dynamic data stack where memory can be easily allocated and deallocated by each function. This is not possible on all 8-bit devices supported by MPLAB XC8. Nor is it the most efficient means of storing objects.

MPLAB XC8 has two methods of implementing data stacks for stack-based variables: a compiled stack and a software stack<sup>1</sup>. [Section 5.3.4 “Stacks”](#) describes all the stacks used by MPLAB XC8 and the 8-bit PIC devices.

Each C function is compiled to use exactly one of these stacks. The stack used affects whether a function allows reentrancy. If a function is encoded to place its stack-based objects on the software stack, it is said to be using a reentrant function model. A function uses a non-reentrant function model if it places its stack-based objects on the compiled stack. This information is summarized in [Table 5-11](#) along with the devices that support each model. The function model directly implies the stack used by a function. See subsections below for specific details on how the compiled stack and software stack operate.

**TABLE 5-11: FUNCTION MODELS IMPLEMENTATION**

Function Model	Data Stack Used	Supported Device Families
Non-reentrant	Compiled stack	All devices
Reentrant	Software stack	Enhanced mid-range and PIC18 devices

---

1. What is referred to as a software stack in this user's guide is the typical dynamic stack arrangement employed by most computers. It is ordinary data memory accessed by some sort of push and pop instructions, and a stack pointer register.

When compiling for those devices that do not support the reentrant function model, all functions are encoded to use the compiled stack, and these functions are non-reentrant.

For the enhanced mid-range and PIC18 devices, by default the compiler will use the non-reentrant model for all functions. Alternatively the user can dictate which functions are to be compiled reentrantly (and those which are not) by using compiler options or function specifiers. There is also a hybrid stack mode which allows the compiler to choose which functions need to be compiled using a reentrant model and which can use the non-reentrant model. The hybrid mode allows the program to use recursion but still take advantage of the more efficient compiled stack.

The `--STACK` option (see [Section 4.8.59 “--STACK: Specify Data Stack Type For Entire Program”](#)) can be used to change the compiler’s default behavior when assigning function models. Set the `--STACK` option to `software` so the compiler will always choose the reentrant model (software stack) for each function. If the `--STACK` option is set to `compiled` or this option is omitted, all functions are encoded to use the non-reentrant (compiled stack) function model. Set this option to `hybrid` for hybrid stack mode and to allow the compiler to decide how each function should be encoded.

In hybrid mode the compiler will choose a function model based on how the function is called in the program. If the function is not reentrantly called, then it will be encoded to use the non-reentrant model and the compiled stack. If the function appears in more than one call graph (i.e., it is called from main-line and interrupt code), or it appears in a loop in a call graph (i.e., it is called recursively), then the compiler will use the reentrant model.

The `--STACK` option’s `software` and `compiled` settings changes the function model for *all* functions. You can change the function model for *individual* functions by using function specifiers when you define the function.

Use either the `compiled` or `nonreentrant` specifier (identical meanings) to indicate that the specified function must use the compiled stack, without affecting any other function. Alternatively, use either the `software` or `reentrant` specifier to indicate a function must be encoded to use the software stack.

The function specifiers have precedence over the `--STACK` option setting. If, for example, the option `--STACK=compiled` has been used, but one function uses the `software` (or `reentrant`) specifier, then the specified function will use the software stack and all the remaining functions will use the compiled stack. These function specifiers also override any choice made by the compiler in hybrid mode.

If a function has been specified as `compiled` (or `nonreentrant`), or the `--STACK=compiled` option has been issued, and that function appears in more than one call graph in the program, then the usual function duplication feature automatically comes into effect. See [Section 5.9.7 “Function Duplication”](#), for more information on how this is performed. Duplicating a non-reentrant function allows it to be called from multiple call graphs, but cannot be used if the function is called recursively.

The `auto` variables defined in a function will not necessarily be allocated memory in the order declared, in contrast to parameters which are always allocated memory based on their lexical order. In fact, `auto` variables for one function can be allocated in many RAM banks.

The standard qualifiers: `const` and `volatile` can both be used with `auto` variables and these do not affect how they are positioned in memory. This implies that a local `const`-qualified object is still an `auto` object and, as such, will be allocated memory in the stack in the data space memory, not in the program memory as with non-`auto` `const` objects. If you want to define a local-scope object that is placed in program memory, specify it as `static const`.



The compiler will try to locate the stack in one data bank, but if this fills (i.e., if the compiler detects that the stack psect has become too large), it can build up the stack into several components (each with their own psect) and link each in a different bank.

Each `auto` object is referenced in assembly code using a special symbol defined by the code generator. If accessing auto variables defined in C source code, you must use these symbols, which are discussed in [Section 5.12.3 “Interaction between Assembly and C Code”](#).

## 5.5.2.2.1 Compiled Stack Operation

A compiled stack consists of fixed memory areas that are usable by each function's stack-based variables. When a compiled stack is used, functions are not re-entrant since stack-based variables in each function will use the same fixed area of memory every time the function is invoked.

Fundamental to the generation of the compiled stack is the call graph, which defines a tree-like hierarchy of function calls, i.e. it shows what functions can be called by each function.

There will be one graph produced for each root function. A root function is typically not called, but which is executed via other means and contains a program entry point. The function `main()` is an example of a root function that will be in every project. Interrupt functions which are executed when a hardware interrupt occurs, are another example.

**FIGURE 5-1: FORMATION OF CALL GRAPH**

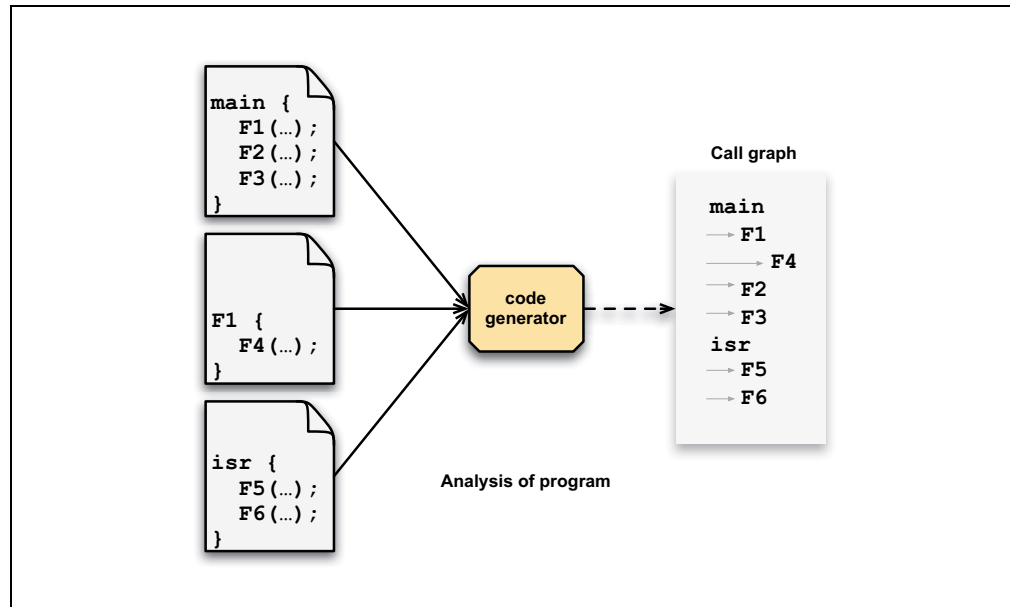

Figure 5-1 shows sections of a program being analyzed by the code generator to form a call graph. In the original source code, the function `main()` calls `F1()`, `F2()` and `F3()`. `F1()` calls `F4()`, but the other two functions make no calls. The call graph for `main()` indicates these calls. The symbols `F1`, `F2` and `F3` are all indented one level under `main`. `F4` is indented one level under `F1`.



This is a static call graph which shows all possible calls. If the exact code for function `F1()` looked like:

```
int F1(void) {
    if(PORTA == 44)
        return F4();
    return 55;
}
```

the function `F4()` will always appear in the call graph, even though it is conditionally executed in the actual source code. Thus, the call graph indicates all functions that *might* be called.

In the diagram, there is also an interrupt function, `isr()`, and it too has a separate graph generated.

The term main-line code is often used, and refers to any code that is executed as a result of the `main()` function being executed. In the above figure, `F1()`, `F2()`, `F3()` and `F4()` are only ever called by main-line code.

The term interrupt code refers to any code that is executed as a result of an interrupt being generated, in the above figure, `F5()` and `F6()` are called by interrupt code.

Figure 5-2 graphically shows an example of how the compiled stack is formed.

**FIGURE 5-2: FORMATION OF THE COMPILED STACK**

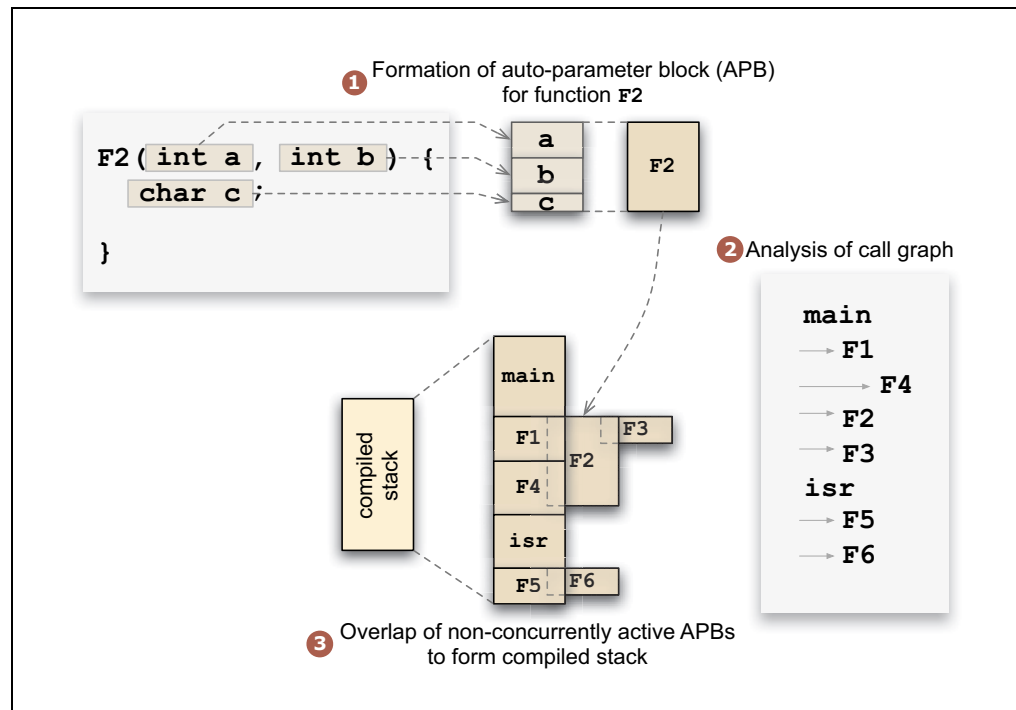

Each function in the program is allocated a block of memory for its parameter, `auto` and temporary variables. Each block is referred to as an auto-parameter block (APB). The figure shows the APB being formed for function `F2()`, which has two parameters, `a` and `b`, and one `auto` variable, `c`.

The parameters to the function are first grouped in an order strictly determined by the lexical order in which they appear in the source code. These are then followed by any `auto` objects; however, the `auto` objects can be placed in any order. So we see memory for `a` is followed by that for `b` and lastly `c`.

Once these variables have been grouped, the exact location of each object is not important at this point and we can represent this memory by one block — the APB for this function.

The APBs are formed for all functions in the program. Then, by analyzing the call graph, these blocks are assigned positions, or base values, in the compiled stack.

Memory can be saved if the following point is observed: If two functions are never active at the same time, then their APBs can be overlapped.

In the example shown in the figure, `F4()` and `F1()` are active at the same time, in fact `F1()` calls `F4()`. However, `F2()`, `F3()` and `F1()` are never active at the same time; `F1()` must return before `F2()` or `F3()` can be called by `main()`. The function `main()` will always be active and so its APB can never overlap with that of another function.

In the compiled stack, you can see that the APB for `main()` is allocated unique memory. The blocks for `F1()`, `F2()` and `F3()` are all placed on top of each other and the same base value in the compiled stack; however, the memory taken up by the APBs for `F1()` and `F4()` are unique and do not overlap.

Our example also has an interrupt function, `isr()`, and its call graph is used to assemble the APBs for any interrupt code in the same way. Being the root of a graph, `isr()` will always be allocated unique memory, and the APBs for interrupt functions will be allocated memory following.

The end result is a block of memory which forms the compiled stack. This block can then be placed into the device's memory by the linker.

Once `auto` variables have been allocated a relative position in the compiled stack, the stack itself is then allocated memory in the data space. This is done in a similar fashion to the way other variables are assigned memory: a `psect` is used to hold the stack and this `psect` is placed into the available data memory by the linker. The `psect` base name used to hold the compiled stack is called `cstack`, and, like with other `psects`, the base name is always used in conjunction with a linker class name to indicate the RAM bank in which the `psect` will be positioned. See [Section 5.15.2 “Compiler-Generated Psects”](#) for the limitations associated with where this `psect` can be linked.

For devices with more than one bank of data memory, the compiled stack can be built up into components, each located in a different memory bank. The compiler will try to allocate the compiled stack in one bank, but if this fills, it will consider other banks. The process of building these components of the stack is the same, but each function can have more than one APB and these will be allocated to one of the stack components based on the remaining memory in the component's destination bank.

Human readable symbols are defined by the code generator which can be used to access `auto` and parameter variables in the compiled stack from assembly code, if required. See [Section 5.12.3 “Interaction between Assembly and C Code”](#) for full information between C domain and assembly domain symbols.

#### 5.5.2.2.2 Software Stack Operation

Functions using a software stack (reentrant model) dynamically allocate memory for their stack-based variables in a region of memory specifically reserved for this software stack.

Allocation starts at one end of this reserved area, and the stack memory grows as new function instances come into existence. When a function using the reentrant model exits, any stack memory it used is freed and made available for other functions. The stack grows up in memory, toward larger addresses.

Main-line code and each interrupt routine use unique areas in the stack space. The maximum size allocated to each area can be specified using the `--STACK` option, see [Section 4.8.59 “--STACK: Specify Data Stack Type For Entire Program”](#).

MPLAB XC8 designates a register, known as the stack pointer, which always holds the address of the next free location in the software stack. The register used by the stack pointer is FSR1 for both enhanced mid-range and PIC18 devices. The address held by the stack pointer is increased when variables are allocated (pushed) to the stack; it is decreased when a function returns and variables are removed (popped) from the stack.

Note that if there are *any* functions in the program that are reentrantly encoded, the FSR1 register is reserved for the stack pointer for the entire program's duration, even when executing code associated with non-reentrant functions. With this register unavailable for use with general statements, the code generated may be less efficient or "Can't generate code" errors may result.

The stack pointer is reloaded when an interrupt occurs so it accesses the interrupt function's unique stack area. It is restored by the interrupt context switch code when the interrupt routine is complete.

There is no register assigned to hold a frame pointer. All access of stack-based objects must use an address that is an offset from the stack pointer.

When a function is called, any arguments to that function are pushed onto the stack by the calling function, in a reverse order to that in which the corresponding parameters appear in the function's prototype. If required, the called function will increase the value stored in the stack pointer to allocate storage for any `auto` or temporary variables it needs to allocate.

If the reentrant function returns a value on the stack (this might happen for return values larger than 4 bytes in size), the calling function will adjust the stack to remove the return value.

Recall that a function's return address is not stored on this stack. It is automatically stored on the hardware stack by the device, see [Section 5.3.4.1 "Function Return Address Stack"](#).

The compiler can detect if the software stack memory requirements for each function will exceed set limits. These limits are 127 bytes for PIC18 devices and typically 31 bytes for enhanced mid-range devices. Note that the compiler cannot detect for overflow of the memory reserved for the stack as a whole. There is no runtime check made for software stack overflows. If the software stack overflows, data corruption and code failure might result.

When reentrant functions call other reentrant functions, the stack pointer is incremented as any parameters to the called function are loaded. This increases the offset from the new top-of-stack position to the stack-based objects defined by the calling function. If this offset becomes too large, a warning (1488) or error might result when trying to access stack-based objects in the calling function. A similar situation exists if the called reentrant function returns a value, as this might also be located on the stack. For these reasons, the entire stack depth might not be usable for every function.

#### 5.5.2.2.3 Size Limits of Auto Variables

The compiled stack is built up as one contiguous block which can be placed into one of the available data banks. However, if the stack becomes too large for this space, it can be assembled into several blocks, with each block being positioned in a different bank of memory. Thus the total size of the stack is roughly limited only by the available memory on the device.

Unlike with non-`auto` variables, it is not efficient to access `auto` variables within the compiled stack using the linear memory of enhanced mid-range devices. For all devices, including PIC18 and Enhanced mid-range PIC MCUs, each component of the compiled stack must fit entirely within one bank of data memory on the target device (however, you can have more than one component, each allocated to a different bank). This limits the size of objects within the stack to the maximum free space of the bank in which it is allocated. The more `auto` variables in the stack; the more restrictive the space is to large objects. Recall that SFRs on mid-range devices are usually present in each data bank, so the maximum amount of GPR available in each bank is typically less than the bank size for these devices.

The software stack is always allocated one block of memory. This memory may cross bank boundaries. The size is typically limited by the amount of free data space remaining. An `auto` object placed on the software stack may be any size, providing it fits in the allocated stack space. It may be allocated memory that crosses a bank boundary and will always be accessed via the stack pointer, FSR1.

If a program requires large objects that should not be accessible to the entire program, consider leaving them as local objects, but using the `static` specifier. Such variables are still local to a function, but are no longer `auto` and have fewer size limitations. They are allocated memory as described in [Section 5.5.2.1 “Non-Auto Variable Allocation”](#).

#### 5.5.2.2.4 Changing the Default Auto Variable Allocation

As `auto` variables are stack based, there is no means to move them. They cannot be made absolute, nor can they be moved using the `__section()` specifier.

The psects in which the `auto` variables reside can be shifted as a whole by changing the default linker options. However, these psects can only be moved within the data bank in which they were allocated by default. See [Section 5.10 “Main, Runtime Startup and Reset”](#) for more information on changing the default linker options for psects. The code generate makes assumptions as to the location of these psects and if you move them to a location that breaks these assumptions, code can fail.

### 5.5.3 Variables in Program Space

The only variables that are placed into program memory are those that are not `auto` and which have been qualified `const`. Any `auto` variables qualified `const` are placed in the compiled stack along with other `auto` variables, and all components of the compiled stack will only ever be located in the data space memory.

Any `const`-qualified (`auto` or non-`auto`) variable will always be read-only and any attempt to write to these in your source code will result in an error being issued by the compiler.

On some 8-bit PIC devices, the program space is not directly readable by the device. For these devices, the compiler stores data in the program memory by means of `RETLW` instructions which can be called, and which will return a byte of data in the `W` register. The compiler will generate the code necessary to make it appear that program memory is being read directly.

Enhanced mid-range PIC devices can directly read their program memory, although the compiler will still usually store data as `RETLW` instructions. This way the compiler can either produce code that can call these instructions to obtain the program memory data as with the ordinary mid-range devices, or directly read the operand to the instruction (the LSB of the `RETLW` instruction). The most efficient access method can be selected by the compiler when the data needs to be read.

Data can be stored as individual bytes in the program memory of PIC18 devices. This can be read using table read instructions.

On all devices, accessing data located in program memory is much slower than accessing objects in the data memory. The code associated with the access is also larger.

A `const` object is usually defined with initial values, as the program cannot write to these objects at runtime. However, this is not a requirement. An uninitialized `const` object can be defined to define a symbol, or label, but not make a contribution to the output file. Uninitialized `const` objects are often made absolute, see [Section 5.5.4 “Absolute Variables”](#). Here are examples of `const` object definitions.

```
const char I0type = 'A'; // initialized const object
const char buffer[10]; // I just define a label
```

The data held by non-`auto` `const` variables is placed in one of several psects, based on the target device. See [Section 5.15.2 “Compiler-Generated Psects”](#) for the limitations associated with where these psects can be linked.

See [Section 5.12.3 “Interaction between Assembly and C Code”](#) for the equivalent assembly symbols that are used to represent `const`-qualified variables in program memory.

## 5.5.3.1 SIZE LIMITATIONS OF CONST VARIABLES

Arrays of any type (including arrays of aggregate types) can be qualified `const` and placed in the program memory. So too can structure and union aggregate types, see [5.4.4 Structures and Unions](#). These objects can often become large in size and can affect memory allocation.

For baseline PIC devices, the maximum size of a single `const` object is 255 bytes. However, you can define as many `const` objects as required provided the total size does not exceed the available program memory size of the device. Note that as well as other program code, there is also code required to be able to access `const`-qualified data in the program memory space. Thus, you can need additional program memory space over the size of the object itself. This additional code to access the `const` data is only included once, regardless of the amount or number of `const`-qualified objects.

For all other 8-bit devices, the maximum size of a `const`-qualified object is limited only by the available program memory. These devices also use additional code that accesses the `const` data. PIC18 devices need additional code each time an object is accessed, but this is typically small. The mid-range devices include a larger routine, but this code is also only included once, regardless of the amount or number of `const`-qualified objects.

## 5.5.3.2 CHANGING THE DEFAULT ALLOCATION

If you only intend to prevent all variables from using one or more program memory locations so that you can use those locations for some other purpose, you are best reserving the memory using the memory adjust options. See [Section 4.8.53 “--ROM: Adjust ROM Ranges”](#) for information on how to do this.

If only a few non-`auto` `const` variables are to be located at specific addresses in program space memory, then the variables can be made absolute. This allows individual variables to be explicitly positioned in memory at an absolute address. Absolute variables are described in [Section 5.5.4 “Absolute Variables”](#). Once variables are made absolute, their address is hard coded in generated output code, they are no longer placed in a psect and do not follow the normal memory allocation procedure.

The psects in which the different categories of non-`auto` `const` variables can be shifted as a whole by changing the default linker options. However, there are limitations in where these psects can be moved to. See [Section 5.10 “Main, Runtime Startup and Reset”](#) for more information on changing the default linker options for these psects.

Variables in program memory can also be placed at specific positions by using the `__section()` specifier, see [Section 5.15.4 “Changing and Linking the Allocated Section”](#). The decision whether variables should be positioned this way or using absolute variables should be based on the location requirements.

## 5.5.4 Absolute Variables

Most variables can be located at an absolute address by following its declaration with the construct `@ address`, where `address` is the location in memory where the variable is to be positioned. Such a variable is known as an absolute variable.

The compiler does not make any checks for overlap of absolute variables with other absolute variables, so this must be considered when choosing the variable locations. No warning will be issued if the address of an absolute object lies outside the memory of the device or outside the memory defined by the linker classes. There is no harm in defining more than one absolute variable to live at the same address if this is what you require. The compiler will not locate ordinary variables over the top of absolutes.

### 5.5.4.1 ABSOLUTE VARIABLES IN DATA MEMORY

Absolute variables are primarily intended for equating the address of a C identifier with a special function register, but can be used to place ordinary variables at an absolute address in data memory. The `auto` variables cannot be made absolute as they are located in a stack. Nor can you make `static` local objects absolute.

For example:

```
volatile unsigned char Portvar @ 0x06;
```

will declare a variable called `Portvar` located at 06h in the data memory. The compiler will reserve storage for this object (if the address falls into general-purpose RAM) and will equate the variable's identifier to that address.

Objects should not be made absolute to force them into common (unbanked) memory. Always use the `near` qualifier for this purpose (see [Section 5.4.8.2 “Near Type Qualifier”](#)). Objects defined by the compiler have first priority for common memory. Common memory remaining after the compiler has allocated special variables in this area is then available for objects qualified `near`.

**Note:** Defining absolute objects can fragment memory and can make it impossible for the linker to position other objects. Avoid absolute objects if at all possible. If absolute objects must be defined, try to place them at either end of a memory bank or page so that the remaining free memory is not fragmented into smaller chunks.

When defining absolute `bit` variables (see [Section 5.4.2.1 “Bit Data Types and Variables”](#)), the address specified must be a bit address. A bit address is obtained by multiplying the desired byte address by 8, then adding the bit offset within that bit. So, for example, to place a `bit` variable called `mode` at bit position #2 at byte address 0x50, use the following:

```
bit mode @ 0x282;
```

If you wish to place a `bit` variable over an existing object (typically this will be an SFR variable or another absolute variable) then you can use the symbol of that object, as in the following example which places `flag` at bit position #3 in the `char` variable `MOT_STATUS`:

```
bit flag @ ((unsigned) &MOT_STATUS)*8 + 3;
```



When compiling for an enhanced mid-range PIC device, the memory allocated for some objects can be spread over multiple RAM banks. Such objects will only ever be accessed indirectly in assembly code, and will use the linear GPR memory implemented on these devices. A linear address (which can be mapped back to the ordinary banked address) will be used with these objects internally by the compiler.

The address specified for absolute objects on these devices can either be the traditional banked memory address or the linear address. As the linear addresses start above the largest banked address, it is clear which address is intended. In the following example:

```
int inputBuffer[100] @ 0x2000;
```

it is clear that `inputBuffer` should be placed at address 0x2000 in the linear address space, which is address 0x20 in bank 0 RAM in the traditional banked address space. See the device data sheet for exact details regarding your selected device.

Absolute variables in RAM cannot be initialized when they are defined. Define the absolute variables, then assign them a value at a suitable point in your main-line code.

#### 5.5.4.2 ABSOLUTE OBJECTS IN PROGRAM MEMORY

Non-`auto` objects qualified `const` can also be made absolute in the same way, however, the address will indicate an address in program memory. For example:

```
const int settings[] @ 0x200 = { 1, 5, 10, 50, 100 };
```

will place the array `settings` at address 0x200 in the program memory.

Both initialized and uninitialized `const` objects can be made absolute. That latter is useful when you only need to define a label in program memory without making a contribution to the output file.

Variables can also be placed at specific positions by using the `__section()` specifier, see [Section 5.15.4 "Changing and Linking the Allocated Section"](#). The decision whether variables should be positioned this way or using absolute variables should be based on the location requirements. Using absolute variables is the easiest method, but only allows placement at an address which must be known prior to compilation. The `__section()` specifier is more complex, but offers all the flexibility of the linker to position the new psect into memory. You can, for example, specify that variables reside at a fixed address, or that they be placed after other psects, or that they be placed anywhere in a compiler-defined or user-defined range of address.

## 5.5.5 Variables in EEPROM

For devices with on-chip EEPROM, the compiler offers several methods of accessing this memory. You can define named variables in this memory space, or use block-access routines to read or write EEPROM. The EEPROM access methods are described in the following sections.

### 5.5.5.1 EEPROM VARIABLES

When compiling for baseline and mid-range parts, the `eeeprom` qualifier allows you to create named C variables that reside in the EEPROM space. See [Section 5.4.8.5 “Eeprom Type Qualifier”](#).

Variables qualified `eeeprom` are cleared or initialized, just like ordinary RAM-based variables; however, the initialization process is not carried out by the runtime startup code. Initial values are placed into the HEX file and are burnt into the EEPROM when you program the device. Thus, if you modify the EEPROM during program execution and then reset the device, these variables will not contain the initial values specified in your code at startup.

The following example defines two arrays in EEPROM.

```
eeeprom char regNumber[10] = "A93213";
eeeprom int lastValues[3];
```

For both these objects, initial values will be placed into psects and will appear in the HEX file. Zeros will be used as the initial values for `lastValues`.

The generated code to access `eeeprom`-qualified variables will be much longer and slower than code to access RAM-based variables. You should avoid using `eeeprom`-qualified variables in complicated expressions. Consider copying values from the EEPROM to regular RAM-based variables and using these in your code.

### 5.5.5.2 EEPROM INITIALIZATION

For those devices that support external programming of their EEPROM data area, the `__EEPROM_DATA()` macro can be used to place initial values into the HEX file ready for programming. The macro is used as follows.

```
#include <xc.h>
__EEPROM_DATA(0, 1, 2, 3, 4, 5, 6, 7);
```

The macro has eight parameters, representing eight data values. Each value should be a byte in size. Unused values should be specified with zero.

The `__EEPROM_DATA()` macro expands into in-line assembly code. If expressions are used to evaluate the macro arguments, ensure that any operators or tokens in these expressions are written in assembly code (see [Section 6.2 “MPLAB XC8 Assembly Language”](#)).

The macro can be called multiple times to define the required amount of EEPROM data. It is recommended that the macro be placed outside any function definition.

This macro cannot be used to write to EEPROM locations during runtime; it is used for pre-loading EEPROM contents at program time only.

The values defined by this macro share the EEPROM space with any `eeeprom`-qualified variables. The macro cannot be used to initialize `eeeprom`-qualified variables. The psect used by this macro to hold the data values is different to those used by `eeeprom`-qualified variables. The link order of these psects can be adjusted, if required (see [Section 4.8.6 “-L-: Adjust Linker Options Directly”](#)).

For convenience, the macro `__EEPROMSIZE` represents the number of bytes of EEPROM available on the target device.



## 5.5.5.3 EEPROM ACCESS FUNCTIONS

The library functions `eeeprom_read()` and `eeeprom_write()`, can be called to read from, and write to, the EEPROM during program execution. They are available for all midrange devices which implement EEPROM. For PIC18 devices, calls to these routines will instead attempt to call the equivalent functions in the PIC18 peripheral library. It is recommended that for PIC18 devices you call the equivalent peripheral library functions directly or use MPLAB MCC to generate EEPROM access code.

The prototypes for these functions are as below.

```
#include <xc.h>
unsigned char eeeprom_read(unsigned char address);
void eeeprom_write(unsigned char address, unsigned char value);
```

These functions test and wait for any concurrent writes to EEPROM to conclude before performing the required operation. The `eeeprom_write()` function will initiate the process of writing to EEPROM and this process will not have completed by the time that `eeeprom_write()` returns. The new data written to EEPROM will become valid at a later time. See your device data sheet for exact information about EEPROM on your target device.

It can also be convenient to use the preprocessor symbol, `_EEPROMSIZE`, in conjunction with some of these access methods. This symbol defines the number of EEPROM bytes available for the selected chip.

## 5.5.5.4 EEPROM ACCESS MACROS

Macro versions of the EEPROM functions are also provided for midrange devices. For PIC18 devices, it is recommended that you call the equivalent PIC18 peripheral library functions directly or use MPLAB MCC to generate EEPROM access code. These macros perform similar operations to their function counterparts, with the exception of some timing issues described below. Use the macro forms of these routines for faster execution and to save a level of stack, but note that their repeated use will increase code size.

The usage of these macros for all devices is as follows.

```
EEPROM_READ(address)
EEPROM_WRITE(address, value)
```

The `EEPROM_READ` macro returns the byte read.

In the case of the baseline and mid-range macro `EEPROM_READ()`, there is another very important difference from the function version to note. Unlike `eeeprom_read()`, this macro does not wait for any concurrent EEPROM writes to complete before proceeding to select and read EEPROM. If it cannot be guaranteed that all writes to EEPROM have completed at the time of calling `EEPROM_READ()`, the appropriate flag should be polled prior to executing `EEPROM_READ()`.

For example:

```
#include <xc.h>
// wait for end-of-write before EEPROM_READ
while(WR)
    continue; // read from EEPROM at address
value = EEPROM_READ(address);
```

## 5.5.6 Variables in Registers

Allocating variables to registers, rather than to a memory location, can make code more efficient. With MPLAB XC8, there is no direct control of placement of variables in registers. The `register` keyword (which can only be used with `auto` variables) is silently ignored and has no effect on memory allocation of variables.

There are very few registers available for caching of variables on PIC baseline and mid-range devices, and as these registers must be frequently used by generated code for other purposes, there is little advantage in using them. The cost involved in loading variables into registers would far outweigh any advantage of accessing the register. At present, code compiled for PIC18 devices also does not utilize registers other than that described below.

Some arguments are passed to functions in the W register rather than in a memory location; however, these values will typically be stored back to memory by code inside the function so that W can be used by code associated with that function. See [Section 5.8.5 "Function Size Limits"](#) for more information as to which parameter variables can use registers.

## 5.5.7 Dynamic Memory Allocation

Dynamic memory allocation, (heap-based allocation using `malloc`, etc.) is not supported on any 8-bit device. This is due to the limited amount of data memory, and that this memory is banked. The wasteful nature of dynamic memory allocation does not suit itself to the 8-bit PIC device architectures.

## 5.5.8 Memory Models

MPLAB XC8 C Compiler does not use fixed memory models to alter allocation of variables to memory. Memory allocation is fully automatic and there are no memory model controls.

## 5.6 OPERATORS AND STATEMENTS

The MPLAB XC8 C Compiler supports all the ANSI operators. The exact results of some of these are implementation defined. Implementation-defined behavior is fully documented in [Appendix D. Implementation-Defined Behavior](#). The following sections illustrate code operations that are often misunderstood as well as additional operations that the compiler is capable of performing.

### 5.6.1 Integral Promotion

When there is more than one operand to an operator, they typically must be of exactly the same type. The compiler will automatically convert the operands, if necessary, so they do have the same type. The conversion is to a “larger” type so there is no loss of information; however, the change in type can cause different code behavior to what is sometimes expected. These form the standard type conversions.

Prior to these type conversions, some operands are unconditionally converted to a larger type, even if both operands to an operator have the same type. This conversion is called *integral promotion* and is part of Standard C behavior. The compiler performs these integral promotions where required, and there are no options that can control or disable this operation. If you are not aware that the type has changed, the results of some expressions are not what would normally be expected.

Integral promotion is the implicit conversion of enumerated types, *signed* or *unsigned* varieties of *char*, *short int* or bit-field types to either *signed int* or *unsigned int*. If the result of the conversion can be represented by an *signed int*, then that is the destination type, otherwise the conversion is to *unsigned int*.

Consider the following example.

```
unsigned char count, a=0, b=50;
if(a - b < 10)
    count++;
```

The *unsigned char* result of *a - b* is 206 (which is not less than 10), but both *a* and *b* are converted to *signed int* via integral promotion before the subtraction takes place. The result of the subtraction with these data types is -50 (which is less than 10) and hence the body of the *if()* statement is executed.

If the result of the subtraction is to be an *unsigned* quantity, then apply a cast. For example:

```
if((unsigned int)(a - b) < 10)
    count++;
```

The comparison is then done using *unsigned int*, in this case, and the body of the *if()* would not be executed.

Another problem that frequently occurs is with the bitwise complement operator, *~*. This operator toggles each bit within a value. Consider the following code.

```
unsigned char count, c;
c = 0x55;
if( ~c == 0xAA)
    count++;
```

If *c* contains the value 0x55, it is often assumed that *~c* will produce 0xAA; however, the result is 0xFFAA and so the comparison in the above example would fail. The compiler can be able to issue a mismatched comparison error to this effect in some circumstances. Again, a cast could be used to change this behavior.

The consequence of integral promotion as illustrated above is that operations are not performed with `char`-type operands, but with `int`-type operands. However, there are circumstances when the result of an operation is identical regardless of whether the operands are of type `char` or `int`. In these cases, the compiler will not perform the integral promotion so as to increase the code efficiency. Consider this example.

```
unsigned char a, b, c;  
a = b + c;
```

Strictly speaking, this statement requires that the values of `b` and `c` should be promoted to `unsigned int`, the addition performed, the result of the addition cast to the type of `a`, and then the assignment can take place. Even if the result of the `unsigned int` addition of the promoted values of `b` and `c` was different to the result of the `unsigned char` addition of these values without promotion, after the `unsigned int` result was converted back to `unsigned char`, the final result would be the same. If an 8-bit addition is more efficient than a 16-bit addition, the compiler will encode the former.

If, in the above example, the type of `a` was `unsigned int`, then integral promotion would have to be performed to comply with the ANSI C standard.

## 5.6.2 Rotation

The C language does not specify a rotate operator; however, it does allow shifts. The compiler will detect expressions that implement rotate operations using shift and logical operators and compile them efficiently.

For the following code:

```
c = (c << 1) | (c >> 7);
```

if `c` is `unsigned` and `non-volatile`, the compiler will detect that the intended operation is a rotate left of 1 bit and will encode the output using the PIC MCU rotate instructions. A rotate left of 2 bits would be implemented with code like:

```
c = (c << 2) | (c >> 6);
```

This code optimization will also work for integral types larger than a `char`. If the optimization cannot be applied, or this code is ported to another compiler, the rotate will be implemented, but typically with shifts and a bitwise OR operation.

## 5.6.3 Switch Statements

The compiler can encode `switch` statements using one of several strategies. By default, the compiler chooses a strategy based on the case values that are used inside the `switch` statement. Each `switch` statement is assigned its strategy independently.

The type of strategy can be indicated by using the `#pragma switch` directive. See [Section 5.14.4.10 "The #pragma switch Directive"](#), which also lists the available strategy types. There can be more than one strategy associated with each type.

There is information printed in the assembly list file for each `switch` statement detailing the value being switched and the case values listed. See [Section 6.4.4 "Switch Statement Information"](#).

## 5.7 REGISTER USAGE

The assembly generated from C source code by the compiler will use certain registers in the PIC MCU register set. Most importantly, the compiler assumes that nothing other than code it generates can alter the contents of these registers.

So, if compiler-generated assembly code loads a register with a value and no subsequent code requires this register, the compiler will assume that the contents of the register are still valid later in the output sequence.

If any of the applicable registers listed are used by interrupt code, they will be saved and restored when an interrupt occurs, either in hardware or software. See [Section 5.9.4 “Context Switching”](#).

The registers that are special and which are used by the compiler are listed in [Table 5-12](#).

**TABLE 5-12: REGISTERS USED BY THE COMPILER**

Applicable devices	Register name
All 8-bit devices	W
All 8-bit devices	STATUS
All mid-range devices	PCLATH
All PIC18 devices	PCLATH, PCLATU
Enhanced mid-range and PIC18 devices	BSR
Non-enhanced mid-range devices	FSR
Enhanced mid-range and PIC18 devices	FSR0L, FSR0H, FSR1L, FSR1H
All PIC18 devices	FSR2L, FSR2H
All PIC18 devices	TBLPTRL, TBLPTRH, TBLPTRU, TABLAT
All PIC18 devices	PRODL, PRODH
Enhanced mid-range and PIC18 devices	btemp, wtemp, ttemp, ltemp

The `xtemp` registers are variables that the compiler treats as registers. These are saved like any other register if they are used in interrupt code.

The state of these registers must never be changed directly by C code, or by any assembly code in-line with C code. The following example shows a C statement and in-line assembly that violates these rules and changes the ZERO bit in the STATUS register.

```
#include <xc.h>

void getInput(void)
{
    ZERO = 0x1; // do not write using C code
    c = read();
    #asm
        bcf ZERO ; do not write using inline assembly code
    #endasm
    process(c);
}
```

MPLAB XC8 is unable to interpret the register usage of in-line assembly code that is encountered in C code. Nor does it associate a variable mapped over an SFR to the actual register itself. Writing to an SFR register using either of these two methods will not flag the register as having changed and can lead to code failure.

## 5.8 FUNCTIONS

Functions are written in the usual way, in accordance with C language. Implementation and special features associated with functions are discussed in following sections.

### 5.8.1 Function Specifiers

Functions can, in the usual way, use the standard specifier `static`. A function defined using the `static` specifier only affects the scope of the function; i.e., limits the places in the source code where the function can be called. Functions that are `static` can only be directly called from code in the file in which the function is defined. The equivalent symbol used in assembly code to represent the function can change if the function is `static`, see [5.12.3 Interaction between Assembly and C Code](#). This specifier does not change the way the function is encoded. Non-standard qualifiers are discussed below.

#### 5.8.1.1 INTERRUPT SPECIFIER

The `interrupt` specifier indicates that the function is an interrupt service routine and that it is to be encoded specially to suit this task. Interrupt functions are described in detail in [5.9.1 Writing an Interrupt Service Routine](#).

#### 5.8.1.2 INLINE SPECIFIER

The `inline` function specifier is a recommendation that the compiler replace calls to the specified function with the function's body, if possible.

The following is an example of a function which has been made a candidate for inlining.

```
inline int combine(int x, int y) {  
    return 2*x-y;  
}
```

All function calls to any function that were inlined by the compiler will be encoded as if the call was replaced with the body of the called function. This is performed at the assembly code level. Inlining will only take place if the assembly optimizers are enabled and the compiler is not operating in Free mode. The function itself might still be encoded normally by the compiler even if it is inlined.

If inlining takes place, this will increase the program's execution speed, since the call and return sequences associated with the call will be eliminated. It will also reduce the hardware stack usage as no call instruction is actually executed; however, this reduction is not reflected in the call graphs as this is generated before inlining takes place. Code size can be reduced if the assembly code associated with the body of the inlined function is very small, but code size can increase if the body of the inlined function is larger than the call/return sequence it replaces. You should only consider this specifier for functions which generate small amounts of assembly code. Note that the amount of C code in the body of a function is not a good indicator of the size of the assembly code that it generates (see [Section 3.6.13 "How Can I Tell How Big a Function Is?"](#)).

A function containing in-line assembly will not be inlined. Some generated assembly code sequences will also prevent inlining of a function. A warning will be generated if the `inline` function references `static` objects (to comply with the ANSI Standard) or is not inlined successfully. Your code should not make any assumption about whether inlining was successful.

This specifier performs the same task as the `#pragma inline` directive, see [Section 5.14.4.4 "The #pragma Intrinsic Directive"](#).

Note that the optimizers can also implicitly inline small called-only-once routines, see [Section 6.3 "Assembly-Level Optimizations"](#).

## 5.8.1.3 REENTRANT AND NONREENTRANT SPECIFIERS

The `reentrant` and `nonreentrant` function specifiers indicate the function model (stack) that should be used for that function's stack-based variables (`auto`, parameter, and temporary variables), as shown in [Table 5-13](#). The aliases `software` and `compiled`, respectively, can also be used. If the `--STRICT` option has been enabled (see [Section 4.8.60 "--STRICT: Strict ANSI Conformance"](#)) these specifiers must use two leading underscore characters, (e.g., `__reentrant`).

**TABLE 5-13: STACK RELATED FUNCTION SPECIFIERS**

Specifier	Allocation for Stack-based variables
<code>compiled, nonreentrant</code>	Always use the compiled stack; functions are non-reentrant.
<code>software, reentrant</code>	Use the software stack, if available; functions are reentrant.

You would only use these specifiers if the default allocation of a function's stack-based variables is unacceptable. These specifiers override any setting indicated using the `--STACK` option, see [Section 4.8.59 "--STACK: Specify Data Stack Type For Entire Program"](#). If no specifier or `--STACK` option has been used, all functions are encoded as non-reentrant and use the compiled stack.

The following shows an example of a function that will always be encoded as reentrant.

```
reentrant int setWriteMode(int mode)
{
    if(mode != 3)
        mode = 0;
    return mode;
}
```

The `reentrant` specifier only has an effect if the target device supports a software stack. In addition, not all functions allow reentrancy. Interrupt functions must always use the compiled stack, but functions they call may use the software stack. Functions encoded for baseline and mid-range devices always use the non-reentrant model and the compiled stack.

Repeated use of the `software (reentrant)` specifier will increase substantially the size of the software stack leading to possible overflow. The size of the software stack is not accurately known at compile time, so the compiler cannot issue a warning if it is likely to overwrite memory used for some other purpose. The stack may overwrite other sections of the program in data memory, or memory used by something outside the program, such as hardware or another independently-compiled application.

See [Section 5.3.4.2 "Data Stacks"](#) for device specific information relating to the data stacks available on each device.

## 5.8.2 External Functions

If a call is made to a function that is defined outside the program's C source code (e.g., a function defined in a separate bootloader project), you will need to provide a declaration of the function so that the compiler knows how to encode the call. If this function takes arguments or returns a value, you might need to define a symbol to represent the memory locations used to store these values. See [Section 5.8.6 "Function Parameters"](#) and [Section 5.8.7 "Function Return Values"](#) to determine if a register or memory locations are used in this transfer. If this symbol is not defined, the compiler will issue an undefined symbol error. This error can be used to verify the name being used by the compiler to encode the call, if required.

The required value can be determined from the map file of the external build. Look for the symbol `?_funcName`, where `funcName` is the name of the function defined externally. Define this symbol in your code that makes the call via a simple `EQU` directive in assembler. For example, the following snippet of code could be placed in your C source to allow you to call the function `extReadFn()` defined in another project:

```
#asm
GLOBAL ?_extReadFn
?_extReadFn EQU 0x20
#endasm
```

This defines the base address of the parameter area for `extReadFn()` to be `0x20`.

It is not recommended to call the function indirectly by casting an integer to a function pointer, but in such a circumstance, the compiler will use the value of the constant in the symbol name; for example, calling a function at address `0x200` will require the definition of the symbol `?0x200` to be the location of the parameter/return value location for the function. For example:

```
#asm
GLOBAL ?0x200
?0x200 EQU 0x55
#endasm
```

Note that the return value of a function (if used) shares the same locations assigned to any parameters to that function and both use the same symbol.

If an external function uses the reentrant model, it will never use the `W` register for parameter passing. All arguments are stored on the stack.



## 5.8.3 Allocation of Executable Code

Code associated with functions is always placed in the program memory of the target device.

On baseline and mid-range devices, the program memory is paged (compare: banking used in the data memory space). This memory is still sequential (addresses are contiguous across a page boundary), but the paging means that any call or jump from code in one page to a label in another must use a longer sequence of instructions to accomplish this. See your device data sheet for more information on the program memory and instruction set.

PIC18 devices do not implement any program memory paging. The `CALL` and `GOTO` instruction are two-word instructions and their destinations are not limited. The relative branch instructions have a limited range, but this is not based on any paging boundaries.

The generated code associated with each function is initially placed in its own psect by the compiler, see [Section 5.15.1 “Program Sections”](#). These psects have names such as `textn`, where `n` is a number, e.g., `text98`. However, psects can be merged later in the compilation process so that more than one function can contribute to a psect.

When the program memory is paged, functions within the same psect can use a shorter form of call and jump to labels so it is advantageous to merge the code for as many functions into the same psect. These text psects are linked anywhere in the program memory (see [5.10 Main, Runtime Startup and Reset](#)).

If the size of a psect that holds the code associated with a function exceeds the size of a page, it can be split by the assembler optimizer. A split psect will have a name of the form `textn_split_s`. So, for example, if the `text102` psect exceeds the size of a page, it can be split into a `text102_split_1` and a `text102_split_2` psect. This process is fully automatic, but you should be aware that if the code associated with a function does become larger than one page in size, the efficiency of that code can drop fractionally due to any longer jump and call instruction sequences being used to transfer control to code in other pages.

The base name of each psect category is tabulated below. A full list of all program-memory psect names are listed in [Section 5.15.2.1 “Program Space Psects”](#).

<b><code>maintext</code></b>	The generated code associated with the special function, <code>main</code> , is placed in this psect. Some optimizations and features are not applied to this psect.
<b><code>textn</code></b>	These psects (where <code>n</code> is a decimal number) contain all other executable code that does not require a special link location.

## 5.8.4 Changing the Default Function Allocation

You can change the default memory allocation of functions by either:

- Reserving memory locations
- Making functions absolute; or
- Placing functions in their own section and linking that section

If you don't want functions (or any other program memory object) to be placed in certain memory ranges, reserve those ranges using the `--ROM` memory option, see [Section 4.8.53 "--ROM: Adjust ROM Ranges"](#).

The easiest method to explicitly place individual functions at a known address is to make them absolute functions by using the `@ address` construct in a similar fashion to that used with absolute variables.

The compiler will issue a warning if code associated with an absolute function overlaps with code from other absolute functions. No warning will be issued if the address of an absolute object lies outside the memory of the device or outside the memory defined by the linker classes. The compiler will not locate code associated with ordinary functions over the top of absolute functions.

The following example of an absolute function will place the function at address 400h:

```
int mach_status(int mode) @ 0x400
{
    /* function body */
}
```

If this construct is used with interrupt functions, it will only affect the position of the code associated with the interrupt function body. The interrupt context switch code associated with the interrupt vector will not be relocated. See also [Section 4.8.21 "--CODEOFFSET: Offset Program Code to Address"](#), for information on how to move Reset and interrupt vector locations (which can be useful for designing applications such as bootloaders).

The code generated for absolute functions is placed in a psect dedicated only to that function. The psect name has the form shown below. A full list of all psect names are listed in [Section 5.15.2 "Compiler-Generated Psects"](#).

**xxx\_text** Defines the psect for a function that has been made absolute. `xxx` will be the assembly symbol associated with the function, e.g., the absolute function `rv()` would appear in the psect called `_rv_text`.

Functions can be allocated to a user-defined psect using the `__section()` specifier (see [Section 5.15.4 "Changing and Linking the Allocated Section"](#)) so that this new psect can then be linked at the required location. This method is the most flexible and allows functions to be placed at a fixed address, after other psects, or anywhere in an address range. As with absolute functions, when used with interrupt functions, it will only affect the position of the interrupt function body. Never place functions into a psect that is also used to hold non-executable objects, such as `const` objects, as this might affect the ability to debug the functions.

Regardless of *how* a function is located, take care choosing its address. If possible, place functions at either end of a program memory page to avoid fragmenting memory and increasing the possibility of linker errors. Note that the compiler imposes pseudo page boundaries on some PIC18 devices to work around published errata. Place functions in the first page, which contains the reset and interrupt code, rather than in pages higher in memory, as this will assist the optimizations that merge psects.

## 5.8.5 Function Size Limits

For all devices, the code generated for a regular function is limited only by the available program memory. Functions can become larger than one page in size on paged devices, but the longer call sequences to other pages decrease efficiency. See [5.8.3 Allocation of Executable Code](#) for more details.

Interrupt functions (see [Section 5.9.1 “Writing an Interrupt Service Routine”](#)) however, are limited to one page in size and cannot be split over multiple pages.

## 5.8.6 Function Parameters

MPLAB XC8 uses a fixed convention to pass arguments to a function. The method used to pass the arguments depends on the size and number of arguments involved, and on which stack model is used with the function.

**Note:** The names “argument” and “parameter” are often used interchangeably, but typically an argument is the actual value that is passed to the function and a parameter is the variable defined by the function to store the argument.

### 5.8.6.1 COMPILED STACK PARAMETERS

For functions using the non-reentrant model, the compiler will either pass arguments in the W register, or in the called function’s parameter memory. If the first parameter is one byte in size, it is passed in the W register. All other parameters are passed in the parameter memory. This applies to basic types and to aggregate types, like structures.

The parameters are grouped along with the function’s `auto` variables in the parameter memory, and are placed in the compiled stack. See [Section 5.5.2.2.1 “Compiled Stack Operation”](#), for detailed information on the compiled stack. The parameter variables will be referenced as an offset from the symbol `?_function`, where `function` is the name of the function in which the parameter is defined (i.e., the function that is to be called).

Unlike `auto` variables, parameter variables are allocated memory strictly in the order in which they appear in the function’s prototype. This means that the parameters will always be placed in the same memory bank. The `auto` variables for a function can be allocated across multiple banks and in any order.

The parameters for variadic functions that take a variable argument list (defined using an *ellipsis* in the prototype and which are called non-prototyped parameters) are placed in the parameter memory, along with named parameters.

Take, for example, the following ANSI-style function.

```
void test(char a, int b);
```

The function `test()` will receive the parameter `b` in its function auto-parameter block and `a` in the `w` register. A call to this function:

```
test(xyz, 8);
```

would generate code similar to:

```
MOVLW    08h        ; move literal 0x8 into...
MOVWF    ?_test     ; the auto-parameter memory
CLRF     ?_test+1   ; locations for the 16-bit parameter
MOVF     _xyz,w     ; move xyz into the W register
CALL     (_test)
```

In this example, the parameter `b` is held in the memory locations `?_test` (LSB) and `?_test+1` (MSB).

The compiler needs to take special action if more than one function can be indirectly called via the same function pointer. Such would be the case in the following example, where any of `sp_ad`, `sp_sub` or `sp_null` could be called via the pointer, `fp`.

```
int (*funcs[])(int, int) = {sp_add, sp_sub, sp_null};
int (*fp)(int, int);
fp = funcs[getOperation()];
result = fp(37, input);
```

In such a case, the compiler treats all three functions referenced in the array as being “buddies”.

The parameter variable(s) to all buddy functions will be aligned in memory, i.e., they will all reside at the same address(es). This way the compiler does not need to know exactly which function is being called, which is often the case. The implication of this is that a function cannot call (either directly or indirectly) any of its buddies. To do so would corrupt the caller function's parameter variables. An error will be issued if such a call is attempted. This restriction does not apply to similar functions that use the software stack (see [Section 5.8.6.2 “Software Stack Parameters”](#)).

The exact code used to call a function, or the code used to access parameters from within a function, can always be examined in the assembly list file. See [Section 4.8.16 “--ASMLIST: Generate Assembler List Files”](#) for the option that generates this file. This is useful if you are writing an assembly routine that must call a function with parameters, or accept arguments when it is called. The above example does not consider data memory banking or program memory paging, which can require additional instructions.

## 5.8.6.2 SOFTWARE STACK PARAMETERS

When a function uses the reentrant model, most arguments to that function will be passed on the software stack. Parameters placed on the software stack are pushed in the reverse order to which they were defined in the called function's prototype. This is unlike `auto` variables, which may be allocated memory in any order.

The `w` register is sometimes used for the first function argument if it is byte-sized and the function uses the reentrant model. This will only take place for enhanced mid-range devices and provided the function is not variadic and returns a value in `btemp` registers (see [Section 5.8.7.2 “Software Stack Return Values”](#) [Section 5.8.7.2 “Software Stack Return Values”](#)). If a reentrant function is external (see [Section 5.8.2 “External Functions”](#)), the `W` register will never be used to store any function arguments. The `w` register is never used by reentrant function arguments when compiling for PIC18 devices.

For variadic functions, which take a variable argument list (defined using an *ellipsis* in the prototype), the unprototyped parameters are placed on the software stack, before the named parameters. After all the function's arguments have been pushed, the total size of the non-prototyped parameters is pushed on to the stack (except if this function has a return value which is returned on the stack). A maximum of 256 bytes of non-prototyped parameters are permitted per function.

Recall that the function return address is not stored on this data stack. It is automatically stored on the hardware stack by the device, see [Section 5.3.4.1 “Function Return Address Stack”](#).

As there is no frame pointer, accessing function parameters, or other stack-based objects, is not recommended in hand-written assembly code.

## 5.8.7 Function Return Values

Values returned from functions are loaded into a register or placed on the stack used by that function. The mechanism will depend on the function model used by the function.

### 5.8.7.1 COMPILED STACK RETURN VALUES

For functions that use the non-reentrant model, return values are passed to the calling function using the `w` register, or the function's parameter memory. Re-using the memory used by the parameters (which is no longer needed when the function is ready to return) can reduce the code and data requirements for functions.

Eight-bit values are returned from a function in the `w` register. Values larger than a byte are returned in the function's parameter memory area, with the least significant word (`lsw`) in the lowest memory location.

For example, the function:

```
int return_16(void)
{
    return 0x1234;
}
```

will exit with the code similar to:

```
MOVLW 34h
MOVWF (?_return_16)
MOVLW 12h
MOVWF (?_return_16)+1
RETURN
```

For PIC18 targets returning values greater than 4 bytes in size, the address of the parameter area is also placed in the `FSR0` register.

Functions that return a bit do so using the carry bit of the `STATUS` register.

### 5.8.7.2 SOFTWARE STACK RETURN VALUES

Functions that use the reentrant model will pass values back to the calling function via `btemp` variables, provided the value is 4 bytes or less in size. The `w` register will be used to return byte-sized values for enhanced mid-range device functions that are not variadic. For objects larger than 4 bytes in size, they are returned on the stack. Reentrant PIC18 functions that return a `bit` do so using bit #0 in `btemp0`; other devices use the carry bit in the `STATUS` register.

As there is no frame pointer, accessing the return value location, or other stack-based objects, is not recommended in hand-written assembly code.

## 5.8.8 Calling Functions

All 8-bit devices use a hardware stack for function return addresses. The depth of this stack varies from device to device.

Typically, `CALL` assembly instructions are used to transfer control to a C function when it is called. Each function call uses one level of stack. This stack level is freed after the called routine executes a `RETURN` instruction. The stack usage grows if a called function calls another before returning. If the hardware stack overflows, function return addresses will be destroyed and the code will eventually fail.

The `stackcall` suboption to the `--RUNTIME` option controls how the compiler behaves when the compiler detects that the hardware stack is about to overflow due to too many nested calls. See [Section 4.8.54 “--RUNTIME: Specify Runtime Environment”](#) for details on this option. If this suboption is disabled (the default state), where the depth of the stack will be exceeded by a call, the compiler will issue a warning to indicate that this is the case. For PIC18 devices, this is the only way in which calls are made, but for other 8-bit devices, the compiler can swap to an alternate way of making calls, as detailed below.

If the `stackcall` suboption is enabled, the compiler will, instead of issuing a warning, automatically swap to using a method that involves the use of a lookup table and which does not require use of the hardware stack. This managed stack feature is not available for PIC18 devices.

When the lookup method is being employed, a function is reached by a jump (not a call) directly to its address. Before this is done the address of a special “return” instruction (implemented as a jump instruction) is stored in a temporary location inside the called function. This return instruction will be able to return control back to the calling function.

This means of calling functions allows functions to be nested deeply without overflowing the limited stack available on baseline and mid-range devices; however, it does come at the expense of memory and program speed.

### 5.8.8.1 INDIRECT CALLS

When functions are called indirectly using a pointer, the compiler employs a variety of techniques to call the intended function.

The PIC18 and enhanced mid-range devices all use the value in the function pointer to load the program counter with the appropriate address. For PIC18 devices, the code loads the TOS registers and executes a `RETURN` to perform the call. For enhanced mid-range devices, the `CALLW` instruction is used. The number of functions that can be called indirectly is limited only by the available memory of the device.

The baseline and mid-range devices all use a lookup table which is loaded with jump instructions. The lookup table code is called and an offset is used to execute the appropriate jump in the table. The table increases in size as more functions are called indirectly, but cannot grow beyond 0xFF bytes in size. This places a limit on the number of functions that can be called indirectly, and typically this limit is approximately 120 functions. Note that this limit does not affect the number of function pointers a program can define, which are subject to the normal limitations of available memory on the device.

Indirect calls are not affected by the `stackcall` suboption to the `--RUNTIME` option and the depth of indirect calls on baseline and mid-range devices are limited by the hardware stack depth.

## 5.8.8.2 BANK SELECTION WITHIN FUNCTIONS

A function can return with any RAM bank selected. See [Section 5.5.1 “Address Spaces”](#) for more information on RAM banks.

The compiler tracks the bank selections made in the generated code associated with each function, even across function calls to other functions. If the bank that is selected when a function returns can be determined, the compiler will use this information to try to remove redundant bank selection instructions which might otherwise be inserted into the generated code.

The compiler will not be able to track the bank selected by routines written in assembly, even if they are called from C code. The compiler will make no assumptions about the selected bank when such routines return.

The “Tracked objects” section associated with each function, and which is shown in the assembly list file, relates to this bank tracking mechanism. See [6.3 Assembly-Level Optimizations](#) for more information of the content of these files.

## 5.9 INTERRUPTS

The MPLAB XC8 compiler incorporates features allowing interrupts to be fully handled from C code. Interrupt functions are often called Interrupt Service Routines, or ISRs.

The operation of interrupts is handled differently by the different device families. Most baseline devices do not implement interrupts at all; mid-range devices have one vector location which is linked to all interrupt sources; some PIC18 devices have two independent interrupt vectors, one assigned to low-priority interrupt sources, the other to high-priority sources; and, finally, some PIC18 devices implement an interrupt controller macro (ICM) module with support for one or more interrupt vector tables (IVTs), which can be populated with the addresses of high- or low-priority interrupt functions.

The operation of the IVT on devices with an ICM can be disabled by clearing the `MVECEN` configuration bit. The device is then said to be operating in *legacy mode*, and will operate with dual priorities and dual vector locations. Although the vector table is disabled in this mode, the vector locations are still relocatable. By default the vector location will be 0x8 and 0x18, the same for regular PIC18 devices without the ICM.

The priority scheme implemented by PIC18 devices can also be disabled by clearing the `IPEN` SFR bit. Such devices are then said to be operating in *mid-range compatibility mode* and utilize only one interrupt vector, located at address 0x8.

The following are the general steps you need to follow to use interrupts. More detail about these steps is provided in the sections that follow.

For enhanced baseline devices with interrupts, mid-range devices, or PIC18 devices operating in mid-range compatibility mode:

- Write one interrupt function to process all interrupt sources.
- At the appropriate point in your main-line code, unmask the interrupt sources required by setting their interrupt enable bit in the corresponding SFR.
- At the appropriate point in your code, enable the global interrupt enable to allow interrupts to be generated.

For PIC18 devices without the ICM module, or PIC18 devices operating in legacy mode:

- Plan the priorities to be assigned to each interrupt source. If the device is operating in legacy mode, determine the number of interrupt vector tables you require.
- Write one interrupt function to process each priority being used. You can define at most two interrupt functions, or two interrupt functions per vector table for devices operating in legacy mode. Consider implementing both interrupt functions to handle accidental triggering of unused interrupts, or use the `--UNDEFINTS` option to provide a default action, see [Section 4.8.63 “--UNDEFINTS: Program Unused Interrupt Vectors”](#).
- Write code to assign the required priority to each interrupt source by writing the appropriate bits in the SFRs.
- If the device is operating in legacy mode and if required, at the appropriate points in your code, select the required IVT by writing to the `IVTBASE` registers. Never write the `IVTBASE` registers if interrupts are enabled. The initial IVT can also be selected by using the `ivt` sub-option to the `--RUNTIME` option, see [Section 4.8.54 “--RUNTIME: Specify Runtime Environment”](#).
- At the appropriate point in your code, enable the interrupt sources required.
- At the appropriate point in your code, enable the global interrupt enable.



For devices using the Interrupt Controller Macro module:

- Plan the priorities associated with each interrupt source, and determine the number of interrupt vector tables you require.
- Write as many interrupt functions as required. For fast interrupt response times, write a dedicated function for each interrupt source, although multiple sources can be processed by one function, if desired. Consider one or more additional functions to handle accidental triggering of unused interrupt sources, or use the `--UNDEFINTS` option to provide a default action, see [Section 4.8.63 “--UNDEFINTS: Program Unused Interrupt Vectors”](#).
- Write code to assign the required priority to each interrupt source by writing the appropriate bits in the SFRs.
- If you are using more than one interrupt vector table, at the appropriate points in your code, select the required IVT by writing to the `IVTBASE` registers. Never write the `IVTBASE` registers if interrupts are enabled. The initial IVT can also be selected by using the `ivt` sub-option to the `--RUNTIME` option, see [Section 4.8.54 “--RUNTIME: Specify Runtime Environment”](#).
- At the appropriate point in your code, enable the interrupt sources required.
- At the appropriate point in your code, enable the global interrupt enable.

Interrupt functions must not be called directly from C code (due to the different return instruction that is used), but interrupt functions can call other functions, both user-defined and library functions.

*Interrupt code* is the name given to any code that executes as a result of an interrupt occurring, including functions called from the ISR and library code. Interrupt code completes at the point where the corresponding return from interrupt instruction is executed. This contrasts with *main-line code*, which, for a freestanding application, is usually the main part of the program that executes after Reset.

## 5.9.1 Writing an Interrupt Service Routine

The prototype and content of an ISR will vary based on the target device and the project being compiled. Observe the following guidelines when writing an ISR.

For devices that do not have the ICM module:

- Write each ISR prototype using either the `interrupt` or `__interrupt()` specifiers.
- Use `void` as the return type and for the parameter specification.
- If your device supports interrupt priorities, with each function use the `low_priority` or `high_priority` arguments to `__interrupt()`, or use these as stand-alone specifiers with `interrupt`.
- Inside the ISR body, determine the source of the interrupt by checking the interrupt flag and the interrupt enable for each source that is to be processed, and make the relevant interrupt code conditional on those being set.

For devices operating in legacy mode:

- Write each ISR prototype using either the `interrupt` or `__interrupt()` specifiers.
- Use `void` as the return type, and specify a parameter list of either `void` or one `char` argument if you need to identify the interrupt source.<sup>1</sup>
- As arguments to the `__interrupt()` specifier in the ISR prototype, specify the interrupt priority assigned to the function's source, using `low_priority` or `high_priority`; and optionally, specify the base address of the IVT in which to

---

<sup>1</sup>. It is recommended that the parameter list be set to `void` if you want to ensure portability with devices that do not have the ICM module.

place the function's address, using `base()`.<sup>1</sup>

- If the ISR processes more than one source, determine the source of the interrupt from the function's parameter, if specified, or by checking the interrupt flag and the interrupt enable for each source that is to be processed.

For devices which are using the ICM module:

- Write each ISR prototype using only the `__interrupt()` specifier.
- Use `void` as the return type, and specify a parameter list of either `void` or one `char` argument if you need to identify the interrupt source.
- As arguments to the `__interrupt()` specifier in the ISR prototype, specify which sources each interrupt function should handle, using `irq()`; specify the interrupt priority assigned to the function's source, using `low_priority` or `high_priority`; and optionally, specify the base address of the IVT in which to place the function's address, using `base()`.
- If the ISR processes more than one source, determine the source of the interrupt from the function's parameter, if specified, or by checking the interrupt flag and the interrupt enable for each source that is to be processed.

For all devices:

- Inside the ISR body, clear the relevant interrupt flag once the source has been processed.
- Do not re-enable interrupts inside the ISR body. This is performed automatically when the ISR returns.
- Keep the ISR as short and as simple as possible. Complex code will typically use more registers that will increase the size of the context switch code.

When the `xc8` option `--STRICT` is enabled, the `interrupt` specifier should be written as `__interrupt`. (Note the difference between this and the `__interrupt()` specifier which uses brackets.)

If interrupt priorities are being used but an ISR does not specify a priority, it will default to being high priority. It is recommended that you always specify the ISR priority to ensure your code is readable.

If you use the `__interrupt()` specifier with a device that does not have the ICM, supplying an `irq()` or `base()` argument will result in an error from the compiler. If you use this specifier with a device that is configured for legacy mode, supplying an `irq()` argument will result in an error from the compiler; however, you may continue to use the `base()` argument if required.

Devices that have the ICM module identify each interrupt with a number. This number can be specified with the `irq()` argument to `__interrupt()` if the vector table is enabled, or you can use a compiler-defined symbol that equates to that number. You can see a list of all interrupt numbers, symbols and descriptions by opening the files `pic_chipinfo.html` or `pic18_chipinfo.html` in your favorite web browser, and selecting your target device. Both these files are located in the DOCS directory under your compiler's installation directory.

Interrupt functions always use the non-reentrant function model. These functions ignore any option or function specifier that might otherwise specify reentrancy.

The compiler will process interrupt functions differently to other functions, generating code to save and restore any registers used by the function and using a special instruction to return.

---

<sup>1</sup>. It is recommended that the base address be left as the default if you want to ensure portability with devices that do not have the ICM module.

An example of an interrupt function written for code not using the IVT is shown below. Notice that the interrupt function checks for the source of the interrupt by looking at the interrupt enable bit (e.g., `TMR0IE`) and the interrupt flag bit (e.g., `TMR0IF`). Checking the interrupt enable flag is required since interrupt flags associated with a peripheral can be asserted even if the peripheral is not configured to generate an interrupt.

```
int tick_count;

void high_priority interrupt tcInt(void)
{
    if (TMR0IE && TMR0IF) { // any timer 0 interrupts?
        TMR0IF=0;
        ++tick_count;
    }
    if (TMR1IE && TMR1IF) { // any timer 1 interrupts?
        TMR1IF=0;
        tick_count += 100;
    }
    // process other interrupt sources here, if required
    return;
}
```

Here is the same function code, split and modified for a device using vector tables. Note that since only one source is associated each ISR, the interrupt code does not need to determine the source of the interrupt and is therefore faster.

```
void __interrupt(irq(TMR0),high_priority) tc0Int(void)
{
    TMR0IF=0;
    ++tick_count;
    return;
}

void __interrupt(irq(TMR1),high_priority) tc1Int(void)
{
    TMR1IF=0;
    tick_count += 100;
    return;
}
```

If you prefer to process multiple interrupt sources in one function, that can be done by specifying more than one interrupt source in the `irq()` argument and using a function parameter to hold the source number, such as in the following example.

```
void __interrupt(irq(TMR0,TMR1),high_priority) tInt(unsigned char src)
{
    switch(src) {
        case IRQ_TMR0:
            TMR0IF=0;
            ++tick_count;
            break;
        case IRQ_TMR1:
            TMR1IF=0;
            tick_count += 100;
            break;
    }
    return;
}
```

The ICM module will load the parameter, in this example, `src`, with the interrupt source number when the interrupt occurs.

The special interrupt source symbol, `default`, can be used to indicate that the ISR will be linked to any interrupt vector not already explicitly specified using `irq()`. You can also populate unused vector locations by using the `--UNDEFINTS` option, see [Section 4.8.63 “--UNDEFINTS: Program Unused Interrupt Vectors”](#).

By default, the interrupt vector table will be located at an address equal to the reset value of the IVTBASE register, which is the legacy address of 0x8. The `base()` argument to `__interrupt()` can be used to specify a different table base address for that function. This argument can take one or more comma-separated addresses. The base address cannot be set to an address lower than the reset value of the IVTBASE register.

By default and if required, the compiler will initialize the IVTBASE register in the runtime startup code. You can disable this functionality by turning off the `ivt` sub-option to the `--RUNTIME` option, see [Section 4.8.54 “--RUNTIME: Specify Runtime Environment”](#). This sub-option also allows you to specify an initial address for this register, hence for the initial vector table that will be used. If vectored interrupts are enabled but you do not specify an address using this option, the vector table location will be set to the lowest table address used in the program, as specified by the `base()` arguments to `__interrupt()`.

If you use the `base()` argument to implement more than one table of interrupt vectors, you must ensure that you allocate sufficient memory for each table. The compiler will emit an error message if it detects an overlap of any interrupt vectors.

The following examples show the interrupt function prototypes for two ISRs which handle the timer 0 and 1 interrupt sources. These are configured to reside in independent vector tables whose base addresses are 0x100 and 0x200. All other interrupt sources are handled by a low-priority ISR, `defIsr()`, which appears in both vector tables. For these ISRs to become active, the IVTBASE register must first be loaded either 0x100 or 0x200. Changing the address in this register allows you to select which vector table is active.

```
void __interrupt(irq(TMR0,TMR1),base(0x100)) timerIsr(void)
{...}
void __interrupt(irq(TMR0,TMR1),base(0x200)) altTimerIsr(void)
{...}
void __interrupt(irq(default),base(0x100,0x200),low_priority)
defIsr(void)
{...}
```

## 5.9.2 Changing the Default Interrupt Function Allocation

Moving the code associated with interrupt functions is more difficult than that for ordinary functions, as interrupt routines have entry points strictly defined by the device.

You can use the `__section()` specifier (see [Section 5.15.4 “Changing and Linking the Allocated Section”](#)) if you want to move the interrupt function, but leave the interrupt entry point at the default vector location.

To move the vector location, see [Section 5.9.3 “Specifying the Interrupt Vector”](#).

## 5.9.3 Specifying the Interrupt Vector

For devices that do not have the ICM module, the process of populating the interrupt vector locations is fully automatic. The compiler links the interrupt code entry point to the fixed vector locations. Typically the entry point code will be all or part of the code that performs the interrupt context switch, and the body of the interrupt function will be located elsewhere.

The location of these interrupt vectors cannot be changed at runtime, nor can you change the code linked to the vector. That is, you cannot have alternate interrupt functions and select which will be active during program execution. An error will result if there are more interrupt functions than interrupt vectors in a program.

For devices that have the ICM module, you have more freedom in how interrupt functions can be executed at runtime. When the IVT is enabled, these devices employ a table of interrupt vectors. Each table entry can hold an address, which is read when the corresponding interrupt is triggered, and the device will jump to that address. The vector table entry corresponding to an interrupt function is automatically completed by the compiler, based on the information in the `irq()` and `base()` arguments to `__interrupt()`, see [Section 5.9.1 “Writing an Interrupt Service Routine”](#).

Although the addresses in the vector table cannot be changed at runtime, it is possible to construct more than one table and have the device swap from one table to another. Changing the active vector table is performed by changing the vector table base address, which is stored in the IVTBASE registers. Since these registers cannot be modified atomically, you must disable all interrupts before changing their content. The following example shows how this might be performed in C code.

```
di();    // disable all interrupts
IVTBASEU = 0x0;
IVTBASEH = 0x2;
IVTBASEL = 0x0;
ei();    // re-enable interrupts
```

If a device with the ICM module is operating in legacy mode, the vector table is disabled and the dual priority vectors employed by regular PIC18 devices are used. These vector locations will then hold an instruction, not an address, but unlike regular PIC18 devices, the device can still use the IVTBASE register to remap the vector locations to any address and you can define an additional two interrupt functions for each table.

Do not confuse the operation of the IVTBASE register with the `--CODEOFFSET` option, see [Section 4.8.21 “--CODEOFFSET: Offset Program Code to Address”](#). This option moves the entry point of the code associated with each interrupt but does not move the vector location. When using this option, your program will not execute correctly until you provide code which remaps the vector locations to the shifted interrupt entry points. By comparison, adjusting the IVTBASE registers does not move the location of the interrupt functions, but changes the vector locations. Your project code will continue to operate normally after adjusting this register.

Interrupt vectors that have not been specified explicitly in the project can be assigned a default function address by defining an interrupt function that uses `default` as its `irq()` interrupt source, or assigned a default instruction by using the `--UNDEFINTS` option, see [Section 4.8.63 “--UNDEFINTS: Program Unused Interrupt Vectors”](#).

## 5.9.4 Context Switching

### 5.9.4.1 CONTEXT SAVING ON INTERRUPTS

Some registers are automatically saved by the hardware when an interrupt occurs. Any registers or compiler temporary objects used by the interrupt function, other than those saved by the hardware, must be saved in code generated by the compiler. This is the *context save* or *context switch* code.

See [Section 5.7 “Register Usage”](#) for the registers that must be saved and restored either by hardware or software when an interrupt occurs.

Enhanced mid-range PIC devices save the W, STATUS, BSR and FSRx registers in hardware (using special shadow registers) and hence these registers do not need to be saved by software. The registers that might need to be saved by software are the BTEMP registers<sup>1</sup>, compiler temporary locations that acts like registers.

Other mid-range PIC processors only save the entire PC (excluding the PCLATH register) when an interrupt occurs. The W, STATUS, FSR and PCLATH registers and any BTEMP registers must be saved by code produced by the compiler, if required.

By default, the PIC18 high-priority interrupt function will utilize its internal shadow register to save the W, STATUS and BSR registers. For the low priority PIC18 interrupts, or when the shadow registers cannot be used, all registers that has been used by the interrupt code will be saved by software.

If the PIC18 device has the Interrupt Controller Macro module, it additionally saves the FSRx, PCLATHx, and PRODX registers to shadow registers. All other used registers are saved in software. Separate shadow registers are available for low- and high-priority interrupts.

Note that for some older devices, the compiler will not use the shadow registers if compiling for the MPLAB ICD debugger, as the debugger itself utilizes these shadow registers. Some errata workarounds also prevent the use of the shadow registers see [Section 4.8.27 “--ERRATA: Specify Errata Workarounds”](#).

The compiler determines exactly which registers and objects are used by an interrupt function, or any of the functions that it calls (based on the call graph generated by the compiler), and saves these appropriately.

Assembly code placed in-line within the interrupt function is *not* scanned for register usage. Thus, if you include in-line assembly code into an interrupt function, you can have to add extra assembly code to save and restore any registers or locations used. The same is true for any assembly routines called by the interrupt code.

If the W register is to be saved by the compiler, it can be stored to memory reserved in the common RAM. If the device for which the code is written does not have common memory, a byte is reserved in all RAM banks for the storage location for W register.

Most registers to be saved are allocated memory in the interrupt function's `auto` area. They can be treated like any other `auto` variable and use the same assembly symbols. On mid-range devices, the W register is stored in BTEMP0, a pseudo register, see [Section 5.7 “Register Usage”](#).

If the software stack is in use, the context switch code will also initialize the stack pointer register so it is accessing the area of the stack reserved for the interrupt. See [Section 5.5.2.2.2 “Software Stack Operation”](#), for more information on the software stack.

---

1. These registers are memory locations allocated by the compiler, but are treated like registers for code generation purposes. They are typically used when generating reentrant code.

## 5.9.4.2 CONTEXT RESTORATION

Any objects saved by software are automatically restored by software before the interrupt function returns. The order of restoration is the reverse of that used when context is saved.

If the software stack is in use, the context restoration code will also restore the stack pointer register so that it is accessing the area of the stack used before the interrupt occurred. See [Section 5.5.2.2.2 “Software Stack Operation”](#) for more information on the software stack.

## 5.9.5 Enabling Interrupts

Two macros are available, once you have included `<xc.h>`, that control the masking of all available interrupts. These macros are `ei()`, which enable or unmask all interrupts, and `di()`, which disable or mask all interrupts.

On all devices, they affect the GIE bit in the INTCON register. These macros should be used once the appropriate interrupt enable bits for the interrupts that are required in a program have been enabled.

For example:

```
ADIE = 1; // A/D interrupts will be used
PEIE = 1; // all peripheral interrupts are enabled
ei();    // enable all interrupts
// ...
di();    // disable all interrupts
```

**Note:** Never re-enable interrupts inside the interrupt function itself. Interrupts are automatically re-enabled by hardware on execution of the `RETFIE` instruction. Re-enabling interrupts inside an interrupt function can result in code failure.

## 5.9.6 Accessing Objects From Interrupt Routines

Reading or writing globally accessible objects from interrupt routines can be unsafe.

The compiler will automatically mark as `volatile` any globally accessible variables that are referenced in an interrupt routine; however, it is recommended that you explicitly mark these variables using the `volatile` specifier to ensure your code is portable, see [Section 5.4.7.2 “Volatile Type Qualifier”](#). The compiler will restrict the optimizations performed on volatile objects, see [Section 5.13 “Optimizations”](#).

Even when objects are marked as `volatile`, the compiler cannot guarantee that they will be accessed atomically. This is particularly true of operations on multi-byte objects, but, indeed, many operations on single-byte or bit objects cannot be performed in one instruction.

Interrupts should be disabled around any code that modifies an object that is used by interrupt functions, unless you can guarantee that the access is atomic. Check the assembler list file to see the code generated for a statement, but remember that the instructions can change as the program is developed, particularly if the optimizers are enabled.

## 5.9.7 Function Duplication

It is assumed by the compiler that an interrupt can occur at any time. Functions encoded to use the compiled stack are not reentrant (see [Section 5.5.2.2.1 “Compiled Stack Operation”](#)). So, if such a function is called by an `interrupt` function and by main-line code, this could lead to code failure.

MPLAB XC8 compiler has a feature which will duplicate the generated code associated with any function that uses the non-reentrant function model and which is called from more than one call graph. There is one call graph associated with main-line code, and one for each `interrupt` function, if defined. This allows reentrancy, but recursion is still not possible, even if the function is duplicated.

Although the compiler can compile functions using a reentrant model, this feature is not available with all devices; it can also be disabled using the `--STACK` option or the `nonreentrant` specifier. See [Section 5.5.2.2 “Auto Variable Allocation and access”](#), for information on which function model is chosen for a function.

Main-line code will call the generated code for the original function, and the interrupt will call that for the duplicated function. The duplication takes place only in the called function's generated code; there is no duplication of the C source code itself. The duplicated code and data uses different symbols and are allocated different memory, so are fully independent.

This is similar to the process you would need to undertake if this feature was not implemented in the compiler: the C function could be duplicated by hand, given different names and one called from main-line code; the other from the interrupt function. However, you would have to maintain both functions, and the code would need to be reverted if it was ported to a compiler that did support reentrancy.

The compiler-generated duplicate will have unique identifiers for the assembly symbols used within it. A duplicate identifier is identical to that used by the original code, but is prefixed with `i1`. Duplicated PIC18 functions use the prefixes `i1` and `i2` for the low- and high-priority interrupts, respectively.

The generated code of the function called from main-line code will not use any prefixes and the assembly names will be those normally used.

To illustrate, in a program the function `main` calls a function called `input`. This function is also called by an `interrupt` function.

Examination of the assembly list file will show generated assembly code for both the original and duplicate function. The assembly code corresponding to the C function `input()` will use the assembly label `_input`. The corresponding label used by the duplicate function will be `i1_input`. If the original function makes reference to a temporary variable, the generated code will use the symbol `??_input`, compared to `??i1_input` for the duplicate. Even local labels within the function's generated code will be duplicated in the same way. The call graph, in the assembly list file, will show the calls made to both of these functions as if they were independently written. These symbols will also be seen in the map file symbol table.

This feature allows the programmer to use the same source code with compilers that use either reentrant or non-reentrant models. It does not handle cases where functions are called recursively.

Code associated with library functions are duplicated in the same way. This also applies to implicitly-called library routines, such as those that perform division or floating-point operations associated with C operators.



## 5.9.7.1 DISABLING DUPLICATION

The automatic duplication of the function can be inhibited by the use of a special pragma.

This should only be done if the source code guarantees that an interrupt cannot occur while the function is being called from any main-line code. Typically this would be achieved by disabling interrupts before calling the function. It is not sufficient to disable the interrupts inside the function after it has been called; if an interrupt occurs when executing the function, the code can fail. See [Section 5.9.5 “Enabling Interrupts”](#), for more information on how interrupts can be disabled.

The pragma is:

```
#pragma interrupt_level 1
```

The pragma should be placed before the definition of the function that is not to be duplicated. The pragma will only affect the first function whose definition follows.

For example, if the function `read` is only ever called from main-line code when the interrupts are disabled, then duplication of the function can be prevented if it is also called from an interrupt function as follows.

```
#pragma interrupt_level 1
int read(char device)
{
    // ...
}
```

In main-line code, this function would typically be called as follows:

```
di(); // turn off interrupts
read(IN_CH1);
ei(); // re-enable interrupts
```

The level value specified indicates for which interrupt the function will not be duplicated. For mid-range devices, the level should always be 1; for PIC18 devices it can be 1 or 2 for the low- or high-priority interrupt functions, respectively. To disable duplication for both interrupt priorities, use the pragma twice to specify both levels 1 and 2. The following function will not be duplicated if it is also called from the low- and high-priority interrupt functions.

```
#pragma interrupt_level 1
#pragma interrupt_level 2
int timestwo(int a) {
    return a * 2;
}
```

## 5.10 MAIN, RUNTIME STARTUP AND RESET

The identifier `main` is special. You must always have one, and only one, function called `main()` in your programs. This is the first function to execute in your program.

Code associated with `main()`; however, is not the first code to execute after Reset. Additional code provided by the compiler, and known as the runtime startup code, is executed first and is responsible for transferring control to the `main()` function. The actions and control of this code is described in the following sections.

The compiler inserts special code at the end of `main()` which is executed if this function ends, i.e., a `return` statement inside `main()` is executed, or code execution reaches the `main()`'s terminating right brace. This special code causes execution to jump to address 0, the Reset vector for all 8-bit PIC devices. This essentially performs a software Reset. Note that the state of registers after a software Reset can be different to that after a hardware Reset.

It is recommended that the `main()` function does not end. Add a loop construct (such as a `while(1)`) that will never terminate either around your code in `main()` or at the end of your code, so that execution of the function will never terminate. For example,

```
void main(void)
{
    // your code goes here
    // finished that, now just wait for interrupts
    while(1)
        continue;
}
```

### 5.10.1 Runtime Startup Code

A C program requires certain objects to be initialized and the device to be in a particular state before it can begin execution of its function `main()`. It is the job of the *runtime startup* code to perform these tasks, specifically (and in no particular order):

- Initialization of global variables assigned a value when defined
- Clearing of non-initialized global variables
- General set up of registers or device state

Rather than the traditional method of linking in a generic, precompiled routine, MPLAB XC8 uses a more efficient method which actually determines what runtime startup code is required from the user's program. Details of the files used and how the process can be controlled are described in [Section 4.4.2 "Startup and Initialization"](#). The following sections detail exactly what the runtime startup code actually does.

The runtime startup code is executed before `main()`, but if you require any special initialization to be performed immediately after Reset, you should use the powerup feature described later in [Section 5.10.2 "The Powerup Routine"](#).

The runtime startup code assumes that the device has just come out of Reset and that registers will be holding their power-on-reset value. If your program is an application invoked by a bootloader that will have already executed, you might need to ensure that data bank 0 is selected so that the runtime startup code executes correctly. This can be achieved by placing the appropriate code sequence towards the end of the bootloader as in-line assembly.

The following table lists the significant assembly labels used by the startup and powerup code.

**TABLE 5-14: SIGNIFICANT ASSEMBLY LABELS**

Label	Location
<code>reset_vec</code>	at the Reset vector location (0x0)
<code>powerup</code>	the beginning of the powerup routine, if used
<code>start</code>	the beginning of the runtime startup code, in <code>startup.as</code>
<code>start_initialization</code>	the beginning of the C initialization startup code, in the C output code

## 5.10.1.1 INITIALIZATION OF OBJECTS

One task of the runtime startup code is to ensure that any initialized variables contain their initial value before the program begins execution. Initialized variables are those which are not `auto` objects and which are assigned an initial value in their definition. A case in point would be `input` in the following example.

```
int input = 88;
void main(void) { ...
```

Such initialized objects have two components: their initial value (0x0088 in the above example) stored in program memory (i.e., placed in the HEX file), and space for the variable reserved in RAM it will reside and be accessed during program execution (runtime).

The psects used for storing these components are described in [Section 5.15.2 “Compiler-Generated Psects”](#).

The runtime startup code will copy all the blocks of initial values from program memory to RAM so that the variables will contain the correct values before `main()` is executed. This action can be omitted by disabling the `init` suboption of `--RUNTIME`.

For example:

```
--RUNTIME=default,-init
```

With this part of the runtime startup code absent, the contents of initialized variables will be unpredictable when the program begins execution. Code relying on variables containing their initial value will fail.

Since `auto` objects are dynamically created, they require code to be positioned in the function in which they are defined to perform their initialization. As a result, initialized `auto` objects are not considered by the runtime startup code but are instead initialized by assembly code in each function output.

**Note:** Initialized `auto` variables can impact on code performance, particularly if the objects are large in size. Consider using `static` local objects instead.

Variables with contents that should be preserved over a Reset, or even power off, should be qualified with the `persistent` qualifier, see [Section 5.4.8.1 “Persistent Type Qualifier”](#). Such variables are linked at a different area of memory and are not altered by the runtime startup code in any way.

If objects are initialized, the runtime startup code which performs this will destroy the contents of the STATUS register. With some devices, the TO and PD bits in this register are required to determine the cause of Reset. You can choose to have a copy of this register taken so that it can later be examined. See [Section 5.10.1.4 “STATUS Register Preservation”](#), for more information.

## 5.10.1.2 CLEARING OBJECTS

Those non-`auto` objects which are not initialized must be cleared before execution of the program begins. This task is also performed by the runtime startup code.

Uninitialized variables are those which are not `auto` objects and which are not assigned a value in their definition, for example `output` in the following example.

```
int output;
void main(void) {...
```

Such uninitialized objects will only require space to be reserved in RAM where they will reside and be accessed during program execution (runtime).

The psects used for storing these components are described in [Section 5.15.2 “Compiler-Generated Psects”](#) and typically have a name based on the initialism “bss” (Block Started by Symbol).

The runtime startup code will clear all the memory location occupied by uninitialized variables so they will contain zero before `main()` is executed.

Variables whose contents should be preserved over a Reset should be qualified with `persistent`. See [Section 5.4.8.1 “Persistent Type Qualifier”](#) for more information. Such variables are linked at a different area of memory and are not altered by the runtime startup code in any way.

If objects are initialized, the runtime startup code that performs this will destroy the contents of the STATUS register. With some devices, the TO and PD bits in this register are required to determine the cause of Reset. You can choose to have a copy of this register taken so that it can later be examined. See [Section 5.10.1.4 “STATUS Register Preservation”](#) for more information.

## 5.10.1.3 SETUP OF DEVICE STATE

Some PIC devices come with an oscillator calibration constant which is pre-programmed into the device's program memory. This constant can be written to the OSCCAL register to calibrate the internal RC oscillator, if required.

Code is automatically placed in the runtime startup code to load this calibration value, see [Section 5.3.11 “Oscillator Calibration Constants”](#).

If the software stack is being used by the program, the stack pointer (FSR1) is also initialized by the runtime startup code. See [Section 5.5.2.2.2 “Software Stack Operation”](#).

## 5.10.1.4 STATUS REGISTER PRESERVATION

The `resetbits` suboption of the `--RUNTIME` option (see [4.8.54 --RUNTIME: Specify Runtime Environment](#)) preserves some of the bits in the STATUS register before they are clobbered by the remainder of the runtime startup code. The state of these bits can be examined after recovering from a Reset condition to determine the cause of the Reset. This option is not available when compiling for PIC18 devices.

The entire STATUS register is saved to an assembly variable `__resetbits`. This variable can be accessed from C code using the declaration:

```
extern unsigned char __resetbits;
```

The compiler defines the assembly symbols `__powerdown` and `__timeout` to represent the bit address of the Power-down and Time-out bits within the STATUS register and can be used if required. These can be accessed from C code using the declarations:

```
extern bit __powerdown;
extern bit __timeout;
```

In the above symbols, note that the C variables use two leading underscore characters, and the assembly equivalent symbols use three. See [Section 5.12.3.1 “Equivalent Assembly Symbols”](#) for more details of the mapping.

The compiler will detect the usage of the above symbols in your code and automatically enable the `resetbits` suboption to the `--RUNTIME` option, if they are present. You may choose to enable this feature manually, if desired.

See [Section 4.9 “MPLAB X Option Equivalents”](#) for use of this option in MPLAB X IDE.

## 5.10.2 The Powerup Routine

Some hardware configurations require special initialization, often within the first few instruction cycles after Reset. To achieve this there is a hook to the Reset vector provided via the `powerup` routine.

This routine can be supplied in a user-defined assembler module that will be executed immediately after Reset. A template `powerup` routine is provided in the file `powerup.as` which is located in the `sources` directory of your compiler distribution. Refer to comments in this file for more details.

The file should be copied to your working directory, modified and included into your project as a source file. No special linker options or other code is required. The compiler will detect if you have defined a `powerup` routine and will automatically use it, provided the code in this routine is contained in a psect called `powerup`.

For correct operation (when using the default compiler-generated runtime startup code), the code must end with a `GOTO` instruction to the label called `start`. As with all user-defined assembly code, any code inside this file must take into consideration program memory paging and/or data memory banking, as well as any applicable errata issues for the device you are using. The program's entry point is already defined by the runtime startup code, so this should not be specified in the `powerup` routine with the `END` directive (if used). See [Section 6.2.9.2 “END”](#) for more information on this assembler directive.

## 5.11 LIBRARIES

### 5.11.1 Standard Libraries

The C standard libraries contain a standardized collection of functions, such as string, math, and input/output routines. These functions are described in [Appendix A. Library Functions](#).

The libraries also contain C routines that are implicitly called by programs to perform tasks such as floating-point operations, integer division, and type conversions. These routines will not directly correspond to a function call in the source code.

#### 5.11.1.1 THE PRINTF ROUTINE

The code associated with the `printf` function is not precompiled into the library files. The `printf()` function is generated from a special C template file that is customized after analysis of the user's C code. See "PRINTF" for more information on using the `printf` library function.

The template file is found in the `lib` directory of the compiler distribution and is called `doprnt.c`. It contains a minimal implementation of the `printf()` function, but with the more advanced features included as conditional code that can be utilized via preprocessor macros that are defined when it (along with your code) is compiled.

The parser and code generator analyze the C source code, searching for calls to the `printf` function. For all calls, the placeholders that were specified in the `printf()` format strings are collated to produce a list of the desired functionality of the final function. The `doprnt.c` file is then preprocessed with the those macros specified by the preliminary analysis, thus creating a custom `printf()` function for the project being compiled. After parsing, the p-code output derived from `doprnt.c` is then combined with the remainder of the C program in the final code generation step.

For example, if a program contains one call to `printf()`, which looks like:

```
printf("input is: %d");
```

The compiler will note that only the `%d` placeholder is used and the `doprnt.c` module that is linked into the program will only handle printing of decimal integers.

Consider now that the code is changed and the following call to `printf()` is added.

```
printf("output is %6d");
```

Now the compiler will detect that additional code to handle printing decimal integers to a specific width must be enabled as well. As more features of `printf()` are detected, the size of the code generated for the `printf()` function will increase.

If the format string in a call to `printf()` is not a string literal as above, but is rather a pointer to a string, then the compiler will not be able to reliably predict the `printf()` usage, and so it forces a more complete version of `printf()` to be generated.

However, even without being able to scan `printf()` placeholders, the compiler can still make certain assumptions regarding the usage of the function. In particular, the compiler can look at the number and type of the additional arguments to `printf()` (those following the format string expression) to determine which placeholders could be valid. This enables the size and complexity of the generated `printf()` routine to be kept to a minimum even in this case.

For example, if `printf()` was called as follows:

```
printf(myFormatString, 4, 6);
```

the compiler could determine that, for example, no floating-point placeholders are required and omit these from being included in the `printf()` function output. As the arguments after the format string are non-prototyped parameters, their type must match that of the placeholders.

No aspect of this operation is user-controllable (other than by adjusting the calls to `printf()`); however, the final `printf()` code can be observed by opening the pre-processed output of `doprnt.c`, which will be called `doprnt.pre` in your working directory, will show the C code that will actually be contained in the `printf` routine. As this code has been pre-processed, indentation and comments will have been stripped out as part of the normal actions taken by the C pre-processor.

## 5.11.2 User-Defined Libraries

User-defined libraries can be created and linked in with programs as required. Library files are easier to manage and can result in faster compilation times, but must be compatible with the target device and options for a particular project. Several versions of a library might need to be created to allow it to be used for different projects.

Although libraries can be created manually using the librarian, `LIBR`, (see [Section 8.2 “Librarian”](#)) it is recommended that they be created directly from the compiler using the `--OUTPUT=lpp` option, see [Section 4.8.47 “--OUTPUT= type: Specify Output File Type”](#).

Library files should be built with the `--ASMLIST` option disabled (see [Section 4.8.16 “--ASMLIST: Generate Assembler List Files”](#)), and libraries should never contain a `main()` function or `interrupt` functions, although any function called from these may be included.

Once built, user-created libraries can be used on the command line along with the source files or added to the Libraries folder in your MPLAB X IDE project.

As with Standard C library functions, any functions contained in user-defined libraries should have a declaration added to a header file. It is common practice to create one or more header files that are packaged with the library file. These header files are then included into source code when required.

Library files specified on the command line are initially scanned for unresolved symbols; so, these files can redefine anything that is defined in the C standard libraries. See also, [Section 5.15.5 “Replacing Library Modules”](#).

## 5.11.3 Using Library Routines

Standard library functions (and any associated variables) will be automatically linked into a program once they have been referenced in your source code. The use of a function from one library file will not include any other functions from that library. Only used library functions will be linked into the program output and consume memory.

Your program will require declarations for any functions or symbols used from libraries. These are contained in the standard C header (`.h`) files. Header files are not library files and the two files types should not be confused. Library files contain precompiled code, typically functions and variable definitions; the header files provide declarations (as opposed to definitions) for functions, variables and types in the library files, as well as other preprocessor macros.

In the following example, the definition for `sqrt` is not contained in source code, so the compiler searches the libraries to find a definition there. Once found, it links in the function for `sqrt` into your program.

```
#include <math.h>    // declare function prototype for sqrt

void main(void)
{
    double i;

    // sqrt referenced; sqrt will be linked in from library file
    i = sqrt(23.5);
}
```



## 5.12 MIXING C AND ASSEMBLY CODE

Assembly language code can be mixed with C code using two different techniques: writing assembly code and placing it into a separate assembler module, or including it as in-line assembly in a C module.

**Note:** The more assembly code a project contains, the more difficult and time consuming will be its maintenance. As the project is developed, the compiler can perform different optimizations as these are based on the entire program. Assembly code might need revision if the compiler is updated due to differences in the way the updated compiler may work. These factors do not affect code written in C.  
If assembly must be added, it is preferable to write this as a self-contained routine in a separate assembly module, rather than in-lining it in C code.

### 5.12.1 Integrating Assembly Language Modules

Entire functions can be coded in assembly language as separate `.as` or `.asm` source files included into your project. They will be assembled and combined into the output image using the linker.

By default, such modules are not optimized by the assembler optimizer. Optimization can be enabled by using the `--OPT` option, see [Section 4.8.45 "--OPT: Invoke Compiler Optimizations"](#).

The following are guidelines that must be adhered to when writing a C-callable assembly routine.

- Include the `<xc.inc>` assembly header file if you need to use SFRs in your code. (If this is included using `#include`, enable the assembly source preprocessing option, see [Section 4.8.10 "-P: Preprocess Assembly Files"](#).)
- Select, or define, a suitable psect for the executable assembly code (See [Section 5.15.1 "Program Sections"](#) for an introductory guide to these.)
- Select a name (label) for the routine using a leading underscore character
- Ensure that the routine's label is globally accessible from other modules
- Select an appropriate C-equivalent prototype for the routine on which argument passing can be modeled
- Limit arguments and return values to single byte-sized objects (Assembly routines cannot define variables that reside in the compiled stack. Use global variables for additional arguments.)
- Optionally, use a signature value to enable type checking when the function is called
- Use bank selection instructions and mask addresses of any variable symbols

The following example goes through these steps for a mid-range device. The process is the same for other devices. A mapping is performed on the names of all C functions and non-`static` global variables. See [Section 5.12.3 "Interaction between Assembly and C Code"](#) for a complete description of mappings between C and assembly identifiers.

An assembly routine is required which can add an 8-bit quantity passed to the routine with the contents of `PORTB` and return this as an 8-bit quantity.

Most compiler-generated executable code is placed in psects called `textn`, where `n` is a number. (see [Section 5.15.2 "Compiler-Generated Psects"](#)). We will create our own text psect based on the psect the compiler uses. Check the assembly list file to see how



the text psects normally appear for assembly generated from C code. You can see a psect, such as the following, generated by the code generator when compiling for base-line or mid-range devices.

```
PSECT text0,local,class=CODE,delta=2
```

See [Section 6.2.9.3 “PSECT”](#) for detailed information on the flags used with the `PSECT` assembler directive. This psect is called `text0`. It is flagged `local`, which means that it is distinct from other psects with the same name. This flag is not important in this example and can be omitted, if required. It lives in the `CODE` class. This flag is important as it means it will be automatically placed in the area of memory set aside for code. With this flag in place, you do not need to adjust the default linker options to have the psect correctly placed in memory. The last option, the `delta` value, is also very important. This indicates that the memory space in which the psect will be placed is word addressable (value of 2). The PIC10/12/16 program memory space is word addressable; the data space is byte addressable.

For PIC18 devices, program memory is byte addressable, but instructions must be word-aligned, so you will see code such as the following.

```
PSECT text0,local,class=CODE,reloc=2
```

In this case, the `delta` value is 1 (which is the default setting), but the `reloc` (alignment) flag is set to 2, to ensure that the section starts on a word-aligned address.

We simply need to choose a different name, so we might choose the name `mytext`, as the psect name in which we will place our routine, so we have for our mid-range example:

```
PSECT mytext,local,class=CODE,delta=2
```

Let's assume we would like to call this routine `add` in the C domain. In assembly domain we must choose the name `_add` as this then maps to the C identifier `add`. If we had chosen `add` as the assembly routine, then it could never be called from C code. The name of the assembly routine is the label that we will place at the beginning of the assembly code. The label we would use would look like this.

```
_add:
```

We need to be able to call this from other modules, so make this label globally accessible, by using the `GLOBAL` assembler directive ([Section 6.2.9.1 “GLOBAL”](#)).

```
GLOBAL _add
```

By compiling a dummy C function with a similar prototype to this assembly routine, we can determine the signature value. The C-equivalent prototype to this routine would look like:

```
unsigned char add(unsigned char);
```

Check the assembly list file for the signature value of such a function. You will need to turn the assembler optimizer off for this step, as the optimizer removes these values from the assembly list file. Signature values are not mandatory, but allow for additional type checking to be made by the linker. We determine that the following `SIGNAT` directive ([Section 6.2.9.22 “SIGNAT”](#)) can be used.

```
SIGNAT _add,4217
```

The `W` register will be used for passing in the argument. See [Section 5.8.6 “Function Parameters”](#), for the convention used to pass parameters.

Here is an example of the complete routine for a mid-range device which could be placed into an assembly file and added to your project. The `GLOBAL` and `SIGNAT` directives do not generate code, and hence do not need to be inside the `mytext` psect, although you can place them there if you prefer. The `BANKSEL` directive and `BANKMASK` macro have been used to ensure that the correct bank was selected and that all addresses are masked to the appropriate size.

```
#include <xc.inc>

GLOBAL _add          ; make _add globally accessible
SIGNAT _add,4217     ; tell the linker how it should be called

; everything following will be placed into the mytext psect
PSECT mytext,local,class=CODE,delta=2
; our routine to add to ints and return the result
_add:
    ; W is loaded by the calling function;
    BANKSEL    (PORTB)          ; select the bank of this object
    ADDWF     BANKMASK(PORTB),w ; add parameter to port
    ; the result is already in the required location (W)so we can
    ; just return immediately
    RETURN
```

To compile this, the assembly file must be preprocessed (as we have used the C pre-processor `#include` directive). See [Section 4.8.10 “-P: Preprocess Assembly Files”](#).

To call an assembly routine from C code, a declaration for the routine must be provided. This ensures that the compiler knows how to encode the function call in terms of parameters and return values.

Here is a C code snippet that declares the operation of the assembler routine, then calls the routine.

```
// declare the assembly routine so it can be correctly called
extern unsigned char add(unsigned char a);

void main(void) {
    volatile unsigned char result;

    result = add(5); // call the assembly routine
}
```

## 5.12.2 #asm, #endasm and asm()

Assembly instructions can also be directly embedded in-line into C code using the directives `#asm`, `#endasm` or the statement `asm()` ; .

The `#asm` and `#endasm` directives are used to start and end a block of assembly instructions which are to be embedded into the assembly output of the code generator. The `#asm` block is not syntactically part of the C program, and thus it does not obey normal C flow-of-control rules. This means that you should not use this form of in-line assembly inside or near C constructs like `if()`, `while()`, and `for()` statements. However, this is the easiest means of adding multiple assembly instructions. The `#asm` and `#endasm` directives should appear on lines separate from the assembly code and each other.

The `asm()` ; statement is used to embed assembler instructions in-line with C code. This form looks and behaves like a C statement. The instructions are placed in a string inside what look like function call brackets, although no call takes place. Typically one instruction is placed in the string, but you can specify more than one assembly instruction by separating the instructions with a `\n` character, e.g., `asm("MOVLW 55\nMOVWF _x") ;`, Code will be more readable if you one place one instruction in each statement and use multiple statements.

You can use the `asm()` form of in-line assembly at any point in the C source code as it will correctly interact with all C flow-of-control structures. It is recommended, where possible, to use the `asm()` form of in-line assembly because this can result in better debugging.

The following example shows both methods used:

```
unsigned int var;

void main(void)
{
    var = 1;
    #asm          // like this...
        BCF 0,3
        BANKSEL(_var)
        RLF (_var)&07fh
        RLF (_var+1)&07fh
    #endasm

        // do it again the other way...
    asm("BCF 0,3");
    asm("BANKSEL _var");
    asm("RLF (_var)&07fh");
    asm("RLF (_var+1)&07fh");
}
```

In-line assembly code is never optimized by the assembler optimizer.

When using in-line assembler code, it is extremely important that you do not interact with compiler-generated code. The code generator cannot scan the assembler code for register usage; so, it will remain unaware if registers are clobbered or used by the assembly code. However, the compiler will reset all bank tracking once it encounters in-line assembly, so any SFRs or bits within SFRs that specify the current bank do not need to be preserved by in-line assembly.

The registers used by the compiler are explained in [Section 5.7 "Register Usage"](#). If you are in doubt as to which registers are being used in surrounding code, compile your program with the `--ASMLIST` option (see [Section 4.8.15 "--ADDRQUAL: Set Compiler Response to Memory Qualifiers"](#)) and examine the assembler code generated by the compiler. Remember that as the rest of the program changes, the registers and code strategy used by the compiler will change as well.

If a C function is called from main-line and interrupt code, it can be duplicated, see [Section 5.9.7 “Function Duplication”](#). Although a special prefix is used to ensure that labels generated by the compiler are not duplicated, this does not apply to labels defined in hand-written, in-line assembly code in C functions. Thus, you should not define assembly labels in in-line assembly if the containing function might be duplicated.

## 5.12.3 Interaction between Assembly and C Code

MPLAB XC8 C Compiler incorporates several features designed to allow C code to obey requirements of user-defined assembly code. There are also precautions that must be followed to ensure that assembly code does not interfere with the assembly generated from C code.

The command-line driver ensures that all user-defined assembly files have been processed first, before compilation of C source files begin. The driver is able to read and analyze certain information in the relocatable object files and pass this information to the code generator. This information is used to ensure the code generator takes into account requirement of the assembly code. See [Section 4.3.4 “Compilation of Assembly Source”](#) for further information on the compile sequence.

### 5.12.3.1 EQUIVALENT ASSEMBLY SYMBOLS

Most C symbols map to an corresponding assembly equivalent.

This mapping is such that an “ordinary” symbol defined in the assembly domain cannot interfere with an “ordinary” symbol in the C domain. So for example, if the symbol `main` is defined in the assembly domain, it is quite distinct to the `main` symbol used in C code and they refer to different locations.

The name of a C function maps to an assembly label that will have the same name, but with an *underscore* prepended. So the function `main()` will define an assembly label `_main`.

Baseline PIC devices can use alternate assembly domain symbols for functions. The destinations of call instructions on these devices are limited to the first half of a program memory page. The compiler, thus, encodes functions in two parts, as illustrated in the following example of a C function, `add()`, compiled for a baseline device.

```
entry__add:
    LJMP    _add
```

The label `entry__add` is the function's entry point and will always be located in a special psect linked in the first half of a program memory page. The code associated with this label is simply a long jump (see [Section 6.2.1.8 “Long Jumps and Calls”](#)) to the actual function body located elsewhere and identified by the label `_add`.

If you plan to call routines from assembly code, you must be aware of this limitation in the device and the way the compiler works around it for C functions. Hand-written assembly code should always call the `entry__funcName` label rather than the usual assembly-equivalent function label.

If a C function is qualified `static`, and there is more than one `static` function in the program with exactly the same name, the name of the first function will map to the usual assembly symbol and the subsequent functions will map to a special symbol with the form: `fileName@functionName`, where `fileName` is the name of the file that contains the function, and `functionName` is the name of the function.

For example, a program contains the definition for two `static` functions, both called `add`. One lives in the file `main.c` and the other in `lcd.c`. The first function will generate an assembly label `_add`. The second will generate the label `lcd@add`.

The name of a non-`auto` C variable also maps to an assembler label that will have the same name, but with an *underscore* prepended. So the variable `result` will define an assembly label: `_result`.

If the C variable is qualified `static`, there, again, is a chance that there could be more than one variable in the program with exactly the same C name. The same rules apply to non-local `static` variables as to `static` functions. The name of the first variable will map to a symbol prepended with an underscore; the subsequent symbols will have the form: `fileName@variableName`, where `fileName` is the name of the file that contains the variable, and `variableName` is the name of the variable.

For example a program contains the definition for two `static` variables, both called `result`. One lives in the file `main.c` and the other in `lcd.c`. The first function will generate an assembly label `_result`. The second will generate the label `lcd@result`.

If there is more than one local `static` variable (i.e., it is defined inside a function definition) then all the variables will have an assembly name of the form: `functionName@variableName`.

So, if there is a `static` variable called `output` in the function `read`, and another `static` variable with the same name defined in the function `update`, then in assembly the symbols can be accessed using the symbols `read@output` and `update@output`, respectively.

If there is more than one `static` function with the same name, and they contain definitions for `static` variables of the same name, then the assembly symbol used for these variables will be of the form: `fileName@functionName@variableName`.

Having two `static` variables or functions with the same name is legal, but not recommended as is easy to write code that accesses the wrong variable or calls the wrong function.

Functions that use the reentrant model do not define any symbols that allow you to access `auto` and parameter variables. You should not attempt to access these in assembly code. Special symbols for `auto` and parameter variables are defined, however, by functions that use the non-reentrant model. These symbols are described in the following paragraphs.

To allow easy access to parameter and `auto` variables on the compiled stack, special equates are defined which map a unique symbol to each variable. The symbol has the form: `functionName@variableName`. Thus, if the function `main` defines an `auto` variable called `foobar`, the symbol `main@foobar` can be used in assembly code to access this C variable.

Function parameters use the same symbol mapping as `auto` variables. If a function called `read` has a parameter called `channel`, then the assembly symbol for that parameter is `read@channel`.

Function return values have no C identifier associated with them. The return value for a function shares the same memory as that function's parameter variables, if they are present. The assembly symbol used for return values has the form `?_funcName`, where `funcName` is the name of the function returning the value. Thus, if a function, `getPort` returns a value, it will be located the address held by the assembly symbol `?_getPort`. If this return value is more than one byte in size, then an offset is added to the symbol to access each byte, e.g., `?_getPort+1`.

If the compiler creates temporary variables to hold intermediate results, these will behave like `auto` variables. As there is no corresponding C variable, the assembly symbol is based on the symbol that represents the `auto` block for the function plus an offset. That symbol is `??_funcName`, where `funcName` is the function in which the symbol is being used. So for example, if the function `main` uses temporary variables, they will be accessed as an offset from the symbol `??_main`.

## 5.12.3.2 ACCESSING REGISTERS FROM ASSEMBLY CODE

If writing separate assembly modules, SFR definitions will not automatically be accessible. The assembly header file `<xc.inc>` can be used to gain access to these register definitions. Do not use this file for assembly in-line with C code as it will clash with definitions in `<xc.h>`.

Include the file using the assembler's `INCLUDE` directive, (see [Section 6.2.10.5 "INCLUDE"](#)) or use the C preprocessor's `#include` directive. If you are using the latter method, make sure you compile with the `-P` driver option to preprocess assembly files, see [Section 4.8.10 "-P: Preprocess Assembly Files"](#).

The symbols for registers in this header file look similar to the identifiers used in the C domain when including `<xc.h>`, e.g., `PORTA`, `EECON1`, etc. They are different symbols in different domains, but will map to the same memory location.

Bits within registers are defined as the `registerName, bitNumber`. So, for example, `RA0` is defined as `PORTA, 0`.

Here is an example of a mid-range assembly module that uses SFRs.

```
#include <xc.inc>
GLOBAL _setports

PSECT text,class=CODE,local,delta=2
_setports:
    MOVLW    0xAA
    BANKSEL  (PORTA)
    MOVWF   BANKMASK(PORTA)
    BANKSEL  (PORTB)
    BSF     RB1
```

If you wish to access register definitions from assembly that is in-line with C code, ensure that the `<xc.h>` header is included into the C module. Information included by this header will define in-line assembly symbols as well as the usual symbols accessible from C code.

The symbols used for register names will be the same as those defined by `<xc.inc>`. So for example, the example given previously could be rewritten as in-line assembly as follows.

```
#asm
    MOVLW    0xAA
    BANKSEL  (PORTA)
    MOVWF   BANKMASK(PORTA)
    BANKSEL  (PORTB)
    BSF     RB1
#endasm
```

It is extremely important to ensure that you do not destroy the contents of registers that are holding intermediate values of calculations. Some registers are used by the compiler and writing to these registers directly can result in code failure. The code generator does not detect when SFRs have changed as a result of assembly code that writes to them. The list of registers used by the compiler and further information can be found in [Section 5.7 "Register Usage"](#).

## 5.12.3.3 WRITING REENTRANT ASSEMBLY ROUTINES WITH PARAMETERS

Hand-written assembly routines for Enhanced midrange and PIC18 devices can be written to use the software stack and be reentrantly called from C code. Such routines can take parameters, return values, and define their own local objects, if required.

The following are the steps that need to be followed to create such routines.

- Declare the C prototype for the routine in C source code, choosing appropriate parameter and return value types.
- In the assembly code, include the header `<xc.inc>`. Use the `-p` option if you use `#include` to do this, see [Section 4.8.10 “-P: Preprocess Assembly Files”](#).
- If required, define each auto-like variable using the `stack_auto name, size` macro, where `name` can be any valid assembler identifier and `size` is the variable's size in bytes.
- If required, define each parameter using the macro `stack_param name, size`, where `name` can be any valid assembly identifier and `size` is the variable's size in bytes. Parameters must be defined after autos and their order must match the order in which they appear in the C prototype.
- Initialize the stack *once* using the macro `alloc_stack` before any instructions in the routine.
- Immediately before *each* return instruction, restore the stack using the macro `restore_stack`.

Write the routine in assembly in the usual way, remembering to place the code in a psect with appropriate flags, and make the routine's label globally accessible. Ensure that the routine's label can be referenced by C code by having it begin with an underscore character. See [Section 3.4.7.2 “What Do I Need Other than Instructions in an Assembly Source File?”](#), for more assistance. You can place more than one assembly routine in the same module.

Each auto and parameter variable will be located at a unique offset to the stack pointer (FSR1). If you follow the above guidelines, you can use the symbol `name_offset`, which will be assigned the stack-pointer offset for the variable with `name`. These macros will exist for both auto and parameter variables. The examples that follow show how you might use this offset to access stack-based objects.

If the routine returns a value, this must be placed into the location expected by the code that calls the routine. For full details of C-callable routines, see [Section 5.8.7.2 “Software Stack Return Values”](#). But, to summarize, for objects 1 to 4 bytes in size, these must be loaded to temporary variables referenced as `btemp`, plus an offset. This symbol is automatically linked into your routine if you use the macros described above.

It is recommended that you do not arbitrarily adjust the stack pointer during the routine. The symbols that define the offset for each auto and parameter variable assume that the stack pointer has not been modified. However, if your assembly routine calls other reentrant routines (regardless of whether they are defined in C or assembly code), you must write the assembly code that pushes the arguments onto the stack, calls the function, and then removes any return value from the stack.

# MPLAB® XC8 C Compiler User's Guide

---

The following is an example of a reentrant assembly routine, `_inc`, written for a PIC16F1xxx device. Its arguments and return value are described by the C prototype:

```
extern reentrant int inc(int foo);
```

This routine returns an `int` value that is one higher than the `int` argument that is passed to it. It uses an auto variable, `x`, strictly for illustrative purposes.

```
#include <xc.inc>

PSECT text2,local,class=CODE,delta=2

GLOBAL _inc
_inc:
    stack_auto x,2      ;an auto called 'x'; 2 bytes wide
    stack_param foo,2  ;a parameter called 'foo'; 2 bytes wide
    alloc_stack

;x = foo + 1;
    moviw  [foo_offset+0]FSR1
    addlw  low(01h)
    movwf  btemp+0
    moviw  [foo_offset+1]FSR1
    movwf  btemp+1
    movlw  high(01h)
    addwfc btemp+1,f
    movf   btemp+0,w
    movwi  [x_offset+0]FSR1
    movf   btemp+1,w
    movwi  [x_offset+1]FSR1

;return x;
    moviw  [x_offset+0]FSR1
    movwf  btemp+0
    moviw  [x_offset+1]FSR1
    movwf  btemp+1

    restore_stack
    return
```



The following is an example of a reentrant assembly routine, `_add`, written for a PIC18 device. Its arguments and return value are described by the C prototype:

```
extern reentrant int add(int base, int index);
```

This routine returns an `int` value that is one higher than the `int` sum of the `base` and `index` arguments that are passed to it. It uses the auto variables, `tmp` and `result`, strictly for illustrative purposes.

```
#include <xc.inc>
```

```
psect text1,class=CODE,space=0,reloc=2
```

```
GLOBAL _add
```

```
_add:
```

```
    stack_auto tmp,2      ;an auto called 'tmp'; 2 bytes wide
    stack_auto result,2   ;an auto called 'result'; 2 bytes wide
    stack_param base,2    ;a parameter called 'base'; 2 bytes wide
    stack_param index,2   ;a parameter called 'index'; 2 bytes wide
    alloc_stack
```

```
;tmp = base + index;
```

```
    movlw base_offset
    movff PLUSW1,btemp+0
    movlw base_offset+1
    movff PLUSW1,btemp+1
    movlw index_offset
    movf PLUSW1,w,c
    addwf btemp+0,f,c
    movlw index_offset+1
    movf PLUSW1,w,c
    addwfc btemp+1,f,c
    movlw tmp_offset
    movff btemp+0,PLUSW1
    movlw tmp_offset+1
    movff btemp+1,PLUSW1
```

```
;result = tmp + 1;
```

```
    movlw tmp_offset
    movf PLUSW1,w,c
    addlw 1
    movwf btemp+0,c
    movlw tmp_offset+1
    movff PLUSW1,btemp+1
    movlw 0
    addwfc btemp+1,f,c
    movlw result_offset
    movff btemp+0,PLUSW1
    movlw result_offset+1
    movff btemp+1,PLUSW1
```

```
;return result;
```

```
    movlw result_offset
    movff PLUSW1,btemp+0
    movlw result_offset+1
    movff PLUSW1,btemp+1
```

```
    restore_stack
    return
```

## 5.12.3.4 ABSOLUTE PSECTS

Some of the information that is extracted from the initial compilation of assembly code (see [Section 4.3.4 “Compilation of Assembly Source”](#)) relates to absolute psects, specifically psects defined using the `abs` and `ovrld`, PSECT flags. See [Section 6.2.9.3 “PSECT”](#), for information on this directive.

MPLAB XC8 is able to determine the address bounds of absolute psects and uses this information to ensure that the code produced from C source by the code generator does not use memory that is required by the assembly code. The code generator will reserve any memory used by the assembly code prior to compiling C source.

Here is an example of how this works. Code contained in an assembly code file defines a table that must be located at address 0x110 in the data space.

The source file contains:

```
PSECT lkuptbl, class=RAM, space=1, abs, ovrld
ORG 110h
lookup:
    DS 20h
```

An absolute psect always starts at address 0. For such psects, you can specify a non-zero starting address by using the `ORG` directive. See [Section 6.2.9.4 “ORG”](#), for important information on this directive.

When the project is compiled, this file is assembled and the resulting relocatable object file is scanned for absolute psects. As this psect is flagged as being `abs` and `ovrld`, the bounds and space of the psect will be noted – in this case, a memory range from address 0x110 to 0x12F in memory space 1 is noted as being used. This information is passed to the code generator to ensure that this address range is not used by the assembly generated from the C code.

The linker handles all of the allocation into program memory, and so for hand-written assembly, only the psects located in data memory need be defined in this way.

## 5.12.3.5 UNDEFINED SYMBOLS

If a variable needs to be accessible from both assembly and C source code, it can be defined in assembly code, if required, but it is easier to do so in C source code.

A problem could occur if there is a variable defined in C source, but is only ever referenced in the assembly code. In this case, the code generator would remove the variable believing it is unused. The linker would be unable to resolve the symbol referenced by the assembly code and an error will result.

To work around this issue, MPLAB XC8 also searches assembly-derived object files for symbols which are undefined. see [Section 4.3.4 “Compilation of Assembly Source”](#). These will be symbols that are used, but not defined, in assembly code. The code generator is informed of these symbols, and if they are encountered in the C code, the variable is automatically marked as being volatile. This action has the same effect as qualifying the variable `volatile` in the source code, see [Section 5.4.7.2 “Volatile Type Qualifier”](#).

Global variables qualified as `volatile` will never be removed by the code generator, even if they appear to be unused throughout the program.

For example, if a C program defines a global variable as follows:

```
int input;
```

but this variable is only ever used in assembly code. The assembly module(s) can simply declare this symbol using the `GLOBAL` assembler directive, and then use it. The following PIC18 example illustrates the assembly code accessing this variable.

```
GLOBAL _input, _raster
PSECT text,local,class=CODE,reloc=2
_raster:
    MOVF    _input,w
```

The compiler knows of the mapping between the C symbol `input`, and the corresponding assembly symbol `_input` (see [Section 5.12.3 “Interaction between Assembly and C Code”](#)). In this instance the C variable `input` will not be removed and be treated as if it was qualified `volatile`.

## 5.13 OPTIMIZATIONS

The optimizations in the MPLAB XC8 compiler can be broadly grouped into C-level optimizations performed on the source code before conversion into assembly, and assembly-level optimizations performed on the assembly code generated by the compiler.

The C-level optimizations are performed early during the code generation phase and so have flow-on benefits: performing one optimization might mean that another can then be applied. As these optimizations are applied before the debug information has been produced, there is less impact on source-level debugging of programs.

Some of these optimizations are integral to the code generation process and so cannot be disabled via an option. Suggestions as to how specific optimizations can be defeated are given in the sections below.

In Standard mode, and particularly Free mode, some of these optimizations are disabled. (Hence if you want to disable as many optimizations as possible, run the compiler in the Free operating mode.) Some of the following optimizations are disabled or modified by the selection of alternate optimization settings use the `--OPT` option, see [Section 4.8.45 “--OPT: Invoke Compiler Optimizations”](#). Even if they are enabled, optimizations can only be applied if very specific conditions are met. As a result, you might see that some lines of code are optimized, but other similar lines are not.

The compiler operating mode determines the available optimizations, which are listed in [Table 5-15](#).

**TABLE 5-15: OPERATING MODE OPTIMIZATION SETS**

Mode	Optimization sets available
Free	<ul style="list-style-type: none"><li>• Basic code generator and assembler optimizations</li></ul>
STD	<ul style="list-style-type: none"><li>• Basic code generator and assembler optimizations</li><li>• Whole program assembly optimizations</li></ul>
PRO	<ul style="list-style-type: none"><li>• Basic code generator and assembler optimizations</li><li>• Whole program assembly optimizations</li><li>• Procedural abstraction (assembly optimization)</li><li>• OCG C-level optimizations</li></ul>

Assembly-level optimizations are described in [Section 6.3 “Assembly-Level Optimizations”](#).

The basic code generator optimizations consist of the following.

- **Whole-program analysis for object allocation** into data banks without having to use non-standard keywords or compiler directives.
- **Simplification and folding of constant expressions** to simplify expressions.
- **Expression tree optimizations** to ensure efficient assembly generation.

The following is a list of main OCG C-level optimizations, which simplify C expressions or code produced from C expressions. These are applied across the entire program, not just on a module-by-module basis.

- **Tracking of the current data bank** is performed by the compiler as it generates assembly code. This allows the compiler to reduce the number of bank-selection instructions generated.
- **Strength reductions and expression transformations** are applied to all expression trees before code is generated. This involves replacing expressions with equivalent, but less costly, operations.

- **Unused variables in a program are removed.** This applies to local as well as global variables. Variables removed will not have memory reserved for them, will not appear in any list or map file, and will not be present in debug information, and so will not be observable in the debugger. A warning is produced if an unused variable is encountered. Global objects qualified `volatile` will never be removed, see [Section 5.4.7.2 “Volatile Type Qualifier”](#). Taking the address of a variable or referencing its assembly-domain symbol in hand-written assembly code also constitutes use of the variable.
- **Redundant assignments to variables not subsequently used are removed,** unless the variable is `volatile`. The assignment statement is completely removed, as if it was never present in the original source code. No code will be produced for it, and you will not be able to set a breakpoint on that line in the debugger.
- **Unused functions in a program are removed.** A function is considered unused if it is not called, directly or indirectly, nor has had its address taken. The entire function is removed, as if it was never present in the original source code. No code will be produced for it and you will not be able to set a breakpoint on any line in the function in the debugger. Referencing a function’s assembly-domain symbol in a separate hand-written assembly module will prevent it being removed. The assembly code need only use the symbol in the `GLOBAL` directive.
- **Unused return expressions in a function are removed.** The return value is considered unused if the result of all calls to that function discard the return value. The code associated with calculation of the return value will be removed, and the function will be encoded as if its return type was `void`.
- **Propagation of constants is performed** where the numerical contents of a variable can be determined. Variables which are not volatile and whose value can be exactly determined are replaced with the numerical value. Uninitialized global variables are assumed to contain zero prior to any assignment to them.
- **Variables assigned a value before being read are not cleared or initialized** by the runtime startup code. Only non-`auto` variables are considered and if they are assigned a value before other code can read their value, they are treated as being `persistent`, see [Section 5.4.8.1 “Persistent Type Qualifier”](#). All `persistent` objects are not cleared by the runtime startup code, so this optimization will speed execution of the program startup.
- **Pointer sizes are optimized** to suit the target objects they can access. The compiler tracks all assignments to pointer variables and keeps a list of targets each pointer can access. As the memory space of each target is known, the size and dereference method used can be customized for each pointer.
- **Dereferencing pointers with only target can be replaced** with direct access of the target object. This applies to data and function pointers.
- **Unreachable code is removed.** C Statements that cannot be reached are removed before they generate assembly code. This allows subsequent optimizations to be applied at the C level.

MPLAB X IDE or other IDEs can indicate incorrect values when watching variables if optimizations hold a variable in a register. Try to use the ELF/DWARF debug file format to minimize such occurrences. Check the assembly list file to see if registers are used in the routine that is being debugged.

The assembly-level optimizations are described in [Section 6.3 “Assembly-Level Optimizations”](#).

## 5.14 PREPROCESSING

All C source files are preprocessed before compilation. The preprocessed file is not deleted after compilation. It will have a `.pre` extension and the same base name as the source file from which it is derived.

The `--PRE` option can be used to preprocess and then stop the compilation. See [Section 4.8.50 "--PRE: Produce Preprocessed Source Code"](#).

Assembler files can also be preprocessed if the `-P` driver option is issued. See [Section 4.8.10 "-P: Preprocess Assembly Files"](#).

### 5.14.1 C Language Comments

The MPLAB XC8 C compiler supports standard ANSI C comments, as well as C++/C99 comments. Both types are illustrated in the following table. Extended characters are not supported in comments and can cause splicing of source lines or other errors

Comment Syntax	Description	Example
<code>/* */</code>	Standard ANSI C code comment. Used for one or more lines.	<code>/* This is line 1 This is line 2 */</code>
<code>//</code>	C++/C99 code comment. Used for one line only.	<code>// This is line 1 // This is line 2</code>

### 5.14.2 Preprocessor Directives

MPLAB XC8 accepts several specialized preprocessor directives, in addition to the standard directives. All of these are listed in [Table 5-16](#) on the next page.

Macro expansion using arguments can use the `#` character to convert an argument to a string, and the `##` sequence to concatenate arguments. If two expressions are being concatenated, consider using two macros in case either expression requires substitution itself; so, for example

```
#define __paste1(a,b)  a##b  
#define __paste(a,b)  __paste1(a,b)
```

lets you use the `paste` macro to concatenate two expressions that themselves can require further expansion. Remember, also, that once a macro identifier has been expanded, it will not be expanded again if it appears after concatenation.

**TABLE 5-16: PREPROCESSOR DIRECTIVES**

Directive	Meaning	Example
#	preprocessor null directive, do nothing	#
#advisory	generate an advisory message	#advisory TODO: I need to finish this
#assert	generate error if condition false	#assert SIZE > 10
#asm	signifies the beginning of in-line assembly	#asm MOVLW FFh #endasm
#define	define preprocessor macro	#define SIZE 5 #define FLAG #define add(a,b) ((a)+(b))
#elif	short for #else #if	see #ifdef
#else	conditionally include source lines	see #if
#endasm	terminate in-line assembly	see #asm
#endif	terminate conditional source inclusion	see #if
#error	generate an error message	#error Size too big
#if	include source lines if constant expression true	#if SIZE < 10 c = process(10) #else skip(); #endif
#ifdef	include source lines if preprocessor symbol defined	#ifdef FLAG do_loop(); #elif SIZE == 5 skip_loop(); #endif
#ifndef	include source lines if preprocessor symbol not defined	#ifndef FLAG jump(); #endif
#include	include text file into source	#include <stdio.h> #include "project.h"
#info	alias for #advisory (see above)	#info I wrote this bit
#line	specify line number and filename for listing	#line 3 final
#nn	(where nn is a number) short for #line nn	#20
#pragma	compiler specific options	Refer to <a href="#">Section 5.14.4 "Pragma Directives"</a> .
#undef	undefines preprocessor symbol	#undef FLAG
#warning	generate a warning message	#warning Length not set

Preprocessor macro replacement expressions are textual and do not utilize types. Unless part of the controlling expression to the inclusion directives (discussed below), macros are not evaluated by the preprocessor. Once macros have been expanded and preprocessing is complete, the expansion forms a C expression which is evaluated by the *code generator* along with other C code. Tokens within the expanded C expression inherit a type, and values are then subject to integral promotion and type conversion in the usual way.

If a macro is part of the controlling expression to a conditional inclusion directive (`#if` or `#elif`), the macro must be evaluated by the *preprocessor*. The result of this evaluation is often different to the C-domain result for the same sequence. The preprocessor assigns sizes to literal values in the controlling expression that are equal to the largest integer size accepted by the compiler. For the MPLAB XC8 C compiler, this size is 32 bits.

The following code does not work as you might expect it to work. The preprocessor will evaluate `MAX` to be the result of a 32-bit multiplication, `0xF4240`. However, the definition of the `long int` variable, `max`, will be assigned the value `0x4240` (since the constant `1000` has a `signed int` type, and, therefore, the C-domain multiplication will also be performed using a 16-bit `signed int` type).

```
#define MAX 1000*1000
...
#if MAX > INT16_MAX // evaluation of MAX by preprocessor
long int max = MAX; // evaluation of MAX by C compiler
#else
int max = MAX; // evaluation of MAX by C compiler
#endif
```

Overflow in the C domain can be avoided by using a constant suffix in the macro (see [Section 5.4.6 "Constant Types and Formats"](#)). For example, an `L` after a number in a macro expansion indicates it should be interpreted by the C compiler as a `long`, but this suffix does not affect how the preprocessor interprets the value, if it needs to evaluate it.

So, for example:

```
#define MAX 1000*1000L
```

will evaluate to `0xF4240` in C expressions.



## 5.14.3 Predefined Macros

The compiler drivers define certain symbols to the preprocessor, allowing conditional compilation based on chip type, etc. The symbols listed in Table 5-17 show the more common symbols defined by the drivers.

Each symbol, if defined, is equated to 1 (unless otherwise stated).

**TABLE 5-17: PREDEFINED MACROS**

Symbol	When set	Usage
<code>__CHIPNAME</code> and <code>__CHIPNAME__</code>	when chip selected	to indicate the specific chip type selected, e.g., <code>__16F877</code>
<code>__DATABANK</code>	if eeprom or flash memory implemented	identifies which bank the EEDATA/PMDATA register is found
<code>__DATE__</code>	always	to indicate the current date, e.g., <code>May 21 2004</code>
<code>__EXTMEM</code>	if device has external memory	to indicate the size of external memory, if applicable
<code>__FILE__</code>	always	to indicate this source file being preprocessed
<code>__FLASHTYPE</code>	if non-PIC18 flash memory is implemented	to indicate the type of flash memory employed by the target device, see <code>__PROGMEM</code> below
<code>__LINE__</code>	always	to indicate this source line number
<code>__J_PART</code>	if PIC <sup>®</sup> 18 J device	indicates device is a 'J' series part
<code>__MPLAB_ICDX__</code>	if compiling for MPLAB <sup>®</sup> ICD2/3 debugger	(where <i>x</i> is 2, or 3) assigned 1 to indicate that the code is generated for use with the Microchip MPLAB ICD 2, or ICD 3
<code>__MPLAB_PICKITX__</code>	if compiling for MPLAB PICKit <sup>™</sup> 2/3	assigned 1 to indicate that the code is generated for use with the Microchip MPLAB PICKit 2 or PICKit 3
<code>__MPLAB_REALICE__</code>	if compiling for MPLAB REAL ICE <sup>™</sup> In-Circuit Emulator	assigned 1 to indicate that the code is generated for use with the Microchip MPLAB REAL ICE
<code>__OPTIMIZE_SPEED__</code>	if <code>--OPT</code> set to speed	to indicate speed optimizations in effect
<code>__OPTIMIZE_SPACE__</code> and <code>__OPTIMIZE_SIZE__</code>	if <code>--OPT</code> set to space	to indicate space optimizations in effect
<code>__OPTIMIZE_NONE__</code>	if <code>--OPT</code> set to none	to indicate no optimizations in effect
<code>__OPTIM_FLAGS</code>	always	to indicate the optimizations in effect (see text following this table)
<code>__PICCPRO__</code> and <code>__PICC__</code>	if any non-PIC18 device	to indicate the target device is any PIC10/12/14/16
<code>__PICC18__</code>	if not in C18 compatibility mode	to indicate non-C18 compatibility mode operation
<code>__RESETBITS_ADDR</code>	if <code>--RUNTIME</code> option request STATUS register save	indicates the address at which the STATUS register will be saved
<code>__STACK</code>	always	assigned with <code>__STACK_COMPILED<sup>(1)</sup></code> , <code>__STACK_HYBRID<sup>(2)</sup></code> or <code>__STACK_REENTRANT<sup>(4)</sup></code> to indicate the global stack setting: compiled, hybrid or software, respectively
<code>__STRICT</code>	if the <code>--STRICT</code> option is enabled	to indicate that strict ANSI compliance of keywords is in force
<code>__TIME__</code>	always	to indicate the current time, e.g., <code>08:06:31</code>

**Note 1:** To determine the family macro relevant to your device, look for the FAMILY field in the `picc-18.ini` file in the compiler's DAT directory.

**2:** These macros relate only to Flash program memory. They do not convey any information regarding Flash data memory.

# MPLAB® XC8 C Compiler User's Guide

**TABLE 5-17: PREDEFINED MACROS (CONTINUED)**

Symbol	When set	Usage
<code>__TRADITIONAL18__</code>	if PIC18 device	to indicate the non-extended instruction set is selected
<code>__XC</code>	always	indicates MPLAB XC compiler for Microchip is in use
<code>__XC8</code>	always	indicates MPLAB XC compiler for Microchip 8-bit devices is in use
<code>__XC8_VERSION</code>	always	to indicate the compiler's version number multiplied by 1000, e.g., v1.00 will be represented by 1000
<code>__CHIPNAME</code>	when chip selected	to indicate the specific chip type selected, e.g., <code>_16F877</code>
<code>__BANKBITS__</code>	if non-PIC18 device	assigned 0, 1 or 2 to indicate 1, 2 or 4 available banks or RAM
<code>__BANKCOUNT__</code>	if non-PIC18 device	to indicate the number of banks of data memory implemented
<code>__COMMON__</code>	if common RAM present	to indicate whether device has common RAM area
<code>__EEPROMSIZE</code>	if non-PIC18 device	to indicate how many bytes of EEPROM are available
<code>__EEPROM_INT</code>	any non-PIC18 device	value is one of 2 ( <code>__NVMREG_INT</code> ), 1 ( <code>__EEREG_INT</code> ), or 0 ( <code>__NOREG_INT</code> ) to indicate the device uses the RVMREG, EEREG, or no register interface to access EEPROM.
<code>__ERRATA_TYPES</code>	always	indicates the errata workarounds being applied, see <code>--ERRATA</code> option, <a href="#">Section 4.8.27 "--ERRATA: Specify Errata Workarounds"</a>
<code>__FAMILY_FAMILY__</code> <sup>(1)</sup>	if PIC18 device	indicates PIC18 family
<code>__FLASH_ERASE_SIZE</code> <sup>(2)</sup>	always	size of flash erase block
<code>__FLASH_WRITE_SIZE</code> <sup>(2)</sup>	always	size of flash write block
<code>__GPRBITS__</code>	if non-PIC18 device	assigned 0, 1 or 2 to indicate 1, 2 or 4 available banks or general purpose RAM.
<code>__GPRCOUNT__</code>	if non-PIC18 device	assigned a value which indicates the number of banks that contain general-purpose RAM
<code>__HAS_OSCVAL__</code>	if the target device has an oscillator calibration register	to indicate target device can require oscillator calibration
<code>__HTC_EDITION__</code>	always	indicates which compiler, PRO, Standard or Free, is in use Values of 2, 1 or 0 are assigned, respectively.
<code>__HTC_VER_MAJOR__</code> <code>__HTC_VER_MINOR__</code>	always	to indicate the whole or decimal component, respectively, of the compiler's version number
<code>__HTC_VER_PATCH__</code> <code>__HTC_VER_PLVL__</code>	always	to indicate the patch level of the compiler's version number
<code>__MPC__</code>	always	indicates compiling for Microchip PIC MCU family
<code>__OMNI_CODE__</code>	always	indicates compiling using an OCG compiler
<code>__PIC12</code>	if baseline (12-bit instruction) device	to indicate selected device is a baseline PIC device
<code>__PIC12E</code>	if enhanced baseline (12-bit instruction) device	to indicate selected device is an enhanced baseline PIC device

**Note 1:** To determine the family macro relevant to your device, look for the `FAMILY` field in the `picc-18.ini` file in the compiler's `DAT` directory.

**2:** These macros relate only to Flash program memory. They do not convey any information regarding Flash data memory.

**TABLE 5-17: PREDEFINED MACROS (CONTINUED)**

Symbol	When set	Usage
<code>_PIC14</code>	if mid-range (14-bit instruction) device	to indicate selected device is a mid-range PIC device
<code>_PIC14E</code>	if Enhanced mid-range (14-bit instruction) device	to indicate selected device is an Enhanced mid-range PIC device
<code>_PIC14EX</code>	if extended-bank Enhanced mid-range (14-bit instruction) device	to indicate selected device is an extended-bank Enhanced mid-range PIC device
<code>_PIC18</code>	if PIC18 (16-bit instruction) device	to indicate selected device is an PIC18 device
<code>_PROGMEM_</code>	if compiling for mid-range device with flash memory	to indicate the type of flash memory employed by the target device: values 0xFF (unknown) 0xF0 (none) 0 (read-only) 1 (word write with auto erase) 2 (block write with auto erase) 3 (block write with manual erase)
<code>_RAMSIZE</code>	if PIC18 device	to indicate how many bytes of data memory are available
<code>_ROMSIZE</code>	always	to indicate how much program memory is available (byte units for PIC18 devices; words for other devices)
<code>ERRATA_4000_BOUNDARY</code>	if the ERRATA_4000 applies	to indicate that the 4000 word boundary errata is applied
<code>HI_TECH_C</code>	always	to indicate that the C language variety is HI-TECH C compatible
<code>MPLAB_ICD</code>	if compiling for MPLAB ICD 2/3 debugger	assigned 2 to indicate that the code is generated for use with the Microchip MPLAB ICD 2 assigned 3 for the MPLAB ICD 3

- Note 1:** To determine the family macro relevant to your device, look for the `FAMILY` field in the `picc-18.ini` file in the compiler's `DAT` directory.
- 2:** These macros relate only to Flash program memory. They do not convey any information regarding Flash data memory.

The compiler-defined macros shown in [Table 5-18](#) can be used as bitwise AND masks to determine the value held by `__OPTIM_FLAGS`, hence the optimizations used.

**TABLE 5-18: OPTIMIZATION FLAGS**

Macro	Value	Meaning
<code>__OPTIM_NONE</code>	0x0	no optimizations applied (on equality)
<code>__OPTIM_ASM</code>	0x1	assembler optimizations on C code
<code>__OPTIM_ASMFILE</code>	0x2	assembler optimizations on assembly source code
<code>__OPTIM_SPEED</code>	0x20000	optimized for speed
<code>__OPTIM_SPACE</code>	0x40000	optimized for size
<code>__OPTIM_SIZE</code>	0x40000	optimized for size
<code>__OPTIM_DEBUG</code>	0x80000	optimized for accurate debug

## 5.14.4 Pragma Directives

There are certain compile-time directives that can be used to modify the behavior of the compiler. These are implemented through the use of the ANSI standard `#pragma` facility. The format of a pragma is:

```
#pragma keyword options
```

where *keyword* is one of a set of keywords, some of which are followed by certain *options*. A list of the keywords is given in [Table 5-19](#). Those keywords not discussed elsewhere are detailed below.

**TABLE 5-19: PRAGMA DIRECTIVES**

Directive	Meaning	Example
<code>addrqual</code>	specify action of qualifiers	<code>#pragma addrqual require</code>
<code>config</code>	specify configuration bits	<code>#pragma config WDT=ON</code>
<code>inline</code>	inline function if possible	<code>#pragma inline(getPort)</code>
<code>intrinsic</code>	specify function is inline	<code>#pragma intrinsic(_delay)</code>
<code>interrupt_level</code>	allow call from interrupt and main-line code	<code>#pragma interrupt_level 1</code>
<code>pack</code>	specify structure packing	<code>#pragma pack 1</code>
<code>printf_check</code>	enable printf-style format string checking	<code>#pragma printf_check(printf) const</code>
<code>psect</code>	rename compiler-generated psect	<code>#pragma psect nvBANK0=my_nvram</code>
<code>regsused</code>	specify registers used by function	<code>#pragma regsused myFunc wreg, fsr</code>
<code>switch</code>	specify code generation for switch statements	<code>#pragma switch direct</code>
<code>warning</code>	control messaging parameters	<code>#pragma warning disable 299, 407</code>

### 5.14.4.1 THE #PRAGMA ADDRQUAL DIRECTIVE

This directive allows you to control the compiler's response to non-standard memory qualifiers. This pragma is an in-code equivalent to the `--ADDRQUAL` option and both use the same arguments, see [Section 4.8.15 "--ADDRQUAL: Set Compiler Response to Memory Qualifiers"](#).

The pragma has an effect over the entire C program and should be issued once, if required. If the pragma is issued more than once, the last pragma determines the compiler's response.

For example:

```
#pragma addrqual require
bank2 int foobar;
```

### 5.14.4.2 THE #PRAGMA CONFIG DIRECTIVE

This directive allows the device Configuration bits to be specified for PIC18 target devices. See [Section 5.3.5 "Configuration Bit Access"](#) for full details.

## 5.14.4.3 THE #PRAGMA INLINE DIRECTIVE

The `#pragma inline` directive indicates to the compiler that calls to the specified function should be as fast as possible. This pragma has the same effect as using the `inline` function specifier.

## 5.14.4.4 THE #PRAGMA INTRINSIC DIRECTIVE

The `#pragma intrinsic` directive is used to indicate to the compiler that a function will be inlined intrinsically by the compiler. The directive is only usable with special functions that the code generator will expand internally, e.g., the `_delay` function. Such functions do not have corresponding source code and are handled specially by the compiler.

**Note:** Use of this pragma with a user-defined function does *not* mean that the function will be inlined, and an error will result. See the `inline` function specifier for that operation, in [Section 5.8.1.2 “Inline Specifier”](#).

You should not attempt to redefine an existing library function that uses the `intrinsic` pragma. If you need to develop your own version of such a routine, it must not use the same name as the intrinsic function. For example, if you need to develop your own version of `memcpy()`, give this a unique name, such as `sp_memcpy()`. Check the standard header files to determine which library functions use this pragma.

## 5.14.4.5 THE #PRAGMA INTERRUPT\_LEVEL DIRECTIVE

The `#pragma interrupt_level` directive can be used to prevent duplication of functions called from main-line and interrupt code. For more information, see [Section 5.9.7.1 “Disabling Duplication”](#).

## 5.14.4.6 THE #PRAGMA PACK DIRECTIVE

All 8-bit PIC devices can only perform byte accesses to memory and so do not require any alignment of memory objects within structures. This pragma will have no effect when used.

## 5.14.4.7 THE #PRAGMA PRINTF\_CHECK DIRECTIVE

Certain library functions accept a format string followed by a variable number of arguments in the manner of `printf()`. Although the format string is interpreted at runtime, it can be compile-time checked for consistency with the remaining arguments.

This directive enables this checking for the named function, for example the system header file `<stdio.h>` includes the directive:

```
#pragma printf_check(printf) const
```

to enable this checking for `printf()`. You can also use this for any user-defined function that accepts `printf`-style format strings.

The qualifier following the function name is to allow automatic conversion of pointers in variable argument lists. The above example would cast any pointers to strings in RAM to be pointers of the type `(const char *)`.

Note that the warning level must be set to -1 or below for this option to have any visible effect. See [Section 4.8.65 “--WARN: Set Warning Level”](#).

## 5.14.4.8 THE #PRAGMA PSECT DIRECTIVE

The `#pragma psect` was used to redirect objects and functions to a new psect (section). It has been replaced by the `__section()` specifier (see [Section 5.15.4 “Changing and Linking the Allocated Section”](#)), which not only performs the same task, but is easier to use, and allows a greater flexibility because the new psects can be linked. It is recommended you always use the `__section()` specifier to location variables and function in unique psects.

The general form of this pragma looks like:

```
#pragma psect standardPsect=newPsect
```

and instructs the code generator that anything that would normally appear in the standard psect `standardPsect`, will now appear in a new psect called `newPsect`. This psect will be identical to `standardPsect` in terms of its flags and attributes; however, it will have a unique name. Thus, you can explicitly position this new psect without affecting the placement of anything in the original psect.

If the name of the standard psect that is being redirected contains a counter (e.g., `text0`, `text1`, `text2`, etc.), the placeholder `%%u` should be used in the name of the psect at the position of the counter, e.g., `text%%u`.

## 5.14.4.9 THE #PRAGMA REGSUSED DIRECTIVE

The `#pragma regsused` directive allows the programmer to indicate register usage for functions that will not be “seen” by the code generator; for example, if they were written in assembly code. It has no effect when used with functions defined in C code, but in those cases the register usage of these functions can be accurately determined by the compiler, and the pragma is not required.

The compiler can determine those registers and objects that need to be saved by an `interrupt` function. This pragma could be used, for example, to allow the compiler to ensure that interrupt functions also save any registers used by assembly routines called by that function.

The general form of the pragma is:

```
#pragma regsused routineName registerList
```

where `routineName` is the C-equivalent name of the function or routine whose register usage is being defined, and `registerList` is a space-separated list of registers' names, as shown in [Table 5-12](#).

Those registers that are not listed are assumed to be unused by the function or routine. The code generator can use any of these registers to hold values across a function call. So, if the routine does in fact use these registers, unreliable program execution can happen.

The register names are not case sensitive and a warning will be produced if the register name is not recognized. A blank list indicates that the specified function or routine uses no registers. If this pragma is not used, the compiler will assume that the external function uses all registers.

For example, a routine called `_search` is written in PIC18 assembly code. In the C source, we can write:

```
extern void search(void);  
#pragma regsused search wreg status fsr0
```

to indicate that this routine used the W register, STATUS and FSR0. Here, FSR0 expands to both FSR0L and FSR0H. These could be listed individually, if required.

## 5.14.4.10 THE #PRAGMA SWITCH DIRECTIVE

Normally, the compiler chooses how `switch` statements will be encoded to produce the smallest possible code size. The `#pragma switch` directive can be used to force the compiler to use a different coding strategy.

The general form of the switch pragma is:

```
#pragma switch switchType
```

where *switchType* is one of the available switch types (the only switch type currently implemented for PIC18 devices is `space`) that are listed in [Table 5-20](#).

**TABLE 5-20: SWITCH TYPES**

Switch Type	Description
<code>speed</code>	use the fastest switch method
<code>space</code>	use the smallest code size method
<code>time</code>	use a fixed delay switch method
<code>auto</code>	use smallest code size method (default)
<code>direct</code> (deprecated)	use a fixed delay switch method
<code>simple</code> (deprecated)	sequential xor method

Specifying the `time` option to the `#pragma switch` directive forces the compiler to generate a table look-up style `switch` method. The time taken to execute each case is the same, so this is useful where timing is an issue, e.g., state machines.

This pragma affects all subsequent code.

The `auto` option can be used to revert to the default behavior.

Information is printed in the assembly list file for each `switch` statement, showing the chosen strategy – see [Section 6.4.4 “Switch Statement Information”](#).

## 5.14.4.11 THE #PRAGMA WARNING DIRECTIVE

This pragma allows control over some of the compiler’s messages, such as warnings and errors. For full information on the messaging system employed by the compiler, see [Section 4.6 “Compiler Messages”](#).

### 5.14.4.11.1 The Warning Disable Pragma

Some warning messages can be disabled by using the `warning disable` pragma.

This pragma will only affect warnings that are produced by the parser or the code generator; i.e., errors directly associated with C code. The position of the pragma is only significant for the parser; i.e., a parser warning number can be disabled for one section of the code to target specific instances of the warning. Specific instances of a warning produced by the code generator cannot be individually controlled and the pragma will remain in force during compilation of the entire module.

The state of those warnings which have been disabled can be preserved and recalled using the `warning push` and `warning pop` pragmas. Pushes and pops can be nested to allow a large degree of control over the message behavior.

The following example shows the warning associated with assigning the address of a `const` object to a pointer to non-`const` objects. Such code normally produces warning number 359.

```
int readp(int * ip) {
    return *ip;
}

const int i = 'd';

void main(void) {
    unsigned char c;
    #pragma warning disable 359
    readp(&i);
    #pragma warning enable 359
}
```

This same effect would be observed using the following code.

```
#pragma warning push
#pragma warning disable 359
    readp(&i);
#pragma warning pop
```

Here, the state of the messaging system is saved by the `warning push pragma`. Warning 359 is disabled, then after the source code which triggers the warning, the state of the messaging system is retrieved by using the `warning pop pragma`.

#### 5.14.4.11.2 The Warning Error/Warning Pragma

It is also possible to change the types of some messages.

This is only possible by the use of the `warning pragma` and only affects messages generated by the parser or code generator. The position of the pragma is only significant for the parser; i.e., a parser message number can have its type changed for one section of the code to target specific instances of the message. Specific instances of a message produced by the code generator cannot be individually controlled and the pragma will remain in force during compilation of the entire module.

The following example shows the warning produced in the previous example being converted to an error for the instance in the function `main()`.

```
void main(void) {
    unsigned char c;
    #pragma warning error 359
    readp(&i);
}
```

Compilation of this code would result in an error, not the usual warning. The error will force compilation to cease after the current module has concluded, or immediately if the maximum error count has been reached.



## 5.15 LINKING PROGRAMS

The compiler will automatically invoke the linker unless the compiler has been requested to stop after producing an intermediate file.

The linker will run with options that are obtained from the command-line driver. These options specify the memory of the device and how the psects should be placed in the memory. No linker scripts are used.

The linker options passed to the linker can be adjusted by the user, but this is only required in special circumstances. See [Section 4.8.6 “-L-: Adjust Linker Options Directly”](#) for more information.)

The linker creates a map file which details the memory assigned to psects and some objects within the code. The map file is the best place to look for memory information. See [Section 7.4 “Map Files”](#) for a more comprehensive explanation of the detailed information in this file.

### 5.15.1 Program Sections

There is a lot of confusion as to what psects (program sections) actually are and even more confusion as to how they are placed in memory. The following aside takes the form of an analogy and examples, and serves as an introduction to how compilers must generate code and have it allocated into memory. Such an understanding is vital for assembly programmers and understanding “Can’t find space” error messages issued by the linker. Like all analogies, it can be misleading and can only be taken so far, but it relates the main principles of code generation, the linker and sections back to something that you should understand.

By the end of this section, you should have a better understanding of:

- Why assembly code has to be packed and manipulated in sections
- Why the linker packs sections into classes rather than the device memory
- Why a “Can’t find space” error message can be issued even though there is plenty of space left in a device’s memory

#### 5.15.1.1 AN ANALOGY

Our analogy is based around a company which sells components. Customers throughout the world place orders for these components. The consignments are sent from a central warehouse in shipping containers to a regional office and then delivered to the customer.

In the warehouse, a robot assembles each order. The required components are collected and placed in a box of sufficient size. The box is labeled, then placed on a conveyor belt. The label on the box indicates the destination city and country, as well as any special packing instructions.

At the other end of the conveyor belt, a packing machine reads the labels on the boxes and sorts them by destination city. Thus, all the boxes destined for the same city are collated into one holding bay.

Once the day’s order are all processed, the collated boxes in each holding bay are first wrapped in plastic to keep them together. These bundles are then placed into a shipping container bound for that country. As there might be more than one destination city in the same country, there could be many bundles placed in the same container.

And so ends another productive day in the warehouse.

## 5.15.1.2 THE COMPILER EQUIVALENT

Let's now look at the similarities and differences between this situation and the compilation process. Both these processes are compared in [Figure 5-3](#).

**FIGURE 5-3: THE WAREHOUSE AND COMPILER SIDE BY SIDE**

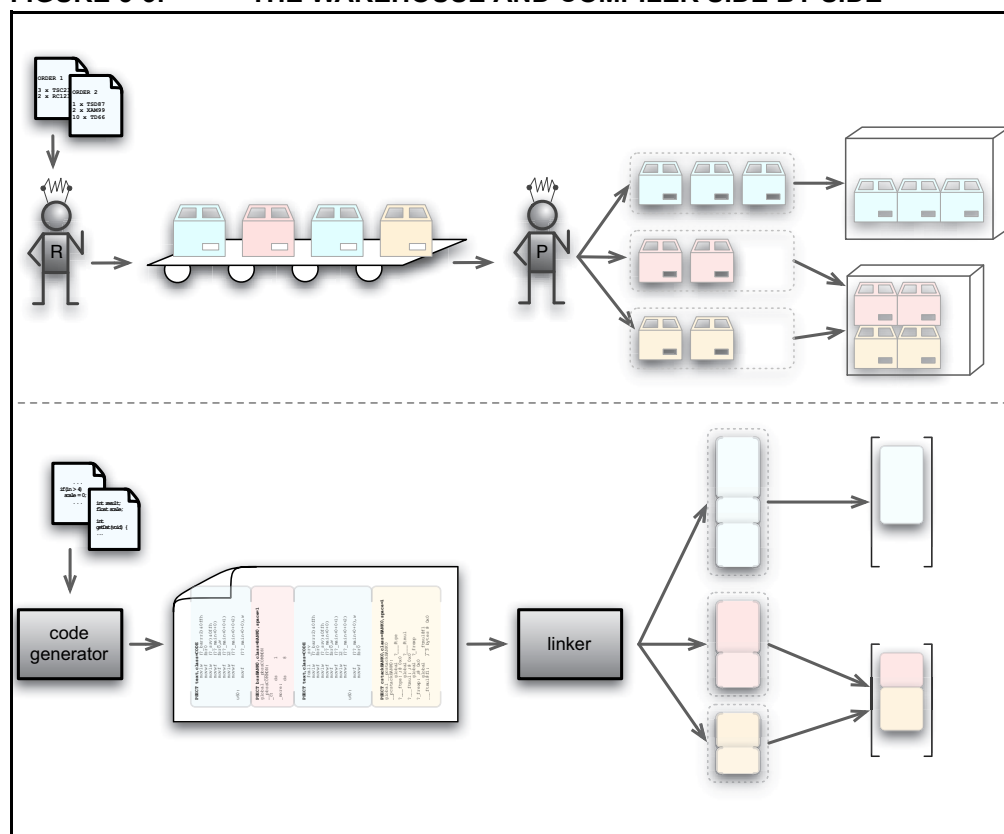

In this analogy, the warehouse is likened to the compiler. The robot is akin to the compiler's code generator application, which turns the C code into assembly code; and the packing machine, the linker, which is responsible for arranging how everything will appear in memory.

The packing machine is not actually delivering the bundles of boxes, it is just putting them into containers in the warehouse. In the same way, the linker is not actually placing sections in the device's memory; it is arranging them in conceptual containers. This analogy is not concerned with what happens outside the warehouse, nor after the compilation process – that is another story.

The following sections detail points relevant at different stages of the process.

### 5.15.1.2.1 Orders and Source Code

Both the warehouse and compiler take descriptions of something and use this to produce the final product: The warehouse receives orders, and assembles the components to fulfill that order; the compiler reads (variable and function) definitions in a C program and generates the assembly code to implement each definition.

An order from a customer can be for any number of components. In the same way, each C definition can require few or many assembly instructions or directives to be produced.

Orders arrive at the warehouse randomly, but the components are always shipped to one of several countries. Source code (variables and functions) can also be written in any order, but the compiled code is always allocated to one of several memory areas.

## 5.15.1.2.2 Boxes, Labels and Sections

In our analogy, the components for each order are placed in a box. In the same way, the assembly output generated is also placed into boxes, called program sections (or psects, for short).

There are several reasons why code is placed in a section.

- The generated assembly code is more manageable.
- The ordering of the code sequence within the section is preserved.
- The ordering of sections with the same name are preserved.
- Code is easily sorted based on where it needs to reside in memory.
- Only one command is required to locate an entire section into memory.

Any code sequence that must be contiguous is placed in the one section. The output of the compiler will typically appear in many different sections, but all sections with the same name will collate in the order in which they are produced.

The compiler has a list of section names and chooses a section based on the code it is generating, see [5.15.2 Compiler-Generated Psects](#).

A section is not a physical box, but rather a special directive is used in the assembly code to define the start of each section. The directive signifies the end of the previous box and the start of a new box. A section can hold any amount of assembly code and can even be empty.

Both the warehouse boxes and compiler sections are labeled; and, in both instances, the label indicates a destination rather than the contents. In [Figure 5-3](#) color is used to identify the destination city of a box, or the name of a section.

[Figure 5-4](#) shows what a typical box label might look like. The packing machine in the warehouse is only concerned with packing boxes in containers and so, other than the city and country, the customer's actual address is not important here.

**FIGURE 5-4: A TYPICAL BOX LABEL**

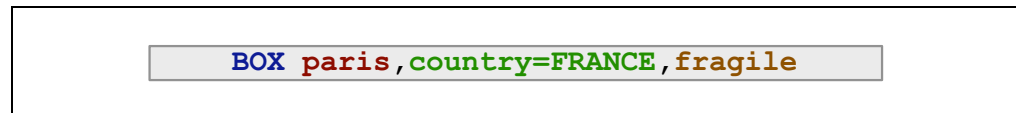

[Figure 5-5](#) shows an example of the assembly directive that is used to start a new section. The city name is now a section name and the destination country a linker class.

**FIGURE 5-5: THE SECTION DIRECTIVE AS A BOX LABEL**

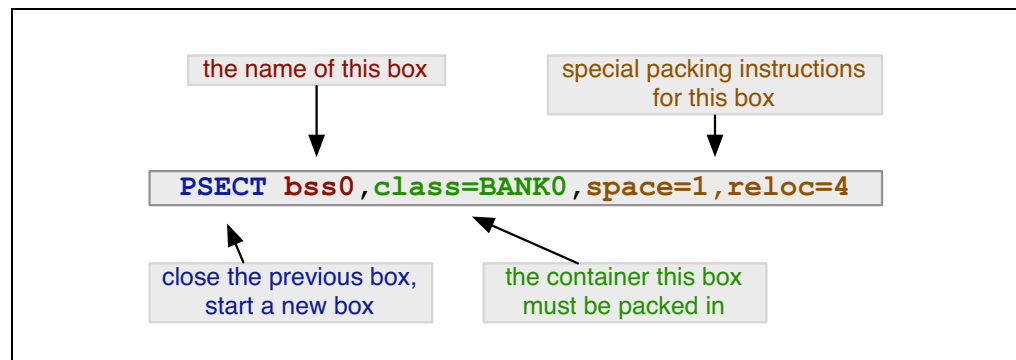

## 5.15.1.2.3 Down the Conveyor Belt and Object files

Once the robot has assembled an order and placed the components in a box, the contents of the box are no longer relevant, and the remaining activities in the warehouse only deal with boxes.

It is a similar situation in the compiler: once assembly code has been placed into a section, the instructions are no longer relevant during the link process. The linker only handles sections and is oblivious to each section's contents.<sup>1</sup>

## 5.15.1.2.4 Sorting Boxes and Sections

In the warehouse, all the boxes are sorted by destination city. After the day's orders are processed, all these similar boxes are wrapped so they can be easily kept together.

The concept is the same in the compiler domain: Sections are sorted based on the section's name, and are merged into one larger section by the linker. The order in which the sections come together strictly follows the order in which they are produced.

## 5.15.1.2.5 Loading the Containers and Classes

In the warehouse, the bundled boxes are loaded into the shipping containers. One or more shipping containers will be provided for each country. If there are orders for more than one city in the same country, then the bundled boxes for those cities can share the same container (as long as there is room).

The linker does a similar thing: It arranges the collated sections in the classes. Typically, several sections are placed in each class. The classes represent the device memory, but might take into account addressing modes or banking/paging restrictions present in the target device. Classes are often smaller than the memory space in which they are theoretically located.

Think of a large cargo ship. Although the ship can be very long, the biggest object it can hold is determined by the size of the shipping containers it transports. The shipping company cannot be able to carry an item due to size constraints even though the item is a fraction the size of the vessel.

---

1. Inside the compiler, there are actually a few steps between the code generator and linker. Assembly code is passed first to the assembler; however, the object files produced, which are passed to the linker, preserve all the sections and can be ignored in this exercise.

The assembler optimizer can alter assembly instructions, but this is only after reading and interpreting the code – something the linker cannot do. Modified code is still functionally identical to the original. Other optimizations can further merge or split sections, but this is not important to a basic understanding of the concepts.

## 5.15.1.3 SECTIONS AT WORK

Now that we have a basic understanding of the concepts, let's work through a simple example to help see how these work when compiling.

An engineer has written a program. Exactly what it does or how it is written is not important. The target device has only one bank of RAM and one page of flash.

In our very simplified example, the compiler will choose from the sections listed in [Table 5-21](#). This table also shows the linker class that is associated with each section, and the memory location in the device that the class represents.

**TABLE 5-21: SECTION NAMES FOR OUR SIMPLE EXAMPLE**

Section Name	Contents	Linker Class	Memory Location
text	Executable code	CODE	Flash
bss0	Variables that need to be cleared	BANK0	RAM
data0	Variables that need to be initialized	BANK0	RAM
idata	Initialized variable's values	CODE	Flash

The code generator starts to read the program description in C and produces the assembly code required to implement this on the target device.

The first thing the code generator encounters is the C definition for a variable with no initial value. All variables like this will be kept together so that clearing them at startup will be easier and more efficient. The code generator outputs the directive that starts a new section. Its internal table of section names indicates that `bss0` is the appropriate choice and that this section is placed in the `BANK0` class. The directive looks like this.

```
PSECT bss0,class=BANK0
```

Code follows this directive to define the variable: it merely consists of a label and another directive to reserve the required amount of memory. Altogether, this might look like the following. (Note that examples given in this section are generic and may not be relevant for your particular device)

```
PSECT bss0,class=BANK0
myVariable:
    DS 2          ; reserve 2 bytes for this object
```

The code generator continues and sees yet another uninitialized variable. As this variable will also use the same section, the code generator can keep adding to the current section and so immediately outputs another label and directive to reserve memory for the second variable.

Now a function definition is encountered in the C source. The code generator sees that output now needs to be placed in the `text` section and outputs the following directive.

```
PSECT text,class=CODE
```

This directive ends the `bss0` section and starts the `text` section. Any code following will be contained in the `text` section. Code associated with the function is generated and placed into this section.

Moving on, the code generator encounters a variable which is initialized with a value. These variables will have their initial values stored in flash and copied as a block into the RAM space allocated to them. By using one section for the RAM image and another for the initial values, the compiler can ensure that all the initial values will align after linking, as the sections will be collated in order.

The compiler first outputs the directive for the section with the name `data0`. It then outputs a label and directive to reserve memory for the variable in RAM. It next changes to the `idata` section that will hold all the initial values. Code is output that will place the initial value in this section. Notice that the code associated with initialized variables is output into two separate sections.

```
PSECT data0,class=BANK0
_StartCount:
    DS 2      ; space in RAM for the variable
PSECT idata,class=CODE
    DB 012h   ; initial values places as bytes
    DB 034h   ; which will be copied to RAM later
```

The code generator reads another initialized variable. It selects the `data0` section, outputs the label and memory reservation directive, then selects the `idata` section and stores the initial value.

This process continues until all the program has been generated. The output is passed to the linker (via the assembler), which then looks for the sections it contains.

The linker sorts each section as it is encountered. All `text` sections are collated, as well as the `bss0`, `data0` and `idata` sections. The order in which they will be assembled will match the order in which they are passed to the linker, which in turn will be the order in which they were produced by the code generator. There is now one collated `text`, `bss0`, `data0` and `idata` section.

These sections are now located in memory. The linker is passed options (from the compiler driver) which define the linker classes and the memory ranges they represent, see [Section 7.2.1 “-Aclass =low-high,...”](#)<sup>1</sup>. For our device, the linker options might look like this.

```
-ACODE=0-7ffh
-ABANK0=20h-6fh
```

So for example, the `BANK0` class covers memory from 20h to 6fh. You can see all the options passed to the linker in the map file, see [Section 7.4 “Map Files”](#).

The linker “fits” each section into the memory associated with the class it is associated with. It might, for example, place the `text` section at address 0 in the `CODE` class, then immediately follow it with the `idata` section at address 374h, for example. The `bss0` and `data0` sections will similarly be placed in the `BANK0` class.

All the sections are now allocated an address within a class. The addresses of symbols can now be determined, and ultimately a hex file is produced. The compiler's job is over.

---

1. Remember these are linker options and you cannot pass these straight to the compiler driver. You can, however, encapsulate these options in the driver's `-L-` options, see [Section 4.8.6 “-L-: Adjust Linker Options Directly”](#).

## 5.15.1.4 MORE ADVANCED TOPICS

Let's look at more complex issues with linking, now that we understand the basics.

### 5.15.1.4.1 Allocation at Specific Locations

We have seen in the preceding analogy that the linker places sections in their corresponding class when it comes time to determine where they will live in memory. This is how most sections are linked, but there are some exceptions. Code to be executed on Reset or an interrupt are examples. They cannot just be placed anywhere in a class; they must be located at specific addresses. So how are these positioned by the linker?

Any code that is to be linked at a particular address is placed in a section in the usual way. These sections will even have a class associated with them, but allocation anywhere in this class can be overridden by a special linker option which tells the linker to place the section at a specific address. In terms of our previous analogy, think of the special linker options as being explicit instructions that are given to the packing machine as to where to place the box in a container. We will see in the next example the linker options to place a section explicitly.

```
-preset_vec=0h  
-pint_text=04h
```

Note that if a section is linked in this way, the linker will follow these instructions strictly. It will warn if it is asked to place a section over the top of another, but since there is no container, which essentially represents a memory range, the linker cannot check for sections extending past the device's memory limits.

### 5.15.1.4.2 Where Classes and Containers Differ

Containers and linker classes differ in one important aspect: Linker classes are conceptual and merely represent the memory of a device; they are not physical storage.

The compiler can, and often does, use more than one class to represent the same memory range. This is illustrated in [Section 5.15.1.5 "More Advanced Sections at Work"](#), where the example uses `CODE` and `CONST` classes for flash memory. Although classes can cover the same range, typically the sizes of the containers vary. This allows code with different restrictions and requirements to be accommodated.

When the memory ranges of classes overlap, allocating to one class will result in the same memory addresses becoming unavailable in all of those classes. In fact, when any memory is allocated by the linker, by whatever means, it checks each class to see if it covers this memory and marks it as being used. This is quite a different concept from physical containers.

### 5.15.1.4.3 Multi-bin containers

Linker classes usually define one memory range, but there are instances where a class defines multiple memory ranges. You can think of this as several separate containers, but all with identical shipping destinations. Memory ranges in the class do not need to be contiguous.

The compiler typically uses a multi-range class to represent program memory that is paged. The boundaries in the memory ranges coincide with the page boundaries. This prevents sections from crossing a page boundary.

The compiler could use a similar class for banked RAM, but code can be considerably reduced in size if the destination bank of each variable is known by the code generator. You will usually see a separate class defined for each bank, and dedicated sections that are associated with these classes. The code generator will allocate a bank for each variable and choose a section destined for the class that represents that bank.

## 5.15.1.5 MORE ADVANCED SECTIONS AT WORK

Let's build on the previous example. Our target device now has two banks of RAM and two pages of flash. [Table 5-22](#) shows the extended list of sections the compiler now uses. These sections reference new classes, also shown in the table.

**TABLE 5-22: SECTION NAMES FOR OUR EXTENDED EXAMPLE**

Section Name	Contents	Linker Class	Memory Location
textn	Executable code	CODE	Flash
bss0	Variables that need to be cleared	BANK0	RAM
bss1	Variables that need to be cleared	BANK1	RAM
data0	Variables that need to be initialized	BANK0	RAM
idata	Initialized variable's values	CODE	Flash
reset_vec	Code associated with Reset	CODE	Flash
const	Read-only variables	CONST	Flash
init	Runtime startup code	CODE	Flash
int_text	Interrupt function code	CODE	Flash

The compiler operates as it did in the previous example, selecting and producing a section directive prior to generating the assembly code associated with the C source that is currently being compiled.

The assembly code associated with ordinary functions is still placed in a "text" section, but as there are now two pages of flash, we have to ensure that both pages can be used. If each function was placed into the same section, they will be merged by the linker and that section would grow until it is too large to fit into either page. To ensure that all the "text" sections do not merge, each function is placed in its own unique numbered section: `text0`, `text1`, `text2`, etc. As these sections do not have the same name, they will not be merged by the linker.

The linker option to define the `CODE` class might now look like:

```
-ACODE=0-7ffhx2
```

which tells the linker that `CODE` represents two pages of memory: one from 0 to 7ffh and another from 800h to fffh.

This specification indicates that there is some sort of memory boundary that occurs at address 800h (the device's internal memory page) and is very different from a class definition that reads `-ACODE=0-ffffh`, which covers the same memory range, but does not have the boundary. The linker will try allocating each `textx` section to one page (class memory range); if it does not fit, it will try the other.

If an interrupt function is encountered, the `int_text` section is selected for this code. As this is separate from the sections used to hold ordinary functions, it can be linked explicitly at the interrupt vector location. Assuming that the interrupt vector is at address 4, the linker option to locate this section might look like the following, see [Section 7.2.18 "-Pspec"](#).

```
-pint_text=4h
```

For simplicity in this example, initialized variables are treated as they were in the previous example, even though there are now two RAM banks; i.e., they are always allocated in the first bank of RAM.



In the previous example we ignored the code that would have copied the initial values from flash into RAM. This code is executed after Reset and before the function `main`, and forms part of the runtime startup code. It reads each initial value from flash and writes this to the corresponding variable in the RAM space. Provided the order in which the variables are allocated memory in RAM matches the order their initial values are allocated in flash, a single loop can be used to perform the copy. Even though the variables might be defined at many places in the source code, the order in memory of each variable and value will be preserved since the compiler uses sections to hold the code associated with each.

This runtime startup code is output into a section called `init`. Code which jumps to the runtime startup codes is placed in the `reset_vec` section, which is linked to the Reset location. By linking these sections in the same page, the jump from one section to another will be shorter and faster. The linker options to make this happen might look like:

```
-preset_vec=0  
-pinit=int_text
```

which says that the Reset vector code is linked to address 0 (which is the Reset vector location) and that the `init` section, which contains the runtime startup code, should be linked immediately after the interrupt code in the `int_text` section. If the `int_text` section is empty; i.e., there is no interrupt code defined in the program, then `init` will be placed at address 4.

Previously all uninitialized variables were placed in the `bss0` section. Now the code generator first checks that there will actually be enough room in bank 0 memory before doing so. If not, it chooses the `bss1` section that will ultimately be linked into bank 1 memory. The code generator keeps track of any object allocated to RAM so it can maintain the amount of free memory in each RAM bank. For these variables, the linker allocates the sections to memory, but it is the code generator that decides which section will be used by each variable. Thus, both applications play a part in the memory allocation process.

In this example, we also consider `const` variables which are stored in flash, not RAM. Each byte of data is encapsulated in a `RETLW` instruction that return the byte in the W register. Code is needed to access each byte of a variable or array. One way of doing this is a “computed goto” which involves loading the W register with an offset into the block of data and adding this to the PC. (The Microchip application note AN556 has examples of how this can be done for several devices.) A computed goto requires that the destination address (the result of adding W and PC) must not cross over a 256 word boundary (i.e., the addresses 100h, 200h, 300h, etc.). This requirement can be met using sections and a class.

In this example a new class, called `CONST`, is created and defined as follows

```
-ACONST=0-0ffhx16
```

which is to say that `CONST` is a container 100h long, but there are 16 of them one after the other in memory, so 0-ffh is one container, 100-1ffh is another, etc. We have the compiler place all the `RETLW` instructions and the computed goto code into the `const` section, which are linked into this class. The section can be located in any of the 16 containers, but must fit entirely within one.

In this example, the compiler only allows one block of `const` data. It could be made to allow many by having each block of `const` data in a unique numbered section as we did for the text sections (e.g., `const1`, `const2`, etc.). Thus each sections could remain independent and be allocated to any memory bin of the `CONST` class.

## 5.15.1.6 EXPLAINING COMMON LINKER ERRORS AND PROBLEMS

We can also use our knowledge to help explain some common linker problems and error messages.

### 5.15.1.6.1 Not Finding Space

A common linker error is, “can't find x words for psect 'abc' in class 'XYZ',” which we can now think of as, “can't find 3 cubic feet for the boxes 'paris', in container 'FRANCE'.”

The most obvious reason for this error is that the containers have been steadily filling and have finally run out of free space, i.e., the total amount of code or data you need to store exceeds the amount of memory on the device.

Another reason is that a box is larger than the container(s) in which it has to be placed. If this is the case, the section will never fit, even if the entire memory space is empty. This situation might occur when defining a very large C function, RAM or `const` array resulting in an abnormally large section. Other possible sources include large `switch` statements or even a `switch` with too many `case` labels.

The hold of a ship or aircraft might be a very large space, but freight is always packed into shipping containers and it is the size of the shipping container that dictates the maximum size of a object that can be transported. In the same way, the total amount of memory on a target device is irrelevant if sections must first be allocated to a class. Classes can seem restrictive, but without them, code will typically be less efficient or can simply fail to work altogether. The computed goto is a good example. If the table of instructions in a computed goto crosses a 100h boundary, it will fail due to the limited jump range of the instruction set.

This space error can also occur if there are many free spaces remaining in containers, but none are large enough to hold the section. This can be confusing since the total amount of free space can be larger than the section to be placed. In the same way that boxes cannot be removed from a bundle or unpacked, if a section does not fit into any remaining space, it cannot be split by the linker and an error will result. The error message indicates that largest free space that is still available.

In the same way that the label on a box can indicate special packing instructions, e.g., “fragile – pack at the top of the container”, or “this way up”, etc, a section can also indicate special memory allocation instructions. One of the most common requirements is that a section must start on an address boundary, see the `reloc PSECT` flag in [Section 6.2.9.3.15 “Reloc”](#). If a section has to fit into a class, but also has to be aligned on an address, this makes it much more difficult to locate and increases the chance that this error is produced. This is also the case if other sections or objects have been placed in the middle of a container, as we saw in [Section 5.15.1.4.1 “Allocation at Specific Locations”](#).

### 5.15.1.6.2 Not Being Shipped in the Right Container

Clearly, boxes will not be delivered correctly if they are placed in the wrong container. So too, code cannot run if it is placed in the wrong class or address. The compiler will always ensure that code and data is allocated correctly, but it is possible to manually change linker options.

The code generator assumes that sections will be located in certain memory areas and the code it generates can rely on this being the case. Typically, sections placed in RAM must remain in the bank in which they were originally destined. Sections containing executable code possibly more forgiving, but some have very specific requirements.

Remember, the linker will allow any allocation you indicate; it has no way of checking if what you tell it is correct. Always take care if you override linker options and reposition a section. [Section 5.15.2 “Compiler-Generated Psects”](#) lists the common sections used by the compiler. it also indicates restrictions on how these sections can be linked.

## 5.15.1.6.3 Doing Things by Hand

So far we have discussed assembly code produced by the code generator and how it is linked into memory; now, we consider hand-written assembly.

Imagine that in the warehouse an order is not processed by the robot, but by a human worker. The components ordered are assembled by hand, packed in a box by hand and then placed on the conveyor belt along with those boxes packed by the robot. This is quite similar to when there is hand-written assembly code in a project: the linker is passed a number of sections, some created by the code generator and some by a human.

Mistakes can be made by the warehouse worker or the assembly programmer. In the warehouse, the worker might not use a box and place the components loose on the conveyor belt, or a box might be used but it is not labeled, or it might be labeled incorrectly. In the compiler's domain, assembly code can be written without a section, or it is in a section but with the wrong (or no) class, or the section can have incorrect allocation instructions.

If assembly code is not in a section, the compiler will actually place it into a default section. But since there are no specific instructions as to what to do with this section, it could be linked anywhere. Such sections are like boxes labeled "ship to anywhere you want". As a rule of thumb, put all assembly code inside a section, but some directives (e.g., `GLOBAL` or `EQU`) do not generate code and can be placed anywhere.

The easiest way to write and locate hand-written assembly code is to associate the section you create with an existing linker class that represents a suitable memory area. This means the default linker options do not need to be altered.

The association is made using the `class` flag of the `PSECT` directive, see [Section 6.2.9.3.3 "Class"](#). If a section is to be placed at an explicit address rather than having it placed anywhere in a class, the class flag should still be used. A list of linker classes and the memory they represent is given in [Section 5.15.3 "Default Linker Classes"](#).

Even if you place your code into a section and use an appropriate class, other flags can be necessary to correctly link the code. The most important section flags are the `delta`, see [Section 6.2.9.3.4 "Delta"](#), `reloc`, see [Section 6.2.9.3.15 "Reloc"](#) and `space`, see [6.2.9.3.17 Space](#) flags. If these are incorrectly specified, the code not be positioned correctly and will almost certainly fail.

## 5.15.2 Compiler-Generated Psects

The code generator places code and data into psects (program sections) with standard names, which are subsequently positioned by the default linker options. The linker does not treat these compiler-generated psects any differently to a psect that has been defined by yourself. A psect can be created in assembly code by using the `PSECT` assembler directive (see [Section 6.2.9.3 “PSECT”](#)). The code generator uses this directive to direct assembly code it produces into the appropriate psect. For an introductory guide to psects, see [Section 5.15.1 “Program Sections”](#).

Some psects, in particular the data memory psects, use special naming conventions. For example, take the `bss` psect. The name `bss` is historical. It holds uninitialized variables. However, there can be some uninitialized variables that will need to be located in bank 0 data memory; others can need to be located in bank 1 memory. As these two groups of variables will need to be placed into different memory banks, they will need to be in separate psects so they can be independently controlled by the linker. In addition, the uninitialized variables that are `bit` variables need to be treated specially so they need their own psect. So there are a number of different psects that all use the same base name, but which have prefixes and suffixes to make them unique.

The general form of these psect names is:

```
[bit]psectBaseNameCLASS[div]
```

where *psectBaseName* is the base name of the psect, such as `bss` or `data`. The *CLASS* is a name derived from the linker class (see [Section 7.2.1 “-Aclass =low-high,...”](#)) in which the psect will be linked, e.g., `BANK0`. The prefix `bit` is used if the psect holds `bit` variables. So there can be psects like: `bssBANK0`, `bssBANK1` and `bitbssBANK0` defined by the compiler to hold the uninitialized variables.

Note that `eeprom`-qualified variables can define psects called `bssEEDATA` or `dataEEDATA`, for example, in the same way. Any psect using the class suffix `EEDATA` is placed in the HEX file and is burnt into the EEPROM space when you program the device.

If locations in a bank are reserved or are taken up by absolute objects for example, a psect cannot be formed over the entire bank. Instead, a separate psect will be used to represent the free memory on either side of the used memory. The letters `l` (elle) and `h` are used as the *div* field in the psect name to indicate if it is the lower or higher division. Thus you might see `bssBANK0l` and `bssBANK0h` psects if a split took place.

If you are unsure which psect holds an object or code in your project, check the assembly list file (see [Section 6.4.1 “General Format”](#))

The contents of these psects are described below, listed by psect base name.

## 5.15.2.1 PROGRAM SPACE PSECTS

- `checksum` – this is a psect that is used to mark the position of a checksum that has been requested using the `--CHECKSUM` option. See [Section 4.8.16 “--ASMLIST: Generate Assembler List Files”](#) for more information. The checksum value is added after the linker has executed so you will not see the contents of this psect in the assembly list file, nor specific information in the map file. Linking this psect at a non-default location will have no effect on where the checksum is stored, although the map file will indicate it located at the new address. Do not change the default linker options relating to this psect.
- `cinit` – used by the C initialization runtime startup code. Code in this psect is output by the code generator along with the generated code for the C program and does not appear in the runtime startup assembly module. This psect can be linked anywhere within a program memory page, provided it does not interfere with the requirements of other psects.
- `config` – used to store the Configuration Words. This psect must be stored in a special location in the HEX file. Do not change the default linker options relating to this psect.
- `const` – these PIC18-only psects hold objects that are declared `const` and string literals which are not modifiable. Used when the total amount of `const` data in a program exceeds 64k. This psect can be linked anywhere within a program memory page, provided it does not interfere with the requirements of other psects.
- `eeeprom (PIC18: eeeprom_data)` – used to store initial values in the EEPROM memory. Do not change the default linker options relating to this psect.
- `idata` – these psects contain the ROM image of any initialized variables. These psects are copied into the data psects at startup. In this case, the class name is used to describe the class of the corresponding RAM-based data psect. These psects will be stored in program memory, not the data memory space. These psects are implicitly linked to a location that is anywhere within the CODE linker class. The linker options can be changed allowing this psect to be placed at any address within a program memory page, provided that it does not interfere with the requirements of other psects.
- `idloc` – used to store the ID location words. This psect must be stored in a special location in the HEX file. Do not change the default linker options relating to this psect.
- `init` – used by assembly code in the runtime startup assembly module. The code in this and the `cinit` define the runtime startup code. If no interrupt code is defined code from the Reset vector can “fall through” into this psect. It is recommended that the default linker options relating to this psect are not changed in case this situation is in effect.

- `intcode`, `intcode_lo` – are the psects which contains the executable code for the high-priority (default) and low-priority interrupt service routines, respectively. These psects are linked to interrupt vector at address 0x8 and 0x18, respectively.  
Do not change the default linker options relating to these psects. See [Section 4.8.20 “--CLIST: Generate C Listing File”](#) if you want to move code when using a bootloader.
- `intentry` – contains the entry code for the interrupt service routine which is linked to the interrupt vector.  
This code saves the necessary registers and jumps to the main interrupt code in the case of mid-range devices; for enhanced mid-range devices this psect will contain the interrupt function body. (PIC18 devices use the `intcode` psects.)  
This psect must be linked at the interrupt vector. Do not change the default linker options relating to this psect. See the `--CODEOFFSET` option [Section 4.8.20 “--CLIST: Generate C Listing File”](#) if you want to move code when using a bootloader.
- `ivt0xn` – contains the vector table located at address `n` for devices which use interrupt vector tables or which are operating in legacy mode, see [Section 5.9.1 “Writing an Interrupt Service Routine”](#).
- `jmp_tab` – only used for the baseline processors, this is a psect used to store jump addresses and function return values.  
Do not change the default linker options relating to this psect.
- `maintext` – this psect will contain the assembly code for the `main()` function.  
The code for `main()` is segregated as it contains the program entry point.  
Do not change the default linker options relating to this psect as the runtime startup code can “fall through” into this psect which requires that it be linked immediately after this code.
- `mediumconst` – these PIC18-only psects hold objects that are declared `const` and string literals which are not modifiable. Used when the total amount of `const` data in a program exceeds 255 bytes, but does not exceed 64k. This psect can be linked anywhere in the lower 64k of program memory, provided it does not interfere with the requirements of other psects.
- `powerup` – contains executable code for a user-supplied powerup routine.  
Do not change the default linker options relating to this psect.
- `reset_vec` – this psect contains code associated with the Reset vector.  
Do not change the default linker options relating to this psect as it must be linked to the Reset vector location of the target device. See the `--CODEOFFSET` option [Section 4.8.20 “--CLIST: Generate C Listing File”](#), if you want to move code when using a bootloader.
- `reset_wrap` – for baseline PIC devices, this psect contains code which is executed after the device PC has wrapped around to address 0x0 from the oscillator calibration location at the top of program memory.  
Do not change the default linker options relating to this psect as it must be linked to the Reset vector location of the target device.

- `smallconst` – these psects hold objects that are declared `const` and string literals which are not modifiable.  
Used when the total amount of `const` data in a program is less than 255 bytes.  
This psect can be linked anywhere in the program memory, provided it does not cross a 0x100 boundary and it does not interfere with the requirements of other psects.
- `strings` – the `strings` psect is used for `const` objects.  
It also includes all unnamed string literals. This psect is linked into ROM, since the contents do not need to be modified.  
This psect can be linked anywhere in the program memory, provided it does not cross a 0x100 boundary or interfere with the requirements of other psects.
- `stringtext` – the `stringtext` psect is used for `const` objects when compiling for baseline devices.  
This psect is linked into ROM, since the contents do not need to be modified.  
This psect must be linked within the first half of each program memory page.
- `textn` – these psects (where *n* is a decimal number) contain all other executable code that does not require a special link location.  
These psects can be linked anywhere in the program memory, provided they do not straddle a page boundary and do not interfere with the requirements of other psects. Note that the compiler imposes pseudo page boundaries on some PIC18 devices to work around published errata. Check the default `CODE` linker class for the presence of pages, and their size, in the executable memory.
- `temp` – this psect contains compiler-defined temporary variables.<return>  
This psect must be linked in common memory, but can be placed at any address in that memory, provided it does not interfere with other psects.
- `xxx_text` – defines the psect for a function that has been made absolute; i.e., placed at an address. `xxx` will be the assembly symbol associated with the function.  
For example if the function `rv()` is made absolute, code associated with it will appear in the psect called `_rv_text`.  
As these psects are already placed at the address indicated in the C source code, the linker options that position them should not be changed.
- `xxx_const` – defines the psect for `const` object that has been made absolute; i.e., placed at an address. `xxx` will be the assembly symbol associated with the object.  
For example, if the array `nba` is made absolute, values stored in this array will appear in the psect called `_nba_const`.  
As these psects are already placed at the address indicated in the C source code, the linker options that position them should not be changed.

## 5.15.2.2 DATA SPACE PSECTS

- `nv` – these psects are used to store variables qualified `persistent`. They are not cleared or otherwise modified at startup. These psects can be linked anywhere in their targeted memory bank and should not overlap any common (unbanked memory) that the device supports if it is a banked psect.
- `bss` – these psects contain any uninitialized variables. These psects can be linked anywhere in their targeted memory bank and should not overlap any common (unbanked memory) that the device supports if it is a banked psect.
- `data` – these psects contain the RAM image of any initialized variables. These psects can be linked anywhere in their targeted memory bank and should not overlap any common (unbanked memory) that the device supports if it is a banked psect.
- `cstack` – these psects contain the compiled stack. On the stack are auto and parameter variables for the entire program. See [Section 5.5.2.2.1 “Compiled Stack Operation”](#), for information on the compiled stack. These psects can be linked anywhere in their targeted memory bank and should not overlap any common (unbanked memory) that the device supports if it is a banked psect.
- `stack` – this psect is used as a placeholder for the software stack. This stack is dynamic and its size is not known by the compiler. As described in [5.3.4.2 Data Stacks](#) this psect is typically allocated the remainder of the free data space so that the stack may grow as large as possible. This psect may be linked anywhere in the data memory, but adjusting the default linker options for this psect may limit the size of the software stack. Any overflow of the software stack may cause code failure.



## 5.15.3 Default Linker Classes

The linker uses classes to represent memory ranges. For an introductory guide to psects and linker classes, see [Section 5.15.1 “Program Sections”](#).

The classes are defined by linker options, see [Section 7.2.1 “-Aclass =low-high,...”](#) passed to the linker by the compiler driver. Psects are typically allocated space in the class they are associated with. The association is made using the `class` flag of the `PSECT` directive, see [Section 6.2.9.3.3 “Class”](#). Alternatively, a psect can be explicitly placed into a class using a linker option, see [Section 7.2.18 “-Pspec”](#).

Classes can represent a single memory range, or multiple ranges. Even if two ranges are contiguous, the address where one range ends and the other begins forms a boundary and psects placed in the class can never cross such boundaries. You will see classes that cover the same addresses, but will be divided into different ranges and have different boundaries. This is to accommodate psects whose contents were compiled under assumptions about where they would be located in memory.

Memory allocated from one class will also be reserved from other classes that specify the same memory. To the linker, there is no significance to a class name or the memory it defines.

Memory will be subtracted from these classes if using the `--ROM` or `--RAM` options, see [Section 4.8.53 “--ROM: Adjust ROM Ranges”](#) and [Section 4.8.52 “--RAM: Adjust RAM Ranges”](#), to reserve memory. When specifying a debugger, such as an ICD, see [Section 4.8.22 “--DEBUGGER: Select Debugger Type”](#), memory can also be removed from the ranges associated with some classes so that this memory is not used by your program.

Although you can manually adjust the ranges associated with a class, this is not recommended. Never change or remove address boundaries specified by a class definition option.

The following are the linker classes that can be defined by the compiler. Not all classes can be present for each device.

## 5.15.3.1 PROGRAM MEMORY CLASSES

- CODE** – consists of ranges that map to the pages on the target device. Thus, it is typically used for psects containing executable code. On baseline devices, it can only be used by code that is accessed via a jump table.
- ENTRY** – is used mainly by baseline devices for psects containing executable code that is accessed via a `CALL` instruction (calls can only be to the first half of a page). The class is defined in such a way that it is the size of a page, but psects it holds will be positioned so that they start in the first half of the page. This class is also used in mid-range devices and will consist of many ranges, each 0x100 words long and aligned on a 0x100 boundary. Thus, it is useful for psects whose contents cannot span a 0x100 word boundary.
- STRING** – consists of ranges that are 0x100 words long and aligned on a 0x100 boundary. Thus, it is useful for psects whose contents cannot span a 0x100 word boundary.
- STRCODE** – defines a single memory range that covers the entire program memory. It is useful for psects whose content can appear in any page and can cross page boundaries.
- CONST** – consists of ranges that are 0x100 words long and aligned on a 0x100 boundary. Thus, it is useful for psects whose contents cannot span a 0x100 word boundary.

## 5.15.3.2 DATA MEMORY CLASSES

- RAM** – consist of ranges that cover all the general purpose RAM memory of the target device, but excluding any common (unbanked) memory. Thus, it is useful for psects that must be placed in general-purpose banked RAM, but can be placed in any bank.
- BIGRAM** – consists of a single memory range that is designed to cover the linear data memory of enhanced mid-range devices, or the entire available memory space of PIC18 devices. It is suitable for any psect whose contents are accessed using linear addressing or which does not need to be contained in a single data bank.
- ABS1** – consist of ranges that cover all the general purpose RAM memory of the target device, including any common (unbanked) memory. Thus, it is useful for psects that must be placed in general purpose RAM, but can be placed in any bank or the common memory,
- BANK<sub>x</sub>** (where *x* is a bank number) – each consist of a single range that covers the general purpose RAM in that bank, but excluding any common (unbanked) memory.
- COMMON** – consists of a single memory range that covers the common (unbanked) RAM, if present, for all mid-range devices.
- COMRAM** – consists of a single memory range that covers the common (unbanked) RAM, if present, for all PIC18 devices.
- SFR<sub>x</sub>** (where *x* is a bank number) – each consists of a single range that covers the SFR memory in that bank. These classes would not typically be used by programmers as they do not represent general purpose RAM.

## 5.15.3.3 MISCELLANEOUS CLASSES

- CONFIG** – consists of a single range that covers the memory reserved for configuration bit data in the hex file.  
This class would not typically be used by programmers as it does not represent general purpose RAM.
- IDLOC** – consists of a single range that covers the memory reserved for ID location data in the hex file.  
This class would not typically be used by programmers as it does not represent general purpose RAM.
- EEDATA** – consists of a single range that covers the EEPROM memory of the target device, if present.  
This class would typically be used for psects that contain data that is to be programmed into the EEPROM.

## 5.15.4 Changing and Linking the Allocated Section

Section 5.15.2 “Compiler-Generated Psects” lists the default sections the compiler uses to hold objects and code. You can change the default section of a function or variable if the object has unique linking requirements that cannot be addressed by existing compiler features.

The `__section()` specifier allows you to have a variable or function redirected into a user-defined psect (section).

New psects created by the specifier for variables will have no linker class associated with them. In addition, the compiler will not make assumptions about the final location of the new psect (hence, variable). Thus, you can link variables specified with `__section()` into any data bank.

Note that the compiler will not know where the new psect will be placed until the linker is executed and any additional linker commands (see below) are processed. This means that the code used to access the relocated variable can be less efficient than the code used to access the variable without the specifier, and that other variables the compiler positions might not fit in the same bank used by the new psect. If you receive memory errors when using the `__section()` specifier, you might need to reserve memory for those variables in the new psect, see Section 4.8.52 “--RAM: Adjust RAM Ranges”.

New psects created by the specifier for functions will inherit the same psect flags. However, there are fewer linking restrictions relating to functions and this has minimal impact on the generated code.

The name of the new psect you specify must be a valid identifier in the assembler's name space. The name must contain only alphabetic or numeric characters, or the underscore character, `_`. It cannot have a name which is the same as that of an assembler directive, control, or directive flag. If the new psect will contain executable code and you wish this code to be optimized by the assembler, ensure that the psect name contains the substring “text”, e.g., `usb_text`. Psects named otherwise will not be modified by the assembler optimizer.

Variables that use the `__section()` specifier will be cleared or initialized (based on how they are defined) in the usual way by the runtime startup code (see Section 4.4.2 “Startup and Initialization”). For the case of initialized variables, the compiler will automatically allocate an additional new psect (whose name will be the same as the psect specified, prefixed with the letter `i`), which will contain the initial values. This psect must be stored in program memory, and you might need to locate this psect explicitly with a linker option.

The following are examples of a variable and function allocated to a non-default section.

```
int __section("myData") foobar;
int __section("myCode") helper(int mode) {
/* ... */ }
```

You must reserve memory, and locate via an explicit linker option, any new psect created with a `__section()` specifier. So, for example, if you wanted to place the sections created in the above example, you could use the following driver options:

```
-L-PmyData=0200h
-L-AMyCODE=50h-3ffh
-L-PmyCode=MYCODE
```

which will place the section `myData` at address `0x200`, and the section `myCode` anywhere in the range `0x50` to `0x3ff` represented by the linker class, `MYCODE`. See Section 7.2 “Operation” for linker options that can be passed using the `-L-` driver option (Section 4.8.6 “-L-: Adjust Linker Options Directly”).

If you are creating a new class for a memory range in program memory and your target is a baseline or mid-range PIC device, then you will need to inform the linker that this class defines memory that is word addressable. Do this by using the linker's `-D` option, which indicates a delta value for a class. For example:

```
-L-DMYCODE=2
```

The PIC18 devices have byte-addressable program memory and can use the default delta value associated with a class.

If you would like to set special psect flags with the new section that is created with the `__section()`, you can do this by providing a definition of the new section in your source code. For example, if you wanted the `mycode` section to be placed at an address that is a multiple of 100h, then you can place the following in your source file:

```
asm("PSECT mycode, reloc=100h");
int __section("myCode") helper(int mode) {
/* ... */ }
```

The `reloc`, `size` and `limit` psect flags can all be redefined in this way. Redefinitions might trigger assembler warning messages; however, these can be ignored in this circumstance.

## 5.15.5 Replacing Library Modules

The MPLAB XC8 C compiler comes with a librarian, `LIBR`, which allows you to unpack a library file and replace modules with your own modified versions. See [Section 8.2 “Librarian”](#). However, you can easily replace a library module that is linked into your program without having to do this.

If you add a source file to your project and it contains the definition for a routine with the same name as a library routine, then the library routine will be replaced by your routine. This is due to the way the compiler scans source and library files.

When trying to resolve a symbol (a function name, or variable name, for example) the compiler first scans all the source modules for the definition. Only if it cannot resolve the symbol in these files does it then search the library files.

If the symbol is defined in a source file, the compiler will never actually search the libraries for this symbol. No error will result if the symbol was present in both your source code and the library files. This cannot be true if a symbol is defined twice in source files and an error can result if there is a conflict in the definitions.

All library source code is written in C, and the p-code library files that contain these library routines are actually passed to the code generator, not the linker, but both these applications work in the way described above in resolving library symbols.

You cannot replace a C library function with an equivalent written in assembly code using the above method. If this is required, you will need to use the librarian to edit or create a new library file.

## 5.15.6 Signature Checking

The compiler automatically produces signatures for all functions. A signature is a 16-bit value computed from a combination of the function's return data type, the number of its parameters and other information affecting the calling sequence for the function. This signature is generated and placed in the object code whenever a function is referenced or defined.

At link time, the linker will report any mismatch of signatures, which will indicate a discrepancy between how the function is defined. MPLAB XC8 is only likely to issue a mismatch error from the linker when the routine is either a precompiled object file or an assembly routine. Other function mismatches are reported by the code generator.

It is sometimes necessary to write assembly language routines which are called from C using an `extern` declaration. Such assembly language functions should include a signature which is compatible with the C prototype used to call them. The simplest method of determining the correct signature for a function is to write a dummy C function with the same prototype and check the assembly list file using the `--ASMLIST` option (see [Section 4.8.15 "--ADDRQUAL: Set Compiler Response to Memory Qualifiers"](#)).

For example, suppose you have an assembly language routine called `_widget` which takes a `char` argument and returns a `char`. The prototype used to call this function from C would be:

```
extern char widget(char);
```

When a call to `_widget` is made in the C code, the signature for a function with one `char` argument and a `char` return value would be generated. In order to match the correct signature, the source code for `widget` needs to contain an assembler `SIGNAT` directive which defines the same signature value. To determine the correct value, you would write the following code into a dummy file:

```
char widget(char arg1)
{
}
```

The resultant assembler code seen in the assembly list file includes the following line:

```
SIGNAT _widget,4217
```

The `SIGNAT` directive tells the assembler to include a record in the `.obj` file which associates the signature value 4217 with symbol `_widget`. The value 4217 is the correct signature for a function with one `char` argument and a `char` return value.

If this directive is copied into the assembly source file which contains the `_widget` code, it will associate the correct signature with the function and the linker will be able to check for correct argument passing.

If a C source file contains the declaration:

```
extern char widget(long);
```

then a different signature will be generated and the linker will report a signature mis-match which will alert you to the possible existence of incompatible calling conventions.

## 5.15.7 Linker-Defined Symbols

The linker defines some special symbols that can be used to determine where some psects where linked in memory. These symbols can be used in code, if required.

The link address of a psect can be obtained from the value of a global symbol with name `__Lname` (two leading underscores) where `name` is the name of the psect. For example, `__LbssBANK0` is the low bound of the `bssBANK0` psect.

The highest address of a psect (i.e., the link address plus the size) is represented by the symbol `__Hname`.

If the psect has different load and link addresses, the load start address is represented by the symbol `__Bname`.

Not all psects are assigned these symbols, in particular those that are not placed in memory by a `-P` linker option. See [Section 7.2.18 “-Pspec”](#). Psect names can change from one device to another.

Assembly code can use these symbol by globally declaring them, for example:

```
GLOBAL __Lidata
```

and C code could use them by declaring a symbol such as the following.

```
extern char * _Lidata;
```

Note that there is only one leading underscore in the C domain, see [Section 5.12.3.1 “Equivalent Assembly Symbols”](#). As the symbol represents an address, a pointer is the typical type choice.

# MPLAB® XC8 C Compiler User's Guide

---

NOTES:



---

---

## Chapter 6. Macro Assembler

---

---

### 6.1 INTRODUCTION

Two macro assemblers are included with the MPLAB XC8 C Compiler to assemble source files for all 8-bit PIC devices. The operation and assembler directives are almost identical for both assemblers. The appropriate assembler application is invoked when you use the compiler driver to build projects.

The assembler is called ASPIC18 for PIC18 devices and ASPIC for all other 8-bit devices. It is available to run on Windows<sup>®</sup>, Linux<sup>®</sup> and Mac OS<sup>®</sup> X systems. Note that the assembler will not produce any messages unless there are errors or warnings – there are no “assembly completed” messages.

The command-line driver, `xc8`, should be used to invoke the assembler.

This chapter describes the directives (assembler pseudo-ops and controls) accepted by the assembler in the assembly source files or assembly inline with C code.

Although the term “assembler” is almost universally used to describe the tool that converts human-readable mnemonics into machine code, both “assembler” and “assembly” are used to describe the source code which such a tool reads. The latter is more common and is used in this manual to describe the language. Thus you will see the terms assembly language (or just assembly), assembly listing and other assembly terms, but also, assembler options, assembler directive and assembler optimizer.

The following topics are examined in this chapter of the user's guide:

- [MPLAB XC8 Assembly Language](#)
- [Assembly-Level Optimizations](#)
- [Assembly List Files](#)

## 6.2 MPLAB XC8 ASSEMBLY LANGUAGE

Information about the source language accepted by the macro assemblers is described in this section.

All opcode mnemonics and operand syntax are specific to the target device, and you should consult your device data sheet. Additional mnemonics, deviations from the instruction set, and assembler directives and controls are documented in this section.

The same assembler application is used for compiler-generated intermediate assembly and hand-written assembly source code, and for hand-written assembly modules and assembly inline with C code.

### 6.2.1 Assembly Instruction Deviations

The MPLAB XC8 assembler uses a slightly modified form of assembly language to that specified by the Microchip data sheets. The following information details changes to the instruction format, and pseudo instructions that can be used in addition to the device instruction set.

These deviations can be used in assembly code in-line with C code or in hand-written assembly modules.

#### 6.2.1.1 DESTINATION LOCATION

The PIC device data sheets indicate that some instructions use the operands “, 0” or “, 1” to specify the destination for the result of that operation. The XC8 assemblers instead use the more-readable operands “, w” and “, f” to specify the destination.

The W register is selected as the destination when using the “, w” operand, and the file register is selected when using the “, f” operand. The case of the letter in the destination operand is not important. For example (ignoring bank selection and address masking for this example):

```
MOVWF  _foo,w      ;move _foo into wreg
ADDWF  _foo,f      ;add wreg to _foo, updating the content of _foo
ADDWF  _foo,w      ;add wreg to _foo, leaving the result in wreg
```

It is highly recommended that the destination is always specified with each instruction that requires this operand. If the destination is omitted, it is assumed to be the file register. Never use the numeric destination operands.

In the same way, the PIC18 assembler also uses the RAM access operand “, b” (instead of “, 1”) to indicate that PIC18 instructions should use the bank select register (BSR) when accessing the specified file register address. The “, c” operand (instead of “, 0”) indicates that the address is in the common memory, which is known as the access bank on PIC18 devices. Alternatively, an instruction operand can be preceded by the characters “c:” to indicate that the address resides in common memory. These operands and prefix affect the RAM access bit in the instruction. For example:

```
ADDWF  _bar,f,c    ;add wreg to _bar in common memory
BTFSC  c:_bar,3    ;test bit three in the common memory symbol _bar
```

These operands and prefix are not applicable with operands to the PIC18 MOVFF instruction, which takes two untruncated addresses, and which always works independently of the BSR.

For example, the following instructions show the W register being moved to first, an absolute location; and, then, to an address represented by an identifier. Bank selection and masking has been used in this example. The PIC18 op codes for these instructions, assuming that the address assigned to `_foo` is 0x516 and to `_bar` is 0x55, are shown below.

```
6EE5 MOVWF 0FE5h           ;write to access bank location 0xFE5
6E55 MOVWF _bar,c         ;write to access bank location 0x55
0105 BANKSEL(_foo)       ;set up BSR to access _foo
6F16 MOVWF BANKMASK(_foo),b ;write to _foo (banked)
6F16 MOVWF BANKMASK(_foo) ;defaults to banked access
```

Notice that the first two instruction opcodes have the RAM access bit (bit 8 of the op-code) cleared, but that the bit is set in the last two instructions.

It is recommended that you always specify the RAM access operand or the common memory prefix. If these are not present, the instruction address is absolute, and the address is within the upper half of the access bank (which dictates that the address must not be masked), the instruction will use the access bank RAM. In all other situations, the instruction will access banked memory.

The destination operand and the RAM access operand can be listed in any order for PIC18 instructions. For example, the following two instructions are identical:

```
ADDWF _foo,f,c
ADDWF _foo,c,f
```

## 6.2.1.2 BANK AND PAGE SELECTION

The `BANKSEL` pseudo instruction can be used to generate instructions to select the bank of the operand specified. The operand should be the symbol or address of an object that resides in the data memory.

Depending on the target device, the generated code will either contain one or more bit instructions to set/clear bits in the appropriate register, or use a `MOVLB` instruction (in the case of enhanced mid-range or PIC18 devices). As this pseudo instruction can expand to more than one instruction on mid-range or baseline parts, it should not immediately follow a `BTFSX` instruction on those devices.

For example:

```
MOVLW 20
BANKSEL(_foobar) ;select bank for next file instruction
MOVWF BANKMASK(_foobar) ;write data and mask address
```

In the same way, the `PAGESEL` pseudo instruction can be used to generate code to select the page of the address operand. For the current page, you can use the location counter, `$`, as the operand.

Depending on the target device, the generated code will either contain one or more instructions to set/clear bits in the appropriate register, or use a `MOVLP` instruction in the case of enhanced mid-range PIC devices. As the directive could expand to more than one instruction, it should not immediately follow a `BTFSX` instruction.

For example:

```
FCALL _getInput
PAGESEL $ ;select this page
```

This directive is accepted when compiling for PIC18 targets but has no effect and does not generate any code. Support is purely to allow easy migration across the 8-bit devices.

## 6.2.1.3 ADDRESS MASKING

A macro, `BANKMASK()`, can be used with an identifier; so, it is usable as an operand to instructions that expect a file register address. The macro does this by ANDing out the bank information using a suitable mask. It is available once you include the `<xc.inc>` file. An example of this macro is given in [Section 6.2.1.2 “Bank and Page Selection”](#).

All MPLAB XC8 assembly identifiers represent a full address. This address includes the bank information for the object it represents. Virtually all instructions in the 8-bit PIC instruction sets that take a file register operand expect this operand value to be an offset into the currently selected bank. As the device families have different bank sizes, the width of this offset is different for each family. Use of this macro increases assembly code portability across Microchip devices, since it adjusts the mask to suit the bank size of the target device.

Do not use this macro with either operand to the PIC18's `MOVFF` instruction, which requires two full, banked addresses to be specified, or with any other instruction that expects a full address.

## 6.2.1.4 MOVFW PSEUDO INSTRUCTION

The `MOVFW` pseudo instruction implemented by MPLAB C18 is *not* implemented in MPLAB XC8. You will need to use the standard PIC instruction that performs an identical function. Note that the MPLAB C18 instruction:

```
MOVFW foobar
```

maps directly to the standard PIC instruction:

```
MOVF foobar,w
```

## 6.2.1.5 MOVIW/MOVWI INSTRUCTIONS

Both the `MOVIW` and `MOVWI` instructions have operands which differ in syntax to that indicated in the data sheet. These instructions are only available with enhanced mid-range devices.

The indexed Indirect operands to these instructions have the FSR offset specified first in square brackets, followed by the FSR name, for example:

```
MOVIW [6]FSR0  
MOVWI [0x10]FSR1
```

The pre/post increment/decrement form of these instructions use the name of the FSR register, not the indirection register (`INDF`), for example:

```
MOVIW ++FSR0  
MOVWI FSR1++  
MOVWI FSR0--
```

## 6.2.1.6 MOVFF/MOVFFL INSTRUCTIONS

The `MOVFF` instruction is a physical device instruction, but for PIC18 devices that have extended data memory, it also serves as a placeholder for the `MOVFFL` instruction.

For these devices, when generating output for the `MOVFF` instruction, the assembler checks the psects that hold the operand symbols. If the psect containing the source operand is the same psect that contains the destination operand, then the instruction is encoded as a `MOVFF` instruction. If the psects of both source and destination operands have the `lowdata` psect flag set, the instruction is also encoded as a `MOVFF` instruction. In all other situations, the instruction is encoded as a `MOVFFL` instruction.

Note that assembly list files will always show the `MOVFF` placeholder regardless of how it is encoded.

## 6.2.1.7 INTERRUPT RETURN MODE

The `RETFIE` PIC18 instruction can be followed by “f” (no comma) to indicate that the shadow registers should be retrieved and copied to their corresponding registers on execution. Without this modifier, the registers are not updated from the shadow registers. This replaces the “0” and “1” operands indicated in the device data sheet.

The following examples show both forms and the opcodes they generate.

```
0011  RETFIE f      ;shadow registers copied
0010  RETFIE       ;return without copy
```

The baseline and mid-range devices do not allow such a syntax.

## 6.2.1.8 LONG JUMPS AND CALLS

The assembler recognizes several mnemonics that expand into regular PIC MCU assembly instructions. The mnemonics are `FCALL` and `LJMP`. On baseline and mid-range parts, these instructions expand into regular `CALL` and `GOTO` instructions respectively, but also ensure the instructions necessary to set the bits in `PCLATH` (for mid-range devices) or `STATUS` (for baseline devices) will be generated when the destination is in another page of program memory. Whether the page selection instructions are generated, and exactly where they will be located, is dependent on the surrounding source code. Page selection instructions can appear immediately before the call or jump, or be generated as part of, and immediately after, a previous `FCALL/LJMP` instruction.

On PIC18 devices, these mnemonics are present purely for compatibility with smaller 8-bit devices and are always expanded as regular PIC18 `CALL` and `GOTO` instructions.

These additional mnemonics should be used where possible as they make assembly code independent of the final position of the routines that are to be executed. If the call or jump is determined to be within the current page, the additional code to set the `PCLATH` bits can be optimized away. Note that assembly code that is added in-line with C code is never optimized and assembly modules require a specific option to enable optimization, see [Section 4.8.45 “--OPT: Invoke Compiler Optimizations”](#). Unoptimized `FCALL` and `LJMP` instruction will always generate page selection code.

The following mid-range PIC example shows an `FCALL` instruction in the assembly list file. You can see that the `FCALL` instruction has expanded to five instructions. In this example, there are two bit instructions that set/clear bits in the `PCLATH` register. Bits are also set/cleared in this register after the call to reselect the page that was selected before the `FCALL`.

```
13 0079 3021                               movlw 33
14 007A 120A 158A 2000                       fcall _phantom
    120A 118A
15 007F 3400                               retlw 0
```

Since `FCALL` and `LJMP` instructions can expand into more than one instruction, they should never be preceded by an instruction that can skip, e.g., a `BTFSC` instruction.

The `FCALL` and `LJMP` instructions assume that the psect that contains them is smaller than a page. Do not use these instructions to transfer control to a label in the current psect if it is larger than a page. The default linker options will not permit code psects to be larger than a page.

On PIC18 devices, the regular `CALL` instruction can be followed by a “, f” to indicate that the `W`, `STATUS` and `BSR` registers should be pushed to their respective shadow registers. This replaces the “, 1” syntax indicated on the device data sheet.

## 6.2.1.9 RELATIVE BRANCHES

The PIC18 devices implement conditional relative branch instructions, e.g., BZ, BNZ. These instructions have a limited jump range compared to the GOTO instruction.

Note that in some instance, the assembler can change a relative branch instruction to be a relative branch with the opposite condition over a GOTO instruction. For example:

```
BZ error
;next
```

can become:

```
BNZ 118
GOTO error
118:
;next
```

This is functionally identical and is performed so that the conditional branch can use the same destination range as the GOTO instruction.

## 6.2.2 Statement Formats

Legal statement formats are shown in [Table 6-1: "ASPIC Statement Formats"](#).

The *label* field is optional and, if present, should contain one identifier. A label can appear on a line of its own, or precede a mnemonic as shown in the second format.

The third format is only legal with certain assembler directives, such as MACRO, SET and EQU. The *name* field is mandatory and should contain one identifier.

If the assembly file is first processed by the C preprocessor, see [Section 4.8.10 "-P: Preprocess Assembly Files"](#), then it can also contain lines that form valid preprocessor directives. See [Section 5.14.1 "C Language Comments"](#), for more information on the format for these directives.

There is no limitation on what column or part of the line in which any part of the statement should appear.

**TABLE 6-1: ASPIC STATEMENT FORMATS**

Format #	Field1	Field2	Field3	Field4
Format 1	<i>label:</i>			
Format 2	<i>label:</i>	<i>mnemonic</i>	<i>operands</i>	<i>; comment</i>
Format 3	<i>name</i>	<i>pseudo-op</i>	<i>operands</i>	<i>; comment</i>
Format 4	<i>; comment only</i>			
Format 5	<i>empty line</i>			

## 6.2.3 Characters

The character set used is standard 7 bit ASCII. Alphabetic case is significant for identifiers, but not mnemonics and reserved words. Tabs are treated as equivalent to spaces.

### 6.2.3.1 DELIMITERS

All numbers and identifiers must be delimited by white space, non-alphanumeric characters or the end of a line.

### 6.2.3.2 SPECIAL CHARACTERS

There are a few characters that are special in certain contexts. Within a macro body, the character `&` is used for token concatenation. To use the bitwise `&` operator within a macro body, escape it by using `&&` instead. In a macro argument list, the angle brackets `<` and `>` are used to quote macro arguments.

## 6.2.4 Comments

An assembly comment is initiated with a semicolon that is not part of a string or character constant.

If the assembly file is first processed by the C preprocessor, see [Section 4.8.10 “-P: Preprocess Assembly Files”](#), then the file can also contain C or C++ style comments using the standard `/* ... */` and `//` syntax.

### 6.2.4.1 SPECIAL COMMENT STRINGS

Several comment strings are appended to compiler-generated assembly instructions by the code generator. These comments are typically used by the assembler optimizer.

The comment string `;volatile` is used to indicate that the memory location being accessed in the instruction is associated with a variable that was declared as `volatile` in the C source code. Accesses to this location which appear to be redundant will not be removed by the assembler optimizer if this string is present.

This comment string can also be used in hand-written assembly source to achieve the same effect for locations defined and accessed in assembly code.

The comment string `;wreg free` is placed on some `CALL` instructions. The string indicates that the W register was not loaded with a function parameter; i.e., it is not in use. If this string is present, optimizations can be made to assembler instructions before the function call, which loads the W register redundantly.

## 6.2.5 Constants

### 6.2.5.1 NUMERIC CONSTANTS

The assembler performs all arithmetic with signed 32-bit precision.

The default radix for all numbers is 10. Other radices can be specified by a trailing base specifier, as given in [Table 6-2](#).

**TABLE 6-2: ASPIC NUMBERS AND BASES**

Radix	Format
Binary	Digits 0 and 1 followed by B
Octal	Digits 0 to 7 followed by O, Q, o or q
Decimal	Digits 0 to 9 followed by D, d or nothing
Hexadecimal	Digits 0 to 9, A to F preceded by 0x or followed by H or h

Hexadecimal numbers must have a leading digit (e.g., 0ffffh) to differentiate them from identifiers. Hexadecimal digits are accepted in either upper or lower case.

Note that a binary constant must have an upper case B following it, as a lower case b is used for temporary (numeric) label backward references.

In expressions, real numbers are accepted in the usual format, and are interpreted as IEEE 32-bit format.

### 6.2.5.2 CHARACTER CONSTANTS AND STRINGS

A character constant is a single character enclosed in single quotes ' .

Multi-character constants, or strings, are a sequence of characters, not including carriage return or newline characters, enclosed within matching quotes. Either single quotes ' or double quotes " can be used, but the opening and closing quotes must be the same.

## 6.2.6 Identifiers

Assembly identifiers are user-defined symbols representing memory locations or numbers. A symbol can contain any number of characters drawn from the alphabetic, numeric, and the special characters: dollar, \$; question mark, ?; and underscore, \_.

The first character of an identifier cannot be numeric. The case of alphabetic is significant, e.g., Fred is not the same symbol as fred. Some examples of identifiers are shown here:

```
An_identifier  
an_identifier  
an_identifier1  
$  
?$_12345
```

An identifier cannot be one of the assembler directives, keywords, or psect flags.

An identifier that begins with at least one underscore character can be accessed from C code. Care must be taken with such symbols that they do not interact with C code identifiers. Identifiers that do not begin with an underscore can only be accessed from the assembly domain. See [Section 5.12.3.1 "Equivalent Assembly Symbols"](#) for the mapping between the C and assembly domains.



## 6.2.6.1 SIGNIFICANCE OF IDENTIFIERS

Users of other assemblers that attempt to implement forms of data typing for identifiers should note that this assembler attaches no significance to any symbol, and places no restrictions or expectations on the usage of a symbol.

The names of psects (program sections) and ordinary symbols occupy separate, overlapping name spaces, but other than this, the assembler does not care whether a symbol is used to represent bytes, words or sports cars. No special syntax is needed or provided to define the addresses of bits or any other data type, nor will the assembler issue any warnings if a symbol is used in more than one context. The instruction and addressing mode syntax provide all the information necessary for the assembler to generate correct code.

## 6.2.6.2 ASSEMBLER-GENERATED IDENTIFIERS

Where a `LOCAL` directive is used in a macro block, the assembler will generate a unique symbol to replace each specified identifier in each expansion of that macro. These unique symbols will have the form `??nnnn` where `nnnn` is a 4-digit number. The user should avoid defining symbols with the same form.

## 6.2.6.3 LOCATION COUNTER

The current location within the active program section is accessible via the symbol `$`. This symbol expands to the address of the currently executing instruction (which is different than the address contained in the program counter (PC) register when executing this instruction). Thus:

```
GOTO $ ;endless loop
```

will represent code that will jump to itself and form an endless loop. By using this symbol and an offset, a relative jump destination can be specified.

Any address offset added to `$` has the native addressability of the target device. So, for baseline and mid-range devices, the offset is the number of instructions away from the current location, as these devices have word-addressable program memory. For PIC18 instructions, which use byte addressable program memory, the offset to this symbol represents the number of bytes from the current location. As PIC18 instructions must be word aligned, the offset to the location counter should be a multiple of 2. All offsets are rounded down to the nearest multiple of 2. For example:

```
GOTO $+2 ;skip...
MOVLW 8 ;to here for PIC18 devices, or
MOVWF _foo ;to here for baseline and mid-range devices
```

will skip the `MOVLW` instruction on baseline or mid-range devices. On PIC18 devices, `GOTO $+2` will jump to the following instruction; i.e., act like a `NOP` instruction.

## 6.2.6.4 REGISTER SYMBOLS

Code in assembly modules can gain access to the special function registers by including pre-defined assembly header files. The appropriate file can be included by add the line:

```
#include <xc.inc>
```

to the assembler source file. Note that the file must be included using a C pre-processor directive and hence the option to preprocess assembly files must be enabled when compiling, see [Section 4.8.10 “-P: Preprocess Assembly Files”](#). This header file contains appropriate commands to ensure that the header file specific for the target device is included into the source file.

These header files contain `EQU` declarations for all byte or multi-byte sized registers and `#define` macros for named bits within byte registers.

## 6.2.6.5 SYMBOLIC LABELS

A label is a symbolic alias that is assigned a value that is equal to the current address within the current psect. Labels are not assigned a value until link time.

A label definition consists of any valid assembly identifier followed by a *colon*, `:`. The definition can appear on a line by itself or it can be positioned before a statement. Here are two examples of legitimate labels interspersed with assembly code.

```
frank:
    MOVLW    1
    GOTO     fin
simon44: CLRF _input
```

Here, the label `frank` will ultimately be assigned the address of the `MOVLW` instruction, and `simon44` the address of the `CLRF` instruction. Regardless of how they are defined, the assembler list file produced by the assembler will always show labels on a line by themselves.

Note that the colon following the label is mandatory for PIC18 assembly, but is recommended in assembly for all other devices. Symbols that are not interpreted as instructions are assumed to be labels. Mistyped assembly instructions can sometimes be treated as labels without an error message being issued. Thus the code:

```
mistake:
    MOVLW 23h
    MOVWF 37h
    REUTRN      ; oops
```

defines a symbol called `REUTRN`, which was intended to be the `RETURN` instruction. This cannot occur with PIC18 assembly code, as the colon following a label is mandatory; the compiler would report an error when reached the line containing `REUTRN`.

Labels can be used (and are preferred) in assembly code, rather than using an absolute address with other instructions. In this way, they can be used as the target location for jump-type instructions or to load an address into a register.

Like variables, labels have scope. By default, they can be used anywhere in the module in which they are defined. They can be used by code located before their definition. To make a label accessible in other modules, use the `GLOBAL` directive. See [Section 6.2.9.1 "GLOBAL"](#) for more information.

## 6.2.7 Expressions

The operands to instructions and directives are comprised of expressions. Expressions can be made up of numbers, identifiers, strings and operators.

Operators can be unary (one operand, e.g., `not`) or binary (two operands, e.g., `+`). The operators allowable in expressions are listed in [Table 6-3](#).

**TABLE 6-3: ASPIC OPERATORS**

Operator	Purpose	Example
*	multiplication	<code>MOVLW 4*33,w</code>
+	addition	<code>BRA \$+1</code>
-	subtraction	<code>DB 5-2</code>
/	division	<code>MOVLW 100/4</code>
= or <code>eq</code>	equality	<code>IF inp eq 66</code>
> or <code>gt</code>	signed greater than	<code>IF inp &gt; 40</code>
>= or <code>ge</code>	signed greater than or equal to	<code>IF inp ge 66</code>
< or <code>lt</code>	signed less than	<code>IF inp &lt; 40</code>
<= or <code>le</code>	signed less than or equal to	<code>IF inp le 66</code>
<> or <code>ne</code>	signed not equal to	<code>IF inp &lt;&gt; 40</code>
<code>low</code>	low byte of operand	<code>MOVLW low(inp)</code>
<code>high</code>	high byte of operand	<code>MOVLW high(1008h)</code>
<code>highword</code>	high 16 bits of operand	<code>DW highword(inp)</code>
<code>mod</code>	modulus	<code>MOVLW 77mod4</code>
& or <code>and</code>	bitwise AND	<code>CLRF inp&amp;0ffh</code>
<code>^</code>	bitwise XOR (exclusive or)	<code>MOVF inp^80,w</code>
<code> </code>	bitwise OR	<code>MOVF inp 1,w</code>
<code>not</code>	bitwise complement	<code>MOVLW not 055h,w</code>
<< or <code>shl</code>	shift left	<code>DB inp&gt;&gt;8</code>
>> or <code>shr</code>	shift right	<code>MOVLW inp shr 2,w</code>
<code>rol</code>	rotate left	<code>DB inp rol 1</code>
<code>ror</code>	rotate right	<code>DB inp ror 1</code>
<code>float24</code>	24-bit version of real operand	<code>DW float24(3.3)</code>
<code>nul</code>	tests if macro argument is null	

The usual rules governing the syntax of expressions apply.

The operators listed can all be freely combined in both constant and relocatable expressions. The linker permits relocation of complex expressions, so the results of expressions involving relocatable identifiers cannot be resolved until link time.

## 6.2.8 Program Sections

Program sections, or psects, are simply a section of code or data. They are a way of grouping together parts of a program (via the psect's name) even though the source code cannot be physically adjacent in the source file, or even where spread over several modules. For an introductory guide to psects, see [Section 5.15.1 “Program Sections”](#).

A psect is identified by a name and has several attributes. The `PSECT` assembler directive is used to define a psect. It takes as arguments a name and an optional *comma*-separated list of flags. See [Section 5.15.2 “Compiler-Generated Psects”](#) for a list of all psects that the code generator defines. [Chapter 7. Linker](#) has more information on the operation of the linker and on options that can be used to control psect placement in memory.

The assembler associates no significance to the name of a psect. The linker, also, is not aware of which psects are compiler-generated or which are user-defined. Unless defined as `abs` (absolute), psects are relocatable.

Code or data that is not explicitly placed into a psect will become part of the default (unnamed) psect.

When writing assembly code, you can use the existing compiler-generated psects, described in [Section 5.15.2 “Compiler-Generated Psects”](#), or create your own. You will not need to adjust the linker options if you are using compiler-generated psects. If you create your own psects, try to associate them with an existing linker class (see [Section 5.15.3 “Default Linker Classes”](#) and [Section 6.2.9.3.3 “Class”](#)) otherwise you can need to specify linker options for them to be allocated correctly.

Note, that the length and placement of psects is important. It is easier to write code if all executable code is located in psects that do not cross any device pages boundaries; so, too, if data psects do not cross bank boundaries. The location of psects (where they are linked) must match the assembly code that accesses the psect contents.

## 6.2.9 Assembler Directives

Assembler directives, or pseudo-ops, are used in a similar way to instruction mnemonics. With the exception of `PAGESEL` and `BANKSEL`, these directives do not generate instructions. The `DB`, `DW` and `DDW` directives place data bytes into the current psect. The directives are listed in [Table 6-4](#), and are detailed below in the following sections.

**TABLE 6-4: ASPIC ASSEMBLER DIRECTIVES**

Directive	Purpose
GLOBAL	make symbols accessible to other modules or allow reference to other global symbols defined in other modules
END	end assembly
PSECT	declare or resume program section
ORG	set location counter within current psect
EQU	define symbol value
EXTRN	link with global symbols defined in other modules
SET	define or re-define symbol value
DB	define constant byte(s)
DW	define constant word(s)
DDW	define double-width constant word(s) (PIC18 devices only)
DS	reserve storage
DABS	define absolute storage
IF	conditional assembly
ELSIF	alternate conditional assembly
ELSE	alternate conditional assembly
ENDIF	end conditional assembly
FNCALL	inform the linker that one function calls another
FNROOT	inform the linker that a function is the “root” of a call graph
MACRO	macro definition
ENDM	end macro definition
LOCAL	define local tabs
ALIGN	align output to the specified boundary
BANKSEL	generate code to select bank of operand
PAGESEL	generate set/clear instruction to set <code>PCLATH</code> bits for this page
PROCESSOR	define the particular chip for which this file is to be assembled.
REPT	repeat a block of code <i>n</i> times
IRP	repeat a block of code with a list
IRPC	repeat a block of code with a character list
SIGNAT	define function signature

## 6.2.9.1 GLOBAL

The `GLOBAL` directive declares a list of comma-separated symbols. If the symbols are defined within the current module, they are made public. If the symbols are not defined in the current module, they are made references to public symbols defined in external modules. Thus to use the same symbol in two modules the `GLOBAL` directive must be used at least twice: once in the module that defines the symbol to make that symbol public, and again in the module that uses the symbol to link in with the external definition.

For example:

```
GLOBAL lab1,lab2,lab3
```

## 6.2.9.2 END

The `END` directive is optional, but if present should be at the very end of the program. It will terminate the assembly and not even blank lines should follow this directive.

If an expression is supplied as an argument, that expression will be used to define the entry point of the program. This is stored in a start record in the object file produced by the assembler. Whether this is of any use will depend on the linker.

The default runtime startup code that is defined by the compiler will contain an `END` directive with a start address. As only one start address can be specified for each project, you generally do not need to define this address – you can use the `END` directive with no entry point in any file.

For example:

```
END start_label ;defines the entry point
```

or

```
END ;do not define entry point
```

## 6.2.9.3 PSECT

The `PSECT` directive declares or resumes a program section. For an introductory guide to psects, see [Section 5.15.1 “Program Sections”](#).

The directive takes as argument a name and, optionally, a *comma*-separated list of flags. The allowed flags specify attributes of the psect. They are listed in [Table 6-5](#).

The psect name is in a separate name space to ordinary assembly symbols, so a psect can use the same identifier as an ordinary assembly identifier. However, a psect name cannot be one of the assembler directives, keywords, or psect flags.

Once a psect has been declared, it can be resumed later by another `PSECT` directive; however, the flags need not be repeated and will be propagated from the earlier declaration. If two `PSECT` directives are encountered with contradicting flags, then an error is generated.

**TABLE 6-5: PSECT FLAGS**

Flag	Meaning
<code>abs</code>	psect is absolute
<code>bit</code>	psect holds bit objects
<code>class=name</code>	specify class name for psect
<code>delta=size</code>	size of an addressing unit
<code>global</code>	psect is global (default)
<code>inline</code>	psect contents (function) can be inlined when called
<code>keep</code>	psect will not be deleted after inlining
<code>limit=address</code>	upper address limit of psect
<code>local</code>	psect is unique and will not link with others having the same name
<code>lowdata</code>	psect will be entirely located below the 0x1000 address
<code>merge=allow</code>	allow or prevent merging of this psect
<code>noexec</code>	for debugging purposes, this psect contains no executable code
<code>optim=optimizations</code>	specify optimizations allowable with this psect
<code>ovrld</code>	psect will overlap same psect in other modules
<code>pure</code>	psect is to be read-only
<code>reloc=boundary</code>	start psect on specified boundary
<code>size=max</code>	maximum size of psect
<code>space=area</code>	represents area in which psect will reside
<code>split=allow</code>	allow or prevent splitting of this psect
<code>with=psect</code>	place psect in the same page as specified psect

Some examples of the use of the `PSECT` directive follow:

```
PSECT fred
PSECT bill, size=100h, global
PSECT joh, abs, ovrld, class=CODE, delta=2
```

## 6.2.9.3.1 Abs

The `abs` flag defines the current psect as being absolute; i.e., it is to start at location 0. This does not mean that this module's contribution to the psect will start at 0, since other modules can contribute to the same psect. See also [Section 6.2.9.3.13 "Ovrlid"](#).

An `abs`-flagged psect is not relocatable and an error will result if a linker option is issued that attempts to place such a psect at any location.

## 6.2.9.3.2 Bit

The `bit` flag specifies that a psect holds objects that are 1 bit long. Such psects will have a `scale` value of 8 to indicate that there are 8 addressable units to each byte of storage and all addresses associated with this psect will be bit address, not byte addresses. The scale value is indicated in the map file; see [Section 7.4 "Map Files"](#).

## 6.2.9.3.3 Class

The `class` flag specifies a corresponding linker class name for this psect. A class is a range of addresses in which psects can be placed.

Class names are used to allow local psects to be located at link time, since they cannot always be referred to by their own name in a `-P` linker option (as would be the case if there are more than one local psect with the same name).

Class names are also useful where psects need only be positioned anywhere within a range of addresses rather than at a specific address. The association of a class with a psect that you have defined typically means that you do not need to supply a custom linker option to place it in memory.

See [Section 7.2.1 "-Aclass =low-high,..."](#) for information on how linker classes are defined.

## 6.2.9.3.4 Delta

The `delta` flag defines the size of the addressable unit. In other words, the number of data bytes that are associated with each address.

With PIC mid-range and baseline devices, the program memory space is word addressable; so, psects in this space must use a delta of 2. That is to say, each address in program memory requires 2 bytes of data in the HEX file to define their contents. So, addresses in the HEX file will not match addresses in the program memory.

The data memory space on these devices is byte addressable; so, psects in this space must use a delta of 1. This is the default delta value.

All memory spaces on PIC18 devices are byte addressable; so, a delta of 1 (the default) should be used for all psects on these devices.

The redefinition of a psect with conflicting delta values can lead to phase errors being issued by the assembler.

## 6.2.9.3.5 Global

A psect defined as `global` will be combined with other `global` psects with the same name at link time. Psects are grouped from all modules being linked.

Psects are considered `global` by default, unless the `local` flag is used.



## 6.2.9.3.6 Inline

This flag is deprecated. Consider, instead, using the `optim psect` flag.

The `inline` flag is used by the code generator to tell the assembler that the contents of a psect can be inlined. If this operation is performed, the contents of the `inline` psect will be copied and used to replace calls to the function defined in the psect.

## 6.2.9.3.7 Keep

This flag is deprecated. Consider, instead, using the `optim psect` flag.

Psects that are candidates for inlining (see [Section 6.2.9.3.6 “Inline”](#)) can be deleted after the inlining takes place. This flag ensures that the psect is not deleted after any inlining by the assembler optimizer.

## 6.2.9.3.8 Limit

The `limit` flag specifies a limit on the highest address to which a psect can extend. If this limit is exceeded when it is positioned in memory, an error will be generated.

## 6.2.9.3.9 Local

A psect defined as `local` will not be combined with other `local` psects from other modules at link time, even if there are others with the same name. Where there are two `local` psects in the one module, they reference the same psect. A `local` psect cannot have the same name as any `global` psect, even one in another module.

Psects which are local and which are not associated with a linker class (see [Section 6.2.9.3.3 “Class”](#)) cannot be linked to an address using the `-P` linker option, since there could be more than one psect with this name. Typically a class is specified with these psects and they are placed anywhere in the memory range associated with that class.

## 6.2.9.3.10 Merge

This flag is deprecated. Consider, instead, using the `optim psect` flag.

This flag can be assigned 0, 1, or not specified. When assigned 0, the psect will never be merged by the assembly optimizer during optimizations. If assigned the value 1, the psect can be merged if other psect attributes allow it and the optimizer can see an advantage in doing so. If this flag is not specified, then merging will not take place.

Typically, merging is only performed on code-based psects (text psects).

## 6.2.9.3.11 Noexec

The `noexec` flag is used to indicate that the psect contains no executable code. This information is only relevant for debugging purposes and does not affect the assembler output.

## 6.2.9.3.12 Optim

The `optim` psect flag can be used to indicate the optimizations that can be performed on the psect. The optimizations are indicated by a colon-separated list of names. An empty list implies that no optimizations can be performed on the psect contents. The allowable optimizations will be performed on the psect if that optimization is available in the compiler's operating mode, and the assembler optimizer is enabled (see [Section 4.8.45 "--OPT: Invoke Compiler Optimizations"](#)). The available optimizations are shown in [Table 6-6](#).

**TABLE 6-6: OPTIM FLAG NAMES**

Name	Optimization
<code>inline</code>	allow the psect content to be inlined
<code>jump</code>	perform jump-based optimizations
<code>merge</code>	allow the psect's content to be merged with that of other similar psects (PIC10/12/16 devices only)
<code>pa</code>	perform procedural abstraction
<code>peep</code>	perform peephole optimizations
<code>remove</code>	allow the psect to be removed entirely if it is completely inlined
<code>split</code>	allow the psect to be split into smaller psects if it surpasses size restrictions (PIC10/12/16 devices only)
<code>empty</code>	perform no optimization on this psect

So, for example, the psect definition:

```
PSECT myText, class=CODE, reloc=2, optim=inline:jump:split
```

allows the assembler optimizer to perform inlining, splitting and jump-type optimizations of the `myText` psect content if those optimizations are enabled. The definition:

```
PSECT myText, class=CODE, reloc=2, optim=
```

disables all optimizations associated with this psect regardless of the optimizer setting.

The `optim` psect flag replaces the use of the separate psect flags: `merge`, `split`, `inline`, and `keep`.

## 6.2.9.3.13 OvrlD

A psect defined as `ovrlD` will have the contribution from each module overlaid, rather than concatenated at link time. This flag in combination with the `abs` flag (see [Section 6.2.9.3.1 "Abs"](#)) defines a truly absolute psect; i.e., a psect within which any symbols defined are absolute.

## 6.2.9.3.14 Pure

The `pure` flag instructs the linker that this psect will not be modified at runtime. So, for example, be placed in ROM. This flag is of limited usefulness since it depends on the linker and target system enforcing it.

## 6.2.9.3.15 Reloc

The `reloc` flag allows the specification of a requirement for alignment of the psect on a particular boundary. The boundary specification must be a power of two, for example 2, 8 or 0x40. For example, the flag `reloc=100h` would specify that this psect must start on an address that is a multiple of 0x100 (e.g. 0x100, 0x400, or 0x500).

PIC18 instructions must be word aligned, so a `reloc` value of 2 must be used for any PIC18 psect that contains executable code. All other sections, and all sections for all other devices, can typically use the default `reloc` value of 1.

## 6.2.9.3.16 Size

The `size` flag allows a maximum size to be specified for the psect, e.g., `size=100h`. This will be checked by the linker after psects have been combined from all modules.

## 6.2.9.3.17 Space

The `space` flag is used to differentiate areas of memory that have overlapping addresses, but are distinct. Psects that are positioned in program memory and data memory have a different `space` value to indicate that the program space address 0, for example, is a different location to the data memory address 0.

The memory spaces associated with the space flag numbers are shown in [Table 6-7](#).

**TABLE 6-7: SPACE FLAG NUMBERS**

Space Flag Number	Memory Space
0	Program memory
1	Data memory
2	Reserved
3	EEPROM

Devices that have a banked data space do not use different space values to identify each bank. A full address that includes the bank number is used for objects in this space. So, each location can be uniquely identified. For example, a device with a bank size of 0x80 bytes will use address 0 to 0x7F to represent objects in bank 0, and then addresses 0x80 to 0xFF to represent objects in bank 1, etc.

## 6.2.9.3.18 Split

This flag is deprecated. Consider, instead, using the `optim` psect flag.

This flag can be assigned 0, 1, or not specified. When assigned 0, the psect will never be split by the assembly optimizer during optimizations. If assigned the value 1, the psect can be split if other psect attributes allow it and the psect is too large to fit in available memory. If this flag is not specified, then the splitability of this psect is based on whether the psect can be merged, see [Section 6.2.9.3.10 “Merge”](#).

## 6.2.9.3.19 With

The `with` flag allows a psect to be placed in the same page with another psect. For example the flag `with=text` will specify that this psect should be placed in the same page as the `text` psect.

The term *withtotal* refers to the sum of the size of each psect that is placed “with” other psects.

## 6.2.9.4 ORG

The `ORG` directive changes the value of the location counter within the current psect. This means that the addresses set with `ORG` are relative to the base address of the psect, which is not determined until link time.

**Note:** The much-abused `ORG` directive does *not* move the location counter to the absolute address you specify. Only if the psect in which this directive is placed is absolute and overlaid will the location counter be moved to the address specified. To place objects at a particular address, place them in a psect of their own and link this at the required address using the linker's `-P` option, see [Section 7.2.18 “-Pspec”](#). The `ORG` directive is not commonly required in programs.

The argument to `ORG` must be either an absolute value, or a value referencing the current psect. In either case, the current location counter is set to the value determined by the argument. It is not possible to move the location counter backward. For example:

```
ORG 100h
```

will move the location counter to the beginning of the current psect plus 100h. The actual location will not be known until link time.

In order to use the `ORG` directive to set the location counter to an absolute value, the directive must be used from within an absolute, overlaid psect. For example:

```
PSECT absdata,abs,ovrld
    ORG 50h
    ;this is guaranteed to reside at address 50h
```

## 6.2.9.5 EQU

This pseudo-op defines a symbol and equates its value to an expression. For example

```
thomas EQU 123h
```

The identifier `thomas` will be given the value 123h. `EQU` is legal only when the symbol has not previously been defined. See also, [Section 6.2.9.7 “SET”](#), which allows for redefinition of values.

This directive performs a similar function to the preprocessor's `#define` directive, see [Section 5.14.1 “C Language Comments”](#).

## 6.2.9.6 EXTRN

This pseudo-op is similar to `GLOBAL` (see [Section 6.2.9.1 “GLOBAL”](#)), but can only be used to link in with global symbols defined in other modules. An error will be triggered if you use `EXTRN` with a symbol that is defined in the same module.

## 6.2.9.7 SET

This pseudo-op is equivalent to `EQU` ([Section 6.2.9.5 “EQU”](#)), except that allows a symbol to be re-defined without error. For example:

```
thomas SET 0h
```

This directive performs a similar function to the preprocessor's `#define` directive, see [Section 5.14.1 “C Language Comments”](#).

## 6.2.9.8 DB

The `DB` directive is used to initialize storage as bytes. The argument is a *comma-separated* list of expressions, each of which will be assembled into one byte and assembled into consecutive memory locations.

Examples:

```
alabel: DB 'X',1,2,3,4,
```

If the size of an address unit in the program memory is 2 bytes, as it will be for baseline and mid-range devices (see [Section 6.2.9.3.4 “Delta”](#)), the `DB` pseudo-op will initialize a word with the upper byte set to zero. So, the above example will define bytes padded to the following words.

```
0058 0001 0002 0003 0004
```

However, on PIC18 devices (`PSECT` directive's `delta` flag should be 1), no padding will occur and the following data will appear in the HEX file.

```
58 01 02 03 04
```

## 6.2.9.9 DW

The `DW` directive operates in a similar fashion to `DB`, except that it assembles expressions into 16-bit words. Example:

```
DW -1, 3664h, 'A'
```

## 6.2.9.10 DDW

The `DDW` directive operates in a similar fashion to `DW`, except that it assembles expressions into double-width (32-bit) words. Example:

```
DDW 'd', 12345678h, 0
```

## 6.2.9.11 DS

This directive reserves, but does not initialize, memory locations. The single argument is the number of bytes to be reserved.

This directive is typically used to reserve memory location for RAM-based objects in the data memory. If used in a `psect` linked into the program memory, it will move the location counter, but not place anything in the HEX file output. Note that because the size of an address unit in the program memory is 2 bytes (see [Section 6.2.9.3.4 “Delta”](#)), the `DS` pseudo-op will actually reserve an entire word.

A variable is typically defined by using a label and then the `DS` directive to reserve locations at the label location.

Examples:

```
alabel: DS 23      ;Reserve 23 bytes of memory
xlabel: DS 2+3    ;Reserve 5 bytes of memory
```

## 6.2.9.12 DABS

This directive allows one or more bytes of memory to be reserved at the specified address. The general form of the directive is:

```
DABS memorySpace, address, bytes[ ,symbol]
```

where *memorySpace* is a number representing the memory space in which the reservation will take place, *address* is the address at which the reservation will take place, and *bytes* is the number of bytes that is to be reserved. The *symbol* is optional and refers to the name of the object at the address.

Use of *symbol* in the directive will aid debugging. The symbol is automatically made globally accessible and is equated to the address specified in the directive. So, for example, the following directive uses a symbol:

```
DABS 1,0x100,4,foo
```

that is identical to the following directives:

```
GLOBAL foo
foo EQU 0x100
DABS 1,0x100,4
```

This directive differs to the `DS` directive in that it can be used to reserve memory at any location, not just within the current psect. Indeed, these directives can be placed anywhere in the assembly code and do not contribute to the currently selected psect in any way.

The memory space number is the same as the number specified with the `space` flag option to psects (see [Section 6.2.9.3.17 "Space"](#)).

The code generator issues a `DABS` directive for every user-defined absolute C variable, or for any variables that have been allocated an address by the code generator.

The linker reads this `DABS`-related information from object files and ensures that the reserved addresses are not used for other memory placement.

## 6.2.9.13 IF, ELSIF, ELSE AND ENDIF

These directives implement conditional assembly. The argument to `IF` and `ELSIF` should be an absolute expression. If it is non-zero, then the code following it up to the next matching `ELSE`, `ELSIF` or `ENDIF` will be assembled. If the expression is zero, then the code up to the next matching `ELSE` or `ENDIF` will not be output.

At an `ELSE`, the sense of the conditional compilation will be inverted, while an `ENDIF` will terminate the conditional assembly block.

These directives do not implement a runtime conditional statement in the same way that the C statement `if()` does; they are only evaluated at compile time. In addition, assembly code in both true and false cases is always scanned and interpreted, but the machine code corresponding to instructions is *output* only if the condition matches. This implies that assembler directives (e.g., `EQU`) will be processed regardless of the state of the condition expression, and so, should not be used inside an `IF` construct.

For example:

```
IF ABC
    GOTO aardvark
ELSIF DEF
    GOTO denver
ELSE
    GOTO grapes
ENDIF
ENDIF
```

In this example, if `ABC` is non-zero, the first `GOTO` instruction will be assembled but not the second or third. If `ABC` is zero and `DEF` is non-zero, the second `GOTO` instruction will be assembled but the first and third will not. If both `ABC` and `DEF` are zero, the third `GOTO` instruction will be assembled. Note in the above example, only one `GOTO` instruction will appear in the output; which one will be determined by the values assigned to `ABC` and `DEF`.

Conditional assembly blocks can be nested.

#### 6.2.9.14 MACRO AND ENDM

These directives provide for the definition of assembly macros, optionally with arguments. See [Section 6.2.9.5 “EQU”](#) for simple association of a value with an identifier, or [Section 5.14.1 “C Language Comments”](#) for the preprocessor’s `#define` macro directive, which can also work with arguments.

The `MACRO` directive should be preceded by the macro name and optionally followed by a *comma*-separated list of formal arguments. When the macro is used, the macro name should be used in the same manner as a machine opcode, followed by a list of arguments to be substituted for the formal parameters.

For example:

```
;macro: movlf
;args:  arg1 - the literal value to load
;       arg2 - the NAME of the source variable
;descr: Move a literal value into a nominated file register

movlf  MACRO  arg1,arg2
        MOVLW arg1
        MOVWF arg2 mod 080h
ENDM
```

When used, this macro will expand to the 2 instructions in the body of the macro, with the formal parameters substituted by the arguments. Thus:

```
movlf 2,tempvar
```

expands to:

```
MOVLW 2
MOVWF tempvar mod 080h
```

The `&` character can be used to permit the concatenation of macro arguments with other text, but is removed in the actual expansion. For example:

```
loadPort MACRO port, value
        MOVLW value
        MOVWF PORT&port
ENDM
```

will load `PORTA` if `port` is `A` when called, etc. The special meaning of the `&` token in macros implies that you can not use the bitwise AND operator, (also represented by `&`), in assembly macros; use the `and` form of this operator instead.

A comment can be suppressed within the expansion of a macro (thus saving space in the macro storage) by opening the comment with a double semicolon, `;;`.

When invoking a macro, the argument list must be *comma*-separated. If it is desired to include a *comma* (or other delimiter such as a space) in an argument then angle brackets `<` and `>` can be used to quote

If an argument is preceded by a percent sign, `%`, that argument will be evaluated as an expression and passed as a decimal number, rather than as a string. This is useful if evaluation of the argument inside the macro body would yield a different result.

The `nul` operator can be used within a macro to test a macro argument, for example:

```
IF nul      arg3 ; argument was not supplied.
    ...
ELSE        ; argument was supplied
    ...
ENDIF
```

See [Section 6.2.9.15 “LOCAL”](#) for use of unique local labels within macros.

By default, the assembly list file will show macro in an unexpanded format; i.e., as the macro was invoked. Expansion of the macro in the listing file can be shown by using the `EXPAND` assembler control; see [Section 6.2.10.4 “EXPAND”](#).

## 6.2.9.15 LOCAL

The `LOCAL` directive allows unique labels to be defined for each expansion of a given macro. Any symbols listed after the `LOCAL` directive will have a unique assembler generated symbol substituted for them when the macro is expanded. For example:

```
down MACRO count
    LOCAL more
    more: DECFSZ count
    GOTO more
ENDM
```

when expanded, will include a unique assembler generated label in place of `more`. For example:

```
down foobar
```

expands to:

```
??0001 DECFSZ foobar
    GOTO ??0001
```

If invoked a second time, the label `more` would expand to `??0002`, and multiply defined symbol errors will be averted.

## 6.2.9.16 ALIGN

The `ALIGN` directive aligns whatever is following, data storage or code etc., to the specified offset boundary within the current psect. The boundary is specified as a number of bytes following the directive.

For example, to align output to a 2-byte (even) address within a psect, the following could be used.

```
ALIGN 2
```

Note that what follows will only begin on an even absolute address if the psect begins on an even address; i.e., alignment is done within the current psect. See [Section 6.2.9.3.15 “Reloc”](#) for psect alignment.

The `ALIGN` directive can also be used to ensure that a psect's length is a multiple of a certain number. For example, if the above `ALIGN` directive was placed at the end of a psect, the psect would have a length that was always an even number of bytes long.



## 6.2.9.17 REPT

The `REPT` directive temporarily defines an unnamed macro, then expands it a number of times as determined by its argument.

For example:

```
REPT 3
    ADDWF fred,w
ENDM
```

will expand to:

```
    ADDWF fred,w
    ADDWF fred,w
    ADDWF fred,w
```

See also, [Section 6.2.9.18 “IRP and IRPC”](#).

## 6.2.9.18 IRP AND IRPC

The `IRP` and `IRPC` directives operate in a similar way to `REPT`; however, instead of repeating the block a fixed number of times, it is repeated once for each member of an argument list.

In the case of `IRP`, the list is a conventional macro argument list. In the case of `IRPC`, it is each character in one argument. For each repetition, the argument is substituted for one formal parameter.

For example:

```
IRP number,4865h,6C6Ch,6F00h
    DW number
ENDM
```

would expand to:

```
    DW 4865h
    DW 6C6Ch
    DW 6F00h
```

Note that you can use local labels and angle brackets in the same manner as with conventional macros.

The `IRPC` directive is similar, except it substitutes one character at a time from a string of non-space characters.

For example:

```
IRPC char,ABC
    DB 'char'
ENDM
```

will expand to:

```
    DB 'A'
    DB 'B'
    DB 'C'
```

## 6.2.9.19 BANKSEL

This directive can be used to generate code to select the bank of the operand. The operand should be the symbol or address of an object that resides in the data memory. See [Section 6.2.1.2 “Bank and Page Selection”](#).

## 6.2.9.20 PAGESEL

This directive can be used to generate code to select the page of the address operand. See [Section 6.2.1.2 “Bank and Page Selection”](#).

## 6.2.9.21 PROCESSOR

The output of the assembler can vary, depending on the target device. The device name is typically set using the `--CHIP` option to the command-line driver `xc8`, see [Section 4.8.18 “--CHIP: Define Device”](#). However, it can also be set with this directive, for example:

```
PROCESSOR 16F877
```

This directive will override any device selected by any command-line option.

## 6.2.9.22 SIGNAT

This directive is used to associate a 16-bit signature value with a label. At link time, the linker checks that all signatures defined for a particular label are the same. The linker will produce an error if they are not. The `SIGNAT` directive is used by MPLAB XC8 to enforce link time checking of C function prototypes and calling conventions.

Use the `SIGNAT` directive if you want to write assembly language routines that are called from C. For example:

```
SIGNAT _fred,8192
```

associates the signature value 8192 with the symbol `_fred`. If a different signature value for `_fred` is present in any object file, the linker will report an error.

The easiest way to determine the correct signature value for a routine is to write a C routine with the same prototype as the assembly routine and check the signature value determined by the code generator. This will be shown in the assembly list file; see [Section 4.8.15 “--ADDRQUAL: Set Compiler Response to Memory Qualifiers”](#), and [Section 6.3 “Assembly-Level Optimizations”](#).

## 6.2.10 Assembler Controls

Assembler controls can be included in the assembler source to control assembler operation. These keywords have no significance anywhere else in the program. The control is invoked by the directive `OPT`, followed by the control name. Some keywords are followed by one or more arguments. For example:

```
OPT EXPAND
```

A list of keywords is given in [Table 6-8](#), and each is described in the text that follows the table.

**TABLE 6-8: ASPIC ASSEMBLER CONTROLS<sup>(1)</sup>**

Control	Meaning	Format
ASMOPT_ON, ASMOPT_OFF	start and stop assembly optimizations	OPT ASMOPT_OFF ;protected code OPT ASMOPT_ON
ASMOPT_PUSH, ASMOPT_POP	save and restore the state of the assembly optimizations	OPT ASMOPT_PUSH ;save state OPT ASMOPT_OFF ;protected code OPT ASMOPT_POP ;restore state
COND*, NOCOND	include/do not include conditional code in the listing	OPT COND
EXPAND, NOEXPAND	expand/do not expand macros in the listing output	OPT EXPAND
INCLUDE	textually include another source file	OPT INCLUDE < <i>pathname</i> >
LIST*, NOLIST	define options for listing output/disable listing output	OPT LIST [< <i>listopt</i> >, ..., < <i>listopt</i> >]
PAGE	start a new page in the listing output	OPT PAGE
SPACE	add blank lines to listing	OPT SPACE 3
SUBTITLE	specify the subtitle of the program	OPT SUBTITLE "< <i>subtitle</i> >"
TITLE	specify the title of the program	OPT TITLE "< <i>title</i> >"

**Note 1:** The default options are listed with an asterisk (\*)

### 6.2.10.1 ASMOPT\_OFF AND ASMOPT\_ON

These controls allow the assembler optimizer to be selectively disabled for sections of assembly code. No code is modified after an `ASMOPT_OFF` control until a subsequent `ASMOPT_ON` control is encountered.

### 6.2.10.2 ASMOPT\_PUSH AND ASMOPT\_POP

These controls allow the state of the assembler optimizer to be saved onto a stack of states and then restored at a later time. They are useful when you need to ensure the optimizers are disabled for a small section of code, but you do not know if the optimizers have previously been disabled. See [Table 6-8](#) for an example of how these might be used.

### 6.2.10.3 COND

Any conditional code is included in the listing output. See also, the `NOCOND` control in [Section 6.2.10.7 "NOCOND"](#).

## 6.2.10.4 EXPAND

When `EXPAND` is in effect, the code generated by macro expansions appears in the listing output. See also, the `NOEXPAND` control in [Section 6.2.10.8 “NOEXPAND”](#).

## 6.2.10.5 INCLUDE

This control causes the file specified by *pathname* to be textually included at that point in the assembly file. The `INCLUDE` control must be the last control keyword on the line, for example:

```
OPT INCLUDE "options.h"
```

The driver does not pass any search paths to the assembler, so if the include file is not located in the working directory, the *pathname* must specify the exact location.

See also, the driver option `-P` in ([Section 4.8.10 “-P: Preprocess Assembly Files”](#)) that forces the C preprocessor to preprocess the assembly file, thus allowing use of preprocessor directives, such as `#include` (see [Section 5.14.1 “C Language Comments”](#)).

## 6.2.10.6 LIST

If, previously, the listing was turned off using the `NOLIST` control, the `LIST` control automatically turns listing on.

Alternatively, the `LIST` control can include options to control the assembly and the listing. The options are listed in [Table 6-9](#).

**TABLE 6-9: LIST CONTROL OPTIONS**

List Option	Default	Description
<code>c= nnn</code>	80	Set the page (i.e., column) width.
<code>n= nnn</code>	59	Set the page length.
<code>t= ON OFF</code>	OFF	Truncate listing output lines. The default wraps lines.
<code>p=&lt; device &gt;</code>	n/a	Set the device type.
<code>r=&lt; radix &gt;</code>	HEX	Set the default radix to HEX, dec or oct.
<code>x= ON OFF</code>	OFF	Turn macro expansion on or off.

See also, the `NOLIST` control in [Section 6.2.10.9 “NOLIST”](#).

## 6.2.10.7 NOCOND

Using this control will prevent conditional code from being included in the assembly list file output. See also, the `COND` control in [Section 6.2.10.3 “COND”](#).

## 6.2.10.8 NOEXPAND

The `NOEXPAND` control disables macro expansion in the assembly list file. The macro call will be listed instead. See the `EXPAND` control in [Section 6.2.10.4 “EXPAND”](#). Assembly macros are discussed in [Section 6.2.9.14 “MACRO and ENDM”](#).

## 6.2.10.9 NOLIST

This control turns the listing output off from a precise point forward. See also, the `LIST` control in [Section 6.2.10.6 “LIST”](#).

## 6.2.10.10 PAGE

The `PAGE` control causes a new page to be started in the listing output. A Control-L (form feed) character will also cause a new page when it is encountered in the source.

## 6.2.10.11 SPACE

The `SPACE` control places a number of blank lines in the listing output, as specified by its parameter.

## 6.2.10.12 SUBTITLE

The `SUBTITLE` control defines a subtitle to appear at the top of every listing page, but under the title. The string should be enclosed in single or double quotes. See also, the `TITLE` control in [Section 6.2.10.13 "TITLE"](#).

## 6.2.10.13 TITLE

This control keyword defines a title to appear at the top of every listing page. The string should be enclosed in single or double quotes. See also, the `SUBTITLE` control in [Section 6.2.10.12 "SUBTITLE"](#).

## 6.3 ASSEMBLY-LEVEL OPTIMIZATIONS

The assembler performs optimizations on assembly code, in addition to those optimizations performed by the code generator directly on the C code; see [Section 5.13 “Optimizations”](#).

The assembler only optimizes hand-written assembly source modules if the `asmfile` optimization setting is enabled, see [Section 4.8.45 “--OPT: Invoke Compiler Optimizations”](#). Assembly added in-line (see [Section 5.12.2 “#asm, #endasm and asm\( \)”](#)) with C code is never optimized.

The optimizations that can be performed by the assembler include the following. Note, however, that these optimizations are skipped if the compiler is operating in Free mode (unless indicated below). The compiler operating mode selection is made by an option, see [Section 4.8.39 “--MODE: Choose Compiler Operating Mode”](#).

Assembly-level optimizations include:

- **In-lining of small routines** is done so that a call to the routine is not required. Only very small routines (typically a few instructions) that are called only once will be changed so that code size is not adversely impacted. This speeds code execution without a significant increase in code size.
- **Explicit inlining of functions** that use the `inline` specifier, see [Section 5.8.1.2 “Inline Specifier”](#).
- **Procedural abstraction** is performed on assembly code sequences that appear more than once. This is essentially a reverse in-lining process. The code sequences are abstracted into callable routines that use a label, `PLx`, where `x` is a number. A call to this routine will replace every instance of the original code sequence. This optimization reduces code size considerably, with a small impact on code speed. It can, however, adversely impact debugging. Procedural abstraction is only employed by compilers operating in PRO mode.
- **Jump-to-jump type optimizations** are made primarily to tidy the output related to conditional code sequences that follow a generic template. Jump-to-jump optimizations can remove jump instructions whose destinations are also jump instructions. This optimization is enabled in all modes, including Free mode.
- **Unreachable code is removed**. Code can become orphaned by other optimizations and cannot be reached during normal execution, e.g., instructions after a return instruction. The presence of any label is considered a possible entry point, and code following a label is always considered reachable.
- **Peephole optimizations** are performed on every instruction. These optimizations consider the state of execution at, and immediately around, each instruction – hence the name. They either alter or delete one or more instructions at each step. For example, if `W` is known to contain the value 0, and an instruction moves `W` to an address (`MOVWF`), this might be replaceable with a `CLRF` instruction.
- **Psect merging** can be performed to allow other optimizations to take place. Code within the same psect is guaranteed to be located in the same program memory page. So, calls and jumps within the psect do not need to have the page selection bits set before executing. Code using the `LJMP` and `FCALL` instructions will benefit from this optimization, see [Section 6.2.1 “Assembly Instruction Deviations”](#).

Assembly optimizations can often interfere with debugging in some tools, such as MPLAB X IDE. It can be necessary to disable them when debugging code, if that is possible. See [Section 4.8.45 “--OPT: Invoke Compiler Optimizations”](#), for more details. The assembler optimizations can drastically reduce code size. However, they typically have little effect on RAM usage.

## 6.4 ASSEMBLY LIST FILES

The assembler will produce an assembly list file if instructed. The `xc8` driver option `--ASMLIST` is typically used to request generation of such a file, see [Section 4.8.16 “--ASMLIST: Generate Assembler List Files”](#).

The assembly list file shows the assembly output produced by the compiler for both C and assembly source code. If the assembler optimizers are enabled, the assembly output can be different than assembly source code. So, it is still useful for assembly programming.

The list file is in a human-readable form and cannot be go any farther in the compilation sequence. It differs from an assembly output file in that it contains address and op-code data. In addition, the assembler optimizer simplifies some expressions and removes some assembler directives from the listing file for clarity, although these directives are included in the true assembly output files. If you are using the assembly list file to look at the code produced by the compiler, you might wish to turn off the assembler optimizer so that all the compiler-generated directives are shown in the list file. Re-enable the optimizer when continuing development. [Section 4.8.45 “--OPT: Invoke Compiler Optimizations”](#) gives more information on controlling the optimizers.

Provided that the link stage has successfully concluded, the listing file is updated by the linker so that it contains absolute addresses and symbol values. Thus, you can use the assembler list file to determine the position and exact op codes of instructions.

Tick marks “`'`” in the assembly listing, next to addresses or opcodes, indicate that the linker did not update the list file, most likely due to a compiler error, or a compiler option that stopped compilation before the link stage. For example, in the following listing:

```
85  000A' 027F          subwf   127,w
86  000B' 1D03          skipz
87  000C' 2800'        goto   u15
```

These marks indicate that addresses are just address offsets into their enclosing psect, and that opcodes have not been fixed up. Any address field in the opcode that has not been fixed up is shown with a value of 0.

There is a single assembly list file produced by the assembler for each assembly file passed to it. So, there is a single file produced for all the C source code in a project, including p-code based library code. The file also contains some of the C initialization that forms part of the runtime startup code. There is also a single file produced for each assembly source file. Typically, there is at least one assembly file in each project. It contains some of the runtime startup file and is typically named `startup.as`.

## 6.4.1 General Format

The format of the main listing is in the form shown in [Figure 6-1](#).

The line numbers purely relate to the assembly list file and are not associated with the lines numbers in the C or assembly source files. Any assembly that begins with a semi-colon indicates it is a comment added by the code generator. Such comments contain either the original source code, which corresponds to the generated assembly, or is a comment inserted by the code generator to explain some action taken.

Before the output for each function, there is detailed information regarding that function summarized by the code generator. This information relates to register usage, local variable information, functions called, and the calling function.

**FIGURE 6-1: GENERAL FORM OF ASSEMBLY LISTING FILE**

```

768
769
770 0243
771
772 0243 00A3
773
774 0244 3007
775 0245 05A3
776
777 0252 0008
778

;sp2_inpADC.c: 119: void ADC_start(unsigned char chan)
;sp2_inpADC.c: 120: {
  _ADC_start:
; Regs used in _ADC_start: [reg0,reg3]
  movwf  ADC_start@chan
;sp2_inpADC.c: 121: chan &= 0x07;
  movlw  7
  andwf  ADC_start@chan
;_inpADC.c: 128: }
  instruction
; ===== function _ADC_start ends =====

```

**1** line number  
**2** address  
**3** op code  
**4** source comment  
**5** assembly

## 6.4.2 Psect Information

The assembly list file can be used to determine the name of the psect in which a data object or section of code has been placed.

For global symbols, you can check the symbol table in the map file which lists the psect name with each symbol. For symbols local to a module, find the definition of the symbol in the list file. For labels, it is the symbol's name followed by a colon, ':'. Look for the first `PSECT` assembler directive above this code. The name associated with this directive is the psect in which the code is placed, see [Section 6.2.9.3 "PSECT"](#).

## 6.4.3 Function Information

For each C function, printed before the function's assembly label (search for the function's name that is immediately followed by a colon :), is general information relating to the resources used by that function. A typical printout is shown in [Figure 6-2: Function Information](#). Most of the information is self-explanatory, but special comments follow.

The locations shown use the format `offset[space]`. For example, a location of `42[BANK0]` means that the variable was located in the bank 0 memory space and that it appears at an offset of 42 bytes into the compiled stack component in this space, see [Section 5.5.2.2.1 "Compiled Stack Operation"](#).

Whenever pointer variables are shown, they are often accompanied by the targets that the pointer can reference, these targets appear after the arrow `->`. See, also, [Section 6.4.5 "Pointer Reference Graph"](#). The auto and parameter section of this information is especially useful because the size of pointers is dynamic; see [Section 5.4.5 "Pointer Types"](#). This information shows the actual number of bytes assigned to each pointer variable.



The tracked objects are generally not used. It indicates the known state of the currently selected RAM bank on entry to the function and at its exit points. It also indicates the bank selection bits that did, or did not, change in the function.

The hardware stack information shows how many stack levels were taken up by this function alone, and the total levels used by this function and any functions it calls. Note that this is only valid for functions that are have not been inlined.

Functions that use a non-reentrant model are those that allocate auto and parameter variables to a compiled stack and which are, as a result, not reentrant. If a function is marked as being reentrant, it allocates stack-based variables to the software stack and can be reentrantly called.

**FIGURE 6-2: FUNCTION INFORMATION**

```

4064 1 ***** function _render *****
4065 ;; Defined at:
4066 ;;           line 29 in file "draw.c" 2
4067 3 Parameters:  Size Location  Type
4068 ;;           None
4069 ;; Auto vars:  Size Location  Type
4070 ;; lll         4 42[BANK0 ] long
4071 ;; x           2 46[BANK0 ] volatile int
4072 ;; cp         1 41[BANK0 ] PTR unsigned char
4073 ;;           -> inputData(2),
4074 5 Return value: Size Location  Type
4075 ;;           None          void
4076 6 Registers used:
4077 ;;           wreg, fsr0l, fsr0h, status,2, status,0, pclath, cstack
4078 7 Tracked objects:
4079 ;;           On entry : 17F/0
4080 ;;           On exit  : 0/0
4081 ;;           Unchanged: FFE00/0
4082 ;; Data sizes:  COMMON  BANK0  BANK1  BANK2
4083 ;; Params:      0      0      0      0
4084 8 Locals:        0      7      0      0
4085 ;; Temps:       0      5      0      0
4086 ;; Totals:      0     12     0      0
4087 ;; Total ram usage: 12 bytes
4088 ;; Hardware stack levels used: 1
4089 9 Hardware stack levels required when called: 4
4090 ;; This function calls:
4091 ;;           _lrv
4092 ;;           ___altofl
4093 ;;           ___awdiv
4094 ;;           ___awmod
4095 11 This function is called by:
4096 ;;           _main
4097 12 This function uses a non-reentrant model

```

- 1 function's name
- 2 file name and line number of definition
- 3 size, location and type of parameters
- 4 size, location and type of auto variables
- 5 size, location and type of return value
- 6 registers that the function code used
- 7 selected GPR bank on entry and exit
- 8 RAM memory summary for entire function
- 9 hardware stack requirements
- 10 functions called by this function
- 11 which functions call this function
- 12 how the function was encoded

## 6.4.4 Switch Statement Information

Along with the generated code for each `switch` statement is information about how that statement was encoded. There are several strategies the compiler can use for switch statements. The compiler determines the appropriate strategy, see [Section 5.6.3 “Switch Statements”](#), or you can indicate a preference for a particular type of strategy using a pragma, see [Section 5.14.4.10 “The #pragma switch Directive”](#). The information printed will look similar to that shown in [Figure 6-3](#).

**FIGURE 6-3: SWITCH STATEMENT INFORMATION**

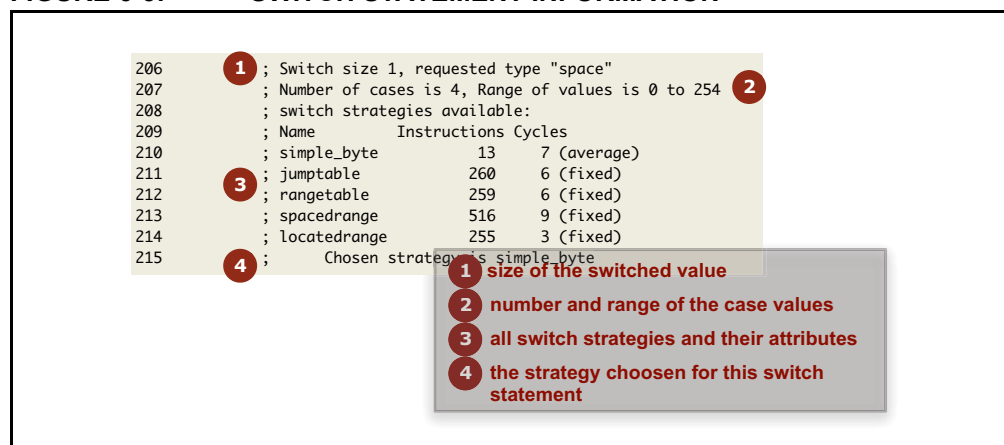

## 6.4.5 Pointer Reference Graph

Other important information contained in the assembly list file is the pointer reference graph (look for *pointer list with targets*: in the list file). This is a list of each pointer contained in the program and each target the pointer can reference through the program. The size and type of each target is indicated, as well as the size and type of the pointer variable itself.

For example, the following shows a pointer called `task_tmr` in the C code. It is local to the function `timer_intr()`. It is also a pointer to an `unsigned int`, and it is one byte wide. There is only one target to this pointer and it is the member `timer_count` in the structure called `task`. This target variable resides in the `BANK0` class and is two bytes wide.

```

timer_intr@task_tmr  PTR unsigned int  size(1); Largest target is 2
                    -> task.timer_count(BANK0[2]),

```

The pointer reference graph shows both pointers to data objects and pointers to functions.

## 6.4.6 Call Graph

The other important information in the assembly list file is the call graph. This is produced for all 8-bit devices, which can use a compiled stack to facilitate stack-based variables (function parameters, `auto` and temporary variables). See [Section 5.5.2.2.1 “Compiled Stack Operation”](#), for more detailed information on compiled stack operation.

Call graph tables, showing call information on a function-by-function basis, are presented in the map file, followed by more traditional call graphs for the entire program. The call graphs are built by the code generator, and are used to allow overlapping of functions' auto-parameter blocks (APBs) in the compiled stack. The call graphs are not used when functions use the software stack (see [Section 5.5.2.2.2 “Software Stack Operation”](#)). You can obtain the following information from studying the call graph.

- The functions in the program that are “root” nodes marking the top of a call tree, and that are called spontaneously
- The functions that the linker deemed were called, or can have been called, during program execution (and those which were called indirectly via a pointer)
- The program's hierarchy of function calls
- The size of the auto and parameter areas within each function's APB
- The offset of each function's APB within the compiled stack
- The estimated call tree depth.

These features are discussed in sections that follow.

## 6.4.6.1 CALL GRAPH TABLES

A typical call graph table can look like the extract shown in [Figure 6-4](#). Look for *Call Graph Tables*: in the list file.

**FIGURE 6-4: CALL GRAPH FORM**

Call Graph Tables:							
(Depth)	Function	Calls	Base Space	Used Autos	Params	Refs	
(0)	_main			12	12	0	34134
			43 BANK0	5	5	0	
		_aOut	0 BANK1	7	7	0	
		_initSPI					
(1)	_aOut			2	0	2	68
		_SPI	2 BANK0	2	0	2	
		_GetDACValue (ARG)					
(1)	_initSPI			0	0	0	0
(2)	_SPI			2	2	0	23
			0 BANK0	2	2	0	
...							
Estimated maximum stack depth 6							

The graph table starts with the function `main()`. Note that the function name will always be shown in the assembly form, thus the function `main()` appears as the symbol `_main`. `main()` is always a root of a call tree. Interrupt functions will form separate trees.

All the functions that `main()` calls, or can call, are shown below the function name in the *Calls* column. So in this example, `main()` calls `aOut()` and `initSPI()`. These have been grouped in the orange box in the figure. If a star (\*) appears next to the function's name, this implies the function has been called indirectly via a pointer. A function's inclusion into the call graph does not imply the function was actually called, but there is a possibility that the function was called. For example, code such as:

```
int test(int a) {
    if(a)
        foo();
    else
        bar();
}
```

will list `foo()` and `bar()` under `test()`, as either can be called. If `a` is always true, then the function `bar()` will never be called, even though it appears in the call graph.

In addition to the called functions, information relating to the memory allocated in the compiled stack for `main()` is shown. This memory will be used for the stack-based variables that are defined in `main()`, as well as a temporary location for the function's return value, if appropriate.

In the orange box for `main()` you can see that it defines 12 `auto` and temporary variable (under the *Autos* column). It defines no parameters – `main()` never has parameters – under the *Params* column. There is a total of 34134 references in the assembly code to local objects in `main()`, shown under the *Refs* column. The *Used* column indicates the total number of bytes of local storage, i.e., the sum of the *Autos* and *Params* columns.

Rather than the compiled stack being one block of memory in one memory space, it can be broken up into multiple blocks placed in different memory spaces to utilize all of the available memory on the target device. This breakdown is shown under the memory summary line for each function. In this example, it shows that 5 bytes of `auto` objects for `main()` are placed in the bank 0 component of the compiled stack (*Space* column), at an offset of 43 (*Base* column) into this stack. It also shows that 7 bytes of `auto` objects were placed in the bank 1 data component of the compiled stack at an offset of 0. The name listed under the *Space* column, is the same name as the linker class which will hold this section of the stack.

Below the information for `main()` (outside the orange box) you will see the same information repeated for the functions that `main()` called, i.e., `aOut()` and `initSPI()`. For clarity, only the first few functions of this program are shown in the figure.

Before the name of each function, and in brackets, is the call stack depth for that particular function. A function can be called from many places in a program, and it can have a different stack depth in the call graph at each call. The maximum call depth is always shown for a function, regardless of its position in the call table. The `main()` function will always have a depth of 0. The starting call depth for interrupt functions assumes a worst case and will start at the start depth of the previous tree plus one.

After each tree in the call graph, there is an indication of the maximum stack depth that might be realized by that tree. This stack depth is not printed if any functions in the graph use the software stack. (In that case, a single stack depth estimate is printed for the entire program at the end of the graphs.) In the example shown, the estimated maximum stack depth is 6. Check the associated data sheet for the depth of your device's hardware stack (see [Section 5.3.4 "Stacks"](#)). The stack depth indicated can be used as a guide to the stack usage of the program. No definitive value can be given for the program's total stack usage for several reasons:

- Certain parts of the call tree may never be reached, reducing that tree's stack usage.
- The exact contribution of interrupt (or other) trees to the `main()` tree cannot be determined as the point in `main()`'s call tree at which the interrupt (or other function invocation) will occur cannot be known. (The compiler assumes the worst case situation of interrupts occurring at the maximum `main()` depth.)
- The assembler optimizer may have replaced function calls with jumps to functions, reducing that tree's stack usage.
- The assembler's procedural abstraction optimizations can have added in calls to abstracted routines, increasing the stack depth. (Checks are made to ensure this does not exceed the maximum stack depth.)
- Functions which are inlined are not called, reducing the stack usage.

The compiler can be configured to manage the hardware stack for PIC10/12/16 devices only, see [Section 4.8.54 "--RUNTIME: Specify Runtime Environment"](#). When this mode is selected, the compiler will convert calls to jumps if it thinks the maximum stack depth of the device is being exceeded. The stack depth estimate listed in the call table will reflect the stack savings made by this feature. Thus, the stack depth and call depth cannot be the same. Note that `main()` is jumped to by the runtime startup, not called; so, `main()` itself does not consume a level of stack. See also [Section 5.10.1 "Runtime Startup Code"](#).

The code generator produces a warning if the maximum stack depth appears to have been exceeded and the stack is not being managed by the compiler. For the above reasons, this warning, too, is intended to be a only a guide to potential stack problems.

## 6.4.6.2 CALL GRAPH CRITICAL PATHS

Immediately prior to the call graph tables in the list file are the critical paths for memory usage identified in the call graphs. A critical path is printed for each memory space and for each call graph. Look for a line similar to *Critical Paths under \_main in BANK0*, which, for this example, indicates the critical path for the `main` function (the root of one call graph) in bank 0 memory. There will be one call graph for the function `main` and another for each interrupt function. Each of these will appear for every memory space the device defines.

A critical path here represents the biggest range of APBs stacked together in a contiguous block. Essentially, it identifies those functions whose APBs are contributing to the program's memory usage in that particular memory space. If you can reduce the memory usage of these functions in the corresponding memory space, then you will affect the program's total memory usage in that memory space.

This information can be presented as follows.

```
3793 ;; Critical Paths under _main in BANK0
3794 ;;
3795 ;;   _main->_foobar
3796 ;;   _foobar->__flsub
3797 ;;   __flsub->__fladd
```

In this example, it shows that of all the call graph paths starting from the function `main`, the path in which `main` calls `foobar`, which calls `flsub`, which calls `fladd`, is using the largest block of memory in bank 0 RAM. The exact memory usage of each function is shown in the call graph tables.

The memory used by functions that are not in the critical path will overlap entirely with that in the critical path. Reducing the memory usage of these will have no impact on the memory usage of the entire program.

## 6.4.6.3 CALL GRAPH GRAPHS

Following the call tables are the call graphs, which show the full call tree for `main()` and any interrupt functions. This is a subset of the information presented in the call tables, and it is shown in a different form. The call graphs will look similar to the one shown in [Figure 6-5](#).

**FIGURE 6-5: CALL GRAPH GRAPHS**

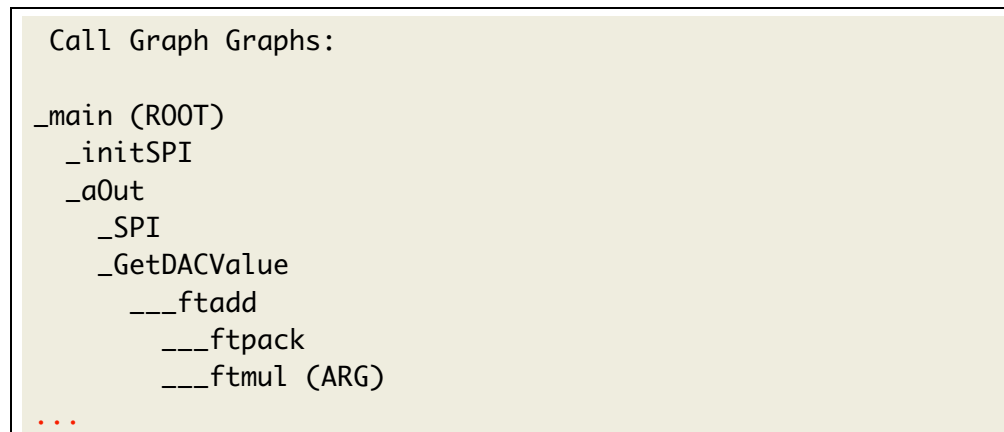

Indentation is used to indicate the call depth. In the diagram, you can see that `main()` calls `aOut()`, which in turn calls `GetDACValue()`, which in turn calls the library function `__ftadd()`, etc. If a star (\*) appears next to the function's name, this implies that the function has been called indirectly via a pointer.

#### 6.4.6.4 ARG NODES

In both the call trees and the call graph itself, you can see functions listed with the annotation (ARG) after its name. This implies that the call to that function at that point in the call graph is made to obtain an argument to another function. For example, in the following code snippet, the function `input()` is called to obtain an argument value to the function `process()`.

```
result = process(input(0x7));
```

For such code, if it were to appear inside the `main()` function, the call graph would contain the following.

```
_main (ROOT)
  _input
  _process
    _input (ARG)
```

This indicates that `main()` calls `input()` and `main()` also calls `process()`, but `input()` is also called as an argument expression to `process()`.

These argument nodes in the graph do *not* contribute to the overall stack depth usage of the program, but they are important for the creation of the compiled stack. The call depth stack usage of the tree indicated above would only be 1, not 2, even though the argument node function is at an indicated depth of 2. This is because there is no actual reentrancy in terms of an actual call and a return address being stored on the hardware stack.

The compiler must ensure that the parameter area for a function and any of its 'argument functions' must be at unique addresses in the compiled stack to avoid data corruption. Note that a function's return value is also stored in its parameter area; so, that needs to be considered by the compiler even if there are no parameters. A function's parameters become 'active' before the function is actually called (when the arguments are passed) and its return value location remains 'active' after the function has returned (while that return value is being processed).

In terms of data allocation, the compiler assumes a function has been 'called' the moment that any of its parameters have been loaded and is still considered 'called' up until its return value is no longer required. Thus, the definition for 'reentrancy' is much broader when considering data allocation than it is when considering stack call depth.

#### 6.4.7 Symbol Table

At the bottom of each assembly list file is a symbol table. This differs from the symbol table presented in the map file (see [Section 7.4.2.6 "Symbol Table"](#)) in two ways:

- It lists only those symbols associated with the assembly module from which the list file is produced (as opposed to the entire program); and
- It lists local as well as global symbols associated with that module.

Each symbol is listed along with the address it has been assigned.

NOTES:



---

---

## Chapter 7. Linker

---

---

### 7.1 INTRODUCTION

This chapter describes the theory behind, and the usage of, the linker.

The application name of the linker is `HLINK`. In most instances it will not be necessary to invoke the linker directly, as the compiler driver, `xc8`, will automatically execute the linker with all the necessary arguments. Using the linker directly is not simple, and should be attempted only by those with a sound knowledge of the compiler, and linking in general. The compiler often makes assumptions about the way in which the program will be linked. If the psects are not linked correctly, code failure can result.

If it is absolutely necessary to use the linker directly, the best way to start is to copy the linker arguments constructed by the compiler driver, and modify them as is appropriate. This ensures that the necessary startup module and arguments are present.

The following topics are examined in this chapter of the MPLAB XC8 C Compiler User's Guide:

- [Operation](#)
- [Relocation and Psects](#)
- [Map Files](#)

### 7.2 OPERATION

A command to the linker takes the following form:

```
hlink [options] files
```

The *options* are zero or more linker options, each of which modifies the behavior of the linker in some way. The *files* is one or more object files, and zero or more object code library names (`.lib` extension).

Note that P-code libraries (`.lpp` extension) are always passed to the code generator application. They cannot be passed to the linker.

The options recognized by the linker are listed in [Table 7-1](#) and discussed in the following paragraphs.

**TABLE 7-1: LINKER COMMAND-LINE OPTIONS**

Option	Effect
-8	use 8086 style segment:offset address form
-Aclass=low-high , . . .	specify address ranges for a class
-Cpsect=class	specify a class name for a global psect
-Cbaseaddr	produce binary output file based at <i>baseaddr</i>
-Dclass=delta	specify a class delta value
-Dsymfile	produce old-style symbol file
-Eerrfile	write error messages to <i>errfile</i>
-F	produce .obj file with only symbol records
-G spec	specify calculation for segment selectors
-H symfile	generate symbol file
-H+ symfile	generate enhanced symbol file
-I	ignore undefined symbols
-J num	set maximum number of errors before aborting
-K	prevent overlaying function parameter and auto areas
-L	preserve relocation items in .obj file
-LM	preserve segment relocation items in .obj file
-N	sort symbol table in map file by address order
-Nc	sort symbol table in map file by class address order
-Ns	sort symbol table in map file by space address order
-Mmapfile	generate a link map in the named file
-Ooutfile	specify name of output file
-Pspec	specify psect addresses and ordering
-Qprocessor	specify the device type (for cosmetic reasons only)
-S	inhibit listing of symbols in symbol file
-Sclass=limit[,bound]	specify address limit, and start boundary for a class of psects
-Usymbol	pre-enter symbol in table as undefined
-Vavmap	use file <i>avmap</i> to generate an <i>Avocet</i> format symbol file
-Wwarnlev	set warning level (-9 to 9)
-Wwidth	set map file width (>=10)
-X	remove any local symbols from the symbol file
-Z	remove trivial local symbols from the symbol file
--DISL=list	specify disabled messages
--EDF=path	specify message file location
--EMAX=number	specify maximum number of errors
--NORLF	do not relocate list file
--VER	print version number and stop

If the standard input is a file, then this file is assumed to contain the command-line argument. Lines can be broken by leaving a *backslash* \ at the end of the preceding line. In this fashion, HLINK commands of almost unlimited length can be issued. For example, a link command file called `x.lnk` and containing the following text:

```
-Z -OX.OBJ -MX.MAP \  
-Ptext=0,data=0/,bss,nvram=bss/. \  
X.OBJ Y.OBJ Z.OBJ
```

can be passed to the linker by one of the following:

```
hlink @x.lnk  
hlink < x.lnk
```

Several linker options require memory addresses or sizes to be specified. The syntax for all of these is similar. By default, the number is interpreted as a decimal value. To force interpretation as a HEX number, a trailing `H`, or `h`, should be added. For example, `765FH` will be treated as a HEX number.

## 7.2.1 -Aclass =low-high,...

`-A` option allows one or more of the address ranges to be assigned a linker class, so that psects can be placed anywhere in this class. Ranges do not need to be contiguous. For example:

```
-ACODE=1020h-7FFEh,8000h-BFFEh
```

specifies that the class called `CODE` represents the two distinct address ranges shown.

Psect can be placed anywhere in these ranges by using the `-P` option and the class name as the address (see [Section 7.2.18 “-Pspec”](#)), for example:

```
-PmyText=CODE
```

Alternatively, any psect that is made part of the `CODE` class, when it is defined (see [Section 6.2.9.3.3 “Class”](#)), will automatically be linked into this range, unless they are explicitly located by another option.

Where there are a number of identical, contiguous address ranges, they can be specified with a repeat count following an `x` character. For example:

```
-ACODE=0-0FFFFh x16
```

specifies that there are 16 contiguous ranges, each 64k bytes in size, starting from address zero. Even though the ranges are contiguous, no psect will straddle a 64k boundary, thus this can result in different psect placement to the case where the option

```
-ACODE=0-0FFFFFFh
```

had been specified, which does not include boundaries on 64k multiples.

The `-A` option does not specify the memory space associated with the address. Once a psect is allocated to a class, the space value of the psect is then assigned to the class, see [Section 6.2.9.3.17 “Space”](#).

## 7.2.2 -Cpsect=class

This option allows a psect to be associated with a specific class. Normally, this is not required on the command line because psect classes are specified in object files. See [Section 6.2.9.3.3 “Class”](#).

## 7.2.3 -Dclass=delta

This option allows the delta value for psects that are members of the specified class to be defined. The delta value should be a number. It represents the number of bytes per addressable unit of objects within the psects. Most psects do not need this option as they are defined with a delta value. See [Section 6.2.9.3.4 “Delta”](#).

## 7.2.4 -Dsymfile

Use this option to produce an old-style symbol file. An old-style symbol file is an ASCII file, where each line has the link address of the symbol followed by the symbol name.

## 7.2.5 -Eerrfile

Error messages from the linker are written to the standard error stream. Under DOS, there is no convenient way to redirect this to a file (the compiler drivers will redirect standard errors, if standard output is redirected). This option makes the linker write all error messages to the specified file instead of the screen, which is the default standard error destination.

## 7.2.6 -F

Normally the linker will produce an object file that contains both program code and data bytes, and symbol information. Sometimes you want to produce a symbol-only object file that can be used again in a subsequent linker run to supply symbol values. The `-F` option suppresses data and code bytes from the output file, leaving only the symbol records.

This option can be used when part of one project (i.e., a separate build) is to be shared with another, as might be the case with a bootloader and application. The files for one project are compiled using this linker option to produce a symbol-only object file. That file is then linked with the files for the other project.

## 7.2.7 -Gspec

When linking programs using segmented, or bank-switched psects, there are two ways the linker can assign segment addresses, or selectors, to each segment. A segment is defined as a contiguous group of psects where each psect in sequence has both its link and load addresses concatenated with the previous psect in the group. The segment address or selector for the segment is the value derived when a segment type relocation is processed by the linker.

By default the segment selector is generated by dividing the base load address of the segment by the relocation quantum of the segment, which is based on the `reloc=` flag value given to psects at the assembler level, see [Section 6.2.9.3.15 "Reloc"](#). The `-G` option allows an alternate method for calculating the segment selector. The argument to `-G` is a string similar to:

$A / 10h - 4h$

where  $A$  represents the load address of the segment and  $/$  represents division. This means "Take the load address of the psect, divide by 10 HEX, then subtract 4". This form can be modified by substituting  $N$  for  $A$ ,  $*$  for  $/$  (to represent multiplication), and adding, rather than subtracting, a constant. The token  $N$  is replaced by the ordinal number of the segment, which is allocated by the linker. For example:

$N * 8 + 4$

means "take the segment number, multiply by 8, then add 4". The result is the segment selector. This particular example would allocate segment selectors in the sequence 4, 12, 20, ... for the number of segments defined.

The selector of each psect is shown in the map file. See [Section 7.4.2.2 "Psect Information Listed by Module"](#).

## 7.2.8 -Hsymfile

This option instructs the linker to generate a symbol file. The optional argument *symfile* specifies the name of the file to receive the data. The default file name is `l.sym`.

**7.2.9 -H+symfile**

This option will instruct the linker to generate an enhanced symbol file, which provides, in addition to the standard symbol file, class names associated with each symbol and a segments section which lists each class name and the range of memory it occupies. This format is recommended if the code is to be run in conjunction with a debugger. The optional argument *symfile* specifies a file to receive the symbol file. The default file name is `l.sym`.

**7.2.10 -I**

Usually, failure to resolve a reference to an undefined symbol is a fatal error. Using this option causes undefined symbols to be treated as warnings, instead.

**7.2.11 -Jerrcount**

The linker will stop processing object files after a certain number of errors (other than warnings). The default number is 10, but the `-J` option allows this to be altered.

**7.2.12 -K**

This option should not be used. It is for older compilers that use a compiled stack. In those cases, the linker tries to overlay function auto and parameter blocks to reduce the total amount of RAM required. For debugging purposes, that feature can be disabled with this option. However, doing so will increase the data memory requirements.

This option has no effect when compiled stack allocation is performed by the code generator. This is the case for OCG (PRO-Standard-Free mode) compilers, and this option should not be used.

**7.2.13 -L**

When the linker produces an output file it does not usually preserve any relocation information, since the file is now absolute. In some circumstances a further "relocation" of the program is done at load time. The `-L` option generates, in the output file, one null relocation record for each relocation record in the input.

**7.2.14 -LM**

Similar to the above option, this preserves relocation records in the output file, but only segment relocations.

**7.2.15 -Mmapfile**

This option causes the linker to generate a link map in the named file, or on the standard output, if the file name is omitted. The format of the map file is illustrated in [Section 7.4 "Map Files"](#).

**7.2.16 -N, -Ns and -Nc**

By default the symbol table in the map file is sorted by name. The `-N` option causes it to be sorted numerically, based on the value of the symbol. The `-Ns` and `-Nc` options work similarly except that the symbols are grouped by either their space value, or class.

**7.2.17 -Ooutfile**

This option allows specification of an output file name for the linker. The default output file name is `l.obj`. Use of this option overrides that default.

## 7.2.18 -Pspec

Psects are linked together and assigned addresses based on information supplied to the linker via `-P` options. The argument to the `-P` option consists of *comma*-separated sequences with the form:

```
-Ppsect=linkaddr+min/loadaddr+min,psect=linkaddr/loadaddr,...
```

All values can be omitted, in which case a default will apply, depending on previous values. The link address of a psect is the address at which it can be accessed at runtime. The load address is the address at which the psect starts within the output file (HEX or binary file etc.), but it is rarely used by 8-bit PIC devices. The addresses specified can be numerical addresses, the names of other psects, classes, or special tokens.

Examples of the basic and most common forms of this option are:

```
-Ptext10=02000h
```

which places (links) the starting address of psect `text10` at address `0x2000`;

```
-PmyData=AUXRAM
```

which places the psect `myData` anywhere in the range of addresses specified by the linker class `AUXRAM` (which would need to be defined using the `-A` option, see [Section 7.2.1 “-Aclass =low-high,...”](#)), and

```
-PstartCode=0200h,endCode
```

which places `endCode` immediately after the end of `startCode`, which will start at address `0x200`.

The additional variants of this option are rarely needed; but, are described below.

If a link or load address cannot be allowed to fall below a minimum value, the *+min*, suffix indicates the minimum address.

If the link address is a negative number, the psect is linked in reverse order with the top of the psect appearing at the specified address minus one. Psects following a negative address will be placed before the first psect in memory.

If the load address is omitted entirely, it defaults to the link address. If the *slash /* character is supplied with no address following, the load address will concatenate with the load address of the previous psect. For example, after processing the option:

```
-Ptext=0,data=0/,bss
```

the `text` psect will have a link and load address of `0`; `data` will have a link address of `0` and a load address following that of `text`. The `bss` psect will concatenate with `data` in terms of both link and load addresses.

A load address specified as a *dot* character, “.” tells the linker to set the load address to be the same as the link address.

The final link and load address of psects are shown in the map file. See [Section 7.4.2.2 “Psect Information Listed by Module”](#).

## 7.2.19 -Qprocessor

This option allows a device type to be specified. This is purely for information placed in the map file. The argument to this option is a string describing the device. There are no behavioral changes attributable to the device type.

## 7.2.20 -S

This option prevents symbol information relating from being included in the symbol file produced by the linker. Segment information is still included.

### 7.2.21 **-Sclass =limit[,bound]**

A class of psects can have an upper address limit associated with it. The following example places a limit on the maximum address of the `CODE` class of psects to one less than 400h.

```
-SCODE=400h
```

Note that to set an upper limit to a psect, this must be set in assembler code using the psect `limit` flag, see [Section 6.2.9.3.8 “Limit”](#)).

If the bound (boundary) argument is used, the class of psects will start on a multiple of the bound address. This example below places the `FARCODE` class of psects at a multiple of 1000h, but with an upper address limit of 6000h.

```
-SFARCODE=6000h,1000h
```

### 7.2.22 **-Usymbol**

This option will enter the specified symbol into the linker’s symbol table as an undefined symbol. This is useful for linking entirely from libraries, or for linking a module from a library where the ordering has been arranged so that by default a later module will be linked.

### 7.2.23 **-Vavmap**

To produce an Avocet format symbol file, the linker needs to be given a map file to allow it to map psect names to Avocet memory identifiers. The `avmap` file will normally be supplied with the compiler, or created automatically by the compiler driver as required.

### 7.2.24 **-Wnum**

The `-w` option can be used to set the warning level, in the range -9 to 9, or the width of the map file, for values of `num`  $\geq 10$ .

`-w9` will suppress all warning messages. `-w0` is the default. Setting the warning level to -9 (`-w-9`) will give the most comprehensive warning messages.

### 7.2.25 **-X**

Local symbols can be suppressed from a symbol file with this option. Global symbols will always appear in the symbol file.

### 7.2.26 **-Z**

Some `local` symbols are compiler generated and not of interest in debugging. This option will suppress from the symbol file all local symbols that have the form of a single alphabetic character, followed by a digit string. The set of letters that can start a trivial symbol is currently “`klfLSu`”. The `-z` option will strip any local symbols starting with one of these letters, and followed by a digit string.

### 7.2.27 **--DISL=message numbers Disable Messages**

This option is mainly used by the command-line driver, `xc8`, to disable particular message numbers. It takes a *comma*-separate list of message numbers that will be disabled during compilation.

This option is applied if compiling using `xc8`, the command-line driver and the `--MSGDISABLE` driver option, see [Section 4.8.40 “--MSGDISABLE: Disable Warning Messages”](#).

See [Section 4.6 “Compiler Messages”](#) for full information about the compiler’s messaging system.

## 7.2.28 --EDF=*message file*: Set Message File Path

This option is mainly used by the command-line driver, `xc8`, to specify the path of the message description file. The default file is located in the `dat` directory in the compiler's installation directory.

See [Section 4.6 "Compiler Messages"](#) for full information about the compiler's messaging system.

## 7.2.29 --EMAX=*number*: Specify Maximum Number of Errors

This option is mainly used by the command-line driver, `xc8`, to specify the maximum number of errors that can be encountered before the assembler terminates. The default number is 10 errors.

This option is applied if compiling using `xc8`, the command-line driver and the `--ERRORS` driver option, see [Section 4.8.29 "--ERRORS: Maximum Number of Errors"](#).

See [Section 4.6 "Compiler Messages"](#) for full information about the compiler's messaging system.

## 7.2.30 --NORLF: Do Not Relocate List File

Use of this option prevents the linker applying fixups to the assembly list file produced by the assembler. This option is normally using by the command line driver, `xc8`, when performing pre-link stages, but is omitted when performing the final link step so that the list file shows the final absolute addresses.

If you are attempting to resolve fixup errors, this option should be disabled so as to fix up the assembly list file and allow absolute addresses to be calculated for this file. If the compiler driver detects the presence of a preprocessor macro `__DEBUG`, which is equated to 1, then this option will be disabled when building. This macro is set when choosing a *Debug* build in MPLAB X IDE. So, always have this option selected if you encounter such errors.

## 7.2.31 --VER: Print Version Number

This option prints information stating the version and build of the linker. The linker will terminate after processing this option, even if other options and files are present on the command line.



---

## 7.3 RELOCATION AND PSECTS

This section looks at the input files that the linker has to work with.

The linker can read both relocatable object files and object-file libraries (`.lib` extension). The library files are a collection of object files packaged into a single unit. So, essentially, we only need consider the format of object files.

Each object file consists of a number of records. Each record has a type that indicates what sort of information it holds. Some record types hold general information about the target device and its configuration, other records types can hold data; and others, program debugging information, for example.

A lot of the information in object files relates to psects. Psects are an assembly domain construct and are essentially a block of something, either instructions or data. Everything that contributes to the program is located in a psect. See [Section 6.2.8 “Program Sections”](#), for an introductory guide. There is a particular record type that is used to hold the data in psects. The bulk of each object file consists of psect records containing the executable code and variables etc.

We are now in a position to look at the fundamental tasks the linker performs, which are:

- combining all the relocatable object files into one
- relocation of psects contained in the object files into memory
- fixup of symbolic references in the psects

There are at least two object files that are passed to the linker. One is produced from all the C code in the project, including C library code. There is only one of these files since the code generator compiles and combines all the C code of the program and produces just the one assembly output. The other file passed to the linker will be the object code produced from the runtime startup code, see [Section 4.4.2 “Startup and Initialization”](#).

If there are assembly source files in the project, then there will also be one object file produced for each source file, and these will be passed to the linker. Existing object files, or object file libraries can also be specified in a project; and if present, these will also be passed to the linker.

The output of the linker is also an object file, but there is only a single file produced. The file is absolute, since relocation will have been performed by the linker. The output file consists of the information from all input object files, merged together.

Relocation consists of placing the psect data into the memory of the target device.

The target device memory specification is passed to the linker by the way of linker options. These options are generated by the command-line driver, `x08`. There are no linker scripts or means of specifying options in any source file. The default linker options rarely need adjusting. But, they can be changed, if required, with caution, using the driver option `-L-`, see [Section 4.8.6 “-L: Adjust Linker Options Directly”](#).

When the psects are placed at actual memory locations, symbolic references made in the psects data can be replaced with absolute values. This is a process called fixup.

For each psect record in the object file, there is a corresponding relocation record that indicates which bytes (or bits) in the psect record need to be adjusted once relocation is complete. The relocation records also specify how the values are to be determined. A linker fixup overflow error can occur if the value determined by the linker is too large to fit in the “hole” reserved for the value in the psect. See [\(477\) fixup overflow in expression \(location 0x\\* \(0x\\*+\\*\), size \\*, value 0x\\*\) \(Linker\)](#) for information on finding the cause of these errors.

## 7.4 MAP FILES

The map file contains information relating to the relocation of psects and the addresses assigned to symbols within those psects.

### 7.4.1 Generation

If compilation is being performed via MPLAB X IDE, a map file is generated by default. If you are using the driver from the command line, use the `-M` option to request that the map file be produced, see [Section 7.2.15 “-Mmapfile”](#). Map files have the extension `.map`.

Map files are produced by the linker. If the compilation process is stopped before the linker is executed, then no map file is produced. The linker produces a map file, even if it encounters errors. The file, then, helps you track down the cause of the errors. However, if the linker ultimately reports `too many errors`, the linker did not run to completion, the map file was not created. You can use the `--ERRORS` option (see [Section 4.8.29 “--ERRORS: Maximum Number of Errors”](#)) on the command line to increase the number of errors encountered before the linker exits.

### 7.4.2 Contents

The sections in the map file, in order of appearance, are as follows.

- the compiler name and version number
- a copy of the command line used to invoke the linker
- the version number of the object code in the first file linked
- the machine type
- a psect summary sorted by the psect's parent object file
- a psect summary sorted by the psect's CLASS
- a segment summary
- unused address ranges summary
- the symbol table
- information summary for each function
- information summary for each module

Portions of an example map file, along with explanatory text, are shown in the following sections.

#### 7.4.2.1 GENERAL INFORMATION

At the top of the map file is general information relating to the execution of the linker. When analyzing a program, always confirm the compiler version number shown in the map file if you have more than one compiler version installed to ensure the desired compiler is being executed.

The device selected with the `--CHIP` option ([Section 4.8.18 “--CHIP: Define Device”](#)), or the one selected in your IDE, should appear after the Machine type entry.

The *object code version* relates to the file format used by relocatable object files produced by the assembler. Unless either the assembler or linker have been updated independently, this should not be of concern.

A typical map file can begin something like the following. This example has been cut down for clarity.

```
--edf=/home/jeff/Microchip/XC8/1.00/dat/en_msgs.txt -cs -h+main.sym -z \
-Q16F946 -o1.obj -Mmain.map -ver=XC8 -ACONST=00h-0FFhx32 \
-ACODE=00h-07FFhx4 -ASTRCODE=00h-01FFFh -AENTRY=00h-0FFhx32 \
-ASTRING=00h-0FFhx32 -ACOMMON=070h-07Fh -ABANK0=020h-06Fh \
-ABANK1=0A0h-0EFh -ABANK2=0120h-016Fh -ABANK3=01A0h-01EFh \
-ARAM=020h-06Fh,0A0h-0EFh,0120h-016Fh,01A0h-01EFh \
-AABS1=020h-07Fh,0A0h-0EFh,0120h-016Fh,01A0h-01EFh -ASFR0=00h-01Fh \
-ASFR1=080h-09Fh -ASFR2=0100h-011Fh -ASFR3=0180h-019Fh \
-preset_vec=00h,intentry,init,end_init -ppowerup=CODE -pfunctab=CODE \
-ACONFIG=02007h-02007h -pconfig=CONFIG -DCONFIG=2 -AIDLOC=02000h-02003h \
-pidloc=IDLOC -DIDLOC=2 -AEEDATA=00h-0FFh/02100h -peeprom_data=EEDATA \
-DEEDATA=2 -DCODE=2 -DSTRCODE=2 -DSTRING=2 -DCONST=2 -DENTRY=2 -k \
startup.obj main.obj
```

Object code version is 3.10

Machine type is 16F946

The *Linker command line* shows all the command-line options and files that were passed to the linker for the last build. Remember, these are linker options, not command-line driver options.

The linker options are necessarily complex. Fortunately, they rarely need adjusting from their default settings. They are formed by the command-line driver, `xc8`, based on the selected target device and the specified driver options. You can often confirm that driver options were valid by looking at the linker options in the map file. For example, if you ask the driver to reserve an area of memory, you should see a change in the linker options used.

If the default linker options must be changed, this can be done indirectly through the driver using the driver `-L-` option, see [Section 4.8.6 “-L-: Adjust Linker Options Directly”](#). If you use this option, always confirm the change appears correctly in the map file.

#### 7.4.2.2 PSECT INFORMATION LISTED BY MODULE

The next section in the map file lists those modules that have made a contribution to the output, and information regarding the psects that these modules have defined. See [Section 5.15.1 “Program Sections”](#) for an introductory explanation of psects.

This section is heralded by the line that contains the headings:

```
Name Link Load Length Selector Space Scale
```

Under this on the far left is a list of object files. These object files include both files generated from source modules and those that were extracted from object library files (`.lib` extension). In the latter case, the name of the library file is printed before the object file list. Note that since the code generator combines all C source files (and p-code libraries), there is only one object file representing the entire C part of the program. The object file corresponding to the runtime startup code is normally present in this list.

The information in this section of the map file can be used to confirm that a module is making a contribution to the output file and to determine the exact psects that each module defines.

Shown are all the psects (under the *Name* column) that were linked into the program from each object file, and information about that psect.

The linker deals with two kinds of addresses: link and load. Generally speaking, the link address of a psect is the address by which it is accessed at runtime.

The load address, which is often the same as the link address, is the address at which the psect starts within the output file (HEX or binary file etc.). If a psect is used to hold bits, the load address is irrelevant and is, instead, used to hold the link address (in bit units) converted into a byte address.

The *Length* of the psect is shown in the units that are used by that psect.

The *Selector* is less commonly used and is of no concern when compiling for PIC devices.

The *Space* field is important as it indicates the memory space in which the psect was placed. For Harvard architecture machines, with separate memory spaces (such as the PIC10/12/16 devices), this field must be used in conjunction with the address to specify an exact storage location. A space of 0 indicates the program memory, and a space of 1 indicates the data memory. See [Section 6.2.9.3.17 "Space"](#).

The *Scale* of a psect indicates the number of address units per byte. This remains blank if the scale is 1, and shows 8 for psects that hold bit objects. The load address of psects that hold bits is used to display the link address converted into units of bytes, rather than the load address. See [Section 6.2.9.3.2 "Bit"](#).

For example, the following appears in a map file.

	Name	Link	Load	Length	Selector	Space	Scale
ext.obj	text	3A	3A	22	30	0	
	bss	4B	4B	10	4B	1	
	rbit	50	A	2	0	1	8

This indicates that one of the files that the linker processed was called `ext.obj`. (This can have been derived from C code or a source file called `ext.as`.)

This object file contained a `text` psect, as well as psects called `bss` and `rbit`.

The psect `text` was linked at address 3A and `bss` at address 4B. At first glance, this seems to be a problem, given that `text` is 22 words long. However, they are in different memory areas, as indicated by the space flag (0 for `text` and 1 for `bss`), and so they do not occupy the same memory.

The psect `rbit` contains bit objects, and this can be confirmed by looking at the scale value, which is 8. Again, at first glance it seems that there could be an issue with `rbit` linked over the top of `bss`. Their space flags are the same, but since `rbit` contains bit objects, its link address is in units of bits. The load address field of `rbit` psect displays the link address converted to byte units, i.e.,  $50h/8 \Rightarrow Ah$ .

Underneath the object file list there can be a label *COMMON*. This shows the contribution to the program from program-wide psects, in particular that used by the compiled stack.

### 7.4.2.3 PSECT INFORMATION LISTED BY CLASS

The next section in the map file shows the same psect information but grouped by the psects' class.

This section is heralded by the line that contains the headings:

```
TOTAL  Name  Link  Load  Length
```

Under this are the class names followed by those psects which belong to this class, see [Section 6.2.9.3.3 "Class"](#). These psects are the same as those listed by module in the above section; there is no new information contained in this section, just a different presentation.

## 7.4.2.4 SEGMENT LISTING

The class listing in the map file is followed by a listing of segments. Typically this section of the map file can be ignored by the user.

A segment is a conceptual grouping of contiguous psects in the same memory space, and is used by the linker as an aid in psect placement. There is no segment assembler directive and segments cannot be controlled in any way.

This section is heralded by the line that contains the headings:

```
SEGMENTS  Name  Load  Length  Top  Selector  Space  Class
```

The name of a segment is derived from the psect in the contiguous group with the lowest link address. This can lead to confusion with the psect with the same name. Do not read psect information from this section of the map file.

Again, this section of the map file can be ignored.

## 7.4.2.5 UNUSED ADDRESS RANGES

The last of the memory summaries show the memory that has not been allocated, and is unused. The linker is aware of any memory allocated by the code generator (for absolute variables), and so this free space is accurate.

This section follows the heading:

```
UNUSED ADDRESS RANGES
```

and is followed by a list of classes and the memory that is still available in each class. If there is more than one memory range available in a class, each range is printed on a separate line. Any paging boundaries located within a class are not displayed. But, the column *Largest block* shows the largest contiguous free space (which takes into account any paging in the memory range). If you are looking to see why psects cannot be placed into memory (e.g., cant-find-space type errors) then this is important information to study.

Note that the memory associated with a class can overlap that in others, thus the total free space is not simply the addition of all the unused ranges.

## 7.4.2.6 SYMBOL TABLE

The next section in the map file alphabetically lists the global symbols that the program defines. This section has the heading:

Symbol Table

As always with the linker, any C-derived symbol is shown with its assembler-equivalent symbol name. See [Section 5.12.3 “Interaction between Assembly and C Code”](#).

The symbols listed in this table are:

- Global assembly labels
- Global EQU /SET assembler directive labels
- Linker-defined symbols

Assembly symbols are made global via the GLOBAL assembler directive, see [Section 6.2.9.1 “GLOBAL”](#) for more information.

Linker-defined symbols act like EQU directives. However, they are defined by the linker during the link process, and no definition for them appears in any source or intermediate file. See [Section 5.15.7 “Linker-Defined Symbols”](#).

Each symbol is shown with the psect in which it is defined, and the value (usually an address) it has been assigned. There is not any information encoded into a symbol to indicate whether it represents code or data – nor in which memory space it resides.

If the psect of a symbol is shown as (abs), this implies that the symbol is not directly associated with a psect. Such is the case for absolute C variables, or any symbols that are defined using an EQU directive in assembly.

Note that a symbol table is also shown in each assembler list file. (See [Section 4.8.15 “--ADDRQUAL: Set Compiler Response to Memory Qualifiers”](#) for information on generating these files.) These differ to that shown in the map file as they also list local symbols, and they only show symbols defined in the corresponding module.

## 7.4.2.7 FUNCTION INFORMATION

Following the symbol table is information relating to each function in the program. This information is identical to the function information displayed in the assembly list file. However, the information from all functions is collated in the one location. See [Section 6.4.3 “Function Information”](#) for detailed descriptions of this information.

## 7.4.2.8 MODULE INFORMATION

The final section in the map file shows code usage summaries for each module. Each module in the program will show information similar to the following.

Module	Function	Class	Link	Load	Size
main.c					
	init	CODE	07D8	0000	1
	main	CODE	07E5	0000	13
	getInput	CODE	07D9	0000	4

main.c estimated size: 18

The module name is listed (main.c in the above example). The special module name shared is used for data objects allocated to program memory and to code that is not specific to any particular module.

Next, the user-defined and library functions defined by each module are listed along with the class in which that psect is located (see [Section 5.15.3 “Default Linker Classes”](#)), the psect’s link and load address, and its size (shown as bytes for PIC18 devices and words for other 8-bit devices).

After the function list is an estimated size of the program memory used by that module.

## **Chapter 8. Utilities**

---

---

### **8.1 INTRODUCTION**

This chapter discusses some of the utility applications that are bundled with the compiler.

The applications discussed in this chapter are those more commonly used, but you do not typically need to execute them directly. Most of their features are invoked indirectly by the command line driver that is based on the command-line arguments or MPLAB X IDE project property selections.

The following applications are described in this chapter of the MPLAB XC8 C Compiler User's Guide:

- [Librarian](#)
- [HEXMATE](#)
- [Hash Functions](#)

## 8.2 LIBRARIAN

The librarian program, `LIBR`, has the function of combining several files into a single file known as a library. The reasons you might want to use a library in a project are:

- there will be fewer files to link
- the file content will be accessed faster
- libraries uses less disk space

The librarian can build p-code libraries (`.lpp` extension) from p-code files (`.p1` extension), or object code libraries (`.lib` extension) from object files (`.obj` extension). P-code libraries should be only created if all the library source code is written in C. Object code libraries should be used for assembly code that is to be built into a library.

With both library types, only those modules required by a program will be extracted and included in the program output.

### 8.2.1 The Library Format

The modules in a library are simply concatenated, but a directory of the modules and symbols in the library is maintained at the beginning of a library file. Since this directory is smaller than the sum of the modules, on the first pass the linker can perform faster searches by just reading the directory, and not all the modules. On the second pass, it needs to read only those modules which are required, seeking them over the others. This all minimizes disk I/O when linking.

It should be noted that the library format is not a general purpose archiving mechanism as is used by some other compiler systems. This has the advantage that the format can be optimized toward speeding up the linkage process.

### 8.2.2 Using the Librarian

Library files can be built directly using the command-line driver; see [Section 4.8.47 “--OUTPUT= type: Specify Output File Type”](#). In this case, the driver will invoke `LIBR` with the appropriate options saving you from having to use the librarian directly. You might wish to perform this step manually, or you might need to look at the contents of library files, for example. This section shows how the librarian can be executed from the command-line. The librarian cannot be called from IDEs, such as MPLAB X IDE.

The librarian program is called `LIBR`, and the formats of commands to it are as follows:

```
LIBR [options] k file.lpp [file1.p1 file2.p1...]
LIBR [options] k file.lib [file1.obj file2.obj ...]
```

*options* is zero or more librarian options that affect the output of the program. These are listed in [Table 8-1](#).

**TABLE 8-1: LIBRARIAN COMMAND-LINE OPTIONS**

Option	Effect
<code>-P width</code>	Specify page width
<code>-W</code>	Suppress non-fatal errors

A key letter, *k*, denotes the command requested of the librarian (replacing, extracting, or deleting modules, listing modules or symbols). These commands are listed in [Table 8-2](#).



TABLE 8-2: LIBRARIAN KEY LETTER COMMANDS

Key	Meaning
r	Replace modules
d	Delete modules
x	Extract modules
m	List modules
s	List modules with symbols
o	Re-order modules

The first file name listed after the key is the name of the library file to be used. The following files, if required, are the modules of the library that is required by the command specified.

If you are building a p-code library, the modules listed must be p-code files. If you are building an object file library, the modules listed must be object files.

When replacing or extracting modules, the names of the modules to be replaced or extracted must be specified. If no names are supplied, all the modules in the library will be replaced or extracted respectively.

Adding a file to a library is performed by requesting the librarian to replace it in the library. Since it is not present, the module will be appended to the library. If the `r` key is used and the library does not exist, it will be created.

When using the `d` key letter, the named modules will be deleted from the library. In this instance, it is an error not to give any module names.

The `m` and `s` key letters will list the named modules and, in the case of the `s` key letter, the global symbols defined or referenced within. A `D` or `U` letter is used to indicate whether each symbol is defined in the module, or referenced but undefined. As with the `r` and `x` key letters, an empty list of modules means all the modules in the library.

The `o` key takes a list of module names and re-orders the matching modules in the library file so that they have the same order as the one listed on the command line. Modules that are not listed are left in their existing order, and will appear after the re-ordered modules.

### 8.2.2.1 EXAMPLES

Here are some examples of usage of the librarian. The following command:

```
LIBR s pic-stdlib-d24.lpp ctime.p1
```

lists the global symbols in the modules `ctime.p1`, as shown here:

```
ctime.p1                D _moninit
                        D _localtime
                        D _gmtime
                        D _asctime
                        D _ctime
```

The `D` letter before each symbol indicates that these symbols are defined by the module.

Using the command above without specifying the module name will list all the symbols defined (or undefined) in the library.

The following command deletes the object modules `a.obj`, `b.obj` and `c.obj` from the library `lcd.lib`:

```
LIBR d lcd.lib a.obj b.obj c.obj
```

## 8.2.3 Supplying Arguments

Since it is often necessary to supply many object file arguments to `LIBR`, arguments will be read from standard input if no command-line arguments are given. If the standard input is attached to the console, `LIBR` will prompt for input.

Multiple line input can be given by using a *backslash* as a continuation character on the end of a line. If standard input is redirected from a file, `LIBR` will take input from the file, without prompting. For example:

```
libr
libr> r file.lib 1.obj 2.obj 3.obj \
libr> 4.obj 5.obj 6.obj
```

will perform much the same as if the object files had been typed on the command line. The `libr>` prompts were printed by `LIBR` itself, the remainder of the text was typed as input.

```
libr <lib.cmd
```

`LIBR` will read input from `lib.cmd`, and execute the command found therein. This allows a virtually unlimited length command to be given to `LIBR`.

## 8.2.4 Ordering of Libraries

The librarian creates libraries with the modules in the order in which they were given on the command line. When updating a library the order of the modules is preserved. Any new modules added to a library after it has been created will be appended to the end.

The ordering of the modules in a library is significant to the linker. If a library contains a module that references a symbol defined in another module in the same library, the module defining the symbol should come after the module referencing the symbol.

## 8.2.5 Error Messages

`LIBR` issues various error messages, most of which represent a fatal error. However, some of those messages represent harmless occurrences, which will, nonetheless, be reported. That is, unless the `-w` option was used. In that case, all warning messages are suppressed.

## 8.3 HEXMATE

The `HEXMATE` utility is a program designed to manipulate Intel HEX files. `HEXMATE` is a post-link stage utility that is automatically invoked by the compiler driver, and that provides the facility to:

- Calculate and store variable-length hash values
- Fill unused memory locations with known data sequences
- Merge multiple Intel HEX files into one output file
- Convert `INHX32` files to other `INHX` formats (e.g., `INHX8M`)
- Detect specific or partial opcode sequences within a HEX file
- Find/replace specific or partial opcode sequences
- Provide a map of addresses used in a HEX file
- Change or fix the length of data records in a HEX file
- Validate checksums within Intel HEX files.

Typical applications for `HEXMATE` might include:

- Merging a bootloader or debug module into a main application at build time
- Calculating a checksum or CRC value over a range of program memory and storing its value in program memory or EEPROM
- Filling unused memory locations with an instruction to send the PC to a known location if it gets lost
- Storage of a serial number at a fixed address
- Storage of a string (e.g., time stamp) at a fixed address
- Store initial values at a particular memory address (e.g., initialize EEPROM)
- Detecting usage of a buggy/restricted instruction
- Adjusting HEX file to meet requirements of particular bootloaders

### 8.3.1 `HEXMATE` Command Line Options

`HEXMATE` is automatically called by the command line driver, `xc8`. This is primarily to merge HEX files in with the output generated by the source files. However, there are some `xc8` options which map directly to `HEXMATE` options. So, other functionality can be requested without running `HEXMATE` on the command line explicitly. For other functionality, the following sections detail the options that are available when running this application.

If `HEXMATE` is to be run directly, its usage is:

```
HEXMATE [specs,]file1.HEX [[specs,]file2.HEX ...  
[specs,]fileN.HEX] [options]
```

where `file1.HEX` through to `fileN.HEX` form a list of input Intel HEX files to merge using `HEXMATE`.

If only one HEX file is specified, no merging takes place, but other functionality is specified by additional options. Table 8-3 lists the command line options that HEXMATE accepts.

**TABLE 8-3:** HEXMATE COMMAND-LINE OPTIONS

Option	Effect
-ADDRESSING	Set address fields in all HEXMATE options to use word addressing or other
-BREAK	Break continuous data so that a new record begins at a set address.
-CK	Calculate and store a value.
-FILL	Program unused locations with a known value.
-FIND	Search and notify if a particular code sequence is detected.
-FIND . . . , DELETE	Remove the code sequence if it is detected (use with caution).
-FIND . . . , REPLACE	Replace the code sequence with a new code sequence.
-FORMAT	Specify maximum data record length or select INHX variant.
-HELP	Show all options or display help message for specific option.
-LOGFILE	Save HEXMATE analysis of output and various results to a file.
-MASK	Logically AND a memory range with a bitmask
-Ofile	Specify the name of the output file.
-SERIAL	Store a serial number or code sequence at a fixed address.
-SIZE	Report the number of bytes of data contained in the resultant HEX image.
-STRING	Store an ASCII string at a fixed address.
-STRPACK	Store an ASCII string at a fixed address using string packing.
-W	Adjust warning sensitivity.
+	Prefix to any option to overwrite other data in its address range, if necessary.

If you are using the driver, `xc8`, to compile your project (or the IDE), a log file is produced by default. It will have the project's name and the extension `.hxl`.

The input parameters to HEXMATE are now discussed in detail. Note that any integral values supplied to the HEXMATE options should be entered as hexadecimal values without leading `0x` or trailing `h` characters. Note also, that any address fields specified in these options are to be entered as byte addresses, unless specified otherwise in the `-ADDRESSING` option.

### 8.3.1.1 SPECIFICATIONS,FILENAME.HEX

HEXMATE can process Intel HEX files that use either INHX32 or INHX8M format. Additional specifications can be applied to each HEX file to place restrictions or conditions on how this file should be processed.

If any specifications are used, they must precede the filename. The list of specifications will then be separated from the filename by a *comma*.

A *range restriction* can be applied with the specification *rStart-End*, where *Start* and *End* are both assumed to be hexadecimal values. A range restriction will cause only the address data falling within this range to be used. For example:

```
r100-1FF,myfile.hex
```

will use *myfile.hex* as input, but only process data which is addressed within the range 100h-1FFh (inclusive) from that file.

An address shift can be applied with the specification *sOffset*. If an address shift is used, data read from this HEX file will be shifted (by the offset specified) to a new address when generating the output. The offset can be either positive or negative. For example:

```
r100-1FFs2000,myfile.HEX
```

will shift the block of data from 100h-1FFh to the new address range 2100h-21FFh.

Be careful when shifting sections of executable code. Program code should only be shifted if it is position independent.

### 8.3.1.2 + PREFIX

When the + operator precedes an argument or input file, the data obtained from that source will be forced into the output file and will overwrite another other data existing at that address range. For example:

```
+input.HEX +-STRING@1000="My string"
```

Ordinarily, HEXMATE will issue an error if two sources try to store differing data at the same location. Using the + operator informs HEXMATE that if more than one data source tries to store data to the same address, the one specified with a + prefix will take priority.

### 8.3.1.3 -ADDRESSING

By default, all address arguments in HEXMATE options expect that values will be entered as byte addresses. In some device architectures, the native addressing format can be something other than byte addressing. In these cases, it would be much simpler to be able to enter address-components in the device's native format. To facilitate this, the -ADDRESSING option is used.

This option takes one parameter that configures the number of bytes contained per address location. If, for example, a device's program memory naturally used a 16-bit (2 byte) word-addressing format, the option -ADDRESSING=2 will configure HEXMATE to interpret all command line address fields as word addresses. The affect of this setting is global and all HEXMATE options will now interpret addresses according to this setting. This option will allow specification of addressing modes from one byte per address to four bytes per address.

### 8.3.1.4 -BREAK

This option takes a *comma*-separated list of addresses. If any of these addresses are encountered in the HEX file, the current data record will conclude and a new data record will recommence from the nominated address. This can be useful to use new data records to force a distinction between functionally different areas of program space. Some HEX file readers depend on this.

## 8.3.1.5 -CK

The -CK option is for calculating a hash value. The usage of this option is:

```
-CK=start-end@destination [+offset] [wWidth] [tCode] [gAlgorithm] [pPolynomial]
```

where:

- *start* and *end* specify the address range over which the hash will be calculated.
- *destination* is the address where the hash result will be stored. This value cannot be within the range of calculation.
- *offset* is an optional initial value to be used in the calculations.
- *Width* is optional and specifies the byte-width of the result. Results can be calculated for byte-widths of 1 to 4 bytes. If a positive width is requested, the result will be stored in big-endian byte order. A negative width will cause the result to be stored in little-endian byte order. If the width is left unspecified, the result will be 2 bytes wide and stored in little-endian byte order. This width argument is not used if you have selected any Fletcher algorithm.
- *Code* is a hexadecimal code that will trail each byte in the result. This can allow each byte of the hash result to be embedded within an instruction.
- *Algorithm* is an integer to select which HEXMATE hash algorithm to use to calculate the result. A list of selectable algorithms is provided in [Table 8-4](#). If unspecified, the default algorithm used is 8-bit checksum addition (1).
- *Polynomial* is a hexadecimal value which is the polynomial to be used if you have selected a CRC algorithm.

All numerical arguments are assumed to be hexadecimal values, except for the algorithm selector and result width, which are assumed to be decimal values.

A typical example of the use of the checksum option is:

```
-CK=0-1FFF@2FFE+2100w2g2
```

This will calculate a checksum over the range 0 to 0x1FFF and program the checksum result at address 0x2FFE. The checksum value will be offset by 0x2100. The result will be two bytes wide.

**TABLE 8-4: HEXMATE HASH ALGORITHM SELECTION**

Selector	Algorithm Description
-5	Reflected cyclic redundancy check (CRC)
-4	Subtraction of 32 bit values from initial value
-3	Subtraction of 24 bit values from initial value
-2	Subtraction of 16 bit values from initial value
-1	Subtraction of 8 bit values from initial value
1	Addition of 8 bit values from initial value
2	Addition of 16 bit values from initial value
3	Addition of 24 bit values from initial value
4	Addition of 32 bit values from initial value
5	Cyclic redundancy check (CRC)
7	Fletcher's checksum (8 bit calculation, 2-byte result width)
8	Fletcher's checksum (16 bit calculation, 4-byte result width)

For more details about the algorithms that are used to calculate checksums, see [Section 8.4 "Hash Functions"](#).

## 8.3.1.6 -FILL

The `-FILL` option is used for filling unused memory locations with a known value. The usage of this option is:

```
-FILL=[const_width:]fill_expr[@address[:end_address]]
```

where:

- *const\_width* has the form *wn* and signifies the width (*n* bytes) of each constant in *fill\_expr*. If *const\_width* is not specified, the default value is the native width of the architecture. That is, `-FILL=w1:1` will fill every byte with the value `0x01`.
- *fill\_expr* can use the syntax (where *const* and *increment* are *n*-byte constants):
  - *const* fill memory with a repeating constant; i.e., `-FILL=0xBEEF` becomes `0xBEEF, 0xBEEF, 0xBEEF, 0xBEEF`
  - *const+=increment* fill memory with an incrementing constant; i.e., `-FILL=0xBEEF+=1` becomes `0xBEEF, 0xBEF0, 0xBEF1, 0xBEF2`
  - *const-=increment* fill memory with a decrementing constant; i.e., `-FILL=0xBEEF-=0x10` becomes `0xBEEF, 0xBEDF, 0xBECF, 0xBEBF`
  - *const, const, ..., const* fill memory with a list of repeating constants; i.e., `-FILL=0xDEAD, 0xBEEF` becomes `0xDEAD, 0xBEEF, 0xDEAD, 0xBEEF`
- The options following *fill\_expr* result in the following behavior:
  - *@address* fill a specific address with *fill\_expr*; i.e., `-FILL=0xBEEF@0x1000` puts `0xBEEF` at address `1000h`
  - *@address:end\_address* fill a range of memory with *fill\_expr*; i.e., `-FILL=0xBEEF@0:0xFF` puts `0xBEEF` in unused addresses between `0` and `255`

All constants can be expressed in (unsigned) binary, octal, decimal or hexadecimal, as per normal C syntax, for example, `1234` is a decimal value, `0xFF00` is hexadecimal and `FF00` is illegal.

## 8.3.1.7 -FIND

This option is used to detect and log occurrences of an opcode or partial code sequence. The usage of this option is:

```
-FIND=Findcode [mMask]@Start-End [/Align] [w] [t"Title"]
```

where:

- *Findcode* is the hexadecimal code sequence to search for and is entered in little endian byte order.
- *Mask* is optional. It specifies a bit mask applied over the *Findcode* value to allow a less restrictive search. It is entered in little endian byte order.
- *Start* and *End* limit the address range to search.
- *Align* is optional. It specifies that a code sequence can only match if it begins on an address that is a multiple of this value.
- *w*, if present, will cause HEXMATE to issue a warning whenever the code sequence is detected.
- *Title* is optional. It allows a title to be given to this code sequence. Defining a title will make log-reports and messages more descriptive and more readable. A title will not affect the actual search results.

All numerical arguments are assumed to be hexadecimal values.

Here are some examples.

The option `-FIND=3412@0-7FFF/2w` will detect the code sequence `1234h` when aligned on a 2 (two) byte address boundary, between `0h` and `7FFFh`. *w* indicates that a warning will be issued each time this sequence is found.

In this next example, `-FIND=3412M0F00@0-7FFF/2wt"ADDXY"`, the option is the same as in last example but the code sequence being matched is masked with `000Fh`, so HEXMATE will search for any of the opcodes `123xh`, where *x* is any digit. If a byte-mask is used, it must be of equal byte-width to the opcode it is applied to. Any messaging or reports generated by HEXMATE will refer to this opcode by the name, `ADDXY`, as this was the title defined for this search.

If HEXMATE is generating a log file, it will contain the results of all searches. `-FIND` accepts whole bytes of HEX data from 1 to 8 bytes in length. Optionally, `-FIND` can be used in conjunction with `REPLACE` or `DELETE` (as described below).

## 8.3.1.8 -FIND...,DELETE

If the `DELETE` form of the `-FIND` option is used, any matching sequences will be removed. This function should be used with extreme caution and is not normally recommended for removal of executable code.

## 8.3.1.9 -FIND...,REPLACE

If the `REPLACE` form of the `-FIND` option is used, any matching sequences will be replaced, or partially replaced, with new codes. The usage for this sub-option is:

```
-FIND...,REPLACE=Code [mMask]
```

where:

- *Code* is a little endian hexadecimal code to replace the sequences that match the `-FIND` criteria.
- *Mask* is an optional bit mask to specify which bits within *Code* will replace the code sequence that has been matched. This can be useful if, for example, it is only necessary to modify 4 bits within a 16-bit instruction. The remaining 12 bits can be masked and left unchanged.



## 8.3.1.10 -FORMAT

The `-FORMAT` option can be used to specify a particular variant of INHX format or adjust maximum record length. The usage of this option is:

```
-FORMAT=Type [, Length]
```

where:

- *Type* specifies a particular INHX format to generate.
- *Length* is optional and sets the maximum number of bytes per data record. A valid length is between 1 and 16 decimal, with 16 being the default.

Consider the case of a bootloader trying to download an INHX32 file, which fails because it cannot process the extended address records that are part of the INHX32 standard. You know that this bootloader can only program data addressed within the range 0 to 64k, and that any data in the HEX file outside of this range can be safely disregarded. In this case, by generating the HEX file in INHX8M format the operation might succeed. The `HEXMATE` option to do this would be `-FORMAT=INHX8M`.

Now, consider if the same bootloader also required every data record to contain exactly 8 bytes of data. This is possible by combining the `-FORMAT` with `-FILL` options. Appropriate use of `-FILL` can ensure that there are no gaps in the data for the address range being programmed. This will satisfy the minimum data length requirement. To set the maximum length of data records to 8 bytes, just modify the previous option to become `-FORMAT=INHX8M, 8`.

The possible types that are supported by this option are listed in [Table 8-5](#). Note that INHX032 is not an actual INHX format. Selection of this type generates an INHX32 file, but will also initialize the upper address information to zero. This is a requirement of some device programmers.

**TABLE 8-5: INHX TYPES USED IN -FORMAT OPTION**

Type	Description
INHX8M	cannot program addresses beyond 64K
INHX32	can program addresses beyond 64K with extended linear address records
INHX032	INHX32 with initialization of upper address to zero

## 8.3.1.11 -HELP

Using `-HELP` will list all `HEXMATE` options. Entering another `HEXMATE` option as a parameter of `-HELP` will show a detailed help message for the given option. For example:

```
-HELP=string
```

will show additional help for the `-STRING HEXMATE` option.

## 8.3.1.12 -LOGFILE

The `-LOGFILE` option saves HEX file statistics to the named file. For example:

```
-LOGFILE=output.hxl
```

will analyze the HEX file that `HEXMATE` is generating, and save a report to a file named `output.hxl`.

## 8.3.1.13 -MASK

Use this option to logically AND a memory range with a particular bitmask. This is used to ensure that the unimplemented bits in program words (if any) are left blank. The usage of this option is as follows:

```
-MASK=hexcode@start-end
```

where *hexcode* is a value that will be ANDed with data within the *start* to *end* address range. All values are assumed to be hexadecimal. Multibyte mask values can be entered in little endian byte order.

## 8.3.1.14 -OFILE

The generated Intel HEX output will be created in this file. For example:

```
-Oprogram.hex
```

will save the resultant output to `program.hex`. The output file can take the same name as one of its input files; but, by doing so, it will replace the input file entirely.

## 8.3.1.15 -SERIAL

This option will store a particular HEX value at a fixed address. The usage of this option is:

```
-SERIAL=Code [+/-Increment]@Address [+/-Interval] [rRepetitions]
```

where:

- *Code* is a hexadecimal value to store and is entered in little-endian byte order.
- *Increment* is optional and allows the value of *Code* to change by this value with each repetition (if requested).
- *Address* is the location to store this code, or the first repetition thereof.
- *Interval* is optional and specifies the address shift per repetition of this code.
- *Repetitions* is optional and specifies the number of times to repeat this code.

All numerical arguments are assumed to be hexadecimal values, except for the *Repetitions* argument, which is assumed to be a decimal value.

For example:

```
-SERIAL=000001@EFFF
```

will store HEX code `00001h` to address `EFFEh`.

Another example:

```
-SERIAL=0000+2@1000+10r5
```

will store 5 codes, beginning with value `0000` at address `1000h`. Subsequent codes will appear at address intervals of `+10h` and the code value will change in increments of `+2h`.

## 8.3.1.16 -SIZE

Using the `-SIZE` option will report the number of bytes of data within the resultant HEX image to standard output. The size will also be recorded in the log file if one has been requested.

### 8.3.1.17 -STRING

The `-STRING` option will embed an ASCII string at a fixed address. The usage of this option is:

```
-STRING@Address [tCode]="Text"
```

where:

- *Address* is assumed to be a hexadecimal value representing the address at which the string will be stored.
- *Code* is optional and allows a byte sequence to trail each byte in the string. This can allow the bytes of the string to be encoded within an instruction.
- *Text* is the string to convert to ASCII and embed.

For example:

```
-STRING@1000="My favorite string"
```

will store the ASCII data for the string, `My favorite string` (including the null character terminator), at address `1000h`.

And again:

```
-STRING@1000t34="My favorite string"
```

will store the same string, trailing every byte in the string with the HEX code `34h`.

### 8.3.1.18 -STRPACK

This option performs the same function as `-STRING`, but with two important differences. First, only the lower seven bits from each character are stored. Pairs of 7-bit characters are then concatenated and stored as a 14-bit word rather than in separate bytes. This is known as string packing. This is usually only useful for devices where program space is addressed as 14-bit words (PIC10/12/16 devices). The second difference is that `-STRING`'s `t` specifier is not applicable with the `-STRPACK` option.

## 8.4 HASH FUNCTIONS

A hash value is a small fixed-size value that is calculated from, and used to represent, all the values in an arbitrary-sized block of data. If that data block is copied, a hash recalculated from the new block can be compared to the original hash. Agreement between the two hashes provides a high level of certainty that the copy is valid. There are many hash algorithms. More complex algorithms provide a more robust verification, but could use too many resources when used in an embedded environment.

HEXMATE can be used to calculate the hash of a program image that is contained in a HEX file built by the MPLAB XC8 compiler. This hash can be embedded into that HEX file and burned into the target device along with the program image. At runtime, the target device might be able to run a similar hash algorithm over the program image, now stored in its memory. If the stored and calculated hashes are the same, the embedded program can assume that it has a valid program image to execute.

HEXMATE implements several checksum and cyclic redundancy check algorithms to calculate the hash. If you are using the XC8 C Compiler driver or MPLAB X IDE to perform project builds, the driver's `--CHECKSUM` option (see [Section 4.8.17 "--CHECKSUM: Calculate a Checksum"](#)) will instruct the driver to invoke HEXMATE and pass it the appropriate HEXMATE options. If you are driving HEXMATE explicitly, the option to select the algorithm is described in [Section 8.3.1.5 "-CK"](#). In the discussion of the algorithms below, it is assumed you are using the compiler driver to request a checksum or CRC.

Some consideration is required when program images contain unused memory locations. The driver's `--CHECKSUM` option automatically requests that HEXMATE fill unused memory locations to match unprogrammed device memory. You might need to mimic this action if invoking HEXMATE explicitly.

Although HEXMATE will work with any PIC device, not all devices can read the entire width of their program memory. Thus some devices cannot calculate a hash at runtime from memory containing instructions, and the code examples in the following sections are not usable with all devices.

The following sections provide examples of the algorithms that can be used to calculate the hash at runtime.

### 8.4.1 Addition Algorithms

HEXMATE has several simple checksum algorithms that sum data values over a range in the program image. These algorithms correspond to the selector values 1, 2, 3, and 4 in the `algorithm` suboption and read the data in the program image as 1, 2, 3 or 4 byte quantities, respectively. This summation is added to an initial value (offset) that is supplied to the algorithm via the same option. The width to which the final checksum is truncated is also specified by this option and can be 1, 2, 3, or 4 bytes. HEXMATE will automatically store the checksum in the HEX file at the address specified in the `checksum` option.

The function shown below can be customized to work with any combination of data size (`readType`) and checksum width (`resultType`).

```
typedef unsigned char readType; // size of data values read and summed
typedef unsigned int  resultType; // size of checksum result

// add to offset n additions of values starting at address data,
// truncating and returning the result
// data: the address of the first value to sum
// n:    the number of sums to perform
// offset: the initial value to which the sum is added
resultType ck_add(const readType *data, unsigned n, resultType offset)
{
    resultType chksum;

    chksum = offset;
    while(n--) {
        chksum += *data;
        data++;
    }
    return chksum;
}
```

The `readType` and `resultType` type definitions should be adjusted to suit the data read/sum width and checksum result width, respectively. When using MPLAB XC8 and for a size of 1, use a `char` type; for a size of 3, use a `short long` type, etc., or consider using the exact-width types provided by `<stdint.h>`. If you never use an offset, that parameter can be removed and `chksum` assigned 0 before the loop.

Here is how this function might be used when, for example, a 2-byte-wide checksum is to be calculated from the addition of 1-byte-wide values over the address range 0x100 to 0x7fd, starting with an offset of 0x20. The checksum is to be stored at 0x7fe and 0x7ff in little endian format. The following option is specified when building the project. (In MPLAB X IDE, only enter the information to the right of the first = in the Checksum field in the Additional options Option category in the XC8 Linker category.)

```
--CHECKSUM=100-7fd@7fe,offset=20,algorithm=1,width=-2
```

Into your project, add the following code snippet, which calls `ck_add`, above, and compare the runtime checksum with that stored by HEXMATE at compile time.

```
extern const readType ck_range[0x6fe/sizeof(readType)] @ 0x100;
extern const resultType hexmate @ 0x7fe;
resultType result;

result = ck_add(ck_range, sizeof(ck_range)/sizeof(readType), 0x20);
if(result != hexmate)
    ck_failure(); // take appropriate action
```

This code uses the placeholder array, `ck_range`, to represent the memory over which the checksum is calculated, and the variable `hexmate` is mapped over the locations where HEXMATE will have stored its checksum result. Being `extern` and absolute, neither of these objects consume additional device memory. Adjust the addresses and sizes of these objects to match the option you pass to HEXMATE.

HEXMATE can calculate a checksum over any address range; however, the test function, `ck_add`, assumes that the start and end address of the range being summed are a multiple of the `readType` width. (Clearly this is a non-issue if the size of `readType` is 1.) It is recommended that your checksum specification adheres to this assumption, otherwise you will need to modify the test code to perform partial reads of the starting and/or ending data values. This will significantly increase the code complexity.

## 8.4.2 Subtraction Algorithms

HEXMATE has several checksum algorithms that subtract data values over a range in the program image. These algorithms correspond to the selector values -1, -2, -3, and -4 in the `algorithm` suboption and read the data in the program image as 1-, 2-, 3- or 4-byte quantities, respectively. In other respects, these algorithms are identical to the addition algorithms described in [Section 8.4.1 "Addition Algorithms"](#).

The function shown below can be customized to work with any combination of data size (`readType`) and checksum width (`resultType`).

```
typedef unsigned char readType; // size of data values read and summed
typedef unsigned int  resultType; // size of checksum result

// add to offset n subtractions of values starting at address data,
// truncating and returning the result
// data: the address of the first value to subtract
// n:    the number of subtractions to perform
// offset: the initial value to which the subtraction is added
resultType ck_sub(const readType *data, unsigned n, resultType offset)
{
    resultType chksum;

    chksum = offset;
    while(n--) {
        chksum -= *data;
        data++;
    }
    return chksum;
}
```

Here is how this function might be used when, for example, a 4-byte-wide checksum is to be calculated from the addition of 2-byte-wide values over the address range 0x0 to 0x7fd, starting with an offset of 0x0. The checksum is to be stored at 0x7fe and 0x7ff in little endian format. The following option is specified when building the project. (In MPLAB X IDE, only enter the information to the right of the first = in the Checksum field in the Additional options Option category in the XC8 Linker category.)

```
--CHECKSUM=0-7fd@7fe,offset=0,algorithm=-2,width=-4
```

Into your project add the following code snippet, which calls `ck_sub`, above, and compare the runtime checksum with that stored by HEXMATE at compile time.

```
extern const readType ck_range[0x7fe/sizeof(readType)] @ 0x0;
extern const resultType hexmate @ 0x7fe;
resultType result;

result = ck_sub(ck_range, sizeof(ck_range)/sizeof(readType), 0x0);
if(result != hexmate)
    ck_failure(); // take appropriate action
```

### 8.4.3 Fletcher Algorithms

HEXMATE has several algorithms that implement Fletcher's checksum. These algorithms are more complex, providing a robustness approaching that of a cyclic redundancy check, but with less computational effort. There are two forms of this algorithm, which correspond to the selector values 7 and 8 in the `algorithm` suboption, and which implement a 1-byte calculation and 2-byte result, and a 2-byte calculation and 4-byte result, respectively. HEXMATE will automatically store the checksum in the HEX file at the address specified in the checksum option.

The function shown below performs a 1-byte-wide addition and produces a 2-byte result.

```
unsigned int
fletcher8(const unsigned char * data, unsigned int n )
{
    unsigned int sum = 0xff, sumB = 0xff;
    unsigned char tlen;

    while (n) {
        tlen = n > 20 ? 20 : n;
        n -= tlen;
        do {
            sumB += sum += *data++;
        } while (--tlen);
        sum = (sum & 0xff) + (sum >> 8);
        sumB = (sumB & 0xff) + (sumB >> 8);
    }
    sum = (sum & 0xff) + (sum >> 8);
    sumB = (sumB & 0xff) + (sumB >> 8);

    return sumB << 8 | sum;
}
```

This code can be called in a manner similar to that shown for the addition algorithms, see [Section 8.4.1 "Addition Algorithms"](#).

The code for the 2-byte-addition Fletcher algorithm, producing a 4-byte result is shown below.

```
unsigned long
fletcher16(const unsigned int * data, unsigned n)
{
    unsigned long sum = 0xffff, sumB = 0xffff;
    unsigned tlen;

    while (n) {
        tlen = n > 359 ? 359 : n;
        n -= tlen;
        do {
            sumB += sum += *data++;
        } while (--tlen);
        sum = (sum & 0xffff) + (sum >> 16);
        sumB = (sumB & 0xffff) + (sumB >> 16);
    }
    sum = (sum & 0xffff) + (sum >> 16);
    sumB = (sumB & 0xffff) + (sumB >> 16);

    return sumB << 16 | sum;
}
```

## 8.4.4 CRC Algorithms

HEXMATE has several algorithms that implement the robust cyclic redundancy checks (CRC). There is a choice of two algorithms that correspond to the selector values 5 and -5 in the `algorithm` suboption to `--CHECKSUM`, and that implement a CRC calculation and reflected CRC calculation, respectively. The reflected algorithm works on the least significant bit of the data first. The polynomial to be used and the initial value can be specified in the option. HEXMATE will automatically store the CRC result in the HEX file at the address specified in the checksum option.

The function shown below can be customized to work with any result width (`resultType`). It calculates a CRC hash value using the polynomial specified by the `POLYNOMIAL` macro.

```
typedef unsigned int resultType;
#define POLYNOMIAL    0x1021
#define WIDTH      (8 * sizeof(resultType))
#define MSb        ((resultType)1 << (WIDTH - 1))

resultType
crc(const unsigned char * data, unsigned n, resultType remainder) {
    unsigned pos;
    unsigned char bitp;

    for (pos = 0; pos != n; pos++) {
        remainder ^= ((resultType)data[pos] << (WIDTH - 8));
        for (bitp = 8; bitp > 0; bitp--) {
            if (remainder & MSb) {
                remainder = (remainder << 1) ^ POLYNOMIAL;
            } else {
                remainder <<= 1;
            }
        }
    }

    return remainder;
}
```

The `resultType` type definition should be adjusted to suit the result width. When using MPLAB XC8 and for a size of 1, use a `char` type; for a size of 3, use a `short long` type, etc., or consider using the exact-width types provided by `<stdint.h>`.

Here is how this function might be used when, for example, a 2-byte-wide CRC hash value is to be calculated values over the address range 0x0 to 0xFF, starting with an initial value of 0xFFFF. The result is to be stored at 0x100 and 0x101 in little endian format. The following option is specified when building the project. (In MPLAB X IDE, only enter the information to the right of the first = in the Checksum field in the Additional options Option category in the XC8 Linker category.)

```
--CHECKSUM=0-FF@100,offset=0xFFFF,algorithm=5,width=-2,polynomial=0x1021
```



Into your project, add the following code snippet, which calls `crc()`, above, and compares the runtime hash result with that stored by HEXMATE at compile time.

```
extern const unsigned char ck_range[0x100] @ 0x0;
extern const resultType hexmate @ 0x100;
resultType result;

result = crc(ck_range, sizeof(ck_range), 0xFFFF);
if(result != hexmate){
    // something's not right, take appropriate action
    ck_failure();
}
// data verifies okay, continue with the program
```

The reflected CRC result can be calculated by reflecting the input data and final result, or by reflecting the polynomial. The functions shown below can be customized to work with any result width (`resultType`). The `crc_reflected_IO()` function calculates a reflected CRC hash value by reflecting the data stream bit positions. The `crc_reflected_poly()` function does not adjust the data stream but reflects instead the polynomial, which in both functions is specified by the `POLYNOMIAL` macro. Both functions use the `reflect()` function to perform bit reflection.

```
typedef unsigned int resultType;
typedef unsigned char readType;
typedef unsigned int reflectWidth;

// This is the polynomial used by the CRC-16 algorithm we are using.
#define POLYNOMIAL    0x1021

#define WIDTH    (8 * sizeof(resultType))
#define MSB      ((resultType)1 << (WIDTH - 1))
#define LSB      (1)

#define REFLECT_DATA(X)      ((readType) reflect((X), 8))
#define REFLECT_REMAINDER(X) (reflect((X), WIDTH))

reflectWidth
reflect(reflectWidth data, unsigned char nBits)
{
    reflectWidth reflection = 0;
    reflectWidth reflectMask = (reflectWidth)1 << nBits - 1;
    unsigned char bitp;

    for (bitp = 0; bitp != nBits; bitp++) {
        if (data & 0x01) {
            reflection |= reflectMask;
        }
        data >>= 1;
        reflectMask >>= 1;
    }

    return reflection;
}
```

# MPLAB® XC8 C Compiler User's Guide

---

```
resultType
crc_reflected_IO(const unsigned char * data, unsigned n, resultType
remainder) {
    unsigned pos;
    unsigned char reflected;
    unsigned char bitp;

    for (pos = 0; pos != n; pos++) {
        reflected = REFLECT_DATA(data[pos]);
        remainder ^= ((resultType)reflected << (WIDTH - 8));

        for (bitp = 8; bitp > 0; bitp--) {
            if (remainder & MSb) {
                remainder = (remainder << 1) ^ POLYNOMIAL;
            } else {
                remainder <<= 1;
            }
        }
    }
    remainder = REFLECT_REMAINDER(remainder);

    return remainder;
}

resultType
crc_reflected_poly(const unsigned char * data, unsigned n, resultType
remainder) {
    unsigned pos;
    unsigned char bitp;
    resultType rpoly;

    rpoly = reflect(POLYNOMIAL, WIDTH);
    for (pos = 0; pos != n; pos++) {
        remainder ^= data[pos];

        for (bitp = 8; bitp > 0; bitp--) {
            if (remainder & LSb) {
                remainder = (remainder >> 1) ^ rpoly;
            } else {
                remainder >>= 1;
            }
        }
    }

    return remainder;
}
```

Here is how this function might be used when, for example, a 2-byte-wide reflected CRC result is to be calculated over the address range 0x0 to 0xFF, starting with an initial value of 0xFFFF. The result is to be stored at 0x100 and 0x101 in little endian format. The following option is specified when building the project. (Note the algorithm selected is *negative 5* in this case.)

```
--CHECKSUM=0-FF@100,offset=0xFFFF,algorithm=-5,width=-2,polynomial=0x1021
```

Into your project, call `crc()`, as shown previously.

---

---

## Appendix A. Library Functions

---

---

### A.1 INTRODUCTION

The functions and preprocessor macros within the standard compiler library are alphabetically listed in this chapter.

The synopsis indicates the header file in which a declaration or definition for function or macro is found. It also shows the function prototype for functions, or the equivalent prototype for macros.

Note that where `printf()` is shown in example code, this assumes that the `putch()` function has been defined to suit the peripheral that will act as the `stdout` stream. Initialization of that peripheral must also be performed before you attempt to print.

### **\_\_BUILTIN\_SOFTWARE\_BREAKPOINT**

#### **Synopsis**

```
#include <xc.h>

void __builtin_software_breakpoint(void);
```

#### **Description**

This builtin unconditionally inserts code into the program output which triggers a software breakpoint when the code is executed using a debugger.

The software breakpoint code is only generated for mid-range and PIC18 devices. Baseline devices do not support software breakpoints in this way, and the builtin will be ignored if used with these devices.

#### **Example**

```
#include <xc.h>

int
main (void)
{
    __builtin_software_breakpoint(); // stop here to begin
    ...
}
```

#### **See also**

```
__debug_break()
```

## \_\_CONDITIONAL\_SOFTWARE\_BREAKPOINT

### Synopsis

```
#include <assert.h>

__conditional_software_breakpoint(expression)
```

### Description

This macro implements a light-weight embedded version of the standard C `assert()` macro, and is used in the same way.

When executed, the *expression* argument is evaluated. If the argument is false the macro attempts to halt program execution; the macro performs no action if the argument is true.

The macro is removed from the program output if the manifest constant `NDEBUG` is defined. In addition, it is included only for debug builds (i.e., when the `__DEBUG` macro is defined). Thus, it does not consume device resources for production builds.

If the target device does not support the ability to halt via a software breakpoint, use of this macro will trigger a compiler error.

### Example

```
#include <assert.h>

void getValue(int * ip) {
    __conditional_software_breakpoint(ip != NULL);
    ...
}
```

### See also

`ASSERT()`, `__builtin_software_breakpoint()`

## **\_\_CONFIG (BASELINE & MID-RANGE DEVICES)**

### **Synopsis**

```
#include <xc.h>
```

```
__CONFIG (data)
```

### **Description**

This macro is provided for legacy support only. Use the `#pragma config` for new projects.

This macro is used to program the Configuration fuses that set the device's operating modes.

The macro assumes the argument is a 16-bit value, which will be used to program the Configuration bits.

16-bit masks have been defined to describe each programmable attribute available on each device. These masks can be found in the chip-specific header files included via `<xc.h>`.

Multiple attributes can be selected by ANDing them together.

### **Example**

```
#include <xc.h>
```

```
__CONFIG (RC & UNPROTECT)
```

```
void  
main (void)  
{  
}  
}
```

### **See also**

```
__EEPROM_DATA (), __IDLOC (), __IDLOC7 (), CONFIG () (PIC18),  
#pragma config
```

## \_\_CONFIG (PIC18)

### Synopsis

```
#include <xc.h>

__CONFIG(num, data)
```

### Description

This macro is provided for legacy support only. Use the `#pragma config` for new projects.

This macro is used to program the Configuration fuses that set the device's operating modes.

The macro accepts the number corresponding to the Configuration register it is to program, then the 16-bit value it is to update it with.

16-bit masks have been defined to describe each programmable attribute available on each device. These masks can be found in the chip-specific header files included via `<xc.h>`.

Multiple attributes can be selected by ANDing them together.

### Example

```
#include <xc.h>

__CONFIG(1,RC & OSCEN)
__CONFIG(2,WDTPS16 & BORV45)
__CONFIG(4, DEBUGEN)

void
main (void)
{
}
```

### See also

`__EEPROM_DATA()`, `__IDLOC()`, `__IDLOC7()`, `CONFIG()`  
(baseline & mid-range devices), `#pragma config`

## **\_\_DEBUG\_BREAK**

### **Synopsis**

```
#include <xc.h>

void __debug_break(void);
```

### **Description**

This macro conditionally inserts code into the program output which triggers a software breakpoint when the code is executed using a debugger. The code is only generated for debug builds (see [Section 3.3.9 “What is Different About an MPLAB X IDE Debug Build?”](#)) and is omitted for production builds (i.e., when the `__DEBUG` macro is defined).

The software breakpoint code is only generated for mid-range and PIC18 devices. Baseline devices do not support software breakpoints in this way, and the macro will be ignored if used with these devices.

### **Example**

```
#include <xc.h>

int
main (void)
{
    __debug_break(); // stop here to begin
    ...
}
```

### **See also**

`__builtin_software_breakpoint()`

## **\_\_DELAY\_MS, \_\_DELAY\_US, \_\_DELAYWDT\_US, \_\_DELAYWDT\_MS**

### **Synopsis**

```
__delay_ms(x) // request a delay in milliseconds
__delay_us(x) // request a delay in microseconds
__delaywdt_ms(x) // request a delay in milliseconds
__delaywdt_us(x) // request a delay in microseconds
```

### **Description**

It is often more convenient to request a delay in time-based terms, rather than in cycle counts. The macros `__delay_ms(x)` and `__delay_us(x)` are provided to meet this need. These macros convert the time-based request into instruction cycles that can be used with `_delay(n)`. In order to achieve this, these macros require the prior definition of preprocessor macro `_XTAL_FREQ`, which indicates the system frequency. This macro should equate to the oscillator frequency (in hertz) used by the system. Note that this macro only controls the behavior of these delays and does not affect the device execution speed.

On PIC18 devices only, you can use the alternate WDT-form of these functions, which uses the `CLRWDT` instruction as part of the delay code. See the `_delaywdt` function.

The macro argument must be a constant expression. An error will result if these macros are used without defining the oscillator frequency symbol, the delay period requested is too large, or the delay period is not a constant.

### **See also**

`_delay()`, `_delaywdt()`

## \_\_EEPROM\_DATA

### Synopsis

```
#include <xc.h>

__EEPROM_DATA(a,b,c,d,e,f,g,h)
```

### Description

This macro is used to store initial values in the device's EEPROM registers at the time of programming.

The macro must be given blocks of 8 bytes to write each time it is called, and can be called repeatedly to store multiple blocks.

`__EEPROM_DATA()` will begin writing to EEPROM address zero, and auto-increments the address written to by 8 each time it is used.

### Example

```
#include <xc.h>

__EEPROM_DATA(0x00,0x01,0x02,0x03,0x04,0x05,0x06,0x07)
__EEPROM_DATA(0x08,0x09,0x0A,0x0B,0x0C,0x0D,0x0E,0x0F)

void
main (void)
{
}
```

### See also

`__CONFIG()`



## \_\_FPNORMALIZE

### Synopsis

```
#include <xc.h>
```

```
double __fpnormalize(double fnum)
```

### Description

This function can be used to ensure that an arbitrary 32-bit floating-point value (which is not the result of a calculation performed by the compiler) conforms to the "relaxed" floating-point rules, as described in [Section 5.4.3 "Floating-Point Data Types"](#).

This function returns the value passed to it, but ensures that any subnormal argument is flushed to zero, and converts any negative zero argument to a positive zero result.

### Example

```
#include <xc.h>
```

```
void  
main (void)  
{  
    double input_fp;  
  
    // read in a floating-point value from an external source  
    input_fp = getFP();  
    // ensure it is formatted using the relaxed rules  
    input_fp = __fpnormalize(input_fp);  
    ...  
}
```

## \_\_IDLOC

### Synopsis

```
#include <xc.h>
```

```
__IDLOC(x)
```

### Description

This macro is provided for legacy support only. Use the `#pragma config` for new projects.

This macro places data into the device's special locations, outside of addressable memory, that is reserved for ID. This would be useful for storage of serial numbers, etc.

The macro will attempt to write 4 nibbles of data to the 4 ID locations.

### Example

```
#include <xc.h>
```

```
__IDLOC(15F0); /* stores 1, 5, F and 0 in the ID registers */
```

```
void  
main (void)  
{  
}  
}
```

### See also

```
__IDLOC7(), __CONFIG()
```

## \_\_IDLOC7

### Synopsis

```
#include <xc.h>

__IDLOC7 (a, b, c, d)
```

### Description

This macro is provided for legacy support only. Use the `#pragma config` for new projects.

This macro places data into the device's special locations, outside of addressable memory, that is reserved for ID. This would be useful for storage of serial numbers, etc.

The macro will attempt to write 7 bits of data to each of the 4 locations reserved for ID purposes.

### Example

```
#include <xc.h>

/* will store 7Fh, 70, 1 and 5Ah in the ID registers */
__IDLOC (0x7F, 70, 1, 0x5A);

void
main (void)
{
}
```

### Note

Not all devices permit 7-bit programming of the ID locations. Refer to the device data sheet to see whether this macro can be used on your particular device.

### See also

```
__IDLOC (), __CONFIG ()
```

## **\_\_OSCCAL\_VAL**

### **Synopsis**

```
#include <xc.h>
```

```
unsigned char __osccal_val(void);
```

### **Description**

This is a pseudo-function that is defined by the code generator to be a label only. The label's value is equated to the address of the `RETLW` instruction, which encapsulates the oscillator configuration value. This function is only available for those devices that are shipped with such a value stored in program memory.

Calls to the function will return the device's oscillator configuration value, which can then be used in any expression, if required.

Note that this function is automatically called by the runtime start-up code (unless you have explicitly disabled this option, see [Section 4.8.54 "--RUNTIME: Specify Runtime Environment"](#)) and you do not need to call it to calibrate the internal oscillator.

### **Example**

```
#include <xc.h>

void
main (void)
{
    unsigned char c;
    c = __osccal_val();
}
```

## `_DELAY()` , `_DELAYWDT`

### Synopsis

```
#include <xc.h>

void _delay(unsigned long cycles);
void _delaywdt(unsigned long cycles);
```

### Description

This is an in-line function that is expanded by the code generator. When called, this routine expands to an in-line assembly delay sequence. The sequence will consist of code that delays for the number of instruction cycles that is specified as the argument. The argument must be a constant expression.

The `_delay` in-line function can use loops and the `NOP` instruction to implement the delay. The `_delaywdt` in-line function performs the same task, but will use the `CLRWDT` instruction, as well as loops, to achieve the specified delay.

An error will result if the delay period requested is not a constant expression or is too large (greater than 50,463,240 instructions). For even larger delays, call this function multiple times.

### Example

```
#include <xc.h>

void
main (void)
{
    control |= 0x80;
    _delay(10);    // delay for 10 cycles
    control &= 0x7F;
}
```

### See Also

`_delay3()` , `__delay_us()` , `__delay_ms()`

## **\_DELAY3()**

### **Synopsis**

```
#include <xc.h>

void _delay3(unsigned char cycles);
```

### **Description**

This is an in-line function that is expanded by the code generator. It is only available on PIC18 and enhanced mid-range devices. When called, this routine expands to an in-line assembly delay sequence. The sequence will consist of code that delays for 3 times the number of cycles that is specified as argument, assuming that the argument can be loaded to WREG in one instruction, and that there are no errata-workaround NOPs present in the loop. If this is not the case, the delay will be longer. The argument can be a byte-sized constant or variable.

### **Example**

```
#include <xc.h>

void
main (void)
{
    control |= 0x80;
    _delay3(10);    // delay for 30 cycles
    control &= 0x7F;
}
```

### **See Also**

[\\_delay](#)

## **ABS**

### **Synopsis**

```
#include <stdlib.h>

int abs (int j)
```

### **Description**

The `abs()` function returns the absolute value of `j`.

### **Example**

```
#include <stdio.h>
#include <stdlib.h>

void
main (void)
{
    int a = -5;
    printf("The absolute value of %d is %d\n", a, abs(a));
}
```

### **See Also**

[labs\(\)](#), [fabs\(\)](#)

### **Return Value**

The absolute value of `j`.

## ACOS

### Synopsis

```
#include <math.h>
```

```
double acos (double f)
```

### Description

The `acos()` function implements the inverse of `cos()`; i.e., it is passed a value in the range -1 to +1, and returns an angle in radians that's cosine is equal to that value.

### Example

```
#include <math.h>
#include <stdio.h>

/* Print acos() values for -1 to 1 in degrees. */

void
main (void)
{
    float i, a;

    for(i = -1.0; i < 1.0 ; i += 0.1) {
        a = acos(i)*180.0/3.141592;
        printf("acos(%f) = %f degrees\n", i, a);
    }
}
```

### See Also

`sin()`, `cos()`, `tan()`, `asin()`, `atan()`, `atan2()`

### Return Value

An angle in radians, in the range 0 to  $\pi$

## ASCTIME

### Synopsis

```
#include <time.h>

char * asctime (struct tm * t)
```

### Description

The `asctime()` function takes the time broken down into the `struct tm` structure, pointed to by its argument, and returns a 26 character string describing the current date and time in the format:

```
Sun Sep 16 01:03:52 1973\n\n0
```

Note the newline at the end of the string. The width of each field in the string is fixed. The example gets the current time, converts it to a `struct tm` with `localtime()`, it then converts this to ASCII and prints it. The `time()` function will need to be provided by the user (see `time()` for details).

### Example

```
#include <stdio.h>
#include <time.h>

void
main (void)
{
    time_t clock;
    struct tm * tp;

    time(&clock);
    tp = localtime(&clock);
    printf("%s", asctime(tp));
}
```

### See Also

`ctime()`, `gmtime()`, `localtime()`, `time()`

### Return Value

A pointer to the string.

### Note

The example will require the user to provide the `time()` routine as it cannot be supplied with the compiler. See `time()` for more details.

## ASIN

### Synopsis

```
#include <math.h>

double asin (double f)
```

### Description

The `asin()` function implements the converse of `sin()`; i.e., it is passed a value in the range -1 to +1, and returns an angle in radians whose sine is equal to that value.

### Example

```
#include <math.h>
#include <stdio.h>

void
main (void)
{
    float i, a;

    for(i = -1.0; i < 1.0 ; i += 0.1) {
        a = asin(i)*180.0/3.141592;
        printf("asin(%f) = %f degrees\n", i, a);
    }
}
```

### See Also

`sin()`, `cos()`, `tan()`, `acos()`, `atan()`, `atan2()`

### Return Value

An angle in radians, in the range  $-\pi/2 - \pi/2$ .



## ASSERT

### Synopsis

```
#include <assert.h>
```

```
void assert (int e)
```

### Description

This macro is used for debugging purposes; the basic method of usage is to place assertions liberally throughout your code at points where correct operation of the code depends upon certain conditions being true initially. An `assert()` routine can be used to ensure at runtime that an assumption holds true. For example, the following statement asserts that `mode` is larger than zero:

```
assert(mode > 0);
```

If the expression passed to `assert()` evaluates to false at runtime, the macro attempts to print diagnostic information and abort the program. A fuller discussion of the uses of `assert()` is impossible in limited space, but it is closely linked to methods of proving program correctness.

The `assert()` macro depends on the implementation of the function `_fassert()`. The default `_fassert()` function, built into the library files, first calls the `printf()` function, which prints a message identifying the source file and line number of the assertion. Next, `_fassert()` attempts to terminate program execution by calling `abort()`. The exact behaviour of `abort()` is dependent on the selected device and whether the executable is a debug or production build. For debug builds, `abort()` will consist of a software breakpoint instruction followed by a Reset instruction, if possible. For production builds, `abort()` will consist only of a Reset instruction, if possible. In both cases, if a Reset instruction is not available, a goto instruction that jumps to itself in an endless loop is output.

The `_fassert()` routine can be adjusted to ensure it meets your application needs. Include the source file defining this function into your project, if you modify it.

### Example

```
#include <assert.h>
```

```
void  
ptrfunc (struct xyz * tp)  
{  
    assert(tp != 0);  
}
```

## ATAN

### Synopsis

```
#include <math.h>

double atan (double x)
```

### Description

This function returns the arc tangent of its argument; i.e., it returns an angle 'e' in the range  $-\pi/2 - \pi/2$ .

### Example

```
#include <stdio.h>
#include <math.h>

void
main (void)
{
    printf("atan(%f) is %f\n", 1.5, atan(1.5));
}
```

### See Also

sin(), cos(), tan(), asin(), acos(), atan2()

### Return Value

The arc tangent of its argument.

## ATAN2

### Synopsis

```
#include <math.h>

double atan2 (double x, double x)
```

### Description

This function returns the arc tangent of  $y/x$ .

### Example

```
#include <stdio.h>
#include <math.h>

void
main (void)
{
    printf("atan2(%f, %f) is %f\n", 10.0, -10.0, atan2(10.0,
-10.0));
}
```

### See Also

sin(), cos(), tan(), asin(), acos(), atan()

### Return Value

The arc tangent of  $y/x$ .

## ATOF

### Synopsis

```
#include <stdlib.h>
```

```
double atof (const char * s)
```

### Description

The `atof()` function scans the character string passed to it, skipping leading blanks. It then converts an ASCII representation of a number to a double. The number can be in decimal, normal floating point or scientific notation.

### Example

```
#include <stdlib.h>
```

```
#include <stdio.h>
```

```
void  
main (void)  
{  
    char buf[80];  
    double i;  
  
    gets(buf);  
    i = atof(buf);  
    printf("Read %s: converted to %f\n", buf, i);  
}
```

### See Also

`atoi()`, `atol()`, `strtod()`

### Return Value

A double precision floating-point number. If no number is found in the string, 0.0 will be returned.

## ATOI

### Synopsis

```
#include <stdlib.h>
```

```
int atoi (const char * s)
```

### Description

The `atoi()` function scans the character string passed to it, skipping leading blanks and reading an optional sign. It then converts an ASCII representation of a decimal number to an integer.

### Example

```
#include <stdlib.h>
```

```
#include <stdio.h>
```

```
void
```

```
main (void)
```

```
{
```

```
    char buf[80];
```

```
    int i;
```

```
    gets(buf);
```

```
    i = atoi(buf);
```

```
    printf("Read %s: converted to %d\n", buf, i);
```

```
}
```

### See Also

`xtoi()`, `atof()`, `atol()`

### Return Value

A signed integer. If no number is found in the string, 0 will be returned.

## ATOL

### Synopsis

```
#include <stdlib.h>
```

```
long atol (const char * s)
```

### Description

The `atol()` function scans the character string passed to it, skipping leading blanks. It then converts an ASCII representation of a decimal number to a long integer.

### Example

```
#include <stdlib.h>
#include <stdio.h>
```

```
void
main (void)
{
    char buf[80];
    long i;

    gets(buf);
    i = atol(buf);
    printf("Read %s: converted to %ld\n", buf, i);
}
```

### See Also

`atoi()`, `atof()`

### Return Value

A long integer. If no number is found in the string, 0 will be returned.

## BSEARCH

### Synopsis

```
#include <stdlib.h>
```

```
void * bsearch (const void * key, void * base, size_t n_memb,  
size_t size, int (*compar)(const void *, const void *))
```

### Description

The `bsearch()` function searches a sorted array for an element matching a particular key. It uses a binary search algorithm, calling the function pointed to by `compar` to compare elements in the array.

### Example

```
#include <stdlib.h>  
#include <stdio.h>  
#include <string.h>  
  
struct value {  
    char name[10];  
    int value;  
} values[] = {  
    { "foobar", 66 };  
    { "casbar", 87 };  
    { "crossbar", 105 };  
};  
  
int  
val_cmp (const void * p1, const void * p2) {  
    return strcmp(((const struct value *)p1)->name,  
                ((const struct value *)p2)->name);  
}  
  
void  
main (void) {  
    int i = sizeof(values)/sizeof(struct value);  
    struct value * vp;  
  
    qsort(values, i, sizeof values[0], val_cmp);  
    vp = bsearch("fred", values, i, sizeof values[0], val_cmp);  
    if(!vp)  
        printf("Item 'fred' was not found\n");  
    else  
        printf("Item 'fred' has value %d\n", vp->value);  
}
```

### See Also

`qsort()`

### Return Value

A pointer to the matched array element (if there is more than one matching element, any of these can be returned). If no match is found, a null is returned.

### Note

The comparison function must have the correct prototype.

## CEIL

### Synopsis

```
#include <math.h>
```

```
double ceil (double f)
```

### Description

This routine returns the smallest whole number not less than  $f$ .

### Example

```
#include <stdio.h>
#include <math.h>
#include <stdlib.h>
```

```
void
main (void)
{
    double j;

    j = 2.345 * rand()
    printf("The ceiling of %f is %f\n", j, ceil(j));
}
```

## CGETS

### Synopsis

```
#include <conio.h>
```

```
char * cgets (char * s)
```

### Description

The `cgets()` function will read one line of input from the console into the buffer passed as an argument. It does so by repeated calls to `getche()`. As characters are read, they are buffered, with backspace deleting the previously typed character, and ctrl-U deleting the entire line typed so far. Other characters are placed in the buffer, with a carriage return or line feed (newline) terminating the function. The collected string is null terminated.

### Example

```
#include <conio.h>
#include <string.h>

char buffer[80];

void
main (void)
{
    for(;;) {
        cgets(buffer);
        if(strcmp(buffer, "exit" == 0)
            break;
        cputs("Type 'exit' to finish\n");
    }
}
```

### See Also

`getch()`, `getche()`, `putch()`, `cputs()`

### Return Value

The return value is the character passed as the sole argument.



## CLRWDT

### Synopsis

```
#include <xc.h>
```

```
CLRWDT();
```

### Description

This macro is used to clear the device's internal watchdog timer.

### Example

```
#include <xc.h>

void
main (void)
{
    WDTCON=1;
    /* enable the WDT */

    CLRWDT();
}
```

## COS

### Synopsis

```
#include <math.h>
```

```
double cos (double f)
```

### Description

This function yields the cosine of its argument, which is an angle in radians. The cosine is calculated by expansion of a polynomial series approximation.

### Example

```
#include <math.h>
#include <stdio.h>

#define C 3.141592/180.0

void
main (void)
{
    double i;

    for(i = 0 ; i <= 180.0 ; i += 10)
        printf("sin(%3.0f) = %f, cos = %f\n", i, sin(i*C),
cos(i*C));
}
```

### See Also

`sin()`, `tan()`, `asin()`, `acos()`, `atan()`, `atan2()`

### Return Value

A double in the range -1 to +1.

## COSH, SINH, TANH

### Synopsis

```
#include <math.h>

double cosh (double f)
double sinh (double f)
double tanh (double f)
```

### Description

These functions implement hyperbolic equivalents of the trigonometric functions; `cos()`, `sin()` and `tan()`.

### Example

```
#include <stdio.h>
#include <math.h>

void
main (void)
{
    printf("%f\n", cosh(1.5));
    printf("%f\n", sinh(1.5));
    printf("%f\n", tanh(1.5));
}
```

### Return Value

The function `cosh()` returns the hyperbolic cosine value.

The function `sinh()` returns the hyperbolic sine value.

The function `tanh()` returns the hyperbolic tangent value.

## CPUTS

### Synopsis

```
#include <conio.h>
```

```
void cputs (const char * s)
```

### Description

The `cputs()` function writes its argument string to the console, outputting carriage returns before each newline in the string. It calls `putch()` repeatedly. On a hosted system `cputs()` differs from `puts()` in that it writes to the console directly, rather than using file I/O. In an embedded system `cputs()` and `puts()` are equivalent.

### Example

```
#include <conio.h>
#include <string.h>

char buffer[80];

void
main (void)
{
    for(;;) {
        cgets(buffer);
        if(strcmp(buffer, "exit" == 0)
            break;
        cputs("Type 'exit' to finish\n");
    }
}
```

### See Also

`cputs()`, `puts()`, `putch()`

## CTIME

### Synopsis

```
#include <time.h>

char * ctime (time_t * t)
```

### Description

The `ctime()` function converts the time in seconds pointed to by its argument to a string of the same form as described for `asctime()`. Thus the example program prints the current time and date.

### Example

```
#include <stdio.h>
#include <time.h>

void
main (void)
{
    time_t clock;

    time(&clock);
    printf("%s", ctime(&clock));
}
```

### See Also

`gmtime()`, `localtime()`, `asctime()`, `time()`

### Return Value

A pointer to the string.

### Note

The example will require the user to provide the `time()` routine as one cannot be supplied with the compiler. See `time()` for more detail.

## DI, EI

### Synopsis

```
#include <xc.h>

void ei (void)
void di (void)
```

### Description

The `di()` and `ei()` routines disable and re-enable interrupts respectively. These are implemented as macros. The example shows the use of `ei()` and `di()` around access to a long variable that is modified during an interrupt. If this was not done, it would be possible to return an incorrect value, if the interrupt occurred between accesses to successive words of the count value.

The `ei()` macro should never be called in an interrupt function, and there is no need to call `di()` in an interrupt function.

### Example

```
#include <xc.h>

long count;

void
interrupt tick (void)
{
    count++;
}

long
getticks (void)
{
    long val;    /* Disable interrupts around access
                 to count, to ensure consistency.*/
    di();
    val = count;
    ei();
    return val;
}
```

## DIV

### Synopsis

```
#include <stdlib.h>

div_t div (int numer, int denom)
```

### Description

The `div()` function computes the quotient and remainder of the numerator divided by the denominator.

### Example

```
#include <stdlib.h>
#include <stdio.h>

void
main (void)
{
    div_t x;

    x = div(12345, 66);
    printf("quotient = %d, remainder = %d\n", x.quot, x.rem);
}
```

### See Also

`udiv()`, `ldiv()`, `uldiv()`

### Return Value

Returns the quotient and remainder into the `div_t` structure.

## EEPROM ROUTINES

### Description

These functions can now be generated by MPLAB Code Configurator.

## EVAL\_POLY

### Synopsis

```
#include <math.h>
```

```
double eval_poly (double x, const double * d, int n)
```

### Description

The `eval_poly()` function evaluates a polynomial, whose coefficients are contained in the array `d`, at `x`, for example:

$$y = x*x*d2 + x*d1 + d0.$$

The order of the polynomial is passed in `n`.

### Example

```
#include <stdio.h>
#include <math.h>
```

```
void
main (void)
{
    double x, y;
    double d[3] = {1.1, 3.5, 2.7};

    x = 2.2;
    y = eval_poly(x, d, 2);
    printf("The polynomial evaluated at %f is %f\n", x, y);
}
```

### Return Value

A double value, being the polynomial evaluated at `x`.

## EXP

### Synopsis

```
#include <math.h>
```

```
double exp (double f)
```

### Description

This function returns the exponential function of its argument; i.e.,  $e$  to the power of `f`.

### Example

```
#include <math.h>
#include <stdio.h>
```

```
void
main (void)
{
    printf("e to 2.0 = %f\n", exp(2.0));
}
```

### See Also

`log()`, `log10()`, `pow()`

## FABS

### Synopsis

```
#include <math.h>

double fabs (double f)
```

### Description

This routine returns the absolute value of its double argument.

### Example

```
#include <stdio.h>
#include <math.h>

void
main (void)
{
    printf("%f %f\n", fabs(1.5), fabs(-1.5));
}
```

### See Also

abs(), labs()

## FLASH ROUTINES

### Description

These functions can now be generated by MPLAB<sup>®</sup> Code Configurator.



## FLOOR

### Synopsis

```
#include <math.h>

double floor (double f)
```

### Description

This routine returns the largest whole number not greater than  $f$ .

### Example

```
#include <stdio.h>
#include <math.h>

void
main (void)
{
    printf("%f\n", floor( 1.5 ));
    printf("%f\n", floor( -1.5));
}
```

## FMOD

### Synopsis

```
#include <math.h>

double fmod (double x, double y)
```

### Description

The function `fmod` returns the remainder of  $x/y$  as a floating-point quantity.

### Example

```
#include <math.h>

void
main (void)
{
    double rem, x;

    x = 12.34;
    rem = fmod(x, 2.1);
}
```

### Return Value

The floating-point remainder of  $x/y$ .

## FREXP

### Synopsis

```
#include <math.h>
```

```
double frexp (double f, int * p)
```

### Description

The `frexp()` function breaks a floating-point number into a normalized fraction and an integral power of 2. The integer is stored into the `int` object pointed to by `p`. Its return value `x` is in the interval (0.5, 1.0) or zero, and `f` equals `x` times 2 raised to the power stored in `*p`. If `f` is zero, both parts of the result are zero.

### Example

```
#include <math.h>
#include <stdio.h>
```

```
void
main (void)
{
    double f;
    int i;

    f = frexp(23456.34, &i);
    printf("23456.34 = %f * 2^%d\n", f, i);
}
```

### See Also

`ldexp()`

## FTOA

### Synopsis

```
#include <stdlib.h>
```

```
char * ftoa (float f, int * status)
```

### Description

The function `ftoa` converts the contents of `f` into a string which is stored into a buffer which is then return.

### Example

```
#include <stdlib.h>
#include <stdio.h>
```

```
void
main (void)
{
    char * buf;
    float input = 12.34;
    int status;
    buf = ftoa(input, &status);
    printf("The buffer holds %s\n", buf);
}
```

### See Also

```
strtol(), itoa(), utoa(), ultoa()
```

### Return Value

This routine returns a reference to the buffer into which the result is written.

## GETCH

### Synopsis

```
#include <conio.h>
```

```
char getch (void)
```

### Description

The `getch()` function is provided as an empty stub which can be completed as each project requires. Typically this function will read one byte of data from a peripheral that is associated with `stdin`, and return this value.

### Example

```
#include <conio.h>

char result;

void
main (void)
{
    result = getch();
}
```

### See Also

`getche()`, `getchar()`

## GETCHE

### Synopsis

```
#include <conio.h>
```

```
char getche (void)
```

### Description

The `getche()` function is provided as an empty stub which can be completed as each project requires. Typically this function will read one byte of data from a peripheral that is associated with `stdin`, and return this value. Unlike `getch()`, it should echo the received character. This function is independent of `getch()`, unless you should choose to implement it otherwise.

### Example

```
#include <conio.h>

char result;

void
main (void)
{
    result = getche();
}
```

### See Also

`getch()`, `getchar()`

## GETCHAR

### Synopsis

```
#include <stdio.h>
```

```
int getchar (void)
```

### Description

The `getchar()` routine usually reads from `stdin`, but is implemented as a call to `getche()`.

### Example

```
#include <stdio.h>
```

```
void  
main (void)  
{  
    int c;  
  
    while((c = getchar()) != EOF)  
        putchar(c);  
}
```

### See Also

`getc()`, `getche()`

### Note

This routine calls `getche()`.

## GETS

### Synopsis

```
#include <stdio.h>
```

```
char * gets (char * s)
```

### Description

The `gets()` function reads a line from standard input into the buffer at `s`, deleting the newline (compare: `fgets()`). The buffer is null terminated. In an embedded system, `gets()` is equivalent to `cgets()`, and results in `getche()` being called repeatedly to get characters. Editing (with backspace) is available.

### Example

```
#include <stdio.h>

void
main (void)
{
    char buf[80];

    printf("Type a line: ");
    if (gets (buf))
        puts (buf);
}
```

### See Also

`fgets()`, `freopen()`, `puts()`

### Return Value

It returns its argument, or NULL on end-of-file.

### Note

As you cannot specify a maximum number of characters to read with this function, it is unsafe to use.

## GET\_CAL\_DATA

### Synopsis

```
#include <xc.h>
```

```
double get_cal_data (const unsigned char * code_ptr)
```

### Description

This function returns the 32-bit floating-point calibration data from the PIC MCU 14000 calibration space. Only use this function to access `KREF`, `KBG`, `VHTHERM` and `KTC` (that is, the 32-bit floating-point parameters). `FOSC` and `TWDT` can be accessed directly as they are bytes.

### Example

```
#include <xc.h>
```

```
void  
main (void)  
{  
    double x;  
    unsigned char y;  
  
    /* Get the slope reference ratio. */  
    x = get_cal_data(KREF);  
  
    /* Get the WDT time-out. */  
    y = TWDT;  
}
```

### Return Value

The value of the calibration parameter

### Note

This function can only be used on the PIC14000.

## GMTIME

### Synopsis

```
#include <time.h>

struct tm * gmtime (time_t * t)
```

### Description

This function converts the time pointed to by `t` which is in seconds since 00:00:00 on Jan 1, 1970, into a broken down time stored in a structure as defined in `time.h`. The structure is defined in the 'Data Types' section.

### Example

```
#include <stdio.h>
#include <time.h>

void
main (void)
{
    time_t clock;
    struct tm * tp;

    time(&clock);
    tp = gmtime(&clock);
    printf("It's %d in London\n", tp->tm_year+1900);
}
```

### See Also

`ctime()`, `asctime()`, `time()`, `localtime()`

### Return Value

Returns a structure of type `tm`.

### Note

The example will require the user to provide the `time()` routine as one cannot be supplied with the compiler. See `time()` for more detail.



## ISALNUM, ISALPHA, ISDIGIT, ISLOWER, ET. AL.

### Synopsis

```
#include <ctype.h>

int isalnum (char c)
int isalpha (char c)
int isascii (char c)
int iscntrl (char c)
int isdigit (char c)
int islower (char c)
int isprint (char c)
int isgraph (char c)
int ispunct (char c)
int isspace (char c)
int isupper (char c)
int isxdigit (char c)
```

### Description

These macros, defined in `ctype.h`, test the supplied character for membership in one of several overlapping groups of characters. Note that all except `isascii()` are defined for `c`, if `isascii(c)` is true or if `c = EOF`.

<code>isalnum(c)</code>	<code>c</code> is in 0-9 or a-z or A-Z
<code>isalpha(c)</code>	<code>c</code> is in A-Z or a-z
<code>isascii(c)</code>	<code>c</code> is a 7 bit ASCII character
<code>iscntrl(c)</code>	<code>c</code> is a control character
<code>isdigit(c)</code>	<code>c</code> is a decimal digit
<code>islower(c)</code>	<code>c</code> is in a-z
<code>isprint(c)</code>	<code>c</code> is a printing char
<code>isgraph(c)</code>	<code>c</code> is a non-space printable character
<code>ispunct(c)</code>	<code>c</code> is not alphanumeric
<code>isspace(c)</code>	<code>c</code> is a space, tab or newline
<code>isupper(c)</code>	<code>c</code> is in A-Z
<code>isxdigit(c)</code>	<code>c</code> is in 0-9 or a-f or A-F

### Example

```
#include <ctype.h>
#include <stdio.h>

void
main (void)
{
    char buf[80];
    int i;

    gets(buf);
    i = 0;
    while (isalnum(buf[i]))
        i++;
    buf[i] = 0;
    printf("' %s' is the word\n", buf);
}
```

### See Also

`toupper()`, `tolower()`, `toascii()`

## ISDIG

### Synopsis

```
#include <ctype.h>
```

```
int isdig (int c)
```

### Description

The `isdig()` function tests the input character `c` to see if is a decimal digit (0 – 9) and returns true if this is the case; false otherwise.

### Example

```
#include <ctype.h>
```

```
void  
main (void)  
{  
    char buf[] = "1998a";  
    if (isdig(buf[0]))  
        printf(" type detected\n");  
}
```

### See Also

`isdigit()` (listed under `isalnum()`)

### Return Value

Zero if the character is a decimal digit; a non-zero value otherwise.

## ITOA

### Synopsis

```
#include <stdlib.h>
```

```
char * itoa (char * buf, int val, int base)
```

### Description

The function `itoa` converts the contents of `val` into a string which is stored into `buf`. The conversion is performed according to the radix specified in `base`. `buf` is assumed to reference a buffer which has sufficient space allocated to it.

### Example

```
#include <stdlib.h>  
#include <stdio.h>
```

```
void  
main (void) {  
    char buf[10];  
    itoa(buf, 1234, 16);  
    printf("The buffer holds %s\n", buf);  
}
```

### See Also

`strtol()`, `utoa()`, `ltoa()`, `ultoa()`

### Return Value

This routine returns a copy of the buffer into which the result is written.

## LABS

### Synopsis

```
#include <stdlib.h>
```

```
int labs (long int j)
```

### Description

The `labs()` function returns the absolute value of long value `j`.

### Example

```
#include <stdio.h>
#include <stdlib.h>
```

```
void
main (void)
{
    long int a = -5;

    printf("The absolute value of %ld is %ld\n", a, labs(a));
}
```

### See Also

`abs()`

### Return Value

The absolute value of `j`.

## LDEXP

### Synopsis

```
#include <math.h>
```

```
double ldexp (double f, int i)
```

### Description

The `ldexp()` function performs the inverse of `frexp()` operation; the integer `i` is added to the exponent of the floating-point `f` and the resultant returned.

### Example

```
#include <math.h>
#include <stdio.h>
```

```
void
main (void) {
    double f;

    f = ldexp(1.0, 10);
    printf("1.0 * 2^10 = %f\n", f);
}
```

### See Also

`frexp()`

### Return Value

The return value is the integer `i` added to the exponent of the floating-point value `f`.

## LDIV

### Synopsis

```
#include <stdlib.h>
```

```
ldiv_t ldiv (long number, long denom)
```

### Description

The `ldiv()` routine divides the numerator by the denominator, computing the quotient and the remainder. The sign of the quotient is the same as that of the mathematical quotient. Its absolute value is the largest integer which is less than the absolute value of the mathematical quotient.

The `ldiv()` function is similar to the `div()` function, the difference being that the arguments and the members of the returned structure are all of type `long int`.

### Example

```
#include <stdlib.h>
#include <stdio.h>
```

```
void
main (void)
{
    ldiv_t lt;

    lt = ldiv(1234567, 12345);
    printf("Quotient = %ld, remainder = %ld\n", lt.quot,
lt.rem);
}
```

### See Also

`div()`, `uldiv()`, `udiv()`

### Return Value

Returns a structure of type `ldiv_t`

## LOCALTIME

### Synopsis

```
#include <time.h>
```

```
struct tm * localtime (time_t * t)
```

### Description

The `localtime()` function converts the time pointed to by `t` which is in seconds since 00:00:00 on Jan 1, 1970, into a broken down time stored in a structure as defined in `time.h`. The routine `localtime()` takes into account the contents of the global integer `time_zone`. This should contain the number of minutes that the local time zone is westward of Greenwich. On systems where it is not possible to predetermine this value, `localtime()` will return the same result as `gmtime()`.

### Example

```
#include <stdio.h>
#include <time.h>
```

```
    char * wday[] = {
        "Sunday", "Monday", "Tuesday", "Wednesday",
        "Thursday", "Friday", "Saturday"
    };
```

```
void
main (void)
{
    time_t clock;
    struct tm * tp;

    time(&clock);
    tp = localtime(&clock);
    printf("Today is %s\n", wday[tp->tm_wday]);
}
```

### See Also

`ctime()`, `asctime()`, `time()`

### Return Value

Returns a structure of type `tm`.

### Note

The example will require the user to provide the `time()` routine as one cannot be supplied with the compiler. See `time()` for more detail.

## LOG, LOG10

### Synopsis

```
#include <math.h>

double log (double f)
double log10 (double f)
```

### Description

The `log()` function returns the natural logarithm of  $f$ . The function `log10()` returns the logarithm to base 10 of  $f$ .

### Example

```
#include <math.h>
#include <stdio.h>

void
main (void)
{
    double f;

    for(f = 1.0 ; f <= 10.0 ; f += 1.0)
        printf("log(%1.0f) = %f\n", f, log(f));
}
```

### See Also

`exp()`, `pow()`

### Return Value

Zero if the argument is negative.

## LONGJMP

### Synopsis

```
#include <setjmp.h>
```

```
void longjmp (jmp_buf buf, int val)
```

### Description

The `longjmp()` function, in conjunction with `setjmp()`, provides a mechanism for non-local goto's. To use this facility, `setjmp()` should be called with a `jmp_buf` argument in some outer level function. The call from `setjmp()` will return 0.

To return to this level of execution, `longjmp()` can be called with the same `jmp_buf` argument from an inner level of execution. However, the function that called `setjmp()` must still be active when `longjmp()` is called. Breach of this rule will cause errors, due to the use of a stack containing invalid data. The `val` argument to `longjmp()` will be the value apparently returned from the `setjmp()`. This should normally be non-zero, to distinguish it from the genuine `setjmp()` call.

### Example

```
#include <stdio.h>
#include <setjmp.h>
#include <stdlib.h>

jmp_buf jfb;

void
inner (void)
{
    longjmp(jfb, 5);
}

void
main (void)
{
    int i;

    if(i = setjmp(jfb)) {
        printf("setjmp returned %d\n" i);
        exit(0);
    }
    printf("setjmp returned 0 - good\n");
    printf("calling inner...\n");
    inner();
    printf("inner returned - bad!\n");
}
```

### See Also

`setjmp()`

### Return Value

The `longjmp()` routine never returns.

### Note

The function which called `setjmp()` must still be active when `longjmp()` is called. Breach of this rule will cause disaster, due to the use of a stack containing invalid data.

## LTOA

### Synopsis

```
#include <stdlib.h>
```

```
char * ltoa (char * buf, long val, int base)
```

### Description

The function `ltoa` converts the contents of `val` into a string which is stored into `buf`. The conversion is performed according to the radix specified in `base`. `buf` is assumed to reference a buffer which has sufficient space allocated to it.

### Example

```
#include <stdlib.h>
```

```
#include <stdio.h>
```

```
void
```

```
main (void)
```

```
{
```

```
    char buf[10];
```

```
    ltoa(buf, 12345678L, 16);
```

```
    printf("The buffer holds %s\n", buf);
```

```
}
```

### See Also

```
strtol(), itoa(), utoa(), ultoa()
```

### Return Value

This routine returns a copy of the buffer into which the result is written.



## MEMCHR

### Synopsis

```
#include <string.h>
```

```
void * memchr (const void * block, int val, size_t length)
```

### Description

The `memchr()` function is similar to `strchr()` except that instead of searching null-terminated strings, it searches a block of memory specified by length for a particular byte. Its arguments are a pointer to the memory to be searched, the value of the byte to be searched for, and the length of the block. A pointer to the first occurrence of that byte in the block is returned.

### Example

```
#include <string.h>
#include <stdio.h>

unsigned int ary[] = {1, 5, 0x6789, 0x23};

void
main (void)
{
    char * cp;

    cp = memchr(ary, 0x89, sizeof ary);
    if(!cp)
        printf("Not found\n");
    else
        printf("Found at offset %u\n", cp - (char *)ary);
}
```

### See Also

`strchr()`

### Return Value

A pointer to the first byte matching the argument if one exists; `NULL` otherwise.

## MEMCMP

### Synopsis

```
#include <string.h>
```

```
int memcmp (const void * s1, const void * s2, size_t n)
```

### Description

The `memcmp()` function compares two blocks of memory, of length `n`, and returns a signed value similar to `strncmp()`. Unlike `strncmp()` the comparison does not stop on a null character.

### Example

```
#include <stdio.h>
#include <string.h>

void
main (void)
{
    int buf[10], cow[10], i;

    buf[0] = 1;
    buf[2] = 4;
    cow[0] = 1;
    cow[2] = 5;
    buf[1] = 3;
    cow[1] = 3;
    i = memcmp(buf, cow, 3*sizeof(int));
    if(i < 0)
        printf("Less than\n");
    else if(i > 0)
        printf("Greater than\n");
    else
        printf("Equal\n");
}
```

### See Also

`strncmp()`, `strchr()`, `memset()`, `memchr()`

### Return Value

Returns negative one, zero or one, depending on whether `s1` points to string which is less than, equal to or greater than the string pointed to by `s2` in the collating sequence.

## MEMCPY

### Synopsis

```
#include <string.h>
```

```
void * memcpy (void * d, const void * s, size_t n)
```

### Description

The `memcpy()` function copies `n` bytes of memory starting from the location pointed to by `s` to the block of memory pointed to by `d`. The result of copying overlapping blocks is undefined. The `memcpy()` function differs from `strcpy()` in that it copies a specified number of bytes, rather than all bytes up to a null terminator.

### Example

```
#include <string.h>
#include <stdio.h>

void
main (void)
{
    char buf[80];

    memset(buf, 0, sizeof buf);
    memcpy(buf, "A partial string", 10);
    printf("buf = '%s'\n", buf);
}
```

### See Also

`strncpy()`, `strncmp()`, `strchr()`, `memset()`

### Return Value

The `memcpy()` routine returns its first argument.

## MEMMOVE

### Synopsis

```
#include <string.h>
```

```
void * memmove (void * s1, const void * s2, size_t n)
```

### Description

The `memmove()` function is similar to the function `memcpy()` except copying of overlapping blocks is handled correctly. That is, it will copy forwards or backwards as appropriate to correctly copy one block to another that overlaps it.

### See Also

`strncpy()`, `strncmp()`, `strchr()`, `memcpy()`

### Return Value

The function `memmove()` returns its first argument.

## MEMSET

### Synopsis

```
#include <string.h>
```

```
void * memset (void * s, int c, size_t n)
```

### Description

The `memset()` function fills `n` bytes of memory starting at the location pointed to by `s` with the byte `c`.

### Example

```
#include <string.h>
#include <stdio.h>
```

```
void
main (void)
{
    char abuf[20];

    strcpy(abuf, "This is a string");
    memset(abuf, 'x', 5);
    printf("buf = '%s'\n", abuf);
}
```

### See Also

`strncpy()`, `strncmp()`, `strchr()`, `memcpy()`, `memchr()`

## MKTIME

### Synopsis

```
#include <time.h>
```

```
time_t mktime (struct tm * tmptr)
```

### Description

The `mktime()` function converts and returns the local calendar time referenced by the `tm` structure `tmptr` into a time being the number of seconds passed since Jan 1, 1970, or returns -1 if the time cannot be represented.

### Example

```
#include <time.h>
#include <stdio.h>
```

```
void
main (void)
{
    struct tm birthday;

    birthday.tm_year = 83;    // the 5th of May 1983
    birthday.tm_mon = 5;
    birthday.tm_mday = 5;
    birthday.tm_hour = birthday.tm_min = birthday.tm_sec = 0;
    printf("you were born approximately %ld seconds after the
    unix epoch\n",
    mktime(&birthday));
}
```

### See Also

`ctime()`, `asctime()`

### Return Value

The time contained in the `tm` structure represented as the number of seconds since the 1970 Epoch, or -1 if this time cannot be represented.

## MODF

### Synopsis

```
#include <math.h>

double modf (double value, double * iptr)
```

### Description

The `modf()` function splits the argument `value` into integral and fractional parts, each having the same sign as `value`. For example, `-3.17` would be split into the integral part (`-3`) and the fractional part (`-0.17`).

The integral part is stored as a double in the object pointed to by `iptr`.

### Example

```
#include <math.h>
#include <stdio.h>

void
main (void)
{
    double i_val, f_val;

    f_val = modf( -3.17, &i_val);
}

```

### Return Value

The signed fractional part of `value`.

## NOP

### Synopsis

```
#include <xc.h>
```

```
NOP();
```

### Description

Execute `NOP` instruction here. This is often useful to fine tune delays or create a handle for breakpoints. The `NOP` instruction is sometimes required during some sensitive sequences in hardware.

### Example

```
#include <xc.h>

void
crude_delay(unsigned char x) {
    while(x--){
        NOP(); /* Do nothing for 3 cycles */
        NOP();
        NOP();
    }
}

```

## POW

### Synopsis

```
#include <math.h>
```

```
double pow (double f, double p)
```

### Description

The `pow()` function raises its first argument, `f`, to the power `p`.

### Example

```
#include <math.h>
#include <stdio.h>
```

```
void
main (void)
{
    double f;

    for(f = 1.0 ; f <= 10.0 ; f += 1.0)
        printf("pow(2, %1.0f) = %f\n", f, pow(2, f));
}
```

### See Also

`log()`, `log10()`, `exp()`

### Return Value

`f` to the power of `p`.

## PRINTF

### Synopsis

```
#include <stdio.h>

int printf (const char * fmt, ...)
```

### Description

The `printf()` function is a formatted output routine, operating on `stdout`. It relies on the `putch()` function to determine the destination of the standard output stream.

A `putch()` function must be written for each project that uses `printf()`, and the project must include code that initializes any peripherals used by this routine. A stub for `putch()` can be found in the `sources` directory of the compiler, and one possible implementation is shown in the example of this entry. Ensure the source code for your `putch()` added to your project once it is complete.

The `printf()` routine is passed a format string, followed by a list of zero or more arguments. In the format string are conversion specifications, each of which is used to print out one of the argument list values.

Each conversion specification is of the form `%fm.nc`, where the percent symbol `%` introduces a conversion, followed by zero or more flags or modifiers, `f`, (in any order), and followed by an optional width specification `m`. The `n` specification is an optional precision specification (introduced by the dot `.`) and `c` is a letter specifying the type of the conversion, which must appear last in the specification.

Note that the standard default argument promotions are applied to all unprototyped arguments (those appearing after the format string argument, in the case of `printf()`). These promotions consist of the standard integral promotions (see [Section 5.6.1 "Integral Promotion"](#)) and conversion of all `float` values to `double`. Thus, it is not possible to pass any sort of `char`, `short`, or `float` value, for example, to the `printf()` function.

The flags and modifiers may consist of the following.

- A minus sign ('-'), which indicates left rather than right adjustment of the converted value in the field. Where the field width is larger than required for the conversion, blank padding is performed at the left or right as specified.
- A plus sign ('+'), which indicates that the sign of the converted value will always be printed, even if the value is positive.
- A space (' '), which will prefix a space to the converted result if it does not contain a sign (hence this has no effect if the `+` flag is specified) or if a signed conversion results in no characters.
- The digit zero ('0'), which indicates that any padding will be performed with zeros rather than blanks. This flag is ignored if the '-' flag has been specified.
- A hash character ('#'), which indicates that an alternate format is to be used. The nature of the alternate format is discussed below. Not all formats have alternates. In those cases, the presence of the hash character has no effect.
- An elle character ('l'), which indicates that the argument corresponding to a following `d`, `i`, `o`, `u`, `x` or `X` is a `long` or unsigned `long`.

If the character `*` is used in place of a decimal constant for the width or precision, e.g., in the format `%.*d`, then one integer argument will be taken from the list to provide that value.

Note that the `h` and `L` modifiers are not currently supported. Manually cast the argument to a `short` type instead of using the `h` modifier. The MPLAB XC8 `long double` type is equivalent to the `double` type, so the `L` modifier will never have an effect.



The types of conversion are:

**f** Floating point - *m* is the total width and *n* is the number of digits after the decimal point. If *n* is omitted it defaults to 6. If the precision is zero, the decimal point will be omitted unless the alternate format is specified.

**e** Print the corresponding argument in scientific notation. Otherwise similar to **f**.

**g** Use **e** or **f** format, whichever gives maximum precision in minimum width. If the alternate format is not specified, any trailing zeros after the decimal point will be removed, and if no digits remain after the decimal point, it will also be removed.

**o x X u d** Integer conversion - in radices 8, 16, 16, 10 and 10 respectively. The conversion is signed in the case of **d**, unsigned otherwise. The precision value is the total number of digits to print, and can be used to force leading zeros. For example, `%8.4x` will print at least 4 HEX digits in an 8 wide field. Preceding the key letter with an **l** indicates that the value argument is a long integer. The letter **x** prints out hexadecimal numbers using the upper case letters **A-F** rather than **a-f** as would be printed when using **x**. When the alternate format is specified, a leading zero will be supplied for the octal format, and a leading **0x** or **0X** for the HEX format.

**s** Print a string - the value argument is assumed to be a character. At most *n* characters from the string will be printed, in a field *m* characters wide.

**c** The argument is assumed to be a single character and is printed literally.

**p** The argument is assumed to a pointer to an object. The pointer is promoted to a large pointer type, so this placeholder can be used with any pointer size (1, 2 or 3 bytes).

Any other characters used as conversion specifications will be printed. Thus `%%` will produce a single percent sign.

The example shown below can be used to print to the simulator console or a file from within MPLAB X IDE. The code might need modification to suit your target device. Ensure that in your project properties you have turned on the Enable Uart1 IO check box in the Uart1 IO Options option category, in the Simulator category.

## Example

```
#include <xc.h>
#include <stdio.h>
#include <stdarg.h>

long size;

void putch(char data)
{
    while( ! TXIF)
        continue;
    TXREG = data;
}

void init_uart(void)
{
    SPBRG = 0x19;           // 9600 baud @ 4 MHz
    TXEN = 1;              // enable transmitter
    BRGH = 1;              // select high baud rate
    SPEN = 1;              // enable serial port
    CREN = 1;              // enable continuous operation
}

void main(void) {
    init_uart();
    size = 0x12345678;

    printf("Total = %4d%\n", 23);
    printf("Size is %lx\n", size);
    printf("Name = %.8s\n", "a1234567890");
    printf("xx%d\n", 3, 4);

    NOP();

    return;
}
```

will print:

```
Total = 23%
Size is 12345678
Name = a1234567
xx 4
```

## See Also

[sprintf\(\)](#)

## Return Value

The `printf()` function returns the number of characters written to `stdout`.

## PUTCH

### Synopsis

```
#include <conio.h>
```

```
void putch (char c)
```

### Description

The `putch()` function is provided as an empty stub which can be completed as each project requires. It must be defined if you intend to use the `printf()` function. Typically this function will accept one byte of data and send this to a peripheral which is associated with `stdout`.

### Example

```
#include <conio.h>
```

```
char * x = "This is a string";
```

```
void  
main (void)  
{  
    char * cp;  
  
    cp = x;  
    while(*x)  
        putch(*x++);  
    putch('\n');  
}
```

### See Also

`printf()`, `putchar()`

## PUTCHAR

### Synopsis

```
#include <stdio.h>
```

```
int putchar (int c)
```

### Description

The `putchar()` function calls `putch()` to print one character to stdout, and is defined in `stdio.h`.

### Example

```
#include <stdio.h>
```

```
char * x = "This is a string";
```

```
void  
main (void)  
{  
    char * cp;  
  
    cp = x;  
    while(*x)  
        putchar(*x++);  
    putchar('\n');  
}
```

### See Also

`putc()`, `getc()`, `freopen()`, `fclose()`

### Return Value

The character passed as argument, or EOF if an error occurred.

## PUTS

### Synopsis

```
#include <stdio.h>
```

```
int puts (const char * s)
```

### Description

The `puts()` function writes the string `s` to the `stdout` stream, appending a newline. The null character terminating the string is not copied.

### Example

```
#include <stdio.h>
```

```
void  
main (void)  
{  
    puts("Hello, world!");  
}
```

### See Also

`fputs()`, `gets()`, `freopen()`, `fclose()`

### Return Value

EOF is returned on error; zero otherwise.

## QSORT

### Synopsis

```
#include <stdlib.h>
```

```
void qsort (void * base, size_t nel, size_t width,  
int (*func)(const void *, const void *))
```

### Description

The `qsort()` function is an implementation of the quicksort algorithm. It sorts an array of `nel` items, each of length `width` bytes, located contiguously in memory at `base`. The argument `func` is a pointer to a function used by `qsort()` to compare items. It calls `func` with `s` to two items to be compared. If the first item is considered to be greater than, equal to or less than the second then `func` should return a value greater than zero, equal to zero or less than zero respectively.

### Example

```
#include <stdio.h>  
#include <stdlib.h>  
  
int array[] = {  
    567, 23, 456, 1024, 17, 567, 66  
};  
  
int  
sortem (const void * p1, const void * p2)  
{  
    return *(int *)p1 - *(int *)p2;  
}  
  
void  
main (void)  
{  
    register int i;  
  
    qsort(array, sizeof array/sizeof array[0],  
        sizeof array[0], sortem);  
    for(i = 0 ; i != sizeof array/sizeof array[0] ; i++)  
        printf("%d\t", array[i]);  
    putchar('\n');  
}
```

### Note

The function parameter must be a pointer to a function of type similar to:

```
int func (const void *, const void *)
```

For example, it must accept two `const void *` parameters, and must be prototyped.

## RAND

### Synopsis

```
#include <stdlib.h>
```

```
int rand (void)
```

### Description

The `rand()` function is a pseudo-random number generator. It returns an integer in the range 0 to 32767, which changes in a pseudo-random fashion on each call. The algorithm will produce a deterministic sequence if started from the same point. The starting point is set using the `srand()` call. The example shows use of the `time()` function to generate a different starting point for the sequence each time.

### Example

```
#include <stdlib.h>
#include <stdio.h>
#include <time.h>

void
main (void)
{
    time_t toc;
    int i;

    time(&toc);
    srand((int)toc);
    for(i = 0 ; i != 10 ; i++)
        printf("%d\t", rand());
    putchar('\n');
}
```

### See Also

`srand()`

### Note

The example will require the user to provide the `time()` routine as one cannot be supplied with the compiler. See `time()` for more detail.

## READTIMERx

### Synopsis

```
#include <xc.h>
unsigned short READTIMERx (void);
```

### Description

The `READTIMERx()` macro returns the value held by the `TMRx` register, where `x` is one of the digits 0, 1 or 3.

### Example

```
#include <xc>

void
main (void)
{
    while (READTIMER0 () != 0xFF)

        continue;

    SLEEP ();
}
```

### See Also

`WRITETIMERx()`

### Return Value

The value held by the `TMRx` register.

### Note

This macro can only be used with PIC18 devices.

## RESET

### Synopsis

```
#include <xc.h>
```

```
RESET();
```

### Description

Execute a `RESET` instruction here. This will trigger a software device Reset.

### Example

```
#include <xc.h>

void
main(void)
{
    init();
    while( ! (fail_code = getStatus())) {
        process();
    }
    if(fail_code > 2) // something's serious wrong
        RESET(); // reset the whole device
    // otherwise try restart code from main()
}
```



## ROUND

### Synopsis

```
#include <math.h>

double round (double x)
```

### Description

The `round` function round the argument to the nearest integer value, but in floating-point format. Values midway between integer values are rounded up.

### Example

```
#include <math.h>

void
main (void)
{
    double input, rounded;
    input = 1234.5678;
    rounded = round(input);
}
```

### See Also

`trunc()`

## SETJMP

### Synopsis

```
#include <setjmp.h>

int setjmp (jmp_buf buf)
```

### Description

The `setjmp()` function is used with `longjmp()` for non-local goto's. See `longjmp()` for further information.

### Example

```
#include <stdio.h>
#include <setjmp.h>
#include <stdlib.h>

jmp_buf jb;

void
inner (void)
{
    longjmp(jb, 5);
}

void
main (void)
{
    int i;

    if(i = setjmp(jb)) {
        printf("setjmp returned %d\n", i);
        exit(0);
    }
    printf("setjmp returned 0 - good\n");
    printf("calling inner...\n");
    inner();
    printf("inner returned - bad!\n");
}
```

### See Also

`longjmp()`

### Return Value

The `setjmp()` function returns zero after the real call, and non-zero if it apparently returns after a call to `longjmp()`.

## SIN

### Synopsis

```
#include <math.h>
```

```
double sin (double f)
```

### Description

This function returns the sine function of its argument.

### Example

```
#include <math.h>
#include <stdio.h>

#define C 3.141592/180.0

void
main (void)
{
    double i;

    for(i = 0 ; i <= 180.0 ; i += 10)
        printf("sin(%3.0f) = %f\n", i, sin(i*C));
        printf("cos(%3.0f) = %f\n", i, cos(i*C));
}
```

### See Also

`cos()`, `tan()`, `asin()`, `acos()`, `atan()`, `atan2()`

### Return Value

Sine value of *f*.

## SLEEP

### Synopsis

```
#include <xc.h>
```

```
SLEEP();
```

### Description

This macro is used to put the device into a low-power standby mode.

### Example

```
#include <xc.h>
extern void init(void);

void
main (void)
{
    init(); /* enable peripherals/interrupts */

    while(1)
        SLEEP(); /* save power while nothing happening */
}
```

## SPRINTF

### Synopsis

```
#include <stdio.h>
```

```
int sprintf (char * buf, const char * fmt, ...)
```

### Description

The `sprintf()` function operates in a similar fashion to `printf()`, except that instead of placing the converted output on the `stdout` stream, the characters are placed in the buffer at `buf`. The resultant string will be null terminated, and the number of characters in the buffer will be returned.

### See Also

`printf()`

### Return Value

This routine return the number of characters placed into the buffer.

## SQRT

### Synopsis

```
#include <math.h>
```

```
double sqrt (double f)
```

### Description

The function `sqrt()`, implements a square root routine using Newton's approximation.

### Example

```
#include <math.h>
#include <stdio.h>

void
main (void)
{
    double i;

    for(i = 0 ; i <= 20.0 ; i += 1.0)
        printf("square root of %.1f = %f\n", i, sqrt(i));
}
```

### See Also

`exp()`

### Return Value

Returns the value of the square root.

### Note

A domain error occurs if the argument is negative and `errno` will be set to `EDOM`.

## SRAND

### Synopsis

```
#include <stdlib.h>

void srand (unsigned int seed)
```

### Description

The `srand()` function initializes the random number generator accessed by `rand()` with the given `seed`. This provides a mechanism for varying the starting point of the pseudo-random sequence yielded by `rand()`.

### Example

```
#include <stdlib.h>
#include <stdio.h>
#include <time.h>

void
main (void)
{
    time_t toc;
    int i;

    time(&toc);
    srand((int)toc);
    for(i = 0 ; i != 10 ; i++)
        printf("%d\t", rand());
    putchar('\n');
}
```

### See Also

`rand()`

## STRCAT

### Synopsis

```
#include <string.h>
```

```
char * strcat (char * s1, const char * s2)
```

### Description

This function appends (concatenates) string `s2` to the end of string `s1`. The result will be null terminated. The argument `s1` must point to a character array big enough to hold the resultant string.

### Example

```
#include <string.h>
```

```
#include <stdio.h>
```

```
void  
main (void)  
{  
    char buffer[256];  
    char * s1, * s2;  
  
    strcpy(buffer, "Start of line");  
    s1 = buffer;  
    s2 = "... end of line";  
    strcat(s1, s2);  
    printf("Length = %d\n", strlen(buffer));  
    printf("string = \"%s\"\n", buffer);  
}
```

### See Also

`strcpy()`, `strcmp()`, `strncat()`, `strlen()`

### Return Value

The value of `s1` is returned.

## STRCHR, STRICHR

### Synopsis

```
#include <string.h>
```

```
char * strchr (const char * s, int c)  
char * strichr (const char * s, int c)
```

### Description

The `strchr()` function searches the string `s` for an occurrence of the character `c`. If one is found, a pointer to that character is returned, otherwise null is returned.

The `strichr()` function is the case-insensitive version of this function.

### Example

```
#include <strings.h>  
#include <stdio.h>  
  
void  
main (void)  
{  
    static char temp[] = "Here it is...";  
    char c = 's';  
  
    if(strchr(temp, c))  
        printf("Character %c was found in string\n", c);  
    else  
        printf("No character was found in string");  
}
```

### See Also

`strrchr()`, `strlen()`, `strcmp()`

### Return Value

A pointer to the first match found, or `NULL` if the character does not exist in the string.

### Note

Although the function takes an integer argument for the character, only the lower 8 bits of the value are used.



## STRCMP, STRICMP

### Synopsis

```
#include <string.h>

int strcmp (const char * s1, const char * s2)
int stricmp (const char * s1, const char * s2)
```

### Description

The `strcmp()` function compares its two, null terminated, string arguments and returns a signed integer to indicate whether `s1` is less than, equal to or greater than `s2`. The comparison is done with the standard collating sequence, which is that of the ASCII character set.

The `stricmp()` function is the case-insensitive version of this function.

### Example

```
#include <string.h>
#include <stdio.h>

void
main (void)
{
    int i;

    if((i = strcmp("ABC", "ABc")) < 0)
        printf("ABC is less than ABc\n");
    else if(i > 0)
        printf("ABC is greater than ABc\n");
    else
        printf("ABC is equal to ABc\n");
}
```

### See Also

`strlen()`, `strncmp()`, `strcpy()`, `strcat()`

### Return Value

A signed integer less than, equal to or greater than zero.

### Note

Other C implementations can use a different collating sequence; the return value is negative, zero, or positive; i.e., do not test explicitly for negative one (-1) or one (1).

## STRCPY

### Synopsis

```
#include <string.h>
```

```
char * strcpy (char * s1, const char * s2)
```

### Description

This function copies a null terminated string *s2* to a character array pointed to by *s1*. The destination array must be large enough to hold the entire string, including the null terminator.

### Example

```
#include <string.h>
```

```
#include <stdio.h>
```

```
void
```

```
main (void)
```

```
{
```

```
    char buffer[256];
```

```
    char * s1, * s2;
```

```
    strcpy(buffer, "Start of line");
```

```
    s1 = buffer;
```

```
    s2 = "... end of line";
```

```
    strcat(s1, s2);
```

```
    printf("Length = %d\n", strlen(buffer));
```

```
    printf("string = \"%s\"\n", buffer);
```

```
}
```

### See Also

`strncpy()`, `strlen()`, `strcat()`, `strlen()`

### Return Value

The destination buffer *s1* is returned.

## STRCSPN

### Synopsis

```
#include <string.h>
```

```
size_t strcspn (const char * s1, const char * s2)
```

### Description

The `strcspn()` function returns the length of the initial segment of the string pointed to by `s1` which consists of characters NOT from the string pointed to by `s2`.

### Example

```
#include <stdio.h>
#include <string.h>
```

```
void
main (void)
{
    static char set[] = "xyz";

    printf("%d\n", strcspn("abcdevwxyz", set));
    printf("%d\n", strcspn("xxxbcadefs", set));
    printf("%d\n", strcspn("1234567890", set));
}
```

### See Also

`strspn()`

### Return Value

Returns the length of the segment.

## STRLEN

### Synopsis

```
#include <string.h>

size_t strlen (const char * s)
```

### Description

The `strlen()` function returns the number of characters in the string `s`, not including the null terminator.

### Example

```
#include <string.h>
#include <stdio.h>

void
main (void)
{
    char buffer[256];
    char * s1, * s2;

    strcpy(buffer, "Start of line");
    s1 = buffer;
    s2 = "... end of line";
    strcat(s1, s2);
    printf("Length = %d\n", strlen(buffer));
    printf("string = \"%s\"\n", buffer);
}
```

### Return Value

The number of characters preceding the null terminator.

## STRNCAT

### Synopsis

```
#include <string.h>
```

```
char * strncat (char * s1, const char * s2, size_t n)
```

### Description

This function appends (concatenates) string `s2` to the end of string `s1`. At most `n` characters will be copied, and the result will be null terminated. `s1` must point to a character array big enough to hold the resultant string.

### Example

```
#include <string.h>
```

```
#include <stdio.h>
```

```
void  
main (void)  
{  
    char buffer[256];  
    char * s1, * s2;  
  
    strcpy(buffer, "Start of line");  
    s1 = buffer;  
    s2 = "... end of line";  
    strncat(s1, s2, 5);  
    printf("Length = %d\n", strlen(buffer));  
    printf("string = \"%s\"\n", buffer);  
}
```

### See Also

`strcpy()`, `strcmp()`, `strcat()`, `strlen()`

### Return Value

The value of `s1` is returned.

## STRNCMP, STRNICMP

### Synopsis

```
#include <string.h>
```

```
int strcmp (const char * s1, const char * s2, size_t n)
int strnicmp (const char * s1, const char * s2, size_t n)
```

### Description

The `strcmp()` function compares its two, null terminated, string arguments, up to a maximum of `n` characters, and returns a signed integer to indicate whether `s1` is less than, equal to or greater than `s2`. The comparison is done with the standard collating sequence, which is that of the ASCII character set.

The `strnicmp()` function is the case-insensitive version of this function.

### Example

```
#include <stdio.h>
#include <string.h>

void
main (void)
{
    int i;

    i = strcmp("abcxyz", "abcxyz", 6);
    if(i == 0)
        printf("The strings are equal\n");
    else if(i > 0)
        printf("String 2 less than string 1\n");
    else
        printf("String 2 is greater than string 1\n");
}
```

### See Also

`strlen()`, `strcmp()`, `strcpy()`, `strcat()`

### Return Value

A signed integer less than, equal to or greater than zero.

### Note

Other C implementations can use a different collating sequence; the return value is negative, zero, or positive; i.e., do not test explicitly for negative one (-1) or one (1).

## STRNCPY

### Synopsis

```
#include <string.h>
```

```
char * strncpy (char * s1, const char * s2, size_t n)
```

### Description

This function copies a null terminated string `s2` to a character array pointed to by `s1`. At most, `n` characters are copied, but `n` characters are *always* written. If string `s2` is longer than `n`, then the destination string will not be null terminated. If string `s2` is shorter than `n`, then the remaining bytes of the destination array are filled with `'\0'`. It is up to the programmer to ensure that the destination array is large enough to hold the entire string, including the null terminator.

### Example

```
#include <string.h>
#include <stdio.h>

void
main (void)
{
    char buffer[256];
    char * s1, * s2;

    strncpy(buffer, "Start of line", 6);
    s1 = buffer;
    s2 = "... end of line";
    strcat(s1, s2);
    printf("Length = %d\n", strlen(buffer));
    printf("string = \"%s\"\n", buffer);
}
```

### See Also

`strcpy()`, `strcat()`, `strlen()`, `strcmp()`

### Return Value

The destination buffer `s1` is returned.

### Note

This function always writes `n` characters to the destination array. Ensure that this operation is what you require in your program. The copied string will not be null terminated if the destination is not large enough to hold the source string.

## STRPBRK

### Synopsis

```
#include <string.h>
```

```
char * strpbrk (const char * s1, const char * s2)
```

### Description

The `strpbrk()` function returns a pointer to the first occurrence in string `s1` of any character from string `s2`, or a null if no character from `s2` exists in `s1`.

### Example

```
#include <stdio.h>
#include <string.h>
```

```
void
main (void)
{
    char * str = "This is a string.";

    while(str != NULL) {
        printf("%s\n", str);
        str = strpbrk(str+1, "aeiou");
    }
}
```

### Return Value

to the first matching character, or `NULL` if no character found.



## STRCHR, STRRCHR

### Synopsis

```
#include <string.h>
```

```
char * strrchr (char * s, int c)  
char * strrichr (char * s, int c)
```

### Description

The `strrchr()` function is similar to the `strchr()` function, but searches from the end of the string rather than the beginning; i.e., it locates the *last* occurrence of the character `c` in the null terminated string `s`. If successful it returns a pointer to that occurrence, otherwise it returns `NULL`.

The `strrichr()` function is the case-insensitive version of this function.

### Example

```
#include <stdio.h>  
#include <string.h>  
  
void  
main (void)  
{  
    char * str = "This is a string."  
  
    while(str != NULL) {  
        printf("%s\n", str);  
        str = strrchr(str+1, 's');  
    }  
}
```

### See Also

`strchr()`, `strlen()`, `strcmp()`, `strcpy()`, `strcat()`

### Return Value

A pointer to the character, or `NULL` if none is found.

## STRSPN

### Synopsis

```
#include <string.h>
```

```
size_t strspn (const char * s1, const char * s2)
```

### Description

The `strspn()` function returns the length of the initial segment of the string pointed to by `s1` which consists entirely of characters from the string pointed to by `s2`.

### Example

```
#include <stdio.h>
#include <string.h>
```

```
void
main (void)
{
    printf("%d\n", strspn("This is a string", "This"));
    printf("%d\n", strspn("This is a string", "this"));
}
```

### See Also

`strcspn()`

### Return Value

The length of the segment.

## STRSTR, STRISTR

### Synopsis

```
#include <string.h>
```

```
char * strstr (const char * s1, const char * s2)
char * stristr (const char * s1, const char * s2)
```

### Description

The `strstr()` function locates the first occurrence of the sequence of characters in the string pointed to by `s2` in the string pointed to by `s1`.

The `stristr()` routine is the case-insensitive version of this function.

### Example

```
#include <stdio.h>
#include <string.h>
```

```
void
main (void)
{
    printf("%d\n", strstr("This is a string", "str"));
}
```

### Return Value

to the located string or a null if the string was not found.

## STRTOD

### Synopsis

```
#include <stdlib.h>
```

```
double strtod (const char * s, const char ** res)
```

### Description

Parse the string *s* converting it to a double floating-point type. This function converts the first occurrence of a substring of the input that is made up of characters of the expected form after skipping leading white-space characters. If *res* is not `NULL`, it will be made to point to the first character after the converted sub-string.

### Example

```
#include <stdio.h>
#include <strlib.h>
```

```
void
main (void)
{
    char buf[] = "35.7 23.27";
    char * end;
    double in1, in2;

    in1 = strtod(buf, &end);
    in2 = strtod(end, NULL);
    printf("in comps: %f, %f\n", in1, in2);
}
```

### See Also

`atof()`

### Return Value

Returns a double representing the floating-point value of the converted input string.

## STRTOL

### Synopsis

```
#include <stdlib.h>
```

```
double strtol (const char * s, const char ** res, int base)
```

### Description

Parse the string *s* converting it to a long integer type. This function converts the first occurrence of a substring of the input that is made up of characters of the expected form after skipping leading white-space characters. The radix of the input is determined from *base*. If this is zero, then the radix defaults to base 10. If *res* is not `NULL`, it will be made to point to the first character after the converted sub-string.

### Example

```
#include <stdio.h>
#include <strlib.h>

void
main (void)
{
    char buf[] = "0X299 0x792";
    char * end;
    long in1, in2;

    in1 = strtol(buf, &end, 16);
    in2 = strtol(end, NULL, 16);
    printf("in (decimal): %ld, %ld\n", in1, in2);
}
```

### See Also

`strtod()`

### Return Value

Returns a long int representing the value of the converted input string using the specified base.

## STRTOK

### Synopsis

```
#include <string.h>
```

```
char * strtok (char * s1, const char * s2)
```

### Description

A number of calls to `strtok()` breaks the string `s1` (which consists of a sequence of zero or more text tokens separated by one or more characters from the separator string `s2`) into its separate tokens.

The first call must have the string `s1`. This call returns a pointer to the first character of the first token, or `NULL` if no tokens were found. The inter-token separator character is overwritten by a null character, which terminates the current token.

For subsequent calls to `strtok()`, `s1` should be set to a `NULL`. These calls start searching from the end of the last token found, and again return a pointer to the first character of the next token, or `NULL` if no further tokens were found.

### Example

```
#include <stdio.h>
#include <string.h>

void
main (void)
{
    char * ptr;
    char buf[] = "This is a string of words.";
    char * sep_tok = ",?! ";

    ptr = strtok(buf, sep_tok);
    while(ptr != NULL) {
        printf("%s\n", ptr);
        ptr = strtok(NULL, sep_tok);
    }
}
```

### Return Value

Returns a pointer to the first character of a token, or a null if no token was found.

### Note

The separator string `s2` can be different from call to call.

## TAN

### Synopsis

```
#include <math.h>
```

```
double tan (double f)
```

### Description

The `tan()` function calculates the tangent of  $f$ .

### Example

```
#include <math.h>
#include <stdio.h>

#define C 3.141592/180.0

void
main (void)
{
    double i;

    for(i = 0 ; i <= 180.0 ; i += 10)
        printf("tan(%3.0f) = %f\n", i, tan(i*C));
}
```

### See Also

`sin()`, `cos()`, `asin()`, `acos()`, `atan()`, `atan2()`

### Return Value

The tangent of  $f$ .

## TIME

### Synopsis

```
#include <time.h>

time_t time (time_t * t)
```

### Description

This function is not provided as it is dependent on the target system supplying the current time. This function will be user implemented. When implemented, this function should return the current time in seconds since 00:00:00 on Jan 1, 1970. If the argument `t` is not equal to `NULL`, the same value is stored into the object pointed to by `t`.

### Example

```
#include <stdio.h>
#include <time.h>

void
main (void)
{
    time_t clock;

    time(&clock);
    printf("%s", ctime(&clock));
}
```

### See Also

`ctime()`, `gmtime()`, `localtime()`, `asctime()`

### Return Value

This routine, when implemented, will return the current time (in seconds) since 00:00:00 on Jan 1, 1970.

### Note

The `time()` routine is not supplied, if required the user will have to implement this routine to the specifications outlined above.

## TOLOWER, TOUPPER, TOASCII

### Synopsis

```
#include <ctype.h>

char toupper (int c)
char tolower (int c)
char toascii (int c)
```

### Description

The `toupper()` function converts its lower case alphabetic argument to upper case, the `tolower()` routine performs the reverse conversion and the `toascii()` macro returns a result that is guaranteed in the range 0-0177. The functions `toupper()` and `tolower()` return their arguments if it is not an alphabetic character.

### Example

```
#include <stdio.h>
#include <ctype.h>
#include <string.h>

void
main (void)
{
    char * array1 = "aBcDE";
    int i;

    for(i=0;i < strlen(array1); ++i) {
        printf("%c", tolower(array1[i]));
    }
    printf("\n");
}
```

### See Also

`islower()`, `isupper()`, `isascii()`, et. al.



## TRUNC

### Synopsis

```
#include <math.h>

double trunc (double x)
```

### Description

The `trunc` function rounds the argument to the nearest integer value, in floating-point format, that is not larger in magnitude than the argument.

### Example

```
#include <math.h>

void
main (void)
{
    double input, rounded;
    input = 1234.5678;
    rounded = trunc(input);
}
```

### See Also

`round()`

## UDIV

### Synopsis

```
#include <stdlib.h>

int udiv (unsigned num, unsigned denom)
```

### Description

The `udiv()` function calculate the quotient and remainder of the division of `number` and `denom`, storing the results into a `udiv_t` structure which is returned.

### Example

```
#include <stdlib.h>

void
main (void)
{
    udiv_t result;
    unsigned num = 1234, den = 7;

    result = udiv(num, den);
}
```

### See Also

`uldiv()`, `div()`, `ldiv()`

### Return Value

Returns the quotient and remainder as a `udiv_t` structure.

## ULDIV

### Synopsis

```
#include <stdlib.h>
```

```
int uldiv (unsigned long num, unsigned long denom)
```

### Description

The `uldiv()` function calculate the quotient and remainder of the division of `number` and `denom`, storing the results into a `uldiv_t` structure which is returned.

### Example

```
#include <stdlib.h>
```

```
void  
main (void)  
{  
    uldiv_t result;  
    unsigned long num = 1234, den = 7;  
  
    result = uldiv(num, den);  
}
```

### See Also

`ldiv()`, `udiv()`, `div()`

### Return Value

Returns the quotient and remainder as a `uldiv_t` structure.

## UTOA

### Synopsis

```
#include <stdlib.h>
```

```
char * utoa (char * buf, unsigned val, int base)
```

### Description

The function `utoa()` converts the unsigned contents of `val` into a string which is stored into `buf`. The conversion is performed according to the radix specified in `base`. `buf` is assumed to reference a buffer which has sufficient space allocated to it.

### Example

```
#include <stdlib.h>
```

```
#include <stdio.h>
```

```
void  
main (void)  
{  
    char buf[10];  
    utoa(buf, 1234, 16);  
    printf("The buffer holds %s\n", buf);  
}
```

### See Also

```
strtol(), itoa(), ltoa(), ultoa()
```

### Return Value

This routine returns a copy of the buffer into which the result is written.

## VA\_START, VA\_ARG, VA\_END

### Synopsis

```
#include <stdarg.h>

void va_start (va_list ap, parmN)
type va_arg (ap, type)
void va_end (va_list ap)
```

### Description

These macros are provided to give access in a portable way to parameters to a function represented in a prototype by the ellipsis symbol (. . .), where type and number of arguments supplied to the function are not known at compile time.

The right most parameter to the function (shown as *parmN*) plays an important role in these macros, as it is the starting point for access to further parameters. In a function taking variable numbers of arguments, a variable of type *va\_list* should be declared, then the macro *va\_start()* invoked with that variable and the name of *parmN*. This will initialize the variable to allow subsequent calls of the macro *va\_arg()* to access successive parameters.

Each call to *va\_arg()* requires two arguments; the variable previously defined and a type name which is the type that the next parameter is expected to be. Note that any arguments thus accessed will have been widened by the default conventions to *int*, *unsigned int* or *double*. For example, if a character argument has been passed, it should be accessed by *va\_arg(ap, int)* since the *char* will have been widened to *int*.

An example is given below of a function taking one integer parameter, followed by a number of other parameters. In this example the function expects the subsequent parameters to be *s* to *char*, but note that the compiler is not aware of this, and it is the programmers responsibility to ensure that correct arguments are supplied.

### Example

```
#include <stdio.h>
#include <stdarg.h>

void
pf (int a, ...)
{
    va_list ap;

    va_start(ap, a);
    while(a--)
        puts(va_arg(ap, char *));
    va_end(ap);
}

void
main (void)
{
    pf(3, "Line 1", "Line 2", "Line 3");
}
```

## WRITETIMERx

### Synopsis

```
#include <xc.h>
void WRITETIMERx (int n);
```

### Description

The `WRITETIMERx()` macro writes the 16-bit argument, `n`, to both bytes of the `TMRx` register, where `x` is one of the digits 0, 1 or 3.

### Example

```
#include <xc.h>
void
main (void)
{
    WRITETIMER1 (0x4A);

    while (1)

        continue;
}
```

### See Also

`READTIMERx()`

### Note

This macro can only be used with PIC18 devices.

## XTOI

### Synopsis

```
#include <stdlib.h>

unsigned xtoi (const char * s)
```

### Description

The `xtoi()` function scans the character string passed to it, skipping leading blanks reading an optional sign, and converts an ASCII representation of a hexadecimal number to an integer.

### Example

```
#include <stdlib.h>
#include <stdio.h>

void
main (void)
{
    char buf[80];
    int i;

    gets (buf);
    i = xtoi (buf);
    printf("Read %s: converted to %x\n", buf, i);
}
```

### See Also

`atoi()`

### Return Value

An unsigned integer. If no number is found in the string, zero will be returned.

## Appendix B. Embedded Compiler Compatibility Mode

### B.1 INTRODUCTION

All three MPLAB XC C compilers can be placed into a compatibility mode. In this mode, they are syntactically compatible with the non-standard C language extensions used by other non-Microchip embedded compiler vendors. This compatibility allows C source code written for other compilers to be compiled with minimum modification when using the MPLAB XC compilers.

Since very different device architectures can be targeted by other compilers, the semantics of the non-standard extensions can be different to that in the MPLAB XC compilers. This document indicates when the original C code can need to be reviewed.

The compatibility features offered by the MPLAB C compilers are discussed in the following topics:

- [Compiling in Compatibility Mode](#)
- [Syntax Compatibility](#)
- [Data Type](#)
- [Operator](#)
- [Extended Keywords](#)
- [All assembly code specified by this construct is device-specific and will need review when porting to any Microchip device.](#)
- [Pragmas](#)

### B.2 COMPILING IN COMPATIBILITY MODE

An option is used to enable vendor-specific syntax compatibility. When using MPLAB XC8, this option is `--ext=vendor`; when using MPLAB XC16 or MPLAB XC32, the option is `-mext=vendor`. The argument *vendor* is a key that is used to represent the syntax. See [Table B-1](#) for a list of all keys usable with the MPLAB XC compilers.

**TABLE B-1: VENDOR KEYS**

Vendor key	Syntax	XC8 Support	XC16 Support	XC32 Support
<code>cci</code>	Common C Interface	Yes	Yes	Yes
<code>iar</code>	IAR C/C++ Compiler™ for ARM	Yes	Yes	Yes

The Common C Interface (CCI) is a language standard that is common to all Microchip MPLAB XC compilers. The non-standard extensions associated with this syntax are already described in [Chapter 2. Common C Interface](#) and are not repeated here.

## B.3 SYNTAX COMPATIBILITY

The goal of this syntax compatibility feature is to ease the migration process when porting source code from other C compilers to the native MPLAB XC compiler syntax.

Many non-standard extensions are not required when compiling for Microchip devices and, for these, there are no equivalent extensions offered by MPLAB XC compilers. These extensions are then simply ignored by the MPLAB XC compilers, although a warning message is usually produced to ensure you are aware of the different compiler behavior. You should confirm that your project will still operate correctly with these features disabled.

Other non-standard extensions are not compatible with Microchip devices. Errors will be generated by the MPLAB XC compiler if these extensions are not removed from the source code. You should review the ramifications of removing the extension and decide whether changes are required to other source code in your project.

[Table B-2](#) indicates the various levels of compatibility used in the tables that are presented throughout this guide.

**TABLE B-2: LEVEL OF SUPPORT INDICATORS**

Level	Explanation
support	The syntax is accepted in the specified compatibility mode, and its meaning will mimic its meaning when it is used with the original compiler.
support (no args)	In the case of pragmas, the base pragma is supported in the specified compatibility mode, but the arguments are ignored.
native support	The syntax is equivalent to that which is already accepted by the MPLAB XC compiler, and the semantics are compatible. You can use this feature without a vendor compatibility mode having been enabled.
ignore	The syntax is accepted in the specified compatibility mode, but the implied action is not required or performed. The extension is ignored and a warning will be issued by the compiler.
error	The syntax is not accepted in the specified compatibility mode. An error will be issued and compilation will be terminated.

Note that even if a C feature is supported by an MPLAB XC compiler, addresses, register names, assembly instructions, or any other device-specific argument is unlikely to be valid when compiling for a Microchip device. Always review code which uses these items in conjunction with the data sheet of your target Microchip device.



# Embedded Compiler Compatibility Mode

## B.4 DATA TYPE

Some compilers allow use of the boolean type, `bool`, as well as associated values `true` and `false`, as specified by the C99 ANSI Standard. This type and these values can be used by all MPLAB XC compilers when in compatibility mode<sup>1</sup>, as shown in [Table B-3](#).

As indicated by the ANSI Standard, the `<stdbool.h>` header must be included for this feature to work as expected when it is used with MPLAB XC compilers.

**TABLE B-3: SUPPORT FOR C99 BOOL TYPE**

IAR Compatibility Mode			
Type	MPLAB XC8	MPLAB XC16	MPLAB XC32
<code>bool</code>	support	support	support

Do not confuse the boolean type, `bool`, and the integer type, `bit`, implemented by MPLAB XC8.

## B.5 OPERATOR

The `@` operator can be used with other compilers to indicate the desired memory location of an object. As [Table B-4](#) indicates, support for this syntax in MPLAB C is limited to MPLAB XC8 only.

Any address specified with another device is unlikely to be correct on a new architecture. Review the address in conjunction with the data sheet for your target Microchip device.

Using `@` in a compatibility mode with MPLAB XC8 will work correctly, but will generate a warning. To prevent this warning from appearing again, use the reviewed address with the MPLAB C `__at()` specifier instead.

For MPLAB XC16 and XC32, consider using the `address` attribute.

**TABLE B-4: SUPPORT FOR NON-STANDARD OPERATOR**

IAR Compatibility Mode			
Operator	MPLAB XC8	MPLAB XC16	MPLAB XC32
<code>@</code>	native support	error	error

1. Not all C99 features have been adopted by all Microchip MPLAB XC compilers.

## B.6 EXTENDED KEYWORDS

Non-standard extensions often specify how objects are defined or accessed. Keywords are usually used to indicate the feature. The non-standard C keywords corresponding to other compilers are listed in [Table B-5](#), as well as the level of compatibility offered by MPLAB XC compilers. The table notes offer more information about some extensions.

**TABLE B-5: SUPPORT FOR NON-STANDARD KEYWORDS**

Keyword	IAR Compatibility Mode		
	MPLAB XC8	MPLAB XC16	MPLAB XC32
<code>__section_begin</code>	ignore	support	support
<code>__section_end</code>	ignore	support	support
<code>__section_size</code>	ignore	support	support
<code>__segment_begin</code>	ignore	support	support
<code>__segment_end</code>	ignore	support	support
<code>__segment_size</code>	ignore	support	support
<code>__sfb</code>	ignore	support	support
<code>__sfe</code>	ignore	support	support
<code>__sfs</code>	ignore	support	support
<code>__asm</code> or <code>asm</code> <sup>(1)</sup>	support <sup>(2)</sup>	native support	native support
<code>__arm</code>	ignore	ignore	ignore
<code>__big_endian</code>	error	error	error
<code>__fiq</code>	support	error	error
<code>__intrinsic</code>	ignore	ignore	ignore
<code>__interwork</code>	ignore	ignore	ignore
<code>__irq</code>	support	error	error
<code>__little_endian</code> <sup>(3)</sup>	ignore	ignore	ignore
<code>__nested</code>	ignore	ignore	ignore
<code>__no_init</code>	support	support	support
<code>__noreturn</code>	ignore	support	support
<code>__ramfunc</code>	ignore	ignore	support <sup>(4)</sup>
<code>__packed</code>	ignore <sup>(5)</sup>	support	support
<code>__root</code>	ignore	support	support
<code>__swi</code>	ignore	ignore	ignore
<code>__task</code>	ignore	support	support
<code>__weak</code>	ignore	support	support
<code>__thumb</code>	ignore	ignore	ignore
<code>__farfunc</code>	ignore	ignore	ignore
<code>__huge</code>	ignore	ignore	ignore
<code>__nearfunc</code>	ignore	ignore	ignore
<code>__inline</code>	support	native support	native support

**Note 1:** All assembly code specified by this construct is device-specific and will need review when porting to any Microchip device.

**2:** The keyword, `asm`, is supported natively by MPLAB XC8, but this compiler only supports the `__asm` keyword in IAR compatibility mode.

**3:** This is the default (and only) endianness used by all MPLAB XC compilers.

**4:** When used with MPLAB XC32, this must be used with the `__longcall__` macro for full compatibility.

**5:** Although this keyword is ignored, by default, all structures are packed when using MPLAB XC8, so there is no loss of functionality.

# Embedded Compiler Compatibility Mode

## B.7 INTRINSIC FUNCTIONS

Intrinsic functions can be used to perform common tasks in the source code. The MPLAB XC compilers' support for the intrinsic functions offered by other compilers is shown in [Table B-6](#).

**TABLE B-6: SUPPORT FOR NON-STANDARD INTRINSIC FUNCTIONS**

IAR Compatibility Mode			
Function	MPLAB XC8	MPLAB XC16	MPLAB XC32
<code>__disable_fiq<sup>1</sup></code>	support	ignore	ignore
<code>__disable_interrupt</code>	support	support	support
<code>__disable_irq<sup>1</sup></code>	support	ignore	ignore
<code>__enable_fiq<sup>1</sup></code>	support	ignore	ignore
<code>__enable_interrupt</code>	support	support	support
<code>__enable_irq<sup>1</sup></code>	support	ignore	ignore
<code>__get_interrupt_state</code>	ignore	support	support
<code>__set_interrupt_state</code>	ignore	support	support

**Note 1:** These intrinsic functions map to macros which disable or enable the global interrupt enable bit on 8-bit PIC<sup>®</sup> devices.

The header file `<xc.h>` must be included for supported functions to operate correctly.

# MPLAB® XC8 C Compiler User's Guide

## B.8 PRAGMAS

Pragmas can be used by a compiler to control code generation. Any compiler will ignore an unknown pragma, but many pragmas implemented by another compiler have also been implemented by the MPLAB XC compilers in compatibility mode. [Table B-7](#) shows the pragmas and the level of support when using each of the MPLAB XC compilers.

Many of these pragmas take arguments. Even if a pragma is supported by an MPLAB XC compiler, this support cannot apply to all of the pragma's arguments. This is indicated in the table.

**TABLE B-7: SUPPORT FOR NON-STANDARD PRAGMAS**

IAR Compatibility Mode			
Pragma	MPLAB XC8	MPLAB XC16	MPLAB XC32
bitfields	ignore	ignore	ignore
data_alignment	ignore	support	support
diag_default	ignore	ignore	ignore
diag_error	ignore	ignore	ignore
diag_remark	ignore	ignore	ignore
diag_suppress	ignore	ignore	ignore
diag_warning	ignore	ignore	ignore
include_alias	ignore	ignore	ignore
inline	support (no args)	support (no args)	support (no args)
language	ignore	ignore	ignore
location	ignore	support	support
message	support	native support	native support
object_attribute	ignore	ignore	ignore
optimize	ignore	native support	native support
pack	ignore	native support	native support
__printf_args	support	support	support
required	ignore	support	support
rtmodel	ignore	ignore	ignore
__scanf_args	ignore	support	support
section	ignore	support	support
segment	ignore	support	support
swi_number	ignore	ignore	ignore
type_attribute	ignore	ignore	ignore
weak	ignore	native support	native support

---

---

## Appendix C. Error and Warning Messages

---

---

### C.1 INTRODUCTION

This chapter lists the MPLAB XC8 C Compiler error, warning, and advisory messages with an explanation of each message. This is the complete and historical message set covering all former HI-TECH C compilers and all compiler versions. Not all messages shown here will be relevant for the compiler version you are using.

Most messages have been assigned a unique number that appears in brackets before each message description. It is also printed by the compiler when the message is issued. The messages shown here are sorted by their number. Unnumbered messages appear toward the end and are sorted alphabetically.

The name of the application(s) that could have produced the messages are listed in brackets opposite the error message. In some cases examples of code or options that could trigger the error are given. The use of \* in the error message is used to represent a string that the compiler will substitute that is specific to that particular error.

Note that one problem in your C or assembler source code can trigger more than one error message. You should attempt to resolve errors or warnings in the order in which they are produced.

#### MESSAGES 1-249

##### **(1) too many errors (\*)**

**(all applications)**

The executing compiler application has encountered too many errors and will exit immediately. Other uncompiled source files will be processed, but the compiler applications that would normally be executed in due course will not be run. The number of errors that can be accepted is controlled using the `--ERRORS` option, See [Section 4.8.29 "--ERRORS: Maximum Number of Errors"](#).

##### **(2) error/warning (\*) generated but no description available**

**(all applications)**

The executing compiler application has emitted a message (advisory/warning/error), but there is no description available in the message description file (MDF) to print. This could be because the MDF is out-of-date, or the message issue has not been translated into the selected language.

##### **(3) malformed error information on line \* in file \***

**(all applications)**

The compiler has attempted to load the messages for the selected language, but the message description file (MDF) was corrupted and could not be read correctly.

##### **(100) unterminated #if[n][def] block from line \***

**(Preprocessor)**

A `#if` or similar block was not terminated with a matching `#endif`, for example:

```
#if INPUT          /* error flagged here */
void main(void)
{
    run();
}                  /* no #endif was found in this module */
```

## (101) **#\* cannot follow #else**

*(Preprocessor)*

A `#else` or `#elif` has been used in the same conditional block as a `#else`. These can only follow a `#if`, for example:

```
#ifdef FOO
    result = foo;
#else
    result = bar;
#elif defined(NEXT)    /* the #else above terminated the #if */
    result = next(0);
#endif
```

## (102) **#\* must be in an #if**

*(Preprocessor)*

The `#elif`, `#else` or `#endif` directive must be preceded by a matching `#if` line. If there is an apparently corresponding `#if` line, check for things like extra `#endifs`, or improperly terminated comments, for example:

```
#ifdef FOO
    result = foo;
#endif
    result = bar;
#elif defined(NEXT)    /* the #endif above terminated the #if */
    result = next(0);
#endif
```

## (103) **#error: \***

*(Preprocessor)*

This is a programmer generated error; there is a directive causing a deliberate error. This is normally used to check compile time defines, etc. Remove the directive to remove the error, but first determine why the directive is there.

## (104) **preprocessor #assert failure**

*(Preprocessor)*

The argument to a preprocessor `#assert` directive has evaluated to zero. This is a programmer induced error.

```
#assert SIZE == 4    /* size should never be 4 */
```

## (105) **no #asm before #endasm**

*(Preprocessor)*

A `#endasm` operator has been encountered, but there was no previous matching `#asm`, for example:

```
void cleardog(void)
{
    clrwdt
#endasm    /* in-line assembler ends here,
           only where did it begin? */
}
```

## (106) **nested #asm directives**

*(Preprocessor)*

It is not legal to nest `#asm` directives. Check for a missing or misspelled `#endasm` directive, for example:

```
#asm
    MOVE    r0, #0aah
#asm      ; previous #asm must be closed before opening another
    SLEEP
#endasm
```

# Error and Warning Messages

---

## (107) illegal # directive ""

(Preprocessor, Parser)

The compiler does not understand the # directive. It is probably a misspelling of a directive token, for example:

```
#indef DEBUG /* oops -- that should be #undef DEBUG */
```

## (108) #if[n][def] without an argument

(Preprocessor)

The preprocessor directives #if, #ifdef, and #ifndef must have an argument. The argument to #if should be an expression, while the argument to #ifdef or #ifndef should be a single name, for example:

```
#if /* oops -- no argument to check */
    output = 10;
#else
    output = 20;
#endif
```

## (109) #include syntax error

(Preprocessor)

The syntax of the filename argument to #include is invalid. The argument to #include must be a valid file name, either enclosed in double quotes "" or angle brackets < >. Spaces should not be included, and the closing quote or bracket must be present. There should be nothing else on the line other than comments, for example:

```
#include stdio.h /* oops -- should be: #include <stdio.h> */
```

## (110) too many file arguments; usage: cpp [input [output]]

(Preprocessor)

CPP should be invoked with at most two file arguments. Contact Microchip Technical Support if the preprocessor is being executed by a compiler driver.

## (111) redefining preprocessor macro ""

(Preprocessor)

The macro specified is being redefined to something different than the original definition. If you want to deliberately redefine a macro, use #undef first to remove the original definition, for example:

```
#define ONE 1
/* elsewhere: */
/* Is this correct? It will overwrite the first definition. */
#define ONE one
```

## (112) #define syntax error

(Preprocessor)

A macro definition has a syntax error. This could be due to a macro or formal parameter name that does not start with a letter or a missing closing parenthesis, ), for example:

```
#define FOO(a, 2b) bar(a, 2b) /* 2b is not to be! */
```

## (113) unterminated string in preprocessor macro body

(Preprocessor, Assembler)

A macro definition contains a string that lacks a closing quote.

## (114) illegal #undef argument

(Preprocessor)

The argument to #undef must be a valid name. It must start with a letter, for example:

```
#undef 6YY /* this isn't a valid symbol name */
```

## (115) recursive preprocessor macro definition of "" defined by "" (Preprocessor)

The named macro has been defined in such a manner that expanding it causes a recursive expansion of itself.

## (116) end of file within preprocessor macro argument from line \* (Preprocessor)

A macro argument has not been terminated. This probably means the closing parenthesis has been omitted from a macro invocation. The line number given is the line where the macro argument started, for example:

```
#define FUNC(a, b) func(a+b)
FUNC(5, 6; /* oops -- where is the closing bracket? */
```

## (117) misplaced constant in #if (Preprocessor)

A constant in a #if expression should only occur in syntactically correct places. This error is probably caused by omission of an operator, for example:

```
#if FOO BAR /* oops -- did you mean: #if FOO == BAR ? */
```

## (118) stack overflow processing #if expression (Preprocessor)

The preprocessor filled up its expression evaluation stack in a #if expression. Simplify the expression – it probably contains too many parenthesized subexpressions.

## (119) invalid expression in #if line (Preprocessor)

This is an internal compiler error. Contact Microchip Technical Support with details.

## (120) operator "" in incorrect context (Preprocessor)

An operator has been encountered in a #if expression that is incorrectly placed (two binary operators are not separated by a value), for example:

```
#if FOO * % BAR == 4 /* what is "*" %" ? */
#define BIG
#endif
```

## (121) expression stack overflow at operator "" (Preprocessor)

Expressions in #if lines are evaluated using a stack with a size of 128. It is possible for very complex expressions to overflow this. Simplify the expression.

## (122) unbalanced parenthesis at operator "" (Preprocessor)

The evaluation of a #if expression found mismatched parentheses. Check the expression for correct parenthesizing, for example:

```
#if ((A) + (B) /* oops -- a missing ), I think */
#define ADDED
#endif
```

## (123) misplaced "?" or ":"; previous operator is "" (Preprocessor)

A colon operator has been encountered in a #if expression that does not match up with a corresponding ? operator, for example:

```
#if XXX : YYY /* did you mean: #if COND ? XXX : YYY */
```



# Error and Warning Messages

---

## (124) illegal character "\*" in #if (Preprocessor)

There is a character in a #if expression that should not be there. Valid characters are the letters, digits, and those comprising the acceptable operators, for example:

```
#if YYZ /* what are these characters doing here? */
    int m;
#endif
```

## (125) illegal character (\* decimal) in #if (Preprocessor)

There is a non-printable character in a #if expression that should not be there. Valid characters are the letters, digits, and those comprising the acceptable operators, for example:

```
#if ^S YYZ /* what is this control characters doing here? */
    int m;
#endif
```

## (126) strings can't be used in #if (Preprocessor)

The preprocessor does not allow the use of strings in #if expressions, for example:

```
/* no string operations allowed by the preprocessor */
#if MESSAGE > "hello"
#define DEBUG
#endif
```

## (127) bad syntax for defined() in #[el]if (Preprocessor)

The defined() pseudo-function in a preprocessor expression requires its argument to be a single name. The name must start with a letter and should be enclosed in parentheses, for example:

```
/* oops -- defined expects a name, not an expression */
#if defined(a&b)
    input = read();
#endif
```

## (128) illegal operator in #if (Preprocessor)

A #if expression has an illegal operator. Check for correct syntax, for example:

```
#if FOO = 6 /* oops -- should that be: #if FOO == 5 ? */
```

## (129) unexpected "\" in #if (Preprocessor)

The *backslash* is incorrect in the #if statement, for example:

```
#if FOO == \34
    #define BIG
#endif
```

## (130) unknown type "\*" in #[el]if sizeof() (Preprocessor)

An unknown type was used in a preprocessor sizeof(). The preprocessor can only evaluate sizeof() with basic types, or pointers to basic types, for example:

```
#if sizeof(unt) == 2 /* should be: #if sizeof(int) == 2 */
    i = 0xFFFF;
#endif
```

## (131) illegal type combination in #[el]if sizeof() (Preprocessor)

The preprocessor found an illegal type combination in the argument to `sizeof()` in a `#if` expression, for example:

```
/* To sign, or not to sign, that is the error. */
#if sizeof(signed unsigned int) == 2
    i = 0xFFFF;
#endif
```

## (132) no type specified in #[el]if sizeof() (Preprocessor)

`sizeof()` was used in a preprocessor `#if` expression, but no type was specified. The argument to `sizeof()` in a preprocessor expression must be a valid simple type, or pointer to a simple type, for example:

```
#if sizeof() /* oops -- size of what? */
    i = 0;
#endif
```

## (133) unknown type code (0x\*) in #[el]if sizeof() (Preprocessor)

The preprocessor has made an internal error in evaluating a `sizeof()` expression. Check for a malformed type specifier. This is an internal error. Contact Microchip Technical Support with details.

## (134) syntax error in #[el]if sizeof() (Preprocessor)

The preprocessor found a syntax error in the argument to `sizeof` in a `#if` expression. Probable causes are mismatched parentheses and similar things, for example:

```
#if sizeof(int == 2) // oops - should be: #if sizeof(int) == 2
    i = 0xFFFF;
#endif
```

## (135) unknown operator (\*) in #if (Preprocessor)

The preprocessor has tried to evaluate an expression with an operator it does not understand. This is an internal error. Contact Microchip Technical Support with details.

## (137) strange character "\*" after ## (Preprocessor)

A character has been seen after the token catenation operator `##` that is neither a letter nor a digit. Because the result of this operator must be a legal token, the operands must be tokens containing only letters and digits, for example:

```
/* the ' character will not lead to a valid token */
#define cc(a, b) a ## 'b
```

## (138) strange character (\*) after ## (Preprocessor)

An unprintable character has been seen after the token catenation operator `##` that is neither a letter nor a digit. Because the result of this operator must be a legal token, the operands must be tokens containing only letters and digits, for example:

```
/* the ' character will not lead to a valid token */
#define cc(a, b) a ## 'b
```

# Error and Warning Messages

---

**(139) end of file in comment** *(Preprocessor)*

End of file was encountered inside a comment. Check for a missing closing comment flag, for example:

```
/* Here the comment begins. I'm not sure where I end, though
}
```

**(140) can't open \* file "": \*** *(Driver, Preprocessor, Code Generator, Assembler)*

The command file specified could not be opened for reading. Confirm the spelling and path of the file specified on the command line, for example:

```
xc8 @communds
```

should that be:

```
xc8 @commands
```

**(141) can't open \* file "": \*** *(Any)*

An output file could not be created. Confirm the spelling and path of the file specified on the command line.

**(144) too many nested #if blocks** *(Preprocessor)*

#if, #ifdef, etc., blocks can only be nested to a maximum of 32.

**(146) #include filename too long** *(Preprocessor)*

A filename constructed while looking for an include file has exceeded the length of an internal buffer. Because this buffer is 4096 bytes long, this is unlikely to happen.

**(147) too many #include directories specified** *(Preprocessor)*

A maximum of 7 directories can be specified for the preprocessor to search for include files. The number of directories specified with the driver is too many.

**(148) too many arguments for preprocessor macro** *(Preprocessor)*

A macro can only have up to 31 parameters, per the C Standard.

**(149) preprocessor macro work area overflow** *(Preprocessor)*

The total length of a macro expansion has exceeded the size of an internal table. This table is normally 32768 bytes long. Thus any macro expansion must not expand to a total of more than 32K bytes.

**(150) illegal "\_\_\_" preprocessor macro ""** *(Preprocessor)*

This is an internal compiler error. Contact Microchip Technical Support with details.

**(151) too many arguments in preprocessor macro expansion** *(Preprocessor)*

There were too many arguments supplied in a macro invocation. The maximum number allowed is 31.

**(152) bad dp/nargs in openpar(): c = \*** *(Preprocessor)*

This is an internal compiler error. Contact Microchip Technical Support with details.

# MPLAB® XC8 C Compiler User's Guide

---

- (153) out of space in preprocessor macro \* argument expansion** *(Preprocessor)*  
A macro argument has exceeded the length of an internal buffer. This buffer is normally 4096 bytes long.
- (155) work buffer overflow concatenating ""** *(Preprocessor)*  
This is an internal compiler error. Contact Microchip Technical Support with details.
- (156) work buffer "" overflow** *(Preprocessor)*  
This is an internal compiler error. Contact Microchip Technical Support with details.
- (157) can't allocate \* bytes of memory** *(Code Generator, Assembler)*  
This is an internal compiler error. Contact Microchip Technical Support with details.
- (158) invalid disable in preprocessor macro ""** *(Preprocessor)*  
This is an internal compiler error. Contact Microchip Technical Support with details.
- (159) too many calls to unget()** *(Preprocessor)*  
This is an internal compiler error. Contact Microchip Technical Support with details.
- (161) control line "" within preprocessor macro expansion** *(Preprocessor)*  
A preprocessor control line (one starting with a #) has been encountered while expanding a macro. This should not happen.
- (162) #warning: \*** *(Preprocessor, Driver)*  
This warning is either the result of user-defined #warning preprocessor directive, or the driver encountered a problem reading the map file. If the latter, contact Microchip Technical Support with details
- (163) unexpected text in control line ignored** *(Preprocessor)*  
This warning occurs when extra characters appear on the end of a control line. The extra text will be ignored, but a warning is issued. It is preferable (and in accordance with Standard C) to enclose the text as a comment, for example:  

```
#if defined(END)
#define NEXT
#endif END /* END would be better in a comment here */
```
- (164) #include filename "" was converted to lower case** *(Preprocessor)*  
The #include file name had to be converted to lowercase before it could be opened, for example:  

```
#include <STDIO.H> /* oops -- should be: #include <stdio.h> */
```
- (165) #include filename "" does not match actual name (check upper/lower case)** *(Preprocessor)*  
In Windows versions this means the file to be included actually exists and is spelled the same way as the #include filename; however, the case of each does not exactly match. For example, specifying #include "code.c" will include Code.c, if it is found. In Linux versions this warning could occur if the file wasn't found.

# Error and Warning Messages

---

## **(166) too few values specified with option ""** *(Preprocessor)*

The list of values to the preprocessor (CPP) `-s` option is incomplete. This should not happen if the preprocessor is being invoked by the compiler driver. The values passed to this option represent the sizes of `char`, `short`, `int`, `long`, `float` and `double` types.

## **(167) too many values specified with `-S` option; "" unused** *(Preprocessor)*

There were too many values supplied to the `-S` preprocessor option. See message 166.

## **(168) unknown option ""** *(Any)*

The option given to the component which caused the error is not recognized.

## **(169) strange character (\*) after ##** *(Preprocessor)*

There is an unexpected character after `#`.

## **(170) symbol "" in undef was never defined** *(Preprocessor)*

The symbol supplied as argument to `#undef` was not already defined. This warning can be disabled with some compilers. This warning can be avoided with code like:

```
#ifdef SYM
  #undef SYM /* only undefine if defined */
#endif
```

## **(171) wrong number of preprocessor macro arguments for "" (\* instead of \*)** *(Preprocessor)*

A macro has been invoked with the wrong number of arguments, for example:

```
#define ADD(a, b) (a+b)
ADD(1, 2, 3) /* oops -- only two arguments required */
```

## **(172) formal parameter expected after #** *(Preprocessor)*

The stringization operator `#` (not to be confused with the leading `#` used for preprocessor control lines) must be followed by a formal macro parameter, for example:

```
#define str(x) #y /* oops -- did you mean x instead of y? */
```

If you need to stringize a token, you will need to define a special macro to do it, for example:

```
#define __mkstr__(x) #x
```

then use `__mkstr__(token)` wherever you need to convert a token into a string.

## **(173) undefined symbol "" in #if; 0 used** *(Preprocessor)*

A symbol on a `#if` expression was not a defined preprocessor macro. For the purposes of this expression, its value has been taken as zero. This warning can be disabled with some compilers. Example:

```
#if FOO+BAR /* e.g. FOO was never #defined */
  #define GOOD
#endif
```

## (174) multi-byte constant "" isn't portable (Preprocessor)

Multi-byte constants are not portable; and, in fact, will be rejected by later passes of the compiler, for example:

```
#if CHAR == 'ab'
    #define MULTI
#endif
```

## (175) division by zero in #if; zero result assumed (Preprocessor)

Inside a #if expression, there is a division by zero which has been treated as yielding zero, for example:

```
#if foo/0 /* divide by 0: was this what you were intending? */
    int a;
#endif
```

## (176) missing newline (Preprocessor)

A new line is missing at the end of the line. Each line, including the last line, must have a new line at the end. This problem is normally introduced by editors.

## (177) symbol "" in -U option was never defined (Preprocessor)

A macro name specified in a -U option to the preprocessor was not initially defined, and thus cannot be undefined.

## (179) nested comments (Preprocessor)

This warning is issued when nested comments are found. A nested comment can indicate that a previous closing comment marker is missing or malformed, for example:

```
output = 0; /* a comment that was left unterminated
flag = TRUE; /* next comment:
                hey, where did this line go? */
```

## (180) unterminated comment in included file (Preprocessor)

Comments begun inside an included file must end inside the included file.

## (181) non-scalar types can't be converted to other types (Parser)

You cannot convert a structure, union, or array to another type, for example:

```
struct TEST test;
struct TEST * sp;
sp = test; /* oops -- did you mean: sp = &test; ? */
```

## (182) illegal conversion between types (Parser)

This expression implies a conversion between incompatible types, i.e., a conversion of a structure type into an integer, for example:

```
struct LAYOUT layout;
int i;
layout = i; /* int cannot be converted to struct */
```

Note that even if a structure only contains an int, for example, it cannot be assigned to an int variable, and vice versa.

# Error and Warning Messages

---

## (183) function or function pointer required (Parser)

Only a function or function pointer can be the subject of a function call, for example:

```
int a, b, c, d;
a = b(c+d);    /* b is not a function --
                did you mean a = b*(c+d) ? */
```

## (184) calling an interrupt function is illegal (Parser)

A function-qualified `interrupt` cannot be called from other functions. It can only be called by a hardware (or software) interrupt. This is because an `interrupt` function has special function entry and exit code that is appropriate only for calling from an interrupt. An `interrupt` function can call other non-`interrupt` functions.

## (185) function does not take arguments (Parser, Code Generator)

This function has no parameters, but it is called here with one or more arguments, for example:

```
int get_value(void);
void main(void)
{
    int input;
    input = get_value(6); /* oops --
                           parameter should not be here */
}
```

## (186) too many function arguments (Parser)

This function does not accept as many arguments as there are here.

```
void add(int a, int b);
add(5, 7, input); /* call has too many arguments */
```

## (187) too few function arguments (Parser)

This function requires more arguments than are provided in this call, for example:

```
void add(int a, int b);
add(5); /* this call needs more arguments */
```

## (188) constant expression required (Parser)

In this context an expression is required that can be evaluated to a constant at compile time, for example:

```
int a;
switch(input) {
    case a: /* oops!
            cannot use variable as part of a case label */
        input++;
}
```

## (189) illegal type for array dimension (Parser)

An array dimension must be either an integral type or an enumerated value.

```
int array[12.5]; /* oops -- twelve and a half elements, eh? */
```

## (190) illegal type for index expression (Parser)

An index expression must be either integral or an enumerated value, for example:

```
int i, array[10];
i = array[3.5]; /* oops --
                exactly which element do you mean? */
```

## (191) cast type must be scalar or void (Parser)

A typecast (an abstract type declarator enclosed in parentheses) must denote a type which is either scalar (i.e., not an array or a structure) or the type `void`, for example:

```
lip = (long [])input; /* oops -- possibly: lip = (long *)input */
```

## (192) undefined identifier "\*" (Parser)

This symbol has been used in the program, but has not been defined or declared. Check for spelling errors if you think it has been defined.

## (193) not a variable identifier "\*" (Parser)

This identifier is not a variable; it can be some other kind of object, i.e., a label.

## (194) ")" expected (Parser)

A *closing parenthesis*, `)`, was expected here. This can indicate you have left out this character in an expression, or you have some other syntax error. The error is flagged on the line at which the code first starts to make no sense. This can be a statement following the incomplete expression, for example:

```
if(a == b /* the closing parenthesis is missing here */
    b = 0; /* the error is flagged here */
```

## (195) expression syntax (Parser)

This expression is badly formed and cannot be parsed by the compiler, for example:

```
a /=% b; /* oops -- possibly that should be: a /= b; */
```

## (196) struct/union required (Parser)

A structure or union identifier is required before a *dot* `."`, for example:

```
int a;
a.b = 9; /* oops -- a is not a structure */
```

## (197) struct/union member expected (Parser)

A structure or union member name must follow a *dot* `."` or an arrow (`"->"`).

## (198) undefined struct/union "\*" (Parser)

The specified structure or union tag is undefined, for example:

```
struct WHAT what; /* a definition for WHAT was never seen */
```

## (199) logical type required (Parser)

The expression used as an operand to `if`, `while` statements or to boolean operators like `!` and `&&` must be a scalar integral type, for example:

```
struct FORMAT format;
if(format) /* this operand must be a scalar type */
    format.a = 0;
```



# Error and Warning Messages

---

## (200) taking the address of a register variable is illegal (Parser)

A variable declared register cannot have storage allocated for it in memory, and thus it is illegal to attempt to take the address of it by applying the & operator, for example:

```
int * proc(register int in)
{
    int * ip = &in;
    /* oops -- in cannot have an address to take */
    return ip;
}
```

## (201) taking the address of this object is illegal (Parser)

The expression which was the operand of the & operator is not one that denotes memory storage (“an lvalue”) and therefore its address cannot be defined, for example:

```
ip = &8; /* oops -- you cannot take the address of a literal */
```

## (202) only lvalues can be assigned to or modified (Parser)

Only an lvalue (i.e., an identifier or expression directly denoting addressable storage) can be assigned to or otherwise modified, for example:

```
int array[10];
int * ip;
char c;
array = ip; /* array is not a variable,
            it cannot be written to */
```

A typecast does not yield an lvalue, for example:

```
/* the contents of c cast to int
   is only a intermediate value */
(int)c = 1;
```

However, you can write this using pointers:

```
*(int *)&c = 1
```

## (203) illegal operation on bit variable (Parser)

Not all operations on bit variables are supported. This operation is one of those, for example:

```
bit b;
int * ip;
ip = &b; /* oops --
        cannot take the address of a bit object */
```

## (204) void function can't return a value (Parser)

A void function cannot return a value. Any return statement should not be followed by an expression, for example:

```
void run(void)
{
    step();
    return 1;
    /* either run should not be void, or remove the 1 */
}
```

## (205) integral type required (Parser)

This operator requires operands that are of integral type only.

**(206) illegal use of void expression** **(Parser)**

A `void` expression has no value and therefore you cannot use it anywhere an expression with a value is required, i.e., as an operand to an arithmetic operator.

**(207) simple type required for ""** **(Parser)**

A simple type (i.e., not an array or structure) is required as an operand to this operator.

**(208) operands of "" not same type** **(Parser)**

The operands of this operator are of different pointers, for example:

```
int * ip;
char * cp, * cp2;
cp = flag ? ip : cp2;
/* result of ? : will be int * or char * */
```

Possibly, you meant something like:

```
cp = flag ? (char *)ip : cp2;
```

**(209) type conflict** **(Parser)**

The operands of this operator are of incompatible types.

**(210) bad size list** **(Parser)**

This is an internal compiler error. Contact Microchip Technical Support with details.

**(211) taking sizeof bit is illegal** **(Parser)**

It is illegal to use the `sizeof` operator with the `C bit` type. When used against a type, the `sizeof` operator gives the number of bytes required to store an object that type. Therefore its usage with the `bit` type make no sense and it is an illegal operation.

**(212) missing number after pragma "pack"** **(Parser)**

The `pragma pack` requires a decimal number as argument. This specifies the alignment of each member within the structure. Use this with caution as some processors enforce alignment and will not operate correctly if word fetches are made on odd boundaries, for example:

```
#pragma pack /* what is the alignment value */
```

Possibly, you meant something like:

```
#pragma pack 2
```

**(214) missing number after pragma "interrupt\_level"** **(Parser)**

The `pragma interrupt_level` requires an argument to indicate the interrupt level. It will be the value 1 for mid-range devices, or 1 or 2 or PIC18 devices.

**(215) missing argument to pragma "switch"** **(Parser)**

The `pragma switch` requires an argument of `auto`, `direct` or `simple`, for example:

```
#pragma switch /* oops -- this requires a switch mode */
```

Possibly, you meant something like:

```
#pragma switch simple
```

# Error and Warning Messages

---

## (216) missing argument to pragma "psect" (Parser)

The `pragma psect` requires an argument of the form `oldname = newname` where `oldname` is an existing psect name known to the compiler, and `newname` is the desired new name, for example:

```
#pragma psect /* oops -- this requires an psect to redirect */
```

Possibly, you meant something like:

```
#pragma psect text=specialtext
```

## (218) missing name after pragma "inline" (Parser)

The `inline` pragma expects the name of a function to follow. The function name must be recognized by the code generator for it to be expanded; other functions are not altered, for example:

```
#pragma inline /* what is the function name? */
```

Possibly, you meant something like:

```
#pragma inline memcpy
```

## (219) missing name after pragma "printf\_check" (Parser)

The `printf_check` pragma expects the name of a function to follow. This specifies printf-style format string checking for the function, for example:

```
#pragma printf_check /* what function is to be checked? */
```

Possibly, you meant something like:

```
#pragma printf_check sprintf
```

Pragmas for all the standard printf-like function are already contained in `<stdio.h>`.

## (220) exponent expected (Parser)

A floating-point constant must have at least one digit after the `e` or `E`, for example:

```
float f;  
f = 1.234e; /* oops -- what is the exponent? */
```

## (221) hexadecimal digit expected (Parser)

After `0x` should follow at least one of the HEX digits 0-9 and A-F or a-f, for example:

```
a = 0xg6; /* oops -- was that meant to be a = 0xf6 ? */
```

## (222) binary digit expected (Parser)

A binary digit was expected following the `0b` format specifier, for example:

```
i = 0bf000; /* oops -- f000 is not a base two value */
```

## (223) digit out of range (Parser, Assembler)

A digit in this number is out of range of the radix for the number, i.e., using the digit 8 in an octal number, or HEX digits A-F in a decimal number. An octal number is denoted by the digit string commencing with a zero, while a HEX number starts with "0X" or "0x". For example:

```
int a = 058;  
/* leading 0 implies octal which has digits 0 - 7 */
```

**(224) illegal "#" directive** **(Parser)**

An illegal # preprocessor has been detected. Likely, a directive has been misspelled in your code somewhere.

**(225) missing character in character constant** **(Parser)**

The character inside the single quotes is missing, for example:

```
char c = "; /* the character value of what? */
```

**(226) char const too long** **(Parser)**

A character constant enclosed in single quotes cannot contain more than one character, for example:

```
c = '12'; /* oops -- only one character can be specified */
```

**(227) "." expected after ".."** **(Parser)**

The only context in which two successive dots can appear is as part of the *ellipsis* symbol, which must have 3 dots. (An *ellipsis* is used in function prototypes to indicate a variable number of parameters.)

Either . . was meant to be an *ellipsis* symbol which would require you to add an extra *dot*, or it was meant to be a *structure member operator* which would require you to remove one *dot*.

**(228) illegal character (\*)** **(Parser)**

This character is illegal in the C code. Valid characters are the letters, digits and those comprising the acceptable operators, for example:

```
c = a; /* oops -- did you mean c = 'a'; ? */
```

**(229) unknown qualifier "" given to -A** **(Parser)**

This is an internal compiler error. Contact Microchip Technical Support with details.

**(230) missing argument to -A** **(Parser)**

This is an internal compiler error. Contact Microchip Technical Support with details.

**(231) unknown qualifier "" given to -l** **(Parser)**

This is an internal compiler error. Contact Microchip Technical Support with details.

**(232) missing argument to -l** **(Parser)**

This is an internal compiler error. Contact Microchip Technical Support with details.

**(233) bad -Q option ""** **(Parser)**

This is an internal compiler error. Contact Microchip Technical Support with details.

**(234) close error** **(Parser)**

This is an internal compiler error. Contact Microchip Technical Support with details.

## (236) simple integer expression required

(Parser)

A simple integral expression is required after the operator @, used to associate an absolute address with a variable, for example:

```
int address;
char LOCK @ address;
```

## (237) function "" redefined

(Parser)

More than one definition for a function has been encountered in this module. Function overloading is illegal, for example:

```
int twice(int a)
{
    return a*2;
}
/* only one prototype & definition of rv can exist */
long twice(long a)
{
    return a*2;
}
```

## (238) illegal initialization

(Parser)

You cannot initialize a typedef declaration, because it does not reserve any storage that can be initialized, for example:

```
/* oops -- uint is a type, not a variable */
typedef unsigned int uint = 99;
```

## (239) identifier "" redefined (from line \*)

(Parser)

This identifier has already been defined in the same scope. It cannot be defined again, for example:

```
int a; /* a filescope variable called "a" */
int a; /* attempting to define another of the same name */
```

Note that variables with the same name, but defined with different scopes, are legal; but, not recommended.

## (240) too many initializers

(Parser)

There are too many initializers for this object. Check the number of initializers against the object definition (array or structure), for example:

```
/* three elements, but four initializers */
int ival[3] = { 2, 4, 6, 8};
```

## (241) initialization syntax

(Parser)

The initialization of this object is syntactically incorrect. Check for the correct placement and number of braces and commas, for example:

```
int iarray[10] = {'a', 'b', 'c'};
/* oops -- one two many {s */
```

## (242) illegal type for switch expression

(Parser)

A `switch` operation must have an expression that is either an integral type or an enumerated value, e.g:

```
double d;
switch(d) { /* oops -- this must be integral */
    case '1.0':
        d = 0;
}
```

## (243) inappropriate break/continue

(Parser)

A `break` or `continue` statement has been found that is not enclosed in an appropriate control structure. A `continue` can only be used inside a `while`, `for`, or `do while` loop, while `break` can only be used inside those loops or a `switch` statement, for example:

```
switch(input) {
    case 0:
        if(output == 0)
            input = 0xff;
        } /* oops! this should not be here; it closed the switch */
        break; /* this should be inside the switch */
```

## (244) "default" case redefined

(Parser)

Only one `default` label is allowed to be in a `switch` statement. You have more than one, for example:

```
switch(a) {
default: /* if this is the default case... */
    b = 9;
    break;
default: /* then what is this? */
    b = 10;
    break;
```

## (245) "default" case not in switch

(Parser)

A label has been encountered called `default`, but it is not enclosed by a `switch` statement. A `default` label is only legal inside the body of a `switch` statement.

If there is a `switch` statement before this `default` label, there could be one too many closing braces in the `switch` code. That would prematurely terminate the `switch` statement. See message 246.

## (246) case label not in switch

(Parser)

A case label has been encountered, but there is no enclosing switch statement. A case label can only appear inside the body of a switch statement.

If there is a switch statement before this case label, there might be one too many closing braces in the switch code. That would prematurely terminate the switch statement, for example:

```
switch(input) {
  case '0':
    count++;
    break;
  case '1':
    if(count>MAX)
      count= 0;
  }          /* oops -- this shouldn't be here */
  break;
  case '2':  /* error flagged here */
```

## (247) duplicate label ""

(Parser)

The same name is used for a label more than once in this function. Note that the scope of labels is the entire function, not just the block that encloses a label, for example:

```
start:
  if(a > 256)
    goto end;
start:          /* error flagged here */
  if(a == 0)
    goto start; /* which start label do I jump to? */
```

## (248) inappropriate "else"

(Parser)

An else keyword has been encountered that cannot be associated with an if statement. This can mean there is a missing brace or other syntactic error, for example:

```
/* here is a comment which I have forgotten to close...
if(a > b) {
  c = 0;
/* ... that will be closed here, thus removing the "if" */
else      /* my "if" has been lost */
  c = 0xff;
```

## (249) probable missing "}" in previous block

(Parser)

The compiler has encountered what looks like a function or other declaration, but the preceding function was ended with a closing brace. This probably means that a closing brace has been omitted from somewhere in the previous function, although it might not be the last one, for example:

```
void set(char a)
{
  PORTA = a;
/* the closing brace was left out here */
void clear(void) /* error flagged here */
{
  PORTA = 0;
}
```

## MESSAGES 250-499

### (251) array dimension redeclared (Parser)

An array dimension has been declared as a different non-zero value from its previous declaration. It is acceptable to redeclare the size of an array that was previously declared with a zero dimension; but, not otherwise, for example:

```
extern int array[5];
int array[10];          /* oops -- has it 5 or 10 elements? */
```

### (252) argument \* conflicts with prototype (Parser)

The argument specified (argument 0 is the left most argument) of this function definition does not agree with a previous prototype for this function, for example:

```
/* this is supposedly calc's prototype */
extern int calc(int, int);
int calc(int a, long int b) /* hmmm -- which is right? */
{
    return sin(b/a);
    /* error flagged here */
}
```

### (253) argument list conflicts with prototype (Parser)

The argument list in a function definition is not the same as a previous prototype for that function. Check that the number and types of the arguments are all the same.

```
extern int calc(int); /* this is supposedly calc's prototype */
int calc(int a, int b) /* hmmm -- which is right? */
{
    return a + b;
    /* error flagged here */
}
```

### (254) undefined \*: "" (Parser)

This is an internal compiler error. Contact Microchip Technical Support with details.

### (255) not a member of the struct/union "" (Parser)

This identifier is not a member of the structure or union type with which it used here, for example:

```
struct {
    int a, b, c;
} data;
if(data.d) /* oops --
           there is no member d in this structure */
    return;
```

### (256) too much indirection (Parser)

A pointer declaration can only have 16 levels of indirection.

### (257) only "register" storage class allowed (Parser)

The only storage class allowed for a function parameter is `register`, for example:

```
void process(static int input)
```



# Error and Warning Messages

---

## (258) duplicate qualifier

(Parser)

There are two occurrences of the same qualifier in this type specification. This can occur either directly or through the use of a typedef. Remove the redundant qualifier. For example:

```
typedef volatile int vint;
/* oops -- this results in two volatile qualifiers */
volatile vint very_vol;
```

## (259) object can't be qualified both far and near

(Parser)

It is illegal to qualify a type as both `far` and `near`, for example:

```
far near int spooky; /* oops -- choose far or near, not both */
```

## (260) undefined enum tag ""

(Parser)

This enum tag has not been defined, for example:

```
enum WHAT what; /* a definition for WHAT was never seen */
```

## (261) struct/union member "" redefined

(Parser)

This name of this member of the struct or union has already been used in this `struct` or `union`, for example:

```
struct {
    int a;
    int b;
    int a; /* oops -- a different name is required here */
} input;
```

## (262) struct/union "" redefined

(Parser)

A structure or union has been defined more than once, for example:

```
struct {
    int a;
} ms;
struct {
    int a;
} ms; /* was this meant to be the same name as above? */
```

## (263) members can't be functions

(Parser)

A member of a structure or a union cannot be a function. It could be a pointer to a function, for example:

```
struct {
    int a;
    int get(int); /* should be a pointer: int (*get)(int); */
} object;
```

## (264) bad bitfield type

(Parser)

A bit-field can only have a type of `int` (or `unsigned`), for example:

```
struct FREG {
    char b0:1; /* these must be part of an int, not char */
    char :6;
    char b7:1;
} freg;
```

## (265) integer constant expected

(Parser)

A *colon* appearing after a member name in a structure declaration indicates that the member is a bit-field. An integral constant must appear after the *colon* to define the number of bits in the bit-field, for example:

```
struct {
    unsigned first: /* oops -- should be: unsigned first; */
    unsigned second;
} my_struct;
```

If this was meant to be a structure with bit-fields, then the following illustrates an example:

```
struct {
    unsigned first : 4; /* 4 bits wide */
    unsigned second: 4; /* another 4 bits */
} my_struct;
```

## (266) storage class illegal

(Parser)

A structure or union member cannot be given a storage class. Its storage class is determined by the storage class of the structure, for example:

```
struct {
    /* no additional qualifiers can be present with members */
    static int first;
} ;
```

## (267) bad storage class

(Code Generator)

The code generator has encountered a variable definition whose storage class is invalid, for example:

```
auto int foo; /* auto not permitted with global variables */
int power(static int a) /* parameters cannot be static */
{
    return foo * a;
}
```

## (268) inconsistent storage class

(Parser)

A declaration has conflicting storage classes. Only one storage class should appear in a declaration, for example:

```
extern static int where; /* so is it static or extern? */
```

## (269) inconsistent type

(Parser)

Only one basic type can appear in a declaration, for example:

```
int float input; /* is it int or float? */
```

## (270) variable can't have storage class "register"

(Parser)

Only function parameters or auto variables can be declared using the `register` qualifier, for example:

```
register int gi; /* this cannot be qualified register */
int process(register int input) /* this is okay */
{
    return input + gi;
}
```

# Error and Warning Messages

---

## (271) type can't be long (Parser)

Only `int` and `float` can be qualified with `long`.  
`long char lc; /* what? */`

## (272) type can't be short (Parser)

Only `int` can be modified with `short`, for example:  
`short float sf; /* what? */`

## (273) type can't be both signed and unsigned (Parser)

The type modifiers `signed` and `unsigned` cannot be used together in the same declaration, as they have opposite meaning, for example:  
`signed unsigned int confused; /* which is it? */`

## (274) type can't be unsigned (Parser)

A floating-point type cannot be made `unsigned`, for example:  
`unsigned float uf; /* what? */`

## (275) "... " illegal in non-prototype argument list (Parser)

The *ellipsis* symbol can only appear as the last item in a prototyped argument list. It cannot appear on its own, nor can it appear after argument names that do not have types; i.e., K&R-style non-prototype function definitions. For example:

```
/* K&R-style non-prototyped function definition */
int kandr(a, b, ...)
    int a, b;
{
```

## (276) type specifier required for prototyped argument (Parser)

A type specifier is required for a prototyped argument. It is not acceptable to just have an identifier.

## (277) can't mix prototyped and non-prototyped arguments (Parser)

A function declaration can only have all prototyped arguments (i.e., with types inside the parentheses) or all K&R style arguments (i.e., only names inside the parentheses and the argument types in a declaration list before the start of the function body), for example:

```
int plus(int a, b) /* oops -- a is prototyped, b is not */
int b;
{
    return a + b;
}
```

## (278) argument "" redeclared (Parser)

The specified argument is declared more than once in the same argument list, for example:

```
/* cannot have two parameters called "a" */
int calc(int a, int a)
```

## **(279) initialization of function arguments is illegal** **(Parser)**

A function argument cannot have an initializer in a declaration. The initialization of the argument happens when the function is called and a value is provided for the argument by the calling function, for example:

```
/* oops -- a is initialized when proc is called */
extern int proc(int a = 9);
```

## **(280) arrays of functions are illegal** **(Parser)**

You cannot define an array of functions. You can, however, define an array of pointers to functions, for example:

```
int * farray[](); /* oops -- should be: int (* farray[])(); */
```

## **(281) functions can't return functions** **(Parser)**

A function cannot return a function. It can return a function pointer. A function returning a pointer to a function could be declared like this: `int (* (name()))()`. Note the many parentheses that are necessary to make the parts of the declaration bind correctly.

## **(282) functions can't return arrays** **(Parser)**

A function can return only a scalar (simple) type or a structure. It cannot return an array.

## **(283) dimension required** **(Parser)**

Only the most significant (i.e., the first) dimension in a multi-dimension array cannot be assigned a value. All succeeding dimensions must be present as a constant expression, for example:

```
/* This should be, for example: int arr[][7] */
int get_element(int arr[2][])
{
    return array[1][6];
}
```

## **(284) invalid dimension** **(Parser)**

The array dimension specified is not valid. It must be larger than 0.

```
int array[0]; // oops -- you cannot have an array of size 0
```

## **(285) no identifier in declaration** **(Parser)**

The identifier is missing in this declaration. This error can also occur when the compiler has been confused by such things as missing closing braces, for example:

```
void interrupt(void) /* what is the name of this function? */
{
}
```

## **(286) declarator too complex** **(Parser)**

This declarator is too complex for the compiler to handle. Examine the declaration and find a way to simplify it. If the compiler finds it too complex, so will anybody maintaining the code.

---

---

# Error and Warning Messages

---

---

## **(287) arrays of bits or pointers to bit are illegal** **(Parser)**

It is not legal to have an array of bits, or a pointer to bit variable, for example:

```
bit barray[10]; /* wrong -- no bit arrays */
bit * bp;      /* wrong -- no pointers to bit variables */
```

## **(288) the type 'void' is applicable only to functions** **(Parser)**

A variable cannot be `void`. Only a function can be `void`, for example:

```
int a;
void b; /* this makes no sense */
```

## **(289) the specifier 'interrupt' is applicable only to functions** **(Parser)**

The qualifier `interrupt` cannot be applied to anything except a function, for example:

```
/* variables cannot be qualified interrupt */
interrupt int input;
```

## **(290) illegal function qualifier(s)** **(Parser)**

A qualifier has been applied to a function which makes no sense in this context. Some qualifier only make sense when used with an `lvalue`, i.e., `const` or `volatile`. This can indicate that you have forgotten a star `*` that is indicating that the function should return a pointer to a qualified object, for example:

```
const char ccrv(void) /* const * char ccrv(void) perhaps? */
{
    /* error flagged here */
    return ccip;
}
```

## **(291) K&R identifier "" not an argument** **(Parser)**

This identifier, that has appeared in a K&R style argument declarator, is not listed inside the parentheses after the function name, for example:

```
int process(input)
int unput; /* oops -- that should be int input; */
{
}
```

## **(292) a function is not a valid parameter type** **(Parser)**

A function parameter cannot be a function. It can be a pointer to a function, so perhaps a `"*"` has been omitted from the declaration.

## **(293) bad size in index\_type()** **(Parser)**

This is an internal compiler error. Contact Microchip Technical Support with details.

## **(294) can't allocate \* bytes of memory** **(Code Generator, Hexmate)**

This is an internal compiler error. Contact Microchip Technical Support with details.

## **(295) expression too complex** **(Parser)**

This expression has caused overflow of the compiler's internal stack and should be rearranged or split into two expressions.

**(296) out of memory** **(Objtohex)**

This could be an internal compiler error. Contact Microchip Technical Support with details.

**(297) bad argument (\*) to tysize()** **(Parser)**

This is an internal compiler error. Contact Microchip Technical Support with details.

**(298) end of file in #asm** **(Preprocessor)**

An end of file has been encountered inside a #asm block. This probably means the #endasm is missing or misspelled, for example:

```
#asm
MOV r0, #55
MOV [r1], r0
}          /* oops -- where is the #endasm */
```

**(300) unexpected end of file** **(Parser)**

An end-of-file in a C module was encountered unexpectedly, for example:

```
void main(void)
{
    init();
    run();    /* is that it? What about the close brace */
```

**(301) end of file on string file** **(Parser)**

This is an internal compiler error. Contact Microchip Technical Support with details.

**(302) can't reopen "": \*** **(Parser)**

This is an internal compiler error. Contact Microchip Technical Support with details.

**(303) can't allocate \* bytes of memory (line \*)** **(Parser)**

The parser was unable to allocate memory for the longest string encountered, as it attempts to sort and merge strings. Try reducing the number or length of strings in this module.

**(306) can't allocate \* bytes of memory for \*** **(Code Generator)**

This is an internal compiler error. Contact Microchip Technical Support with details.

**(307) too many qualifier names** **(Parser)**

This is an internal compiler error. Contact Microchip Technical Support with details.

**(308) too many case labels in switch** **(Code Generator)**

There are too many case labels in this switch statement. The maximum allowable number of case labels in any one switch statement is 511.

**(309) too many symbols** **(Assembler, Parser)**

There are too many symbols for the assembler's symbol table. Reduce the number of symbols in your program.

# Error and Warning Messages

---

## (310) "]" expected (Parser)

A closing square bracket was expected in an array declaration or an expression using an array index, for example:

```
process(carray[idx]; /* oops --
                        should be: process(carray[idx]); */
```

## (311) closing quote expected (Parser)

A closing quote was expected for the indicated string.

## (312) "" expected (Parser)

The indicated token was expected by the parser.

## (313) function body expected (Parser)

Where a function declaration is encountered with K&R style arguments (i.e., argument names; but, no types inside the parentheses) a function body is expected to follow, for example:

```
/* the function block must follow, not a semicolon */
int get_value(a, b);
```

## (314) ";" expected (Parser)

A *semicolon* is missing from a statement. A close brace or keyword was found following a statement with no terminating *semicolon*, for example:

```
while(a) {
    b = a-- /* oops -- where is the semicolon? */
}          /* error is flagged here */
```

Note: Omitting a semicolon from statements not preceding a close brace or keyword typically results in some other error being issued for the following code which the parser assumes to be part of the original statement.

## (315) "{" expected (Parser)

An *opening brace* was expected here. This error can be the result of a function definition missing the *opening brace*, for example:

```
/* oops! no opening brace after the prototype */
void process(char c)
    return max(c, 10) * 2; /* error flagged here */
}
```

## (316) "]" expected (Parser)

A *closing brace* was expected here. This error can be the result of a initialized array missing the *closing brace*, for example:

```
char carray[4] = { 1, 2, 3, 4; /* oops -- no closing brace */
```

## (317) "(" expected (Parser)

An *opening parenthesis*, (, was expected here. This must be the first token after a *while*, *for*, *if*, *do* or *asm* keyword, for example:

```
if a == b /* should be: if(a == b) */
    b = 0;
```

## (318) string expected (Parser)

The operand to an `asm` statement must be a string enclosed in parentheses, for example:

```
asm(nop); /* that should be asm("nop");
```

## (319) while expected (Parser)

The keyword `while` is expected at the end of a `do` statement, for example:

```
do {
    func(i++);
} /* do the block while what condition is true? */
if(i > 5) /* error flagged here */
    end();
```

## (320) ":" expected (Parser)

A *colon* is missing after a `case` label, or after the keyword `default`. This often occurs when a *semicolon* is accidentally typed instead of a *colon*, for example:

```
switch(input) {
    case 0; /* oops -- that should have been: case 0: */
        state = NEW;
```

## (321) label identifier expected (Parser)

An identifier denoting a label must appear after `goto`, for example:

```
if(a)
    goto 20;
/* this is not BASIC -- a valid C label must follow a goto */
```

## (322) enum tag or "{" expected (Parser)

After the keyword `enum`, must come either an identifier that is, or will be, defined as an `enum tag`, or an opening brace, for example:

```
enum 1, 2; /* should be, for example: enum {one=1, two }; */
```

## (323) struct/union tag or "{" expected (Parser)

An identifier denoting a structure or union or an opening brace must follow a `struct` or `union` keyword, for example:

```
struct int a; /* this is not how you define a structure */
```

You might mean something like:

```
struct {
    int a;
} my_struct;
```

## (324) too many arguments for printf-style format string (Parser)

There are too many arguments for this format string. This is harmless, but can represent an incorrect format string, for example:

```
/* oops -- missed a placeholder? */
printf("%d - %d", low, high, median);
```



# Error and Warning Messages

---

## (325) error in printf-style format string (Parser)

There is an error in the format string here. The string has been interpreted as a `printf()` style format string, and it is not syntactically correct. If not corrected, this will cause unexpected behavior at runtime, for example:

```
printf("%l", 111); /* oops -- possibly: printf("%ld", 111); */
```

## (326) long int argument required in printf-style format string (Parser)

A long argument is required for this format specifier. Check the number and order of format specifiers and corresponding arguments, for example:

```
printf("%lx", 2); // possibly you meant: printf("%lx", 2L);
```

## (327) long long int argument required in printf-style format string (Parser)

A long long argument is required for this format specifier. Check the number and order of format specifiers and corresponding arguments, for example:

```
printf("%llx", 2); // possibly you meant: printf("%llx", 2LL);
```

Note that MPLAB XC8 does not provide direct support for a long long integer type.

## (328) int argument required in printf-style format string (Parser)

An integral argument is required for this printf-style format specifier. Check the number and order of format specifiers and corresponding arguments, for example:

```
printf("%d", 1.23); /* wrong number or wrong placeholder */
```

## (329) double argument required in printf-style format string (Parser)

The printf format specifier corresponding to this argument is `%f` or similar, and requires a floating-point expression. Check for missing or extra format specifiers or arguments to printf.

```
printf("%f", 44); /* should be: printf("%f", 44.0); */
```

## (330) pointer to \* argument required in printf-style format string (Parser)

A pointer argument is required for this format specifier. Check the number and order of format specifiers and corresponding arguments.

## (331) too few arguments for printf-style format string (Parser)

There are too few arguments for this format string. This would result in a garbage value being printed or converted at runtime, for example:

```
printf("%d - %d", low);  
/* oops! where is the other value to print? */
```

## (332) "interrupt\_level" should be 0 to 7 (Parser)

The pragma `interrupt_level` must have an argument from 0 to 7; however, mid-range devices only use level 1. PIC18 devices can use levels 1 or 2. For example:

```
#pragma interrupt_level 9 /* oops -- the level is too high */  
void interrupt isr(void)  
{  
    /* isr code goes here */  
}
```

## (333) unrecognized qualifier name after "strings" (Parser)

The `pragma strings` was passed a qualifier that was not identified, for example:

```
/* oops -- should that be #pragma strings const ? */
#pragma strings cinst
```

## (334) unrecognized qualifier name after "printf\_check" (Parser)

The `#pragma printf_check` was passed a qualifier that could not be identified, for example:

```
/* oops -- should that be const not cinst? */
#pragma printf_check(printf) cinst
```

## (335) unknown pragma "" (Parser)

An unknown `pragma` directive was encountered, for example:

```
#pragma rugsused myFunc w /* I think you meant regsused */
```

## (336) string concatenation across lines (Parser)

Strings on two lines will be concatenated. Check that this is the desired result, for example:

```
char * cp = "hi"
           "there"; /* this is okay,
                    but is it what you had intended? */
```

## (337) line does not have a newline on the end (Parser)

The last line in the file is missing the *newline* (operating system dependent character) from the end. Some editors will create such files, which can cause problems for include files. The ANSI C standard requires all source files to consist of complete lines only.

## (338) can't create \* file "" (Any)

The application tried to create or open the named file, but it could not be created. Check that all file path names are correct.

## (339) initializer in extern declaration (Parser)

A declaration containing the keyword `extern` has an initializer. This overrides the `extern` storage class, because to initialize an object it is necessary to define (i.e., allocate storage for) it, for example:

```
extern int other = 99; /* if it's extern and not allocated
                       storage, how can it be initialized? */
```

## (340) string not terminated by null character (Parser)

A char array is being initialized with a string literal larger than the array. Hence there is insufficient space in the array to safely append a null terminating character, for example:

```
char foo[5] = "12345"; /* the string stored in foo won't have
                        a null terminating, i.e.
                        foo = ['1', '2', '3', '4', '5'] */
```

## (343) implicit return at end of non-void function

(Parser)

A function that has been declared to return a value has an execution path that will allow it to reach the end of the function body, thus returning without a value. Either insert a `return` statement with a value, or if the function is not to return a value, declare it `void`, for example:

```
int mydiv(double a, int b)
{
    if(b != 0)
        return a/b;    /* what about when b is 0? */
}                      /* warning flagged here */
```

## (344) non-void function returns no value

(Parser)

A function that is declared as returning a value has a `return` statement that does not specify a return value, for example:

```
int get_value(void)
{
    if(flag)
        return val++;
    return;
    /* what is the return value in this instance? */
}
```

## (345) unreachable code

(Parser)

This section of code will never be executed, because there is no execution path by which it could be reached, for example:

```
while(1)                /* how does this loop finish? */
    process();
flag = FINISHED;       /* how do we get here? */
```

## (346) declaration of "" hides outer declaration

(Parser)

An object has been declared that has the same name as an outer declaration (i.e., one outside and preceding the current function or block). This is legal, but can lead to accidental use of one variable when the outer one was intended, for example:

```
int input;              /* input has filescope */
void process(int a)
{
    int input;         /* local blockscope input */
    a = input;         /* this will use the local variable.
                        Is this right? */
}
```

## (347) external declaration inside function

(Parser)

A function contains an `extern` declaration. This is legal but is invariably not desirable as it restricts the scope of the function declaration to the function body. This means that if the compiler encounters another declaration, use, or definition of the extern object later in the same file, it will no longer have the earlier declaration and thus will be unable to check that the declarations are consistent. This can lead to strange behavior of your program or signature errors at link time. It will also hide any previous declarations of the same thing, again subverting the compiler's type checking. As a general rule, always declare `extern` variables and functions outside any other functions. For example:

```
int process(int a)
{
    /* this would be better outside the function */
    extern int away;
    return away + a;
}
```

## (348) auto variable "" should not be qualified

(Parser)

An `auto` variable should not have qualifiers such as `near` or `far` associated with it. Its storage class is implicitly defined by the stack organization. An `auto` variable can be qualified with `static`, but it is then no longer `auto`.

## (349) non-prototyped function declaration for ""

(Parser)

A function has been declared using old-style (K&R) arguments. It is preferable to use prototype declarations for all functions, for example:

```
int process(input)
int input;          /* warning flagged here */
{
}
```

This would be better written:

```
int process(int input)
{
}
```

## (350) unused \* "" (from line \*)

(Parser)

The indicated object was never used in the function or module being compiled. Either this object is redundant, or the code that was meant to use it was excluded from compilation or misspelled the name of the object. Note that the symbols `rcsid` and `sccsid` are never reported as being unused.

## (352) float parameter coerced to double

(Parser)

Where a non-prototyped function has a parameter declared as `float`, the compiler converts this to a `double float`. This is because the default C type conversion conventions provide that when a floating-point number is passed to a non-prototyped function, it is converted to `double`. It is important that the function declaration be consistent with this convention, for example:

```
double inc_flt(f) /* f will be converted to double */
float f;          /* warning flagged here */
{
    return f * 2;
}
```

# Error and Warning Messages

---

## (353) sizeof external array "\*" is zero

(Parser)

The size of an external array evaluates to zero. This is probably due to the array not having an explicit dimension in the extern declaration.

## (354) possible pointer truncation

(Parser)

A pointer qualified far has been assigned to a default pointer, or a pointer qualified near, or a default pointer has been assigned to a pointer qualified near. This can result in truncation of the pointer and loss of information, depending on the memory model in use.

## (355) implicit signed to unsigned conversion

(Parser)

A signed number is being assigned or otherwise converted to a larger unsigned type. Under the ANSI C "value preserving" rules, this will result in the signed value being first sign-extended to a signed number the size of the target type, then converted to unsigned (which involves no change in bit pattern). Thus, an unexpected sign extension can occur. To ensure this does not happen, first convert the signed value to an unsigned equivalent, for example:

```
signed char sc;
unsigned int ui;
ui = sc;    /* if sc contains 0xff,
            ui will contain 0xffff for example */
```

will perform a sign extension of the char variable to the longer type. If you do not want this to take place, use a cast, for example:

```
ui = (unsigned char)sc;
```

## (356) implicit conversion of float to integer

(Parser)

A floating-point value has been assigned or otherwise converted to an integral type. This could result in truncation of the floating-point value. A typecast will make this warning go away.

```
double dd;
int i;
i = dd;    /* is this really what you meant? */
```

If you do intend to use an expression like this, then indicate that this is so by a cast:

```
i = (int)dd;
```

## (357) illegal conversion of integer to pointer

(Parser)

An integer has been assigned to, or otherwise converted to, a pointer type. This will usually mean that you have used the wrong variable. But, if this is genuinely what you want to do, use a typecast to inform the compiler that you want the conversion and the warning will be suppressed. This can also mean that you have forgotten the & address operator, for example:

```
int * ip;
int i;
ip = i;    /* oops -- did you mean ip = &i ? */
```

If you do intend to use an expression like this, then indicate that this is so by a cast:

```
ip = (int *)i;
```

## (358) illegal conversion of pointer to integer

(Parser)

A pointer has been assigned to, or otherwise converted to, an integral type. This will usually mean that you have used the wrong variable. But, if this is genuinely what you want to do, use a typecast to inform the compiler that you want the conversion and the warning will be suppressed. This can also mean that you have forgotten the \* dereference operator, for example:

```
int * ip;
int i;
i = ip;    /* oops -- did you mean i = *ip ? */
```

If you do intend to use an expression like this, indicate your intention by a cast:

```
i = (int)ip;
```

## (359) illegal conversion between pointer types

(Parser)

A pointer of one type (i.e., pointing to a particular kind of object) has been converted into a pointer of a different type. This usually means that you have used the wrong variable, but if this is genuinely what you want to do, use a typecast to inform the compiler that you want the conversion and the warning will be suppressed, for example:

```
long input;
char * cp;
cp = &input; /* is this correct? */
```

This is a common way of accessing bytes within a multi-byte variable. To indicate that this is the intended operation of the program, use a cast:

```
cp = (char *)&input; /* that's better */
```

This warning can also occur when converting between pointers to objects that have the same type, but which have different qualifiers, for example:

```
char * cp;
/* yes, but what sort of characters? */
cp = "I am a string of characters";
```

If the default type for string literals is `const char *`, then this warning is quite valid. This should be written:

```
const char * cp;
cp = "I am a string of characters"; /* that's better */
```

Omitting a qualifier from a pointer type is often disastrous, and almost certainly not what you intend.

## (360) array index out of bounds

(Parser)

An array is being indexed with a constant value that is less than zero, or greater than or equal to the number of elements in the array. This warning will not be issued when accessing an array element via a pointer variable, for example:

```
int i, * ip, input[10];
i = input[-2];          /* oops -- this element doesn't exist */
ip = &input[5];
i = ip[-2];            /* this is okay */
```

## (361) function declared implicit int

(Parser)

When the compiler encounters a function call of a function whose name is presently undefined, the compiler will automatically declare the function to be of type `int`, with unspecified (K&R style) parameters. If a definition of the function is subsequently encountered, it is possible that its type and arguments will be different from the earlier implicit declaration, causing a compiler error. The solution is to ensure that all functions are defined (or at least declared) before use, preferably with prototyped parameters. If it is necessary to make a forward declaration of a function, it should be preceded with the keywords `extern` or `static`, as appropriate. For example:

```
/* I can prevent an error arising from calls below */
extern void set(long a, int b);

void main(void)
{
    /* at this point, a prototype for set() has already been seen */
    set(10L, 6);
}
```

## (362) redundant "&" applied to array

(Parser)

The address operator `&` has been applied to an array. Because using the name of an array gives its address anyway, this is unnecessary and has been ignored, for example:

```
int array[5];
int * ip;
/* array is a constant, not a variable; the & is redundant. */
ip = &array;
```

## (363) redundant "&" or "\*" applied to function address

(Parser)

The address operator `&` has been applied to a function. Because using the name of a function gives its address anyway, this is unnecessary and has been ignored, for example:

```
extern void foo(void);
void main(void)
{
    void(*bar)(void);
    /* both assignments are equivalent */
    bar = &foo;
    bar = foo; /* the & is redundant */
}
```

## (364) attempt to modify object qualified \*

(Parser)

Objects declared `const` or `code` cannot be assigned to or modified in any other way by your program. The effect of attempting to modify such an object is compiler specific.

```
const int out = 1234; /* "out" is read only */
out = 0;              /* oops --
                       writing to a read-only object */
```

## (365) pointer to non-static object returned

(Parser)

This function returns a pointer to a non-`static` (e.g., `auto`) variable. This is likely to be an error, because the storage associated with automatic variables becomes invalid when the function returns, for example:

```
char * get_addr(void)
{
    char c;
    /* returning this is dangerous;
       the pointer could be dereferenced */
    return &c;
}
```

## (366) operands of "" not same pointer type

(Parser)

The operands of this operator are of different pointer types. This probably means you have used the wrong pointer, but if the code is actually what you intended, use a `typedef` to suppress the error message.

## (367) identifier is already extern; can't be static

(Parser)

This function was already declared `extern`, possibly through an implicit declaration. It has now been redeclared `static`, but this redeclaration is invalid.

```
void main(void)
{
    /* at this point the compiler assumes set is extern... */
    set(10L, 6);
}
/* now it finds out otherwise */
static void set(long a, int b)
{
    PORTA = a + b;
}
```

## (368) array dimension on "\*" ignored

(Preprocessor)

An array dimension on a function parameter has been ignored because the argument is actually converted to a pointer when passed. Thus arrays of any size can be passed. Either remove the dimension from the parameter, or define the parameter using pointer syntax, for example:

```
/* param should be: "int array[]" or "int *" */
int get_first(int array[10])
{
    /* warning flagged here */
    return array[0];
}
```

## (369) signed bitfields not supported

(Parser)

Only `unsigned` bit-fields are supported. If a bit-field is declared to be type `int`, the compiler still treats it as `unsigned`, for example:

```
struct {
    signed int sign: 1;    /* oops -- this must be unsigned */
    signed int value: 7;
} ;
```



# Error and Warning Messages

---

## (370) illegal basic type; int assumed (Parser)

The basic type of a cast to a qualified basic type could not be recognized and the basic type was assumed to be `int`, for example:

```
/* here ling is assumed to be int */
unsigned char bar = (unsigned ling) 'a';
```

## (371) missing basic type; int assumed (Parser)

This declaration does not include a basic type, so `int` has been assumed. This declaration is not illegal, but it is preferable to include a basic type to make it clear what is intended, for example:

```
char c;
i;      /* don't let the compiler make assumptions, use : int i */
func(); /* ditto, use: extern int func(int); */
```

## (372) ", " expected (Parser)

A *comma* was expected here. This could mean you have left out the *comma* between two identifiers in a declaration list. It can also mean that the immediately preceding type name is misspelled, and has been interpreted as an identifier, for example:

```
unsigned char a;
/* thinks: chat & b are unsigned, but where is the comma? */
unsigned chat b;
```

## (373) implicit signed to unsigned conversion (Parser)

An unsigned type was expected where a signed type was given and was implicitly cast to unsigned, for example:

```
unsigned int foo = -1;
/* the above initialization is implicitly treated as:
   unsigned int foo = (unsigned) -1; */
```

## (374) missing basic type; int assumed (Parser)

The basic type of a cast to a qualified basic type was missing and assumed to be `int`., for example:

```
int i = (signed) 2; /* (signed) assumed to be (signed int) */
```

## (375) unknown FNREC type "" (Linker)

This is an internal compiler error. Contact Microchip Technical Support with details.

## (376) bad non-zero node in call graph (Linker)

The linker has encountered a top level node in the call graph that is referenced from lower down in the call graph. This probably means the program has indirect recursion, which is not allowed when using a compiled stack.

## (378) can't create \* file "" (Hexmate)

This type of file could not be created. Is the file, or a file by this name, already in use?

## (379) bad record type "" (Linker)

This is an internal compiler error. Ensure that the object file is a valid object file. Contact Microchip Technical Support with details.

# MPLAB® XC8 C Compiler User's Guide

---

- (380) unknown record type (\*)** **(Linker)**  
This is an internal compiler error. Contact Microchip Technical Support with details.
- (381) record "" too long (\*)** **(Linker)**  
This is an internal compiler error. Contact Microchip Technical Support with details.
- (382) incomplete record: type = \*, length = \*** **(Dump, Xstrip)**  
This message is produced by the DUMP or XSTRIP utilities and indicates that the object file is not a valid object file, or that it has been truncated. Contact Microchip Technical Support with details.
- (383) text record has length (\*) too small** **(Linker)**  
This is an internal compiler error. Contact Microchip Technical Support with details.
- (384) assertion failed: file \*, line \*, expression \*** **(Linker, Parser)**  
This is an internal compiler error. Contact Microchip Technical Support with details.
- (387) illegal or too many -G options** **(Linker)**  
There has been more than one linker `-g` option, or the `-g` option did not have any arguments following. The arguments specify how the segment addresses are calculated.
- (388) duplicate -M option** **(Linker)**  
The map file name has been specified to the linker for a second time. This should not occur if you are using a compiler driver. If invoking the linker manually, ensure that only one instance of this option is present on the command line. See [Section 4.8.7 “-M: Generate Map File”](#) for information on the correct syntax for this option.
- (389) illegal or too many -O options** **(Linker)**  
This linker `-o` flag is illegal, or another `-o` option has been encountered. A `-o` option to the linker must be immediately followed by a filename with no intervening space.
- (390) missing argument to -P** **(Linker)**  
There have been too many `-p` options passed to the linker, or a `-p` option was not followed by any arguments. The arguments of separate `-p` options can be combined and separated by *commas*.
- (391) missing argument to -Q** **(Linker)**  
The `-Q` linker option requires the machine type for an argument.
- (392) missing argument to -U** **(Linker)**  
The `-U` (undefine) option needs an argument.
- (393) missing argument to -W** **(Linker)**  
The `-w` option (listing width) needs a numeric argument.

# Error and Warning Messages

---

- (394) duplicate -D or -H option** *(Linker)*
- The symbol file name has been specified to the linker for a second time. This should not occur if you are using a compiler driver. If invoking the linker manually, ensure that only one instance of either of these options is present on the command line.
- (395) missing argument to -J** *(Linker)*
- The maximum number of errors before aborting must be specified following the `-j` linker option.
- (397) usage: hlink [-options] files.obj files.lib** *(Linker)*
- Improper usage of the command-line linker. If you are invoking the linker directly, refer to Section [Section 7.2 "Operation"](#) for more details. Otherwise, this could be an internal compiler error and you should contact Microchip Technical Support with details.
- (398) output file can't be also an input file** *(Linker)*
- The linker has detected an attempt to write its output file over one of its input files. This cannot be done, because it needs to simultaneously read and write input and output files.
- (400) bad object code format** *(Linker)*
- This is an internal compiler error. The object code format of an object file is invalid. Ensure it is a valid object file. Contact Microchip Technical Support with details.
- (402) bad argument to -F** *(Objtohex)*
- The `-F` option for `objtohex` has been supplied an invalid argument. If you are not invoking this tool directly, this is an internal compiler error, and you should contact Microchip Technical Support with details.
- (403) bad -E option: ""** *(Objtohex)*
- This is an internal compiler error. Contact Microchip Technical Support with details.
- (404) bad maximum length value to -<digits>** *(Objtohex)*
- The first value to the OBJTOHEX `-n,m` HEX length/rounding option is invalid.
- (405) bad record size rounding value to -<digits>** *(Objtohex)*
- The second value to the OBJTOHEX `-n,m` HEX length/rounding option is invalid.
- (406) bad argument to -A** *(Objtohex)*
- This is an internal compiler error. Contact Microchip Technical Support with details.
- (407) bad argument to -U** *(Objtohex)*
- This is an internal compiler error. Contact Microchip Technical Support with details.
- (408) bad argument to -B** *(Objtohex)*
- This option requires an integer argument in either base 8, 10, or 16. If you are not invoking this tool directly, this is an internal compiler error, and you should contact Microchip Technical Support with details.

# MPLAB® XC8 C Compiler User's Guide

---

- (409) bad argument to -P** *(Objtohex)*  
This option requires an integer argument in either base 8, 10, or 16. If you are not invoking this tool directly, this is an internal compiler error, and you should contact Microchip Technical Support with details.
- (410) bad combination of options** *(Objtohex)*  
The combination of options supplied to OBJTOHEX is invalid.
- (412) text does not start at 0** *(Objtohex)*  
Code in some things must start at zero. Here it doesn't.
- (413) write error on ""** *(Assembler, Linker, Cromwell)*  
A write error occurred on the named file. This probably means you have run out of disk space.
- (414) read error on ""** *(Linker)*  
The linker encountered an error trying to read this file.
- (415) text offset too low in COFF file** *(Objtohex)*  
This is an internal compiler error. Contact Microchip Technical Support with details.
- (416) bad character (\*) in extended TEKHEX line** *(Objtohex)*  
This is an internal compiler error. Contact Microchip Technical Support with details.
- (417) seek error in ""** *(Linker)*  
This is an internal compiler error. Contact Microchip Technical Support with details.
- (418) image too big** *(Objtohex)*  
This is an internal compiler error. Contact Microchip Technical Support with details.
- (419) object file is not absolute** *(Objtohex)*  
The object file passed to OBJTOHEX has relocation items in it. This can indicate it is the wrong object file, or that the linker or OBJTOHEX have been given invalid options. The object output files from the assembler are relocatable, not absolute. The object file output of the linker is absolute.
- (420) too many relocation items** *(Objtohex)*  
This is an internal compiler error. Contact Microchip Technical Support with details.
- (421) too many segments** *(Objtohex)*  
This is an internal compiler error. Contact Microchip Technical Support with details.
- (422) no end record** *(Linker)*  
This object file has no end record. This probably means it is not an object file. Contact Microchip Technical Support if the object file was generated by the compiler.

# Error and Warning Messages

---

- (423) illegal record type** **(Linker)**  
There is an error in an object file. This is either an invalid object file, or an internal error in the linker. Contact Microchip Technical Support with details if the object file was created by the compiler.
- (424) record too long** **(Objtohex)**  
This is an internal compiler error. Contact Microchip Technical Support with details.
- (425) incomplete record** **(Objtohex, Libr)**  
The object file passed to OBJTOHEX or the librarian is corrupted. Contact Microchip Technical Support with details.
- (427) syntax error in list** **(Objtohex)**  
There is a syntax error in a list read by OBJTOHEX. The list is read from standard input in response to an option.
- (428) too many segment fixups** **(Objtohex)**  
This is an internal compiler error. Contact Microchip Technical Support with details.
- (429) bad segment fixups** **(Objtohex)**  
This is an internal compiler error. Contact Microchip Technical Support with details.
- (430) bad specification** **(Objtohex)**  
A list supplied to OBJTOHEX is syntactically incorrect.
- (431) bad argument to -E** **(Objtoexe)**  
This option requires an integer argument in either base 8, 10, or 16. If you are invoking `objtoexe` directly then check this argument. Otherwise, this can be an internal compiler error and you should contact Microchip Technical Support with details.
- (432) usage: objtohex [-ssymfile] [object-file [exe-file]]** **(Objtohex)**  
Improper usage of the command-line tool `objtohex`. If you are not invoking this tool directly, this is an internal compiler error, and you should contact Microchip Technical Support with details.
- (434) too many symbols (\*)** **(Linker)**  
There are too many symbols in the symbol table, which has a limit of \* symbols. Change some global symbols to local symbols to reduce the number of symbols.
- (435) bad segment selector ""** **(Linker)**  
The segment specification option (`-G`) to the linker is invalid, for example:  
`-GA/f0+10`  
Did you forget the radix?  
`-GA/f0h+10`
- (436) psect "" re-orged** **(Linker)**  
This psect has had its start address specified more than once.

## (437) missing "=" in class spec (Linker)

A class spec needs an = sign, e.g., -Ctext=ROM. See [Section 7.2.2 "-Cpsect=class"](#) for more information.

## (438) bad size in -S option (Linker)

The address given in a -S specification is invalid, it should be a valid number, in decimal, octal, or hexadecimal radix. The radix is specified by a trailing O, for octal, or H for HEX. A leading 0x can also be used for hexadecimal. Case is not important for any number or radix. Decimal is the default, for example:

```
-SCODE=f000
```

Did you forget the radix?

```
-SCODE=f000h
```

## (439) bad -D spec: "\*" (Linker)

The format of a -D specification, giving a *delta* value to a class, is invalid, for example:

```
-DCODE
```

What is the *delta* value for this class? Possibly, you meant something like:

```
-DCODE=2
```

## (440) bad delta value in -D spec (Linker)

The *delta* value supplied to a -D specification is invalid. This value should be an integer of base 8, 10, or 16.

## (441) bad -A spec: "\*" (Linker)

The format of a -A specification, giving address ranges to the linker, is invalid, for example:

```
-ACODE
```

What is the range for this class? Possibly, you meant:

```
-ACODE=0h-1ffffh
```

## (442) missing address in -A spec (Linker)

The format of a -A specification, giving address ranges to the linker, is invalid, for example:

```
-ACODE=
```

What is the range for this class? Possibly, you meant:

```
-ACODE=0h-1ffffh
```

## (443) bad low address "\*" in -A spec (Linker)

The low address given in a -A specification is invalid: it should be a valid number, in decimal, octal, or hexadecimal radix. The radix is specified by a trailing O (for octal) or H for HEX. A leading 0x can also be used for hexadecimal. Case is not important for any number or radix. Decimal is default, for example:

```
-ACODE=1fff-3ffffh
```

Did you forget the radix?

```
-ACODE=1ffffh-3ffffh
```

# Error and Warning Messages

---

## (444) expected "-" in -A spec

(Linker)

There should be a minus sign, -, between the high and low addresses in a -A linker option, for example:

```
-AROM=1000h
```

Possibly, you meant:

```
-AROM=1000h-1ffffh
```

## (445) bad high address "" in -A spec

(Linker)

The high address given in a -A specification is invalid: it should be a valid number, in decimal, octal, or hexadecimal radix. The radix is specified by a trailing O, for octal, or H for HEX. A leading 0x can also be used for hexadecimal. Case is not important for any number or radix. Decimal is the default, for example:

```
-ACODE=0h-ffff
```

Did you forget the radix?

```
-ACODE=0h-ffffh
```

See [Section 7.2.1 "-Aclass =low-high,..."](#) for more information.

## (446) bad overrun address "" in -A spec

(Linker)

The overrun address given in a -A specification is invalid: it should be a valid number, in decimal, octal, or hexadecimal radix. The radix is specified by a trailing O (for octal) or H for HEX. A leading 0x can also be used for hexadecimal. Case is not important for any number or radix. Decimal is default, for example:

```
-AENTRY=0-0FFh-1FF
```

Did you forget the radix?

```
-AENTRY=0-0FFh-1FFh
```

## (447) bad load address "" in -A spec

(Linker)

The load address given in a -A specification is invalid: it should be a valid number, in decimal, octal, or hexadecimal radix. The radix is specified by a trailing O (for octal) or H for HEX. A leading 0x can also be used for hexadecimal. Case is not important for any number or radix. Decimal is default, for example:

```
-ACODE=0h-3ffffh/a000
```

Did you forget the radix?

```
-ACODE=0h-3ffffh/a000h
```

## (448) bad repeat count "" in -A spec

(Linker)

The repeat count given in a -A specification is invalid, for example:

```
-AENTRY=0-0FFhxf
```

Did you forget the radix?

```
-AENTRY=0-0FFhxfh
```

## (449) syntax error in -A spec: \*

(Linker)

The -A spec is invalid. A valid -A spec should be something like:

```
-AROM=1000h-1FFFh
```

## (450) psect "" was never defined, or is local (Linker)

This psect has been listed in a `-P` option, but is not defined in any module within the program. Alternatively, the psect is defined using the `local` psect flag, but with no class flag; and, so, cannot be linked to an address. Check the assembly list file to ensure that the psect exists and that it does not specify the `local` psect flag.

## (451) bad psect origin format in -P option (Linker)

The origin format in a `-p` option is not a validly formed decimal, octal, or HEX number, nor is it the name of an existing psect. A HEX number must have a trailing H, for example:

```
-pbss=f000
```

Did you forget the radix?

```
-pbss=f000h
```

## (452) bad "+" (minimum address) format in -P option (Linker)

The minimum address specification in the linker's `-p` option is badly formatted, for example:

```
-pbss=data+f000
```

Did you forget the radix?

```
-pbss=data+f000h
```

## (453) missing number after "%" in -P option (Linker)

The `%` operator in a `-p` option (for rounding boundaries) must have a number after it.

## (454) link and load address can't both be set to "." in -P option (Linker)

The link and load address of a psect have both been specified with a `dot` character. Only one of these addresses can be specified in this manner, for example:

```
-Pmypsect=1000h/.
```

```
-Pmypsect=./1000h
```

Both of these options are valid and equivalent. However, the following usage is ambiguous:

```
-Pmypsect=./.
```

What is the link or load address of this psect?

## (455) psect "" not relocated on 0x\* byte boundary (Linker)

This psect is not relocated on the required boundary. Check the relocatability of the psect and correct the `-p` option, if necessary.

## (456) psect "" not loaded on 0x\* boundary (Linker)

This psect has a relocatability requirement that is not met by the load address given in a `-p` option. For example, if a psect must be on a 4K byte boundary, you could not start it at 100H.

## (459) remove failed; error: \*, \* (Xstrip)

The creation of the output file failed when removing an intermediate file.



# Error and Warning Messages

---

**(460) rename failed; error: \*, \*** **(Xstrip)**

The creation of the output file failed when renaming an intermediate file.

**(461) can't create \* file ""** **(Assembler, Code Generator)**

This is an internal compiler error. Contact Microchip Technical Support with details.

**(464) missing key in avmap file** **(Linker)**

This is an internal compiler error. Contact Microchip Technical Support with details.

**(465) undefined symbol "" in FNBREAK record** **(Linker)**

The linker has found an undefined symbol in the `FNBREAK` record for a non-reentrant function. Contact Microchip Technical Support if this is not handwritten assembler code.

**(466) undefined symbol "" in FNINDIR record** **(Linker)**

The linker has found an undefined symbol in the `FNINDIR` record for a non-reentrant function. Contact Microchip Technical Support if this is not handwritten assembler code.

**(467) undefined symbol "" in FNADDR record** **(Linker)**

The linker has found an undefined symbol in the `FNADDR` record for a non-reentrant function. Contact Microchip Technical Support if this is not handwritten assembler code.

**(468) undefined symbol "" in FNCALL record** **(Linker)**

The linker has found an undefined symbol in the `FNCALL` record for a non-reentrant function. Contact Microchip Technical Support if this is not handwritten assembler code.

**(469) undefined symbol "" in FNROOT record** **(Linker)**

The linker has found an undefined symbol in the `FNROOT` record for a non-reentrant function. Contact Microchip Technical Support if this is not handwritten assembler code.

**(470) undefined symbol "" in FNSIZE record** **(Linker)**

The linker has found an undefined symbol in the `FNSIZE` record for a non-reentrant function. Contact Microchip Technical Support if this is not handwritten assembler code.

## (471) recursive function calls: (Linker)

These functions (or function) call each other recursively. One or more of these functions has statically allocated local variables (compiled stack). Either use the `reentrant` keyword (if supported with this compiler) or recode to avoid recursion, for example:

```
int test(int a)
{
    if(a == 5) {
        /* recursion cannot be supported by some compilers */
        return test(a++);
    }
    return 0;
}
```

## (472) non-reentrant function "" appears in multiple call graphs: rooted at "" and "" (Linker)

This function can be called from both main-line code and interrupt code. Use the `reentrant` keyword, if this compiler supports it, or recode to avoid using local variables or parameters, or duplicate the function, for example:

```
void interrupt my_isr(void)
{
    scan(6);    /* scan is called from an interrupt function */
}
void process(int a)
{
    scan(a);    /* scan is also called from main-line code */
}
```

## (473) function "" is not called from specified interrupt\_level (Linker)

The indicated function is never called from an interrupt function of the same interrupt level, for example:

```
#pragma interrupt_level 1
void foo(void)
{
    ...
}
#pragma interrupt_level 1
void interrupt bar(void)
{
    // this function never calls foo()
}
```

## (474) no psect specified for function variable/argument allocation (Linker)

The `FNCONF` assembler directive which specifies to the linker information regarding the auto/parameter block was never seen. This is supplied in the standard runtime files if necessary. This error can imply that the correct run-time startup module was not linked. Ensure you have used the `FNCONF` directive if the runtime startup module is hand-written.

## (475) conflicting FNCONF records (Linker)

The linker has seen two conflicting `FNCONF` directives. This directive should be specified only once, and is included in the standard runtime startup code which is normally linked into every program.

# Error and Warning Messages

---

**(476) fixup overflow referencing \* \* (location 0x\* (0x\*\*), size \*, value 0x\*)** **(Linker)**

The linker was asked to relocate (fixup) an item that would not fit back into the space after relocation. See the following error message (1356) for more information.

**(477) fixup overflow in expression (location 0x\* (0x\*\*), size \*, value 0x\*)** **(Linker)**

The linker was asked to relocate (fixup) an item that would not fit back into the space after relocation. See the following error message (1356) for more information.

**(478) \* range check failed (location 0x\* (0x\*\*), value 0x\* > limit 0x\*)** **(Linker)**

This is an internal compiler error. Contact Microchip Technical Support with details.

**(479) circular indirect definition of symbol ""** **(Linker)**

The specified symbol has been equated to an external symbol which, in turn, has been equated to the first symbol.

**(480) function signatures do not match: \* (\*): 0x\*/0x\*** **(Linker)**

The specified function has different signatures in different modules. This means it has been declared differently; i.e., it can have been prototyped in one module and not another. Check what declarations for the function are visible in the two modules specified and make sure they are compatible, for example:

```
extern int get_value(int in);
/* and in another module: */
/* this is different to the declaration */
int get_value(int in, char type)
{
```

**(481) common symbol "" psect conflict** **(Linker)**

A common symbol has been defined to be in more than one psect.

**(482) symbol "" is defined more than once in ""** **(Assembler)**

This symbol has been defined in more than one place. The assembler will issue this error if a symbol is defined more than once in the same module, for example:

```
_next:
    MOVE r0, #55
    MOVE [r1], r0
_next:      ; oops -- choose a different name
```

The linker will issue this warning if the symbol (C or assembler) was defined multiple times in different modules. The names of the modules are given in the error message. Note that C identifiers often have an *underscore* prepended to their name after compilation.

**(483) symbol "" can't be global** **(Linker)**

This is an internal compiler error. Contact Microchip Technical Support with details.

**(484) psect "\*" can't be in classes "\*" and "\*" (Linker)**

A psect cannot be in more than one class. This is either due to assembler modules with conflicting `class=` options to the PSECT directive, or use of the `-C` option to the linker, for example:

```
psect final,class=CODE
finish:
/* elsewhere: */
psect final,class=ENTRY
```

**(485) unknown "with" psect referenced by psect "\*" (Linker)**

The specified psect has been placed with a psect using the `psect with` flag. The psect it has been placed with does not exist, for example:

```
psect starttext,class=CODE,with=rest
; was that meant to be with text?
```

**(486) psect "\*" selector value redefined (Linker)**

The selector value for this psect has been defined more than once.

**(487) psect "\*" type redefined: \*/\* (Linker)**

This psect has had its type defined differently by different modules. This probably means you are trying to link incompatible object modules, i.e., linking 386 flat model code with 8086 real mode code.

**(488) psect "\*" memory space redefined: \*/\* (Linker)**

A global psect has been defined in two different memory spaces. Either rename one of the psects or, if they are the same psect, place them in the same memory space using the `space` psect flag, for example:

```
psect spdata,class=RAM,space=0
ds 6
; elsewhere:
psect spdata,class=RAM,space=1
```

**(489) psect "\*" memory delta redefined: \*/\* (Linker)**

A global psect has been defined with two different delta values, for example:

```
psect final,class=CODE,delta=2
finish:
; elsewhere:
psect final,class=CODE,delta=1
```

**(490) class "\*" memory space redefined: \*/\* (Linker)**

A class has been defined in two different memory spaces. Either rename one of the classes or, if they are the same class, place them in the same memory space.

**(491) can't find 0x\* words for psect "\*" in segment "\*" (Linker)**

One of the main tasks the linker performs is positioning the blocks (or psects) of code and data that is generated from the program into the memory available for the target device. This error indicates that the linker was unable to find an area of free memory large enough to accommodate one of the psects. The error message indicates the name of the psect that the linker was attempting to position and the segment name which is typically the name of a class which is defined with a linker `-A` option.

# Error and Warning Messages

---

[Section 5.15.2 “Compiler-Generated Psects”](#) lists each compiler-generated psect and what it contains. Typically psect names which are, or include, `text` relate to program code. Names such as `bss` or `data` refer to variable blocks. This error can be due to two reasons.

First, the size of the program or the program’s data has exceeded the total amount of space on the selected device. In other words, some part of your device’s memory has completely filled. If this is the case, then the size of the specified psect must be reduced.

The second cause of this message is when the total amount of memory needed by the psect being positioned is sufficient, but that this memory is fragmented in such a way that the largest contiguous block is too small to accommodate the psect. The linker is unable to split psects in this situation. That is, the linker cannot place part of a psect at one location and part somewhere else. Thus, the linker must be able to find a contiguous block of memory large enough for every psect. If this is the cause of the error, then the psect must be split into smaller psects if possible.

To find out what memory is still available, generate and look in the map file, see [Section 4.8.7 “-M: Generate Map File”](#) for information on how to generate a map file. Search for the string `UNUSED ADDRESS RANGES`. Under this heading, look for the name of the segment specified in the error message. If the name is not present, then all the memory available for this psect has been allocated. If it is present, there will be one address range specified under this segment for each free block of memory. Determine the size of each block and compare this with the number of words specified in the error message.

Psects containing code can be reduced by using all the compiler’s optimizations, or restructuring the program. If a code psect must be split into two or more small psects, this requires splitting a function into two or more smaller functions (which can call each other). These functions can need to be placed in new modules.

Psects containing data can be reduced when invoking the compiler optimizations, but the effect is less dramatic. The program can need to be rewritten so that it needs less variables. If the default linker options must be changed, this can be done indirectly through the driver using the driver `-L-` option, see [Section 4.8.6 “-L-: Adjust Linker Options Directly”](#). [Section 4.8.7 “-M: Generate Map File”](#) has information on interpreting the map file’s call graph if the compiler you are using uses a compiled stack. (If the string `Call graph:` is not present in the map file, then the compiled code uses a hardware stack.) If a data psect needs to be split into smaller psects, the definitions for variables will need to be moved to new modules or more evenly spread in the existing modules. Memory allocation for `auto` variables is entirely handled by the compiler. Other than reducing the number of these variables used, the programmer has little control over their operation. This applies whether the compiled code uses a hardware or compiled stack.

For example, after receiving the message:

```
Can't find 0x34 words (0x34 withtotal) for psect text
  in segment CODE (error)
```

look in the map file for the ranges of unused memory.

```
UNUSED ADDRESS RANGES
CODE                00000244-0000025F
                   00001000-0000102f
RAM                 00300014-00301FFB
```

In the `CODE` segment, there is `0x1c` (`0x25f-0x244+1`) bytes of space available in one block and `0x30` available in another block. Neither of these are large enough to accommodate the psect `text` which is `0x34` bytes long. Notice, however, that the total amount of memory available is larger than `0x34` bytes.

**(492) attempt to position absolute psect "\*" is illegal** **(Linker)**

This psect is absolute and should not have an address specified in a `-P` option. Either remove the `abs` psect flag, or remove the `-P` linker option.

**(493) origin of psect "\*" is defined more than once** **(Linker)**

The origin of this psect is defined more than once. There is most likely more than one `-P` linker option specifying this psect.

**(494) bad -P format "\*/\*\*"** **(Linker)**

The `-P` option given to the linker is malformed. This option specifies placement of a psect, for example:

```
-Ptext=10g0h
```

Possibly, you meant:

```
-Ptext=10f0h
```

**(495) use of both "with=" and "INCLASS/INCLASS" allocation is illegal** **(Linker)**

It is not legal to specify both the link and location of a psect as within a class, when that psect was also defined using a `with` psect flag.

**(497) psect "\*" exceeds max size: \*h > \*h** **(Linker)**

The psect has more bytes in it than the maximum allowed as specified using the `size` psect flag.

**(498) psect "\*" exceeds address limit: \*h > \*h** **(Linker)**

The maximum address of the psect exceeds the limit placed on it using the `limit` psect flag. Either the psect needs to be linked at a different location or there is too much code/data in the psect.

**(499) undefined symbol:** **(Assembler, Linker)**

The symbol following is undefined at link time. This could be due to spelling error, or failure to link an appropriate module.

# Error and Warning Messages

---

## MESSAGES 500-749

### **(500) undefined symbols:** **(Linker)**

A list of symbols follows that were undefined at link time. These errors could be due to spelling error, or failure to link an appropriate module.

### **(501) program entry point is defined more than once** **(Linker)**

There is more than one entry point defined in the object files given the linker. End entry point is specified after the `END` directive. The runtime startup code defines the entry point, for example:

```
powerup:
  goto start
  END powerup ; end of file and define entry point
; other files that use END should not define another entry point
```

### **(502) incomplete \* record body: length = \*** **(Linker)**

An object file contained a record with an illegal size. This probably means the file is truncated or not an object file. Contact Microchip Technical Support with details.

### **(503) ident records do not match** **(Linker)**

The object files passed to the linker do not have matching ident records. This means they are for different device types.

### **(504) object code version is greater than \*.\*** **(Linker)**

The object code version of an object module is higher than the highest version the linker is known to work with. Check that you are using the correct linker. Contact Microchip Technical Support if you have not patched the linker.

### **(505) no end record found in object file** **(Linker)**

An object file did not contain an end record. This probably means the file is corrupted or not an object file. Contact Microchip Technical Support if the object file was generated by the compiler.

### **(506) object file record too long: \*\*** **(Linker)**

This is an internal compiler error. Contact Microchip Technical Support with details.

### **(507) unexpected end of file in object file** **(Linker)**

This is an internal compiler error. Contact Microchip Technical Support with details.

### **(508) relocation offset (\*) out of range 0..\*-\*-1** **(Linker)**

This is an internal compiler error. Contact Microchip Technical Support with details.

### **(509) illegal relocation size: \*** **(Linker)**

There is an error in the object code format read by the linker. This either means you are using a linker that is out of date, or that there is an internal error in the assembler or linker. Contact Microchip Technical Support with details if the object file was created by the compiler.

# MPLAB® XC8 C Compiler User's Guide

---

- (510) complex relocation not supported for -R or -L options** *(Linker)*  
The linker was given a `-R` or `-L` option with file that contain complex relocation.
- (511) bad complex range check** *(Linker)*  
This is an internal compiler error. Contact Microchip Technical Support with details.
- (512) unknown complex operator 0x\*** *(Linker)*  
This is an internal compiler error. Contact Microchip Technical Support with details.
- (513) bad complex relocation** *(Linker)*  
The linker has been asked to perform complex relocation that is not syntactically correct. Probably means an object file is corrupted.
- (514) illegal relocation type: \*** *(Linker)*  
An object file contained a relocation record with an illegal relocation type. This probably means the file is corrupted or not an object file. Contact Microchip Technical Support with details if the object file was created by the compiler.
- (515) unknown symbol type \*** *(Linker)*  
This is an internal compiler error. Contact Microchip Technical Support with details.
- (516) text record has bad length: \*.\*-( $*+1$ ) < 0** *(Linker)*  
This is an internal compiler error. Contact Microchip Technical Support with details.
- (520) function "" is never called** *(Linker)*  
This function is never called. This cannot represent a problem, but space could be saved by removing it. If you believe this function should be called, check your source code. Some assembler library routines are never called, although they are actually execute. In this case, the routines are linked in a special sequence so that program execution falls through from one routine to the next.
- (521) call depth exceeded by function ""** *(Linker)*  
The call graph shows that functions are nested to a depth greater than specified.
- (522) library "" is badly ordered** *(Linker)*  
This library is badly ordered. It will still link correctly, but it will link faster if better ordered.
- (523) argument to -W option (\*) illegal and ignored** *(Linker)*  
The argument to the linker option `-w` is out of range. This option controls two features. For warning levels, the range is -9 to 9. For the map file width, the range is greater than or equal to 10.
- (524) unable to open list file "": \*** *(Linker)*  
The named list file could not be opened. The linker would be trying to fixup the list file so that it will contain absolute addresses. Ensure that an assembler list file was generated during the compilation stage. Alternatively, remove the assembler list file generation option from the link step.



# Error and Warning Messages

---

- (525) too many address (memory) spaces; space (\*) ignored** *(Linker)*  
The limit to the number of address spaces (specified with the `PSECT` assembler directive) is currently 16.
- (526) psect "" not specified in -P option (first appears in "")** *(Linker)*  
This psect was not specified in a `-P` or `-A` option to the linker. It has been linked at the end of the program, which is probably not where you wanted it.
- (528) no start record; entry point defaults to zero** *(Linker)*  
None of the object files passed to the linker contained a start record. The start address of the program has been set to zero. This can be harmless, but it is recommended that you define a start address in your startup module by using the `END` directive.
- (529) usage: objtohex [-Ssymfile] [object-file [HEX-file]]** *(Objtohex)*  
Improper usage of the command-line tool `objtohex`. If you are not invoking this tool directly, this is an internal compiler error, and you should contact Microchip Technical Support with details.
- (593) can't find 0x\* words (0x\* withtotal) for psect "" in segment ""** *(Linker)*  
See message (491).
- (594) undefined symbol:** *(Linker)*  
The symbol following is undefined at link time. This could be due to spelling error, or failure to link an appropriate module.
- (595) undefined symbols:** *(Linker)*  
A list of symbols follows that were undefined at link time. These errors could be due to spelling error, or failure to link an appropriate module.
- (596) segment "" (\*-\*) overlaps segment "" (\*-\*)** *(Linker)*  
The named segments have overlapping code or data. Check the addresses being assigned by the `-P` linker option.
- (599) No psect classes given for COFF write** *(Cromwell)*  
`CROMWELL` requires that the program memory psect classes be specified to produce a COFF file. Ensure that you are using the `-N` option.
- (600) No chip arch given for COFF write** *(Cromwell)*  
`CROMWELL` requires that the chip architecture be specified to produce a COFF file. Ensure that you are using the `-P` option.
- (601) Unknown chip arch "" for COFF write** *(Cromwell)*  
The chip architecture specified for producing a COFF file isn't recognized by `CROMWELL`. Ensure that you are using the `-P` option, and that the architecture is correctly specified.
- (602) null file format name** *(Cromwell)*  
The `-I` or `-O` option to `CROMWELL` must specify a file format.

# MPLAB® XC8 C Compiler User's Guide

---

- (603) ambiguous file format name "\*\*\*** **(Cromwell)**
- The input or output format specified to CROMWELL is ambiguous. These formats are specified with the `-i` key and `-o` key options respectively.
- (604) unknown file format name "\*\*\*** **(Cromwell)**
- The output format specified to CROMWELL is unknown, for example:
- ```
cromwell -m -P16F877 main.HEX main.sym -ocot
```
- and output file type of `cot`, did you mean `cof`?
- (605) did not recognize format of input file** **(Cromwell)**
- The input file to CROMWELL is required to have a Cromwell map file (CMF), COD, Intel HEX, Motorola HEX, COFF, OMF51, ELF, UBROF or HI-TECH format.
- (606) inconsistent symbol tables** **(Cromwell)**
- This is an internal compiler error. Contact Microchip Technical Support with details.
- (607) inconsistent line number tables** **(Cromwell)**
- This is an internal compiler error. Contact Microchip Technical Support with details.
- (608) bad path specification** **(Cromwell)**
- This is an internal compiler error. Contact Microchip Technical Support with details.
- (609) missing device spec after -P** **(Cromwell)**
- The `-p` option to CROMWELL must specify a device name.
- (610) missing psect classes after -N** **(Cromwell)**
- CROMWELL requires that the `-N` option be given a list of the names of psect classes.
- (611) too many input files** **(Cromwell)**
- Too many input files have been specified to be converted by CROMWELL.
- (612) too many output files** **(Cromwell)**
- Too many output file formats have been specified to CROMWELL.
- (613) no output file format specified** **(Cromwell)**
- The output format must be specified to CROMWELL.
- (614) no input files specified** **(Cromwell)**
- CROMWELL must have an input file to convert.
- (616) option -Cbaseaddr is illegal with options -R or -L** **(Linker)**
- The linker option `-Cbaseaddr` cannot be used in conjunction with either the `-R` or `-L` linker options.

# Error and Warning Messages

---

- (618) error reading COD file data** *(Cromwell)*  
An error occurred reading the input COD file. Confirm the spelling and path of the file specified on the command line.
- (619) I/O error reading symbol table** *(Cromwell)*  
The COD file has an invalid format in the specified record.
- (620) filename index out of range in line number record** *(Cromwell)*  
The COD file has an invalid value in the specified record.
- (621) error writing ELF/DWARF section "" on ""** *(Cromwell)*  
An error occurred writing the indicated section to the given file. Confirm the spelling and path of the file specified on the command line.
- (622) too many type entries** *(Cromwell)*  
This is an internal compiler error. Contact Microchip Technical Support with details.
- (623) bad class in type hashing** *(Cromwell)*  
This is an internal compiler error. Contact Microchip Technical Support with details.
- (624) bad class in type compare** *(Cromwell)*  
This is an internal compiler error. Contact Microchip Technical Support with details.
- (625) too many files in COFF file** *(Cromwell)*  
This is an internal compiler error. Contact Microchip Technical Support with details.
- (626) string lookup failed in COFF: get\_string()** *(Cromwell)*  
This is an internal compiler error. Contact Microchip Technical Support with details.
- (627) missing "" in SDB file "" line \* column \*** *(Cromwell)*  
This is an internal compiler error. Contact Microchip Technical Support with details.
- (629) bad storage class "" in SDB file "" line \* column \*** *(Cromwell)*  
This is an internal compiler error. Contact Microchip Technical Support with details.
- (630) invalid syntax for prefix list in SDB file ""** *(Cromwell)*  
This is an internal compiler error. Contact Microchip Technical Support with details.
- (631) syntax error at token "" in SDB file "" line \* column \*** *(Cromwell)*  
This is an internal compiler error. Contact Microchip Technical Support with details.
- (632) can't handle address size (\*)** *(Cromwell)*  
This is an internal compiler error. Contact Microchip Technical Support with details.

# MPLAB® XC8 C Compiler User's Guide

---

- (633) unknown symbol class (\*)** **(Cromwell)**  
`CROMWELL` has encountered a symbol class in the symbol table of a COFF, Microchip COFF, or ICOFF file which it cannot identify.
- (634) error dumping ""** **(Cromwell)**  
Either the input file to `CROMWELL` is of an unsupported type or that file cannot be dumped to the screen.
- (635) invalid HEX file "" on line \*** **(Cromwell)**  
The specified HEX file contains an invalid line. Contact Microchip Technical Support if the HEX file was generated by the compiler.
- (636) error in Intel HEX file "" on line \*** **(Cromwell, Hexmate)**  
An error was found at the specified line in the specified Intel HEX file. The HEX file may be corrupt.
- (637) unknown prefix "" in SDB file ""** **(Cromwell)**  
This is an internal compiler warning. Contact Microchip Technical Support with details.
- (638) version mismatch: 0x\* expected** **(Cromwell)**  
The input Microchip COFF file wasn't produced using `CROMWELL`.
- (639) zero bit width in Microchip optional header** **(Cromwell)**  
The optional header in the input Microchip COFF file indicates that the program or data memory spaces are zero bits wide.
- (668) prefix list did not match any SDB types** **(Cromwell)**  
This is an internal compiler error. Contact Microchip Technical Support with details.
- (669) prefix list matched more than one SDB type** **(Cromwell)**  
This is an internal compiler error. Contact Microchip Technical Support with details.
- (670) bad argument to -T** **(Clist)**  
The argument to the `-T` option to specify tab size was not present or correctly formed. The option expects a decimal integer argument.
- (671) argument to -T should be in range 1 to 64** **(Clist)**  
The argument to the `-T` option to specify tab size was not in the expected range. The option expects a decimal integer argument ranging from 1 to 64 inclusive.
- (673) missing filename after \* option** **(Objtohex)**  
The indicated option requires a valid file name. Ensure that the filename argument supplied to this option exists and is spelt correctly.
- (674) too many references to ""** **(Cref)**  
This is an internal compiler error. Contact Microchip Technical Support with details.

# Error and Warning Messages

---

- (677) set\_fact\_bit on pic17!** *(Code Generator)*  
This is an internal compiler error. Contact Microchip Technical Support with details.
- (678) case 55 on pic17!** *(Code Generator)*  
This is an internal compiler error. Contact Microchip Technical Support with details.
- (679) unknown extraspecial: \*** *(Code Generator)*  
This is an internal compiler error. Contact Microchip Technical Support with details.
- (680) bad format for -P option** *(Code Generator)*  
This is an internal compiler error. Contact Microchip Technical Support with details.
- (681) bad common spec in -P option** *(Code Generator)*  
This is an internal compiler error. Contact Microchip Technical Support with details.
- (682) this architecture is not supported by the PICC™ Lite compiler** *(Code Generator)*  
A target device other than baseline, mid-range or highend was specified. This compiler only supports devices from these architecture families.
- (683) bank 1 variables are not supported by the PICC Lite compiler** *(Code Generator)*  
A variable with an absolute address located in bank 1 was detected. This compiler does not support code generation of variables in this bank.
- (684) bank 2 and 3 variables are not supported by the PICC Lite compiler** *(Code Generator)*  
A variable with an absolute address located in bank 2 or 3 was detected. This compiler does not support code generation of variables in these banks.
- (685) bad putwsize()** *(Code Generator)*  
This is an internal compiler error. Contact Microchip Technical Support with details.
- (686) bad switch size (\*)** *(Code Generator)*  
This is an internal compiler error. Contact Microchip Technical Support with details.
- (687) bad pushreg ""** *(Code Generator)*  
This is an internal compiler error. Contact Microchip Technical Support with details.
- (688) bad popreg ""** *(Code Generator)*  
This is an internal compiler error. Contact Microchip Technical Support with details.
- (689) unknown predicate ""** *(Code Generator)*  
This is an internal compiler error. Contact Microchip Technical Support with details.

## **(690) interrupt function requires address** **(Code Generator)**

The high end PIC devices support multiple interrupts. An @ *address* is required with the interrupt definition to indicate with which vector this routine is associated, for example:

```
void interrupt isr(void) @ 0x10
{
    /* isr code goes here */
}
```

This construct is not required for mid-range PIC devices.

## **(691) interrupt functions not implemented for 12 bit PIC MCU** **(Code Generator)**

The 12-bit range of PIC MCU processors do not support interrupts.

## **(692) more than one interrupt level is associated with the interrupt function ""** **(Code Generator)**

Only one interrupt level can be associated with an `interrupt` function. Check to ensure that only one `interrupt_level` pragma has been used with the function specified. This pragma can be used more than once on main-line functions that are called from `interrupt` functions. For example:

```
#pragma interrupt_level 0
#pragma interrupt_level 1 /* oops -- which is it to be: 0 or 1? */
void interrupt isr(void)
{
```

## **(693) 0 (default) or 1 are the only acceptable interrupt levels for this function** **(Code Generator)**

The only possible interrupt levels are 0 or 1. Check to ensure that all `interrupt_level` pragmas use these levels.

```
#pragma interrupt_level 2 /* oops -- only 0 or 1 */
void interrupt isr(void)
{
    /* isr code goes here */
}
```

## **(694) no interrupt strategy available** **(Code Generator)**

The device does not support saving and subsequent restoring of registers during an interrupt service routine.

## **(695) duplicate case label (\*)** **(Code Generator)**

There are two case labels with the same value in this `switch` statement, for example:

```
switch(in) {
case '0': /* if this is case '0'... */
    b++;
    break;
case '0': /* then what is this case? */
    b--;
    break;
}
```

## **(696) out-of-range case label (\*)** **(Code Generator)**

This case label is not a value that the controlling expression can yield, and thus this label will never be selected.

# Error and Warning Messages

---

**(697) non-constant case label** **(Code Generator)**

A `case` label in this `switch` statement has a value which is not a constant.

**(698) bit variables must be global or static** **(Code Generator)**

A `bit` variable cannot be of type `auto`. If you require a `bit` variable with scope local to a block of code or function, qualify it `static`, for example:

```
bit proc(int a)
{
    bit bb;          /* oops -- this should be: static bit bb; */
    bb = (a > 66);
    return bb;
}
```

**(699) no case labels in switch** **(Code Generator)**

There are no `case` labels in this `switch` statement, for example:

```
switch(input) {
} /* there is nothing to match the value of input */
```

**(700) truncation of enumerated value** **(Code Generator)**

An enumerated value larger than the maximum value supported by this compiler was detected and has been truncated, for example:

```
enum { ZERO, ONE, BIG=0x99999999 } test_case;
```

**(701) unreasonable matching depth** **(Code Generator)**

This is an internal compiler error. Contact Microchip Technical Support with details.

**(702) regused(): bad arg to G** **(Code Generator)**

This is an internal compiler error. Contact Microchip Technical Support with details.

**(703) bad GN** **(Code Generator)**

This is an internal compiler error. Contact Microchip Technical Support with details.

**(704) bad RET\_MASK** **(Code Generator)**

This is an internal compiler error. Contact Microchip Technical Support with details.

**(705) bad which (\*) after I** **(Code Generator)**

This is an internal compiler error. Contact Microchip Technical Support with details.

**(706) bad which in expand()** **(Code Generator)**

This is an internal compiler error. Contact Microchip Technical Support with details.

**(707) bad SX** **(Code Generator)**

This is an internal compiler error. Contact Microchip Technical Support with details.

**(708) bad mod "+" for how = ""** **(Code Generator)**

This is an internal compiler error. Contact Microchip Technical Support with details.

# MPLAB® XC8 C Compiler User's Guide

---

**(709) metaregister "" can't be used directly** **(Code Generator)**

This is an internal compiler error. Contact Microchip Technical Support with details.

**(710) bad U usage** **(Code Generator)**

This is an internal compiler error. Contact Microchip Technical Support with details.

**(711) bad how in expand()** **(Code Generator)**

This is an internal compiler error. Contact Microchip Technical Support with details.

**(712) can't generate code for this expression** **(Code Generator)**

This error indicates that a C expression is too difficult for the code generator to actually compile. For successful code generation, the code generator must know how to compile an expression and there must be enough resources (i.e., registers or temporary memory locations) available. Simplifying the expression, i.e., using a temporary variable to hold an intermediate result, can often bypass this situation.

This error can also be issued if the code being compiled is unusual. For example, code which writes to a const-qualified object is illegal and will result in warning messages, but the code generator can unsuccessfully try to produce code to perform the write.

This error can also result from an attempt to redefine a function that uses the `intrinsic` pragma.

**(713) bad initialization list** **(Code Generator)**

This is an internal compiler error. Contact Microchip Technical Support with details.

**(714) bad intermediate code** **(Code Generator)**

This is an internal compiler error. Contact Microchip Technical Support with details.

**(715) bad pragma ""** **(Code Generator)**

The code generator has been passed a `pragma` directive that it does not understand. This implies that the pragma you have used is not implemented for the target device.

**(716) bad argument to -M option ""** **(Code Generator)**

The code generator has been passed a `-M` option that it does not understand. This should not happen if it is being invoked by a standard compiler driver.

**(718) incompatible intermediate code version; should be \*.\*** **(Code Generator)**

The intermediate code file produced by P1 is not the correct version for use with this code generator. This is either that incompatible versions of one or more compilers have been installed in the same directory, or a temporary file error has occurred leading to corruption of a temporary file. Check the setting of the `TEMP` environment variable. If it refers to a long path name, change it to something shorter. Contact Microchip Technical Support with details if required.

**(720) multiple free: \*** **(Code Generator)**

This is an internal compiler error. Contact Microchip Technical Support with details.



# Error and Warning Messages

---

## **(721) element count must be constant expression** **(Code Generator)**

The expression that determines the number of elements in an array must be a constant expression. Variables qualified as `const` do not form such an expression.

```
const unsigned char mCount = 5;
int mDeadtimeArr[mCount]; // oops -- the size cannot be a variable
```

## **(722) bad variable syntax in intermediate code** **(Code Generator)**

This is an internal compiler error. Contact Microchip Technical Support with details.

## **(723) function definitions nested too deep** **(Code Generator)**

This error is unlikely to happen with C code, because C cannot have nested functions! Contact Microchip Technical Support with details.

## **(724) bad op (\*) in revlog()** **(Code Generator)**

This is an internal compiler error. Contact Microchip Technical Support with details.

## **(726) bad op "\*" in uconval()** **(Code Generator)**

This is an internal compiler error. Contact Microchip Technical Support with details.

## **(727) bad op "\*" in bconfloat()** **(Code Generator)**

This is an internal code generator error. Contact Microchip Technical Support with details.

## **(728) bad op "\*" in confloat()** **(Code Generator)**

This is an internal compiler error. Contact Microchip Technical Support with details.

## **(729) bad op "\*" in conval()** **(Code Generator)**

This is an internal compiler error. Contact Microchip Technical Support with details.

## **(730) bad op "\*" **(Code Generator)****

This is an internal compiler error. Contact Microchip Technical Support with details.

## **(731) expression error with reserved word** **(Code Generator)**

This is an internal compiler error. Contact Microchip Technical Support with details.

## **(732) initialization of bit types is illegal** **(Code Generator)**

Variables of type `bit` cannot be initialized, for example:

```
bit b1 = 1; /* oops! b1 must be assigned after its definition */
```

## **(733) bad string "\*" in pragma "psect" **(Code Generator)****

The code generator has been passed a `pragma psect` directive that has a badly formed string, for example:

```
#pragma psect text /* redirect text psect into what? */
```

Possibly, you meant something like:

```
#pragma psect text=special_text
```

**(734) too many "psect" pragmas** **(Code Generator)**

Too many `#pragma psect` directives have been used.

**(735) bad string "" in pragma "stack\_size"** **(Code Generator)**

The argument to the `stack_size` pragma is malformed. This pragma must be followed by a number representing the maximum allowed stack size.

**(737) unknown argument "" to pragma "switch"** **(Code Generator)**

The `#pragma switch` directive has been used with an invalid switch code generation method. Possible arguments are: `auto`, `simple` and `direct`.

**(739) error closing output file** **(Code Generator)**

The compiler detected an error when closing a file. Contact Microchip Technical Support with details.

**(740) zero dimension array is illegal** **(Code Generator)**

The code generator has been passed a declaration that results in an array having a zero dimension.

**(741) bitfield too large (\* bits)** **(Code Generator)**

The maximum number of bits in a bit-field is 8, the same size as the storage unit width.

```
struct {
    unsigned flag : 1;
    unsigned value : 12; /* oops -- that's larger than 8 bits wide */
    unsigned cont : 6;
} object;
```

**(742) function "" argument evaluation overlapped** **(Linker)**

A function call involves arguments which overlap between two functions. This could occur with a call like:

```
void fn1(void)
{
    fn3( 7, fn2(3), fn2(9)); /* Offending call */
}
char fn2(char fred)
{
    return fred + fn3(5,1,0);
}
char fn3(char one, char two, char three)
{
    return one+two+three;
}
```

where `fn1` is calling `fn3`, and two arguments are evaluated by calling `fn2`, which in turn calls `fn3`. The program structure should be modified to prevent this type of call sequence.

**(743) divide by zero** **(Code Generator)**

An expression involving a division by zero has been detected in your code.

# Error and Warning Messages

---

**(744) static object "" has zero size** **(Code Generator)**

A static object has been declared, but has a size of zero.

**(745) nodecount = \*** **(Code Generator)**

This is an internal compiler error. Contact Microchip Technical Support with details.

**(746) object "" qualified const but not initialized** **(Code Generator)**

An object has been qualified as `const`, but there is no initial value supplied at the definition. As this object cannot be written by the C program, this can imply the initial value was accidentally omitted.

**(747) unrecognized option "" to -Z** **(Code Generator)**

This is an internal compiler error. Contact Microchip Technical Support with details.

**(748) variable "" possibly used before being assigned a value** **(Code Generator)**

This variable has possibly been used before it was assigned a value. Because it is an `auto` variable, this will result in it having an unpredictable value, for example:

```
void main(void)
{
    int a;
    if(a)          /* oops -- 'a' has never been assigned a value */
        process();
}
```

**(749) unknown register name "" used with pragma** **(Linker)**

This is an internal compiler error. Contact Microchip Technical Support with details.

## MESSAGES 750-999

### (750) constant operand to || or &&

(Code Generator)

One operand to the logical operators || or && is a constant. Check the expression for missing or badly placed parentheses. This message can also occur if the global optimizer is enabled and one of the operands is an `auto` or `static` local variable whose value has been tracked by the code generator, for example:

```
{
int a;
a = 6;
if(a || b) /* a is 6, therefore this is always true */
    b++;
```

### (751) arithmetic overflow in constant expression

(Code Generator)

A constant expression has been evaluated by the code generator that has resulted in a value that is too big for the type of the expression. The most common code to trigger this warning is assignments to `signed` data types. For example:

```
signed char c;
c = 0xFF;
```

As a `signed` 8-bit quantity, `c` can only be assigned values -128 to 127. The constant is equal to 255 and is outside this range. If you mean to set all bits in this variable, then use either of:

```
c = ~0x0;
c = -1;
```

which sets all the bits in the variable, regardless of variable size, and without warning.

This warning can also be triggered by intermediate values overflowing. For example:

```
unsigned int i; /* assume ints are 16 bits wide */
i = 240 * 137; /* this should be okay, right? */
```

A quick check with your calculator reveals that `240 * 137` is 32880 which can easily be stored in an `unsigned int`, but a warning is produced. Why? Because 240 and 137 are both `signed int` values. Therefore the result of the multiplication must also be a `signed int` value, but a `signed int` cannot hold the value 32880. (Both operands are constant values so the code generator can evaluate this expression at compile time, but it must do so following all the ANSI C rules.) The following code forces the multiplication to be performed with an `unsigned` result:

```
i = 240u * 137; /* force at least one operand
                to be unsigned */
```

### (752) conversion to shorter data type

(Code Generator)

Truncation can occur in this expression as the `lvalue` is of shorter type than the `rvalue`, for example:

```
char a;
int b, c;
a = b + c; /* int to char conversion
           can result in truncation */
```

## **(753) undefined shift (\* bits)**

**(Code Generator)**

An attempt has been made to shift a value by a number of bits equal to or greater than the number of bits in the data type. This will produce an undefined result on many processors. This is non-portable code and is flagged as having undefined results by the C Standard, for example:

```
int input;
input <<= 33; /* oops -- that shifts the entire value out */
```

## **(754) bitfield comparison out of range**

**(Code Generator)**

This is the result of comparing a bit-field with a value when the value is out of range of the bit-field. That is, comparing a 2-bit bit-field to the value 5 will never be true as a 2-bit bit-field has a range from 0 to 3. For example:

```
struct {
    unsigned mask : 2; /* mask can hold values 0 to 3 */
} value;
int compare(void)
{
    return (value.mask == 6); /* test can
}
```

## **(755) divide by zero**

**(Code Generator)**

A constant expression that was being evaluated involved a division by zero, for example:

```
a /= 0; /* divide by 0: was this what you were intending */
```

## (757) constant conditional branch

(Code Generator)

A conditional branch (generated by an `if`, `for`, `while` statement etc.) always follows the same path. This will be some sort of comparison involving a variable and a constant expression. For the code generator to issue this message, the variable must have local scope (either `auto` or `static` local) and the global optimizer must be enabled, possibly at higher level than 1, and the warning level threshold can need to be lower than the default level of 0.

The global optimizer keeps track of the contents of local variables for as long as is possible during a function. For C code that compares these variables to constants, the result of the comparison can be deduced at compile time and the output code hard coded to avoid the comparison, for example:

```
{
    int a, b;
    a = 5;
    /* this can never be false;
       always perform the true statement */
    if(a == 5)
        b = 6;
```

will produce code that sets `a` to 5, then immediately sets `b` to 6.

No code will be produced for the comparison `if(a == 5)`. If `a` was a global variable, it can be that other functions (particularly interrupt functions) can modify it and so tracking the variable cannot be performed.

This warning can indicate more than an optimization made by the compiler. It can indicate an expression with missing or badly placed parentheses, causing the evaluation to yield a value different to what you expected.

This warning can also be issued because you have written something like `while(1)`. To produce an infinite loop, use `for(;;)`.

A similar situation arises with `for` loops, for example:

```
{
    int a, b;
    /* this loop must iterate at least once */
    for(a=0; a!=10; a++)
        b = func(a);
```

In this case the code generator can again pick up that `a` is assigned the value 0, then immediately checked to see if it is equal to 10. Because `a` is modified during the `for` loop, the comparison code cannot be removed, but the code generator will adjust the code so that the comparison is not performed on the first pass of the loop; only on the subsequent passes. This cannot reduce code size, but it will speed program execution.

# Error and Warning Messages

---

## (758) constant conditional branch: possible use of "=" instead of "==" (Code Generator)

There is an expression inside an `if` or other conditional construct, where a constant is being assigned to a variable. This can mean you have inadvertently used an assignment `=` instead of a compare `==`, for example:

```
int a, b;
/* this can never be false;
   always perform the true statement */
if(a = 4)
    b = 6;
```

will assign the value 4 to `a`, then `,` as the value of the assignment is always true, the comparison can be omitted and the assignment to `b` always made. Did you mean:

```
/* this can never be false;
   always perform the true statement */
if(a == 4)
    b = 6;
```

which checks to see if `a` is equal to 4.

## (759) expression generates no code (Code Generator)

This expression generates no output code. Check for things like leaving off the parentheses in a function call, for example:

```
int fred;
fred; /* this is valid, but has no effect at all */
```

Some devices require that special function register need to be read to clear hardware flags. To accommodate this, in some instances the code generator *does* produce code for a statement which only consists of a variable ID. This can happen for variables which are qualified as `volatile`. Typically the output code will read the variable, but not do anything with the value read.

## (760) portion of expression has no effect (Code Generator)

Part of this expression has no side effects, and no effect on the value of the expression, for example:

```
int a, b, c;
a = b,c; /* "b" has no effect,
          was that meant to be a comma? */
```

## (761) sizeof yields 0 (Code Generator)

The code generator has taken the size of an object and found it to be zero. This almost certainly indicates an error in your declaration of a pointer; i.e., you can have declared a pointer to a zero length array. In general, pointers to arrays are of little use. If you require a pointer to an array of objects of unknown length, you only need a pointer to a single object that can then be indexed or incremented.

## (762) constant truncated when assigned to bitfield (Code Generator)

A constant value is too large for a bitfield structure member to which it is being assigned, for example:

```
struct INPUT {
    unsigned a : 3;
    unsigned b : 5;
} input_grp;
input_grp.a = 0x12; /* oops -- 0x12 cannot fit into a 3-bit wide
object */
```

## (763) constant left operand to "? : " operator (Code Generator)

The left operand to a conditional operator ? is constant, thus the result of the tertiary operator ? : will always be the same, for example:

```
a = 8 ? b : c; /* this is the same as saying a = b; */
```

## (764) mismatched comparison (Code Generator)

A comparison is being made between a variable or expression and a constant value which is not in the range of possible values for that expression, for example:

```
unsigned char c;  
if(c > 300) /* oops -- how can this be true? */  
    close();
```

## (765) degenerate unsigned comparison (Code Generator)

There is a comparison of an unsigned value with zero, which will always be true or false, for example:

```
unsigned char c;  
if(c >= 0)
```

will always be true, because an unsigned value can never be less than zero.

## (766) degenerate signed comparison (Code Generator)

There is a comparison of a signed value with the most negative value possible for this type, such that the comparison will always be true or false, for example:

```
char c;  
if(c >= -128)
```

will always be true, because an 8 bit signed char has a maximum negative value of -128.

## (767) constant truncated to bitfield width (Code Generator)

A constant value is too large for a bit-field structure member on which it is operating, for example:

```
struct INPUT {  
    unsigned a : 3;  
    unsigned b : 5;  
} input_grp;  
input_grp.a |= 0x13; /* oops -- 0x13 too large for 3-bit wide object */
```

## (768) constant relational expression (Code Generator)

There is a relational expression that will always be true or false. This, for example, can be the result of comparing an unsigned number with a negative value; or comparing a variable with a value greater than the largest number it can represent, for example:

```
unsigned int a;  
if(a == -10) /* if a is unsigned, how can it be -10? */  
    b = 9;
```

## (769) no space for macro definition (Assembler)

The assembler has run out of memory.



# Error and Warning Messages

---

- (772) include files nested too deep** **(Assembler)**  
Macro expansions and include file handling have filled up the assembler's internal stack. The maximum number of open macros and include files is 30.
- (773) macro expansions nested too deep** **(Assembler)**  
Macro expansions in the assembler are nested too deep. The limit is 30 macros and include files nested at one time.
- (774) too many macro parameters** **(Assembler)**  
There are too many macro parameters on this macro definition.
- (776) can't allocate space for object "" (offs: \*)** **(Assembler)**  
The assembler has run out of memory.
- (777) can't allocate space for opnd structure within object "" (offs: \*)** **(Assembler)**  
The assembler has run out of memory.
- (780) too many psects defined** **(Assembler)**  
There are too many psects defined! Boy, what a program!
- (781) can't enter abs psect** **(Assembler)**  
This is an internal compiler error. Contact Microchip Technical Support with details.
- (782) REMSYM error** **(Assembler)**  
This is an internal compiler error. Contact Microchip Technical Support with details.
- (783) "with" psects are cyclic** **(Assembler)**  
If Psect A is to be placed "with" Psect B, and Psect B is to be placed "with" Psect A, there is no hierarchy. The `with` flag is an attribute of a psect and indicates that this psect must be placed in the same memory page as the specified psect.  
Remove a `with` flag from one of the psect declarations. Such an assembler declaration can look like:  

```
psect my_text,local,class=CODE,with=basecode
```

which will define a psect called `my_text` and place this in the same page as the psect `basecode`.
- (784) overfreed** **(Assembler)**  
This is an internal compiler error. Contact Microchip Technical Support with details.
- (785) too many temporary labels** **(Assembler)**  
There are too many temporary labels in this assembler file. The assembler allows a maximum of 2000 temporary labels.
- (787) can't handle "v\_rtype" of \* in copyexpr** **(Assembler)**  
This is an internal compiler error. Contact Microchip Technical Support with details.

# MPLAB® XC8 C Compiler User's Guide

---

- (788) invalid character "\*" in number** **(Assembler)**  
A number contained a character that was not part of the range 0-9 or 0-F.
- (790) end of file inside conditional** **(Assembler)**  
END-of-FILE was encountered while scanning for an "endif" to match a previous "if".
- (793) unterminated macro argument** **(Assembler)**  
An argument to a macro is not terminated. Note that angle brackets (" $<$ " " $>$ ") are used to quote macro arguments.
- (794) invalid number syntax** **(Assembler)**  
The syntax of a number is invalid. This, for example, can be use of 8 or 9 in an octal number, or other malformed numbers.
- (796) use of LOCAL outside macros is illegal** **(Assembler)**  
The `LOCAL` directive is only legal inside macros. It defines local labels that will be unique for each invocation of the macro.
- (797) syntax error in LOCAL argument** **(Assembler)**  
A symbol defined using the `LOCAL` assembler directive in an assembler macro is syntactically incorrect. Ensure that all symbols and all other assembler identifiers conform with the assembly language of the target device.
- (798) use of macro arguments in a LOCAL directive is illegal** **(Assembler)**  
The list of labels after the directive `LOCAL` cannot include any of the formal parameters to an enclosing macro, for example:
- ```
mmm MACRO a1
    MOVE    r0, #a1
    LOCAL  a1 ; oops -- the parameter cannot be used with LOCAL
ENDM
```
- (799) REPT argument must be  $\geq 0$**  **(Assembler)**  
The argument to a `REPT` directive must be greater than zero, for example:
- ```
REPT -2          ; -2 copies of this code? */
    MOVE    r0, [r1]++
ENDM
```
- (800) undefined symbol "\*" **(Assembler)****  
The named symbol is not defined in this module, and has not been specified `GLOBAL`.
- (801) range check too complex** **(Assembler)**  
This is an internal compiler error. Contact Microchip Technical Support with details.
- (802) invalid address after END directive** **(Assembler)**  
The start address of the program which is specified after the assembler `END` directive must be a label in the current file.

# Error and Warning Messages

---

- (803) undefined temporary label** **(Assembler)**  
A temporary label has been referenced that is not defined. Note that a temporary label must have a number  $\geq 0$ .
- (804) write error on object file** **(Assembler)**  
The assembler failed to write to an object file. This can be an internal compiler error. Contact Microchip Technical Support with details.
- (806) attempted to get an undefined object (\*)** **(Assembler)**  
This is an internal compiler error. Contact Microchip Technical Support with details.
- (807) attempted to set an undefined object (\*)** **(Assembler)**  
This is an internal compiler error. Contact Microchip Technical Support with details.
- (808) bad size in add\_reloc()** **(Assembler)**  
This is an internal compiler error. Contact Microchip Technical Support with details.
- (809) unknown addressing mode (\*)** **(Assembler)**  
An unknown addressing mode was used in the assembly file.
- (811) "cnt" too large (\*) in display()** **(Assembler)**  
This is an internal compiler error. Contact Microchip Technical Support with details.
- (814) device type not defined** **(Assembler)**  
The device must be defined either from the command line (e.g., -16c84), via the device assembler directive, or via the LIST assembler directive.
- (815) syntax error in chipinfo file at line \*** **(Assembler)**  
The chipinfo file contains non-standard syntax at the specified line.
- (816) duplicate ARCH specification in chipinfo file "" at line \*** **(Assembler, Driver)**  
The chipinfo file has a device section with multiple ARCH values. Only one ARCH value is allowed. If you have not manually edited the chip info file, contact Microchip Technical Support with details.
- (817) unknown architecture in chipinfo file at line \*** **(Assembler, Driver)**  
An chip architecture (family) that is unknown was encountered when reading the chip INI file.
- (818) duplicate BANKS for "" in chipinfo file at line \*** **(Assembler)**  
The chipinfo file has a device section with multiple BANKS values. Only one BANKS value is allowed. If you have not manually edited the chip info file, contact Microchip Technical Support with details.

# MPLAB® XC8 C Compiler User's Guide

---

- (819) duplicate ZEROREG for "" in chipinfo file at line \*** *(Assembler)*
- The chipinfo file has a device section with multiple ZEROREG values. Only one ZEROREG value is allowed. If you have not manually edited the chip info file, contact Microchip Technical Support with details.
- (820) duplicate SPAREBIT for "" in chipinfo file at line \*** *(Assembler)*
- The chipinfo file has a device section with multiple SPAREBIT values. Only one SPAREBIT value is allowed. If you have not manually edited the chip info file, contact Microchip Technical Support with details.
- (821) duplicate INTSAVE for "" in chipinfo file at line \*** *(Assembler)*
- The chipinfo file has a device section with multiple INTSAVE values. Only one INTSAVE value is allowed. If you have not manually edited the chip info file, contact Microchip Technical Support with details.
- (822) duplicate ROMSIZE for "" in chipinfo file at line \*** *(Assembler)*
- The chipinfo file has a device section with multiple ROMSIZE values. Only one ROMSIZE value is allowed. If you have not manually edited the chip info file, contact Microchip Technical Support with details.
- (823) duplicate START for "" in chipinfo file at line \*** *(Assembler)*
- The chipinfo file has a device section with multiple START values. Only one START value is allowed. If you have not manually edited the chip info file, contact Microchip Technical Support with details.
- (824) duplicate LIB for "" in chipinfo file at line \*** *(Assembler)*
- The chipinfo file has a device section with multiple LIB values. Only one LIB value is allowed. If you have not manually edited the chip info file, contact Microchip Technical Support with details.
- (825) too many RAMBANK lines in chipinfo file for ""** *(Assembler)*
- The chipinfo file contains a device section with too many RAMBANK fields. Reduce the number of values.
- (826) inverted ram bank in chipinfo file at line \*** *(Assembler, Driver)*
- The second HEX number specified in the RAM field in the chipinfo file must be greater in value than the first.
- (827) too many COMMON lines in chipinfo file for ""** *(Assembler)*
- There are too many lines specifying common (access bank) memory in the chip configuration file.
- (828) inverted common bank in chipinfo file at line \*** *(Assembler, Driver)*
- The second HEX number specified in the COMMON field in the chipinfo file must be greater in value than the first. Contact Microchip Technical Support if you have not modified the chipinfo INI file.

# Error and Warning Messages

---

**(829) unrecognized line in chipinfo file at line \*** **(Assembler)**

The chipinfo file contains a device section with an unrecognized line. Contact Microchip Technical Support if the INI has not been edited.

**(830) missing ARCH specification for "" in chipinfo file** **(Assembler)**

The chipinfo file has a device section without an ARCH values. The architecture of the device must be specified. Contact Microchip Technical Support if the chipinfo file has not been modified.

**(832) empty chip info file ""** **(Assembler)**

The chipinfo file contains no data. If you have not manually edited the chip info file, contact Microchip Technical Support with details.

**(833) no valid entries in chipinfo file** **(Assembler)**

The chipinfo file contains no valid device descriptions.

**(834) page width must be >= 60** **(Assembler)**

The listing page width must be at least 60 characters. Any less will not allow a properly formatted listing to be produced, for example:

```
LIST C=10 ; the page width will need to be wider than this
```

**(835) form length must be >= 15** **(Assembler)**

The form length specified using the `-F length` option must be at least 15 lines. Setting this length to zero is allowed and turns off paging altogether. The default value is zero (pageless).

**(836) no file arguments** **(Assembler)**

The assembler has been invoked without any file arguments. It cannot assemble anything.

**(839) relocation too complex** **(Assembler)**

The complex relocation in this expression is too big to be inserted into the object file.

**(840) phase error** **(Assembler)**

The assembler has calculated a different value for a symbol on two different passes. This is commonly due to the redefinition of a psect with conflicting delta values, see [Section 6.2.9.3.4 "Delta"](#).

**(841) bad source/destination for movfp/movpf instruction** **(Assembler)**

The absolute address specified with the `MOVFP/MOVPF` instruction is too large.

**(842) bad bit number** **(Assembler)**

A bit number must be an absolute expression in the range 0-7.

## (843) a macro name can't also be an EQU/SET symbol (Assembler)

An EQU or SET symbol has been found with the same name as a macro. This is not allowed. For example:

```
getval MACRO
    MOV  r0, r1
ENDM
getval EQU 55h ; oops -- choose a different name to the macro
```

## (844) lexical error (Assembler)

An unrecognized character or token has been seen in the input.

## (845) symbol "" defined more than once (Assembler)

This symbol has been defined in more than one place. The assembler will issue this error if a symbol is defined more than once in the same module, for example:

```
_next:
    MOVE  r0, #55
    MOVE  [r1], r0
_next: ; oops -- choose a different name
```

The linker will issue this warning if the symbol (C or assembler) was defined multiple times in different modules. The names of the modules are given in the error message. Note that C identifiers often have an *underscore* prepended to their name after compilation.

## (846) relocation error (Assembler)

It is not possible to add together two relocatable quantities. A constant can be added to a relocatable value, and two relocatable addresses in the same psect can be subtracted. An absolute value must be used in various places where the assembler must know a value at assembly time.

## (847) operand error (Assembler)

The operand to this opcode is invalid. Check your assembler reference manual for the proper form of operands for this instruction.

## (848) label defined in this module has also been declared EXTRN (Assembler)

The definition for an assembly label, and an EXTRN declaration for the same symbol, appear in the same module. Use GLOBAL instead of EXTRN if you want this symbol to be accessible from other modules.

## (849) illegal instruction for this device (Assembler)

The instruction is not supported by this device.

## (850) PAGESEL not usable with this device (Assembler)

The PAGESEL pseudo-instruction is not usable with the device selected.

## (851) illegal destination (Assembler)

The destination (either , f or , w ) is not correct for this instruction.

# Error and Warning Messages

---

**(852) radix must be from 2 - 16** **(Assembler)**

The radix specified using the `RADIX` assembler directive must be in the range from 2 (binary) to 16 (hexadecimal).

**(853) invalid size for FNSIZE directive** **(Assembler)**

The assembler `FNSIZE` assembler directive arguments must be positive constants.

**(855) ORG argument must be a positive constant** **(Assembler)**

An argument to the `ORG` assembler directive must be a positive constant or a symbol which has been equated to a positive constant, for example:

```
ORG -10 /* this must a positive offset to the current psect */
```

**(856) ALIGN argument must be a positive constant** **(Assembler)**

The `align` assembler directive requires a non-zero positive integer argument.

**(857) use of both local and global psect flags is illegal with same psect** **(Linker)**

A local psect cannot have the same name as a global psect, for example:

```
psect text,class=CODE          ; the text psect is implicitly global
    MOVE    r0, r1
; elsewhere:
psect text,local,class=CODE
    MOVE    r2, r4
```

The `global` flag is the default for a psect if its scope is not explicitly stated.

**(859) argument to C option must specify a positive constant** **(Assembler)**

The parameter to the `LIST` assembler control's `C=` option (which sets the column width of the listing output) must be a positive decimal constant number, for example:

```
LIST C=a0h ; constant must be decimal and positive,
           try: LIST C=80
```

**(860) page width must be >= 49** **(Assembler)**

The page width suboption to the `LIST` assembler directive must specify a width of at least 49.

**(861) argument to N option must specify a positive constant** **(Assembler)**

The parameter to the `LIST` assembler control's `N` option (which sets the page length for the listing output) must be a positive constant number, for example:

```
LIST N=-3 ; page length must be positive
```

**(862) symbol is not external** **(Assembler)**

A symbol has been declared as `EXTRN` but is also defined in the current module.

**(863) symbol can't be both extern and public** **(Assembler)**

If the symbol is declared as `extern`, it is to be imported. If it is declared as `public`, it is to be exported from the current module. It is not possible for a symbol to be both.

## (864) argument to "size" psect flag must specify a positive constant (Assembler)

The parameter to the PSECT assembler directive's `size` option must be a positive constant number, for example:

```
PSECT text,class=CODE,size=-200 ; a negative size?
```

## (865) psect flag "size" redefined (Assembler)

The `size` flag to the PSECT assembler directive is different from a previous PSECT directive, for example:

```
psect spdata,class=RAM,size=400
; elsewhere:
psect spdata,class=RAM,size=500
```

## (866) argument to "reloc" psect flag must specify a positive constant (Assembler)

The parameter to the PSECT assembler directive's `reloc` option must be a positive constant number, for example:

```
psect test,class=CODE,reloc=-4 ; the reloc must be positive
```

## (867) psect flag "reloc" redefined (Assembler)

The `reloc` flag to the PSECT assembler directive is different from a previous PSECT directive, for example:

```
psect spdata,class=RAM,reloc=4
; elsewhere:
psect spdata,class=RAM,reloc=8
```

## (868) argument to "delta" psect flag must specify a positive constant (Assembler)

The parameter to the PSECT assembler directive's `DELTA` option must be a positive constant number, for example:

```
PSECT text,class=CODE,delta=-2 ; negative delta value doesn't make sense
```

## (869) psect flag "delta" redefined (Assembler)

The 'DELTA' option of a psect has been redefined more than once in the same module.

## (870) argument to "pad" psect flag must specify a positive constant (Assembler)

The parameter to the PSECT assembler directive's 'PAD' option must be a non-zero positive integer.

## (871) argument to "space" psect flag must specify a positive constant (Assembler)

The parameter to the PSECT assembler directive's `space` option must be a positive constant number, for example:

```
PSECT text,class=CODE,space=-1 ; space values start at zero
```

## (872) psect flag "space" redefined (Assembler)

The `space` flag to the PSECT assembler directive is different from a previous PSECT directive, for example:

```
psect spdata,class=RAM,space=0
; elsewhere:
psect spdata,class=RAM,space=1
```



# Error and Warning Messages

---

## **(873) a psect can only be in one class**

**(Assembler)**

You cannot assign a psect to more than one class. The psect was defined differently at this point than when it was defined elsewhere. A psect's class is specified via a flag as in the following:

```
psect text,class=CODE
```

Look for other psect definitions that specify a different class name.

## **(874) a psect can only have one "with" option**

**(Assembler)**

A psect can only be placed with one other psect. Look for other psect definitions that specify a different `with` psect name. A psect's `with` option is specified via a flag, as shown in the following:

```
psect bss,with=data  
; elsewhere  
psect bss,with=lktab ; oops -- bss is to be linked with two psects
```

## **(875) bad character constant in expression**

**(Assembler)**

The character constant was expected to consist of only one character, but was found to be greater than one character or none at all. An assembler specific example:

```
MOV r0, #'12' ; '12' specifies two characters
```

## **(876) syntax error**

**(Assembler)**

A syntax error has been detected. This could be caused a number of things.

## **(877) yacc stack overflow**

**(Assembler)**

This is an internal compiler error. Contact Microchip Technical Support with details.

## **(878) -S option used: "" ignored**

**(Driver)**

The indicated assembly file has been supplied to the driver in conjunction with the `-S` option. The driver really has nothing to do because the file is already an assembly file.

## **(880) invalid number of parameters. Use "\*" -HELP" for help**

**(Driver)**

Improper command-line usage of the of the compiler's driver.

## **(881) setup succeeded**

**(Driver)**

The compiler has been successfully setup using the `--setup` driver option.

## **(883) setup failed**

**(Driver)**

The compiler was not successfully setup using the `--setup` driver option. Ensure that the directory argument to this option is spelled correctly, is syntactically correct for your host operating system and it exists.

- (884) please ensure you have write permissions to the configuration file** *(Driver)*
- The compiler was not successfully setup using the `--setup` driver option because the driver was unable to access the XML configuration file. Ensure that you have write permission to this file. The driver will search the following configuration files in order:
- the file specified by the environment variable `XC_XML`
  - the file `/etc/xc.xml` if the directory `/etc` is writable and there is no `.xc.xml` file in your home directory
  - the file `.xc.xml` file in your home directory
- If none of the files can be located, then the above error will occur.
- (889) this \* compiler has expired** *(Driver)*
- The demo period for this compiler has concluded.
- (890) contact Microchip to purchase and re-activate this compiler** *(Driver)*
- The evaluation period of this demo installation of the compiler has expired. You will need to purchase the compiler to re-activate it. If, however, you sincerely believe the evaluation period has ended prematurely, contact Microchip technical support.
- (891) can't open psect usage map file "": \*** *(Driver)*
- The driver was unable to open the indicated file. The psect usage map file is generated by the driver when the driver option `--summary=file` is used. Ensure that the file is not open in another application.
- (892) can't open memory usage map file "": \*** *(Driver)*
- The driver was unable to open the indicated file. The memory usage map file is generated by the driver when the driver option `--summary=file` is used. Ensure that the file is not open in another application.
- (893) can't open HEX usage map file "": \*** *(Driver)*
- The driver was unable to open the indicated file. The HEX usage map file is generated by the driver when the driver option `--summary=file` is used. Ensure that the file is not open in another application.
- (894) unknown source file type ""** *(Driver)*
- The extension of the indicated input file could not be determined. Only files with the extensions `as`, `c`, `obj`, `usb`, `pl`, `lib` or `HEX` are identified by the driver.
- (895) can't request and specify options in the one command** *(Driver)*
- The usage of the driver options `--getoption` and `--setoption` is mutually exclusive.
- (896) no memory ranges specified for data space** *(Driver)*
- No on-chip or external memory ranges have been specified for the data space memory for the device specified.
- (897) no memory ranges specified for program space** *(Driver)*
- No on-chip or external memory ranges have been specified for the program space memory for the device specified.

# Error and Warning Messages

---

**(899) can't open option file "" for application "": \*** **(Driver)**

An option file specified by a `--getoption` or `--setoption` driver option could not be opened. If you are using the `--setoption` option, ensure that the name of the file is spelled correctly and that it exists. If you are using the `--getoption` option ensure that this file can be created at the given location or that it is not in use by any other application.

**(900) exec failed: \*** **(Driver)**

The subcomponent listed failed to execute. Does the file exist? Try re-installing the compiler.

**(902) no chip name specified; use "-CHIPINFO" to see available chip names** **(Driver)**

The driver was invoked without selecting what chip to build for. Running the driver with the `-CHIPINFO` option will display a list of all chips that could be selected to build for.

**(904) illegal format specified in "" option** **(Driver)**

The usage of this option was incorrect. Confirm correct usage with `-HELP` or refer to the part of the manual that discusses this option.

**(905) illegal application specified in "" option** **(Driver)**

The application given to this option is not understood or does not belong to the compiler.

**(907) unknown memory space tag "" in "" option specification** **(Driver)**

A parameter to this memory option was a string but did not match any valid *tags*. Refer to the section of this manual that describes this option to see what tags (if any) are valid for this device.

**(908) exit status = \*** **(Driver)**

One of the subcomponents being executed encountered a problem and returned an error code. Other messages should have been reported by the subcomponent to explain the problem that was encountered.

**(913) "" option can cause compiler errors in some standard header files** **(Driver)**

Using this option will invalidate some of the qualifiers used in the standard header files, resulting in errors. This issue and its solution are detailed in the section of this manual that specifically discusses this option.

**(915) no room for arguments** **(Preprocessor, Parser, Code Generator, Linker, Objtohex)**

The code generator could not allocate any more memory.

**(917) argument too long** **(Preprocessor, Parser)**

This is an internal compiler error. Contact Microchip Technical Support with details.

**(918) \*: no match** **(Preprocessor, Parser)**

This is an internal compiler error. Contact Microchip Technical Support with details.

- (919) \* in chipinfo file "\*" at line \*** **(Driver)**  
The specified parameter in the chip configuration file is illegal.
- (920) empty chipinfo file** **(Driver, Assembler)**  
The chip configuration file was able to be opened but it was empty. Try re-installing the compiler.
- (922) chip "\*" not present in chipinfo file "\*"**  **(Driver)**  
The chip selected does not appear in the compiler's chip configuration file. Contact Microchip to see whether support for this device is available or it is necessary to upgrade the version of your compiler.
- (923) unknown suboption "\*"**  **(Driver)**  
This option can take suboptions, but this suboption is not understood. This can just be a simple spelling error. If not, `-HELP` to look up what suboptions are permitted here.
- (924) missing argument to "\*" option** **(Driver)**  
This option expects more data but none was given. Check the usage of this option.
- (925) extraneous argument to "\*" option** **(Driver)**  
This option does not accept additional data, yet additional data was given. Check the usage of this option.
- (926) duplicate "\*" option** **(Driver)**  
This option can only appear once, but appeared more than once.
- (928) bad "\*" option value** **(Driver, Assembler)**  
The indicated option was expecting a valid hexadecimal integer argument.
- (929) bad "\*" option ranges** **(Driver)**  
This option was expecting a parameter in a range format (*start\_of\_range-end\_of\_range*), but the parameter did not conform to this syntax.
- (930) bad "\*" option specification** **(Driver)**  
The parameters to this option were not specified correctly. Run the driver with `-HELP` or refer to the driver's chapter in this manual to verify the correct usage of this option.
- (931) command file not specified** **(Driver)**  
Command file to this application, expected to be found after `'@'` or `'<'` on the command line was not found.
- (939) no file arguments** **(Driver)**  
The driver has been invoked with no input files listed on its command line. If you are getting this message while building through a third party IDE, perhaps the IDE could not verify the source files to compile or object files to link and withheld them from the command line.

# Error and Warning Messages

---

- (940) \*-bit \* placed at \*** **(Objtohex)**  
Presenting the result of the requested calculation.
- (941) bad "" assignment; USAGE: \*\*** **(Hexmate)**  
An option to HEXMATE was incorrectly used or incomplete. Follow the usage supplied by the message and ensure that the option has been formed correctly and completely.
- (942) unexpected character on line \* of file ""** **(Hexmate)**  
File contains a character that was not valid for this type of file, the file can be corrupt. For example, an Intel HEX file is expected to contain only ASCII representations of hexadecimal digits, colons (:) and line formatting. The presence of any other characters will result in this error.
- (944) data conflict at address \*h between \* and \*** **(Hexmate)**  
Sources to Hexmate request differing data to be stored to the same address. To force one data source to override the other, use the '+' specifier. If the two named sources of conflict are the same source, then the source can contain an error.
- (945) range (\*h to \*h) contained an indeterminate value** **(Hexmate)**  
The range for this calculation contained a value that could not be resolved. This can happen if the result was to be stored within the address range of the calculation.
- (948) result width must be between 1 and 4 bytes** **(Hexmate)**  
The requested byte size is illegal. Checksum results must be within 1 to 4 bytes wide. Check the parameters to the -CKSUM option.
- (949) start of range must be less than end of range** **(Hexmate)**  
The -CKSUM option has been given a range where the start is greater than the end. The parameters can be incomplete or entered in the wrong order.
- (951) start of fill range must be less than end of range** **(Hexmate)**  
The -FILL option has been given a range where the start is greater than the end. The parameters can be incomplete or entered in the wrong order.
- (953) unknown -HELP sub-option: \*** **(Hexmate)**  
Invalid sub-option passed to -HELP. Check the spelling of the sub-option or use -HELP with no sub-option to list all options.
- (956) -SERIAL value must be between 1 and \* bytes long** **(Hexmate)**  
The serial number being stored was out of range. Ensure that the serial number can be stored in the number of bytes permissible by this option.
- (958) too many input files specified; \* file maximum** **(Hexmate)**  
Too many file arguments have been used. Try merging these files in several stages rather than in one command.

# MPLAB® XC8 C Compiler User's Guide

---

- (960) unexpected record type (\*) on line \* of ""** *(Hexmate)*  
Intel HEX file contained an invalid record type. Consult the Intel HEX format specification for valid record types.
- (962) forced data conflict at address \*h between \* and \*** *(Hexmate)*  
Sources to `HEXMATE` force differing data to be stored to the same address. More than one source using the '+' specifier store data at the same address. The actual data stored there cannot be what you expect.
- (963) range includes voids or unspecified memory locations** *(Hexmate)*  
The hash (checksum) range had gaps in data content. The runtime hash calculated is likely to differ from the compile-time hash due to gaps/unused bytes within the address range that the hash is calculated over. Filling unused locations with a known value will correct this.
- (964) unpaired nibble in -FILL value will be truncated** *(Hexmate)*  
The hexadecimal code given to the `FILL` option contained an incomplete byte. The incomplete byte (nibble) will be disregarded.
- (965) -STRPACK option not yet implemented; option will be ignored** *(Hexmate)*  
This option currently is not available and will be ignored.
- (966) no END record for HEX file ""** *(Hexmate)*  
Intel HEX file did not contain a record of type `END`. The HEX file can be incomplete.
- (967) unused function definition "" (from line \*)** *(Parser)*  
The indicated `static` function was never called in the module being compiled. Being `static`, the function cannot be called from other modules so this warning implies the function is never used. Either the function is redundant, or the code that was meant to call it was excluded from compilation or misspelled the name of the function.
- (968) unterminated string** *(Assembler)*  
A string constant appears not to have a closing quote.
- (969) end of string in format specifier** *(Parser)*  
The format specifier for the `printf()` style function is malformed.
- (970) character not valid at this point in format specifier** *(Parser)*  
The `printf()` style format specifier has an illegal character.
- (971) type modifiers not valid with this format** *(Parser)*  
Type modifiers cannot be used with this format.
- (972) only modifiers "h" and "l" valid with this format** *(Parser)*  
Only modifiers `h` (`short`) and `l` (`long`) are legal with this `printf` format specifier.
- (973) only modifier "l" valid with this format** *(Parser)*  
The only modifier that is legal with this format is `l` (for `long`).

# Error and Warning Messages

---

**(974) type modifier already specified** **(Parser)**

This type modifier has already be specified in this type.

**(975) invalid format specifier or type modifier** **(Parser)**

The format specifier or modifier in the `printf`-style string is illegal for this particular format.

**(976) field width not valid at this point** **(Parser)**

A field width cannot appear at this point in a `printf()` type format specifier.

**(978) this identifier is already an enum tag** **(Parser)**

This identifier following a `struct` or `union` keyword is already the tag for an enumerated type, and thus should only follow the keyword `enum`, for example:

```
enum IN {ONE=1, TWO};
struct IN {           /* oops -- IN is already defined */
    int a, b;
};
```

**(979) this identifier is already a struct tag** **(Parser)**

This identifier following a `union` or `enum` keyword is already the tag for a structure, and thus should only follow the keyword `struct`, for example:

```
struct IN {
    int a, b;
};
enum IN {ONE=1, TWO}; /* oops -- IN is already defined */
```

**(980) this identifier is already a union tag** **(Parser)**

This identifier following a `struct` or `enum` keyword is already the tag for a union, and thus should only follow the keyword `union`, for example:

```
union IN {
    int a, b;
};
enum IN {ONE=1, TWO}; /* oops -- IN is already defined */
```

**(981) pointer required** **(Parser)**

A pointer is required here, for example:

```
struct DATA data;
data->a = 9;           /* data is a structure,
                       not a pointer to a structure */
```

**(982) unknown op "\*" in nextuse()** **(Assembler)**

This is an internal compiler error. Contact Microchip Technical Support with details.

**(983) storage class redeclared** **(Parser)**

A variable previously declared as being *static* , has now be redeclared as *extern*.

**(984) type redeclared** **(Parser)**

The type of this function or object has been redeclared. This can occur because of two incompatible declarations, or because an implicit declaration is followed by an incompatible declaration, for example:

```
int a;
char a; /* oops -- what is the correct type? */
```

**(985) qualifiers redeclared** **(Parser)**

This function or variable has different qualifiers in different declarations.

**(986) enum member redeclared** **(Parser)**

A member of an enumeration is defined twice or more with differing values. Does the member appear twice in the same list or does the name of the member appear in more than one enum list?

**(987) arguments redeclared** **(Parser)**

The data types of the parameters passed to this function do not match its prototype.

**(988) number of arguments redeclared** **(Parser)**

The number of arguments in this function declaration does not agree with a previous declaration of the same function.

**(989) module has code below file base of \*h** **(Linker)**

This module has code below the address given, but the `-C` option has been used to specify that a binary output file is to be created that is mapped to this address. This would mean code from this module would have to be placed before the beginning of the file! Check for missing `psect` directives in assembler files.

**(990) modulus by zero in #if; zero result assumed** **(Preprocessor)**

A modulus operation in a `#if` expression has a zero divisor. The result has been assumed to be zero, for example:

```
#define ZERO 0
#if FOO%ZERO /* this will have an assumed result of 0 */
    #define INTERESTING
#endif
```

**(991) integer expression required** **(Parser)**

In an `enum` declaration, values can be assigned to the members, but the expression must evaluate to a constant of type `int`, for example:

```
enum {one = 1, two, about_three = 3.12};
/* no non-int values allowed */
```

**(992) can't find op** **(Assembler)**

This is an internal compiler error. Contact Microchip Technical Support with details.

**(993) some command-line options are disabled** **(Driver)**

The compiler is operating in demo mode. Some command-line options are disabled.



# Error and Warning Messages

---

**(994) some command-line options are disabled and compilation is delayed** *(Driver)*

The compiler is operating in demo mode. Some command-line options are disabled, the compilation speed will be slower.

**(995) some command-line options are disabled; code size is limited to 16kB, compilation is delayed** *(Driver)*

The compiler is operating in demo mode. Some command-line options are disabled; the compilation speed will be slower, and the maximum allowed code size is limited to 16 KB.

# MPLAB® XC8 C Compiler User's Guide

---

## MESSAGES 1000-1249

**(1015) missing "" specification in chipinfo file "" at line \*** *(Driver)*

This attribute was expected to appear at least once but was not defined for this chip.

**(1016) missing argument\* to "" specification in chipinfo file "" at line \*** *(Driver)*

This value of this attribute is blank in the chip configuration file.

**(1017) extraneous argument\* to "" specification in chipinfo file "" at line \*** *(Driver)*

There are too many attributes for the listed specification in the chip configuration file.

**(1018) illegal number of "" specification\* (\* found; \* expected) in chipinfo file "" at line \*** *(Driver)*

This attribute was expected to appear a certain number of times; but, it did not appear for this chip.

**(1019) duplicate "" specification in chipinfo file "" at line \*** *(Driver)*

This attribute can only be defined once but has been defined more than once for this chip.

**(1020) unknown attribute "" in chipinfo file "" at line \*** *(Driver)*

The chip configuration file contains an attribute that is not understood by this version of the compiler. Has the chip configuration file or the driver been replaced with an equivalent component from another version of this compiler?

**(1021) syntax error reading "" value in chipinfo file "" at line \*** *(Driver)*

The chip configuration file incorrectly defines the specified value for this device. If you are modifying this file yourself, take care and refer to the comments at the beginning of this file for a description on what type of values are expected here.

**(1022) syntax error reading "" range in chipinfo file "" at line \*** *(Driver)*

The chip configuration file incorrectly defines the specified range for this device. If you are modifying this file yourself, take care and refer to the comments at the beginning of this file for a description on what type of values are expected here.

**(1024) syntax error in chipinfo file "" at line \*** *(Driver)*

The chip configuration file contains a syntax error at the line specified.

**(1025) unknown architecture in chipinfo file "" at line \*** *(Driver)*

The attribute at the line indicated defines an architecture that is unknown to this compiler.

**(1026) missing architecture in chipinfo file "" at line \*** *(Assembler)*

The chipinfo file has a device section without an ARCH values. The architecture of the device must be specified. Contact Microchip Technical Support if the chipinfo file has not been modified.

# Error and Warning Messages

---

- (1027) activation was successful** *(Driver)*  
The compiler was successfully activated.
- (1028) activation was not successful - error code (\*)** *(Driver)*  
The compiler did not activated successfully.
- (1029) compiler not installed correctly - error code (\*)** *(Driver)*  
This compiler has failed to find any activation information and cannot proceed to execute. The compiler can have been installed incorrectly or incompletely. The error code quoted can help diagnose the reason for this failure. You can be asked for this failure code if contacting Microchip for assistance with this problem.
- (1030) Hexmate - Intel HEX editing utility (Build 1.%i)** *(Hexmate)*  
Indicating the version number of the `HEXMATE` being executed.
- (1031) USAGE: \* [input1.HEX] [input2.HEX]... [inputN.HEX] [options]** *(Hexmate)*  
The suggested usage of `HEXMATE`.
- (1032) use `-HELP=<option>` for usage of these command line options** *(Hexmate)*  
More detailed information is available for a specific option by passing that option to the `HELP` option.
- (1033) available command-line options:** *(Hexmate)*  
This is a simple heading that appears before the list of available options for this application.
- (1034) type `""` for available options** *(Hexmate)*  
It looks like you need help. This advisory suggests how to get more information about the options available to this application or the usage of these options.
- (1035) bad argument count (\*)** *(Parser)*  
The number of arguments to a function is unreasonable. This is an internal compiler error. Contact Microchip Technical Support with details.
- (1036) bad `""` optional header length (0x\* expected)** *(Cromwell)*  
The length of the optional header in this COFF file was of an incorrect length.
- (1037) short read on \*** *(Cromwell)*  
When reading the type of data indicated in this message, it terminated before reaching its specified length.
- (1038) string table length too short** *(Cromwell)*  
The specified length of the COFF string table is less than the minimum.
- (1039) inconsistent symbol count** *(Cromwell)*  
The number of symbols in the symbol table has exceeded the number indicated in the COFF header.

# MPLAB® XC8 C Compiler User's Guide

---

- (1040) bad : record 0x\*, 0x\*** **(Cromwell)**  
A record of the type specified failed to match its own value.
- (1041) short record** **(Cromwell)**  
While reading a file, one of the file's records ended short of its specified length.
- (1042) unknown \* record type 0x\*** **(Cromwell)**  
The type indicator of this record did not match any valid types for this file format.
- (1043) unknown optional header** **(Cromwell)**  
When reading this Microchip COFF file, the optional header within the file header was of an incorrect length.
- (1044) end of file encountered** **(Cromwell, Linker)**  
The end of the file was found while more data was expected. Has this input file been truncated?
- (1045) short read on block of \* bytes** **(Cromwell)**  
A while reading a block of byte data from a UBROF record, the block ended before the expected length.
- (1046) short string read** **(Cromwell)**  
A while reading a string from a UBROF record, the string ended before the specified length.
- (1047) bad type byte for UBROF file** **(Cromwell)**  
This UBROF file did not begin with the correct record.
- (1048) bad time/date stamp** **(Cromwell)**  
This UBROF file has a bad time/date stamp.
- (1049) wrong CRC on 0x\* bytes; should be \*** **(Cromwell)**  
An end record has a mismatching CRC value in this UBROF file.
- (1050) bad date in 0x52 record** **(Cromwell)**  
A debug record has a bad date component in this UBROF file.
- (1051) bad date in 0x01 record** **(Cromwell)**  
A start of program record or segment record has a bad date component in this UBROF file.
- (1052) unknown record type** **(Cromwell)**  
A record type could not be determined when reading this UBROF file.
- (1053) additional RAM ranges larger than bank size** **(Driver)**  
A block of additional RAM being requested exceeds the size of a bank. Try breaking the block into multiple ranges that do not cross bank boundaries.

# Error and Warning Messages

---

- (1054) additional RAM range out of bounds** **(Driver)**  
The RAM memory range as defined through custom RAM configuration is out of range.
- (1055) RAM range out of bounds (\*)** **(Driver)**  
The RAM memory range as defined in the chip configuration file or through custom configuration is out of range.
- (1056) unknown chip architecture** **(Driver)**  
The compiler is attempting to compile for a device of an architecture that is either unsupported or disabled.
- (1057) fast double option only available on 17 series processors** **(Driver)**  
The fast double library cannot be selected for this device. These routines are only available for PIC17 devices.
- (1058) assertion** **(Code Generator)**  
This is an internal compiler error. Contact Microchip Technical Support with details.
- (1059) rewrite loop** **(Code Generator)**  
This is an internal compiler error. Contact Microchip Technical Support with details.
- (1081) static initialization of persistent variable ""** **(Parser, Code Generator)**  
A persistent variable has been assigned an initial value. This is somewhat contradictory as the initial value will be assigned to the variable during execution of the compiler's startup code; however, the *persistent* qualifier requests that this variable shall be unchanged by the compiler's startup code.
- (1082) size of initialized array element is zero** **(Code Generator)**  
This is an internal compiler error. Contact Microchip Technical Support with details.
- (1088) function pointer "" is used but never assigned a value** **(Code Generator)**  
A function call involving a function pointer was made, but the pointer was never assigned a target address, for example:  

```
void (*fp)(int);  
fp(23);      /*oops -- what function does fp point to? */
```
- (1089) recursive function call to ""** **(Code Generator)**  
A recursive call to the specified function has been found. The call can be direct or indirect (using function pointers) and can be either a function calling itself, or calling another function whose call graph includes the function under consideration.
- (1090) variable "" is not used** **(Code Generator)**  
This variable is declared but has not been used by the program. Consider removing it from the program.
- (1091) main function "" not defined** **(Code Generator)**  
The *main* function has not been defined. Every C program must have a function called *main*.

# MPLAB® XC8 C Compiler User's Guide

---

- (1094) bad derived type** **(Code Generator)**  
This is an internal compiler error. Contact Microchip Technical Support with details.
- (1095) bad call to typeSub()** **(Code Generator)**  
This is an internal compiler error. Contact Microchip Technical Support with details.
- (1096) type should be unqualified** **(Code Generator)**  
This is an internal compiler error. Contact Microchip Technical Support with details.
- (1097) unknown type string ""** **(Code Generator)**  
This is an internal compiler error. Contact Microchip Technical Support with details.
- (1098) conflicting declarations for variable "" (\*:\*)** **(Parser, Code Generator)**  
Differing type information has been detected in the declarations for a variable, or between a declaration and the definition of a variable, for example:  

```
extern long int test;
int test; /* oops -- which is right? int or long int ? */
```
- (1104) unqualified error** **(Code Generator)**  
This is an internal compiler error. Contact Microchip Technical Support with details.
- (1118) bad string "" in getexpr(J)** **(Code Generator)**  
This is an internal compiler error. Contact Microchip Technical Support with details.
- (1119) bad string "" in getexpr(LRN)** **(Code Generator)**  
This is an internal compiler error. Contact Microchip Technical Support with details.
- (1121) expression error** **(Code Generator)**  
This is an internal compiler error. Contact Microchip Technical Support with details.
- (1137) match() error: \*** **(Code Generator)**  
This is an internal compiler error. Contact Microchip Technical Support with details.
- (1157) W register must be W9** **(Assembler)**  
The working register required here has to be W9, but an other working register was selected.
- (1159) W register must be W11** **(Assembler)**  
The working register required here has to be W11, but an other working register was selected.
- (1178) the "" option has been removed and has no effect** **(Driver)**  
This option no longer exists in this version of the compiler and has been ignored. Use the compiler's `-help` option or refer to the manual to find a replacement option.

# Error and Warning Messages

---

**(1179) interrupt level for function "\*" cannot exceed \*** **(Code Generator)**

The interrupt level for the function specified is too high. Each interrupt function is assigned a unique interrupt level. This level is considered when analyzing the call graph and reentrantly called functions. If using the `interrupt_level` pragma, check the value specified.

**(1180) directory "\*" does not exist** **(Driver)**

The directory specified in the setup option does not exist. Create the directory and try again.

**(1182) near variables must be global or static** **(Code Generator)**

A variable qualified as *near* must also be qualified with *static* or made global. An auto variable cannot be qualified as *near*.

**(1183) invalid version number** **(Activation)**

During activation, no matching version number was found on the Microchip activation server database for the serial number specified.

**(1184) activation limit reached** **(Activation)**

The number of activations of the serial number specified has exceeded the maximum number allowed for the license.

**(1185) invalid serial number** **(Activation)**

During activation, no matching serial number was found on the Microchip activation server database.

**(1186) license has expired** **(Driver)**

The time-limited license for this compiler has expired.

**(1187) invalid activation request** **(Driver)**

The compiler has not been correctly activated.

**(1188) network error \*** **(Activation)**

The compiler activation software was unable to connect to the Microchip activation server via the network.

**(1190) FAE license only - not for use in commercial applications** **(Driver)**

Indicates that this compiler has been activated with an FAE license. This license does not permit the product to be used for the development of commercial applications.

**(1191) licensed for educational use only** **(Driver)**

Indicates that this compiler has been activated with an education license. The educational license is only available to educational facilities and does not permit the product to be used for the development of commercial applications.

**(1192) licensed for evaluation purposes only** **(Driver)**

Indicates that this compiler has been activated with an evaluation license.

# MPLAB® XC8 C Compiler User's Guide

---

**(1193) this license will expire on \*** *(Driver)*

The compiler has been installed as a time-limited trial. This trial will end on the date specified.

**(1195) invalid syntax for "\*" option** *(Driver)*

A command line option that accepts additional parameters was given inappropriate data or insufficient data. For example, an option can expect two parameters with both being integers. Passing a string as one of these parameters or supplying only one parameter could result in this error.

**(1198) too many "\*" specifications; \* maximum** *(Hexmate)*

This option has been specified too many times. If possible, try performing these operations over several command lines.

**(1199) compiler has not been activated** *(Driver)*

The trial period for this compiler has expired. The compiler is now inoperable until activated with a valid serial number. Contact Microchip to purchase this software and obtain a serial number.

**(1200) Found %0\*IXh at address \*h** *(Hexmate)*

The code sequence specified in a -FIND option has been found at this address.

**(1201) all FIND/REPLACE code specifications must be of equal width** *(Hexmate)*

All find, replace and mask attributes in this option must be of the same byte width. Check the parameters supplied to this option. For example, finding 1234h (2 bytes) masked with FFh (1 byte) results in an error; but, masking with 00FFh (2 bytes) works.

**(1202) unknown format requested in -FORMAT: \*** *(Hexmate)*

An unknown or unsupported INHX format has been requested. Refer to documentation for supported INHX formats.

**(1203) unpaired nibble in \* value will be truncated** *(Hexmate)*

Data to this option was not entered as whole bytes. Perhaps the data was incomplete or a leading zero was omitted. For example, the value Fh contains only four bits of significant data and is not a whole byte. The value 0Fh contains eight bits of significant data and is a whole byte.

**(1204) \* value must be between 1 and \* bytes long** *(Hexmate)*

An illegal length of data was given to this option. The value provided to this option exceeds the maximum or minimum bounds required by this option.



# Error and Warning Messages

---

**(1205) using the configuration file \*; you can override this with the environment variable  
HTC\_XML (Driver)**

This is the compiler configuration file selected during compiler setup. This can be changed via the HTC\_XML environment variable. This file is used to determine where the compiler has been installed.

**(1207) some of the command line options you are using are now obsolete (Driver)**

Some of the command line options passed to the driver have now been discontinued in this version of the compiler; however, during a grace period these old options will still be processed by the driver.

**(1208) use –help option or refer to the user manual for option details (Driver)**

An obsolete option was detected. Use –help or refer to the manual to find a replacement option that will not result in this advisory message.

**(1209) An old MPLAB tool suite plug-in was detected. (Driver)**

The options passed to the driver resemble those that the Microchip MPLAB 8 IDE would pass to a previous version of this compiler. Some of these options are now obsolete – however, they were still interpreted. It is recommended that you install an updated Microchip options plug-in for the IDE.

**(1210) Visit the Microchip website (www.microchip.com) for a possible upgrade (Driver)**

Visit our website to see if an upgrade is available to address the issue(s) listed in the previous compiler message. Navigate to the MPLAB XC8 C Compiler page and look for a version upgrade downloadable file. If your version is current, contact Microchip Technical Support for further information.

**(1212) Found \* (%0\*IXh) at address \*h (Hexmate)**

The code sequence specified in a -FIND option has been found at this address.

**(1213) duplicate ARCH for \* in chipinfo file at line \* (Assembler, Driver)**

The chipinfo file has a device section with multiple ARCH values. Only one ARCH value is allowed. If you have not manually edited the chip info file, contact Microchip Technical Support with details.

**(1218) can't create cross reference file \* (Assembler)**

The assembler attempted to create a cross reference file; but, it could not be created. Check that the file's path name is correct.

**(1228) unable to locate installation directory (Driver)**

The compiler cannot determine the directory where it has been installed.

**(1230) dereferencing uninitialized pointer "" (Code Generator)**

A pointer that has not yet been assigned a value has been dereferenced. This can result in erroneous behavior at runtime.

**(1235) unknown keyword \* (Driver)**

The token contained in the USB descriptor file was not recognized.

# MPLAB® XC8 C Compiler User's Guide

---

**(1236) invalid argument to \*: \*** **(Driver)**

An option that can take additional parameters was given an invalid parameter value. Check the usage of the option or the syntax or range of the expected parameter.

**(1237) endpoint 0 is pre-defined** **(Driver)**

An attempt has been made to define endpoint 0 in a USB file.

**(1238) FNALIGN failure on \*** **(Linker)**

Two functions have their auto/parameter blocks aligned using the `FNALIGN` directive, but one function calls the other, which implies that must not be aligned. This will occur if a function pointer is assigned the address of each function, but one function calls the other. For example:

```
int one(int a) { return a; }
int two(int a) { return two(a)+2; } /* ! */
int (*ip)(int);
ip = one;
ip(23);
ip = two; /* ip references one and two; two calls one */
ip(67);
```

**(1239) pointer \* has no valid targets** **(Code Generator)**

A function call involving a function pointer was made, but the pointer was never assigned a target address, for example:

```
void (*fp)(int);
fp(23); /* oops -- what function does fp point to? */
```

**(1240) unknown algorithm type (%i)** **(Driver)**

The error file specified after the `-Efile` or `-E+file` options could not be opened. Check to ensure that the file or directory is valid and that has read only access.

**(1241) bad start address in \*** **(Driver)**

The start of range address for the `--CHECKSUM` option could not be read. This value must be a hexadecimal number.

**(1242) bad end address in \*** **(Driver)**

The end of range address for the `--CHECKSUM` option could not be read. This value must be a hexadecimal number.

**(1243) bad destination address in \*** **(Driver)**

The destination address for the `--CHECKSUM` option could not be read. This value must be a hexadecimal number.

**(1245) value greater than zero required for \*** **(Hexmate)**

The `align` operand to the `HEXMATE -FIND` option must be positive.

**(1246) no RAM defined for variable placement** **(Code Generator)**

No memory has been specified to cover the banked RAM memory.

# Error and Warning Messages

---

**(1247) no access RAM defined for variable placement** *(Code Generator)*

No memory has been specified to cover the access bank memory.

**(1248) symbol (\*) encountered with undefined type size** *(Code Generator)*

The code generator was asked to position a variable, but the size of the variable is not known. This is an internal compiler error. Contact Microchip Technical Support with details.

## MESSAGES 1250-1499

### **(1250) could not find space (\* byte\*) for variable \*** *(Code Generator)*

The code generator could not find space in the banked RAM for the variable specified.

### **(1253) could not find space (\* byte\*) for auto/param block** *(Code Generator)*

The code generator could not find space in RAM for the psect that holds `auto` and parameter variables.

### **(1254) could not find space (\* byte\*) for data block** *(Code Generator)*

The code generator could not find space in RAM for the data psect that holds initialized variables.

### **(1255) conflicting paths for output directory** *(Driver)*

The compiler has been given contradictory paths for the output directory via any of the `-O` or `--OUTDIR` options, for example:

```
--outdir=../../   -o../main.HEX
```

### **(1256) undefined symbol "" treated as HEX constant** *(Assembler)*

A token which could either be interpreted as a symbol or a hexadecimal value does not match any previously defined symbol and so will be interpreted as the latter. Use a leading `zero` to avoid the ambiguity, or use an alternate radix specifier such as `0x`. For example:

```
MOV a, F7h ; is this the symbol F7h, or the HEX number 0xF7?
```

### **(1257) local variable "" is used but never given a value** *(Code Generator)*

An `auto` variable has been defined and used in an expression, but it has not been assigned a value in the C code before its first use. Auto variables are not cleared on startup and their initial value is undefined. For example:

```
void main(void) {  
    double src, out;  
    out = sin(src); /* oops -- what value was in src? */  
}
```

### **(1258) possible stack overflow when calling function ""** *(Code Generator)*

The call tree analysis by the code generator indicates that the hardware stack can overflow. This should be treated as a guide only. Interrupts, the assembler optimizer and the program structure can affect the stack usage. The stack usage is based on the C program and does not include any call tree derived from assembly code.

### **(1259) can't optimize for both speed and space** *(Driver)*

The driver has been given contradictory options of compile for speed and compile for space, for example:

```
--opt=speed, space
```

# Error and Warning Messages

---

## **(1260) macro "" redefined** **(Assembler)**

More than one definition for a macro with the same name has been encountered, for example:

```
MACRO fin
    ret
ENDM
MACRO fin ; oops -- was this meant to be a different macro?
    reti
ENDM
```

## **(1261) string constant required** **(Assembler)**

A string argument is required with the DS or DSU directive, for example:

```
DS ONE ; oops -- did you mean DS "ONE"?
```

## **(1262) object "" lies outside available \* space** **(Code Generator)**

An absolute variable was positioned at a memory location which is not within the memory defined for the target device, for example:

```
int data @ 0x800 /* oops -- is this the correct address? */
```

## **(1264) unsafe pointer conversion** **(Code Generator)**

A pointer to one kind of structure has been converted to another kind of structure and the structures do not have a similar definition, for example:

```
struct ONE {
    unsigned a;
    long b; /* ! */
} one;
struct TWO {
    unsigned a;
    unsigned b; /* ! */
} two;
struct ONE * oneptr;
oneptr = & two; /* oops --
                was ONE meant to be same struct as TWO? */
```

## **(1267) fixup overflow referencing \* into \* bytes at 0x\*** **(Linker)**

See error message 1356 for more information.

## **(1268) fixup overflow storing 0x\* in \* bytes at \*** **(Linker)**

See error message 1356 for more information.

## **(1273) Omniscient Code Generation not available in Free mode** **(Driver)**

This message advises that advanced features of the compiler are not be enabled in this Free mode compiler.

## **(1275) the qualifier "" is only applicable to functions** **(Parser)**

A qualifier which only makes sense when used in a function definition has been used with a variable definition.

```
interrupt int dacResult; /* oops --
                        the interrupt qualifier can only be used with functions */
```

# MPLAB® XC8 C Compiler User's Guide

---

- (1276) buffer overflow in DWARF location list** *(Cromwell)*  
A buffer associated with the ELF/DWARF debug file has overflowed. Contact Microchip Technical Support with details.
- (1278) omitting "" which does not have a location** *(Cromwell)*  
A variable has no storage location listed and will be omitted from the debug output. Contact Microchip Technical Support with details.
- (1284) malformed mapfile while generating summary: CLASS expected but not found** *(Driver)*  
The map file being read to produce a memory summary is malformed. Either the file has been edited or corrupted, or this is a compiler error – contact Microchip Technical Support with details.
- (1285) malformed mapfile while generating summary: no name at position \*** *(Driver)*  
The map file being read to produce a memory summary is malformed. Either the file has been edited or corrupted, or this is a compiler error – contact Microchip Technical Support with details.
- (1286) malformed mapfile while generating summary: no link address at position \* (Driver)**  
The map file being read to produce a memory summary is malformed. Either the file has been edited or corrupted, or this is a compiler error – contact Microchip Technical Support with details.
- (1287) malformed mapfile while generating summary: no load address at position \*** *(Driver)*  
The map file being read to produce a memory summary is malformed. Either the file has been edited or corrupted, or this is a compiler error – contact Microchip Technical Support with details.
- (1288) malformed mapfile while generating summary: no length at position \*** *(Driver)*  
The map file being read to produce a memory summary is malformed. Either the file has been edited or corrupted, or this is a compiler error – contact Microchip Technical Support with details.
- (1289) line range limit exceeded, possibly affecting ability to debug code** *(Cromwell)*  
A C statement has produced assembly code output whose length exceeds a preset limit. This means that debug information produced by CROMWELL may not be accurate. This warning does not indicate any potential code failure.
- (1290) buffer overflow in DWARF debugging information entry** *(Cromwell)*  
A buffer associated with the ELF/DWARF debug file has overflowed. Contact Microchip Technical Support with details.
- (1291) bad ELF string table index** *(Cromwell)*  
An ELF file passed to CROMWELL is malformed and cannot be used.
- (1292) malformed define in .SDB file \*** *(Cromwell)*  
The named SDB file passed to CROMWELL is malformed and cannot be used.

# Error and Warning Messages

---

**(1293) couldn't find type for "" in DWARF debugging information entry** (Cromwell)

The type of symbol could not be determined from the SDB file passed to CROMWELL. Either the file has been edited or corrupted, or this is a compiler error – contact Microchip Technical Support with details.

**(1294) there is only one day left until this license expires** (Driver)

The compiler is running as a demo and will be unable to run in PRO mode after the evaluation license has expired in less than one day's time. After expiration, the compiler can be operated in Free mode indefinitely, but will produce a larger output binary.

**(1295) there are \* days left until this license will expire** (Driver)

The compiler is running as a demo and will be unable to run in PRO mode after the evaluation license has expired in the indicated time. After expiration, the compiler can be operated in Free mode indefinitely, but will produce a larger output binary.

**(1296) source file "" conflicts with ""** (Driver)

The compiler has encountered more than one source file with the same base name. This can only be the case if the files are contained in different directories. As the compiler and IDEs based the names of intermediate files on the base names of source files, and intermediate files are always stored in the same location, this situation is illegal. Ensure the base name of all source files are unique.

**(1297) option \* not available in Free mode** (Driver)

Some options are not available when the compiler operates in Free mode. The options disabled are typically related to how the compiler is executed, e.g., --GETOPTION and --SETOPTION, and do not control compiler features related to code generation.

**(1298) use of \* outside macros is illegal** (Assembler)

Some assembler directives, e.g., EXITM, can only be used inside macro definitions.

**(1299) non-standard modifier "" - use "" instead** (Parser)

A printf placeholder modifier has been used which is non-standard. Use the indicated modifier instead. For example, the standard hh modifier should be used in preference to b to indicate that the value should be printed as a char type.

**(1300) maximum number of program classes reached; some classes may be excluded from debugging information** (Cromwell)

CROMWELL is passed a list of class names on the command line. If the number of class names passed in is too large, not all will be used and there is the possibility that debugging information will be inaccurate.

**(1301) invalid ELF section header; skipping** (Cromwell)

CROMWELL found an invalid section in an ELF section header. This section will be skipped.

**(1302) could not find valid ELF output extension for this device** (Cromwell)

The extension could not be for the target device family.

# MPLAB® XC8 C Compiler User's Guide

---

- (1303) invalid variable location detected: \* - \*** *(Cromwell)*  
A symbol location could not be determined from the SDB file.
- (1304) unknown register name: ""** *(Cromwell)*  
The location for the indicated symbol in the SDB file was a register, but the register name was not recognized.
- (1305) inconsistent storage class for variable: ""** *(Cromwell)*  
The storage class for the indicated symbol in the SDB file was not recognized.
- (1306) inconsistent size (\* vs \*) for variable: ""** *(Cromwell)*  
The size of the symbol indicated in the SDB file does not match the size of its type.
- (1307) psect \* truncated to \* bytes** *(Driver)*  
The psect representing either the stack or heap could not be made as large as requested and will be truncated to fit the available memory space.
- (1308) missing/conflicting interrupts sub-option; defaulting to ""** *(Driver)*  
The suboptions to the `--INTERRUPT` option are missing or malformed, for example:  
`--INTERRUPTS=single,multi`  
Oops, did you mean single-vector or multi-vector interrupts?
- (1309) ignoring invalid runtime \* sub-option (\*) using default** *(Driver)*  
The indicated suboption to the `--RUNTIME` option is malformed, for example:  
`--RUNTIME=default,speed:0y1234`  
Oops, that should be `0x1234`.
- (1310) specified speed (\*Hz) exceeds max operating frequency (\*Hz); defaulting to \*Hz** *(Driver)*  
The frequency specified to the `perform` suboption to `--RUNTIME` option is too large for the selected device.  
`--RUNTIME=default,speed:0xffffffff`  
Oops, that value is too large.
- (1311) missing configuration setting for config word \*; using default** *(Driver)*  
The configuration settings for the indicated word have not be supplied in the source code and a default value will be used.
- (1312) conflicting runtime perform sub-option and configuration word settings; assuming \*Hz** *(Driver)*  
The configuration settings and the value specified with the `perform` suboption of the `--RUNTIME` options conflict and a default frequency has been selected.



# Error and Warning Messages

---

**(1313) \* sub-options ("") ignored** **(Driver)**

The argument to a suboption is not required and will be ignored.

```
--OUTPUT=intel:8
```

Oops, the :8 is not required

**(1314) illegal action in memory allocation** **(Code Generator)**

This is an internal error. Contact Microchip Technical Support with details.

**(1315) undefined or empty class used to link psect \*** **(Linker)**

The linker was asked to place a psect within the range of addresses specified by a class, but the class was either never defined, or contains no memory ranges.

**(1316) attribute "" ignored** **(Parser)**

An attribute has been encountered that is valid, but which is not implemented by the parser. It will be ignored by the parser and the attribute will have no effect. Contact Microchip Technical Support with details.

**(1317) missing argument to attribute ""** **(Parser)**

An attribute has been encountered that requires an argument, but this is not present. Contact Microchip Technical Support with details.

**(1318) invalid argument to attribute ""** **(Parser)**

An argument to an attribute has been encountered, but it is malformed. Contact Microchip Technical Support with details.

**(1319) invalid type "" for attribute ""** **(Parser)**

This indicated a bad option passed to the parser. Contact Microchip Technical Support with details.

**(1320) attribute "" already exists** **(Parser)**

This indicated the same attribute option being passed to the parser more than once. Contact Microchip Technical Support with details.

**(1321) bad attribute -T option "%s"** **(Parser)**

The attribute option passed to the parser is malformed. Contact Microchip Technical Support with details.

**(1322) unknown qualifier "%s" given to -T** **(Parser)**

The qualifier specified in an attribute option is not known. Contact Microchip Technical Support with details.

**(1323) attribute expected** **(Parser)**

The `__attribute__` directive was used but did not specify an attribute type.

```
int rv (int a) __attribute__ (()) /* oops -- what is the attribute? */
```

## (1324) qualifier "" ignored (Parser)

Some qualifiers are valid, but cannot be implemented on some compilers or target devices. This warning indicates that the qualifier will be ignored.

## (1325) no such CP\* register: (\$\*), select (\*) (Code Generator)

A variable has been qualified as cp0, but no corresponding co-device register exists at the address specified with the variable.

```
cp0 volatile unsigned int mycpvar @ 0x7000; /* oops --
   did you mean 0x700, try... */
cp0 volatile unsigned int mycpvar @ __REGADDR(7, 0);
```

## (1326) "" qualified variable (\*) missing address (Code Generator)

A variable has been qualified as cp0, but the co-device register address was not specified.

```
cp0 volatile unsigned int mycpvar; /* oops -- what address ? */
```

## (1327) interrupt function "" redefined by "" (Code Generator)

An interrupt function has been written that is linked to a vector location that already has an interrupt function linked to it.

```
void interrupt timer1_isr(void) @ TIMER_1_VCTR { ... }
void interrupt timer2_isr(void) @ TIMER_1_VCTR { ... } /* oops --
   did you mean that to be TIMER_2_VCTR */
```

## (1328) coprocessor \* registers can't be accessed from \* code (Code Generator)

Code in the indicated instruction set has illegally attempted to access the coprocessor registers. Ensure the correct instruction set is used to encode the enclosing function.

## (1329) can only modify RAM type interrupt vectors (Code Generator)

The SETVECTOR() macro has been used to attempt to change the interrupt vector table, but this table is in ROM and cannot be changed at runtime.

## (1330) instruction set architecture qualifiers are only applicable to functions or function pointers (Code Generator)

An instruction set qualifier has been used with something that does not represent executable code.

```
mips16e int input; /* oops -- you cannot qualify a variable with an
instruction set type */
```

## (1331) "" qualifier is not applicable to interrupt functions (Code Generator)

A illegal function qualifier has been used with an interrupt function.

```
mips16e void interrupt t_isr(void) @ CORE_TIMER_VCTR; /* oops --
you cannot use mips16e with interrupt functions */
```

## (1332) invalid qualifier (\*) and type combination on "" (Code Generator)

Some qualified variables must have a specific type or size. A combination has been detected that is not allowed.

```
volatile cp0 int mycpvar @ __REGADDR(7,0); /* oops --
you must use unsigned types with the cp0 qualifier */
```

# Error and Warning Messages

---

- (1333) can't extend instruction** **(Assembler)**
- An attempt was made to extend a MIPS16E instruction where the instruction is non-extensible. This is an internal error. Contact Microchip Technical Support with details.
- (1334) invalid \* register operand** **(Assembler)**
- An illegal register was used with an assembly instruction. Either this is an internal error or caused by hand-written assembly code.
- ```
psect my_text,isa=mips16e,reloc=4
move t0,t1 /* oops -- these registers cannot be used in the
16-bit instruction set */
```
- (1335) instruction "" is deprecated** **(Assembler)**
- An assembly instruction was used that is deprecated.
- ```
beq1 t0,t1,12 /* oops -- this instruction is no longer supported */
```
- (1336) a psect must belong to only one ISA** **(Assembler)**
- Psects that have a flag that defines the allowed instruction set architecture. A psect has been defined whose ISA flag conflicts with that of another definition for the same psect.
- ```
mytext,global,isa=mips32r2,reloc=4,delta=1
mytext,global,isa=mips16e,reloc=4,delta=1 /* oops --
is this the right psect name or the wrong ISA value */
```
- (1337) instruction/macro "" is not part of psect ISA** **(Assembler)**
- An instruction from one instruction set architecture has been found in a psect whose ISA flag specifies a different architecture type.
- ```
psect my_text,isa=mips16e,reloc=4
mtc0 t0,t1 /* oops -- this is a 32-bit instruction */
```
- (1338) operand must be a \* bit value** **(Assembler)**
- The constant operand to an instruction is too large to fit in the instruction field width.
- ```
psect my_text,isa=mips32r2,reloc=4
li t0,0x123456789 /* oops -- this constant is too large */
```
- (1339) operand must be a \* bit \* value** **(Assembler)**
- The constant operand to an instruction is too large to fit in the instruction field width and must have the indicated type.
- ```
addiu a3, a3, 0x123456 /* oops --
the constant operand to this MIPS16E instruction is too large */
```
- (1340) operand must be >= \* and <= \*** **(Assembler)**
- The operand must be within the specified range.
- ```
ext t0,t1,50,3 /* oops -- third operand is too large */
```
- (1341) pos+size must be > 0 and <= 32** **(Assembler)**
- The size and position operands to bit-field instruction must total a value within the specified range.
- ```
ext t0,t1,50,3 /* oops -- 50 + 3 is too large */
```

# MPLAB® XC8 C Compiler User's Guide

---

## (1342) whitespace after "\" (Preprocessor)

Whitespace characters have been found between a *backslash* and *newline* characters and will be ignored.

## (1343) hexfile data at address 0x\* (0x\*) overwritten with 0x\* (Objtohex)

The indicated address is about to be overwritten by additional data. This would indicate more than one section of code contributing to the same address.

## (1346) can't find 0x\* words for psect "" in segment "" (largest unused contiguous range 0x%IX) (Linker)

See also message (491). The new form of message also indicates the largest free block that the linker could find. Unless there is a single space large enough to accommodate the psect, the linker will issue this message. Often when there is banking or paging involved the largest free space is much smaller than the total amount of space remaining,

## (1347) can't find 0x\* words (0x\* withtotal) for psect "" in segment "" (largest unused contiguous range 0x%IX) (Linker)

See also message (593). The new form of message also indicates the largest free block that the linker could find. Unless there is a single space large enough to accommodate the psect, the linker will issue this message. Often when there is banking or paging involved the largest free space is much smaller than the total amount of space remaining,

## (1348) enum tag "" redefined (from \*.\*\*) (Parser)

More than one enum tag with the same name has been defined, The previous definition is indicated in the message.

```
enum VALS { ONE=1, TWO, THREE };
enum VALS { NINE=9, TEN }; /* oops -- is VALS the right tag name? */
```

## (1350) pointer operands to "-" must reference the same array (Code Generator)

If two addresses are subtracted, the addresses must be of the same object to be ANSI compliant.

```
int * ip;
int fred, buf[20];
ip = &buf[0] - &fred; /* oops --
                    second operand must be an address of a "buf" element */
```

## (1352) truncation of operand value (0x\*) to \* bits (Assembler)

The operand to an assembler instruction was too large and was truncated.

```
movlw 0x321 ; oops -- is this the right value?
```

## (1354) ignoring configuration setting for unimplemented word \* (Driver)

A Configuration Word setting was specified for a Word that does not exist on the target device.

```
__CONFIG(3, 0x1234); /* config word 3 does not exist on an 18C801 */
```

## (1355) in-line delay argument too large

(Code Generator)

The in-line delay sequence `_delay` has been used, but the number of instruction cycles requested is too large. Use this routine multiple times to achieve the desired delay length.

```
#include <xc.h>
void main(void) {
    delay(0x400000); /* oops -- cannot delay by this number of cycles */
}
```

## (1356) fixup overflow referencing \*\* (0x\*) into \* byte\* at 0x\*/0x\* -> 0x\* (\*\*\*/0x\*) (Linker)

'Fixup' is the process conducted by the linker of replacing symbolic references to operands with an absolute value. This takes place after positioning the psects (program sections or blocks) into the available memory. 'Fixup overflow' is when a symbol's value is too large to fit within the assembler instruction. For example, if an assembler instruction has an 8-bit field to hold an address and the linker determines that the symbol used to represent this address has the value 0x110, then clearly this value cannot be encoded into the instruction.

Fixup errors are often caused by hand-written assembly code. Common mistakes that trigger these errors include failing to mask a full, banked data address in file register instructions, or failing to mask the destination address in jump or call instructions. If this error is triggered by assembly code generated from C source, then it is often that constructs like `switch()` statements have generated a block of assembly too large for jump instructions to span. Adjusting the default linker options can also cause such errors.

To identify these errors, follow these steps.

- Perform a debug build (in MPLAB X IDE select Debug > Discrete Debugger Operation > Build for Debugging; alternatively, on the command line use the `-D__DEBUG` option)
- Open the relevant assembler list file (ensure the MPLAB X IDE project properties has XC8 Compiler > Preprocessing and Messaging > Generate the ASM listing file enabled; alternatively, on the command line, use the `--ASMLIST` option)
- Find the instruction at the address quoted in the error message

Consider the following error message.

```
main.c: 4: (1356) (linker) fixup overflow referencing psect bssBANK1
(0x100) into 1 byte at 0x7FF0/0x1 -> 0x7FF0 (main.obj 23/0x0)
```

The file being linked was `main.obj`. This tells you the assembly list file in which you should be looking is `main.lst`. The location of the instruction at fault is 0x7FF0. (You can also tell from this message that the instruction is expecting a 1 byte quantity—but this size is rounded to the nearest byte—but the value was determined to be 0x100.)

In the assembly list file, search for the address specified in the error message.

```
61 007FF0 6F00 movwf _foobar,b ;#
```

and to confirm, look for the symbol referenced in the assembler instruction at this address in the symbol table at the bottom of the same file.

```
Symbol Table                                     Tue Oct 28 11:06:37 2014
_foobar 0100
```

# MPLAB® XC8 C Compiler User's Guide

---

In this example, the hand-written PIC18 `MOVWF` instruction causing the problem takes an 8-bit offset into a bank of memory, but clearly the address `0x100` exceeds this size. The instruction should have been written as:

```
MOVWF BANKMASK(_foo)
```

which masks out the top bits of the address containing the bank information, see [Section 6.2.1.3 "Address Masking"](#).

If the assembler instruction that caused this error was generated by the compiler, in the assembler list file look back up the file from the instruction at fault to determine which C statement has generated this instruction. You will then need to examine the C code for possible errors.

## **(1357) fixup overflow storing 0x\* in \* byte\* at 0x\*/0x\* -> 0x\* (\*\*\*/0x\*)** **(Linker)**

See message (1356).

## **(1358) no space for \* temps (\*)** **(Code Generator)**

The code generator was unable to find a space large enough to hold the temporary variables (scratch variables) for this program.

## **(1359) no space for \* parameters** **(Code Generator)**

The code generator was unable to find a space large enough to hold the parameter variables for a particular function.

## **(1360) no space for auto/param \*** **(Code Generator)**

The code generator was unable to find a space large enough to hold the auto variables for a particular function. Some parameters passed in registers can need to be allocated space in this auto area as well.

## **(1361) syntax error in configuration argument** **(Parser)**

The argument to `#pragma config` was malformed.

```
#pragma config WDT /* oops -- is WDT on or off? */
```

## **(1362) configuration setting \*=\* redefined** **(Code Generator)**

The same config pragma setting have been issued more than once with different values.

```
#pragma config WDT=OFF
#pragma config WDT=ON /* oops -- is WDT on or off? */
```

## **(1363) unknown configuration setting (\* = \*) used** **(Driver)**

The configuration value and setting is not known for the target device. The use of an unknown configuration register number may also trigger this message.

```
#pragma config WDR=ON /* oops -- did you mean WDT? */
#pragma config CONFIG1L=0x46 /* oops -- no 1L register on a 18F4520 */
```

## **(1364) can't open configuration registers data file \*** **(Driver)**

The file containing value configuration settings could not be found.

# Error and Warning Messages

---

## (1365) missing argument to pragma "varlocate"

(Parser)

The argument to #pragma varlocate was malformed.  
`#pragma varlocate /* oops -- what do you want to locate & where? */`

## (1366) syntax error in pragma "varlocate"

(Parser)

The argument to #pragma varlocate was malformed.  
`#pragma varlocate fred /* oops -- which bank for fred? */`

## (1367) end of file in \_asm

(Parser)

An end-of-file marker was encountered inside a `_asm _endasm` block.

## (1368) assembler message: \*

(Assembler)

Displayed is an assembler advisory message produced by the `MESSG` directive contained in the assembler source.

## (1369) can't open proc file \*

(Driver)

The proc file for the selected device could not be opened.

## (1370) peripheral library support is not available for the \*

(Driver)

The peripheral library is not available for the selected device.

## (1371) float type can't be bigger than double type; double has been changed to \* bits

(Driver)

Use of the `--float` and `--double` options has result in the size of the `double` type being smaller than that of the `float` type. This is not permitted by the C Standard. The `double` type size has been increased to be that indicated.

## (1372) interrupt level cannot be greater than \*

(Code Generator)

The specific `interrupt_level` is too high for the device selected.  
`#pragma interrupt_level 4`  
`// oops - there aren't that many interrupts on this device`

## (1374) the compiler feature "" is no longer supported; \*

(Driver)

The feature indicated is no longer supported by the compiler.

## (1375) multiple interrupt functions (\* and \*) defined for device with only one interrupt vector

(Code Generator)

The named functions have both been qualified interrupt, but the target device only supports one interrupt vector and hence one interrupt function.

```
interrupt void isr_lo(void) {  
    // ...  
}  
interrupt void isr_hi(void) { // oops, cannot define two ISRs  
    // ...  
}
```

## (1376) initial value (\*) too large for bitfield width (\*) (Code Generator)

A structure with bit-fields has been defined and initialized with values. The value indicated it too large to fit in the corresponding bit-field width.

```
struct {
    unsigned flag :1;
    unsigned mode :3;
} foobar = { 1, 100 }; // oops, 100 is too large for a 3 bit object
```

## (1377) no suitable strategy for this switch (Code Generator)

The compiler was unable to determine the switch strategy to use to encode a C switch statement based on the code and your selection using the `#pragma switch` directive. You can need to choose a different strategy.

## (1378) syntax error in pragma "" (Parser)

The arguments to the indicated pragma are not valid.

```
#pragma addrqual ignore // oops -- did you mean ignore?
```

## (1379) no suitable strategy for this switch (Code Generator)

The compiler encodes `switch()` statements according to one of a number of strategies. The specific number and values of the case values, and the switch expression, as well as the `switch` pragma determine the strategy chosen. This error indicates that no strategy was available to encode the `switch()` statement. Contact Microchip support with program details.

## (1380) unable to use switch strategy "" (Code Generator)

The compiler encodes `switch()` statements according to one of a number of strategies. The specific number and values of the case values, and the switch expression, as well as the `switch` pragma, determine the strategy chosen. This error indicates that the strategy that was requested cannot be used to encode the `switch()` statement. Contact Microchip support with program details.

## (1381) invalid case label range (Parser)

The values supplied for the case range are not correct. They must form an ascending range and be integer constants.

```
case 0 ... -2: // oops -- do you mean -2 ... 0 ?
```

## (1385) \* "" is deprecated (declared at \*:\*) (Parser)

Code is using a variable or function that was marked as being deprecated using an attribute.

```
char __attribute__((deprecated)) foobar;
foobar = 9; // oops -- this variable is near end-of-life
```

## (1386) unable to determine the semantics of the configuration setting "" for register "" (Parser, Code Generator)

The numerical value supplied to a configuration bit setting has no direct association setting specified in the data sheet. The compiler will attempt to honor your request, but check your device data sheet.

```
#pragma config OSC=11
// oops -- there is no direct association for that value on an 18F2520
// either use OSC=3 or OSC=RC
```



# Error and Warning Messages

---

## **(1387) in-line delay argument must be constant** **(Code Generator)**

The `__delay` in-line function can only take a constant expression as its argument.

```
int delay_val = 99;
__delay(delay_val); // oops, argument must be a constant expression
```

## **(1388) configuration setting/register of "" with 0x\* will be truncated by 0x\*** **(Parser, Code Generator)**

A Configuration bit has been programmed with a value that is either too large for the setting, or is not one of the prescribed values.

```
#pragma config WDTPS=138 // oops -- do you mean 128?
```

## **(1389) attempt to reprogram configuration \* "" with \* (is \*)** **(Parser, Code Generator)**

A Configuration bit that was already programmed has been programmed again with a conflicting setting to the original.

```
#pragma config WDT=ON
#pragma config WDT=OFF // oops -- watchdog on or off?
```

## **(1390) identifier specifies insignificant characters beyond maximum identifier length** **(Parser)**

An identifier that has been used is so long that it exceeds the set identifier length. This can mean that long identifiers cannot be correctly identified and the code will fail. The maximum identifier length can be adjusted using the `-N` option.

```
int theValueOfThePortAfterTheModeBitsHaveBeenSet;
// oops, make your symbol shorter or increase the maximum
// identifier length
```

## **(1391) constant object size of \* exceeds the maximum of \* for this chip** **(Code Generator)**

The const object defined is too large for the target device.

```
const int array[200] = { ... }; // oops -- not on a Baseline part!
```

## **(1392) function "" is called indirectly from both mainline and interrupt code** **(Code Generator)**

A function has been called by main-line (non-interrupt) and interrupt code. If this warning is issued, it highlights that such code currently violates a compiler limitation for the selected device.

## **(1393) possible hardware stack overflow detected; estimated stack depth: \*** **(Code Generator)**

The compiler has detected that the call graph for a program could be using more stack space than allocated on the target device. If this is the case, the code can fail. The compiler can only make assumption regarding the stack usage, when interrupts are involved, and these lead to a worst-case estimate of stack usage. Confirm the function call nesting if this warning is issued.

## **(1394) attempting to create memory range ( \* - \* ) larger than page size \* (Driver)**

The compiler driver has detected that the memory settings include a program memory “page” that is larger than the page size for the device. This would mostly likely be the case if the `--ROM` option is used to change the default memory settings. Consult your device data sheet to determine the page size of the device you are using and to ensure that any contiguous memory range you specify using the `--ROM` option has a boundary that corresponds to the device page boundaries.

```
--ROM=100-1fff
```

The above might need to be paged. If the page size is 800h, the above could be specified as

```
--ROM=100-7ff,800-fff,1000-17ff,1800-1fff
```

## **(1395) notable code sequence candidate suitable for compiler validation suite detected (\*) (Code Generator)**

The compiler has in-built checks that can determine if combinations of internal code templates have been encountered. Where unique combinations are uncovered when compiling code, this message is issued. This message is not an error or warning, and its presence does not indicate possible code failure, but if you are willing to participate, the code you are compiling can be sent to Support to assist with the compiler testing process.

## **(1396) "" positioned in the \* memory region (0x\* - 0x\*) reserved by the compiler (Code Generator)**

Some memory regions are reserved for use by the compiler. These regions are not normally used to allocate variables defined in your code. However, by making variables absolute, it is possible to place variables in these regions and avoid errors that would normally be issued by the linker. (Absolute variables can be placed at any location, even on top of other objects.) This warning from the code generator indicates that an absolute has been detected that will be located at memory that the compiler will be reserving. You must locate the absolute variable at a different location. This message will commonly be issued when placing variables in the common memory space.

```
char shared @ 0x7; // oops, this memory is required by the compiler
```

## **(1397) unable to implement non-stack call to ""; possible hardware stack overflow (Code Generator)**

The compiler must encode a C function call without using a CALL assembly instruction and the hardware stack (i.e., use a lookup table), but is unable to. A call instruction might be required if the function is called indirectly via a pointer, but if the hardware stack is already full, an additional call will cause a stack overflow.

## **(1401) eeprom qualified variables can't be accessed from both interrupt and mainline code (Code Generator)**

All eeprom variables are accessed via routines that are not reentrant. Code might fail if an attempt is made to access eeprom-qualified variables from interrupt and main-line code. Avoid accessing eeprom variables in interrupt functions.

## **(1402) a pointer to eeprom can't also point to other data types (Code Generator)**

A pointer cannot have targets in both the EEPROM space and ordinary data space.

# Error and Warning Messages

---

- (1403) pragma "\*" ignored** **(Parser)**
- The pragma you have specified has no effect and will be ignored by the compiler. This message can only be issued in C18 compatibility mode.
- ```
#pragma varlocate "mySection" fred // oops -- not accepted
```
- (1404) unsupported: \*** **(Parser)**
- The unsupported `__attribute__` has been used to indicate that some code feature is not supported.
- The message printed will indicate the feature that is not supported and which should be avoided.
- (1405) storage class specifier "\*" ignored** **(Parser)**
- The storage class you have specified is not required and will be ignored by the compiler. This message can only be issued in C18 compatibility mode.
- ```
int procInput(auto int inValue) // oops -- no need for auto
{ ...
```
- (1406) auto eeprom variables are not supported** **(Code Generator)**
- Variables qualified as `eeprom` cannot be `auto`. You can define `static` local objects qualified as `eeprom`, if required.
- ```
void main(void) {
    eeprom int mode; // oops -- make this static or global
```
- (1407) bit eeprom variables are not supported** **(Code Generator)**
- Variables qualified as `eeprom` cannot have type `bit`.
- ```
eeprom bit myEEbit; // oops -- you cannot define bits in EEPROM
```
- (1408) ignoring initialization of far variables** **(Code Generator)**
- Variables qualified as `far` cannot be assigned an initial value. Assign the value later in the code.
- ```
far int chan = 0x1234; // oops -- you cannot assign a value here
```
- (1409) warning number used with pragma "warning" is invalid** **(Parser)**
- The message number used with the warning pragma is below zero or larger than the highest message number available.
- ```
#pragma warning disable 1316 13350 // oops -- possibly number 1335?
```
- (1410) can't assign the result of an invalid function pointer** **(Code Generator)**
- The compiler will allow some functions to be called via a constant cast to be a function pointer, but not all. The address specified is not valid for this device.
- ```
foobar += ((int (*)(int))0x0)(77);
// oops -- you cannot call a function with a NULL pointer
```
- (1411) Additional ROM range out of bounds** **(Driver)**
- Program memory specified with the `--ROM` option is outside of the on-chip, or external, memory range supported by this device.
- ```
--ROM=default,+2000-2ffff
Oops -- memory too high, should that be 2fff?
```

## (1412) missing argument to pragma "warning disable" (Parser)

Following the `#pragma warning disable` should be a comma-separated list of message numbers to disable.

```
#pragma warning disable // oops -- what messages are to be disabled?
```

Try something like the following.

```
#pragma warning disable 1362
```

## (1413) pointer comparisons involving address of "", positioned at address 0x0, may be invalid (Code Generator)

An absolute object placed at address 0 has had its address taken. By definition, this is a NULL pointer and code which checks for NULL (i.e., checks to see if the address is valid) can fail.

```
int foobar @ 0x00;
int * ip;
```

```
void
main(void)
{
    ip = &foobar; // oops -- 0 is not a valid address
}
```

## (1414) option \* is defunct and has no effect (Driver)

The option used is now longer supported. It will be ignored.

```
xc8 --chip=18f452 --cp=24 main.c
```

Oops -- the `--cp` option is no longer required.

## (1415) argument to "merge" psect flag must be 0 or 1 (Assembler)

This psect flag must be assigned a 0 or 1.

```
PSECT myTxt,class=CODE,merge=true ; oops -- I think you mean merge=1
```

## (1416) psect flag "merge" redefined (Assembler)

A psect with a name seen before specifies a different merge flag value to that previously seen.

```
psect mytext,class=CODE,merge=1
; and later
psect mytext,class=CODE,merge=0
Oops, can mytext be merged or not?
```

## (1417) argument to "split" psect flag must be 0 or 1 (Assembler)

This psect flag must be assigned a 0 or 1.

```
psect mytext,class=CODE,split=5
```

Oops, the `split` flag argument must be 0 or 1.

## (1418) Attempt to read "control" qualified object which is Write-Only (Code Generator)

An attempt was made to read a write-only register.

```
state = OPTION; // oops -- you cannot read this register
```

# Error and Warning Messages

---

## (1419) using the configuration file `*`; you can override this with the environment variable `XC_XML` *(Driver)*

This is the compiler configuration file that is selected during compiler setup. This can be changed via the `XC_XML` environment variable. This file is used to determine where the compiler has been installed. See also, message 1205.

## (1420) ignoring suboption `"*"` *(Driver)*

The suboption you have specified is not valid in this implementation and will be ignored.

```
--RUNTIME=default,+ramtest  
oops -- what is ramtest?
```

## (1421) the qualifier `__xdata` is not supported by this architecture *(Parser)*

The qualifier you have specified is not valid in this implementation and will be ignored.

```
__xdata int coeff[2]; // that has no meaning for this target
```

## (1422) the qualifier `__ydata` is not supported by this architecture *(Parser)*

The qualifier you have specified is not valid in this implementation and will be ignored.

```
__ydata int coeff[2]; // that has no meaning for this target
```

## (1423) case ranges are not supported *(Driver)*

The use of GCC-style numerical ranges in case values does not conform to the CCI Standard. Use individual case labels and values to conform.

```
switch(input) {  
case 0 ... 5: // oops -- ranges of values are not supported  
    low();  
}
```

## (1424) short long integer types are not supported *(Parser)*

The use of the short long type does not conform to the CCI Standard. Use the corresponding `long` type instead.

```
short long typeMod; // oops -- not a valid type for CCI
```

## (1425) `__pack` qualifier only applies to structures and structure members *(Parser)*

The qualifier you have specified only makes sense when used with structures or structure members. It will be ignored.

```
__pack int c; // oops -- there aren't inter-member spaces to pack in  
an int
```

## (1426) 24-bit floating point types are not supported; `*` have been changed to 32-bits *(Driver)*

Floating-point types must be 32-bits wide to conform to the CCI Standard. These types will be compiled as 32-bit wide quantities.

```
--DOUBLE=24
```

oops -- you cannot set this double size

## (1427) machine-dependent path specified in name of included file; use -I instead (Preprocessor)

To conform to the CCI Standard, header file specifications must not contain directory separators.

```
#include <inc\lcd.h>    // oops -- do not indicate directories here
```

Remove the path information and use the -I option to indicate this, for example:

```
#include <lcd.h>
```

and issue the -Ilcd option.

## (1429) attribute "" is not understood by the compiler; this attribute will be ignored (Parser)

The indicated attribute you have used is not valid with this implementation. It will be ignored.

```
int x __attribute__ ((deprecate)) = 0;
```

oops -- did you mean deprecated?

## (1430) section redefined from "" to "" (Parser)

You have attempted to place an object in more than one section.

```
int __section("foo") __section("bar") myvar; // oops -- which section
should it be in?
```

## (1431) the \_\_section specifier is applicable only to variable and function definitions at file-scope (Parser)

You cannot attempt to locate local objects using the \_\_section() specifier.

```
int main(void) {
    int __section("myData") counter; // oops -- you cannot specify a
section for autos
```

## (1432) "" is not a valid section name (Parser)

The section name specified with \_\_section() is not a valid section name. The section name must conform to normal C identifier rules.

```
int __section("28data") counter; // oops -- name cannot start
with digits
```

## (1433) function "" could not be inlined (Assembler)

The specified function could not be made in-line. The function will be called in the usual way.

```
int inline getData(int port) // sorry -- no luck inlining this
{ //...
```

## (1434) missing name after pragma "intrinsic" (Parser)

The intrinsic pragma needs a function name. This pragma is not needed in most situations. If you mean to in-line a function, see the inline keyword or pragma.

```
#pragma intrinsic // oops -- what function is intrinsically called?
```

# Error and Warning Messages

---

## (1435) variable "" is incompatible with other objects in section "" (Code Generator)

You cannot place variables that have differing startup initializations into the same psect. That is, variables that are cleared at startup and variables that are assigned an initial non-zero value must be in different psects. Similarly, `bit` objects cannot be mixed with byte objects, like `char` or `int`.

```
int __section("myData") input;    // okay
int __section("myData") output;  // okay
int __section("myData") lvl = 0x12; // oops -- not with uninitialized
bit __section("myData") mode;    // oops again -- no bits with bytes
// each different object to their own new section
```

## (1436) "" is not a valid nibble; use hexadecimal digits only (Parser)

When using `__IDLOC()`, the argument must only consist of hexadecimal digits with no radix specifiers or other characters. Any character which is not a hexadecimal digit will be programmed as a 0 in the corresponding location.

```
__IDLOC(0x51); // oops -- you cannot use the 0x radix modifier
```

## (1437) CMF error \* (Cromwell)

The CMF file being read by Cromwell is invalid. Unless you have modified or generated this file, this is an internal error. Contact Microchip Technical Support with details.

## (1438) pragma "" options ignored (Parser)

You have used unsupported options with a pragma. The options will be ignored.

```
#pragma inline=forced // oops -- no options allowed with this pragma
```

## (1439) message: \* (Parser)

This is a programmer generated message; there is a pragma directive causing this advisory to be printed. This is only printed when using IAR C extensions.

```
#pragma message "this is a message from your programmer"
```

## (1440) big-endian storage is not supported by this compiler (Parser)

You have specified the `__big_endian` IAR extension for a variable. The big-endian storage format is not supported by this compiler. Remove the specification and ensure that other code does not rely on this endianism.

```
__big_endian int volume; // oops -- this won't be big endian
```

## (1441) use \_\_at() instead of '@' and ensure the address is applicable (Parser)

You have used the `@ address` specifier when using the IAR C extensions. Any address specified is unlikely to be correct on a new architecture. Review the address in conjunction with your device data sheet. To prevent this warning from appearing again, use the reviewed address with the `__at()` specifier instead.

## **(1442) type used in definition is incomplete** **(Parser)**

When defining objects, the type must be complete. If you attempt to define an object using an incomplete type, this message is issued.

```
typedef struct foo foo_t;
foo_t x; // oops -- you cannot use foo_t until it is fully defined

struct foo {
    int i;
};
```

## **(1443) unknown --EXT sub-option ""** **(Driver)**

The suboption to the --EXT option is not valid.

```
xc8 --chip=18f8585 x.c --ext=arm --ext=cci
Oops -- valid choices are iar, cci and xc8
```

## **(1444) respecified C extension from "" to ""** **(Driver)**

The --EXT option has been used more than once, with conflicting arguments. The last use of the option will dictate the C extensions accepted by the compiler.

```
xc8 --chip=18f8585 x.c --ext=iar --ext=cci
Oops -- which C extension do you mean?
```

## **(1445) #advisory: \*** **(Preprocessor)**

This is a programmer generated message; there is a directive causing this advisory to be printed.

```
#advisory "please listen to this good advice"
```

## **(1446) #info: \*** **(Preprocessor)**

This is a programmer generated message; there is a directive causing this advisory to be printed. It is identical to #advisory messages (1445).

```
#info "the following is for your information only"
```

## **(1447) extra -L option (-L\*) ignored** **(Preprocessor)**

This error relates to a duplicate -L option being passed to the preprocessor. Unless you are explicitly running this application, consider this an internal error. Contact Microchip Technical Support with details.

## **(1448) no dependency file type specified with -L option** **(Preprocessor)**

This error relates to a malformed -L option being passed to the preprocessor. Unless you are explicitly running this application, consider this an internal error. Contact Microchip Technical Support with details.

## **(1449) unknown dependency file type (\*)** **(Preprocessor)**

This error relates to a unknown dependency file format being passed to the preprocessor. Unless you are explicitly running this application, consider this an internal error. Contact Microchip Technical Support with details.



# Error and Warning Messages

---

- (1450) invalid --\*-spaces argument (\*)** **(Cromwell)**
- The option passed to Cromwell does not relate to a valid memory space. The space arguments must be a valid number that represents the space.
- ```
--data-spaces=a
```
- Oops — a is not a valid data space number.
- (1451) no \* spaces have been defined** **(Cromwell)**
- Cromwell must be passed information that indicates the type for each numbered memory space. This is done via the `--code-spaces` and `--data-spaces` options. Unless you are explicitly running this application, consider this an internal error. Contact Microchip Technical Support with details.
- (1452) one or more spaces are defined as data and code** **(Cromwell)**
- The options passed to Cromwell indicate memory space is both in the code and data space. Unless you are explicitly running this application, consider this an internal error. Contact Microchip Technical Support with details.
- ```
--code-space=1,2 --data-space=1
```
- Oops — is space 1 code or data?
- (1453) stack size specified for non-existent \* interrupt** **(Driver)**
- The `--STACK` option has been used to specify the maximum sizes for each stack. A size has been used for each interrupt, but the compiler cannot see the corresponding interrupt function definition, which means the stack space can never be used. Ensure that you create the interrupt function for each interrupt the device supports.
- ```
--STACK=reentrant:20:20:auto
```
- Oops, you have asked for two interrupt stacks, but the compiler cannot see both interrupt function definitions.
- (1454) stack size specified (\*) is greater than available (\*)** **(Driver)**
- The `--STACK` option has been used to specify the maximum sizes for each stack, but the total amount of memory requested exceeds the amount of memory available.
- ```
--STACK=software:1000:1000:20000
```
- Oops, that is too much stack space for a small device.
- (1455) unrecognized stack size "\*" in "\*" **(Driver)****
- The `--STACK` option has been used to specify the maximum sizes for each stack, but one or more of the sizes are not a valid value. Use only decimal values in this option, or the token `auto`, for a default size.
- ```
--STACK=software:30:all:default
```
- Oops, only use decimal numbers or `auto`.
- (1456) too many stack size specifiers** **(Driver)**
- Too many software stack maximum sizes have been specified in the `--STACK` option. The maximum stack sizes are optional. If used, specify one size for each interrupt and one for main-line code.
- ```
--STACK=reentrant:20:20:auto
```
- Oops, too many sizes for a device with only one interrupt.

**(1457) local variable "" cannot be made absolute** **(Code Generator)**

You cannot specify the address of any local variable, whether it be an auto, parameter, or static local object.

```
int pushState(int a) {  
int cnt __at(0x100); // oops -- you cannot specify an address ...
```

**(1458) Omniscient Code Generation not available in Standard mode** **(Driver)**

This message warns you that not all optimizations are enabled in the Standard operating mode.

**(1459) peripheral library support is missing for the \*** **(Driver)**

The peripheral libraries do not have code present for the device you have selected. Disable the option that links in the peripheral library.

**(1460) function-level profiling is not available for the selected chip** **(Driver)**

Function profiling is only available for PIC18 or enhanced mid-range devices. If you are not using such a device, do not attempt to use function profiling.

**(1461) insufficient h/w stack to profile function ""** **(Code Generator)**

Function profiling requires a level of hardware stack. The entire stack has been used by this program so not all functions can be profiled. The indicated function will not have profiling code embedded into it, and it will not contribute to the profiling information displayed by MPLAB X IDE.

**(1462) reentrant data stack model option conflicts with stack management option and will be ignored** **(Code Generator)**

The managed stack option allows conversion of function calls that would exceed the hardware stack depth to calls that will use a lookup table. This option cannot be enabled if the reentrant function model is also enabled. If you attempt to use both the managed stack and reentrant function model options, this message will be generated. Code will be compiled with the stack management option disabled. Either disable the reentrant function model or the managed stack option.

**(1463) reentrant data stack model not supported on this device; using compiled stack for data** **(Code Generator)**

The target device does not support reentrant functions. The program will be compiled so that stack-based data is placed on a compiled stack.

**(1464) number of arguments passed to function "" does not match function's prototype** **(Code Generator)**

A function was called with arguments, but the definition of the function had an empty parameter list (as opposed to a parameter list of `void`).

```
int test(); // oops--this should define the parameters  
...  
test(12, input);
```

# Error and Warning Messages

---

## (1465) the stack frame size for function "" (\* bytes) has exceeded the maximum allowable (\* bytes) (Code Generator)

The compiler has been able to determine that the software stack requirements for the named function's auto, parameter, and temporary variables exceed the maximum allowable. The limits are 31 for enhanced mid-range devices and 127 for PIC18 devices. Reduce the size or number of these variables. Consider static local objects instead of auto objects.

```
reentrant int addOffset(int offset) {
int report[400]; // oops--this will never fit on the software stack
```

## (1466) registers \* unavailable for code generation of this expression (Code Generator)

The compiler has been unable to generate code for this statement. This is essentially a "can't generate code" error message (message 712), but the reason for this inability to compile relates to there not being enough registers available. See message 712 for suggested workarounds.

## (1467) pointer used for writes includes read-only target "" (Code Generator)

A pointer to a non-`const` qualified type is being used to write a value, but the compiler knows that this pointer has targets (the first of which is indicated) that have been qualified `const`. This could lead to code failure or other error messages being generated.

```
void keepTotal(char * cp) {
    *cp += total;
}
char c;
const char name[] = "blender";
keepTotal(&c);
keepTotal(&name[2]); // oops--will write a read-only object
```

## (1468) unknown ELF/DWARF specification (\*) in --output option (Driver)

The ELF suboption uses flags that are unknown.

```
--output=elf:3
```

Oops, there is no `elf` flag of 3.

This ELF suboption and its flags are usually issued by the MPLAB X IDE plugin. Contact Microchip Technical Support with details of the compiler and IDE if this error is issued.

## (1469) function specifier "reentrant/software" used with "" ignored (Code Generator)

The `reentrant` (or `software`) specifier was used with a function (indicated) that cannot be encoded to use the software stack. The specifier will be ignored and the function will use the compiled stack.

```
reentrant int main(void) // oops--main cannot be reentrant
...
```

## (1470) trigraph sequence "???" replaced (Preprocessor)

The preprocessor has replaced a trigraph sequence in the source code. Ensure you intended to use a trigraph sequence.

```
char label[] = "What??!"; // you do know that's a trigraph
// sequence, right?
```

## (1471) indirect function call via a NULL pointer ignored (Code Generator)

The compiler has detected a function pointer with no valid target other than NULL. That pointer has been used to call a function. The call will not be made.

```
int (*fp)(int, int);
result = fp(8,10); // oops--this pointer has not been initialized
```

## (1472) --CODEOFFSET option ignored: \* (Driver)

The compiler is ignoring an invocation of the `--CODEOFFSET` option. The printed description will indicate whether the option is being ignored because the compiler has seen this option previously or the compilation mode does not support its use.

## (1474) read-only target "\*" may be indirectly written via pointer (Code Generator)

This is the same as message 1467, but for situations where an error is required. The compiler has encountered a pointer that is used to write, and one or more of the pointer's targets are read-only.

```
const char c = 'x';
char * cp = &c; // will produce warning 359 about address assignment
*cp = 0x44;     // oops--you ignored the warning above, now you are
               // actually going to write using the pointer?
```

## (1478) initial value for "\*" differs to that in \*.\* (Code Generator)

The named object has been defined more than once and its initial values do not agree. Remember that uninitialized objects of static storage duration are implicitly initialized with the value zero (for all object elements or members, where appropriate).

```
char myArray[5] = { 0 };
// elsewhere
char myArray[5] = {0,2,4,6,8}; // oops--previously initialized
                             // with zeros, now with different values
```

## (1479) EEPROM data not supported by this device (Parser)

The `eeeprom` qualifier was used but there is no EEPROM on the target device. Any instances of this qualifier will be ignored.

```
eeeprom int serialNo; // oops--no EEPROM on this device
```

## (1480) initial value(s) not supplied in braces; zero assumed (Code Generator)

The assignment operator was used to indicate that the object was to be initialized, but no values were found in the braces. The object will be initialized with the value(s) 0.

```
int xy_map[3][3] = { }; // oops--did you mean to supply values?
```

## (1481) call from non-reentrant function, "\*", to "\*" might corrupt parameters (Code Generator)

If several functions can be called indirectly by the same function pointer, they are called 'buddy' functions, and the parameters to buddy functions are aligned in memory. This allows the parameters to be loaded without knowing exactly which function was called by the pointer (as is often the case). However, this means that the buddy functions cannot directly or indirectly call each other.

```
// fpa can call any of these, so they are all buddies
int (*fpa[])(int) = { one, two, three };
int one(int x) {
```

# Error and Warning Messages

---

```
    return three(x+1); // oops--one() cannot call buddy three()
}
```

## (1482) absolute object \* overlaps \*

(Linker)

The reservation for an absolute object has been found to overlap with the memory reserved by another absolute object.

```
unsigned char nfo[6] @ 0x80;
unsigned char nfo2[6] @ 0x7b; //oops--this overlaps nfo
```

## (1483) \_\_pack qualifier ignored

(Parser)

The \_\_pack qualifier has no affect on auto or static local structures and has been ignored.

```
int setInput(void) {
    __pack struct { //oops--this will not be packed
        unsigned x, y;
    } inputData;
}
```

## (1484) the branch errata option is turned on and a BRW instruction was detected

(Assembler)

The use of this instruction may cause code failure with the selected device. Check the published errata for your device to see if this restriction is applicable for your device revision. If so, remove this instruction from hand-written assembly code.

```
btfs status,2
brw next ;oops--this instruction cannot be safely used
call update
```

## (1485) \* mode is not available with the current license and other modes are not permitted by the NOFALLBACK option

(Driver)

This compiler's license does not allow the requested compiler operating mode. Since the --NOFALLBACK option is enabled, the compiler has produced this error and will not fall back to a lower operating mode. If you believe that you are entitled to use the compiler in the requested mode, this error indicates that your compiler might not be activated correctly.

## (1486) size of pointer cannot be determined during preprocessing. Using default size \*

(Preprocessor)

The preprocessor cannot determine the size of pointer type. Do not use the sizeof operator in expressions that need to be evaluated by the preprocessor.

```
#if sizeof(int *) == 3 // oops - you can't take the size of a
pointer type
#define MAX 40
#endif
```

**(1488) the stack frame size for function "\*" may have exceeded the maximum allowable (\* bytes) (Code Generator)**

This message is emitted in the situation where the indicated function's software-stack data has exceeded the theoretical maximum allowable size. Data outside this stack space will only be accessible by some instructions that could attempt to access it. In some situations the excess data can be retrieved, your code will work as expected, and you can ignore this warning. This is likely if the function calls a reentrant function that returns a large object, like a structure, on the stack. At other times, instructions that are unable to access this data will, in addition to this warning, trigger an error message at the assembly stage of the build process, and you will need to look at reducing the amount of stack data defined by the function.

**(1489) unterminated IF directive at end of psect \* (Assembler)**

The assembler has reached the end of the named psect and not seen the terminating `ENDIF` directive associated with the last `IF` or `ELSIF` directive previously encountered.

```
psect mytext, class=CODE, reloc=2
    movlw 20h
IF TEST_ONLY
    movlw 00h
    movwf _mode, c ; oops--where does the IF end?
psect nexttext, class=CODE, reloc=2
```

**(1490) ENDIF not inside an IF directive (Assembler)**

The assembler has encountered an `ENDIF` directive that does not have any corresponding `IF` or `ELSIF` directive.

```
psect mytext, class=CODE, reloc=2
    movlw 20h
IF TEST_ONLY
    movlw 00h
ENDIF
ENDIF; oops--what does this terminate?
```

**(1491) runtime sub-option "\*" is not available for this device (Driver)**

A specified suboption to the `--RUNTIME` option is not available for the selected device.

```
xc8 --CHIP=MCP19114 --RUNTIME=+osccal main.c
```

Oops, the `osccal` suboption is not available for this device.

**(1492) using updated 32-bit floating-point libraries; improved accuracy might increase code size (Code Generator)**

This advisory message ensures you are aware of the changes in 32-bit floating-point library code operation that might lead to an increase in code size.

**(1493) updated 32-bit floating-point routines might trigger "can't find space" messages appearing after updating to this release; consider using the smaller 24-bit floating-point types (Linker)**

This advisory message ensures you are aware of the changes in 32-bit floating-point library code operation which might lead to the Can't Find Space error message that has been issued.

# Error and Warning Messages

---

## **(1494) invalid argument to normalize32** **(Assembler)**

The NORMALIZE32 operator has been used on an operand that is not a literal constant.  
`NORMALIZE(_foobar) ; oops--that must be a literal constant operand`

## **(1495) ADDFSR/SUBFSR instruction argument must be 0-3** **(Assembler)**

The operand to this instruction must be a literal constant and in the range 0 to 3, inclusive.

`addfsr 1, 6 ; oops--the offset must be between 0 to 3`

## **(1496) arithmetic on pointer to void yields Undefined Behavior** **(Code Generator)**

Performing operations on pointers requires the size of the pointed-to object, which is not known in the case of generic (`void *`) pointers.

`void * vp;`

`vp++; // oops--how can this be incremented without knowing what it points to?`

## **(1497) more than one \*interrupt function defined** **(Code Generator)**

Only one interrupt function of the same priority can be defined.

```
void interrupt lo_isr(void) { // oops - was this meant to be a
low_priority interrupt?
...
}
```

```
void interrupt hi_isr(void) {
...
}
```

## **(1498) pointer (\*) in expression may have no targets** **(Code Generator)**

A pointer that contains NULL has been dereferenced. Assign the pointer a valid address before doing so.

`char * cp, c;`

`c = *cp; // oops --what is cp pointing to?`

## **(1499) only decimal floating-point constants can be suffixed "f" or "F"**

The floating-point constant suffix has been used with an integer value.

`float myFloat = 100f*3.2; // oops - is '100f' mean to be a hex or floating-point value?`

# MPLAB® XC8 C Compiler User's Guide

---

## MESSAGES 1500-1749

### (1500) invalid token in #if expression

*(Preprocessor)*

There is a malformed preprocessor expression.

```
#define LABEL
#define TEST 0

#if (LABEL == TEST) // oops--LABEL has no replacement text
```

### (1504) the PIC18 extended instruction set was enabled but is not supported by this compiler

*(Parser)*

The MPLAB XC8 compiler does not support generation of code using the PIC18 extended instruction set. The extended instruction set configuration bit must always be disabled.

```
#pragma config XINST=ON // oops--this must be disabled at all times
```

### (1505) interrupts not supported by this device

*(Code Generator)*

You have attempted to define an interrupt function for a device that does not support interrupts.

```
void interrupt myIsr(void) // oops--nothing will trigger this
{ ... }
```

### (1506) multiple interrupt functions (\* and \*) defined at interrupt level \* *(Code Generator)*

More than one interrupt function has been defined for the same priority.

```
void interrupt low_priority
isr(void)
{ ... }

void interrupt low_priority// oops--you can have two ISRs
loisr(void) // with the same priority
{ ... }
```

### (1507) asmopt state popped when there was no pushed state

*(Assembler)*

The state of the assembler optimizers was popped in assembly code but there was no corresponding push.

```
movlw 20h
movwf LATB
opt asmopt_pop; oops--there was never a state pushed
```

### (1511) stable/invariant mode optimizations no longer implemented; option will be ignored *(Driver)*

This option is no longer available and has been ignored.

### (1512) stable/invariant mode optimizations no longer implemented; specifier will be ignored *(Code Generator)*

This specifier is no longer available and has been ignored.



# Error and Warning Messages

---

## MESSAGES 2000-2249

### (2000) \* attribute/specifier has a misplaced keyword (\*) (Parser)

An attribute token has been used in a context where it was not expected.

```
// oops -- 'base' is a token which has specific meaning
void __interrupt(irq(base)) isr(void)
```

### (2001) \* attribute/specifier has a misplaced parenthesis (Parser)

The parentheses used in this attribute construct are not correctly formed. Check to ensure that you do not have extra brackets and that they are in the correct position.

```
void __interrupt(irq((TMR0)) isr(void) // oops -- one too many '('s
```

### (2002) \_\_interrupt attribute/specifier has conflicting priority-levels (Parser)

More than one priority has been assigned to an interrupt function definition.

```
//oops -- is it meant to be low or high priority?
void __interrupt(irq(TMR0), high_priority, low_priority) tc0Int(void)
```

### (2003) \* attribute/specifier has a duplicate keyword (\*) (Parser)

The same token has been used more than once in this attribute. Check to ensure that one of these was not meant to be something else.

```
//oops -- using high_priority twice has no special meaning
void __interrupt(irq(TMR0), high_priority, high_priority) tc0Int(void)
```

### (2004) \_\_interrupt attribute/specifier has an empty "irq" list (Parser)

The `irq()` argument to the `__interrupt()` specifier takes a comma-separated list of interrupt vector numbers or symbols. At least one value or symbol must be present to link this function to the interrupt source.

```
//oops -- irq() does not indicate the interrupt source
void __interrupt(irq(),high_priority) tc0Int(void)
```

### (2005) \_\_interrupt attribute/specifier has an empty "base" list (Parser)

The `base()` argument to the `__interrupt()` specifier is optional, but when used it must take a comma-separated list of interrupt vector table addresses. At least one address must be present to position the vector table. If you do not specify the base address with an ISR, its vector will be located in an interrupt vector table located at an address equal to the reset value of the IVTBASE register.

```
//oops -- base() was used but did not indicate a vector table address
void __interrupt(irq(TMR0), base()) tc0Int(void)
```

### (2006) \_\_interrupt attribute/specifier has a duplicate "irq" (\*) (Parser)

An `irq()` argument to the `__interrupt()` specifier has been used more than once.

```
//oops -- is one of those sources wrong?
void __interrupt(irq(TMR0,TMR0)) tc0Int(void)
```

### (2007) \_\_interrupt attribute/specifier has a duplicate "base" (\*) (Parser)

The same `base()` argument to the `__interrupt()` specifier has been used more than once.

```
//oops -- is one of those base addresses wrong?
void __interrupt(irq(TMR0), base(0x100,0x100)) tc0Int(void)
```

# MPLAB® XC8 C Compiler User's Guide

---

## (2008) unknown "irq" (\*) in \_\_interrupt attribute/specifier (Parser)

The interrupt symbol or number used with the irq() argument to the \_\_interrupt() specifier does not correspond with an interrupt source on this device.

```
//oops -- what interrupt source is TODO?
void __interrupt(irq(TODO),high_priority) tc0Int(void)
```

## (2009) \* attribute/specifier has a misplaced number (\*) (Parser)

A numerical value appears in an attribute where it is not expected.

```
//oops -- this specifier requires specific argument, not a number
void __interrupt(0) isr(void)
```

## (2010) \_\_interrupt attribute/specifier contains a misplaced interrupt source name (\*) (Parser)

An interrupt source name can only be used as an argument to irq().

```
//oops -- base() needs a vector table address
void __interrupt(irq(TMR0), base(TMR0)) tc0Int(void)
```

## (2011) \_\_interrupt attribute/specifier has a base (\*) not supported by this device (Parser)

The address specified with the base() argument to the \_\_interrupt() specifier is not valid for the target device. It cannot, for example, be lower than the reset value of the IVTBASE register.

```
//oops -- the base() address is too low
void __interrupt(irq(TMR0), base(0x00)) tc0Int(void)
```

## (2012) \* attribute/specifier is only applicable to functions (Parser)

The \_\_interrupt() specifier has been used with something that is not a function.

```
// oops -- foobar is an int, not an ISR
__interrupt(irq(TMR0)) int foobar;
```

## (2013) argument "" used by "" attribute/specifier not supported by this device (Parser)

The argument of the indicated specifier is not valid for the target device.

```
// oops -- base() can't be used with a device that does not
// support vectored interrupts
void __interrupt(base(0x100)) myMidrangeISR(void)
```

## (2014) interrupt vector table @ 0x\* already has a default ISR "" (Code Generator)

You can indicate only one default interrupt function for any vector location not specified in a vector table. If you have specified this twice, check to make sure that you have specified the correct base() address for each default.

```
void __interrupt(irq(default), base(0x100)) tc0Int(void) { ...
void __interrupt(irq(default), base(0x100)) tc1Int(void) { ...
// oops -- did you mean to use different different base() addresses?
```

## (2015) interrupt vector table @ 0x\* already has an ISR (\*) to service IRQ \* (\*) (Parser or Code Generator)

You have specified more than one interrupt function to handle a particular interrupt source in the same vector table.

```
void __interrupt(irq(TMR0), base(0x100)) tc0Int(void) { ...
void __interrupt(irq(TMR0), base(0x100)) tc1Int(void) { ...
```

# Error and Warning Messages

---

```
// oops -- did you mean to use different different base() addresses?
```

## (2016) interrupt function "" does not service any interrupt sources (Code Generator)

You have defined an interrupt function but did not indicate which interrupt source this function should service. Use the `irq()` argument to indicate the source or sources.

```
//oops -- what interrupt does this service?
void __interrupt(low_priority, base(0x100)) tc0Int(void)
```

## (2017) config programming has disabled multi-vectors, "irq" in \_\_interrupt attribute/specifier is ignored (Code Generator)

An interrupt function has used the `irq()` argument to specify an interrupt source, but the vector table has been disabled via the configuration bits. Either re-enable vectored interrupts or use the `priority` keyword in the `__interrupt()` specifier to indicate the interrupt source.

```
#pragma config MVECEN=0
void __interrupt(irq(TMR0), base(0x100)) tc0Int(void)
// oops -- you cannot disable the vector table then allocate interrupt
// functions a vector source using irq()
```

## (2018) interrupt vector table @ 0x\* has multiple functions (\* and \*) defined at interrupt level \* (Code Generator)

The program for a device operating in legacy mode has specified a vector table that contains more than one function at the same interrupt priority-level in the same table. In this mode, there can be at most one interrupt function for each priority level in each vector table.

```
#pragma config MVECEN=0
void __interrupt(high_priority) tc0Int(void) {...}
void __interrupt(high_priority) tc1Int(void) {...}
```

## (2019) \* interrupt vector in table @ 0x\* is unassigned, will be programmed with a \* (Code Generator)

In a program for a device operating in legacy mode, an interrupt vector in the indicated vector table has not been programmed with an address. The compiler will program this vector with an address as specified by the `--UNDEFINTS` option.

## (2020) IRQ \* (\*) in vector table @ 0x\* is unassigned, will be programmed with the address of a \* (Code Generator)

The interrupt vector in the indicated vector table has not been programmed with an address. The compiler will program this vector with an address as specified by the `--UNDEFINTS` option.

## (2021) invalid runtime "" sub-option argument (\*) (Driver)

The argument to a sub-option specified with the `--RUNTIME` option is not valid.

```
--RUNTIME=default,+ivt:reset
```

Oops, the `ivt` suboption requires a numeric address as its argument.

## (2022) runtime sub-option "ivt" specifies a base address (0x\*) not supported by this device (Driver)

The address specified with the `ivt` sub-option is not valid for the selected target device. It cannot, for example, be lower than the reset value of the `IVTBASE` register.

## (2023) IVT @ 0x\* will be selected at startup

(Code Generator)

The source code defines more than one IVT and no address was specified with the `ivt` sub-option to the `--RUNTIME` option to indicate which table should be selected at startup. The IVT with the lowest address will be selected by the compiler. It is recommended that you always specify the table address when using this option.

## (2024) runtime sub-option "ivt" specifies an interrupt table (@ 0x\*) that has not been defined

(Driver)

The `ivt` sub-option to the `--RUNTIME` option was used to specify a IVT address, but this address has not been specified in the source code with any ISR. Check that the address in the option is correct, or check that the `base()` arguments to the `__interrupt()` specifier are specified and are correct.

```
--RUNTIME=+ivt:0x100
```

Oops -- is this the right address? Nothing in the source code uses this base address.

## (0) delete what ?

(Libr)

The Librarian requires one or more modules to be listed for deletion when using the `d` key, for example:

```
libr d c:\ht-pic\lib\pic704-c.lib
```

does not indicate which modules to delete. try something like:

```
libr d c:\ht-pic\lib\pic704-c.lib wdiv.obj
```

## (0) incomplete ident record

(Libr)

The IDENT record in the object file was incomplete. Contact Microchip Technical Support with details.

## (0) incomplete symbol record

(Libr)

The SYM record in the object file was incomplete. Contact Microchip Technical Support with details.

## (0) library file names should have.lib extension: \*

(Libr)

Use the `.lib` extension when specifying a library filename.

## (0) module \* defines no symbols

(Libr)

No symbols were found in the module's object file. This can be what was intended, or it can mean that part of the code was inadvertently removed or commented.

## (0) replace what ?

(Libr)

The Librarian requires one or more modules to be listed for replacement when using the `r` key, for example:

```
libr r lcd.lib
```

This command needs the name of a module (`.obj` file) after the library name.

---

---

## Appendix D. Implementation-Defined Behavior

---

---

### D.1 INTRODUCTION

This section discusses implementation-defined behavior for this implementation of the MPLAB XC8 C Compiler. The exact behavior of some C code can vary from compiler to compiler, and the ANSI standard for C requires that vendors document the specifics of implementation-defined features of the language.

The number in brackets after each item refers to the section number in the Standard to which the item relates.

### D.2 TRANSLATION (G.3.1)

#### D.2.1 How a diagnostic is identified (5.1.1.3)

The format of diagnostics is fully controllable by the user. By default, when compiling on the command-line the following formats are used. Always indicated in the display is a unique message ID number. The string *(warning)* is only displayed if the message is a warning.

```
filename: function()  
linenumber:source line  
^ (ID) message (warning)
```

or

```
filename: linenumber: (ID) message (warning)
```

where *filename* is the name of the file that contains the code (or empty if no particular file is relevant); *linenumber* is the line number of the code (or 0 if no line number is relevant); *ID* is a unique number that identifies the message; and *message* is the diagnostic message itself.

### D.3 ENVIRONMENT (G.3.2)

#### D.3.1 The semantics of arguments to main (5.1.2.2.1)

The function `main` has no arguments, nor return value. It follows the prototype:

```
void main(void);
```

## D.4 IDENTIFIERS (G.3.3)

### D.4.1 The number of significant initial characters (beyond 31) in an identifier without external linkage (6.1.2)

By default, the first 31 characters are significant. This can be adjusted up to 255 by the user.

### D.4.2 The number of significant initial characters (beyond 6) in an identifier with external linkage (6.1.2)

By default, the first 31 characters are significant. This can be adjusted up to 255 by the user.

### D.4.3 Whether case distinctions are significant in an identifier with external linkage (6.1.2)

All characters in all identifiers are case sensitive.

## D.5 CHARACTERS (G.3.4)

### D.5.1 The members of the source and execution character sets, except as explicitly specified in the Standard (5.2.1)

Both sets are identical to the ASCII character set.

### D.5.2 The shift states used for the encoding of multibyte characters (5.2.1.2)

There are no shift states.

### D.5.3 The number of bits in a character in the execution character set (5.2.4.2.1)

There are 8 bits in a character.

### D.5.4 The mapping of members of the source character set (in character and string literals) to members of the execution character set (6.1.3.4)

The mapping is the identity function.

### D.5.5 The value of an integer character constant that contains a character or escape sequence not represented in the basic execution character set or the extended character set for a wide character constant (6.1.3.4)

It is the numerical value of the rightmost character.

### D.5.6 The value of an integer character constant that contains more than one character, or a wide character constant that contains more than one multibyte character (3.1.3.4)

Not supported.

### D.5.7 Whether a plain char has the same range of values as signed char or unsigned char (6.2.1.1)

A plain `char` is treated as an `unsigned char`.

## D.6 INTEGERS (G.3.5)

### D.6.1 The representations and sets of values of the various types of integers (6.1.2.5)

See [Section 5.4.2 “Integer Data Types”](#).

### D.6.2 The result of converting an integer to a shorter signed integer, or the result of converting an unsigned integer to a signed integer of equal length, if the value cannot be represented (6.2.1.2)

The low-order bits of the original value are copied to the signed integer; or, all the low-order bits of the original value are copied to the signed integer.

### D.6.3 The results of bitwise operations on signed integers (6.3)

The bitwise operations act as if the operand was `unsigned`.

### D.6.4 The sign of the remainder on integer division (6.3.5)

The remainder has the same sign as the dividend. [Table D-1](#) shows the expected sign of the result of division for all combinations of dividend and divisor signs.

In the case where the second operand is zero (division by zero), the result will always be zero.

**TABLE D-1: INTEGRAL DIVISION**

| Dividend | Divisor | Quotient | Remainder |
|----------|---------|----------|-----------|
| +        | +       | +        | +         |
| -        | +       | -        | -         |
| +        | -       | -        | +         |
| -        | -       | +        | -         |

### D.6.5 The result of a right shift of a negative-valued signed integral type (6.3.7)

The right shift operator sign extends signed values. Thus, an object with the `signed int` value `0x0124` shifted right one bit will yield the value `0x0092` and the value `0x8024` shifted right one bit will yield the value `0xC012`.

Right shifts of `unsigned` integral values always clear the MSb of the result.

Left shifts (`<<` operator), `signed` or `unsigned`, always clear the LSb of the result.

## D.7 FLOATING-POINT (G.3.6)

### D.7.1 The representations and sets of values of the various types of floating-point numbers (6.1.2.5)

See [Section 5.4.3 “Floating-Point Data Types”](#).

### D.7.2 The direction of truncation when an integral number is converted to a floating-point number that cannot exactly represent the original value (6.2.1.3)

The integer value is rounded to the nearest floating-point value that can be represented.

### D.7.3 The direction of truncation or rounding when a floating-point number is converted to a narrower floating-point number (6.2.1.4)

The floating-point number is truncated to the smaller floating-point number.

## D.8 ARRAYS AND POINTERS (G.3.7)

### D.8.1 The type of integer required to hold the maximum size of an array; that is, the type of the sizeof operator, `size_t` (6.3.3.4, 7.1.1)

The type of `size_t` is `unsigned int`.

### D.8.2 The result of casting a pointer to an integer, or vice versa (6.3.4)

When casting an integer to a pointer variable, if the pointer variable throughout the entire program is only assigned the addresses of objects in data memory or is only assigned the addresses of objects in program memory, the integer address is copied without modification into the pointer variable. If a pointer variable throughout the entire program is assigned addresses of objects in data memory and also addresses of objects in program memory, then the MSb of the integer will be set if it is cast to a pointer to `const` type; otherwise the MSb is not set. The remaining bits of the integer are assigned to the pointer variable without modification.

When casting a pointer to an integer, the value held by the pointer is assigned to the integer without modification. The usual integer truncation applies if the integer is larger than the size of the pointer.

### D.8.3 The type of integer required to hold the difference between two `s` to members of the same array, `ptrdiff_t` (6.3.6, 7.1.1)

The type of `ptrdiff_t` is `unsigned int`.

## D.9 REGISTERS (G.3.8)

### D.9.1 The extent to which objects can actually be placed in registers by use of the register storage-class specifier (6.5.1)

This specifier has no effect.



## D.10 STRUCTURES, UNIONS, ENUMERATIONS, AND BIT-FIELDS (G.3.9)

### D.10.1 A member of a union object is accessed using a member of a different type (6.3.2.3)

The value stored in the union member is accessed and interpreted according to the type of the member by which it is accessed.

### D.10.2 The padding and alignment of members of structures (6.5.2.1)

No padding or alignment is imposed on structure members.

### D.10.3 Whether a plain int bit-field is treated as a signed int bit-field or as an unsigned int bit-field (6.5.2.1)

It is treated as an `unsigned int`. Signed bit-fields are not supported.

### D.10.4 The order of allocation of bit-fields within an int (6.5.2.1)

The first bit-field defined in a structure is allocated the LSb position in the storage unit. Subsequent bit-fields are allocated higher-order bits.

### D.10.5 Whether a bit-field can straddle a storage-unit boundary (6.5.2.1)

A bit-field cannot straddle a storage unit. Any bit-field that would straddle a storage unit will be allocated to the LSb position in a new storage unit.

### D.10.6 The integer type chosen to represent the values of an enumeration type (6.5.2.2)

The type chosen to represent an enumerated type depends on the enumerated values. A signed type is chosen if any value is negative; unsigned otherwise. If a `char` type is sufficient to hold the range of values, then this type is chosen; otherwise, an `int` type is chosen. Enumerated values must fit within an `int` type and will be truncated if this is not the case.

## D.11 QUALIFIERS (G.3.10)

### D.11.1 What constitutes an access to an object that has volatile-qualified type (6.5.5.3)

Each reference to the name of a `volatile`-qualified object constitutes one access to the object.

## D.12 DECLARATORS (G.3.11)

### D.12.1 The maximum number of declarators that can modify an arithmetic, structure, or union type (6.5.4)

No limit is imposed by the compiler.

## D.13 STATEMENTS (G.3.12)

### D.13.1 The maximum number of case values in a switch statement (6.6.4.2)

There is no practical limit to the number of `case` values inside a `switch` statement.

## D.14 PREPROCESSING DIRECTIVES (G.3.13)

### D.14.1 Whether the value of a single-character character constant in a constant expression that controls conditional inclusion matches the value of the same character constant in the execution character set (6.8.1)

The character constant evaluates to the same value in both environments.

### D.14.2 Whether such a character constant can have a negative value (6.8.1)

It cannot be negative.

### D.14.3 The method for locating includable source files (6.8.2)

For files specified in angle brackets, < >, the search first takes place in the directories specified by `-I` options, then in the standard compiler directory (this is the directory `include` found in the compiler install location).

For files specified in quotes, " ", the compiler searches the current working directory first, then directories specified by `-I` options, then in the standard compiler directory.

If the first character of the filename is a `/`, then it is assumed that a full or relative path to the file is specified. On Windows compilers, a path is also specified by either `\` or a DOS drive letter followed by a colon, e.g., `C:`, appearing first in the filename.

### D.14.4 The support of quoted names for includable source files (6.8.2)

Quoted names are supported.

### D.14.5 The mapping of source file character sequences (6.8.2)

Source file characters are mapped to their corresponding ASCII values.

### D.14.6 The behavior on each recognized `#pragma` directive (6.8.6)

See [Section 5.14.4 "Pragma Directives"](#).

### D.14.7 The definitions for `__DATE__` and `__TIME__` when, respectively, the date and time of translation are not available (6.8.8)

These macros are always available from the environment.

## D.15 LIBRARY FUNCTIONS (G.3.14)

### D.15.1 The null constant to which the macro NULL expands (7.1.6)

The macro `NULL` expands to `0`.

### D.15.2 The diagnostic printed by, and the termination behavior of, the `assert` function (7.2)

The function prints to `stderr` `"Assertion failed: %s line %d: \"%s\"\\n"` where the placeholders are replaced with the filename, line number, and message string, respectively. The function does not return. The program will terminate or become caught in an endless loop, dependent on the selected device.

### D.15.3 The sets of characters tested for by the `isalnum`, `isalpha`, `iscntrl`, `islower`, `isprint`, and `isupper` functions (7.3.1)

`isalnum`: ASCII characters a-z, A-Z, 0-9

`isalpha`: ASCII characters a-z, A-Z

`iscntrl`: ASCII values less than 32

`islower`: ASCII characters a-z

`isprint`: ASCII values between 32 and 126, inclusive

`isupper`: ASCII characters A-Z

### D.15.4 The values returned by the mathematics functions on domain errors (7.5.1)

`acos(x)`  $|x| > 1.0$   $\pi/2$

`asin(x)`  $|x| > 1.0$  `0.0`

`atan2(x, y)`  $x=0, y=0$  `0.0`

`log(x)`  $x < 0$  `0.0`

`pow(0, 0)` `0.0`

`pow(0, y)`  $y < 0$  `0.0`

`pow(x, y)`  $x < 0$   $y$  is non-integral `0.0`

`sqrt(x)`  $x < 0$  `0.0`

`fmod(x, 0)`  $x$

### D.15.5 Whether the mathematics functions set the integer expression `errno` to the value of the macro `ERANGE` on underflow range errors (7.5.1)

The `exp()`, `frexp()` and `log()` functions set `errno` to `ERANGE` on underflow.

### D.15.6 Whether a domain error occurs, or a zero is returned, when the `fmod` function has a second argument of zero (7.5.6.4)

It returns the first argument and no domain error is produced.

### D.15.7 The set of signals for the signal function (7.7.1.1)

The `signal()` function is not implemented

## D.15.8 The output for %p conversion in the fprintf function (7.9.6.1)

The address is printed as an `unsigned long`.

## D.15.9 The local time zone and Daylight Saving Time (7.12.1)

Default time zone is GMT. Can be specified by setting the variable `time_zone`. Daylight saving is not implemented.

---

---

## Glossary

---

---

### A

#### **Absolute Section**

A GCC compiler section with a fixed (absolute) address that cannot be changed by the linker.

#### **Absolute Variable/Function**

A variable or function placed at an absolute address using the OCG compiler's @ *address* syntax.

#### **Access Memory**

PIC18 Only – Special registers on PIC18 devices that allow access regardless of the setting of the Bank Select Register (BSR).

#### **Access Entry Points**

Access entry points provide a way to transfer control across segments to a function which cannot be defined at link time. They support the separate linking of boot and secure application segments.

#### **Address**

Value that identifies a location in memory.

#### **Alphabetic Character**

Alphabetic characters are those characters that are letters of the Arabic alphabet (a, b, ..., z, A, B, ..., Z).

#### **Alphanumeric**

Alphanumeric characters are comprised of alphabetic characters and decimal digits (0,1, ..., 9).

#### **ANDed Breakpoints**

Set up an ANDed condition for breaking, i.e., breakpoint 1 AND breakpoint 2 must occur at the same time before a program halt. This can only be accomplished if a data breakpoint and a program memory breakpoint occur at the same time.

#### **Anonymous Structure**

16-bit C Compiler – An unnamed structure.

PIC18 C Compiler – An unnamed structure that is a member of a C union. The members of an anonymous structure can be accessed as if they were members of the enclosing union. For example, in the following code, `hi` and `lo` are members of an anonymous structure inside the union `caster`.

```
union castaway {
    int intval;
    struct {
        char lo; //accessible as caster.lo
        char hi; //accessible as caster.hi
    };
} caster;
```

## **ANSI**

American National Standards Institute is an organization responsible for formulating and approving standards in the United States.

## **Application**

A set of software and hardware that can be controlled by a PIC microcontroller.

## **Archive/Archiver**

An archive/library is a collection of relocatable object modules. It is created by assembling multiple source files to object files, and then using the archiver/librarian to combine the object files into one archive/library file. An archive/library can be linked with object modules and other archives/libraries to create executable code.

## **ASCII**

American Standard Code for Information Interchange is a character set encoding that uses 7 binary digits to represent each character. It includes upper and lower case letters, digits, symbols and control characters.

## **Assembly/Assembler**

Assembly is a programming language that describes binary machine code in a symbolic form. An assembler is a language tool that translates assembly language source code into machine code.

## **Assigned Section**

A GCC compiler section which has been assigned to a target memory block in the linker command file.

## **Asynchronously**

Multiple events that do not occur at the same time. This is generally used to refer to interrupts that can occur at any time during processor execution.

## **Asynchronous Stimulus**

Data generated to simulate external inputs to a simulator device.

## **Attribute**

GCC characteristics of variables or functions in a C program which are used to describe machine-specific properties.

## **Attribute, Section**

GCC characteristics of sections, such as “executable”, “readonly”, or “data” that can be specified as flags in the assembler `.section` directive.

## **B**

### **Binary**

The base two numbering system that uses the digits 0-1. The rightmost digit counts ones, the next counts multiples of 2, then  $2^2 = 4$ , etc.

### **Breakpoint**

Hardware Breakpoint: An event whose execution will cause a halt.

Software Breakpoint: An address where execution of the firmware will halt. Usually achieved by a special break instruction.

### **Build**

Compile and link all the source files for an application.

## C

### **C/C++**

C is a general-purpose programming language which features economy of expression, modern control flow and data structures, and a rich set of operators. C++ is the object-oriented version of C.

### **Calibration Memory**

A special function register or registers used to hold values for calibration of a PIC microcontroller on-board RC oscillator or other device peripherals.

### **Central Processing Unit**

The part of a device that is responsible for fetching the correct instruction for execution, decoding that instruction, and then executing that instruction. When necessary, it works in conjunction with the arithmetic logic unit (ALU) to complete the execution of the instruction. It controls the program memory address bus, the data memory address bus, and accesses to the stack.

### **Clean**

Clean removes all intermediary project files, such as object, hex and debug files, for the active project. These files are recreated from other files when a project is built.

### **COFF**

Common Object File Format. An object file of this format contains machine code, debugging and other information.

### **Command Line Interface**

A means of communication between a program and its user based solely on textual input and output.

### **Compiled Stack**

A region of memory managed by the compiler in which variables are statically allocated space. It replaces a software or hardware stack when such mechanisms cannot be efficiently implemented on the target device.

### **Compiler**

A program that translates a source file written in a high-level language into machine code.

### **Conditional Assembly**

Assembly language code that is included or omitted based on the assembly-time value of a specified expression.

### **Conditional Compilation**

The act of compiling a program fragment only if a certain constant expression, specified by a preprocessor directive, is true.

### **Configuration Bits**

Special-purpose bits programmed to set PIC microcontroller modes of operation. A Configuration bit can or cannot be preprogrammed.

### **Control Directives**

Directives in assembly language code that cause code to be included or omitted based on the assembly-time value of a specified expression.

### **CPU**

See Central Processing Unit.

## Cross Reference File

A file that references a table of symbols and a list of files that references the symbol. If the symbol is defined, the first file listed is the location of the definition. The remaining files contain references to the symbol.

## D

### Data Directives

Data directives are those that control the assembler's allocation of program or data memory and provide a way to refer to data items symbolically; that is, by meaningful names.

### Data Memory

On Microchip MCU and DSC devices, data memory (RAM) is comprised of General Purpose Registers (GPRs) and Special Function Registers (SFRs). Some devices also have EEPROM data memory.

### Data Monitor and Control Interface (DMCI)

The Data Monitor and Control Interface, or DMCI, is a tool in MPLAB X IDE. The interface provides dynamic input control of application variables in projects. Application-generated data can be viewed graphically using any of 4 dynamically-assignable graph windows.

### Debug/Debugger

See ICE/ICD.

### Debugging Information

Compiler and assembler options that, when selected, provide varying degrees of information used to debug application code. See compiler or assembler documentation for details on selecting debug options.

### Deprecated Features

Features that are still supported for legacy reasons, but will eventually be phased out and no longer used.

### Device Programmer

A tool used to program electrically programmable semiconductor devices such as microcontrollers.

### Digital Signal Controller

A digital signal controller (DSC) is a microcontroller device with digital signal processing capability, i.e., Microchip dsPIC DSC devices.

### Digital Signal Processing\Digital Signal Processor

Digital signal processing (DSP) is the computer manipulation of digital signals, commonly analog signals (sound or image) which have been converted to digital form (sampled). A digital signal processor is a microprocessor that is designed for use in digital signal processing.

### Directives

Statements in source code that provide control of the language tool's operation.

### Download

Download is the process of sending data from a host to another device, such as an emulator, programmer or target board.

### DWARF

Debug With Arbitrary Record Format. DWARF is a debug information format for ELF files.



## E

### EEPROM

Electrically Erasable Programmable Read Only Memory. A special type of PROM that can be erased electrically. Data is written or erased one byte at a time. EEPROM retains its contents even when power is turned off.

### ELF

Executable and Linking Format. An object file of this format contains machine code. Debugging and other information is specified in with DWARF. ELF/DWARF provide better debugging of optimized code than COFF.

### Emulation/Emulator

See ICE/ICD.

### Endianness

The ordering of bytes in a multi-byte object.

### Environment

MPLAB PM3 – A folder containing files on how to program a device. This folder can be transferred to a SD/MMC card.

### Epilogue

A portion of compiler-generated code that is responsible for deallocating stack space, restoring registers and performing any other machine-specific requirement specified in the runtime model. This code executes after any user code for a given function, immediately prior to the function return.

### EPROM

Erasable Programmable Read Only Memory. A programmable read-only memory that can be erased usually by exposure to ultraviolet radiation.

### Error/Error File

An error reports a problem that makes it impossible to continue processing your program. When possible, an error identifies the source file name and line number where the problem is apparent. An error file contains error messages and diagnostics generated by a language tool.

### Event

A description of a bus cycle which can include address, data, pass count, external input, cycle type (fetch, R/W), and time stamp. Events are used to describe triggers, breakpoints and interrupts.

### Executable Code

Software that is ready to be loaded for execution.

### Export

Send data out of the MPLAB IDE in a standardized format.

### Expressions

Combinations of constants and/or symbols separated by arithmetic or logical operators.

### Extended Microcontroller Mode

In extended microcontroller mode, on-chip program memory as well as external memory is available. Execution automatically switches to external if the program memory address is greater than the internal memory space of the PIC18 device.

## **Extended Mode (PIC18 MCUs)**

In Extended mode, the compiler will utilize the extended instructions (i.e., `ADDFSR`, `ADDULNK`, `CALLW`, `MOVSF`, `MOVSS`, `PUSHL`, `SUBFSR` and `SUBULNK`) and the indexed with literal offset addressing.

## **External Label**

A label that has external linkage.

## **External Linkage**

A function or variable has external linkage if it can be referenced from outside the module in which it is defined.

## **External Symbol**

A symbol for an identifier which has external linkage. This can be a reference or a definition.

## **External Symbol Resolution**

A process performed by the linker in which external symbol definitions from all input modules are collected in an attempt to resolve all external symbol references. Any external symbol references which do not have a corresponding definition cause a linker error to be reported.

## **External Input Line**

An external input signal logic probe line (`TRIGIN`) for setting an event based upon external signals.

## **External RAM**

Off-chip Read/Write memory.

## **F**

### **Fatal Error**

An error that will halt compilation immediately. No further messages will be produced.

### **File Registers**

On-chip data memory, including General Purpose Registers (GPRs) and Special Function Registers (SFRs).

### **Filter**

Determine by selection what data is included/excluded in a trace display or data file.

### **Fixup**

The process of replacing object file symbolic references with absolute addresses after relocation by the linker.

### **Flash**

A type of EEPROM where data is written or erased in blocks instead of bytes.

### **FNOP**

Forced No Operation. A forced NOP cycle is the second cycle of a two-cycle instruction. Because the PIC microcontroller architecture is pipelined, it prefetches the next instruction in the physical address space while it is executing the current instruction. However, if the current instruction changes the program counter, this prefetched instruction is explicitly ignored, causing a forced NOP cycle.

### **Frame Pointer**

A pointer that references the location on the stack that separates the stack-based arguments from the stack-based local variables. Provides a convenient base from which to access local variables and other values for the current function.

## **Free-Standing**

An implementation that accepts any strictly conforming program that does not use complex types and in which the use of the features specified in the library clause (ANSI '89 standard clause 7) is confined to the contents of the standard headers `<float.h>`, `<iso646.h>`, `<limits.h>`, `<stdarg.h>`, `<stdbool.h>`, `<stddef.h>` and `<stdint.h>`.

## **G**

### **GPR**

General Purpose Register. The portion of device data memory (RAM) available for general use.

## **H**

### **Halt**

A stop of program execution. Executing Halt is the same as stopping at a breakpoint.

### **Heap**

An area of memory used for dynamic memory allocation where blocks of memory are allocated and freed in an arbitrary order determined at runtime.

### **Hex Code\Hex File**

Hex code is executable instructions stored in a hexadecimal format code. Hex code is contained in a hex file.

### **Hexadecimal**

The base 16 numbering system that uses the digits 0-9 plus the letters A-F (or a-f). The digits A-F represent hexadecimal digits with values of (decimal) 10 to 15. The rightmost digit counts ones, the next counts multiples of 16, then  $16^2 = 256$ , etc.

### **High Level Language**

A language for writing programs that is further removed from the processor than assembly.

## **I**

### **ICE/ICD**

In-Circuit Emulator/In-Circuit Debugger: A hardware tool that debugs and programs a target device. An emulator has more features than a debugger, such as trace.

In-Circuit Emulation/In-Circuit Debug: The act of emulating or debugging with an in-circuit emulator or debugger.

-ICE/-ICD: A device (MCU or DSC) with on-board in-circuit emulation or debug circuitry. This device is always mounted on a header board and used to debug with an in-circuit emulator or debugger.

### **ICSP**

In-Circuit Serial Programming. A method of programming Microchip embedded devices using serial communication and a minimum number of device pins.

### **IDE**

Integrated Development Environment, as in MPLAB IDE.

### **Identifier**

A function or variable name.

### **IEEE**

Institute of Electrical and Electronics Engineers.

## **Import**

Bring data into the MPLAB IDE from an outside source, such as from a hex file.

## **Initialized Data**

Data which is defined with an initial value. In C,

```
int myVar=5;
```

defines a variable which will reside in an initialized data section.

## **Instruction Set**

The collection of machine language instructions that a particular processor understands.

## **Instructions**

A sequence of bits that tells a central processing unit to perform a particular operation and can contain data to be used in the operation.

## **Internal Linkage**

A function or variable has internal linkage if it cannot be accessed from outside the module in which it is defined.

## **International Organization for Standardization**

An organization that sets standards in many businesses and technologies, including computing and communications. Also known as ISO.

## **Interrupt**

A signal to the CPU that suspends the execution of a running application and transfers control to an Interrupt Service Routine (ISR) so that the event can be processed. Upon completion of the ISR, normal execution of the application resumes.

## **Interrupt Handler**

A routine that processes special code when an interrupt occurs.

## **Interrupt Service Request (IRQ)**

An event which causes the processor to temporarily suspend normal instruction execution and to start executing an interrupt handler routine. Some processors have several interrupt request events allowing different priority interrupts.

## **Interrupt Service Routine (ISR)**

Language tools – A function that handles an interrupt.

MPLAB IDE – User-generated code that is entered when an interrupt occurs. The location of the code in program memory will usually depend on the type of interrupt that has occurred.

## **Interrupt Vector**

Address of an interrupt service routine or interrupt handler.

## **L**

### **L-value**

An expression that refers to an object that can be examined and/or modified. An l-value expression is used on the left-hand side of an assignment.

### **Latency**

The time between an event and its response.

### **Library/Librarian**

See Archive/Archiver.

## **Linker**

A language tool that combines object files and libraries to create executable code, resolving references from one module to another.

## **Linker Script Files**

Linker script files are the command files of a linker. They define linker options and describe available memory on the target platform.

## **Listing Directives**

Listing directives are those directives that control the assembler listing file format. They allow the specification of titles, pagination and other listing control.

## **Listing File**

A listing file is an ASCII text file that shows the machine code generated for each C source statement, assembly instruction, assembler directive, or macro encountered in a source file.

## **Little Endian**

A data ordering scheme for multibyte data whereby the LSB is stored at the lower addresses.

## **Local Label**

A local label is one that is defined inside a macro with the LOCAL directive. These labels are particular to a given instance of a macro's instantiation. In other words, the symbols and labels that are declared as local are no longer accessible after the ENDM macro is encountered.

## **Logic Probes**

Up to 14 logic probes can be connected to some Microchip emulators. The logic probes provide external trace inputs, trigger output signal, +5V, and a common ground.

## **Loop-Back Test Board**

Used to test the functionality of the MPLAB REAL ICE in-circuit emulator.

## **LVDS**

Low Voltage Differential Signaling. A low noise, low-power, low amplitude method for high-speed (gigabits per second) data transmission over copper wire.

With standard I/O signaling, data storage is contingent upon the actual voltage level. Voltage level can be affected by wire length (longer wires increase resistance, which lowers voltage). But with LVDS, data storage is distinguished only by positive and negative voltage values, not the voltage level. Therefore, data can travel over greater lengths of wire while maintaining a clear and consistent data stream.

Source: <http://www.webopedia.com/TERM/L/LVDS.html>.

## **M**

### **Machine Code**

The representation of a computer program that is actually read and interpreted by the processor. A program in binary machine code consists of a sequence of machine instructions (possibly interspersed with data). The collection of all possible instructions for a particular processor is known as its "instruction set".

### **Machine Language**

A set of instructions for a specific central processing unit, designed to be usable by a processor without being translated.

## **Macro**

Macro instruction. An instruction that represents a sequence of instructions in abbreviated form.

## **Macro Directives**

Directives that control the execution and data allocation within macro body definitions.

## **Makefile**

Export to a file the instructions to Make the project. Use this file to Make your project outside of MPLAB IDE, i.e., with a `make`.

## **Make Project**

A command that rebuilds an application, recompiling only those source files that have changed since the last complete compilation.

## **MCU**

Microcontroller Unit. An abbreviation for microcontroller. Also `uC`.

## **Memory Model**

For C compilers, a representation of the memory available to the application. For the PIC18 C compiler, a description that specifies the size of pointers that point to program memory.

## **Message**

Text displayed to alert you to potential problems in language tool operation. A message will not stop operation.

## **Microcontroller**

A highly integrated chip that contains a CPU, RAM, program memory, I/O ports and timers.

## **Microcontroller Mode**

One of the possible program memory configurations of PIC18 microcontrollers. In microcontroller mode, only internal execution is allowed. Thus, only the on-chip program memory is available in microcontroller mode.

## **Microprocessor Mode**

One of the possible program memory configurations of PIC18 microcontrollers. In microprocessor mode, the on-chip program memory is not used. The entire program memory is mapped externally.

## **Mnemonics**

Text instructions that can be translated directly into machine code. Also referred to as opcodes.

## **Module**

The preprocessed output of a source file after preprocessor directives have been executed. Also known as a translation unit.

## **MPASM™ Assembler**

Microchip Technology's relocatable macro assembler for PIC microcontroller devices, KeeLoq® devices and Microchip memory devices.

## **MPLAB Language Tool for Device**

Microchip's C compilers, assemblers and linkers for specified devices. Select the type of language tool based on the device you will be using for your application, e.g., if you will be creating C code on a PIC18 MCU, select the MPLAB C Compiler for PIC18 MCUs.

**MPLAB ICD**

Microchip's in-circuit debuggers that works with MPLAB IDE. See ICE/ICD.

**MPLAB IDE**

Microchip's Integrated Development Environment. MPLAB IDE comes with an editor, project manager and simulator.

**MPLAB PM3**

A device programmer from Microchip. Programs PIC18 microcontrollers and dsPIC digital signal controllers. Can be used with MPLAB IDE or stand-alone. Replaces PRO MATE II.

**MPLAB REAL ICE™ In-Circuit Emulator**

Microchip's next-generation in-circuit emulators that works with MPLAB IDE. See ICE/ICD.

**MPLAB SIM**

Microchip's simulator that works with MPLAB IDE in support of PIC MCU and dsPIC DSC devices.

**MPLIB™ Object Librarian**

Microchip's librarian that can work with MPLAB IDE. MPLIB librarian is an object librarian for use with COFF object modules created using either MPASM assembler (mpasm or mpasmwin v2.0) or MPLAB C18 C compiler.

**MPLINK™ Object Linker**

MPLINK linker is an object linker for the Microchip MPASM assembler and the Microchip C18 C compiler. MPLINK linker also can be used with the Microchip MPLIB librarian. MPLINK linker is designed to be used with MPLAB IDE, though it does not have to be.

**MRU**

Most Recently Used. Refers to files and windows available to be selected from MPLAB IDE main pull down menus.

**N****Native Data Size**

For Native trace, the size of the variable used in a Watch window must be of the same size as the selected device's data memory: bytes for PIC18 devices and words for 16-bit devices.

**Nesting Depth**

The maximum level to which macros can include other macros.

**Node**

MPLAB IDE project component.

**Non-Extended Mode (PIC18 MCUs)**

In Non-Extended mode, the compiler will not utilize the extended instructions nor the indexed with literal offset addressing.

**Non Real Time**

Refers to the processor at a breakpoint or executing single-step instructions or MPLAB IDE being run in simulator mode.

**Non-Volatile Storage**

A storage device whose contents are preserved when its power is off.

## **NOP**

No Operation. An instruction that has no effect when executed except to advance the program counter.

## **O**

### **Object Code/Object File**

Object code is the machine code generated by an assembler or compiler. An object file is a file containing machine code and, possibly, debug information. It can be immediately executable or it can be relocatable, requiring linking with other object files, e.g., libraries, to produce a complete executable program.

### **Object File Directives**

Directives that are used only when creating an object file.

## **Octal**

The base 8 number system that only uses the digits 0-7. The rightmost digit counts ones, the next digit counts multiples of 8, then  $8^2 = 64$ , etc.

## **Off-Chip Memory**

Off-chip memory refers to the memory selection option for the PIC18 device where memory can reside on the target board, or where all program memory can be supplied by the emulator. The **Memory** tab accessed from *Options>Development Mode* provides the Off-Chip Memory selection dialog box.

## **Opcodes**

Operational Codes. See Mnemonics.

## **Operators**

Symbols, like the plus sign '+' and the minus sign '-', that are used when forming well-defined expressions. Each operator has an assigned precedence that is used to determine order of evaluation.

## **OTP**

One Time Programmable. EPROM devices that are not in windowed packages. Since EPROM needs ultraviolet light to erase its memory, only windowed devices are erasable.

## **P**

### **Pass Counter**

A counter that decrements each time an event (such as the execution of an instruction at a particular address) occurs. When the pass count value reaches zero, the event is satisfied. You can assign the Pass Counter to break and trace logic, and to any sequential event in the complex trigger dialog.

## **PC**

Personal Computer or Program Counter.

### **PC Host**

Any PC running a supported Windows operating system.

### **Persistent Data**

Data that is never cleared or initialized. Its intended use is so that an application can preserve data across a device Reset.

### **Phantom Byte**

An unimplemented byte in the dsPIC architecture that is used when treating the 24-bit instruction word as if it were a 32-bit instruction word. Phantom bytes appear in dsPIC hex files.



## **PIC MCUs**

PIC microcontrollers (MCUs) refers to all Microchip microcontroller families.

## **PICKit 2 and 3**

Microchip's developmental device programmers with debug capability through Debug Express. See the Readme files for each tool to see which devices are supported.

## **Plug-ins**

The MPLAB IDE has both built-in components and plug-in modules to configure the system for a variety of software and hardware tools. Several plug-in tools can be found under the Tools menu.

## **Pod**

The enclosure for an in-circuit emulator or debugger. Other names are "Puck", if the enclosure is round, and "Probe", not be confused with logic probes.

## **Power-on-Reset Emulation**

A software randomization process that writes random values in data RAM areas to simulate uninitialized values in RAM upon initial power application.

## **Pragma**

A directive that has meaning to a specific compiler. Often a pragma is used to convey implementation-defined information to the compiler. MPLAB C30 uses attributes to convey this information.

## **Precedence**

Rules that define the order of evaluation in expressions.

## **Production Programmer**

A production programmer is a programming tool that has resources designed in to program devices rapidly. It has the capability to program at various voltage levels and completely adheres to the programming specification. Programming a device as fast as possible is of prime importance in a production environment where time is of the essence as the application circuit moves through the assembly line.

## **Profile**

For MPLAB SIM simulator, a summary listing of executed stimulus by register.

## **Program Counter**

The location that contains the address of the instruction that is currently executing.

## **Program Counter Unit**

16-bit assembler – A conceptual representation of the layout of program memory. The program counter increments by 2 for each instruction word. In an executable section, 2 program counter units are equivalent to 3 bytes. In a read-only section, 2 program counter units are equivalent to 2 bytes.

## **Program Memory**

MPLAB IDE – The memory area in a device where instructions are stored. Also, the memory in the emulator or simulator containing the downloaded target application firmware.

16-bit assembler/compiler – The memory area in a device where instructions are stored.

## **Project**

A project contains the files needed to build an application (source code, linker script files, etc.) along with their associations to various build tools and build options.

## **Prologue**

A portion of compiler-generated code that is responsible for allocating stack space, preserving registers and performing any other machine-specific requirement specified in the runtime model. This code executes before any user code for a given function.

## **Prototype System**

A term referring to a user's target application, or target board.

## **Psect**

The OCG equivalent of a GCC section, short for program section. A block of code or data which is treated as a whole by the linker.

## **PWM Signals**

Pulse Width Modulation Signals. Certain PIC MCU devices have a PWM peripheral.

## **Q**

### **Qualifier**

An address or an address range used by the Pass Counter or as an event before another operation in a complex trigger.

## **R**

### **Radix**

The number base, hex, or decimal, used in specifying an address.

### **RAM**

Random Access Memory (Data Memory). Memory in which information can be accessed in any order.

### **Raw Data**

The binary representation of code or data associated with a section.

### **Read Only Memory**

Memory hardware that allows fast access to permanently stored data but prevents addition to or modification of the data.

### **Real Time**

When an in-circuit emulator or debugger is released from the halt state, the processor runs in Real Time mode and behaves exactly as the normal chip would behave. In Real Time mode, the real time trace buffer of an emulator is enabled and constantly captures all selected cycles, and all break logic is enabled. In an in-circuit emulator or debugger, the processor executes in real time until a valid breakpoint causes a halt, or until the user halts the execution.

In the simulator, real time simply means execution of the microcontroller instructions as fast as they can be simulated by the host CPU.

### **Recursive Calls**

A function that calls itself, either directly or indirectly.

### **Recursion**

The concept that a function or macro, having been defined, can call itself. Great care should be taken when writing recursive macros; it is easy to get caught in an infinite loop where there will be no exit from the recursion.

### **Reentrant**

A function that can have multiple, simultaneously active instances. This can happen due to either direct or indirect recursion or through execution during interrupt processing.

## **Relaxation**

The process of converting an instruction to an identical, but smaller instruction. This is useful for saving on code size. MPLAB ASM30 currently knows how to RELAX a CALL instruction into an RCALL instruction. This is done when the symbol that is being called is within +/- 32k instruction words from the current instruction.

## **Relocatable**

An object whose address has not been assigned to a fixed location in memory.

## **Relocatable Section**

16-bit assembler – A section whose address is not fixed (absolute). The linker assigns addresses to relocatable sections through a process called relocation.

## **Relocation**

A process performed by the linker in which absolute addresses are assigned to relocatable sections and all symbols in the relocatable sections are updated to their new addresses.

## **ROM**

Read Only Memory (Program Memory). Memory that cannot be modified.

## **Run**

The command that releases the emulator from halt, allowing it to run the application code and change or respond to I/O in real time.

## **Run-time Model**

Describes the use of target architecture resources.

## **Runtime Watch**

A Watch window where the variables change in as the application is run. See individual tool documentation to determine how to set up a runtime watch. Not all tools support runtime watches.

## **S**

### **Scenario**

For MPLAB SIM simulator, a particular setup for stimulus control.

### **Section**

The GCC equivalent of an OCG psect. A block of code or data which is treated as a whole by the linker.

### **Section Attribute**

A GCC characteristic ascribed to a section (e.g., an `access` section).

### **Sequenced Breakpoints**

Breakpoints that occur in a sequence. Sequence execution of breakpoints is bottom-up; the last breakpoint in the sequence occurs first.

### **Serialized Quick Turn Programming**

Serialization allows you to program a serial number into each microcontroller device that the Device Programmer programs. This number can be used as an entry code, password or ID number.

### **Shell**

The MPASM assembler shell is a prompted input interface to the macro assembler. There are two MPASM assembler shells: one for the DOS version and one for the Windows version.

## **Simulator**

A software program that models the operation of devices.

## **Single Step**

This command steps through code, one instruction at a time. After each instruction, MPLAB IDE updates register windows, watch variables, and status displays so you can analyze and debug instruction execution. You can also single step C compiler source code, but instead of executing single instructions, MPLAB IDE will execute all assembly level instructions generated by the line of the high level C statement.

## **Skew**

The information associated with the execution of an instruction appears on the processor bus at different times. For example, the executed opcodes appears on the bus as a fetch during the execution of the previous instruction, the source data address and value and the destination data address appear when the opcodes is actually executed, and the destination data value appears when the next instruction is executed. The trace buffer captures the information that is on the bus at one instance. Therefore, one trace buffer entry will contain execution information for three instructions. The number of captured cycles from one piece of information to another for a single instruction execution is referred to as the skew.

## **Skid**

When a hardware breakpoint is used to halt the processor, one or more additional instructions can be executed before the processor halts. The number of extra instructions executed after the intended breakpoint is referred to as the skid.

## **Source Code**

The form in which a computer program is written by the programmer. Source code is written in a formal programming language which can be translated into machine code or executed by an interpreter.

## **Source File**

An ASCII text file containing source code.

## **Special Function Registers (SFRs)**

The portion of data memory (RAM) dedicated to registers that control I/O processor functions, I/O status, timers or other modes or peripherals.

## **SQTP**

See Serialized Quick Turn Programming.

## **Stack, Hardware**

Locations in PIC microcontroller where the return address is stored when a function call is made.

## **Stack, Software**

Memory used by an application for storing return addresses, function parameters, and local variables. This memory is dynamically allocated at runtime by instructions in the program. It allows for reentrant function calls.

## **Stack, Compiled**

A region of memory managed and allocated by the compiler in which variables are statically assigned space. It replaces a software stack when such mechanisms cannot be efficiently implemented on the target device. It precludes reentrancy.

## **MPLAB Starter Kit for *Device***

Microchip's starter kits contains everything needed to begin exploring the specified device. View a working application and then debug and program you own changes.

## **Static RAM or SRAM**

Static Random Access Memory. Program memory you can read/write on the target board that does not need refreshing frequently.

## **Status Bar**

The Status Bar is located on the bottom of the MPLAB IDE window and indicates such current information as cursor position, development mode and device, and active tool bar.

## **Step Into**

This command is the same as Single Step. Step Into (as opposed to Step Over) follows a CALL instruction into a subroutine.

## **Step Over**

Step Over allows you to debug code without stepping into subroutines. When stepping over a CALL instruction, the next breakpoint will be set at the instruction after the CALL. If for some reason the subroutine gets into an endless loop or does not return properly, the next breakpoint will never be reached. The Step Over command is the same as Single Step except for its handling of CALL instructions.

## **Step Out**

Step Out allows you to step out of a subroutine which you are currently stepping through. This command executes the rest of the code in the subroutine and then stops execution at the return address to the subroutine.

## **Stimulus**

Input to the simulator, i.e., data generated to exercise the response of simulation to external signals. Often the data is put into the form of a list of actions in a text file. Stimulus can be asynchronous, synchronous (pin), clocked and register.

## **Stopwatch**

A counter for measuring execution cycles.

## **Storage Class**

Determines the lifetime of the memory associated with the identified object.

## **Storage Qualifier**

Indicates special properties of the objects being declared (e.g., `const`).

## **Symbol**

A symbol is a general purpose mechanism for describing the various pieces which comprise a program. These pieces include function names, variable names, section names, file names, struct/enum/union tag names, etc. Symbols in MPLAB IDE refer mainly to variable names, function names and assembly labels. The value of a symbol after linking is its value in memory.

## **Symbol, Absolute**

Represents an immediate value such as a definition through the assembly `.equ` directive.

## **System Window Control**

The system window control is located in the upper left corner of windows and some dialogs. Clicking on this control usually pops up a menu that has the items "Minimize," "Maximize," and "Close."

## **T**

### **Target**

Refers to user hardware.

## **Target Application**

Software residing on the target board.

## **Target Board**

The circuitry and programmable device that makes up the target application.

## **Target Processor**

The microcontroller device on the target application board.

## **Template**

Lines of text that you build for inserting into your files at a later time. The MPLAB Editor stores templates in template files.

## **Tool Bar**

A row or column of icons that you can click on to execute MPLAB IDE functions.

## **Trace**

An emulator or simulator function that logs program execution. The emulator logs program execution into its trace buffer which is uploaded to MPLAB IDE's trace window.

## **Trace Memory**

Trace memory contained within the emulator. Trace memory is sometimes called the trace buffer.

## **Trace Macro**

A macro that will provide trace information from emulator data. Since this is a software trace, the macro must be added to code, the code must be recompiled or reassembled, and the target device must be programmed with this code before trace will work.

## **Trigger Output**

Trigger output refers to an emulator output signal that can be generated at any address or address range, and is independent of the trace and breakpoint settings. Any number of trigger output points can be set.

## **Trigraphs**

Three-character sequences, all starting with ??, that are defined by ISO C as replacements for single characters.

## **U**

### **Unassigned Section**

A section which has not been assigned to a specific target memory block in the linker command file. The linker must find a target memory block in which to allocate an unassigned section.

### **Uninitialized Data**

Data which is defined without an initial value. In C,

```
int myVar;
```

defines a variable which will reside in an uninitialized data section.

### **Upload**

The Upload function transfers data from a tool, such as an emulator or programmer, to the host PC or from the target board to the emulator.

### **USB**

Universal Serial Bus. An external peripheral interface standard for communication between a computer and external peripherals over a cable using bi-serial transmission. USB 1.0/1.1 supports data transfer rates of 12 Mbps. Also referred to as high-speed USB, USB 2.0 supports data rates up to 480 Mbps.

## V

### Vector

The memory locations that an application will jump to when either a Reset or interrupt occurs.

### Volatile

A variable qualifier which prevents the compiler applying optimizations that affect how the variable is accessed in memory.

## W

### Warning

MPLAB IDE – An alert that is provided to warn you of a situation that would cause physical damage to a device, software file, or equipment.

16-bit assembler/compiler – Warnings report conditions that can indicate a problem, but do not halt processing. In MPLAB C30, warning messages report the source file name and line number, but include the text 'warning:' to distinguish them from error messages.

### Watch Variable

A variable that you can monitor during a debugging session in a Watch window.

### Watch Window

Watch windows contain a list of watch variables that are updated at each breakpoint.

### Watchdog Timer (WDT)

A timer on a PIC microcontroller that resets the processor after a selectable length of time. The WDT is enabled or disabled and set up using Configuration bits.

### Workbook

For MPLAB SIM stimulator, a setup for generation of SCL stimulus.

# MPLAB<sup>®</sup> XC8 C Compiler User's Guide

---

NOTES:



## Index

### Symbols

|                                               |               |                                             |                   |
|-----------------------------------------------|---------------|---------------------------------------------|-------------------|
| __assembly label character .....              | 220, 272      | __serial0 label .....                       | 121               |
| __align qualifier .....                       | 32            | __STACK macro .....                         | 233               |
| __bank qualifier .....                        | 31            | __STRICT macro .....                        | 233               |
| __Bool type .....                             | 151           | __TIME__ macro .....                        | 233               |
| __builtin_software_breakpoint builtin .....   | 339           | __timeout variable .....                    | 213               |
| __Bxxx type symbols .....                     | 263           | __TRACE macro (REAL ICE) .....              | 147               |
| __conditional_software_breakpoint macro ..... | 340           | __TRADITIONAL18__ macro .....               | 234               |
| __CONFIG macro .....                          | 341, 342      | __XC macro .....                            | 234               |
| __DATABANK macro .....                        | 233           | __XC8 macro .....                           | 234               |
| __DATE__ macro .....                          | 233           | __XC8_VERSION macro .....                   | 234               |
| __DEBUG macro .....                           | 312, 340, 343 | __xdata qualifier .....                     | 31                |
| __debug_break macro .....                     | 343           | __ydata qualifier .....                     | 31                |
| __delay_ms macro .....                        | 343           | __16Fxxx type macros .....                  | 234               |
| __delay_us macro .....                        | 343           | __BANKBITS__ macro .....                    | 234               |
| __delaywdt_ms macro .....                     | 343           | __BANKCOUNT macro .....                     | 234               |
| __delaywdt_us macro .....                     | 343           | __COMMON__ macro .....                      | 234               |
| __deprecate qualifier .....                   | 37            | __delay function .....                      | 64, 237, 348, 349 |
| __eeprom qualifier .....                      | 33            | __EEPROM_INT macro .....                    | 234               |
| __EEPROM_DATA macro .....                     | 184, 344      | __EEPROMSIZE macro .....                    | 185, 234          |
| __EXTMEM macro .....                          | 233           | __ERRATA_TYPES macro .....                  | 108, 234          |
| __far qualifier .....                         | 28            | __FLASH_ERASE_SIZE macro .....              | 234               |
| __FILE__ macro .....                          | 233           | __FLASH_WRITE_SIZE macro .....              | 234               |
| __FLASHTYPE macro .....                       | 233           | __GPRBITS__ macro .....                     | 234               |
| __fpnormalize function .....                  | 345           | __GPRCOUNT__ macro .....                    | 234               |
| __Hxxx type symbols .....                     | 263           | __HAS_OSCVAL macro .....                    | 234               |
| __IDLOC macro .....                           | 143, 345      | __HTC_EDITION__ macro .....                 | 234               |
| __IDLOC7 macro .....                          | 143, 346      | __HTC_VER_MAJOR__ macro .....               | 234               |
| __interrupt qualifier .....                   | 34            | __HTC_VER_MINOR__ macro .....               | 234               |
| __J_PART macro .....                          | 233           | __HTC_VER_PATCH__ macro .....               | 234               |
| __LINE__ macro .....                          | 233           | __HTC_VER_PLVL__ macro .....                | 234               |
| __LOG macro (REAL ICE) .....                  | 147           | __MPC__ macro .....                         | 234               |
| __Lxxx type symbols .....                     | 263           | __OMNI_CODE__ macro .....                   | 234               |
| __MPLAB_ICD__ macro .....                     | 235           | __PIC12 macro .....                         | 234               |
| __MPLAB_ICDx__ macro .....                    | 233           | __PIC12E macro .....                        | 234               |
| __MPLAB_PICKITx__ macro .....                 | 233           | __PIC14 macro .....                         | 235               |
| __MPLAB_REALICE__ macro .....                 | 233           | __PIC14E macro .....                        | 235               |
| __near qualifier .....                        | 29            | __PIC18 macro .....                         | 235               |
| __OPTIMIZE_NONE__ macro .....                 | 233           | __PROGMEM__ macro .....                     | 235               |
| __OPTIMIZE_SIZE__ macro .....                 | 233           | __RAMSIZE macro .....                       | 235               |
| __OPTIMIZE_SPEED__ macro .....                | 233           | __READ_OSCCAL_DATA macro .....              | 146               |
| __osccal_val function .....                   | 347           | __ROMSIZE macro .....                       | 235               |
| __pack qualifier .....                        | 36            | ;; macro comment suppress character .....   | 288               |
| __persistent qualifier .....                  | 30            | ? assembly label character .....            | 272               |
| __PICC__ macro .....                          | 233           | ??nnnn type symbols .....                   | 273, 288          |
| __PICC18__ macro .....                        | 233           | . (dot) linker load address character ..... | 310               |
| __PICCPRO__ macro .....                       | 233           | .as files, see assembly files               |                   |
| __powerdown variable .....                    | 213           | .asm files, see assembly files              |                   |
| __resetbits variable .....                    | 213           | .cmd files, see command files               |                   |
| __RESETBITS_ADDR macro .....                  | 233           | .cmf files, see symbol files                |                   |
| __section qualifier .....                     | 37            | .cof files, see COFF files                  |                   |
|                                               |               | .d files, see dependency files              |                   |

# MPLAB® XC8 C Compiler User's Guide

|                                                       |                            |
|-------------------------------------------------------|----------------------------|
| .dep files, see dependency files                      |                            |
| .elf files, see ELF files                             |                            |
| .h files, see header files                            |                            |
| .hxl files, see hexmate log files                     |                            |
| .lpp files, see libraries, p-code                     |                            |
| .lst files, see assembly list files                   |                            |
| .map files, see map files                             |                            |
| .p1 files, see p-code files                           |                            |
| .pre files, see preprocessed files                    |                            |
| .pro files, see prototype files                       |                            |
| .sdb files, see debug information                     |                            |
| .sym files, see symbol files                          |                            |
| xxxx@yyyy type symbols                                | 221                        |
| @ address construct, see absolute variables/functions |                            |
| @ command file specifier                              | 78, 307                    |
| / psect address symbol                                | 310                        |
| \ command file character                              | 78                         |
| & macro concatenation character                       | 271, 287                   |
| && bitwise AND operator                               | 271                        |
| # preprocessor operator                               | 230                        |
| ## preprocessor operator                              | 230                        |
| #asm directive                                        | 219                        |
| #define directive                                     | 98                         |
| #endasm directive                                     | 219                        |
| #include directive                                    | 80, 99, 106, 121           |
| #pragma                                               |                            |
| addrqual                                              | 236                        |
| inline                                                | 237                        |
| interrupt_level                                       | 237                        |
| intrinsic                                             | 237                        |
| printf_check                                          | 237                        |
| regsused                                              | 238                        |
| switch                                                | 239                        |
| #undef directive                                      | 102                        |
| % macro argument prefix                               | 288                        |
| % message format placeholder character                | 92                         |
| - suboption                                           | 95                         |
| + suboption                                           | 95                         |
| <> macro argument characters                          | 271, 288                   |
| \$ assembly label character                           | 272                        |
| \$ location counter symbol                            | 273                        |
| <b>Numerics</b>                                       |                            |
| 0b binary radix specifier                             | 163                        |
| <b>A</b>                                              |                            |
| abs function                                          | 349                        |
| abs PSECT flag                                        | 226, 280                   |
| ABS1 class                                            | 258                        |
| absolute functions                                    | 27, 194                    |
| absolute object files                                 | 309                        |
| absolute psects                                       | 226, 280, 282              |
| absolute variables                                    | 27, 141, 181, 182–183, 286 |
| acos function                                         | 350                        |
| activation, see compiler installation & activation    |                            |
| addressable unit, see delta PSECT flag                |                            |
| addrqual pragma directive                             | 236                        |
| advisory messages                                     | 91, 114                    |
| alignment                                             |                            |
| of HEX file records                                   | 120                        |
| of psects, see reloc PSECT flag                       |                            |
| all suboption                                         | 95                         |
| anonymous structures and unions                       | 156                        |
| ANSI C standard                                       | 16                         |
| conformance                                           | 123, 135                   |
| divergence                                            | 135                        |
| implementation-defined behaviour                      | 136, 565–572               |
| APB                                                   | 177                        |
| arrays                                                | 173                        |
| and pointer sizes                                     | 158                        |
| as dummy pointer targets                              | 162                        |
| maximum size of                                       | 173                        |
| ASCII characters                                      | 150, 271                   |
| extended                                              | 164                        |
| asctime function                                      | 351                        |
| asin function                                         | 352                        |
| asm C statement                                       | 40, 219                    |
| ASMOPT control                                        | 291                        |
| assembler application                                 | 265–294                    |
| usage                                                 | 265                        |
| assembler controls                                    | 291–293                    |
| assembler directives                                  | 277–290                    |
| assembler macros                                      | 287                        |
| disabling in listing                                  | 292                        |
| expanding in listings                                 | 292                        |
| repeat with argument                                  | 289                        |
| repeating                                             | 289                        |
| suppressing comments                                  | 288                        |
| unnamed                                               | 289                        |
| assembler optimizations                               | 294                        |
| assembler optimizer                                   |                            |
| and list files                                        | 295                        |
| enabling                                              | 115, 291                   |
| saving state                                          | 291                        |
| selectively disabling                                 | 291                        |
| stack depth considerations                            | 301                        |
| assembler-generated symbols                           | 273                        |
| assembly code                                         |                            |
| called by C                                           | 216                        |
| generating from C                                     | 102                        |
| interaction with C                                    | 220                        |
| mixing with C                                         | 57, 216                    |
| optimizations                                         | 115                        |
| preprocessing                                         | 101, 230                   |
| stack overflow                                        | 75                         |
| writing                                               | 57–59                      |
| assembly constants                                    | 272                        |
| assembly files                                        | 80, 216                    |
| assembly language                                     |                            |
| absolute variables                                    | 286                        |
| access operands                                       | 266                        |
| accessing C objects                                   | 220                        |
| character set                                         | 271                        |
| comments                                              | 270, 271                   |
| common errors                                         | 59, 76                     |
| conditional                                           | 286                        |
| data types                                            | 273                        |
| delimiters                                            | 271                        |
| destination operands                                  | 266                        |
| differences in                                        | 266                        |
| expressions                                           | 275                        |

|                                     |                      |                                               |                        |
|-------------------------------------|----------------------|-----------------------------------------------|------------------------|
| include files .....                 | 292                  | bin directory.....                            | 82                     |
| initializing locations .....        | 285                  | binary constants                              |                        |
| label scope.....                    | 274, 278             | assembly.....                                 | 272                    |
| labels .....                        | 270, 274             | C code.....                                   | 163                    |
| location counter .....              | 273                  | bit access of variables.....                  | 54                     |
| operators.....                      | 275                  | bit data types.....                           | 149, 151               |
| pseudo-ops.....                     | 277                  | bit instructions.....                         | 143, 151               |
| registers.....                      | 59, 222, 273         | bit PSECT flag.....                           | 280                    |
| relative jumps.....                 | 273                  | bitclr macro.....                             | 143                    |
| repeating instructions.....         | 289                  | bit-fields.....                               | 24, 25, 54, 155–156    |
| reserving memory.....               | 226, 286             | bitset macro.....                             | 143                    |
| statement formats.....              | 270                  | bitwise complement operator.....              | 187                    |
| strings .....                       | 272                  | blinking an LED.....                          | 74                     |
| volatile objects .....              | 271                  | bootloaders .....                             | 61, 119, 120, 329      |
| assembly list files.....            | 69, 89, 103, 295–302 | requirements.....                             | 210                    |
| blank lines.....                    | 293                  | bsearch function.....                         | 358                    |
| content.....                        | 295                  | bss psect.....                                | 172, 212, 256          |
| excluding conditional code.....     | 292                  | btemp variables.....                          | 189, 206               |
| format.....                         | 292                  | building projects.....                        | 85                     |
| including conditional code.....     | 291                  | byte addressable memory.....                  | 280                    |
| macros.....                         | 292                  |                                               |                        |
| new page.....                       | 293                  | <b>C</b>                                      |                        |
| titles and subtitles.....           | 293                  | C identifiers.....                            | 149                    |
| assembly source files.....          | 80                   | C standard libraries.....                     | 214, 339–430           |
| assembly variables                  |                      | call depth, see stack depth                   |                        |
| C equivalent.....                   | 220                  | call graph.....                               | 138, 176, 208, 299–302 |
| defining.....                       | 285                  | CALL instruction.....                         | 269                    |
| global.....                         | 278                  | casting.....                                  | 48, 187                |
| identifiers.....                    | 272                  | CCI.....                                      | 109, 136               |
| initialized.....                    | 285                  | ceil function.....                            | 359                    |
| reserving memory.....               | 285                  | cgets function.....                           | 360                    |
| type.....                           | 273                  | char data types.....                          | 22, 150                |
| assert function.....                | 353                  | character constants                           |                        |
| atan function.....                  | 354                  | assembly.....                                 | 272                    |
| atan2 function.....                 | 354                  | in C.....                                     | 164                    |
| atof function.....                  | 355                  | checksum psect.....                           | 253                    |
| atoi function.....                  | 356                  | checksums.....                                | 104, 326               |
| atol function.....                  | 357                  | chipinfo file.....                            | 118, 119               |
| auto variables.....                 | 171, 174, 176, 299   | cinit psect.....                              | 253                    |
| assembly symbols.....               | 176                  | class PSECT flag.....                         | 280                    |
| initialization.....                 | 211                  | classes                                       |                        |
| memory allocation.....              | 174–178              | linker.....                                   | 257                    |
| size limits.....                    | 179                  | classes, see linker classes                   |                        |
| software stack.....                 | 178                  | clearing variables.....                       | 212                    |
| auto-parameter block.....           | 177                  | CLRWDT instruction.....                       | 64                     |
|                                     |                      | CLRWDT macro.....                             | 361                    |
| <b>B</b>                            |                      | CODE class.....                               | 258                    |
| banked memory.....                  | 68, 170, 283         | COFF files.....                               | 115                    |
| linear addressing.....              | 69, 173, 183         | command files.....                            | 78, 322                |
| number of available banks.....      | 234                  | linker.....                                   | 307                    |
| qualifiers for.....                 | 168                  | command-line driver, see driver               |                        |
| selection in assembly code.....     | 58, 218, 267, 289    | commands, see building projects, command-line |                        |
| BANKMASK macro.....                 | 58, 218              | common C interface, see CCI                   |                        |
| BANKSEL directive.....              | 58, 218              | COMMON class.....                             | 258                    |
| BANKx class.....                    | 258                  | common memory.....                            | 167, 170, 206          |
| bankx qualifiers.....               | 168                  | compilation                                   |                        |
| base specifier, see radix specifier |                      | assembly files.....                           | 86                     |
| base value.....                     | 178                  | incremental builds.....                       | 85                     |
| biased exponent.....                | 153                  | make files, see make files                    |                        |
| big endian format.....              | 326                  | mixed file types.....                         | 84                     |
| BIGRAM class.....                   | 258                  | sequence.....                                 | 81–85                  |

# MPLAB® XC8 C Compiler User's Guide

|                                          |                                  |                                      |                   |
|------------------------------------------|----------------------------------|--------------------------------------|-------------------|
| time .....                               | 124                              | DB directive .....                   | 285               |
| to assembly file .....                   | 102                              | DDW directive .....                  | 285               |
| to intermediate file .....               | 116                              | debug information                    |                   |
| to object file .....                     | 97                               | assembler .....                      | 219               |
| to preprocessed file .....               | 117                              | debuggers .....                      | 61, 106           |
| compiled specifier .....                 | 191                              | default psect .....                  | 276               |
| compiled stack .....                     | 138, 174, 176–178, 179, 191, 208 | default suboption .....              | 95                |
| base value .....                         | 178                              | delay routine .....                  | 64, 343           |
| compiler applications .....              | 81                               | delaywdt function .....              | 348               |
| compiler errors                          |                                  | delta PSECT flag .....               | 217, 280, 307     |
| format .....                             | 92                               | dependency file .....                | 106               |
| list of .....                            | 437–564                          | dependency files .....               | 121               |
| compiler installation & activation ..... | 43–44                            | device family macro .....            | 234               |
| compiler operating mode .....            | 13, 65, 113                      | device macros .....                  | 233               |
| compiler options, see driver options     |                                  | device selection .....               | 105, 310          |
| compiler selection .....                 | 46                               | device support .....                 | 69, 105, 137      |
| compiler-generated code .....            | 69                               | DI macro .....                       | 365               |
| compiler-generated psects .....          | 252–256                          | diagnostic files .....               | 89                |
| COND control .....                       | 291                              | directives, see assembler directives |                   |
| conditional assembly .....               | 286                              | disabling interrupts .....           | 62, 207           |
| CONFIG class .....                       | 259                              | div function .....                   | 366               |
| config pragma .....                      | 139                              | divide by zero .....                 | 567               |
| config psect .....                       | 253                              | Documentation                        |                   |
| configuration bits .....                 | 139                              | Conventions .....                    | 8                 |
| CONST class .....                        | 258                              | Layout .....                         | 7                 |
| const objects                            |                                  | doprint.c source file .....          | 214               |
| initialization .....                     | 166                              | doprint.pre file .....               | 117, 215          |
| storage location .....                   | 180                              | double data type .....               | 106, 152          |
| const psect .....                        | 253                              | driver .....                         | 77–125            |
| const qualifier .....                    | 166, 181                         | command file .....                   | 78                |
| constants                                |                                  | command format .....                 | 78                |
| assembly .....                           | 272                              | help on options .....                | 111               |
| C specifiers .....                       | 163                              | input files .....                    | 78                |
| character .....                          | 164                              | long command lines .....             | 78                |
| string, see string literals .....        | 164                              | single step compilation .....        | 84                |
| context switch code .....                | 56, 68, 194, 206, 238            | driver option                        |                   |
| control qualifier .....                  | 145                              | - .....                              | 95                |
| conversion between types .....           | 187                              | + .....                              | 95                |
| copyright notice .....                   | 101                              | ADDRQUAL .....                       | 103, 167, 168     |
| cos function .....                       | 361                              | all .....                            | 95                |
| cosh function .....                      | 362                              | ASMLIST .....                        | 89, 102, 103, 295 |
| cputs function .....                     | 363                              | C .....                              | 97                |
| CROMWELL application .....               | 88                               | CCI .....                            | 41                |
| crystal frequency .....                  | 343                              | CHECKSUM .....                       | 104               |
| cstack psect .....                       | 138, 256                         | CHIP .....                           | 105, 314          |
| ctime function .....                     | 364                              | CHIPINFO .....                       | 69, 105           |
| Customer Notification Service .....      | 10                               | CLIST .....                          | 105               |
| Customer Support .....                   | 10                               | CODEOFFSET .....                     | 61, 105           |
| <b>D</b>                                 |                                  | D .....                              | 98, 102           |
| DABS directive .....                     | 286                              | DEBUGGER .....                       | 106               |
| dat directory .....                      | 90                               | default .....                        | 95                |
| data memory .....                        | 170, 171, 182, 256, 280, 283     | DEP .....                            | 106               |
| data pointers .....                      | 158                              | DOUBLE .....                         | 106, 152          |
| data psect .....                         | 172, 256                         | E .....                              | 92, 98            |
| data stack .....                         | 138, 174                         | ECHO .....                           | 107               |
| data types                               |                                  | EMI .....                            | 107               |
| assembly .....                           | 273                              | ERRATA .....                         | 108               |
| floating point .....                     | 152–154                          | ERRFORMAT .....                      | 93, 109           |
| integer .....                            | 149–151                          | ERRORS .....                         | 90, 109, 314      |
| size of .....                            | 21, 149, 153                     | EXT .....                            | 109, 431          |

|                                |                   |                                           |               |
|--------------------------------|-------------------|-------------------------------------------|---------------|
| FILL.....                      | 104, 110          | EEPROM routines.....                      | 366           |
| FLOAT.....                     | 111               | EEPROM data psect.....                    | 253           |
| GETOPTION.....                 | 111               | EEPROM_read function.....                 | 185           |
| HELP.....                      | 111               | EEPROM_write function.....                | 185           |
| HTML.....                      | 111               | EI macro.....                             | 365           |
| I.....                         | 99                | ELF files.....                            | 115           |
| L.....                         | 99                | ELSE directive.....                       | 286           |
| L (linker options).....        | 100, 313, 315     | ELSIF directive.....                      | 286           |
| LANG.....                      | 91, 112           | enabling interrupts.....                  | 207           |
| M.....                         | 89, 100, 314      | END directive.....                        | 278           |
| MAXIPIC.....                   | 112               | endianism.....                            | 149, 152      |
| MEMMAP.....                    | 113               | ENDIF directive.....                      | 286           |
| MODE.....                      | 113               | ENDM directive.....                       | 287           |
| MSGDISABLE.....                | 93, 113           | ENTRY class.....                          | 258           |
| MSGFORMAT.....                 | 93, 109, 114      | entry point.....                          | 278           |
| N.....                         | 54, 101           | entry__ type symbols.....                 | 220           |
| NODEL.....                     | 84, 114           | environment variables.....                | 79            |
| NOFALLBACK.....                | 114               | EQU directive.....                        | 270, 273, 284 |
| none.....                      | 95                | equating assembly symbols.....            | 284           |
| O.....                         | 101               | errata workarounds.....                   | 108           |
| OBJDIR.....                    | 114               | ERRATA_4000_BOUNDARY macro.....           | 235           |
| OPT.....                       | 115               | errata.h header file.....                 | 108           |
| OUTDIR.....                    | 114, 115          | error counter.....                        | 90            |
| OUTPUT.....                    | 88, 115           | error files.....                          | 308           |
| P.....                         | 101, 222, 230     | error messages.....                       | 73, 90–94     |
| PARSER.....                    | 116               | format.....                               | 92, 109       |
| PASS1.....                     | 116               | language.....                             | 112           |
| PRE.....                       | 117, 230          | list of.....                              | 437–564       |
| PROTO.....                     | 117               | location.....                             | 73            |
| Q.....                         | 101               | maximum number of.....                    | 109           |
| RAM.....                       | 118               | eval_poly function.....                   | 367           |
| ROM.....                       | 119               | exp function.....                         | 367           |
| RUNTIME.....                   | 87, 120, 146, 198 | EXPAND control.....                       | 288, 292      |
| S.....                         | 102               | exponent.....                             | 152           |
| SCANDEP.....                   | 121               | extended character set.....               | 164           |
| SERIAL.....                    | 121               | extended instruction set.....             | 137           |
| SETUP.....                     | 91, 112           | extensions.....                           | 80            |
| SHROUD.....                    | 122               | external functions.....                   | 192           |
| STACK.....                     | 122               | external memory.....                      | 168           |
| STRICT.....                    | 123               | EXTRN directive.....                      | 284           |
| SUMMARY.....                   | 124               | <b>F</b>                                  |               |
| TIME.....                      | 124               | F constant suffix.....                    | 164           |
| U.....                         | 102               | fabs function.....                        | 368           |
| V.....                         | 102               | far qualifier.....                        | 168           |
| WARN.....                      | 93, 125           | fatal error messages.....                 | 91            |
| WARNFORMAT.....                | 93, 109, 125      | FCALL pseudo instruction.....             | 269           |
| driver options.....            | 47, 78, 95–125    | fcall pseudo instruction.....             | 58            |
| DS directive.....              | 285               | file extensions.....                      | 80            |
| DW directive.....              | 285               | file types                                |               |
| DWARF files, see ELF files     |                   | assembly listing, see assembly list files |               |
| dynamic memory allocation..... | 186               | command.....                              | 78, 307, 322  |
| <b>E</b>                       |                   | dependency.....                           | 121           |
| EEDATA class.....              | 259               | input.....                                | 78            |
| EEPROM                         |                   | intermediate.....                         | 114           |
| data.....                      | 184               | intermediate, see intermediate files      |               |
| EEPROM memory                  |                   | library, see libraries                    |               |
| initializing.....              | 184               | object, see object files                  |               |
| reading.....                   | 185               | preprocessed.....                         | 117           |
| writing.....                   | 185               | prototype.....                            | 117           |
| EEPROM psect.....              | 253               |                                           |               |
| EEPROM qualifier.....          | 169, 184          |                                           |               |

# MPLAB® XC8 C Compiler User's Guide

|                                       |                    |                                                      |              |
|---------------------------------------|--------------------|------------------------------------------------------|--------------|
| symbol.....                           | 308                | device.....                                          | 137, 141     |
| filling unused memory.....            | 62, 104, 110       | search path.....                                     | 99           |
| fixup overflow errors.....            | 76, 312, 313       | help!.....                                           | 43, 111      |
| flash functions.....                  | 368                | hex files.....                                       | 80, 82, 323  |
| Fletcher's checksum algorithm.....    | 104, 326           | address alignment.....                               | 120          |
| float data type.....                  | 111, 152           | addresses.....                                       | 280          |
| floating-point constant suffixes..... | 164                | data record.....                                     | 120, 325     |
| floating-point rounding.....          | 53                 | embedding serial numbers.....                        | 330          |
| floating-point types.....             | 106, 111, 152–154  | embedding strings.....                               | 331          |
| biased exponent.....                  | 153                | extended address record.....                         | 329          |
| exponent.....                         | 153                | filling unused memory.....                           | 110          |
| relaxed.....                          | 152, 345           | format.....                                          | 329          |
| rounding.....                         | 153                | merging.....                                         | 61, 323      |
| floor function.....                   | 369                | multiple.....                                        | 308          |
| fmod function.....                    | 369                | record length.....                                   | 120, 329     |
| fpbase symbol.....                    | 161                | renaming.....                                        | 101          |
| frexp function.....                   | 370                | statistics.....                                      | 329          |
| ftoa function.....                    | 371                | hexadecimal constants                                |              |
| function                              |                    | assembly.....                                        | 272          |
| calling convention.....               | 198                | C code.....                                          | 163          |
| duplication.....                      | 208–209            | HEXMATE application.....                             | 82, 323      |
| parameters.....                       | 174, 195, 196, 216 | hexmate log files.....                               | 324, 329     |
| pointers.....                         | 160                | HEXMATE options.....                                 | 325–331      |
| prototypes.....                       | 262, 290           | HI_TECH_C macro.....                                 | 235          |
| return bank.....                      | 199                | HLINK application.....                               | 305          |
| return values.....                    | 197                | HTC_ERR_FORMAT environment variable.....             | 92           |
| signatures.....                       | 262, 290           | HTC_MSG_FORMAT environment variable.....             | 92           |
| size limits.....                      | 195                | HTC_WARN_FORMAT environment variable.....            | 92           |
| specifiers.....                       | 190                | HTML files.....                                      | 111          |
| stack usage.....                      | 198                | <b>I</b>                                             |              |
| functions                             |                    | IAR compatibility.....                               | 431–436      |
| absolute.....                         | 27, 194            | IAR extensions.....                                  | 109          |
| creating prototypes.....              | 117                | ICD, see debuggers                                   |              |
| external.....                         | 192                | ID Locations.....                                    | 142          |
| inline.....                           | 190                | idata psect.....                                     | 172, 253     |
| interrupt, see interrupt functions    |                    | identifiers                                          |              |
| location of.....                      | 70                 | assembly.....                                        | 272          |
| reentrant.....                        | 191                | C.....                                               | 149          |
| size of.....                          | 55                 | unique length of.....                                | 21, 54, 101  |
| static.....                           | 190                | IDLOC class.....                                     | 259          |
| written in assembler.....             | 216                | idloc psect.....                                     | 253          |
| <b>G</b>                              |                    | IEEE floating-point format, see floating-point types | 152          |
| get_cal_data function.....            | 375                | IF directive.....                                    | 286          |
| getch function.....                   | 372                | implementation-defined behaviour.....                | 136, 565–572 |
| getchar function.....                 | 373                | INCLUDE control.....                                 | 292          |
| getche function.....                  | 372                | include files, see header files                      |              |
| gets function.....                    | 374                | incremental builds.....                              | 85           |
| glitches on ports.....                | 60                 | INHX32 hex files.....                                | 325, 329     |
| GLOBAL directive.....                 | 57, 217, 274, 278  | INHX8M hex files.....                                | 325, 329     |
| global PSECT flag.....                | 280                | init psect.....                                      | 253          |
| gmtime function.....                  | 376                | initialized variables.....                           | 120, 211     |
| GOTO instruction.....                 | 269                | inline functions.....                                | 190          |
| <b>H</b>                              |                    | inline pragma directive.....                         | 237          |
| hardware errata.....                  | 108                | inline PSECT flag.....                               | 281          |
| hardware multiply instructions.....   | 144                | input files.....                                     | 78           |
| hardware stack.....                   | 138                | installation, see compiler installation & activation |              |
| header file                           |                    | instruction set.....                                 | 137          |
| search path.....                      | 20                 | instrumented trace.....                              | 147          |
| header files.....                     | 19, 215            | int types.....                                       | 149          |
|                                       |                    | intcode psect.....                                   | 254          |

|                                       |                      |                                         |                    |
|---------------------------------------|----------------------|-----------------------------------------|--------------------|
| integer constants.....                | 163                  | linking.....                            | 305, 311           |
| integer suffixes.....                 | 163                  | listing modules & symbols in.....       | 321                |
| integral promotion.....               | 187                  | module order.....                       | 322                |
| Intel HEX files, see hex files        |                      | obfuscating.....                        | 122                |
| intentry psect.....                   | 254                  | object.....                             | 82, 313, 315, 320  |
| intermediate files.....               | 78, 81, 82, 114, 116 | p-code.....                             | 82, 87, 320        |
| assembly.....                         | 86                   | replacing modules in.....               | 215, 261           |
| Internet Address.....                 | 9                    | scanning additional.....                | 99                 |
| interrupt                             |                      | search order.....                       | 78                 |
| sources.....                          | 201                  | user-defined.....                       | 215                |
| vectors.....                          | 105                  | library functions.....                  | 339–430            |
| interrupt functions.....              | 202                  | limit PSECT flag.....                   | 281, 311           |
| context switching.....                | 206, 207, 238        | limits.h header file.....               | 149                |
| moving.....                           | 105, 194             | linear data memory.....                 | 69, 170, 183       |
| optimizations.....                    | 68                   | link addresses.....                     | 310                |
| interrupt qualifier.....              | 202                  | linker classes.....                     | 118, 119, 257, 280 |
| interrupt_level pragma directive..... | 237                  | address limit.....                      | 311                |
| interrupts.....                       | 56                   | address ranges.....                     | 307                |
| context switching.....                | 56, 68, 194          | adjusting.....                          | 118, 119           |
| disabling.....                        | 62, 207              | boundary argument.....                  | 311                |
| enabling.....                         | 207                  | linker options.....                     | 305, 305–312, 315  |
| intrinsic pragma directive.....       | 237                  | adjusting.....                          | 100                |
| IRP directive.....                    | 289                  | viewing.....                            | 315                |
| IRPC directive.....                   | 289                  | linker scripts.....                     | 241                |
| isalnum function.....                 | 377                  | linker-defined symbols.....             | 263                |
| isalpha function.....                 | 377                  | linking projects.....                   | 241                |
| isdigit function.....                 | 378                  | LIST control.....                       | 292                |
| isdigit function.....                 | 377                  | LITE mode, see compiler operating mode  |                    |
| isgraph function.....                 | 377                  | little endian format.....               | 149, 152, 326      |
| islower function.....                 | 377                  | LJMP pseudo instruction.....            | 269                |
| isprint function.....                 | 377                  | ljmp pseudo instruction.....            | 58                 |
| ispunct function.....                 | 377                  | load addresses.....                     | 310                |
| isspace function.....                 | 377                  | LOCAL directive.....                    | 273                |
| isupper function.....                 | 377                  | local PSECT flag.....                   | 281                |
| isxdigit function.....                | 377                  | localtime function.....                 | 381                |
| itoa function.....                    | 378                  | location counter.....                   | 273, 284           |
| <b>J</b>                              |                      | log function.....                       | 382                |
| jmp_tab psect.....                    | 254                  | log10 function.....                     | 382                |
| <b>K</b>                              |                      | long double types.....                  | 152                |
| keep PSECT flag.....                  | 281                  | long int types.....                     | 149                |
| keywords, see qualifiers              |                      | longjmp function.....                   | 383                |
| <b>L</b>                              |                      | ltemp variables.....                    | 189                |
| L constant suffix.....                | 163                  | ltoa function.....                      | 384                |
| l.obj file.....                       | 309                  | <b>M</b>                                |                    |
| labels, assembly.....                 | 270, 274             | macro concatenation.....                | 230                |
| labs function.....                    | 379                  | MACRO directive.....                    | 270, 287           |
| language support.....                 | 91                   | main function.....                      | 19, 87, 210        |
| ldexp function.....                   | 379                  | main-line code.....                     | 177, 201           |
| ldiv function.....                    | 380                  | maintext psect.....                     | 193, 254           |
| LED, blinking.....                    | 74                   | make files.....                         | 78, 83, 85         |
| lib directory.....                    | 87, 99, 214          | managed stack.....                      | 198                |
| LIBR application, see librarian       |                      | mantissa.....                           | 152                |
| librarian.....                        | 215, 261, 320–322    | map files.....                          | 89, 309, 314–318   |
| libraries.....                        | 87                   | maximum (unique) identifier length..... | 101                |
| adding files to.....                  | 321                  | MDF.....                                | 90                 |
| creating.....                         | 46, 321              | mediumconst psect.....                  | 254                |
| deleting modules from.....            | 321                  | memchr function.....                    | 385                |
| format of.....                        | 320                  | memcmp function.....                    | 386                |
|                                       |                      | memcpy function.....                    | 387                |
|                                       |                      | memmove function.....                   | 388                |

# MPLAB® XC8 C Compiler User's Guide

|                                  |                         |
|----------------------------------|-------------------------|
| memory                           |                         |
| banks, see banked memory         |                         |
| common                           | 167, 170, 206           |
| data                             | 170, 182, 256, 280, 283 |
| linear data                      | 170                     |
| pages                            | 267, 269, 283, 289      |
| remaining                        | 70                      |
| reserving                        | 52, 70, 105, 118, 119   |
| specifying ranges                | 307                     |
| summary                          | 70, 124                 |
| unbanked                         | 170                     |
| unused                           | 110                     |
| memory allocation                | 170                     |
| data memory                      | 171                     |
| dynamic                          | 186                     |
| function code                    | 193                     |
| non-auto variables               | 171                     |
| program memory                   | 180                     |
| static variables                 | 172                     |
| memory models                    | 186                     |
| memset function                  | 388                     |
| merge PSECT flag                 | 281, 283                |
| merging hex files                | 325                     |
| message description files        | 90                      |
| messages                         | 90–94                   |
| advisory                         | 91, 114                 |
| disabling                        | 90, 93, 113, 239        |
| error, see error messages        |                         |
| fatal error                      | 91                      |
| format                           | 92                      |
| ID number                        | 90                      |
| language                         | 91, 112                 |
| list of                          | 437–564                 |
| meaning                          | 73                      |
| placeholders in                  | 92                      |
| types of                         | 91                      |
| warning level of                 | 93                      |
| warning, see warning messages    |                         |
| messaging system                 | 90–94                   |
| appending messages to file       | 98                      |
| default language                 | 91                      |
| default warning level            | 93                      |
| environment variables            | 92                      |
| message count                    | 90                      |
| redirecting messages to file     | 98                      |
| supported languages              | 91                      |
| Microchip COF file               | 115                     |
| Microchip Internet Web Site      | 9                       |
| mktime function                  | 389                     |
| modf function                    | 390                     |
| modules                          | 80                      |
| generating                       | 117                     |
| MOVFW instruction                | 268                     |
| MPLAB IDE                        |                         |
| build options                    | 47, 100                 |
| compiler operating mode          | 46                      |
| compiler selection               | 46                      |
| search path                      | 99                      |
| MPLAB X IDE                      |                         |
| build options                    | 126                     |
| multi-byte SFRs                  | 142                     |
| multiply instructions            | 144                     |
| <b>N</b>                         |                         |
| native trace                     | 147                     |
| NDEBUG macro                     | 340                     |
| near qualifier                   | 167                     |
| NOCOND control                   | 292                     |
| noexec PSECT flag                | 281                     |
| NOEXPAND control                 | 292                     |
| NOLIST control                   | 292                     |
| none suboption                   | 95                      |
| nonreentrant specifier           | 191                     |
| non-volatile RAM                 | 166                     |
| NOP function                     | 390                     |
| NOP macro                        | 390                     |
| NULL macro                       | 26                      |
| null macro operator              | 288                     |
| NULL pointers                    | 161, 162                |
| nv psect                         | 172, 256                |
| <b>O</b>                         |                         |
| object code version number       | 314                     |
| object file libraries            | 313                     |
| object files                     | 82, 86, 97, 320         |
| absolute                         | 309                     |
| contents                         | 313                     |
| relocatable                      | 313                     |
| symbol only                      | 308                     |
| OBJTOHEX application             | 323                     |
| operator, cast                   | 48                      |
| OPT control directive            | 291                     |
| optim PSECT flag                 | 282                     |
| optimizations                    | 113, 115, 228           |
| assembler                        | 115                     |
| causing corruption               | 62                      |
| code size                        | 66                      |
| data size                        | 67                      |
| debugging                        | 115                     |
| faster code                      | 67                      |
| interrupt functions              | 68                      |
| speed vs space                   | 115                     |
| option instruction               | 145                     |
| options, see driver options      |                         |
| ORG directive                    | 226, 284                |
| oscillator calibration constants | 63, 146–147, 212        |
| preserving                       | 147                     |
| output file format               |                         |
| binary                           | 116                     |
| library                          | 116                     |
| specifying                       | 115                     |
| output files                     | 101, 115                |
| directory                        | 115                     |
| names of                         | 88                      |
| renaming                         | 101                     |
| specifying name of               | 101                     |
| overlaid memory areas            | 309                     |
| overlaid psects                  | 282                     |
| ovrld PSECT flag                 | 226, 282                |



## P

PAGE control ..... 293  
 paged memory ..... 267, 269, 283, 289  
     selection in assembly code ..... 58  
 PAGESEL directive ..... 58, 267, 289  
 parameters, see function, parameters  
 PATH environment variable ..... 79  
 p-code files ..... 78, 82, 83, 116  
     obfuscating ..... 122  
 p-code libraries, see libraries, p-code  
 persistent qualifier ..... 167, 211, 212  
 phase errors ..... 280  
 picc.ini file ..... 118, 119  
 pointer  
     comparisons ..... 162  
     definitions ..... 156  
     encoding ..... 160  
     qualifiers ..... 156  
     targets ..... 158  
     types ..... 156  
 pointer reference graph ..... 158, 298  
 pointers ..... 156–161, 170  
     assigning dummy targets ..... 161  
     assigning integers ..... 161  
     data ..... 158  
     function ..... 160  
 pow function ..... 391  
 powerup label ..... 211  
 powerup psect ..... 213, 254  
 powerup routine ..... 87, 210, 213  
 powerup.as ..... 213  
 pragma directives ..... 236  
 preprocessed files ..... 82, 117, 230  
 preprocessing ..... 230  
     assembler files ..... 101  
 preprocessor  
     macro concatenation ..... 230  
     search path ..... 99  
     types ..... 232  
 preprocessor directives ..... 230–232  
     in assembly files ..... 101, 270  
 preprocessor macros  
     containing strings ..... 98  
     defining ..... 98  
     predefined ..... 39, 233  
     undefining ..... 102  
     unique length of ..... 101  
 printf function ..... 63, 86, 214, 392  
     format checking ..... 237  
     preprocessing ..... 117  
 printf\_check pragma directive ..... 237  
 PRO mode, see compiler operating mode  
 processor selection ..... 105, 310  
 program counter ..... 273  
 program entry point ..... 213  
 program memory ..... 180, 280  
     absolute variables ..... 166, 183  
 project name ..... 88  
 projects ..... 85  
     assembly files ..... 86

prototype files ..... 117  
 psect  
     absolute ..... 226  
     bss ..... 172, 212, 256  
     checksum ..... 253  
     cinit ..... 253  
     config ..... 253  
     const ..... 253  
     cstack ..... 256  
     data ..... 172, 256  
     default ..... 276  
     eeprom ..... 253  
     eeprom\_data ..... 253  
     grouping ..... 280, 281  
     idata ..... 253  
     idloc ..... 253  
     init ..... 253  
     intcode ..... 254  
     intentry ..... 254  
     jmp\_tab ..... 254  
     maintext ..... 193, 254  
     mediumconst ..... 254  
     powerup ..... 213, 254  
     reset\_vec ..... 254  
     reset\_wrap ..... 255  
     smallconst ..... 255  
     stack ..... 256  
     strings ..... 255  
     stringtext ..... 255  
     temp ..... 255  
     textn ..... 193, 216, 255  
     xxx\_text ..... 194, 255  
 psect association ..... 280  
 PSECT directive ..... 59, 279  
 PSECT flags ..... 280–283  
 psects ..... 313  
     absolute ..... 280, 282  
     alignment of, see reloc PSECT flag  
     class ..... 307, 311  
     compiler-generated ..... 252–256  
     delta value ..... 307  
     function ..... 193  
     linking ..... 313  
     listing ..... 124  
     maximum address ..... 281  
     maximum size ..... 283  
     overlaid ..... 282  
     page boundaries and ..... 283  
     placing in memory ..... 280, 310  
     placing with others ..... 283  
     specifying addresses ..... 307, 310  
     splitting ..... 193  
 pseudo-ops, see assembler directives  
 pure PSECT flag ..... 282  
 putch function ..... 63  
 putchar function ..... 395, 396  
 puts function ..... 397  
**Q**  
 qsort function ..... 398  
 qualifier ..... 169

# MPLAB® XC8 C Compiler User's Guide

|                                    |                       |                                            |                   |
|------------------------------------|-----------------------|--------------------------------------------|-------------------|
| __align .....                      | 32                    | REPT directive .....                       | 289               |
| __bank .....                       | 31                    | reserving memory.....                      | 70, 105, 118, 119 |
| __deprecated .....                 | 37                    | reset .....                                | 167               |
| __eeprom .....                     | 33                    | code executed after.....                   | 62, 87, 210, 213  |
| __far .....                        | 28                    | determining cause.....                     | 213               |
| __interrupt .....                  | 34                    | vector .....                               | 105               |
| __near .....                       | 29                    | RESET macro .....                          | 400               |
| __pack .....                       | 36                    | reset_vec label .....                      | 211               |
| __persistent .....                 | 30                    | reset_vec psect .....                      | 254               |
| __section .....                    | 37                    | reset_wrap psect .....                     | 255               |
| __xdata .....                      | 31                    | RETFIE instruction .....                   | 269               |
| __ydata .....                      | 31                    | RETLW instruction .....                    | 180               |
| auto .....                         | 174                   | return values, see function, return values |                   |
| bankx .....                        | 168                   | returning from interrupts .....            | 269               |
| const .....                        | 166, 181              | rotate operator.....                       | 64, 188           |
| control .....                      | 145                   | round function.....                        | 401               |
| eeprom .....                       | 169                   | runtime startup code.....                  | 87, 210, 253, 313 |
| far .....                          | 168                   | assembly listing .....                     | 103               |
| interrupt .....                    | 202                   | preserving variables .....                 | 167               |
| near .....                         | 167                   | variable initialization .....              | 211               |
| persistent .....                   | 167, 211, 212         | runtime startup module.....                | 120               |
| special .....                      | 167                   | <b>S</b>                                   |                   |
| volatile .....                     | 60, 62, 166, 227, 271 | safeguarding code .....                    | 62, 122           |
| qualifiers .....                   | 166–168               | scale value .....                          | 280               |
| and auto variables .....           | 174                   | search path, see header files              |                   |
| and structures .....               | 154                   | sections, see psects                       |                   |
| disabling non-ANSI C .....         | 123                   | segment selector .....                     | 308               |
| quiet mode .....                   | 101                   | serial numbers .....                       | 121, 330          |
| <b>R</b>                           |                       | embedding .....                            | 330               |
| radix specifiers                   |                       | SET directive .....                        | 270, 284          |
| assembly .....                     | 272                   | setjmp function .....                      | 402               |
| C code .....                       | 163                   | SFRs .....                                 | 141               |
| RAM banks, see banked memory       |                       | accessing in assembly .....                | 222               |
| RAM class .....                    | 258                   | SFRx class .....                           | 258               |
| rand function .....                | 399                   | shadow registers .....                     | 206, 269          |
| reading timer registers.....       | 142                   | shift operator .....                       | 567               |
| Reading, Recommended.....          | 9                     | short int types .....                      | 149               |
| Readme.....                        | 9                     | sign bit .....                             | 152               |
| read-modify-write problems.....    | 75                    | SIGNAT directive.....                      | 217, 262, 290     |
| read-only variables .....          | 166                   | signatures.....                            | 262, 290          |
| READTIMERx macro .....             | 400                   | silicon errata .....                       | 108               |
| REAL ICE In-Circuit Emulator ..... | 147                   | sin function .....                         | 403               |
| REALICE, see debuggers             |                       | single step compilation .....              | 83, 84            |
| rebuilding projects .....          | 85                    | sinh function .....                        | 362               |
| reentrant functions .....          | 176, 191, 208         | size limits .....                          | 68                |
| reentrant specifier .....          | 191                   | auto variables .....                       | 179               |
| registers                          |                       | const variables .....                      | 181               |
| allocation to.....                 | 186                   | non-auto variables.....                    | 173               |
| in assembly code .....             | 273                   | size of types .....                        | 106, 149, 153     |
| special function .....             | 273                   | size PSECT flag .....                      | 283               |
| temporary .....                    | 189                   | SLEEP macro .....                          | 404               |
| used by functions .....            | 70, 189, 219          | smallconst psect.....                      | 255               |
| registry .....                     | 79                    | software breakpoint .....                  | 339, 343          |
| regsused pragma directive.....     | 238                   | software specifier .....                   | 191               |
| relative branch instructions.....  | 270                   | software stack .....                       | 138, 174, 191     |
| relative jump .....                | 273                   | source files .....                         | 80                |
| relaxed floating-point rules ..... | 152, 345              | sources directory .....                    | 213               |
| reloc PSECT flag.....              | 250, 283              | SPACE control .....                        | 293               |
| relocatable object files.....      | 313                   | space PSECT flag .....                     | 283               |
| replacing library modules .....    | 261                   | special function registers, see SFRs       |                   |

|                                       |                                  |                                        |               |
|---------------------------------------|----------------------------------|----------------------------------------|---------------|
| special type qualifiers .....         | 167                              | struct types, see structures           |               |
| specifiers, see qualifiers            |                                  | structure bit-fields .....             | 155           |
| sports cars .....                     | 273                              | structure qualifiers .....             | 154           |
| sprintf function .....                | 404                              | structures .....                       | 154           |
| sqrt function .....                   | 405                              | anonymous .....                        | 156           |
| srand function .....                  | 406                              | bit-fields in .....                    | 54, 155       |
| stack                                 |                                  | maximum size of .....                  | 173           |
| compiled .....                        | 138, 174, 176–178, 179, 191, 208 | SUBTITLE control .....                 | 293           |
| data .....                            | 138, 174                         | supported devices, see device, support |               |
| hardware .....                        | 138                              | switch pragma directive .....          | 239           |
| managed .....                         | 198                              | switch statement .....                 | 239           |
| selecting .....                       | 191                              | switch statements .....                | 188           |
| software .....                        | 138, 174, 178, 191               | symbol files .....                     | 308, 309, 310 |
| stack depth .....                     | 301                              | symbol tables .....                    | 311           |
| stack overflow .....                  | 75, 138                          | sorting .....                          | 309           |
| stack pointer .....                   | 179                              | symbol-only object file .....          | 308           |
| stack psect .....                     | 138, 256                         | symbols                                |               |
| standard library files                |                                  | assembler-generated .....              | 273           |
| start label .....                     | 211, 213                         | linker defined .....                   | 263           |
| start record .....                    | 278                              | undefined .....                        | 311           |
| start_initialization .....            | 211                              | <b>T</b>                               |               |
| startup module .....                  | 87, 120                          | tan function .....                     | 422           |
| startup.as, see startup module        |                                  | tanh function .....                    | 362           |
| static functions .....                | 190, 220                         | target device, see device, selection   |               |
| static variables .....                | 172, 211, 221                    | temp psect .....                       | 255           |
| STATUS register, preserving .....     | 213                              | temporary registers .....              | 189           |
| STD mode, see compiler operating mode |                                  | temporary variables .....              | 174           |
| storage duration .....                | 171                              | textn psect .....                      | 193, 216, 255 |
| strcat function .....                 | 407                              | time function .....                    | 423           |
| strchr function .....                 | 408                              | time to build .....                    | 124           |
| strcmp function .....                 | 409                              | TITLE control .....                    | 293           |
| STRCODE class .....                   | 258                              | toascii function .....                 | 424           |
| strcpy function .....                 | 410                              | tolower function .....                 | 424           |
| strcspn function .....                | 411                              | toupper function .....                 | 424           |
| strchr function .....                 | 408                              | trace features .....                   | 147           |
| stricmp function .....                | 409                              | tracked objects .....                  | 199           |
| string (strxxx) functions .....       | 407–421                          | translation units .....                | 80, 117       |
| STRING class .....                    | 258                              | tris instruction .....                 | 145           |
| string literals .....                 | 164                              | trunc function .....                   | 425           |
| assembly .....                        | 272                              | ttemp variables .....                  | 189           |
| concatenation .....                   | 165                              | type conversions .....                 | 48, 187       |
| packing .....                         | 331                              | types, see data types                  |               |
| storage location .....                | 165, 331                         | <b>U</b>                               |               |
| type of .....                         | 164                              | U constant suffix .....                | 163           |
| strings psect .....                   | 255                              | udiv function .....                    | 425           |
| stringtext psect .....                | 255                              | uldiv function .....                   | 426           |
| stristr function .....                | 418                              | unbanked memory, see memory, common    |               |
| strlen function .....                 | 412                              | undefined symbols .....                | 227           |
| strncat function .....                | 413                              | adding .....                           | 311           |
| strncmp function .....                | 414                              | undefining macros .....                | 102           |
| strncpy function .....                | 415                              | uninitialized variables .....          | 212           |
| strnicmp function .....               | 414                              | unions                                 |               |
| strpbrk function .....                | 416                              | anonymous .....                        | 156           |
| strchr function .....                 | 417                              | qualifiers .....                       | 154           |
| strchr function .....                 | 417                              | unnamed bit-fields .....               | 155           |
| strchr function .....                 | 417                              | unnamed psect .....                    | 276           |
| strcspn function .....                | 418                              | unnamed structure members .....        | 155           |
| strstr function .....                 | 418                              | unused memory .....                    | 70            |
| strtod function .....                 | 419                              | filling .....                          | 104           |
| strtok function .....                 | 421                              |                                        |               |
| strtol function .....                 | 420                              |                                        |               |

# MPLAB® XC8 C Compiler User's Guide

---

|                        |     |
|------------------------|-----|
| unused variables ..... | 227 |
| removing .....         | 166 |
| USB .....              | 590 |
| utoa function .....    | 427 |

## V

|                                 |                       |
|---------------------------------|-----------------------|
| va_arg function .....           | 428                   |
| va_end function .....           | 428                   |
| va_start function .....         | 428                   |
| value .....                     | 234                   |
| variable names, see identifiers |                       |
| variables                       |                       |
| absolute .....                  | 27, 182               |
| accessing from assembler .....  | 220                   |
| auto .....                      | 174                   |
| in assembly .....               | 285                   |
| in program memory .....         | 52, 180–181           |
| in registers .....              | 186                   |
| initialization .....            | 211                   |
| location of .....               | 70                    |
| maximum size of .....           | 68                    |
| sizes .....                     | 149, 153              |
| static .....                    | 172                   |
| storage duration .....          | 171                   |
| verbose output .....            | 102                   |
| version number .....            | 125                   |
| volatile qualifier .....        | 60, 62, 166, 227, 271 |

## W

|                               |          |
|-------------------------------|----------|
| warning level .....           | 93       |
| setting .....                 | 311      |
| warning messages .....        | 73, 91   |
| disabling .....               | 113, 239 |
| format .....                  | 125      |
| level displayed .....         | 125      |
| location .....                | 73       |
| suppressing .....             | 74, 311  |
| threshold level .....         | 125      |
| Warranty Registration .....   | 9        |
| watch dog timer .....         | 74       |
| Watchdog Timer .....          | 591      |
| windows registry .....        | 79       |
| with PSECT flag .....         | 283      |
| withtotal .....               | 283      |
| word addressable memory ..... | 280      |
| word boundaries .....         | 283      |
| WRITETIMERx macro .....       | 429      |
| wtemp variables .....         | 189      |
| WWW Address .....             | 9        |

## X

|                                   |               |
|-----------------------------------|---------------|
| XC_XML environment variable ..... | 79            |
| xc.h header file .....            | 137           |
| xc.inc assembly header file ..... | 216, 222, 273 |
| xc.xml XML file .....             | 79            |
| XC8 application .....             | 78            |
| XML files .....                   | 79            |
| xtal frequency .....              | 343           |
| xtoi function .....               | 430           |

NOTES:



# MICROCHIP

## Worldwide Sales and Service

### AMERICAS

**Corporate Office**  
2355 West Chandler Blvd.  
Chandler, AZ 85224-6199  
Tel: 480-792-7200  
Fax: 480-792-7277  
Technical Support:  
<http://www.microchip.com/support>  
Web Address:  
[www.microchip.com](http://www.microchip.com)

**Atlanta**  
Duluth, GA  
Tel: 678-957-9614  
Fax: 678-957-1455

**Austin, TX**  
Tel: 512-257-3370

**Boston**  
Westborough, MA  
Tel: 774-760-0087  
Fax: 774-760-0088

**Chicago**  
Itasca, IL  
Tel: 630-285-0071  
Fax: 630-285-0075

**Dallas**  
Addison, TX  
Tel: 972-818-7423  
Fax: 972-818-2924

**Detroit**  
Novi, MI  
Tel: 248-848-4000

**Houston, TX**  
Tel: 281-894-5983

**Indianapolis**  
Noblesville, IN  
Tel: 317-773-8323  
Fax: 317-773-5453  
Tel: 317-536-2380

**Los Angeles**  
Mission Viejo, CA  
Tel: 949-462-9523  
Fax: 949-462-9608  
Tel: 951-273-7800

**Raleigh, NC**  
Tel: 919-844-7510

**New York, NY**  
Tel: 631-435-6000

**San Jose, CA**  
Tel: 408-735-9110  
Tel: 408-436-4270

**Canada - Toronto**  
Tel: 905-695-1980  
Fax: 905-695-2078

### ASIA/PACIFIC

**Asia Pacific Office**  
Suites 3707-14, 37th Floor  
Tower 6, The Gateway  
Harbour City, Kowloon

**Hong Kong**  
Tel: 852-2943-5100  
Fax: 852-2401-3431

**Australia - Sydney**  
Tel: 61-2-9868-6733  
Fax: 61-2-9868-6755

**China - Beijing**  
Tel: 86-10-8569-7000  
Fax: 86-10-8528-2104

**China - Chengdu**  
Tel: 86-28-8665-5511  
Fax: 86-28-8665-7889

**China - Chongqing**  
Tel: 86-23-8980-9588  
Fax: 86-23-8980-9500

**China - Dongguan**  
Tel: 86-769-8702-9880

**China - Guangzhou**  
Tel: 86-20-8755-8029

**China - Hangzhou**  
Tel: 86-571-8792-8115  
Fax: 86-571-8792-8116

**China - Hong Kong SAR**  
Tel: 852-2943-5100  
Fax: 852-2401-3431

**China - Nanjing**  
Tel: 86-25-8473-2460  
Fax: 86-25-8473-2470

**China - Qingdao**  
Tel: 86-532-8502-7355  
Fax: 86-532-8502-7205

**China - Shanghai**  
Tel: 86-21-3326-8000  
Fax: 86-21-3326-8021

**China - Shenyang**  
Tel: 86-24-2334-2829  
Fax: 86-24-2334-2393

**China - Shenzhen**  
Tel: 86-755-8864-2200  
Fax: 86-755-8203-1760

**China - Wuhan**  
Tel: 86-27-5980-5300  
Fax: 86-27-5980-5118

**China - Xian**  
Tel: 86-29-8833-7252  
Fax: 86-29-8833-7256

### ASIA/PACIFIC

**China - Xiamen**  
Tel: 86-592-2388138  
Fax: 86-592-2388130

**China - Zhuhai**  
Tel: 86-756-3210040  
Fax: 86-756-3210049

**India - Bangalore**  
Tel: 91-80-3090-4444  
Fax: 91-80-3090-4123

**India - New Delhi**  
Tel: 91-11-4160-8631  
Fax: 91-11-4160-8632

**India - Pune**  
Tel: 91-20-3019-1500

**Japan - Osaka**  
Tel: 81-6-6152-7160  
Fax: 81-6-6152-9310

**Japan - Tokyo**  
Tel: 81-3-6880-3770  
Fax: 81-3-6880-3771

**Korea - Daegu**  
Tel: 82-53-744-4301  
Fax: 82-53-744-4302

**Korea - Seoul**  
Tel: 82-2-554-7200  
Fax: 82-2-558-5932 or  
82-2-558-5934

**Malaysia - Kuala Lumpur**  
Tel: 60-3-6201-9857  
Fax: 60-3-6201-9859

**Malaysia - Penang**  
Tel: 60-4-227-8870  
Fax: 60-4-227-4068

**Philippines - Manila**  
Tel: 63-2-634-9065  
Fax: 63-2-634-9069

**Singapore**  
Tel: 65-6334-8870  
Fax: 65-6334-8850

**Taiwan - Hsin Chu**  
Tel: 886-3-5778-366  
Fax: 886-3-5770-955

**Taiwan - Kaohsiung**  
Tel: 886-7-213-7830

**Taiwan - Taipei**  
Tel: 886-2-2508-8600  
Fax: 886-2-2508-0102

**Thailand - Bangkok**  
Tel: 66-2-694-1351  
Fax: 66-2-694-1350

### EUROPE

**Austria - Wels**  
Tel: 43-7242-2244-39  
Fax: 43-7242-2244-393

**Denmark - Copenhagen**  
Tel: 45-4450-2828  
Fax: 45-4485-2829

**Finland - Espoo**  
Tel: 358-9-4520-820

**France - Paris**  
Tel: 33-1-69-53-63-20  
Fax: 33-1-69-30-90-79

**France - Saint Cloud**  
Tel: 33-1-30-60-70-00

**Germany - Garching**  
Tel: 49-8931-9700

**Germany - Haan**  
Tel: 49-2129-3766400

**Germany - Heilbronn**  
Tel: 49-7131-67-3636

**Germany - Karlsruhe**  
Tel: 49-721-625370

**Germany - Munich**  
Tel: 49-89-627-144-0  
Fax: 49-89-627-144-44

**Germany - Rosenheim**  
Tel: 49-8031-354-560

**Israel - Ra'anana**  
Tel: 972-9-744-7705

**Italy - Milan**  
Tel: 39-0331-742611  
Fax: 39-0331-466781

**Italy - Padova**  
Tel: 39-049-7625286

**Netherlands - Drunen**  
Tel: 31-416-690399  
Fax: 31-416-690340

**Norway - Trondheim**  
Tel: 47-7289-7561

**Poland - Warsaw**  
Tel: 48-22-3325737

**Romania - Bucharest**  
Tel: 40-21-407-87-50

**Spain - Madrid**  
Tel: 34-91-708-08-90  
Fax: 34-91-708-08-91

**Sweden - Gothenberg**  
Tel: 46-31-704-60-40

**Sweden - Stockholm**  
Tel: 46-8-5090-4654

**UK - Wokingham**  
Tel: 44-118-921-5800  
Fax: 44-118-921-5820

## X-ON Electronics

Largest Supplier of Electrical and Electronic Components

*Click to view similar products for [Development Software](#) category:*

*Click to view products by [Microchip](#) manufacturer:*

Other Similar products are found below :

[SRP004001-01](#) [SW163052](#) [SYSWINEV21](#) [WS01NCTF1E](#) [W128E13](#) [SW89CN0-ZCC](#) [IP-UART-16550](#) [MPROG-PRO535E](#) [AFLCF-08-LX-CE060-R21](#) [WS02-CFSC1-EV3-UP](#) [SYSMAC-STUDIO-EIPCPLR](#) [LIB-PL-PC-N-1YR-DISKID](#) [1120270005](#) [MIKROBASIC PRO FOR FT90X \(USB DONGLE\)](#) [MIKROC PRO FOR FT90X \(USB DONGLE\)](#) [MIKROBASIC PRO FOR AVR \(USB DONGLE LICEN](#)  
[MIKROBASIC PRO FOR FT90X](#) [MIKROC PRO FOR DSPIC30/33 \(USB DONGLE LI](#) [MIKROPASCAL PRO FOR ARM \(USB DONGLE](#)  
[LICE](#) [MIKROPASCAL PRO FOR FT90X](#) [MIKROPASCAL PRO FOR FT90X \(USB DONGLE\)](#) [MIKROPASCAL PRO FOR PIC32 \(USB](#)  
[DONGLE LI](#) [SW006021-2H](#) [ATATMELSTUDIO](#) [2400573](#) [2702579](#) [2988609](#) [SW006022-DGL](#) [2400303](#) [88970111](#) [DG-ACC-NET-CD](#)  
[55195101-101](#) [55195101-102](#) [SW1A-W1C](#) [MDK-ARM](#) [SW006021-2NH](#) [SW006021-1H](#) [SW006021-2](#) [SW006022-2](#) [SW006023-2](#)  
[SW007023](#) [MIKROE-730](#) [MIKROE-2401](#) [MIKROE-499](#) [MIKROE-722](#) [MIKROE-724](#) [MIKROE-726](#) [MIKROE-728](#) [MIKROE-732](#)  
[MIKROE-734](#)