



**QUAD
DRIVER**

**SY10E112
SY100E112**

FEATURES

- 600ps max. propagation delay
- Extended 100E VEE range of -4.2V to -5.5V
- Common enable input
- Fully compatible with industry standard 10KH, 100K I/O levels
- Internal 75KΩ input pulldown resistors
- Fully compatible with Motorola MC10E/100E112
- Available in 28-pin PLCC package

DESCRIPTION

The SY10/100E112 are quad drivers designed for use in new, high-performance ECL systems. The E112 has two pairs of OR/NOR outputs from each gate and a common, buffered enable input. The data input can also be used as an ECL memory address fan-out driver, although the E111 is designed specifically for this purpose, and offers lower skew than the E112. For memory address driver applications where scan capabilities are required, please refer to the SY10/100E212 device.

BLOCK DIAGRAM

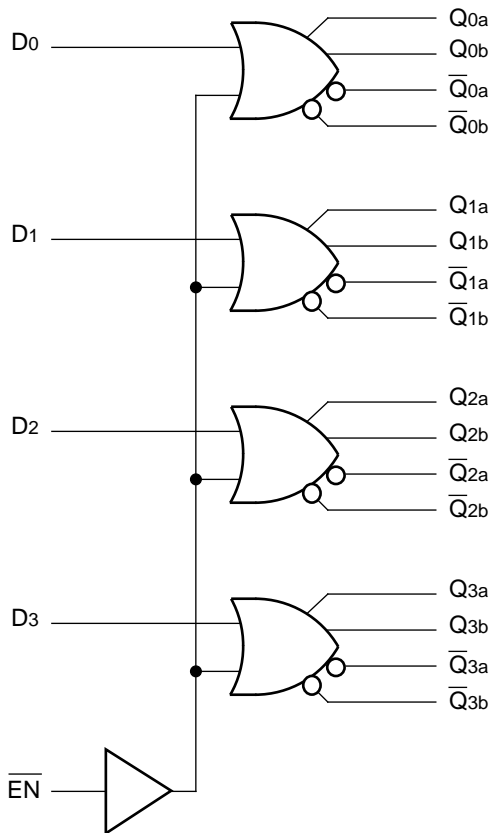

PIN NAMES

Pin	Function
D0-D3	Data Inputs
\overline{EN}	Enable Input
Qna, Qnb	True Outputs
$\overline{Qna}, \overline{Qnb}$	Inverting Outputs
VCCO	Vcc to Output

PACKAGE/ORDERING INFORMATION

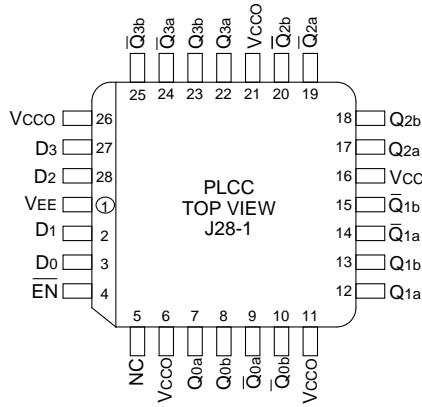

28-Pin PLCC (J28-1)

Ordering Information⁽¹⁾

Part Number	Package Type	Operating Range	Package Marking	Lead Finish
SY10E112JI	J28-1	Industrial	SY10E112JI	Sn-Pb
SY10E112JITR ⁽²⁾	J28-1	Industrial	SY10E112JI	Sn-Pb
SY100E112JI	J28-1	Industrial	SY100E112JI	Sn-Pb
SY100E112JITR ⁽²⁾	J28-1	Industrial	SY100E112JI	Sn-Pb
SY10E112JC	J28-1	Commercial	SY10E112JC	Sn-Pb
SY10E112JCTR ⁽²⁾	J28-1	Commercial	SY10E112JC	Sn-Pb
SY100E112JC	J28-1	Commercial	SY100E112JC	Sn-Pb
SY100E112JCTR ⁽²⁾	J28-1	Commercial	SY100E112JC	Sn-Pb
SY10E112JY ⁽³⁾	J28-1	Industrial	SY10E112JY with Pb-Free bar-line indicator	Matte-Sn
SY10E112JYTR ^(2, 3)	J28-1	Industrial	SY10E112JY with Pb-Free bar-line indicator	Matte-Sn
SY100E112JY ⁽³⁾	J28-1	Industrial	SY100E112JY with Pb-Free bar-line indicator	Matte-Sn
SY100E112JYTR ^(2, 3)	J28-1	Industrial	SY100E112JY with Pb-Free bar-line indicator	Matte-Sn

Notes:

1. Contact factory for die availability. Dice are guaranteed at T_A = 25°C, DC Electricals only.
2. Tape and Reel.
3. Pb-Free package is recommended for new designs.

TRUTH TABLE

\overline{EN}	Q_n	$\overline{Q_n}$
L	D_n	$\overline{D_n}$
H	H	L

DC ELECTRICAL CHARACTERISTICS

VEE = VEE (Min.) to VEE (Max.); VCC = VCCO = GND

Symbol	Parameter	TA = -40°C			TA = 0°C			TA = +25°C			TA = +85°C			Unit
		Min.	Typ.	Max.	Min.	Typ.	Max.	Min.	Typ.	Max.	Min.	Typ.	Max.	
IIH	Input HIGH Current	—	—	150	—	—	150	—	—	150	—	—	150	μA
	\overline{EN} D	—	—	200	—	—	200	—	—	200	—	—	200	
IEE	Power Supply Current	—	47	56	—	47	56	—	47	56	—	47	56	mA
	10E 100E	—	47	56	—	47	56	—	47	56	—	54	65	

AC ELECTRICAL CHARACTERISTICS

VEE = VEE (Min.) to VEE (Max.); VCC = VCCO = GND

Symbol	Parameter	TA = -40°C			TA = 0°C			TA = +25°C			TA = +85°C			Unit
		Min.	Typ.	Max.	Min.	Typ.	Max.	Min.	Typ.	Max.	Min.	Typ.	Max.	
tPD	Propagation Delay to Output	200	400	600	200	400	600	200	400	600	200	400	600	ps
	D \overline{EN}	275	450	675	275	450	675	275	450	675	275	450	675	
tskew	Within-Device Skew	—	80	—	—	80	—	—	80	—	—	80	—	ps
	D _n to Q _n , $\overline{Q_n}^{(1)}$ Q _{na} to Q _{nb} ⁽²⁾	—	40	—	—	40	—	—	40	—	—	40	—	
tr tf	Rise/Fall Time 20% to 80%	275	425	700	275	425	700	275	425	700	275	425	700	ps

Notes:

1. Within-device skew is defined as identical transitions on similar paths through a device.
2. Skew defined between common OR or common NOR outputs of a single gate.

28-PIN PLCC (J28-1)



Rev. 03

MICREL, INC. 2180 FORTUNE DRIVE SAN JOSE, CA 95131 USA

TEL + 1 (408) 944-0800 FAX + 1 (408) 474-1000 WEB <http://www.micrel.com>

The information furnished by Micrel in this data sheet is believed to be accurate and reliable. However, no responsibility is assumed by Micrel for its use. Micrel reserves the right to change circuitry and specifications at any time without notification to the customer.

Micrel Products are not designed or authorized for use as components in life support appliances, devices or systems where malfunction of a product can reasonably be expected to result in personal injury. Life support devices or systems are devices or systems that (a) are intended for surgical implant into the body or (b) support or sustain life, and whose failure to perform can be reasonably expected to result in a significant injury to the user. A Purchaser's use or sale of Micrel Products for use in life support appliances, devices or systems is at Purchaser's own risk and Purchaser agrees to fully indemnify Micrel for any damages resulting from such use or sale.

© 2006 Micrel, Incorporated.

X-ON Electronics

Largest Supplier of Electrical and Electronic Components

Click to view similar products for [Buffers & Line Drivers](#) category:

Click to view products by [Microchip](#) manufacturer:

Other Similar products are found below :

[LXV200-024SW](#) [74AUP2G34FW3-7](#) [HEF4043BP](#) [PI74FCT3244L](#) [MC74HCT365ADTR2G](#) [Le87401NQC](#) [Le87402MQC](#) [028192B](#)
[042140C](#) [051117G](#) [070519XB](#) [NL17SZ07P5T5G](#) [NLU1GT126AMUTCG](#) [74AUP1G17FW5-7](#) [74LVC2G17FW4-7](#) [CD4502BE](#) [5962-](#)
[8982101PA](#) [5962-9052201PA](#) [74LVC1G125FW4-7](#) [NL17SH17P5T5G](#) [NL17SH125P5T5G](#) [NLV37WZ07USG](#) [74VHC541FT\(BE\)](#)
[RHRXH162244K1](#) [74AUP1G34FW5-7](#) [74AUP1G07FW5-7](#) [74LVC1G126FW4-7](#) [74LVC2G126RA3-7](#) [NLX2G17CMUTCG](#)
[74LVCE1G125FZ4-7](#) [Le87501NQC](#) [74AUP1G126FW5-7](#) [TC74HC4050AP\(F\)](#) [74LVCE1G07FZ4-7](#) [NLX3G16DMUTCG](#)
[NLX2G06AMUTCG](#) [NLVVHC1G50DFT2G](#) [LE87100NQC](#) [LE87290YQC](#) [LE87290YQCT](#) [LE87511NQC](#) [LE87511NQCT](#) [LE87557NQC](#)
[LE87557NQCT](#) [LE87614MQC](#) [LE87614MQCT](#) [74AUP1G125FW5-7](#) [NLU2G16CMUTCG](#) [MC74LCX244MN2TWG](#) [NL17SG126DFT2G](#)