



**UNIVERSAL
DEMULTIPLEXER/
DECODER**

SY100S370

FEATURES

- Max. propagation delay of 1200ps
- IEE min. of -92mA
- Industry standard 100K ECL levels
- Extended supply voltage option:
VEE = -4.2V to -5.5V
- Voltage and temperature compensation for improved noise immunity
- Internal 75kΩ input pull-down resistors
- 60% faster than National or Signetics
- Approximately 40% lower power than Fairchild
- Function and pinout compatible with Fairchild F100K
- Available in 28-pin PLCC packages

DESCRIPTION

The SY100S370 is a universal demultiplexer/decoder that can be used as either a dual 1-of-4 decoder or as a single 1-of-8 decoder and is designed for use in high-performance ECL systems. The Mode control (M) input determines the function. In the dual 1-of-4 mode, each 4-input group has a pair of active-LOW Enable (\bar{E}) inputs. The Enable pins are assigned such that in the single 1-of-8 mode they can be tied together in pairs to result in two active-LOW Enable inputs. \bar{E}_{1a} will be tied to \bar{E}_{1b} and \bar{E}_{2a} to \bar{E}_{2b} .

The auxiliary inputs (H_n) are used to determine whether the outputs are active-HIGH or active-LOW. The address inputs for the dual 1-of-4 mode are A_{0a} , A_{1a} , A_{0b} . A_{2a} is unused. In the 1-of-8 mode, the address inputs are A_{0a} , A_{1a} , A_{2a} . The inputs on the device have 75kΩ pull-down resistors.

PIN NAMES

Pin	Function
A_{na} , A_{nb}	Address Inputs ($n = 0, 1, 2$)
\bar{E}_{na} , \bar{E}_{nb}	Enable Inputs ($n = 1, 2$)
M	Mode Control Input
H_a	$Z_0 - Z_3$ ($\bar{Z}_{0a} - \bar{Z}_{3a}$) Polarity Select Input
H_b	$Z_4 - Z_7$ ($\bar{Z}_{0b} - \bar{Z}_{3b}$) Polarity Select Input
H_c	Common Polarity Select Input
$Z_0 - Z_7$	Single 1-of-8 Data Outputs
Z_{na} , Z_{nb}	Dual 1-of-4 Data Outputs ($n = 1...4$)
VEES	VEE Substrate
VCCA	VCCO for ECL Outputs

PACKAGE/ORDERING INFORMATION

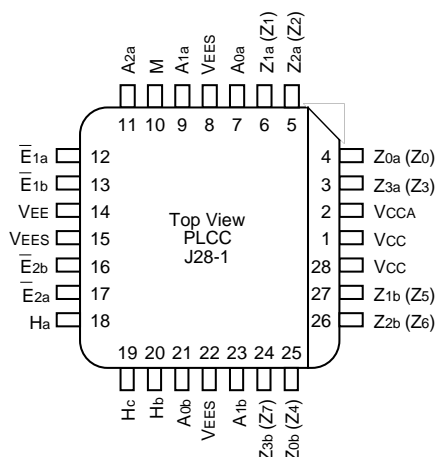

Ordering Information

Part Number	Package Type	Operating Range	Package Marking	Lead Finish
SY100S370JC	J28-1	Commercial	SY100S370JC	Sn-Pb
SY100S370JCTR ⁽¹⁾	J28-1	Commercial	SY100S370JC	Sn-Pb
SY100S370JZ ⁽²⁾	J28-1	Commercial	SY100S370JZ with Pb-Free bar-line indicator	Matte-Sn
SY100S370JZTR ^(1, 2)	J28-1	Commercial	SY100S370JZ with Pb-Free bar-line indicator	Matte-Sn

Notes:

1. Tape and Reel.
2. Pb-Free package is recommended for new designs.

28-Pin PLCC (J28-1)

TRUTH TABLES⁽¹⁾

Dual 1-of-4 Mode (M = A2a = Hc = LOW)												
Inputs				Active HIGH Outputs (Ha and Hb Inputs HIGH)				Active LOW Outputs (Ha and Hb Inputs LOW)				
$\bar{E}1a, \bar{E}1b$	$\bar{E}2a, \bar{E}2b$	A1a, A1b	A0a, A0b	Z0a, Z0b	Z1a, Z1b	Z2a, Z2b	Z3a, Z3b	Z0a, Z0b	Z1a, Z1b	Z2a, Z2b	Z3a, Z3b	
H	X	X	X	L	L	L	L	H	H	H	H	
X	H	X	X	L	L	L	L	H	H	H	H	
L	L	L	L	H	L	L	L	L	H	H	H	
L	L	L	H	L	H	L	L	H	L	H	H	
L	L	H	L	L	L	H	L	H	H	L	H	
L	L	H	H	L	L	L	H	H	H	H	L	

Single 1-of-8 Mode (M = HIGH; A0b = A1b = Ha = Hb = LOW)												
Inputs					Active HIGH Outputs* (Hc Input HIGH)							
$\bar{E}1$	$\bar{E}2$	A2a	A1a	A0a	Z0	Z1	Z2	Z3	Z4	Z5	Z6	Z7
H	X	X	X	X	L	L	L	L	L	L	L	L
X	H	X	X	X	L	L	L	L	L	L	L	L
L	L	L	L	L	H	L	L	L	L	L	L	L
L	L	L	L	H	L	H	L	L	L	L	L	L
L	L	L	H	L	L	L	H	L	L	L	L	L
L	L	L	H	H	L	L	L	H	L	L	L	L
L	L	H	L	L	L	L	L	L	H	L	L	L
L	L	H	L	H	L	L	L	L	L	H	L	L
L	L	H	H	L	L	L	L	L	L	L	H	L
L	L	H	H	H	L	L	L	L	L	L	L	H

Note:

1. H = HIGH Voltage Level
L = LOW Voltage Level
X = Don't Care
* for Hc = LOW, output states are complemented
 $\bar{E}1 = \bar{E}1a$ and $\bar{E}1b$ wired; $\bar{E}2 = \bar{E}2a$ and $\bar{E}2b$ wired

BLOCK DIAGRAM

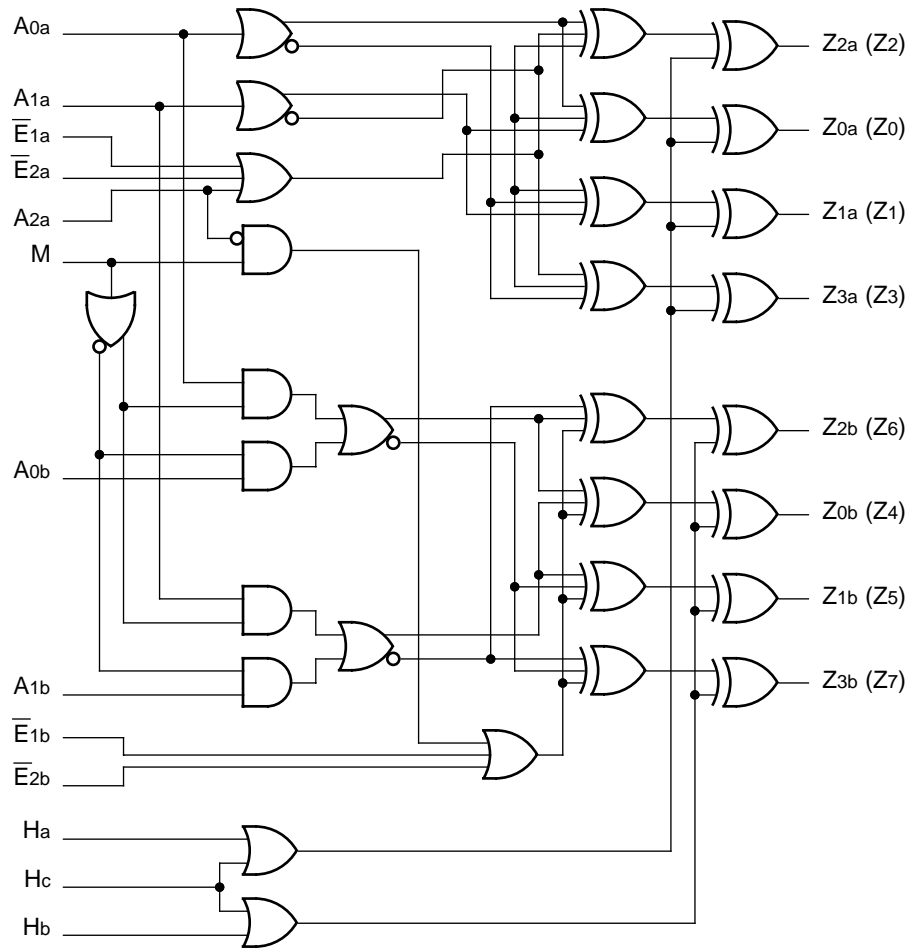

DC ELECTRICAL CHARACTERISTICS

$V_{EE} = -4.2V$ to $-5.5V$ unless otherwise specified; $V_{CC} = V_{CCA} = GND$

Symbol	Parameter	Min.	Typ.	Max.	Unit	Condition
I_{IH}	Input HIGH Current Hc, A0a, A1a, A2a All Others	— —	— —	310 250	μA	$V_{IN} = V_{IH} (Max.)$
I_{EE}	Power Supply Current	-92	-73	-46	mA	Inputs Open

AC ELECTRICAL CHARACTERISTICS

$V_{EE} = -4.2V$ to $-5.5V$ unless otherwise specified; $V_{CC} = V_{CCA} = GND$

Symbol	Parameter	$T_A = 0^{\circ}C$		$T_A = +25^{\circ}C$		$T_A = +85^{\circ}C$		Unit	Condition
		Min.	Max.	Min.	Max.	Min.	Max.		
t_{PLH} t_{PHL}	Propagation Delay $\bar{E}_{na}, \bar{E}_{nb}$ to Output	300	1200	300	1200	300	1200	ps	
t_{PLH} t_{PHL}	Propagation Delay A _{na} , A _{nb} to Output	500	1500	500	1500	500	1500	ps	
t_{PLH} t_{PHL}	Propagation Delay H _a , H _b , H _c to Output	500	1500	500	1500	500	1500	ps	
t_{PLH} t_{PHL}	Propagation Delay M to Output	600	2100	600	2100	600	2100	ps	
t_{TLH} t_{THL}	Transition Time 20% to 80%, 80% to 20%	300	900	300	900	300	900	ps	

TIMING DIAGRAM

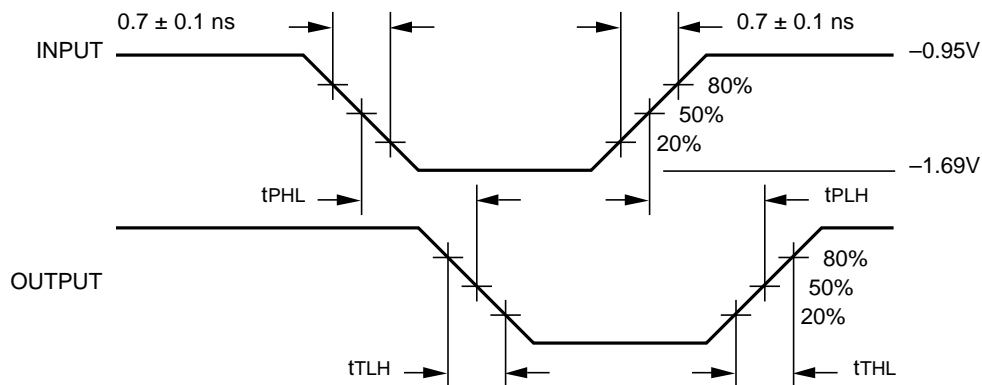

Propagation Delay and Transition Times

Note:

$V_{EE} = -4.2V$ to $-5.5V$ unless otherwise specified; $V_{CC} = V_{CCA} = GND$

28-PIN PLCC (J28-1)

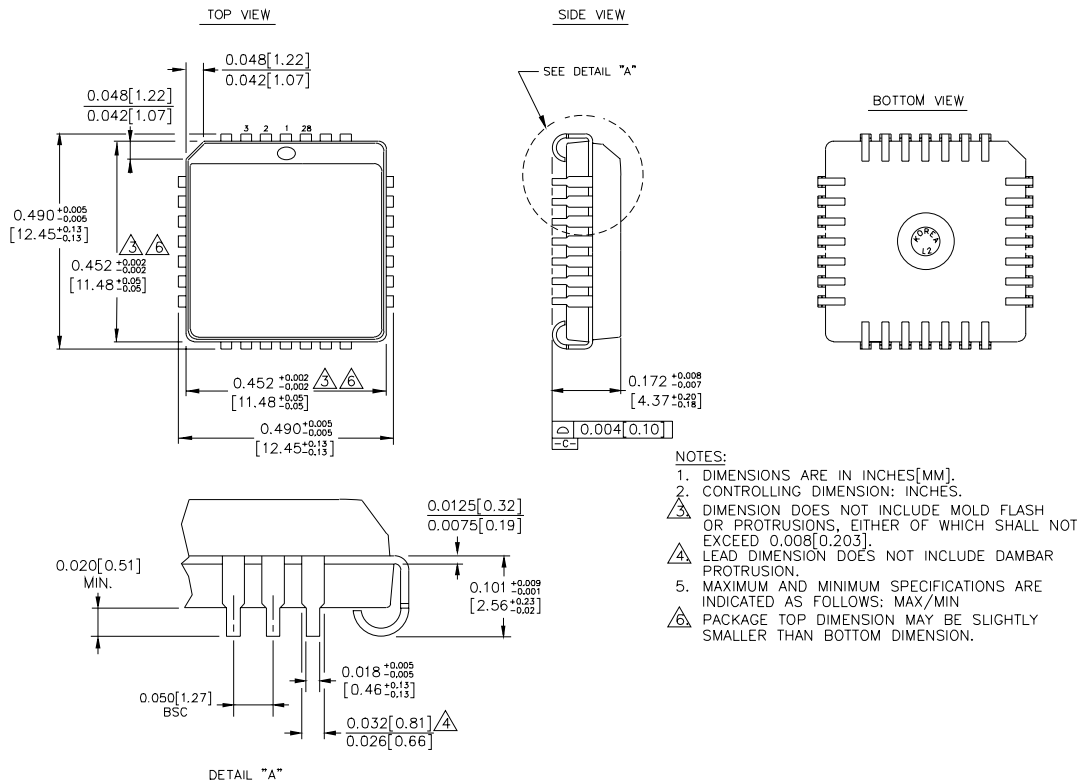

Rev. 03

MICREL, INC. 2180 FORTUNE DRIVE SAN JOSE, CA 95131 USA

TEL + 1 (408) 944-0800 FAX + 1 (408) 474-1000 WEB <http://www.micrel.com>

The information furnished by Micrel in this datasheet is believed to be accurate and reliable. However, no responsibility is assumed by Micrel for its use. Micrel reserves the right to change circuitry and specifications at any time without notification to the customer.

Micrel Products are not designed or authorized for use as components in life support appliances, devices or systems where malfunction of a product can reasonably be expected to result in personal injury. Life support devices or systems are devices or systems that (a) are intended for surgical implant into the body or (b) support or sustain life, and whose failure to perform can be reasonably expected to result in a significant injury to the user. A Purchaser's use or sale of Micrel Products for use in life support appliances, devices or systems is at Purchaser's own risk and Purchaser agrees to fully indemnify Micrel for any damages resulting from such use or sale.

© 2006 Micrel, Incorporated.

X-ON Electronics

Largest Supplier of Electrical and Electronic Components

Click to view similar products for [Encoders, Decoders, Multiplexers & Demultiplexers](#) *category:*

Click to view products by [Microchip](#) *manufacturer:*

Other Similar products are found below :

[MC74HC163ADTG](#) [74HC253N](#) [NLV74VHC1G01DFT1G](#) [TC74AC138P\(F\)](#) [NLV14051BDR2G](#) [NLV74HC238ADTR2G](#) [COMX-CAR-210](#)
[5962-8607001EA](#) [NTE74LS247](#) [5962-8756601EA](#) [8CA3052APGGI8](#) [TC74VHC138F\(EL,K,F\)](#) [PI3B3251LE](#) [PI3B3251QE](#) [NTE4028B](#)
[NTE4514B](#) [NTE4515B](#) [NTE4543B](#) [NTE4547B](#) [NTE74LS249](#) [NLV74HC4851AMNTWG](#) [MC74LVX257DG](#) [M74HCT4851ADWR2G](#)
[AP4373AW5-7-01](#) [MC74LVX257DTR2G](#) [74VHC4066AFT\(BJ\)](#) [74VHCT138AFT\(BJ\)](#) [74HC158D.652](#) [74HC4052D\(BJ\)](#) [74VHC138MTC](#)
[COMX-CAR-P1](#) [JM38510/65852BEA](#) [JM38510/30702BEA](#) [74VHC138MTCX](#) [74HC138D\(BJ\)](#) [NL7SZ19DFT2G](#) [74AHCT138T16-13](#)
[74LCX138FT\(AJ\)](#) [74LCX157FT\(AJ\)](#) [NL7SZ18MUR2G](#) [PCA9540BD,118](#) [QS3VH16233PAG8](#) [SNJ54HC251J](#) [SN54LS139AJ](#)
[SN74CBTLV3257PWG4](#) [SN74ALS156DR](#) [SN74AHCT139PWR](#) [74HC251D.652](#) [74HC257D.652](#) [74HCT153D.652](#)