

## 5V/3.3V ECL Differential Receiver

### Features

- 3.3V and 5V Power Supply Options
- 250 ps Propagation Delay (Typical)
- High Bandwidth Output Transitions
- Internal 75 k $\Omega$  Input Pull-Down Resistors
- Available in 8-pin (3 mm x 3 mm) MSOP and SOIC Packages

### General Description

The SY100EL16V is a differential receiver. With fast output transition times, the SY100EL16V is ideally suited for interfacing with high-frequency sources.

The SY100EL16V provides a VBB output for either single-ended use or as a DC bias for AC coupling to the device. The VBB pin should be used only as a bias for the SY100EL16V as its current sink/source capability is limited. Whenever used, the VBB pin should be bypassed to ground via a 0.01  $\mu$ F capacitor.

Under open input conditions (pulled to VEE), internal input clamps will force the Q output low.

### Package Type

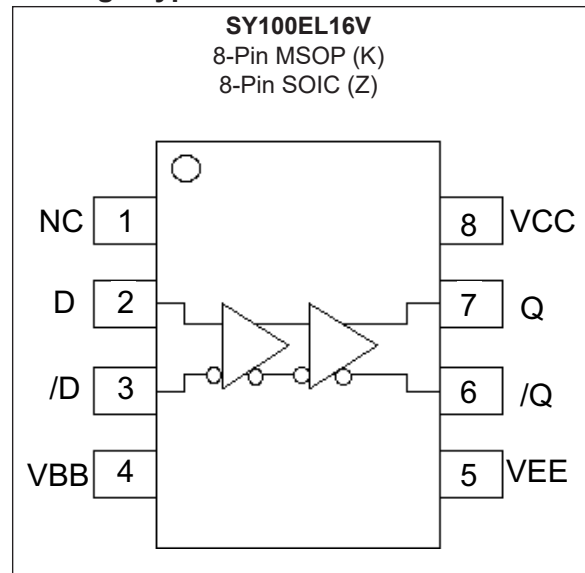

# SY100EL16V

## 1.0 ELECTRICAL CHARACTERISTICS

### Absolute Maximum Ratings †

PECL Power Supply Voltage ( $V_{CC}$ ) (Note 1)	+8V
NECL Power Supply Voltage ( $V_{EE}$ ) (Note 2)	-8V
PECL Mode Input Voltage ( $V_{IN}$ ) (Note 3)	+6V
NECL Mode Input Voltage ( $V_{IN}$ ) (Note 4)	-6V
Continuous Output Current ( $I_{OUT}$ )	50 mA
Surge Output Current ( $I_{OUT}$ )	100 mA
ESD Rating (Note 5)	>2 kV

† **Notice:** Stresses above those listed under “Absolute Maximum ratings” may cause permanent damage to the device. Exposure to maximum rating conditions for extended periods may affect device reliability.

- Note 1:**  $V_{EE} = 0V$   
**2:**  $V_{CC} = 0V$   
**3:**  $V_{EE} = 0V, V_{IN} \leq V_{CC}$   
**4:**  $V_{CC} = 0V, V_{IN} \geq V_{EE}$   
**5:** Mil Std. 883 Human Body Model, all pins

### PECL DC ELECTRICAL CHARACTERISTICS

**Electrical Specifications PECL:**  $V_{CC} = 3.0V$  to  $5.5V$ ;  $V_{EE} = 0V$ ;  $T_A = -40^\circ C$  to  $+85^\circ C$ , unless otherwise stated (Note 1)

Parameter	Symbol	Min.	Typ.	Max.	Units	Conditions
Power Supply Current	$I_{EE}$	—	18	22	mA	$T_A = -40^\circ C$ to $+25^\circ C$
		—	21	26		$T_A = +85^\circ C$
Output High Voltage (Note 2)	$V_{OH}$	$V_{CC} - 1.085$	$V_{CC} - 1.005$	$V_{CC} - 0.88$	V	$T_A = -40^\circ C$
		$V_{CC} - 1.025$	$V_{CC} - 0.955$	$V_{CC} - 0.88$		$T_A = 0^\circ C$ to $+85^\circ C$
Output Low Voltage (Note 2)	$V_{OL}$	$V_{CC} - 1.830$	$V_{CC} - 1.695$	$V_{CC} - 1.555$	V	$T_A = -40^\circ C$
		$V_{CC} - 1.810$	$V_{CC} - 1.705$	$V_{CC} - 1.620$		$T_A = 0^\circ C$ to $+85^\circ C$
Input High Voltage (Single-Ended)	$V_{IH}$	$V_{CC} - 1.165$	—	$V_{CC} - 0.880$	V	—
Input Low Voltage (Single-Ended)	$V_{IL}$	$V_{CC} - 1.810$	—	$V_{CC} - 1.475$	V	—
Output Reference Voltage	$V_{BB}$	$V_{CC} - 1.38$	—	$V_{CC} - 1.26$	V	—
Common Mode Range (Note 3)	$V_{IHCMR}$	2.0	—	$V_{CC} - 0.4$	V	$T_A = -40^\circ C$
		1.9	—	$V_{CC} - 0.4$		$T_A = 0^\circ C$ to $+85^\circ C$
Input High Current	$I_{IH}$	—	—	150	$\mu A$	—
Input Low Current	$I_{IL}$	0.5	—	—	$\mu A$	$V_{IN} = V_{IL(MIN)}$

- Note 1:** Devices are designed to meet the DC specifications shown in the above table after thermal equilibration has been established. The circuit is in a test socket or mounted on a printed circuit board and transverse airflow greater than 500 lpm is maintained.
- 2:** Outputs are terminated through a  $50\Omega$  resistor to  $V_{CC} - 2.0V$ .
- 3:** The CMR range is referenced to the most positive side of the differential input voltage. Normal operation is obtained if the high level falls within the specified range and the peak-to-peak voltage lies between 150 mV and 1V.

## NECL DC ELECTRICAL CHARACTERISTICS

**Electrical Specifications NECL:**  $V_{EE} = -5.5V$  to  $-3.0V$ ;  $V_{CC} = 0V$ ;  $T_A = -40^{\circ}C$  to  $+85^{\circ}C$ , unless otherwise stated (Note 1)

Parameter	Symbol	Min.	Typ.	Max.	Units	Conditions
Power Supply Current	$I_{EE}$	—	18	22	mA	$T_A = -40^{\circ}C$ to $+25^{\circ}C$
		—	21	26		$T_A = +85^{\circ}C$
Output High Voltage (Note 2)	$V_{OH}$	-1.085	-1.005	-0.88	V	$T_A = -40^{\circ}C$
		-1.025	-0.955	-0.88		$T_A = 0^{\circ}C$ to $+85^{\circ}C$
Output Low Voltage (Note 2)	$V_{OL}$	-1.830	-1.695	-1.555	V	$T_A = -40^{\circ}C$
		-1.810	-1.705	-1.620		$T_A = 0^{\circ}C$ to $+85^{\circ}C$
Input High Voltage (Single-Ended)	$V_{IH}$	-1.165	—	-0.880	V	—
Input Low Voltage (Single-Ended)	$V_{IL}$	-1.810	—	-1.475	V	—
Output Reference Voltage	$V_{BB}$	-1.38	—	-1.26	V	—
Common Mode Range (Note 3)	$V_{IHCMR}$	$V_{EE} + 2.0$	—	-0.4	V	$T_A = -40^{\circ}C$
		$V_{EE} + 1.9$	—	-0.4		$T_A = 0^{\circ}C$ to $+85^{\circ}C$
Input High Current	$I_{IH}$	—	—	150	$\mu A$	—
Input Low Current	$I_{IL}$	0.5	—	—	$\mu A$	$V_{IN} = V_{IL(MIN)}$

- Note 1:** Devices are designed to meet the DC specifications shown in the above table after thermal equilibration has been established. The circuit is in a test socket or mounted on a printed circuit board and transverse airflow greater than 500 lpm is maintained.
- 2:** Outputs are terminated through a  $50\Omega$  resistor to  $V_{CC}-2.0V$ .
- 3:** The CMR range is referenced to the most positive side of the differential input voltage. Normal operation is obtained if the high level falls within the specified range and the peak-to-peak voltage lies between 150 mV and 1V.

## AC ELECTRICAL CHARACTERISTICS

**Electrical Characteristics:**  $V_{CC} = 3.0V$  to  $5.5V$ ;  $V_{EE} = 0V$  or  $V_{EE} = -5.5V$  to  $-3.0V$ ;  $V_{CC} = 0V$ ;  $T_A = -40^{\circ}C$  to  $+85^{\circ}C$ , unless otherwise stated, (Note 1)

Parameter	Symbol	Min.	Typ.	Max.	Units	Conditions
Propagation Delay D to Q D (Differential)	$t_{PLH}$ $t_{PHL}$	125	250	375	ps	$T_A = -40^{\circ}C$
		175	250	325		$T_A = 0^{\circ}C, +25^{\circ}C$
		205	280	355		$T_A = +85^{\circ}C$
Propagation Delay D to Q (Single-Ended)	$t_{PLH}$ $t_{PHL}$	75	250	425	ps	$T_A = -40^{\circ}C$
		125	250	375		$T_A = 0^{\circ}C, +25^{\circ}C$
		155	280	405		$T_A = +85^{\circ}C$
Duty Cycle Skew (Note 2)	$t_{SKEW}$	—	5	—	ps	$T_A = -40^{\circ}C$
		—	5	20		$T_A = 0^{\circ}C$ to $+85^{\circ}C$
Input Swing (Note 3)	$V_{PP}$	150	—	1000	mV	—
Output Rise/Fall Time Q (20% to 80%)	$t_r/t_f$	100	225	350	ps	—

- Note 1:** Specification for packaged product only.
- 2:** Duty cycle skew is the difference between a  $t_{PLH}$  and  $t_{PHL}$  propagation delay through a device.
- 3:** Input swing for which AC parameters are ensured. The device has a DC gain of  $\approx 40$ .

# SY100EL16V

## TEMPERATURE SPECIFICATIONS

Parameters	Sym.	Min.	Typ.	Max.	Units	Conditions
<b>Temperature Ranges</b>						
Operating Temperature Range	$T_A$	-40	—	+85	°C	—
Storage Temperature Range	$T_S$	-65	—	+150	°C	—
Lead Temperature	$T_{LEAD}$	—	—	+260	°C	Soldering, 20 sec.
<b>Thermal Resistance</b>						
Package Thermal Resistance, SOIC 8-Ld	$\theta_{JA}$	—	160	—	°C/W	Still-Air
		—	109	—		500 lfpm
	$\theta_{JC}$	—	39	—	°C/W	—
	Package Thermal Resistance, MSOP 8-Ld	$\theta_{JA}$	—	206	—	°C/W
—			155	—	500 lfpm	
	$\theta_{JC}$	—	39	—	°C/W	—

## 2.0 PIN DESCRIPTIONS

The descriptions of the pins are listed in [Table 2-1](#).

**TABLE 2-1: PIN FUNCTION TABLE**

Pin Name	Description
D	Data Input
Q	Data Output
VBB	Reference Voltage Output
NC	Not Connected
VCC	Positive Power Supply
VEE	Negative Power Supply

# SY100EL16V

## 3.0 PACKAGING INFORMATION

### 3.1 Package Marking Information

8-Lead MSOP\*



Example



8-Lead SOIC\*



Example



**Legend:**  $XX...X$  Product code or customer-specific information  
Y Year code (last digit of calendar year)  
YY Year code (last 2 digits of calendar year)  
WW Week code (week of January 1 is week '01')  
NNN Alphanumeric traceability code  
 $\textcircled{e3}$  Pb-free JEDEC<sup>®</sup> designator for Matte Tin (Sn)  
\* This package is Pb-free. The Pb-free JEDEC designator ( $\textcircled{e3}$ ) can be found on the outer packaging for this package.  
 $\bullet$ ,  $\blacktriangle$ ,  $\blacktriangledown$  Pin one index is identified by a dot, delta up, or delta down (triangle mark).

**Note:** In the event the full Microchip part number cannot be marked on one line, it will be carried over to the next line, thus limiting the number of available characters for customer-specific information. Package may or may not include the corporate logo.  
Underbar ( $\bar{\quad}$ ) and/or Overbar ( $\bar{\quad}$ ) symbol may not be to scale.

## 8-Lead SOIC Package Outline and Recommended Land Pattern

**TITLE**

8 LEAD SOICN PACKAGE OUTLINE & RECOMMENDED LAND PATTERN

DRAWING #	SOICN-8LD-PL-1	UNIT	INCH [MM]
-----------	----------------	------	-----------

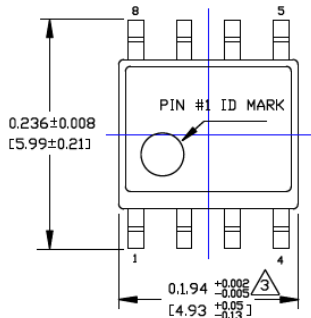

TOP VIEW

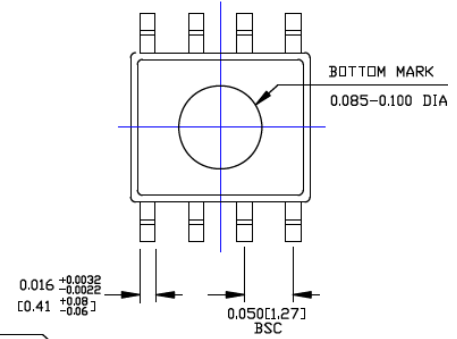

BOTTOM VIEW

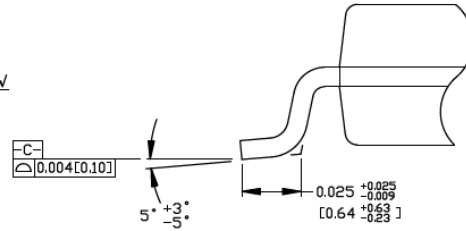

DETAIL "A"

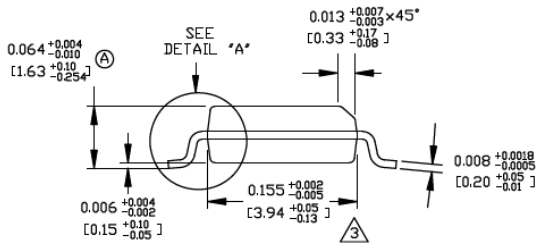

END VIEW

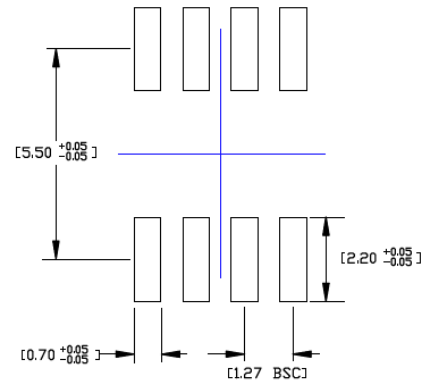

RECOMMENDED LAND PATTERN

**NOTES:**

1. DIMENSIONS ARE IN INCHES[MM].
2. CONTROLLING DIMENSION: INCHES.
3. DIMENSION DOES NOT INCLUDE MOLD FLASH OR PROTRUSIONS, EITHER OF WHICH SHALL NOT EXCEED 0.010[0.25] PER SIDE.

Note: For the most current package drawings, please see the Microchip Packaging Specification located at <http://www.microchip.com/packaging>.

# SY100EL16V

## 8-Lead MSOP Package Outline and Recommended Land Pattern

**TITLE**

8 LEAD MSOP PACKAGE OUTLINE & RECOMMENDED LAND PATTERN

DRAWING #	MSOP-8LD-PL-1	UNIT	INCH [MM]
-----------	---------------	------	-----------

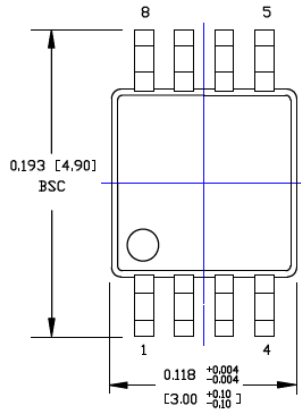

TOP VIEW

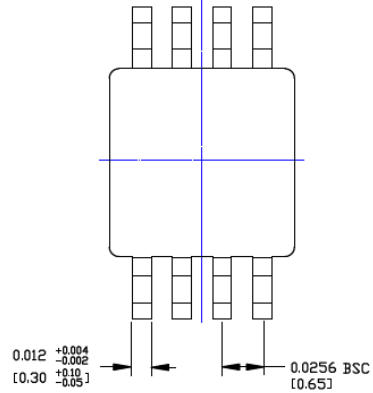

BOTTOM VIEW

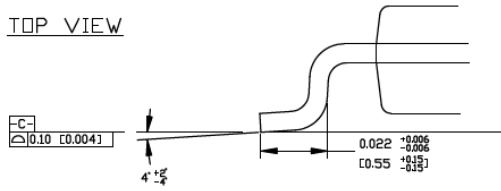

DETAIL A

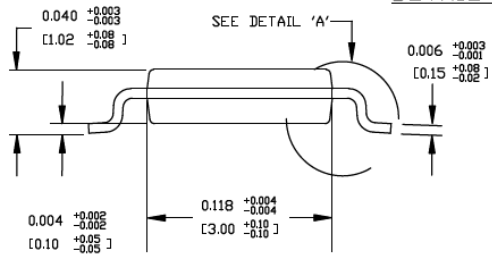

SIDE VIEW

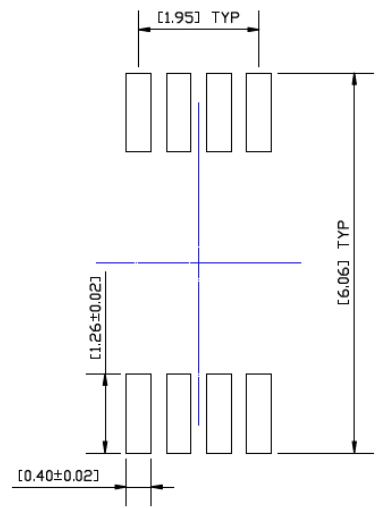

RECOMMENDED LAND PATTERN

- NOTES:
1. DIMENSIONS ARE IN INCHES [MM].
  2. CONTROLLING DIMENSION: MM
  3. DIMENSION DOES NOT INCLUDE MOLD FLASH OR PROTRUSIONS, EITHER OF WHICH SHALL NOT EXCEED 0.008 [0.20] PER SIDE.

Note: For the most current package drawings, please see the Microchip Packaging Specification located at <http://www.microchip.com/packaging>.



## APPENDIX A: REVISION HISTORY

### Revision A (November 2018)

- Converted Micrel document SY100EL16V to Microchip data sheet template DS20006115A.
- Made minor text changes throughout the document.
- Removed all reference to the EOL SY10EL16V version.

### Revision B (January 2020)

- Updated minimum values for Common Mode Range voltage in [PECL DC Electrical Characteristics](#) table and [NECL DC Electrical Characteristics](#) table.
- Minor stylistic updates to align data sheet with current style.
- Added Marking Spec for MSOP Package Option in **Section 3.1 “Package Marking Information”**.
- Added MSOP examples to the [Product Identification System](#) section.

# SY100EL16V

---

NOTES:

## PRODUCT IDENTIFICATION SYSTEM

To order or obtain information, e.g., on pricing or delivery, contact your local Microchip representative or sales office.

<u>PART NO.</u>	X	X	X	-XX	
Device	Supply Voltage	Package	Temperature Range	Special Processing	
<b>Device:</b>	SY100EL16: 5V/3.3V ECL Differential Receiver				
<b>Supply Voltage Range:</b>	V	=	3.3V/5V		
<b>Package:</b>	Z	=	8-Lead SOIC (Pb-Free NiPdAu)		
	K	=	8-Lead MSOP (Pb-Free NiPdAu)		
<b>Temperature Range:</b>	G	=	-40°C to +85°C		
<b>Special Processing:</b>	<blank>	=	95/Tube		
	TR	=	1,000/Reel		
					<b>Examples:</b>
					a) SY100EL16VZG: SY100EL16, 3.3V/5V, 8-Lead SOIC (Pb-Free NiPdAu), -40°C to +85°C, 95/Tube
					b) SY100EL16VZG-TR: SY100EL16, 3.3V/5V, 8-Lead SOIC (Pb-Free NiPdAu), -40°C to +85°C, 1,000/Reel
					c) SY100EL16VKG: SY100EL16, 3.3V/5V, 8-Lead MSOP (Pb-Free NiPdAu), -40°C to +85°C, 95/Tube
					d) SY100EL16VKG-TR: SY100EL16, 3.3V/5V, 8-Lead MSOP (Pb-Free NiPdAu), -40°C to +85°C, 1,000/Reel
					<b>Note 1:</b> Tape and Reel identifier only appears in the catalog part number description. This identifier is used for ordering purposes and is not printed on the device package. Check with your Microchip Sales Office for package availability with the Tape and Reel option.

# SY100EL16V

---

NOTES:

---

**Note the following details of the code protection feature on Microchip devices:**

- Microchip products meet the specification contained in their particular Microchip Data Sheet.
- Microchip believes that its family of products is one of the most secure families of its kind on the market today, when used in the intended manner and under normal conditions.
- There are dishonest and possibly illegal methods used to breach the code protection feature. All of these methods, to our knowledge, require using the Microchip products in a manner outside the operating specifications contained in Microchip's Data Sheets. Most likely, the person doing so is engaged in theft of intellectual property.
- Microchip is willing to work with the customer who is concerned about the integrity of their code.
- Neither Microchip nor any other semiconductor manufacturer can guarantee the security of their code. Code protection does not mean that we are guaranteeing the product as “unbreakable.”

Code protection is constantly evolving. We at Microchip are committed to continuously improving the code protection features of our products. Attempts to break Microchip's code protection feature may be a violation of the Digital Millennium Copyright Act. If such acts allow unauthorized access to your software or other copyrighted work, you may have a right to sue for relief under that Act.

---

Information contained in this publication regarding device applications and the like is provided only for your convenience and may be superseded by updates. It is your responsibility to ensure that your application meets with your specifications. MICROCHIP MAKES NO REPRESENTATIONS OR WARRANTIES OF ANY KIND WHETHER EXPRESS OR IMPLIED, WRITTEN OR ORAL, STATUTORY OR OTHERWISE, RELATED TO THE INFORMATION, INCLUDING BUT NOT LIMITED TO ITS CONDITION, QUALITY, PERFORMANCE, MERCHANTABILITY OR FITNESS FOR PURPOSE. Microchip disclaims all liability arising from this information and its use. Use of Microchip devices in life support and/or safety applications is entirely at the buyer's risk, and the buyer agrees to defend, indemnify and hold harmless Microchip from any and all damages, claims, suits, or expenses resulting from such use. No licenses are conveyed, implicitly or otherwise, under any Microchip intellectual property rights unless otherwise stated.

### Trademarks

The Microchip name and logo, the Microchip logo, Adaptec, AnyRate, AVR, AVR logo, AVR Freaks, BesTime, BitCloud, chipKIT, chipKIT logo, CryptoMemory, CryptoRF, dsPIC, FlashFlex, flexPWR, HELDO, IGLOO, JukeBlox, KeeLoq, Klear, LANCheck, LinkMD, maXStylus, maXTouch, MediaLB, megaAVR, Microsemi, Microsemi logo, MOST, MOST logo, MPLAB, OptoLyzer, PackeTime, PIC, picoPower, PICSTART, PIC32 logo, PolarFire, Prochip Designer, QTouch, SAM-BA, SenGenuity, SpyNIC, SST, SST Logo, SuperFlash, Symmetricom, SyncServer, Tachyon, TempTracker, TimeSource, tinyAVR, UNI/O, Vectron, and XMEGA are registered trademarks of Microchip Technology Incorporated in the U.S.A. and other countries.

APT, ClockWorks, The Embedded Control Solutions Company, EtherSynch, FlashTec, Hyper Speed Control, HyperLight Load, IntelliMOS, Libero, motorBench, mTouch, Powermite 3, Precision Edge, ProASIC, ProASIC Plus, ProASIC Plus logo, Quiet-Wire, SmartFusion, SyncWorld, Temux, TimeCesium, TimeHub, TimePictra, TimeProvider, Vite, WinPath, and ZL are registered trademarks of Microchip Technology Incorporated in the U.S.A.

Adjacent Key Suppression, AKS, Analog-for-the-Digital Age, Any Capacitor, AnyIn, AnyOut, BlueSky, BodyCom, CodeGuard, CryptoAuthentication, CryptoAutomotive, CryptoCompanion, CryptoController, dsPICDEM, dsPICDEM.net, Dynamic Average Matching, DAM, ECAN, EtherGREEN, In-Circuit Serial Programming, ICSP, INICnet, Inter-Chip Connectivity, JitterBlocker, KlearNet, KlearNet logo, memBrain, Mindi, MiWi, MPASM, MPF, MPLAB Certified logo, MPLIB, MPLINK, MultiTRAK, NetDetach, Omniscient Code Generation, PICDEM, PICDEM.net, PICKit, PICtail, PowerSmart, PureSilicon, QMatrix, REAL ICE, Ripple Blocker, SAM-ICE, Serial Quad I/O, SMART-I.S., SQI, SuperSwitcher, SuperSwitcher II, Total Endurance, TSHARC, USBCheck, VariSense, ViewSpan, WiperLock, Wireless DNA, and ZENA are trademarks of Microchip Technology Incorporated in the U.S.A. and other countries.

SQTP is a service mark of Microchip Technology Incorporated in the U.S.A.

The Adaptec logo, Frequency on Demand, Silicon Storage Technology, and Symmcom are registered trademarks of Microchip Technology Inc. in other countries.

GestIC is a registered trademark of Microchip Technology Germany II GmbH & Co. KG, a subsidiary of Microchip Technology Inc., in other countries.

All other trademarks mentioned herein are property of their respective companies.

© 2018-2020, Microchip Technology Incorporated, All Rights Reserved.

ISBN: 978-1-5224-5531-8

For information regarding Microchip's Quality Management Systems, please visit [www.microchip.com/quality](http://www.microchip.com/quality).



# MICROCHIP

## Worldwide Sales and Service

### AMERICAS

**Corporate Office**  
2355 West Chandler Blvd.  
Chandler, AZ 85224-6199  
Tel: 480-792-7200  
Fax: 480-792-7277  
Technical Support:  
<http://www.microchip.com/support>  
Web Address:  
[www.microchip.com](http://www.microchip.com)

#### Atlanta

Duluth, GA  
Tel: 678-957-9614  
Fax: 678-957-1455

#### Austin, TX

Tel: 512-257-3370

#### Boston

Westborough, MA  
Tel: 774-760-0087  
Fax: 774-760-0088

#### Chicago

Itasca, IL  
Tel: 630-285-0071  
Fax: 630-285-0075

#### Dallas

Addison, TX  
Tel: 972-818-7423  
Fax: 972-818-2924

#### Detroit

Novi, MI  
Tel: 248-848-4000

#### Houston, TX

Tel: 281-894-5983

#### Indianapolis

Noblesville, IN  
Tel: 317-773-8323  
Fax: 317-773-5453  
Tel: 317-536-2380

#### Los Angeles

Mission Viejo, CA  
Tel: 949-462-9523  
Fax: 949-462-9608  
Tel: 951-273-7800

#### Raleigh, NC

Tel: 919-844-7510

#### New York, NY

Tel: 631-435-6000

#### San Jose, CA

Tel: 408-735-9110  
Tel: 408-436-4270

#### Canada - Toronto

Tel: 905-695-1980  
Fax: 905-695-2078

### ASIA/PACIFIC

**Australia - Sydney**  
Tel: 61-2-9868-6733

**China - Beijing**  
Tel: 86-10-8569-7000

**China - Chengdu**  
Tel: 86-28-8665-5511

**China - Chongqing**  
Tel: 86-23-8980-9588

**China - Dongguan**  
Tel: 86-769-8702-9880

**China - Guangzhou**  
Tel: 86-20-8755-8029

**China - Hangzhou**  
Tel: 86-571-8792-8115

**China - Hong Kong SAR**  
Tel: 852-2943-5100

**China - Nanjing**  
Tel: 86-25-8473-2460

**China - Qingdao**  
Tel: 86-532-8502-7355

**China - Shanghai**  
Tel: 86-21-3326-8000

**China - Shenyang**  
Tel: 86-24-2334-2829

**China - Shenzhen**  
Tel: 86-755-8864-2200

**China - Suzhou**  
Tel: 86-186-6233-1526

**China - Wuhan**  
Tel: 86-27-5980-5300

**China - Xian**  
Tel: 86-29-8833-7252

**China - Xiamen**  
Tel: 86-592-2388138

**China - Zhuhai**  
Tel: 86-756-3210040

### ASIA/PACIFIC

**India - Bangalore**  
Tel: 91-80-3090-4444

**India - New Delhi**  
Tel: 91-11-4160-8631

**India - Pune**  
Tel: 91-20-4121-0141

**Japan - Osaka**  
Tel: 81-6-6152-7160

**Japan - Tokyo**  
Tel: 81-3-6880-3770

**Korea - Daegu**  
Tel: 82-53-744-4301

**Korea - Seoul**  
Tel: 82-2-554-7200

**Malaysia - Kuala Lumpur**  
Tel: 60-3-7651-7906

**Malaysia - Penang**  
Tel: 60-4-227-8870

**Philippines - Manila**  
Tel: 63-2-634-9065

**Singapore**  
Tel: 65-6334-8870

**Taiwan - Hsin Chu**  
Tel: 886-3-577-8366

**Taiwan - Kaohsiung**  
Tel: 886-7-213-7830

**Taiwan - Taipei**  
Tel: 886-2-2508-8600

**Thailand - Bangkok**  
Tel: 66-2-694-1351

**Vietnam - Ho Chi Minh**  
Tel: 84-28-5448-2100

### EUROPE

**Austria - Wels**  
Tel: 43-7242-2244-39  
Fax: 43-7242-2244-393

**Denmark - Copenhagen**  
Tel: 45-4450-2828  
Fax: 45-4485-2829

**Finland - Espoo**  
Tel: 358-9-4520-820

**France - Paris**  
Tel: 33-1-69-53-63-20  
Fax: 33-1-69-30-90-79

**Germany - Garching**  
Tel: 49-8931-9700

**Germany - Haan**  
Tel: 49-2129-3766400

**Germany - Heilbronn**  
Tel: 49-7131-72400

**Germany - Karlsruhe**  
Tel: 49-721-625370

**Germany - Munich**  
Tel: 49-89-627-144-0  
Fax: 49-89-627-144-44

**Germany - Rosenheim**  
Tel: 49-8031-354-560

**Israel - Ra'anana**  
Tel: 972-9-744-7705

**Italy - Milan**  
Tel: 39-0331-742611  
Fax: 39-0331-466781

**Italy - Padova**  
Tel: 39-049-7625286

**Netherlands - Drunen**  
Tel: 31-416-690399  
Fax: 31-416-690340

**Norway - Trondheim**  
Tel: 47-7288-4388

**Poland - Warsaw**  
Tel: 48-22-3325737

**Romania - Bucharest**  
Tel: 40-21-407-87-50

**Spain - Madrid**  
Tel: 34-91-708-08-90  
Fax: 34-91-708-08-91

**Sweden - Gothenberg**  
Tel: 46-31-704-60-40

**Sweden - Stockholm**  
Tel: 46-8-5090-4654

**UK - Wokingham**  
Tel: 44-118-921-5800  
Fax: 44-118-921-5820

## X-ON Electronics

Largest Supplier of Electrical and Electronic Components

*Click to view similar products for [Buffers & Line Drivers](#) category:*

*Click to view products by [Microchip](#) manufacturer:*

Other Similar products are found below :

[5962-9217601MSA](#) [634810D](#) [HEF4043BP](#) [NL17SG125DFT2G](#) [NL17SZ126P5T5G](#) [NLU1GT126CMUTCG](#) [NLU3G16AMX1TCG](#)  
[NLV27WZ125USG](#) [CY2CP1504ZXC](#) [CY2DP1510AXC](#) [MC74HCT365ADTR2G](#) [BCM6306KMLG](#) [54FCT240CTDB](#) [Le87401NQC](#)  
[Le87402MQC](#) [028192B](#) [042140C](#) [051117G](#) [070519XB](#) [065312DB](#) [091056E](#) [098456D](#) [NL17SG07DFT2G](#) [NL17SG17DFT2G](#)  
[NL17SG34DFT2G](#) [NL17SZ07P5T5G](#) [NL17SZ125P5T5G](#) [NLU1GT126AMUTCG](#) [NLV27WZ16DFT2G](#) [NLV74LCX244DTR2G](#) [5962-](#)  
[8982101PA](#) [5962-9052201PA](#) [74LVC07ADR2G](#) [MC74VHC1G125DFT1G](#) [NL17SH17P5T5G](#) [NL17SZ125CMUTCG](#) [NLV17SZ07DFT2G](#)  
[NLV37WZ17USG](#) [NLVHCT244ADTR2G](#) [NC7WZ17FHX](#) [74HCT126T14-13](#) [NL17SH125P5T5G](#) [NLV14049UBDTR2G](#)  
[NLV37WZ07USG](#) [74VHC541FT\(BE\)](#) [SNJ54LVTH244AW](#) [74LVC1G17FW4-7](#) [74LVC1G126FZ4-7](#) [BCM6302KMLG](#) [74LVC1G07FZ4-7](#)