

**4:1 DIFFERENTIAL  
MULTIPLEXER****SY10EL57  
SY100EL57****FEATURES**

- 5V power supply
- Useful as either 4:1 or 2:1 multiplexer
- VBB output for single-ended operation
- 75K $\Omega$  internal input pulldown resistors
- Available in 150 mil 16-pin SOIC package

**DESCRIPTION**

The SY10/100EL57 are fully differential 4:1 multiplexers. By leaving the SEL1 line open (pulled LOW via the input pulldown resistors) the device can also be used as a differential 2:1 multiplexer with SEL0 input selecting between D0 and D1. The fully differential architecture of the EL57 makes it ideal for use in low skew applications such as clock distribution.

The SEL1 is the most significant select line. The binary number applied to the select inputs will select the same numbered data input (i.e., 00 selects D0).

Multiple VBB outputs are provided for single-ended or AC coupled interfaces. In these scenarios, the VBB output should be connected to the data bar inputs and bypassed via a 0.01 $\mu$ F capacitor to ground. Note that the VBB output can source/sink up to 0.5mA of current without upsetting the voltage level.

**TRUTH TABLE**

SEL1	SEL0	DATA OUT
L	L	D0
L	H	D1
H	L	D2
H	H	D3

**PIN NAMES**

Pin	Function
D0-3	Differential Data Inputs
SEL0, 1	Mux Select Inputs
VBB1, 2	Reference Outputs
Q	Data Outputs

**PACKAGE/ORDERING INFORMATION**

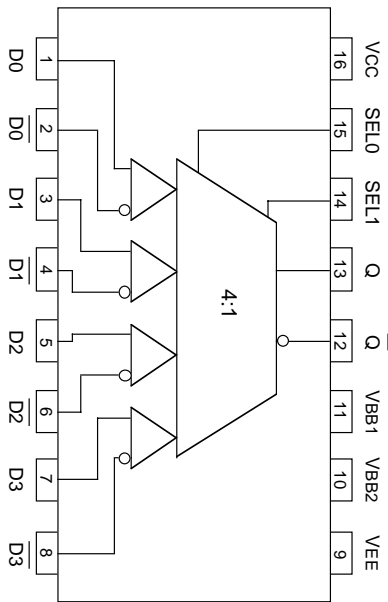

**16-Pin SOIC (Z16-1)**

**Ordering Information<sup>(1)</sup>**

Part Number	Package Type	Operating Range	Package Marking	Lead Finish
SY10EL57ZC	Z16-2	Commercial	SY10EL57ZC	Sn-Pb
SY10EL57ZCTR <sup>(2)</sup>	Z16-2	Commercial	SY10EL57ZC	Sn-Pb
SY100EL57ZC	Z16-2	Commercial	SY100EL57ZC	Sn-Pb
SY100EL57ZCTR <sup>(2)</sup>	Z16-2	Commercial	SY100EL57ZC	Sn-Pb
SY10EL57ZI	Z16-2	Industrial	SY10EL57ZI	Sn-Pb
SY10EL57ZITR <sup>(2)</sup>	Z16-2	Industrial	SY10EL57ZI	Sn-Pb
SY100EL57ZI	Z16-2	Industrial	SY100EL57ZI	Sn-Pb
SY100EL57ZITR <sup>(2)</sup>	Z16-2	Industrial	SY100EL57ZI	Sn-Pb
SY10EL57ZG <sup>(3)</sup>	Z16-2	Industrial	SY10EL57ZG with Pb-Free bar-line indicator	Pb-Free NiPdAu
SY10EL57ZGTR <sup>(2, 3)</sup>	Z16-2	Industrial	SY10EL57ZG with Pb-Free bar-line indicator	Pb-Free NiPdAu
SY100EL57ZG <sup>(3)</sup>	Z16-2	Industrial	SY100EL57ZG with Pb-Free bar-line indicator	Pb-Free NiPdAu
SY100EL57ZGTR <sup>(2, 3)</sup>	Z16-2	Industrial	SY100EL57ZG with Pb-Free bar-line indicator	Pb-Free NiPdAu

**Notes:**

1. Contact factory for die availability. Dice are guaranteed at T<sub>A</sub> = 25°C, DC Electricals only.
2. Tape and Reel.
3. Pb-Free package is recommended for new designs.

### ABSOLUTE MAXIMUM RATINGS<sup>(1)</sup>

Symbol	Rating	Value	Unit
VEE	Power Supply (V <sub>CC</sub> = 0V)	-8.0 to 0	V
V <sub>IN</sub>	Input Voltage (V <sub>CC</sub> = 0V)	0 to -6.0	V
I <sub>OUT</sub>	Output Current - Continuous - Surge	50 100	mA
T <sub>LEAD</sub>	Lead Storage Temperature	+260	°C
T <sub>A</sub>	Operating Temperature Range	-40 to +85	°C
VEE	Operating Range <sup>(1), (2)</sup>	-5.7 to -4.2	V

**Notes:**

1. Absolute maximum ratings, beyond which, device life may be impaired, unless otherwise specified on an individual data sheet.
2. Parametric values specified at: 5 volt Power Supply Range 100EL57 Series: -4.2V to -5.5V.  
10EL57 Series -4.75V to -5.5V.

### 10EL DC CHARACTERISTICS

V<sub>EE</sub> = -5.5 to -4.75V; V<sub>CC</sub> = GND = 0V<sup>(1)</sup>

Symbol	Parameter	T <sub>A</sub> = -40°C		T <sub>A</sub> = 0°C		T <sub>A</sub> = +25°C		T <sub>A</sub> = +85°C		Unit
		Min.	Max.	Min.	Max.	Min.	Max.	Min.	Max.	
V <sub>OH</sub>	Output HIGH Voltage	-1080	-890	-1020	-840	-980	-810	-910	-720	mV
V <sub>OL</sub>	Output LOW Voltage	-1950	-1650	-1950	-1630	-1950	-1630	-1950	-1595	mV
V <sub>IH</sub>	Input HIGH Voltage	-1230	-890	-1170	-840	-1130	-810	-1060	-720	mV
V <sub>IL</sub>	Input LOW Voltage	-1950	-1500	-1950	-1480	-1950	-1480	-1950	-1445	mV
I <sub>IL</sub>	Input LOW Current	0.5	—	0.5	—	0.5	—	0.5	—	µA

**Note:**

1. 10EL circuits are designed to meet the DC specifications shown in the table after thermal equilibrium has been established. The circuit is in a test socket or mounted on a printed circuit board and transverse airflow greater than 500lpm is maintained. Outputs are terminated through a 50Ω resistor to -2.0V except where otherwise specified on the individual data sheets.

### 100EL DC CHARACTERISTICS

V<sub>EE</sub> = -5.5 to -4.75V; V<sub>CC</sub> = GND = 0V<sup>(1)</sup>

Symbol	Parameter	T <sub>A</sub> = -40°C			T <sub>A</sub> = 0°C to 85°C			Unit	Condition
		Min.	Typ.	Max.	Min.	Typ.	Max.		
V <sub>OH</sub>	Output HIGH Voltage	-1085	-1005	-880	-1025	-955	-880	mV	V <sub>IN</sub> = V <sub>IH</sub> (Max) or V <sub>IL</sub> (Min)
V <sub>OL</sub>	Output LOW Voltage	-1830	-1695	-1555	-1810	-1705	-1620	mV	V <sub>IN</sub> = V <sub>IH</sub> (Max) or V <sub>IL</sub> (Min)
V <sub>OHA</sub>	Output HIGH Voltage	-1095	—	—	-1035	—	—	mV	V <sub>IN</sub> = V <sub>IH</sub> (Min) or V <sub>IL</sub> (Max)
V <sub>OLA</sub>	Output LOW Voltage	—	—	-1555	—	—	-1610	mV	V <sub>IN</sub> = V <sub>IH</sub> (Min) or V <sub>IL</sub> (Max)
V <sub>IH</sub>	Input HIGH Voltage	-1165	—	-880	-1165	—	-880	mV	
V <sub>IL</sub>	Input LOW Voltage	-1810	—	-1475	-1810	—	-1475	mV	
I <sub>IL</sub>	Input LOW Current	0.5	—	—	0.5	—	—	µA	V <sub>IN</sub> = V <sub>IL</sub> (Max)

**Note:**

1. The same DC parameter values at V<sub>EE</sub> = -4.5V now apply across the full V<sub>EE</sub> range of -4.2V to -5.5V. Outputs are terminated through a 50Ω resistor to -2.0V except where otherwise specified on the individual data sheets.

**DC ELECTRICAL CHARACTERISTICS**V<sub>EE</sub> = -5.5 to -4.2V; V<sub>CC</sub> = GND = 0V

Symbol	Parameter	T <sub>A</sub> = -40°C			T <sub>A</sub> = 0°C			T <sub>A</sub> = +25°C			T <sub>A</sub> = +85°C			Unit	
		Min.	Typ.	Max.	Min.	Typ.	Max.	Min.	Typ.	Max.	Min.	Typ.	Max.		
I <sub>EE</sub>	Power Supply Current	10EL	—	15	24	—	15	24	—	15	24	—	15	24	mA
	100EL	—	15	24	—	15	24	—	15	24	—	15	27		
V <sub>BB</sub>	Output Reference Voltage	10EL	-1.43	—	-1.30	-1.38	—	-1.27	-1.35	—	-1.25	-1.31	—	-1.19	V
	100EL	—	-1.38	—	-1.26	-1.38	—	-1.26	-1.38	—	-1.26	-1.38	—	-1.26	
I <sub>IH</sub>	Input HIGH Current	—	—	150	—	—	150	—	—	150	—	—	150	μA	

**AC ELECTRICAL CHARACTERISTICS**V<sub>EE</sub> = -5.5 to -4.2V; V<sub>CC</sub> = GND = 0V

Symbol	Parameter	T <sub>A</sub> = -40°C			T <sub>A</sub> = 0°C			T <sub>A</sub> = +25°C			T <sub>A</sub> = +85°C			Unit
		Min.	Typ.	Max.	Min.	Typ.	Max.	Min.	Typ.	Max.	Min.	Typ.	Max.	
t <sub>PD</sub>	Propagation Delay DATA to Q/Q	350	—	550	350	—	550	360	—	560	380	—	580	ps
	SEL to Q/Q	440	—	690	440	—	690	440	—	690	460	—	710	
t <sub>skew</sub>	Input Skew DATA to Q	—	—	50	—	—	50	—	—	50	—	—	50	ps
V <sub>PP</sub>	Minimum Input Swing DATA	150	—	—	150	—	—	150	—	—	150	—	—	mV
V <sub>CMR</sub>	Common Mode Range DATA	-2.0	—	-0.4	-2.0	—	-0.4	-2.0	—	-0.4	-2.0	—	-0.4	V
t <sub>r</sub> t <sub>f</sub>	Output Rise/Fall Times Q (20% - 80%)	125	—	375	125	—	375	125	—	375	125	—	375	ps

**16-PIN SOIC .150" WIDE (Z16-2)**

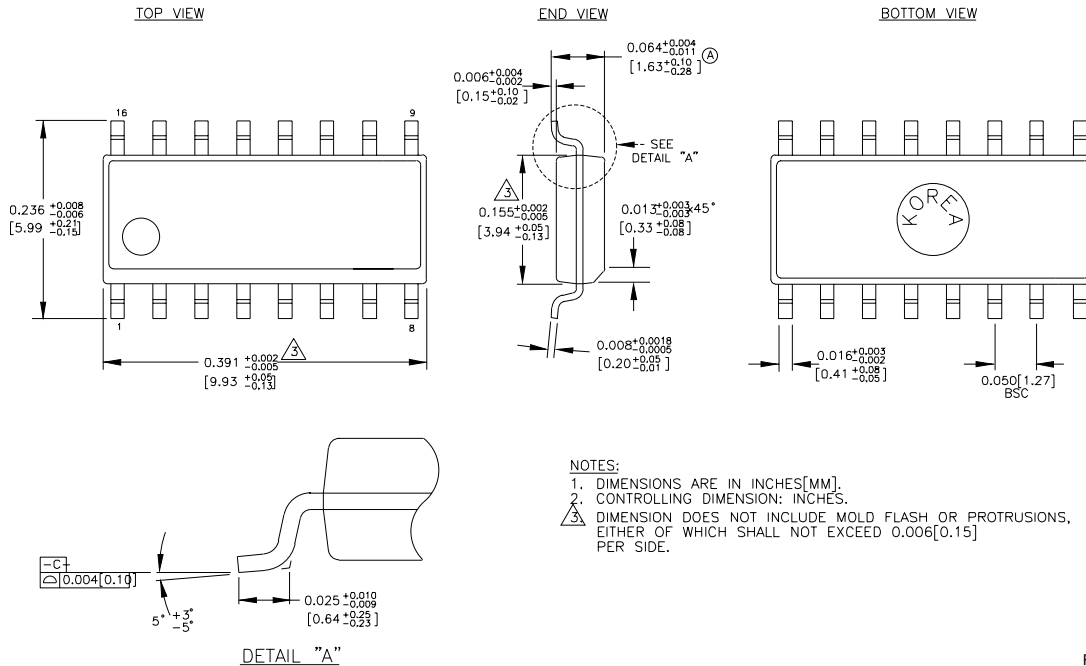

Rev. 02

**MICREL, INC. 2180 FORTUNE DRIVE SAN JOSE, CA 95131 USA**

TEL + 1 (408) 944-0800 FAX + 1 (408) 474-1000 WEB <http://www.micrel.com>

The information furnished by Micrel in this datasheet is believed to be accurate and reliable. However, no responsibility is assumed by Micrel for its use. Micrel reserves the right to change circuitry and specifications at any time without notification to the customer.

Micrel Products are not designed or authorized for use as components in life support appliances, devices or systems where malfunction of a product can reasonably be expected to result in personal injury. Life support devices or systems are devices or systems that (a) are intended for surgical implant into the body or (b) support or sustain life, and whose failure to perform can be reasonably expected to result in a significant injury to the user. A Purchaser's use or sale of Micrel Products for use in life support appliances, devices or systems is at Purchaser's own risk and Purchaser agrees to fully indemnify Micrel for any damages resulting from such use or sale.

© 2006 Micrel, Incorporated.

## X-ON Electronics

Largest Supplier of Electrical and Electronic Components

*Click to view similar products for [Encoders, Decoders, Multiplexers & Demultiplexers](#) category:*

*Click to view products by [Microchip](#) manufacturer:*

Other Similar products are found below :

[M38510/01406BEA](#) [MC74HC163ADTG](#) [74HC253N](#) [NLV74VHC1G01DFT1G](#) [NLVHC4851ADTR2G](#) [NLVHCT4851ADTR2G](#)  
[PI3B33X257BE](#) [M74HCT4052ADTR2G](#) [M74VHC1GT04DFT3G](#) [TC74AC138P\(F\)](#) [MC74LVX4051MNTWG](#) [NLV14028BDR2G](#)  
[NLV14051BDR2G](#) [NLV74HC238ADTR2G](#) [715428X](#) [COMX-CAR-210](#) [5962-8607001EA](#) [MAX3783UCM+D](#) [PI5C3253QEX](#)  
[8CA3052APGGI8](#) [TC74HC4051AF\(EL,F\)](#) [TC74VHC138F\(EL,K,F\)](#) [PI3B3251LE](#) [PI5C3251QEX](#) [PI3B3251QE](#) [74VHC4052AFT\(BJ\)](#)  
[PI3PCIE3415AZHEX](#) [NLV74HC4851AMNTWG](#) [MC74LVX257DG](#) [M74HC151YRM13TR](#) [M74HC151YTTR](#) [PI5USB31213XEAEX](#)  
[M74HCT4851ADWR2G](#) [XD74LS154](#) [AP4373AW5-7-01](#) [QS3VH251QG8](#) [QS4A201QG](#) [HCS500-I/SM](#) [MC74HC151ADTG](#)  
[TC4066BP\(N,F\)](#) [74ACT11139PWR](#) [74VHC238FT\(BJ\)](#) [74VHC4066AFT\(BJ\)](#) [74VHCT138AFT\(BJ\)](#) [5962-8682201JA](#) [74HC158D.652](#)  
[74HC4052D\(BJ\)](#) [74VHC138MTC](#) [COMX-CAR-P1](#) [JM38510/36001BEA](#)