

FEATURES

- 3.3V and 5V power supply options
- 230ps typical propagation delay
- High bandwidth to 3GHz
- 75kΩ internal input pulldown resistors
- Q output will default LOW with inputs open
- Available in 8-pin MSOP and SOIC packages

**ECL Pro™****DESCRIPTION**

The SY10EP01V is a 4-input OR/NOR gate. The device is functionally equivalent to the EL01 device, E101 (a quad version). The SY10EP01V is ideal for applications requiring the fastest AC performance available.

PIN NAMES

Pin	Function
D ₀ -D ₃	ECL Data Inputs
Q, /Q	ECL Data Outputs

TRUTH TABLE

D ₀	D ₁	D ₂	D ₃	Q	/Q
L	L	L	L	L	H
H	X	X	X	H	L
X	H	X	X	H	L
X	X	H	X	H	L
X	X	X	H	H	L
H	H	H	H	H	L

PACKAGE/ORDERING INFORMATION

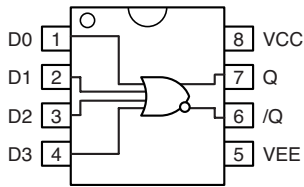

Available in 8-Pin SOIC and MSOP Packages

Ordering Information⁽¹⁾

Part Number	Package Type	Operating Range	Package Marking	Lead Finish
SY10EP01VZC	Z8-1	Commercial	HEP01	Sn-Pb
SY10EP01VZCTR ⁽²⁾	Z8-1	Commercial	HEP01	Sn-Pb
SY10EP01VKC	K8-1	Commercial	HP01	Sn-Pb
SY10EP01VKCTR ⁽²⁾	K8-1	Commercial	HP01	Sn-Pb
SY10EP01VZI	Z8-1	Industrial	HEP01	Sn-Pb
SY10EP01VZITR ⁽²⁾	Z8-1	Industrial	HEP01	Sn-Pb
SY10EP01VKI ⁽²⁾	K8-1	Industrial	HP01	Sn-Pb
SY10EP01VKITR ⁽²⁾	K8-1	Industrial	HP01	Sn-Pb
SY10EP01VZG ⁽³⁾	Z8-1	Industrial	HEP01 with Pb-Free bar-line indicator	NiPdAu Pb-Free
SY10EP01VZGTR ^(2, 3)	Z8-1	Industrial	HEP01 with Pb-Free bar-line indicator	NiPdAu Pb-Free
SY10EP01VKG ⁽³⁾	K8-1	Industrial	HP01 with Pb-Free bar-line indicator	NiPdAu Pb-Free
SY10EP01VKGTR ^(2, 3)	K8-1	Industrial	HP01 with Pb-Free bar-line indicator	NiPdAu Pb-Free

Notes:

1. Contact factory for die availability. Dice are guaranteed at T_A = 25°C, DC Electricals only.
2. Tape and Reel.
3. Pb-Free package is recommended for new designs.

ABSOLUTE MAXIMUM RATINGS⁽¹⁾

Symbol	Rating	Value	Unit
V_{CC}	Power Supply Voltage ($V_{EE} = 0$)	-6.0 to 0	V
V_{EE}	Power Supply Voltage ($V_{CC} = 0$)	+6.0 to 0	V
V_I	Input Voltage ($V_{CC} = 0V$)	-6.0 to 0	V
	Input Voltage ($V_{EE} = 0V$)	+6.0 to 0	V
I_{OUT}	Output Current -Continuous -Surge	50 100	mA mA
T_A	Operating Temperature Range	-40 to +85	°C
T_{LEAD}	Lead Temperature (Soldering, 20sec.)	+260	°C
T_{store}	Storage Temperature Range	-65 to +150	°C

Note 1. Permanent device damage may occur if absolute maximum ratings are exceeded. This is a stress rating only and functional operation is not implied at conditions other than those detailed in the operational sections of this data sheet. Exposure to absolute maximum rating conditions for extended periods may affect device reliability.

DC ELECTRICAL CHARACTERISTICS⁽¹⁾

$V_{CC} = 0V$; $V_{EE} = -5.5V$ to $-3.0V$; $V_{CC} = 3.0V$ to $5.5V$, $V_{EE} = 0V$ ⁽²⁾

Symbol	Parameter	$T_A = -40^\circ C$			$T_A = +25^\circ C$			$T_A = +85^\circ C$			Unit
		Min.	Typ.	Max.	Min.	Typ.	Max.	Min.	Typ.	Max.	
I_{EE}	Power Supply Current ⁽³⁾	—	—	31	—	20	31	—	—	31	mA
V_{OH}	Output HIGH Voltage ⁽⁴⁾	-1135	—	-0885	-1070	-0945	-0820	-1010	—	-0760	mV
V_{OL}	Output LOW Voltage ⁽⁴⁾	-1935	—	-1685	-1870	-1745	-1630	-1810	—	-1560	mV
V_{IH}	Input HIGH Voltage	-1210	—	-0885	-1145	—	-0820	-1085	—	-0760	mV
V_{IL}	Input LOW Voltage	-1935	—	-1610	-1870	—	-1545	-1810	—	-1485	mV
I_{IH}	Input HIGH Current	—	—	150	—	—	150	—	—	150	μA
I_{IL}	Input LOW Current	0.5	—	—	0.5	—	—	0.5	—	—	μA

Note 1. 10EP circuits are designed to meet the DC specifications shown in the above table after thermal equilibrium has been established. The circuit is in a test socket or mounted on a printed circuit board and traverse airflow greater than 500lfpm is maintained.

Note 2. Input and output parameters vary 1:1 with V_{CC} .

Note 3. $V_{CC} = 0V$, $V_{EE} = V_{EE}(\min)$ to $V_{EE}(\max)$, all other pins floating.

Note 4. All loading with 50Ω to $V_{CC} - 2.0V$.

AC ELECTRICAL CHARACTERISTICS
 $V_{CC} = 0V$, $V_{EE} = -3.0V$ to $-5.5V$; $V_{CC} = 3.0V$ to $5.5V$, $V_{EE} = 0V$

Symbol	Parameter	$T_A = -40^\circ C$			$T_A = +25^\circ C$			$T_A = +85^\circ C$			Unit
		Min.	Typ.	Max.	Min.	Typ.	Max.	Min.	Typ.	Max.	
f_{MAX}	Maximum Toggle Frequency ⁽¹⁾	—	—	—	—	3	—	—	—	—	GHz
t_{PD}	Propagation Delay to Output Differential D → Q, /Q	100	—	300	150	200	250	200	—	300	ps
t_{SKEW}	Device Skew ⁽²⁾	—	—	—	—	5	20	—	—	20	ps
t_r t_f	Output Rise/Fall Times Q (20% to 80%)	60	—	180	60	110	180	70	—	180	ps

Note 1. f_{MAX} guaranteed for functionality only. V_{OL} and V_{OH} levels are guaranteed at DC only.

Note 2. Skew difference between all inputs to output. Parameter not tested.

8-PIN MSOP (K8-1)

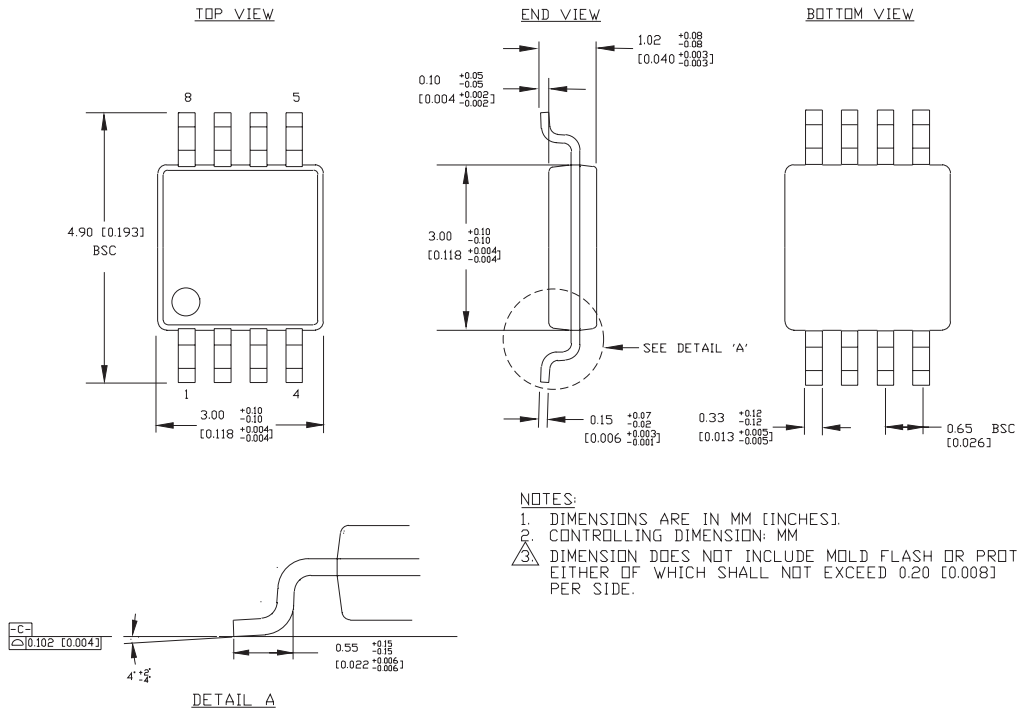

NOTES:
 1. DIMENSIONS ARE IN MM [INCHES]
 2. CONTROLLING DIMENSION: MM
 3. DIMENSION DOES NOT INCLUDE MOLD FLASH OR PROTRUSIONS, EITHER OF WHICH SHALL NOT EXCEED 0.20 [0.008] PER SIDE.

Rev.01

8-PIN PLASTIC SOIC (Z8-1)

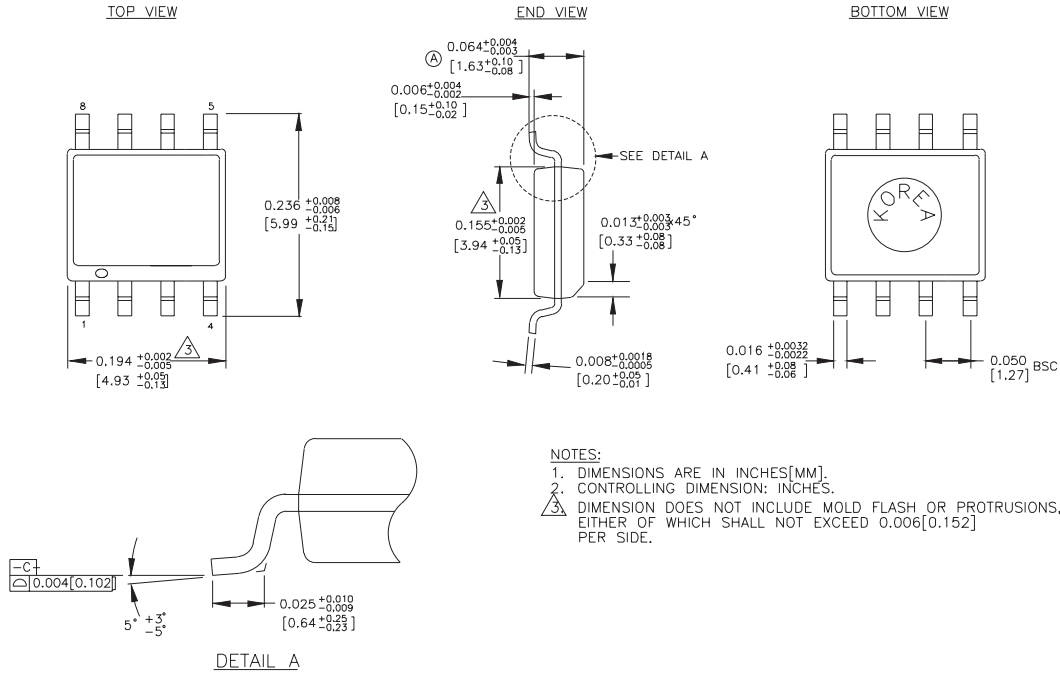

Rev. 03

MICREL, INC. 2180 FORTUNE DRIVE SAN JOSE, CA 95131 USA

TEL + 1 (408) 944-0800 FAX + 1 (408) 474-1000 WEB <http://www.micrel.com>

The information furnished by Micrel in this datasheet is believed to be accurate and reliable. However, no responsibility is assumed by Micrel for its use. Micrel reserves the right to change circuitry and specifications at any time without notification to the customer.

Micrel Products are not designed or authorized for use as components in life support appliances, devices or systems where malfunction of a product can reasonably be expected to result in personal injury. Life support devices or systems are devices or systems that (a) are intended for surgical implant into the body or (b) support or sustain life, and whose failure to perform can be reasonably expected to result in a significant injury to the user. A Purchaser's use or sale of Micrel Products for use in life support appliances, devices or systems is at Purchaser's own risk and Purchaser agrees to fully indemnify Micrel for any damages resulting from such use or sale.

© 2005 Micrel, Incorporated.

X-ON Electronics

Largest Supplier of Electrical and Electronic Components

Click to view similar products for [Logic Gates](#) category:

Click to view products by [Microchip](#) manufacturer:

Other Similar products are found below :

[5962-8769901BCA](#) [74HC85N](#) [NL17SG08P5T5G](#) [NL17SG32DFT2G](#) [NLU1G32AMUTCG](#) [NLV7SZ58DFT2G](#) [NLVHC1G08DFT1G](#)
[NLVVHC1G14DTT1G](#) [NLX2G08DMUTCG](#) [NLX2G08MUTCG](#) [MC74HCT20ADR2G](#) [091992B](#) [091993X](#) [093560G](#) [634701C](#) [634921A](#)
[NL17SG32P5T5G](#) [NL17SG86DFT2G](#) [NLU1G32CMUTCG](#) [NLV14001UBDR2G](#) [NLVVHC1G132DTT1G](#) [NLVVHC1G86DTT1G](#)
[NLX1G11AMUTCG](#) [NLX1G97MUTCG](#) [746427X](#) [74AUP1G17FW5-7](#) [74LS38](#) [74LVC1G08Z-7](#) [74LVC32ADTR2G](#) [74LVC1G125FW4-7](#)
[74LVC08ADTR2G](#) [MC74HCT20ADTR2G](#) [NLU1G08CMX1TCG](#) [NLV14093BDTR2G](#) [NLV17SZ00DFT2G](#) [NLV17SZ02DFT2G](#)
[NLV17SZ126DFT2G](#) [NLV27WZ17DFT2G](#) [NLV74HC02ADR2G](#) [NLV74HC08ADR2G](#) [NLVVHC1GT32DFT1G](#) [74HC32S14-13](#) [74LS133](#)
[74LVC1G32Z-7](#) [M38510/30402BDA](#) [74LVC1G86Z-7](#) [74LVC2G08RA3-7](#) [M38510/06202BFA](#) [NLV74HC08ADTR2G](#)
[NLV74HC14ADR2G](#)