

FEATURES

- 3.3V or 5V power supply options
- Maximum frequency > 3GHz typical
- 200ps typical propagation delay
- Internal input resistors: pulldown on D, pulldown and pullup on /D
- Q output will default LOW with inputs open or at V_{EE}
- Transistor count: 152
- Available in 8-Pin MSOP and SOIC packages

**ECL Pro™****DESCRIPTION**

The SY10EP08V is a 2-input differential XOR/XNOR gate. The EP08V is ideal for applications requiring the fastest AC performance available.

PIN NAMES

Pin	Function
$D_0, D_1, /D_0, /D_1$	ECL Data Inputs
$Q, /Q$	ECL Data Outputs

TRUTH TABLE

D_0	D_1	$/D_0$	$/D_1$	Q	/Q
L	L	H	H	L	H
L	H	H	L	H	L
H	L	L	H	H	L
H	H	L	L	L	H

PACKAGE/ORDERING INFORMATION

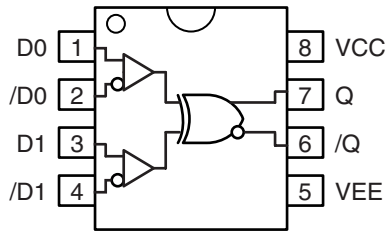

Available in 8-Pin SOIC and MSOP Packages

Ordering Information⁽¹⁾

Part Number	Package Type	Operating Range	Package Marking	Lead Finish
SY10EP08VZC	Z8-1	Commercial	HEP08V	Sn-Pb
SY10EP08VZCTR ⁽²⁾	Z8-1	Commercial	HEP08V	Sn-Pb
SY10EP08VKC	K8-1	Commercial	HP08	Sn-Pb
SY10EP08VKCTR ⁽²⁾	K8-1	Commercial	HP08	Sn-Pb
SY10EP08VZI	Z8-1	Industrial	HEP08V	Sn-Pb
SY10EP08VZITR ⁽²⁾	Z8-1	Industrial	HEP08V	Sn-Pb
SY10EP08VKI	K8-1	Industrial	HP08	Sn-Pb
SY10EP08VKITR ⁽²⁾	K8-1	Industrial	HP08	Sn-Pb
SY10EP08VZG ⁽³⁾	Z8-1	Industrial	HEP08V with Pb-Free bar-line indicator	Pb-Free NiPdAu
SY10EP08VZGTR ^(2, 3)	Z8-1	Industrial	HEP08V with Pb-Free bar-line indicator	Pb-Free NiPdAu
SY10EP08VKG ⁽³⁾	K8-1	Industrial	HP08 with Pb-Free bar-line indicator	Pb-Free NiPdAu
SY10EP08VKGTR ^(2, 3)	K8-1	Industrial	HP08 with Pb-Free bar-line indicator	Pb-Free NiPdAu

Notes:

1. Contact factory for die availability. Dice are guaranteed at T_A = 25°C, DC Electricals only.
2. Tape and Reel.
3. Pb-Free package is recommended for new designs.

ABSOLUTE MAXIMUM RATINGS⁽¹⁾

Symbol	Rating	Value	Unit
$V_{CC} - V_{EE}$	Power Supply Voltage	6V	V
V_{IN}	Input Voltage ($V_{CC} = 0V$, V_{IN} not more negative than V_{EE}) Input Voltage ($V_{EE} = 0V$, V_{IN} not more positive than V_{CC})	-6.0 to 0 +6.0 to 0	V V
I_{OUT}	Output Current -Continuous -Surge	50 100	mA
T_{LEAD}	Lead Temperature (soldering, 20sec.)	+260	°C
T_A	Operating Temperature Range	-40 to +85	°C
T_{store}	Storage Temperature Range	-65 to +150	°C
θ_{JA}	Package Thermal Resistance (Junction-to-Ambient) -Still-Air (SOIC) -500lfpm (SOIC) -Still-Air (MSOP) -500lfpm (MSOP)	160 109 206 155	°C/W °C/W
θ_{JC}	Package Thermal Resistance (Junction-to-Case) (SOIC) (MSOP)	39 39	°C/W

Note 1. Permanent device damage may occur if absolute maximum ratings are exceeded. This is a stress rating only and functional operation is not implied at conditions other than those detailed in the operational sections of this data sheet. Exposure to absolute maximum rating conditions for extended periods may affect device reliability.

3.3V LVPECL DC ELECTRICAL CHARACTERISTICS⁽¹⁾

$$V_{CC} = 3.3V \pm 0.3V, V_{EE} = 0V^{(2)}$$

Symbol	Parameter	$T_A = -40^\circ C$			$T_A = +25^\circ C$			$T_A = +85^\circ C$			Unit
		Min.	Typ.	Max.	Min.	Typ.	Max.	Min.	Typ.	Max.	
I_{EE}	Power Supply Current	20	28	36	20	30	38	20	32	38	mA
V_{OH}	Output HIGH Voltage ⁽³⁾	2165	2290	2415	2230	2355	2480	2290	2415	2540	mV
V_{OL}	Output LOW Voltage ⁽³⁾	1350	1490	1615	1350	1555	1680	1350	1615	1740	mV
V_{IH}	Input HIGH Voltage (Single-Ended)	2090	—	2415	2155	—	2480	2215	—	2540	mV
V_{IL}	Input LOW Voltage (Single-Ended)	1365	—	1690	1430	—	1755	1490	—	1815	mV
V_{IHCMR}	Input HIGH Voltage Common Mode Range (Diff.)	2.0	—	V_{CC}	2.0	—	V_{CC}	2.0	—	V_{CC}	V
I_{IH}	Input HIGH Current	—	—	150	—	—	150	—	—	150	μA
I_{IL}	Input LOW Current	D /D	0.5 -150	— —	0.5 -150	— —	— —	0.5 -150	— —	— —	μA

Note 1. 10EP circuits are designed to meet the DC specifications shown in the above table after thermal equilibrium has been established. The circuit is in a test socket or mounted on a printed circuit board and transverse airflow greater than 500lfpm is maintained.

Note 2. Input and output parameters vary 1:1 with V_{CC} .

Note 3. All loading with 50Ω to $V_{CC} - 2.0V$.

5.0V PECL DC ELECTRICAL CHARACTERISTICS⁽¹⁾

$V_{CC} = 5.0V \pm 0.5V, V_{EE} = 0V^{(2)}$

Symbol	Parameter	$T_A = -40^\circ\text{C}$			$T_A = +25^\circ\text{C}$			$T_A = +85^\circ\text{C}$			Unit
		Min.	Typ.	Max.	Min.	Typ.	Max.	Min.	Typ.	Max.	
I_{EE}	Power Supply Current	20	28	36	20	30	38	20	32	38	mA
V_{OH}	Output HIGH Voltage ⁽³⁾	3865	3990	4115	3930	4055	4180	3990	4115	4240	mV
V_{OL}	Output LOW Voltage ⁽³⁾	3050	3190	3315	3050	3255	3830	3050	3315	3440	mV
V_{IH}	Input HIGH Voltage (Single-Ended)	3790	—	4115	3855	—	4180	3915	—	4240	mV
V_{IL}	Input LOW Voltage (Single-Ended)	3065	—	3390	3130	—	3455	3190	—	3515	mV
V_{IHCMR}	Input HIGH Voltage Common Mode Range (Diff.)	2.0	—	V_{CC}	2.0	—	V_{CC}	2.0	—	V_{CC}	mV
I_{IH}	Input HIGH Current	—	—	150	—	—	150	—	—	150	μA
I_{IL}	Input LOW Current	D /D	0.5 -150	— —	0.5 -150	— —	— —	0.5 -150	— —	— —	μA

Note 1. 10EP circuits are designed to meet the DC specifications shown in the above table after thermal equilibrium has been established. The circuit is in a test socket or mounted on a printed circuit board and transverse airflow greater than 500lfpm is maintained.

Note 2. Input and output parameters vary 1:1 with V_{CC} .

Note 3. All loading with 50Ω to $V_{CC} - 2.0V$.

NECL DC ELECTRICAL CHARACTERISTICS⁽¹⁾

$V_{CC} = 0V, V_{EE} = -5.5V \text{ to } -3.0V$

Symbol	Parameter	$T_A = -40^\circ\text{C}$			$T_A = +25^\circ\text{C}$			$T_A = +85^\circ\text{C}$			Unit
		Min.	Typ.	Max.	Min.	Typ.	Max.	Min.	Typ.	Max.	
I_{EE}	Power Supply Current	20	28	36	20	30	38	20	32	38	mA
V_{OH}	Output HIGH Voltage ⁽²⁾	-1135	-1010	-885	-1070	-945	-820	-1010	-885	-760	mV
V_{OL}	Output LOW Voltage ⁽²⁾	-1950	-1810	-1685	-1950	-1745	-1620	-1950	-1685	-1560	mV
V_{IH}	Input HIGH Voltage (Single-Ended)	-1210	—	-885	-1145	—	-820	-1085	—	-760	mV
V_{IL}	Input LOW Voltage (Single-Ended)	-1935	—	-1610	-1870	—	-1545	-1810	—	-1485	mV
V_{IHCMR}	Input HIGH Voltage Common Mode Range (Diff.)	$V_{EE} + 2.0$		V_{CC}	$V_{EE} + 2.0$		V_{CC}	$V_{EE} + 2.0$		V_{CC}	mV
I_{IH}	Input HIGH Current	—	—	150	—	—	150	—	—	150	μA
I_{IL}	Input LOW Current	D /D	0.5 -150	— —	0.5 -150	— —	— —	0.5 -150	— —	— —	μA

Note 1. 10EP circuits are designed to meet the DC specifications shown in the above table after thermal equilibrium has been established. The circuit is in a test socket or mounted on a printed circuit board and transverse airflow greater than 500lfpm is maintained.

Note 2. All loading with 50Ω to $V_{CC} - 2.0V$.

AC ELECTRICAL CHARACTERISTICS
 $V_{CC} = 0V, V_{EE} = -3.0V \text{ to } -5.5V; V_{CC} = 3.0V \text{ to } 5.5V, V_{EE} = 0V^{(1)}$

Symbol	Parameter	$T_A = -40^\circ\text{C}$			$T_A = +25^\circ\text{C}$			$T_A = +85^\circ\text{C}$			Unit
		Min.	Typ.	Max.	Min.	Typ.	Max.	Min.	Typ.	Max.	
f_{MAX}	Maximum Toggle Frequency ⁽²⁾	—	—	> 3	—	—	> 3	—	—	> 3	GHz
t_{PLH} t_{PHL}	Propagation Delay to Output Differential D, /D → Q, /Q	100	—	240	120	200	260	150	—	300	ps
V_{PP}	Input Voltage Swing (Diff.)	150	800	1200	150	800	1200	150	800	1200	mV
t_r t_f	Output Rise/Fall Times Q, /Q (20% to 80%)	70	120	170	70	—	170	70	—	170	ps

Note 1. Measured using a 750mV source, 50% duty cycle clock source. All loading with 50Ω to $V_{CC} - 2.0V$.

Note 2. f_{MAX} guaranteed for functionality only. V_{OL} and V_{OH} levels are guaranteed at DC only.

8-PIN MSOP (K8-1)

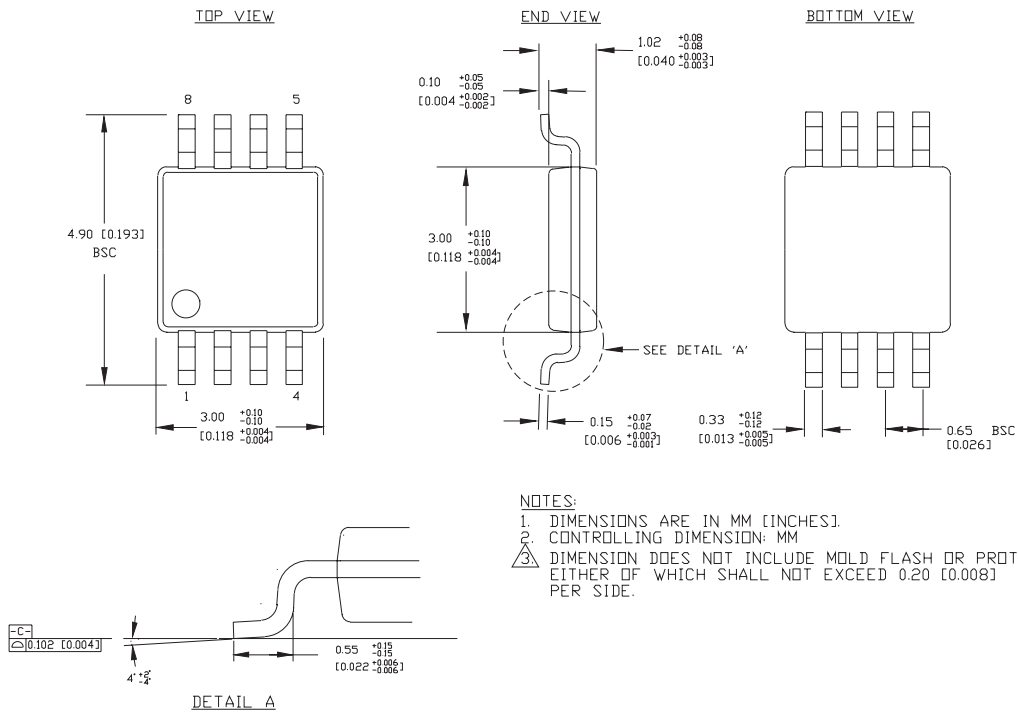

NOTES:
 1. DIMENSIONS ARE IN MM [INCHES]
 2. CONTROLLING DIMENSION: MM
 3. DIMENSION DOES NOT INCLUDE MOLD FLASH OR PROTRUSIONS, EITHER OF WHICH SHALL NOT EXCEED 0.20 [0.008] PER SIDE.

Rev. 01

8-PIN PLASTIC SOIC (Z8-1)

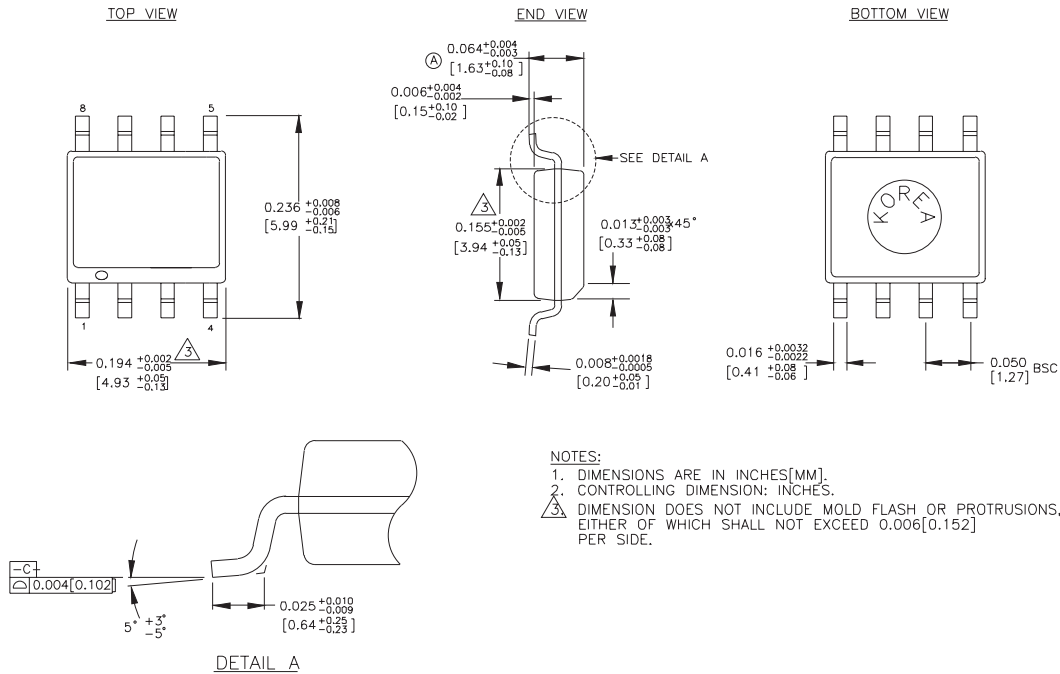

Rev. 03

MICREL, INC. 2180 FORTUNE DRIVE SAN JOSE, CA 95131 USA

TEL + 1 (408) 944-0800 FAX + 1 (408) 474-1000 WEB <http://www.micrel.com>

The information furnished by Micrel in this datasheet is believed to be accurate and reliable. However, no responsibility is assumed by Micrel for its use. Micrel reserves the right to change circuitry and specifications at any time without notification to the customer.

Micrel Products are not designed or authorized for use as components in life support appliances, devices or systems where malfunction of a product can reasonably be expected to result in personal injury. Life support devices or systems are devices or systems that (a) are intended for surgical implant into the body or (b) support or sustain life, and whose failure to perform can be reasonably expected to result in a significant injury to the user. A Purchaser's use or sale of Micrel Products for use in life support appliances, devices or systems is at Purchaser's own risk and Purchaser agrees to fully indemnify Micrel for any damages resulting from such use or sale.

© 2005 Micrel, Incorporated.

X-ON Electronics

Largest Supplier of Electrical and Electronic Components

Click to view similar products for [Logic Gates](#) category:

Click to view products by [Microchip](#) manufacturer:

Other Similar products are found below :

[5962-8769901BCA](#) [74HC85N](#) [NL17SG08P5T5G](#) [NL17SG32DFT2G](#) [NLU1G32AMUTCG](#) [NLV7SZ58DFT2G](#) [NLVHC1G08DFT1G](#)
[NLVVHC1G14DTT1G](#) [NLX2G08DMUTCG](#) [NLX2G08MUTCG](#) [MC74HCT20ADR2G](#) [091992B](#) [091993X](#) [093560G](#) [634701C](#) [634921A](#)
[NL17SG32P5T5G](#) [NL17SG86DFT2G](#) [NLU1G32CMUTCG](#) [NLV14001UBDR2G](#) [NLVVHC1G132DTT1G](#) [NLVVHC1G86DTT1G](#)
[NLX1G11AMUTCG](#) [NLX1G97MUTCG](#) [746427X](#) [74AUP1G17FW5-7](#) [74LS38](#) [74LVC1G08Z-7](#) [74LVC32ADTR2G](#) [74LVC1G125FW4-7](#)
[74LVC08ADTR2G](#) [MC74HCT20ADTR2G](#) [NLV14093BDTR2G](#) [NLV17SZ00DFT2G](#) [NLV17SZ02DFT2G](#) [NLV17SZ126DFT2G](#)
[NLV27WZ17DFT2G](#) [NLV74HC02ADR2G](#) [NLV74HC08ADR2G](#) [NLVVHC1GT32DFT1G](#) [74HC32S14-13](#) [74LS133](#) [74LVC1G32Z-7](#)
[M38510/30402BDA](#) [74LVC1G86Z-7](#) [74LVC2G08RA3-7](#) [M38510/06202BFA](#) [NLV74HC08ADTR2G](#) [NLV74HC14ADR2G](#)
[NLV74HC20ADR2G](#)