

FEATURES

- Single 5V power supply
- All V_{CC} pins isolated on chip
- Differentially drive balanced lines
- t_{PD} 1.3ns typical
- Fully compatible with MC10H351
- Available in 20-pin PLCC package

DESCRIPTION

The SY10H351 is a quad translator for interfacing data between a saturated logic selection and the PECL section of digital systems when only a +5.0V V_{DC} power supply is available. The SY10H351 has TTL/NMOS compatible inputs and PECL complementary open-emitter outputs that allow use as an inverting/non-inverting translator or as a differential line driver. When the common strobe input is at a low logic level, it forces all true outputs to the PECL low logic state ($\approx +3.2V$) and all inverting outputs to the PECL high logic state ($\approx 4.1V$).

The SY10H351 can also be used with the SY10H350 to transmit and receive TTL/NMOS information differentially via balanced twisted pair lines.

BLOCK DIAGRAM

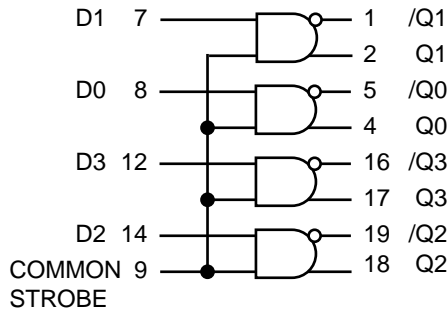

V_{CC} (+5 V_{DC}) = Pins 6, 11, 15, 20;
GND = Pin 10

PIN NAMES

Pin	Function
D0 – D3	Inputs
Q0 – Q3	Outputs
/Q0 – /Q3	Inverted outputs
VCC1	PECL V_{CC} (5.0V)
VCCE	PECL V_{CC} (5.0V)
VCCT	TTL V_{CC} (5.0V)
VCC2	PECL V_{CC} (5.0V)
Common Strobe	Common Strobe
GND	Ground

PACKAGE/ORDERING INFORMATION

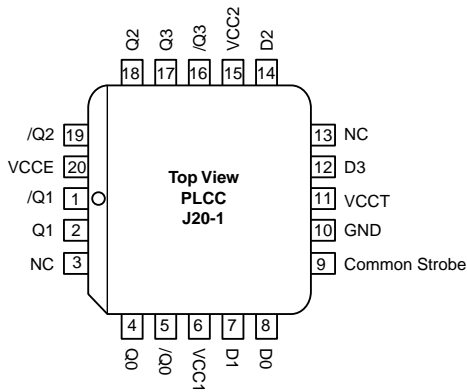

20-Pin PLCC (J20-1)

Ordering Information⁽¹⁾

Part Number	Package Type	Operating Range	Package Marking	Lead Finish
SY10H351JC	J20-1	Commercial	SY10H351JC	Sn-Pb
SY10H351JCTR ⁽²⁾	J20-1	Commercial	SY10H351JC	Sn-Pb
SY10H351JZ ⁽³⁾	J20-1	Commercial	SY10H351JZ with Pb-Free bar-line indicator	Matte-Sn
SY10H351JZTR ^(2, 3)	J20-1	Commercial	SY10H351JZ with Pb-Free bar-line indicator	Matte-Sn

Notes:

1. Contact factory for die availability. Dice are guaranteed at T_A = 25°C, DC Electricals only.
2. Tape and Reel.
3. Pb-Free package is recommended for new designs.

ABSOLUTE MAXIMUM RATINGS⁽¹⁾

Symbol	Parameter	Value	Unit
V _{CC}	Power Supply Voltage	-0.5 to +7.0	V
I _{OUT}	Output Current –Continuous –Surge	50 100	mA
T _{LEAD}	Lead Temperature (soldering, 20sec.)	+260	°C
T _{store}	Storage Temperature	-65 to +150	°C
T _A	Operating Temperature	0 to +85	°C

TRUTH TABLE

CS	D	Q	/Q
H	L	L	H
H	H	H	L
H	Open	H	L
L	X	L	H
Open	L	L	H
Open	H	H	L
Open	Open	H	L

Note:

1. Permanent device damage may occur if absolute maximum ratings are exceeded. This is a stress rating only and functional operation is not implied at conditions other than those detailed in the operational sections of this data sheet. Exposure to absolute maximum rating conditions for extended periods may affect device reliability.

DC ELECTRICAL CHARACTERISTICS

V_{CC1} = V_{CC2} = V_{CC3} = V_{CC4} = 4.75V to 5.25V

Symbol	Parameter	T _A = 0°C		T _A = +25°C			T _A = +85°C		Unit	Condition
		Min.	Max.	Min.	Typ.	Max.	Min.	Max.		
I _{CC}	Power Supply Current ECL ⁽¹⁾ TTL ⁽²⁾	—	45	—	—	45	—	45	mA	No output loads
		—	15	—	—	15	—	15		
I _R	Reverse Current (Pins 7, 8, 12, 14)	—	20	—	—	20	—	20	μA	
I _{INH}	Reverse Current, (Pin 9)	—	80	—	—	80	—	80	μA	
I _F	Forward Current (Pins 7, 8, 12, 14)	—	-0.6	—	—	-0.6	—	-0.6	mA	
I _{INL}	Forward Current, (Pin 9)	—	-2.4	—	—	-2.4	—	-2.4	mA	
V _{BR(in)}	Input Breakdown Voltage	5.5	—	5.5	—	—	5.5	—	V	
V _I	Input Clamp Voltage	—	-1.5	—	—	-1.5	—	-1.5	V	I _{IN} = -18mA
V _{OH}	Output HIGH Voltage ⁽³⁾	3.98	4.16	4.02	—	4.19	4.08	4.27	V	
V _{OL}	Output LOW Voltage ⁽³⁾	3.05	3.37	3.05	—	3.37	3.05	3.37	V	
V _{IH}	Input HIGH Voltage	2.0	—	2.0	—	—	2.0	—	V	
V _{IL}	Input LOW Voltage	—	0.8	—	—	0.8	—	0.8	V	

Notes:

1. Total I_{CC} at V_{CC1}, V_{CC2} and V_{CC3}.
2. I_{CC} at I_{CC1}.
3. These values are for V_{CC} = 5.0V. Level Specifications will vary 1:1 V_{CC}.

AC ELECTRICAL CHARACTERISTICS

VCC1 = VCC2 = VCCE = VCCT = 4.75V to 5.25V

Symbol	Parameter	TA = 0°C		TA = +25°C			TA = +85°C		Unit	Condition
		Min.	Max.	Min.	Typ.	Max.	Min.	Max.		
t _{PD}	Propagation Delay ⁽¹⁾	0.4	2.2	0.4	—	2.2	0.4	2.1	ns	50Ω to VCC–2V
t _r t _f	Output Rise/Fall Time (20% to 80%)	0.4	1.9	0.4	—	2.0	0.4	2.1	ns	50Ω to VCC–2V
f _{MAX}	Maximum Input Frequency ⁽²⁾	150	—	150	—	—	150	—	MHz	50Ω to VCC–2V

Notes:

1. Propagation delay is measured on this circuit from +1.5V on the input waveform to the 50% point on the output waveform.
2. These parameters are guaranteed but not tested.

SWITCHING WAVEFORM

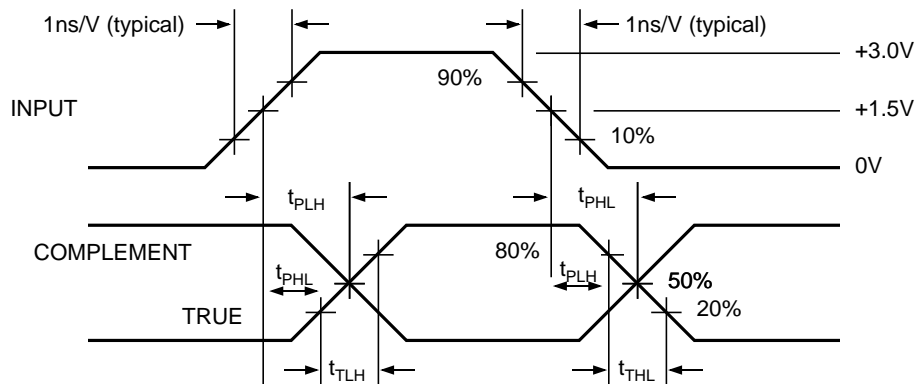
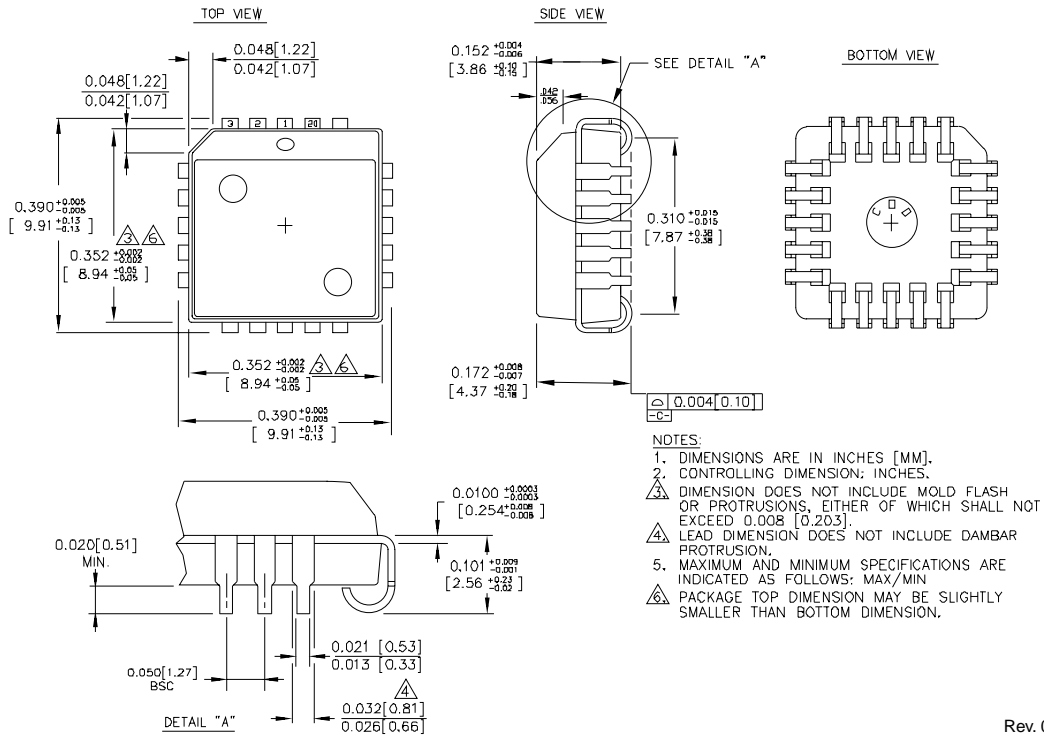

Figure 1. Propagation Delay and Transition Times

20-PIN PLASTIC LEADED CHIP CARRIER (J20-1)



Rev. 00

MICREL, INC. 2180 FORTUNE DRIVE SAN JOSE, CA 95131 USA

TEL + 1 (408) 944-0800 FAX + 1 (408) 474-1000 WEB <http://www.micrel.com>

The information furnished by Micrel in this data sheet is believed to be accurate and reliable. However, no responsibility is assumed by Micrel for its use. Micrel reserves the right to change circuitry and specifications at any time without notification to the customer.

Micrel Products are not designed or authorized for use as components in life support appliances, devices or systems where malfunction of a product can reasonably be expected to result in personal injury. Life support devices or systems are devices or systems that (a) are intended for surgical implant into the body or (b) support or sustain life, and whose failure to perform can be reasonably expected to result in a significant injury to the user. A Purchaser's use or sale of Micrel Products for use in life support appliances, devices or systems is at Purchaser's own risk and Purchaser agrees to fully indemnify Micrel for any damages resulting from such use or sale.

© 2006 Micrel, Incorporated.

X-ON Electronics

Largest Supplier of Electrical and Electronic Components

Click to view similar products for [Translation - Voltage Levels](#) category:

Click to view products by [Microchip](#) manufacturer:

Other Similar products are found below :

[NLSX4373DMR2G](#) [NLSX5012MUTAG](#) [NLSX0102FCT2G](#) [NLSX4302EBMUTCG](#) [PCA9306FMUTAG](#) [MC100EPT622MNG](#)
[NLSX5011MUTCG](#) [NLV9306USG](#) [NLVSX4014MUTAG](#) [NLSV4T3144MUTAG](#) [NLVSX4373MUTAG](#) [MAX3371ELT+T](#)
[NLSX3013BFCT1G](#) [NLV7WBD3125USG](#) [NLSX3012DMR2G](#) [74AVCH1T45FZ4-7](#) [NLVSV1T244MUTBG](#) [74AVC1T45GS-Q100H](#)
[CLVC16T245MDGGREP](#) [MC10H124FNG](#) [CAVCB164245MDGGREP](#) [CD40109BPWR](#) [MC10H350FNG](#) [MC10H125FNG](#)
[MC100EPT21MNR4G](#) [MC100EP91DWG](#) [NLSV2T244MUTAG](#) [NLSX3013FCT1G](#) [NLSX5011AMX1TCG](#) [PCA9306USG](#)
[SN74GTL1655DGGR](#) [SN74AVCA406LZQSR](#) [NLSX4014DTR2G](#) [NLSX3018DTR2G](#) [LTC1045CN#PBF](#) [SY100EL92ZG](#)
[74AXP1T34GMH](#) [74AXP1T34GNH](#) [LSF0204DPWR](#) [PI4ULS3V204LE](#) [ADG3245BRUZ-REEL7](#) [ADG3123BRUZ](#) [ADG3245BRUZ](#)
[ADG3246BCPZ](#) [ADG3308BCPZ-REEL](#) [ADG3233BRJZ-REEL7](#) [ADG3233BRMZ](#) [ADG3241BKSZ-500RL7](#) [ADG3242BRJZ-REEL7](#)
[ADG3243BRJZ-REEL7](#)