



2.5V/3.3V 3.0GHz DUAL 2 x 2 CML CROSSPOINT SWITCH w/INTERNAL TERMINATION

SuperLite™
SY55858U

FEATURES

- Guaranteed AC parameters over temperature:
 - $f_{MAX} > 3.0\text{GHz}$ (3Gbps)
 - $t_r/t_f < 120\text{ps}$
 - Within-device skew $< 25\text{ps}$
- Non-blocking “switch architecture”
- Configurable as dual 2:1 mux, dual 1:2 fanout buffer, 1:4 fanout buffer, quad buffer, or dual 2 x 2 switch
- 50Ω compatible outputs
- Unique input termination and V_T pin for DC-coupled and AC-coupled input signals—CML or PECL
- Fully differential inputs/outputs
- TTL/CMOS compatible control logic
- Wide supply voltage range: 2.3V to 3.6V
- Wide operating temperature range: -40°C to $+85^\circ\text{C}$
- Available in 32-pin EPAD-TQFP package

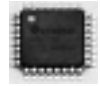

SuperLite™

DESCRIPTION

The SY55858U is a low-voltage, high-speed dual 2 x 2 crosspoint switch with a flexible input that accepts CML or PECL, and a 50Ω compatible differential CML (current-mode logic) output. The non-blocking design allows any input to connect to any output. Varying the state of the select inputs allows SY55858U to be used in backup, fault tolerant, protection and backplane distribution applications.

The signal inputs (DA_{0-1} and DB_{0-1}) have a unique internal termination design that allows access to the termination network through V_T pins. This feature allows the device to easily interface to other logic standards such as AC-coupled or DC-coupled PECL/LVPECL signals. For applications that require a single-channel 2 x 2 crosspoint, consider the SY55854.

APPLICATIONS

- SONET/SDH optical transport
- Backplane redundancy
- Add-drop Multiplexers

PACKAGE/ORDERING INFORMATION

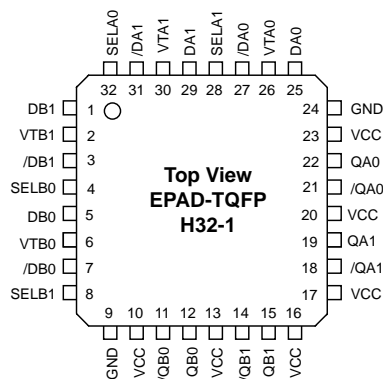

32-Pin EPAD-TQFP (H321)

Ordering Information⁽¹⁾

Part Number	Package Type	Operating Range	Package Marking	Lead Finish
SY55858UHI	H32-1	Industrial	SY55858UHI	Sn-Pb
SY55858UHITR ⁽²⁾	H32-1	Industrial	SY55858UHI	Sn-Pb
SY55858UHG ⁽³⁾	H32-1	Industrial	SY55858UHG with Pb-Free bar-line indicator	Pb-Free NiPdAu
SY55858UHGTR ^(2, 3)	H32-1	Industrial	SY55858UHG with Pb-Free bar-line indicator	Pb-Free NiPdAu

Notes:

1. Contact factory for die availability. Dice are guaranteed at T_A = 25°C, DC Electricals only.
2. Tape and Reel.
3. Pb-Free package recommended for new designs.

TRUTH TABLES

SELA0	SELA1	QA0	QA1	Function
0	0	DA0	DA0	Fanout Buffer or Redundant Distribution
0	1	DA0	DA1	Dual Buffer or Crosspoint
1	0	DA1	DA0	Dual Buffer or Crosspoint
1	1	DA1	DA1	Fanout Buffer or Redundant Distribution

Table 1. Input to Output Connectivity Crosspoint A

SELB0	SELB1	QB0	QB1	Function
0	0	DB0	DB0	Fanout Buffer or Redundant Distribution
0	1	DB0	DB1	Dual Buffer or Crosspoint
1	0	DB1	DB0	Dual Buffer or Crosspoint
1	1	DB1	DB1	Fanout Buffer or Redundant Distribution

Table 2. Input to Output Connectivity Crosspoint B

PIN DESCRIPTION

Pin Number	Pin Name	Pin Function
1	DB1	Channel B1 positive signal input.
2	VTB1	Channel B1 termination center-tap. For CML inputs, leave this pin floating. Otherwise, see Figures 5a–5d in “Input Interface Application” section.
3	/DB1	Channel B1 negative signal input.
4	SELB0	Channel B0 output select. TTL/CMOS input.
5	DB0	Channel B0 positive signal input.
6	VTB0	Channel B0 termination center-tap. For CML inputs, leave this pin floating. Otherwise, see Figures 5a–5d in “Input Interface Application” section.
7	/DB0	Channel B0 negative signal input.
8	SELB1	Channel B1 output select. TTL/CMOS input.
9, 24	GND	Supply Ground.
10, 13, 16, 17, 20, 23	VCC	Positive supply normally connect to 2.5V, 3.3V, or 5V nominal supply, and bypass each pin with 0.1μF//0.01μF low ESR capacitors.
11	/QB0	Channel B0 negative signal output. 50Ω CML.
12	QB0	Channel B0 positive signal output. 50Ω CML.
14	/QB1	Channel B1 negative signal output. 50Ω CML.
15	QB1	Channel B1 positive signal output. 50Ω CML.
18	/QA1	Channel A1 negative signal output. 50Ω CML.
19	QA1	Channel A1 positive signal output. 50Ω CML.
21	/QA0	Channel A0 negative signal output. 50Ω CML.
22	QA0	Channel A0 positive signal output. 50Ω CML.
25	DA0	Channel A0 positive signal input.
26	VTA0	Channel A0 termination center-tap. For CML inputs, leave this pin floating. Otherwise, see Figures 5a–5d in “Input Interface Application” section.
27	/DA0	Channel A0 negative signal input.
28	SELA1	Channel A1 output select. TTL/CMOS input.
29	DA1	Channel A1 positive signal input.
30	VTA1	Channel A1 termination center-tap. For CML inputs, leave this pin floating. Otherwise, see Figures 5a–5d in “Input Interface Application” section.
31	/DA1	Channel A1 negative signal input.
32	SELA0	Channel A1 output select. TTL/CMOS input.

FUNCTIONAL BLOCK DIAGRAM

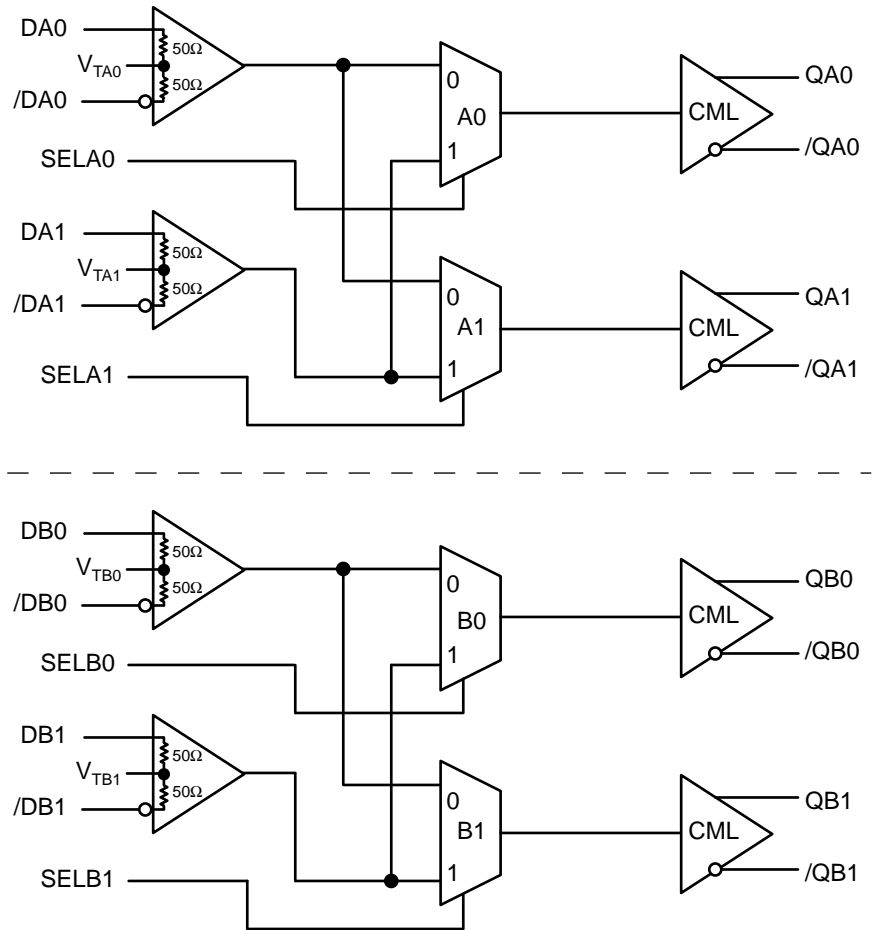

INPUT AND OUTPUT STAGE

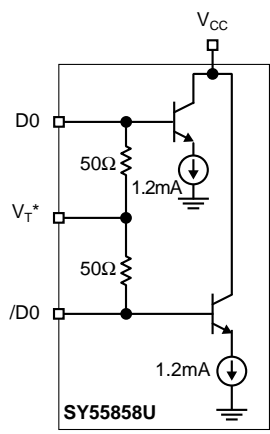

Figure 1. Input Stage

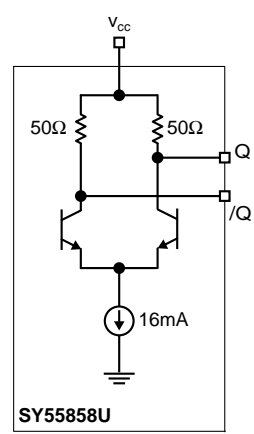

Figure 2. Output Stage

Note 1. See "Input Interface Applications" section for proper input connection.

ABSOLUTE MAXIMUM RATINGS⁽¹⁾

Symbol	Rating	Value	Unit	
V_{CC}	Power Supply Voltage	-0.5 to +6.0	V	
V_{IN}	Input Voltage	-0.5 to $V_{CC} + 0.5$	V	
V_{OUT}	CML Output Voltage	$V_{CC} - 1.0$ to $V_{CC} + 0.5$	V	
T_A	Operating Temperature Range	-40 to +85	°C	
T_{LEAD}	Lead Temperature (soldering, 20sec.)	260	°C	
T_{store}	Storage Temperature Range	-65 to +150	°C	
θ_{JA}	Package Thermal Resistance (Junction-to-Ambient)	-Still-Air (multi-layer PCB)	28	°C/W
		-500lfpm (multi-layer PCB)	20	°C/W
θ_{JC}	Package Thermal Resistance (Junction-to-Case)	4	°C/W	

Note 1. Permanent device damage may occur if absolute maximum ratings are exceeded. This is a stress rating only and functional operation is not implied at conditions other than those detailed in the operational sections of this data sheet. Exposure to absolute maximum rating conditions for extended periods may affect device reliability.

DC ELECTRICAL CHARACTERISTICS

Symbol	Parameter	Min.	Typ.	Max.	Unit	Condition
V_{CC}	Power Supply Voltage	2.3	—	3.6	V	
I_{CC}	Power Supply Current	—	150	190	mA	No load, over temp.

TTL CONTROL ELECTRICAL CHARACTERISTICS

$V_{CC} = 2.3V$ to $3.6V$; $GND = 0V$; $T_A = -40^\circ C$ to $+85^\circ C$ ⁽²⁾

Symbol	Parameter	Min.	Typ.	Max.	Unit	Condition
V_{IH}	Input HIGH Voltage	2.0	—	—	V	
V_{IL}	Input LOW Voltage	—	—	0.8	V	
I_{IH}	Input HIGH Current	—	—	+20	μA	$V_{IN} = 2.7V$, $V_{CC} = \text{Max.}$ $V_{IN} = V_{CC}$, $V_{CC} = \text{Max.}$
		—	—	+100	μA	
I_{IL}	Input LOW Current	-300	—	—	μA	$V_{IN} = 0.5V$, $V_{CC} = \text{Max.}$

Note 2. Specifications are guaranteed after thermal equilibrium has been established.

CML DC ELECTRICAL CHARACTERISTICS $V_{CC} = 2.3V$ to $3.6V$; $GND = 0V$; $T_A = -40^{\circ}C$ to $+85^{\circ}C$ ⁽³⁾

Symbol	Parameter	Min.	Typ.	Max.	Unit	Condition
V_{ID}	Differential Input Voltage	100	—	—	mV	
R_{IN}	Differential Input Resistance D-to-/D	90	100	110	Ω	
V_{IH}	Input HIGH Voltage	1.6	—	V_{CC}	V	
V_{IL}	Input LOW Voltage	1.5	—	$V_{CC} - 0.1$	V	
V_{OH}	Output HIGH Voltage	$V_{CC} - 0.040$	$V_{CC} - 0.010$	V_{CC}	V	No Load
V_{OL}	Output LOW Voltage	$V_{CC} - 1.00$	$V_{CC} - 0.800$	$V_{CC} - 0.650$	V	No Load
$V_{OUT(SWING)}$	Output Voltage Swing ⁽⁴⁾	0.650 —	0.800 0.400	1.00 —	V	No Load 50 Ω Environment
R_{OUT}	Output Source Impedance	40	50	60	Ω	

Note 3. Device is guaranteed to meet the DC specifications, shown in the table above, after thermal equilibrium has been established. The device is tested in a socket such that traverse airflow ≥ 500 lfpm is maintained.

Note 4. $V_{OUT(SWING)}$ is defined as the swing on one output of a differential pair, that is $|V_{OH} - V_{OL}|$ on one pin. The swing for common mode immunity purposes is $2 \times V_{OUT(SWING)}$. Actual voltage levels and differential swing will depend on customer termination scheme. Typically, a 400mV swing is available in the 50 Ω environment. Refer to the "CML Output Termination Application" section, Figures 3 and 4, for more details.

AC ELECTRICAL CHARACTERISTICS $V_{CC} = 2.3V$ to $3.6V$; $GND = 0V$; $T_A = -40^{\circ}C$ to $+85^{\circ}C$ ⁽⁵⁾

Symbol	Parameter	Min.	Typ.	Max.	Unit	Condition
f_{MAX}	Maximum Frequency NRZ Data Rate	3.0	—	—	Gbps	
	Clock Frequency ⁽⁶⁾	3.0	—	—	GHz	
t_{PLH} t_{PHL}	Differential Propagation Delay D-to-Q	220	350	450	ps	
t_{SWITCH}	Select-to-Valid Output ⁽⁷⁾	—	0.50	1.0	ns	
t_{SKEW}	Within-Device Skew ⁽⁸⁾	—	12	25	ps	
	Within-Device Skew ⁽⁹⁾	—	25	50	ps	
	Part-to-Part Skew (Diff.)	—	100	—		
R_J	Random Jitter	—	2	5	ps _{RMS}	
D_J	Deterministic Jitter	—	5	20	ps _{PP}	
t_r, t_f	CML Output Rise/Fall Times (20% to 80%)	—	80	120	ps	

Note 5. Tested using environment of Figure 3, 50 Ω equivalent load. AC parameters are guaranteed by design and characterization.

Note 6. f_{MAX} clock is defined as the maximum toggle rate the device can operate while still achieving a 250mV minimum CML output swing, 50 Ω equivalent load.

Note 7. Input TTL/CMOS edge rate of <1.5 ns.

Note 8. Worst-case difference between QA0 and QA1 from either DA0 or DA1 (or between QB0 and QB1 from either DB0 or DB1 respectively), when both outputs come from the same input.

Note 9. Worst-case difference between QA and QB outputs, when DA or DB inputs are shorted.

CML OUTPUT TERMINATION APPLICATION

All CML inputs accept a CML output from any other member of this family. All CML outputs are source terminated

50Ω differential drivers as shown in **Figure 3**.

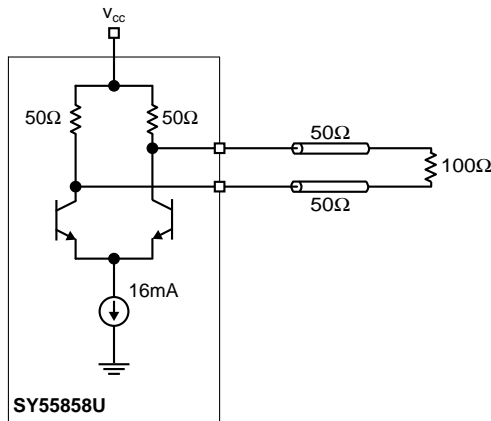

Figure 3. 50Ω Output Termination

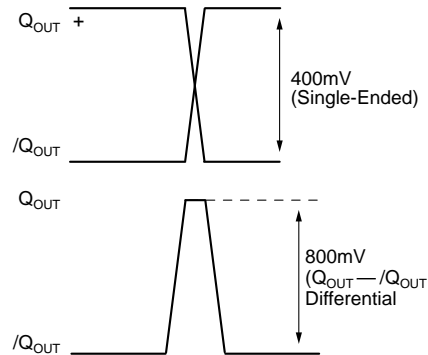

Figure 4. Output Levels

INPUT INTERFACE APPLICATIONS

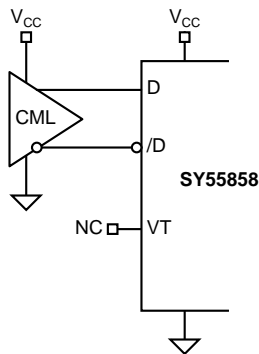

Figure 5a. CML-to-CML (DC-Coupled) Input Interface

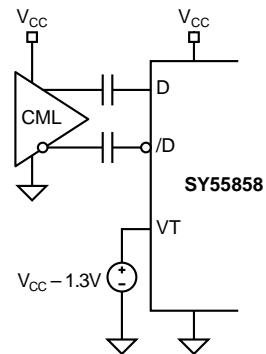

Figure 5b. CML-to-CML (AC-Coupled) Input Interface

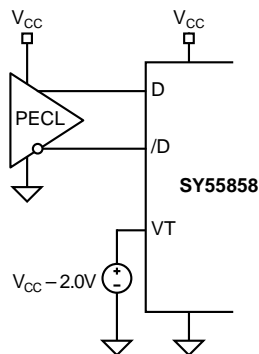

Figure 5c. PECL-to-CML (DC-Coupled) Input Interface

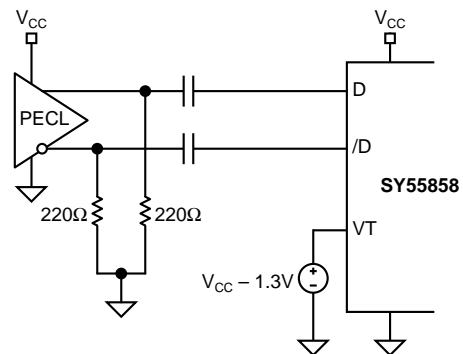
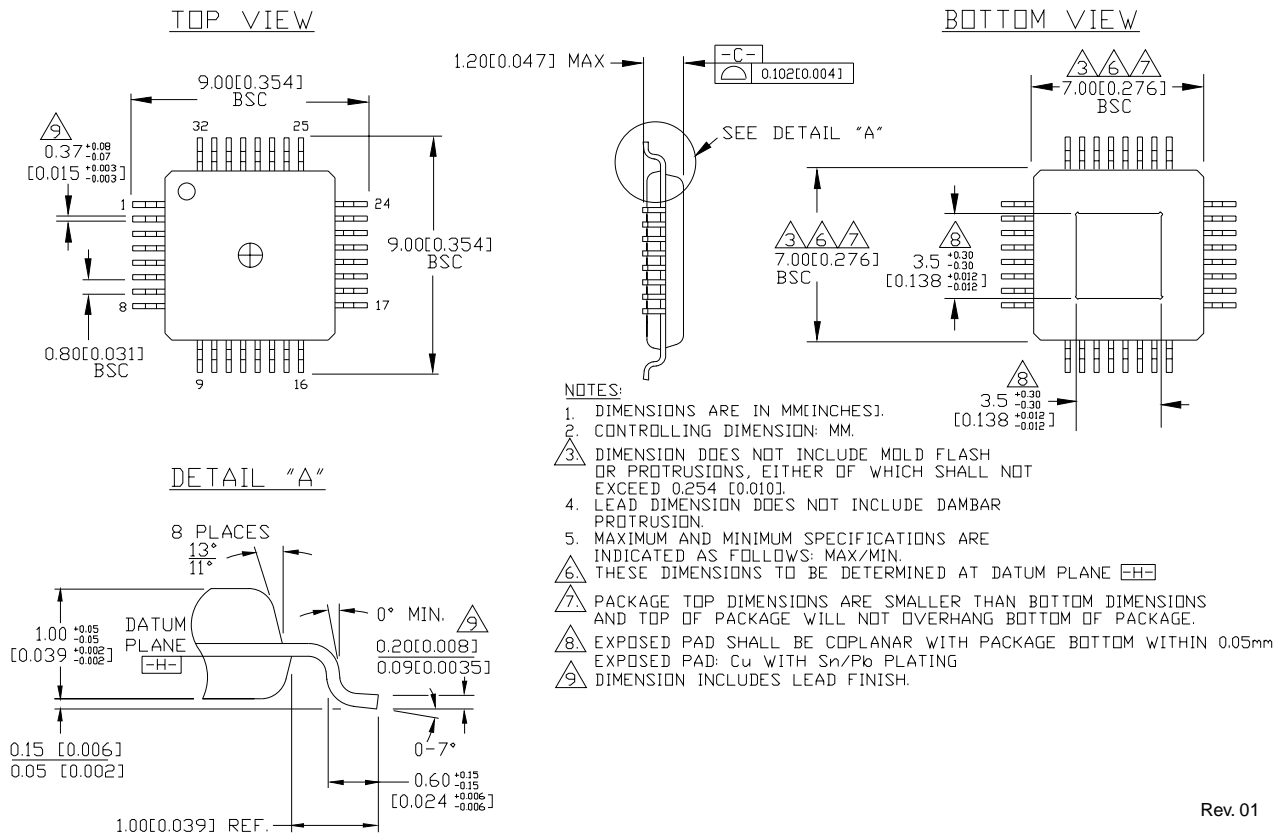

Figure 5d. PECL-to-CML (AC-Coupled) Input Interface

32 -PIN EPAD-TQFP (DIE UP) (H32-1)



Rev. 01

MICREL, INC. 2180 FORTUNE DRIVE SAN JOSE, CA 95131 USA

TEL + 1 (408) 944-0800 FAX + 1 (408) 474-1000 WEB <http://www.micrel.com>

The information furnished by Micrel in this datasheet is believed to be accurate and reliable. However, no responsibility is assumed by Micrel for its use. Micrel reserves the right to change circuitry and specifications at any time without notification to the customer.

Micrel Products are not designed or authorized for use as components in life support appliances, devices or systems where malfunction of a product can reasonably be expected to result in personal injury. Life support devices or systems are devices or systems that (a) are intended for surgical implant into the body or (b) support or sustain life, and whose failure to perform can be reasonably expected to result in a significant injury to the user. A Purchaser's use or sale of Micrel Products for use in life support appliances, devices or systems is at Purchaser's own risk and Purchaser agrees to fully indemnify Micrel for any damages resulting from such use or sale.

© 2005 Micrel, Incorporated.

X-ON Electronics

Largest Supplier of Electrical and Electronic Components

Click to view similar products for [Analogue & Digital Crosspoint ICs](#) category:

Click to view products by [Microchip](#) manufacturer:

Other Similar products are found below :

[MT093AE1](#) [MT8808AE1](#) [ADV3203ASWZ](#) [AD8177ABPZ](#) [ISPGDX240VA-4B388](#) [VSC3308YKU](#) [LX64EV-3F100C](#) [ISPGDX240VA-4BN388](#) [LX256EV-5FN484C](#) [GX4002-INE3](#) [AD8112JSTZ](#) [AD8115ASTZ](#) [SN65LVCP22D](#) [ADV3205JSTZ](#) [SY89540UMY](#) [AD75019JPZ](#) [AD75019JPZ-REEL](#) [AD8106ASTZ](#) [AD8107ASTZ](#) [AD8108ASTZ](#) [AD8109ASTZ](#) [AD8110ASTZ](#) [AD8111ASTZ](#) [AD8116JSTZ](#) [AD8152JBPZ](#) [AD8153ACPZ](#) [AD8155ACPZ](#) [AD8159ASVZ](#) [ADN4604ASVZ](#) [AD8153ACPZ-RL7](#) [ADN4612ACPZ](#) [ADV3201ASWZ](#) [ADV3226ACPZ](#) [ADV3227ACPZ](#) [ADV3228ACPZ](#) [ADV3229ACPZ](#) [HMC858LC4B](#) [MAX4550CAI+](#) [EL4544IGZ](#) [HA4314BCPZ](#) [MAX9152EUE+T](#) [MAX4360EAX+](#) [MAX4549EAX+](#) [MAX4549EAX+T](#) [MAX4570CAI+](#) [TEA6422D](#) [SY55858UHG](#) [NB4L858MFAG](#) [NB4N840MMNG](#) [NB6L72MMNG](#)