

FEATURES

- Provides six ultra-low skew copies of the selected input
- 2:1 MUX input included for clock switchover applications
- Guaranteed AC performance over temperature and voltage:
 - Clock frequency range: DC to >4.5GHz
 - <320ps IN-to-OUT t_{pd}
 - <110ps t_r/t_f times
 - <20ps skew (output-to-output)
- Ultra-low jitter design:
 - 50fs_{RMS} phase jitter (typ)
- Low supply voltage operation: 2.5V and 3.3V
- Unique input termination and VT pin accepts DC-coupled and AC-coupled inputs (CML, PECL, LVDS)
- Unique input isolation design minimizes crosstalk
- 100K LVPECL compatible output swing
- -40°C to +85°C temperature range
- Available in 32-pin (5mm x 5mm) MLF® package



Precision Edge®

DESCRIPTION

The SY58035U is a 2.5V/3.3V precision, high-speed, 1:6 fanout capable of handling clocks up to 4.5GHz. A differential 2:1 MUX input is included for redundant clock switchover applications.

The differential input includes Micrel's unique, 3-pin input termination architecture that allows the device to interface to any differential signal (AC- or DC-coupled) as small as 100mV without any level shifting or termination resistor networks in the signal path. The outputs are LVPECL (100K, temperature compensated), with extremely fast rise/fall times guaranteed to be less than 110ps.

The SY58035U operates from a 2.5V ±5% supply or a 3.3V ±10% supply and is guaranteed over the full industrial temperature range of -40°C to +85°C. For applications that require CML outputs, consider the SY58034U or for 400mV LVPECL outputs the SY58036U. The SY58035U is part of Micrel's high-speed, Precision Edge® product line.

All support documentation can be found on Micrel's web site at www.micrel.com.

APPLICATIONS

- Redundant clock distribution
- All SONET/SDH clock/data distribution
- All Fibre Channel distribution
- All Gigabit Ethernet clock distribution

FUNCTIONAL BLOCK DIAGRAM

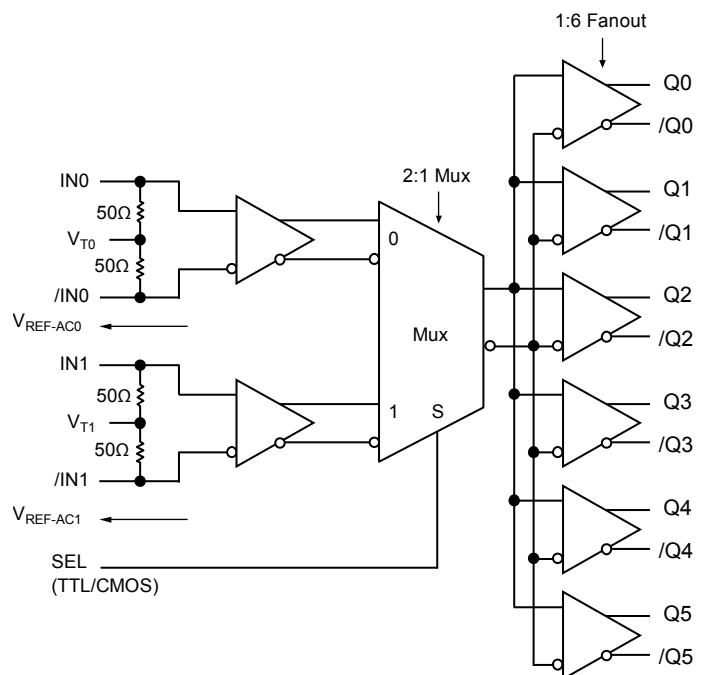

PACKAGE/ORDERING INFORMATION

Ordering Information⁽¹⁾

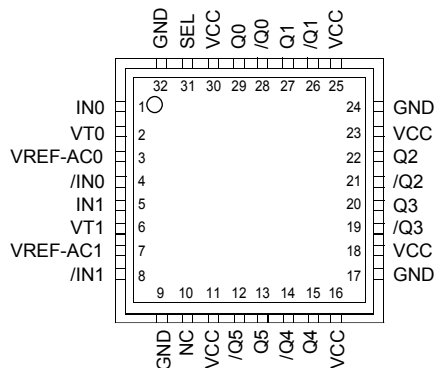

32-Pin MLF® (MLF-32)

Part Number	Package Type	Operating Range	Package Marking	Lead Finish
SY58035UMI	MLF-32	Industrial	SY58035U	Sn-Pb
SY58035UMITR ⁽²⁾	MLF-32	Industrial	SY58035U	Sn-Pb
SY58035UMG ⁽³⁾	MLF-32	Industrial	SY58035U with Pb-Free bar-line indicator	NiPdAu Pb-Free
SY58035UMGTR ^(2, 3)	MLF-32	Industrial	SY58035U with Pb-Free bar-line indicator	NiPdAu Pb-Free

Notes:

1. Contact factory for die availability. Dice are guaranteed at T_A = 25°C, DC electricals only.
2. Tape and Reel.
3. Pb-Free package recommended for new designs.

PIN DESCRIPTION

Pin Number	Pin Name	Pin Function
1, 4 5, 8	IN0, /IN0 IN1, /IN1	Differential Input: These input pairs are the differential signal inputs to the device. These inputs accept AC- or DC-coupled signals as small as 100mV. Each pin of a pair internally terminates to a VT pin through 50Ω. Note that these inputs will default to an indeterminate state if left open. Please refer to the “Input Interface Applications” section for more details.
2, 6	VT0, VT1	Input Termination Center-Tap: Each side of the differential input pair terminates to a VT pin. The VT0 and VT1 pins provide a center-tap to a termination network for maximum interface flexibility. See “Input Interface Applications” section for more details.
31	SEL	This single-ended TTL/CMOS-compatible input selects the inputs to the multiplexer. Note that this input is internally connected to a 25kΩ pull-up resistor and will default to a logic HIGH state if left open. The MUX select switchover function is asynchronous.
10	NC	No connect.
11, 16, 18, 23, 25, 30	VCC	Positive Power Supply: Bypass with 0.1μF 0.01μF low ESR capacitors and place as close to the VCC pin as possible.
29, 28 27, 26 22, 21 20, 19 15, 14 13, 12	Q0, /Q0, Q1, /Q1, Q2, /Q2, Q3, /Q3, Q4, /Q4, Q5, /Q5	Differential Outputs: These 100K (temperature compensated) LVPECL output pairs are low skew copies of the selected input. Please refer to the “Truth Table” for details.
9, 17, 24, 32	GND, Exposed Pad	Ground: Ground pin and exposed pad must be connected to the same ground plane.
3, 7	VREF-AC0 VREF-AC1	Reference Voltage: These output biases to V _{CC} -1.2V. It is used for AC-coupling inputs (IN, /IN). Connect V _{REF-AC} directly to the VT pin. Bypass with 0.01μF low ESR capacitor to V _{CC} . See “Input Interface Applications” section. Maximum sink/source current is ±1.5mA. Due to the limited drive capability, the VREF-AC pin is only intended to drive its respective VT pin.

TRUTH TABLE

SEL	
0	IN0 Input Selected
1	IN1 Input Selected

Absolute Maximum Ratings(1)

Power Supply Voltage (V_{CC})	-0.5V to +4.0V
Input Voltage (V_{IN})	-0.5V to V_{CC}
LVPECL Output Current (I_{OUT})		
Continuous	50mA
Surge	100mA
Termination Current		
Source or sink current on V_T pin	± 100 mA
Input Current		
Source or sink current on IN, /IN pin	± 50 mA
Source or sink current on VREF-AC pin	± 2 mA
Lead Temperature (soldering, 10 sec.)	220°C
Storage Temperature Range (T_S)	-65°C to +150°C

Operating Ratings(2)

Power Supply Voltage (V_{CC})	+2.375V to +2.625V
	+3.0V to +3.6V
Ambient Temperature Range (T_A)	-40°C to +85°C
Package Thermal Resistance(3)		
MLF® (θ_{JA})		
Still-Air	35°C/W
MLF® (ψ_{JB})		
Junction-to-Board	16°C/W

DC ELECTRICAL CHARACTERISTICS(4)

$T_A = -40^\circ\text{C}$ to $+85^\circ\text{C}$, unless otherwise stated.

Symbol	Parameter	Condition	Min	Typ	Max	Units
V_{CC}	Power Supply Voltage		2.375	2.5	2.625	V
			3.0	3.3	3.6	V
I_{CC}	Power Supply Current	No load, max. V_{CC}		185	250	mA
R_{DIFF_IN}	Differential Input Resistance (IN-to-/IN)		90	100	110	Ω
R_{IN}	Input Resistance (IN-to- V_T)		45	50	55	Ω
V_{IH}	Input HIGH Voltage (IN, /IN)		$V_{CC}-1.2$		V_{CC}	V
V_{IL}	Input LOW Voltage (IN, /IN)		0		$V_{IH}-0.1$	V
V_{IN}	Input Voltage Swing (IN, /IN)	See Figure 1a	0.1		1.7	V
V_{DIFF_IN}	Differential Input Voltage Swing IN, /IN	See Figure 1b	0.2			mV
V_T IN	IN to V_T (IN, /IN)				1.28	V
V_{REF-AC}	Reference Voltage		$V_{CC}-1.3$	$V_{CC}-1.2$	$V_{CC}-1.1$	V

Notes:

1. Permanent device damage may occur if absolute maximum ratings are exceeded. This is a stress rating only and functional operation is not implied at conditions other than those detailed in the operational sections of this data sheet. Exposure to absolute maximum ratings conditions for extended periods may affect device reliability.
2. The data sheet limits are not guaranteed if the device is operated beyond the operating ratings.
3. Thermal performance assumes exposed pad is soldered (or equivalent) to the device's most negative potential on the PCB. ψ_{JB} and θ_{JA} are shown for a 4-layer PCB in a still air environment, unless otherwise stated.
4. The circuit is designed to meet the DC specifications shown in the above table after thermal equilibrium has been established.
5. V_{IH} (min) not lower than 1.2V.

LVPECL OUTPUT DC ELECTRICAL CHARACTERISTICS⁽⁶⁾

$V_{CC} = 2.5V \pm 5\%$ or $3.3V \pm 10\%$; $T_A = -40^\circ C$ to $+85^\circ C$; $R_L = 50\Omega$ to $V_{CC} - 2V$, unless otherwise stated.

Symbol	Parameter	Condition	Min	Typ	Max	Units
V_{OH}	Output HIGH Voltage		$V_{CC} - 1.145$		$V_{CC} - 0.895$	V
V_{OL}	Output LOW Voltage		$V_{CC} - 1.945$		$V_{CC} - 1.695$	V
V_{OUT}	Output Differential Swing	See Figure 1a	550	800		mV
V_{DIFF_OUT}	Differential Output Voltage Swing	See Figure 1b	1.1	1.6		V

LVTTTL/CMOS DC ELECTRICAL CHARACTERISTICS⁽⁶⁾

$V_{CC} = 2.5V \pm 5\%$ or $3.3V \pm 10\%$; $T_A = -40^\circ C$ to $85^\circ C$, unless otherwise stated.

Symbol	Parameter	Condition	Min	Typ	Max	Units
V_{IH}	Input HIGH Voltage		2.0			V
V_{IL}	Input LOW Voltage				0.8	V
I_{IH}	Input HIGH Current		-125		40	μA
I_{IL}	Input LOW Current		-300			μA

Note:

6. The circuit is designed to meet the DC specifications shown in the above table after thermal equilibrium has been established.

AC ELECTRICAL CHARACTERISTICS(7)

$V_{CC} = 2.5V \pm 5\%$ or $3.3V \pm 10\%$; $T_A = -40^{\circ}C$ to $85^{\circ}C$, $R_L = 50\Omega$ to $V_{CC} - 2V$, unless otherwise stated.

Symbol	Parameter	Condition	Min	Typ	Max	Units
f_{MAX}	Maximum Operating Frequency	$V_{OUT} \geq 400mV$	4.5	5.5		GHz
t_{pd}	Differential Propagation Delay (IN0 or IN1-to-Q) (SEL-to-Q)		170	240	320	ps
			100	220	400	ps
Δt_{pd} Tempco	Differential Propagation Delay Temperature Coefficient			70		fs/°C
t_{SKEW}	Output-to-Output Part-to-Part	Note 8			20	ps
		Note 9			100	ps
t_{JITTER}	RMS Phase Jitter	Output: 622MHz Integration Range: 12kHz to 20MHz		50		fs
	Adjacent Channel Crosstalk-Induced Jitter	Note 10			0.7	ps _{rms}
t_r, t_f	Output Rise/Fall Time	Full Swing, 20% to 80%	35		110	ps

Notes:

7. High frequency AC electricals are guaranteed by design and characterization.
8. Output-to-output skew is measured between outputs under identical transitions.
9. Part-to-part skew is defined for two parts with identical power supply voltages at the same temperature and with no skew of the edges at the respective inputs.
10. Crosstalk is measured at the output while applying two similar clock frequencies that are asynchronous with respect to each other at the inputs.

PHASE NOISE

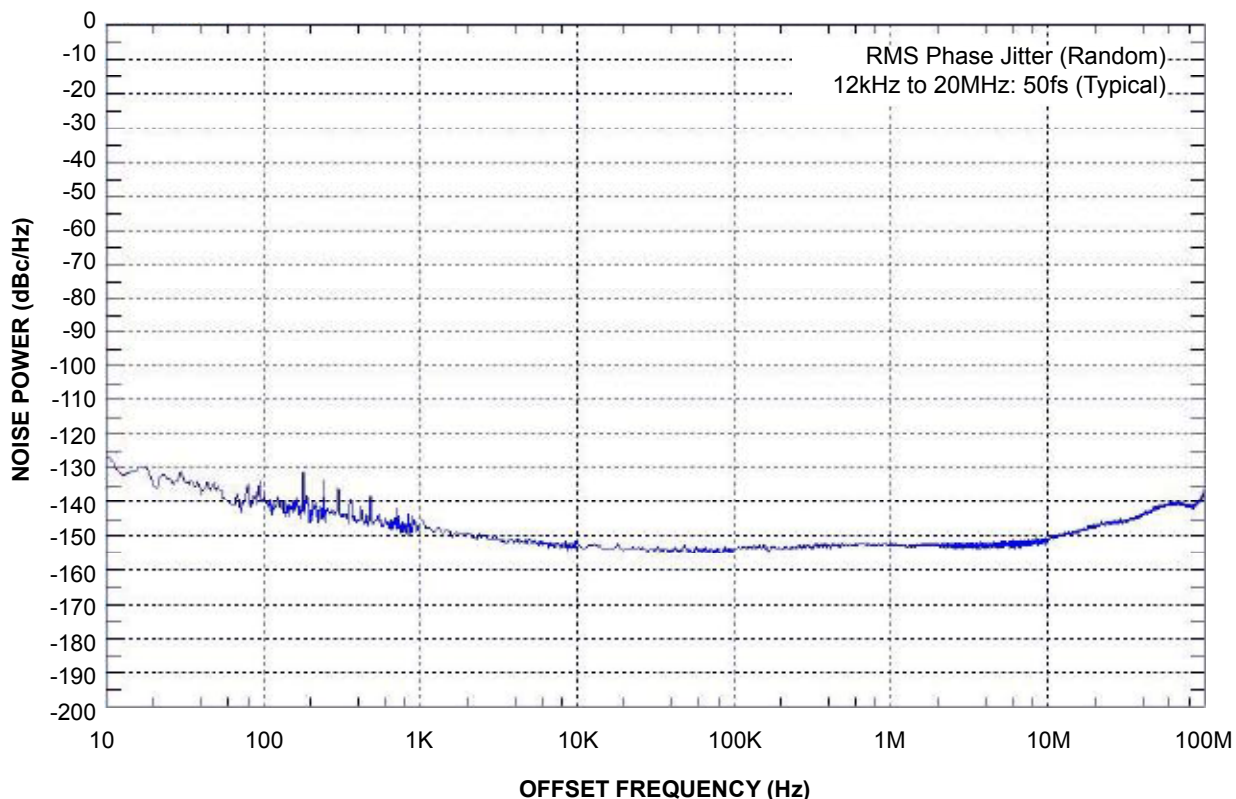

Phase Noise Plot: 622MHz @ 3.3V

SINGLE-ENDED AND DIFFERENTIAL SWINGS

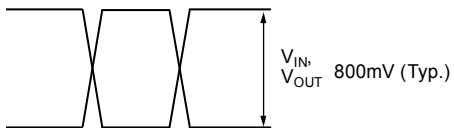

Figure 1a. Single-Ended Voltage Swing

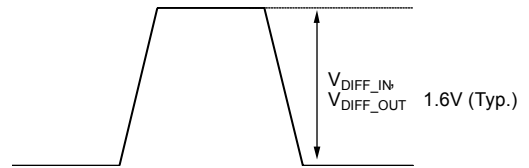
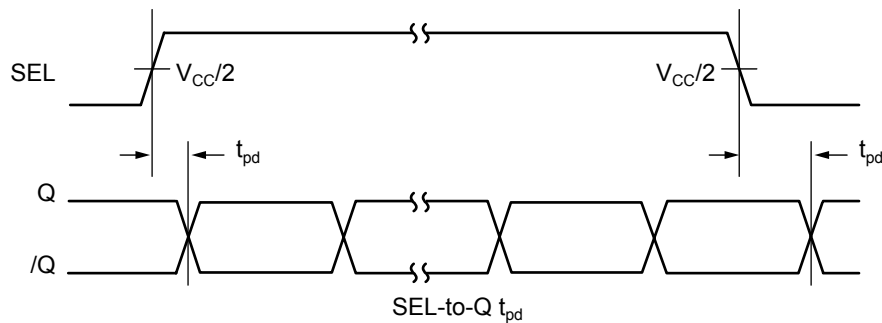
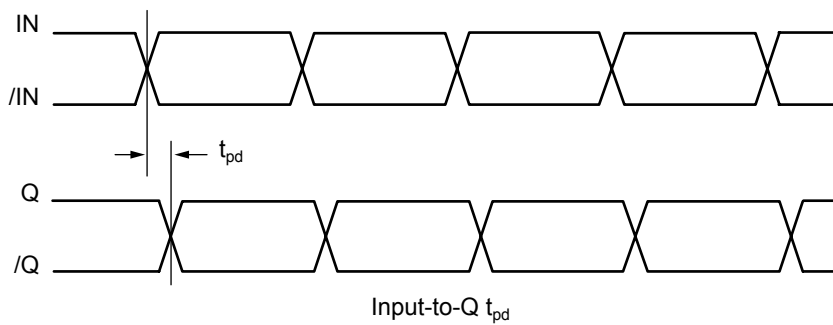

Figure 1b. Differential Voltage Swing

TIMING DIAGRAMS



TYPICAL OPERATING CHARACTERISTICS

$V_{CC} = 2.5V$, $GND = 0$, $V_{IN} = 100mV$, $R_L = 50\Omega$ to $V_{CC}-2V$; $T_A = 25^\circ C$, unless otherwise stated.

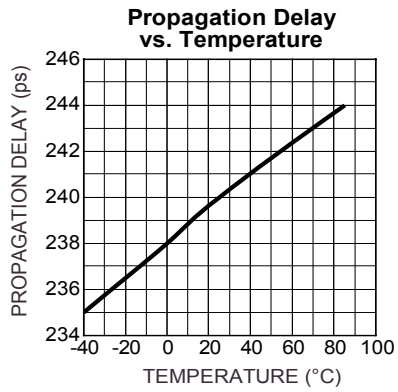
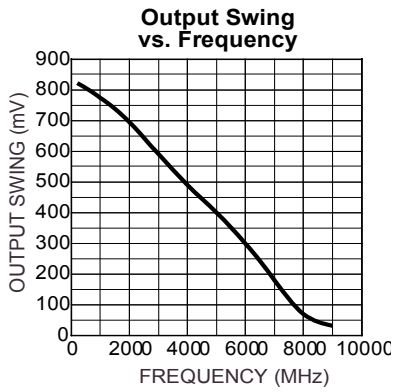

FUNCTIONAL CHARACTERISTICS

$V_{CC} = 3.3V$, $GND = 0$, $V_{IN} = 100mV$, $R_L = 50\Omega$ to $V_{CC}-2V$; $T_A = 25^\circ C$, unless otherwise stated.

200MHz Output

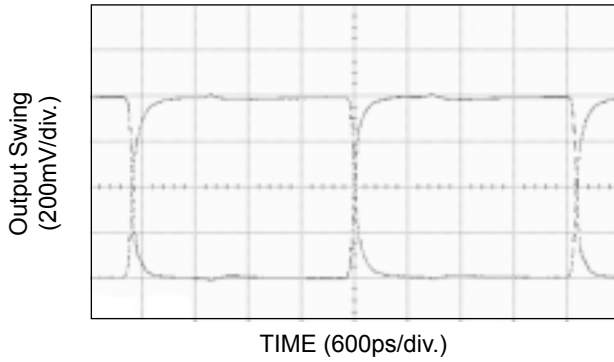

1.25GHz Output

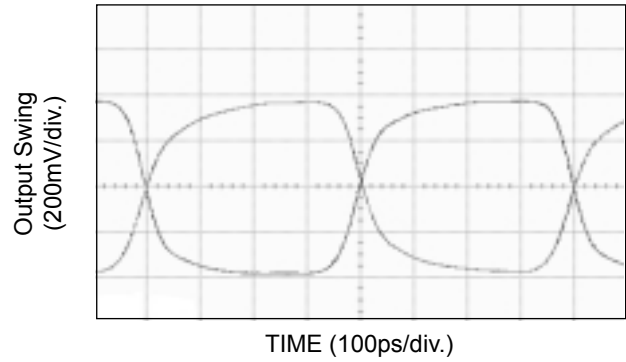

2.5GHz Output

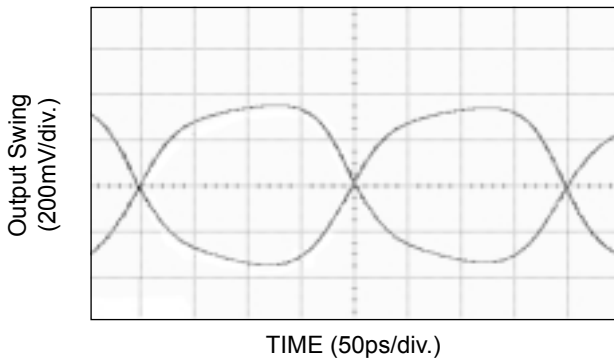

5GHz Output

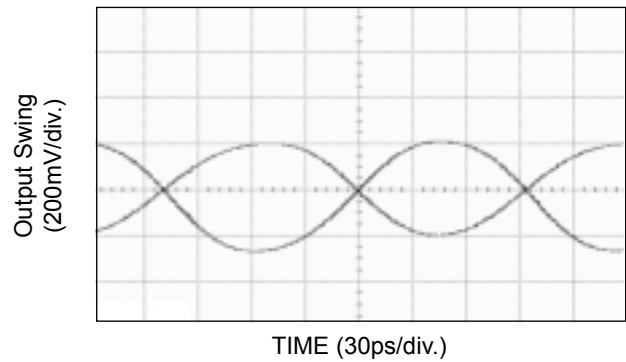

INPUT AND OUTPUT STAGES

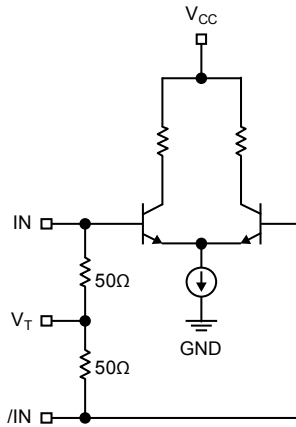

Figure 2a. Simplified Differential Input Stage

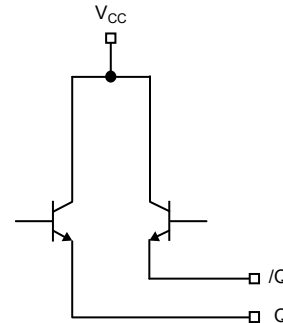

Figure 2b. Simplified LVPECL Output Stage

INPUT INTERFACE APPLICATIONS

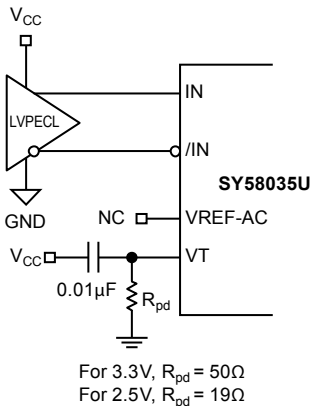

Figure 3a. LVPECL Interface (DC-Coupled)

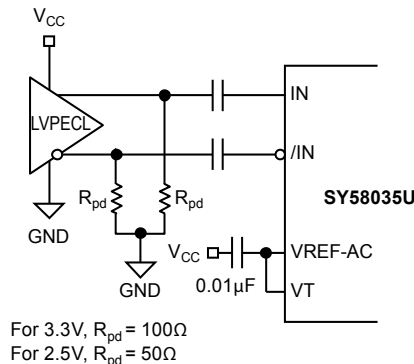

Figure 3b. LVPECL Interface (AC-Coupled)

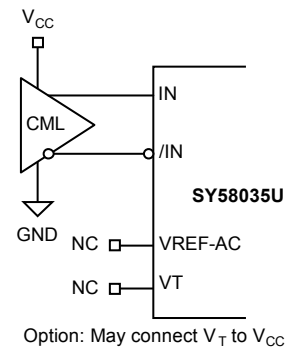

Figure 3c. CML Interface (DC-Coupled)

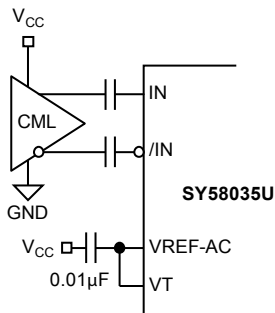

Figure 3d. CML Interface (AC-Coupled)

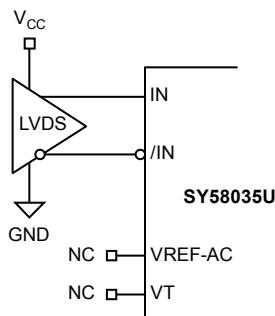

Figure 3e. LVDS Interface

OUTPUT INTERFACE APPLICATIONS

LVPECL has high input impedance, very low output (open emitter) impedance, and small signal swing, which results in low EMI. LVPECL is ideal driving 50Ω and 100Ω controlled impedance transmission lines. There are several techniques for terminating the LVECL output: parallel-thevenin equivalent

and parallel termination (3-resistor). Unused output pairs may be left floating. However, single-ended outputs must be terminated, or balanced.

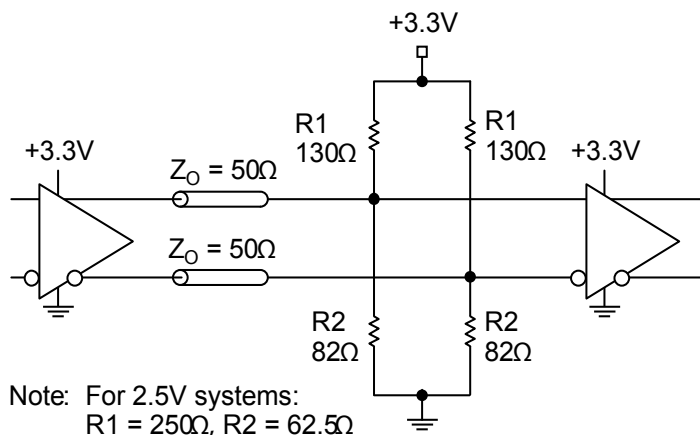

Figure 4a. Parallel Thevenin-Equivalent Termination

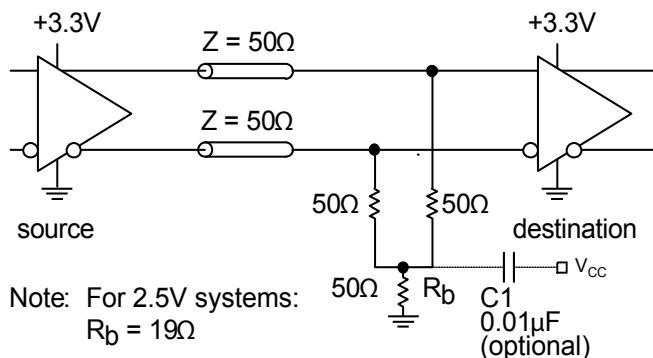
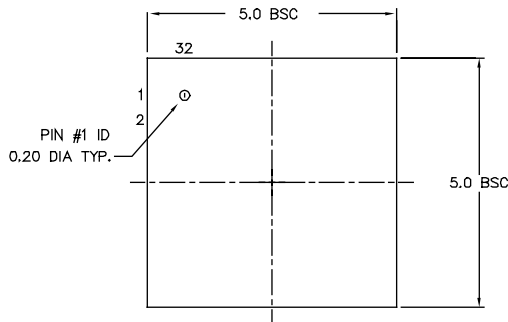

Figure 4b. Parallel Termination (3-Resistor)

RELATED MICREL PRODUCTS AND SUPPORT DOCUMENTATION

Part Number	Function	Data Sheet Link
SY58034U	6GHz, 1:6 CML Fanout Buffer with 2:1 MUX Input and Internal I/O Termination	http://www.micrel.com/product-info/products/sy58034u.shtml
SY58036U	6GHz, 1:6 400mV LVPECL Fanout Buffer with 2:1 MUX Input and Internal Termination	http://www.micrel.com/product-info/products/sy58036u.shtml
	MLF® Application Note	www.amkor.com/products/notes_papers/MLF_AppNote_0902.pdf
HBW Solutions	New Products and Applications	www.micrel.com/product-info/products/solutions.shtml

32-PIN MicroLeadFrame® (MLF-32)



TOP VIEW

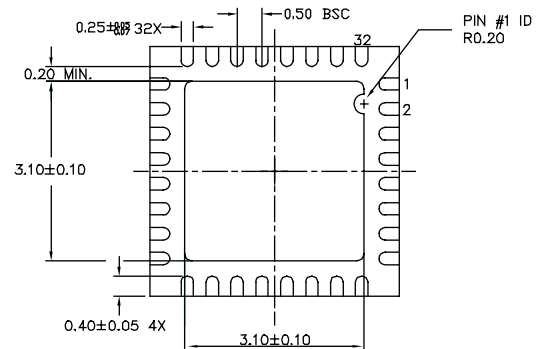

BOTTOM VIEW

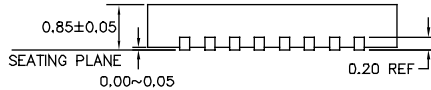

SIDE VIEW

- NOTE:
1. ALL DIMENSIONS ARE IN MILLIMETERS.
 2. MAX. PACKAGE WARPAGE IS 0.05 mm.
 3. MAXIMUM ALLOWABLE BURRS IS 0.076 mm IN ALL DIRECTIONS.
 4. PIN #1 ID ON TOP WILL BE LASER/INK MARKED.

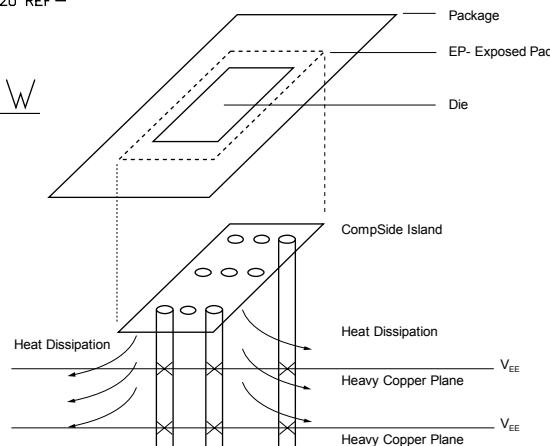

PCB Thermal Consideration for 32-Pin MLF® Package
(Always solder, or equivalent, the exposed pad to the PCB)

Package Notes:

1. Package meets Level 2 qualification.
2. All parts are dry-packaged before shipment.
3. Exposed pads must be soldered to a ground for proper thermal management.

MICREL, INC. 2180 FORTUNE DRIVE SAN JOSE, CA 95131 USA

TEL + 1 (408) 944-0800 FAX + 1 (408) 474-1000 WEB <http://www.micrel.com>

The information furnished by Micrel in this data sheet is believed to be accurate and reliable. However, no responsibility is assumed by Micrel for its use. Micrel reserves the right to change circuitry and specifications at any time without notification to the customer.

Micrel Products are not designed or authorized for use as components in life support appliances, devices or systems where malfunction of a product can reasonably be expected to result in personal injury. Life support devices or systems are devices or systems that (a) are intended for surgical implant into the body or (b) support or sustain life, and whose failure to perform can be reasonably expected to result in a significant injury to the user. A Purchaser's use or sale of Micrel Products for use in life support appliances, devices or systems is at Purchaser's own risk and Purchaser agrees to fully indemnify Micrel for any damages resulting from such use or sale.

© 2005 Micrel, Incorporated.

X-ON Electronics

Largest Supplier of Electrical and Electronic Components

Click to view similar products for [Buffers & Line Drivers](#) category:

Click to view products by [Microchip](#) manufacturer:

Other Similar products are found below :

[LXV200-024SW](#) [74AUP2G34FW3-7](#) [HEF4043BP](#) [PI74FCT3244L](#) [MC74HCT365ADTR2G](#) [Le87401NQC](#) [Le87402MQC](#) [028192B](#)
[042140C](#) [051117G](#) [070519XB](#) [NL17SZ07P5T5G](#) [NLU1GT126AMUTCG](#) [74AUP1G17FW5-7](#) [74LVC2G17FW4-7](#) [CD4502BE](#) [5962-](#)
[8982101PA](#) [5962-9052201PA](#) [74LVC1G125FW4-7](#) [NL17SH17P5T5G](#) [NL17SH125P5T5G](#) [NLV37WZ07USG](#) [74VHC541FT\(BE\)](#)
[RHRXH162244K1](#) [74AUP1G34FW5-7](#) [74AUP1G07FW5-7](#) [74LVC1G126FW4-7](#) [74LVC2G126RA3-7](#) [NLX2G17CMUTCG](#)
[74LVCE1G125FZ4-7](#) [Le87501NQC](#) [74AUP1G126FW5-7](#) [TC74HC4050AP\(F\)](#) [74LVCE1G07FZ4-7](#) [NLX3G16DMUTCG](#)
[NLX2G06AMUTCG](#) [NLVVHC1G50DFT2G](#) [LE87100NQC](#) [LE87290YQC](#) [LE87290YQCT](#) [LE87511NQC](#) [LE87511NQCT](#) [LE87557NQC](#)
[LE87557NQCT](#) [LE87614MQC](#) [LE87614MQCT](#) [74AUP1G125FW5-7](#) [NLU2G16CMUTCG](#) [MC74LCX244MN2TWG](#) [NL17SG126DFT2G](#)