



SY75576L

267MHz 1:4 3.3V HCSL/LVDS Fanout Buffer

PrecisionEdge™

General Description

The SY75576L is a high-speed, fully differential 1:4 clock fanout buffer optimized to provide four identical output copies with 137fs phase jitter and maximum 50ps output-to-output skew. Designed to be used with PCI-Express applications, SY75576L accepts and outputs HCSL or LVDS logic levels.

The SY75576L operates from a 3.3V $\pm 5\%$ power supply and is guaranteed over the full industrial temperature range (-40°C to $+85^{\circ}\text{C}$). It is available in a 20-pin TSSOP lead-free package.

The SY75576L is part of Micrel's high-speed, ultra-low jitter, PrecisionEdge™ product line.

Datasheets and support documentation are available on Micrel's web site at: www.micrel.com.

Functional Block Diagram

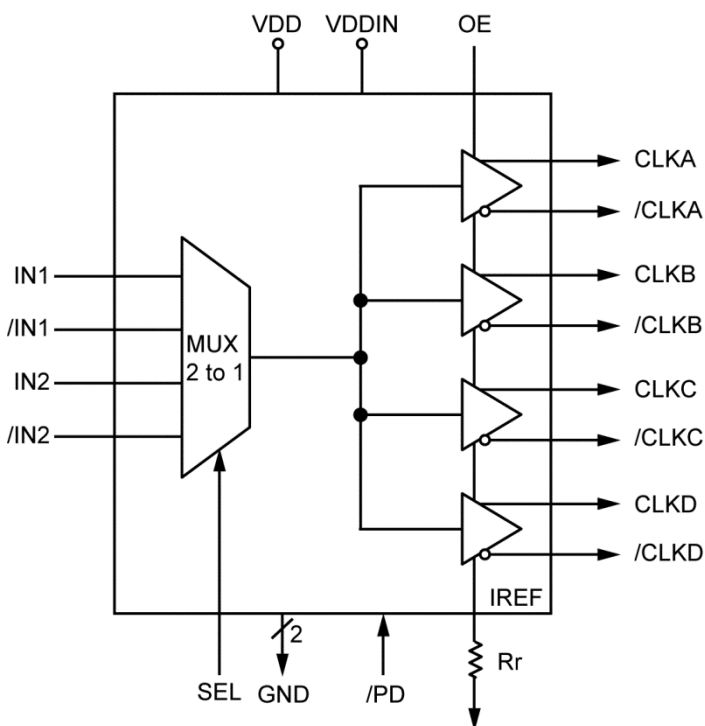

Features

- Four differential pairs of LVDS or HCSL outputs
- Two pairs of differential inputs accept LVDS or HCSL logic levels
- 267MHz max HCSL frequency
- 100MHz max LVDS frequency
- Ultra low phase jitter:
 - 137fs_{rms}, 200MHz (12kHz–20MHz)
 - 153fs_{rms}, 156.25MHz (12kHz–20MHz)
 - 212fs_{rms}, 100MHz (12kHz–20MHz)
- <2ps Total_Jitter_{pk-pk}, 200MHz (BER = 10⁻¹²)
- 50ps output-to-output skew
- 3.3V $\pm 5\%$ power supply operation
- -40°C to $+85^{\circ}\text{C}$ operating temperature
- Available in 20-pin TSSOP lead-free package

Applications

- Clock distribution
- PCI-Express
- Servers
- Switches
- Routers

Precision Edge is a registered trademark of Micrel, Inc.

Micrel Inc. • 2180 Fortune Drive • San Jose, CA 95131 • USA • tel +1 (408) 944-0800 • fax +1 (408) 474-1000 • <http://www.micrel.com>

July 2, 2013

Revision 1.0
hbwhelp@micrel.com or (408) 955-1690

Ordering Information⁽¹⁾

Part Number	Package Type	Operating Range	Package Marking	Lead Finish
SY75576LKY	TSSOP-20	Industrial	75576L with Pb-Free bar-line indicator	Matte-Sn
SY75576LKY TR ⁽²⁾	TSSOP-20	Industrial	75576L with Pb-Free bar-line indicator	Matte-Sn

Notes:

1. Contact factory for die availability. Dice are guaranteed at T_A = 25°C, DC Electricals only.
2. Tape and Reel.

Pin Configuration

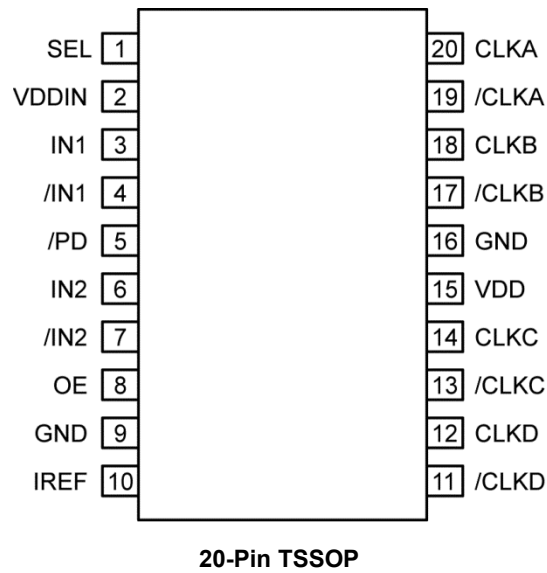

Pin Description

Pin Number	Pin Name	Pin Function
1	SEL	SEL = 0 propagates IN2, /IN2 to outputs. SEL = 1 propagates IN1, /IN1 to outputs. Internal pull-up resistor, IN1, /IN1 is selected by default.
2	VDDIN	3.3V power supply
3	IN1	HCSSL/LVDS input 1
4	/IN1	HCSSL/LVDS inverted input 1
5	/PD	PD = 0 powers down the chip and tri-states outputs. The pin is attached to an internal pull-up resistor.
6	IN2	HCSSL/LVDS input 2
7	/IN2	HCSSL/LVDS inverted input 2
8	OE	Tri-state outputs. High = enable outputs. Low = disable outputs. Internal pull-up resistor, outputs are enabled by default.
9	GND	Ground
10	IREF	External resistor Rref between pin IREF and GND controls reference current
11	/CLKD	Inverted output D
12	CLKD	Non-inverted output D
13	/CLKC	Inverted output C
14	CLKC	Non-inverted output C
15	VDD	3.3V power supply
16	GND	Ground
17	/CLKB	Inverted output B
18	CLKB	Non-inverted output B
19	/CLKA	Inverted output A
20	CLKA	Non-inverted output A

Clock Input Function Table

SEL	Input Pair
0	IN2 / $\overline{\text{IN2}}$
1	IN1 / $\overline{\text{IN1}}$

Absolute Maximum Ratings⁽³⁾

Supply Voltage (V_{DD}, V_{DDIN})	5.5V
Input Voltage (V_{IN})	-0.5V to $V_{DDIN} + 0.5V$
Lead Temperature (soldering, 20s)	260°C
Maximum Junction Temperature	125°C
Storage Temperature (T_s)	-65°C to +150°C
ESD Protection (input)	2000V min.

Operating Ratings⁽⁴⁾

Supply Voltage (V_{DD}, V_{DDIN})	3.135V to 3.465V
Ambient Op Temperature (T_A)	-40°C to +85°C
Package Thermal Resistance ⁽⁵⁾	
TSSOP	
Still-air (θ_{JA})	93°C/W
Junction-to-Case (θ_{JC})	20°C/W

DC Electrical Characteristics⁽⁶⁾

$V_{DD} = V_{DDIN} = 3.135V$ to $3.465V$, $T_A = -40^\circ C$ to $+85^\circ C$, unless otherwise stated. $R_{ref} = 475\Omega$

Symbol	Parameter	Condition	Min.	Typ.	Max.	Units
V_{DD}, V_{DDIN}	Power Supply Voltage Range		3.135	3.3	3.465	V
C_{IN}	Input Capacitance				7	pF
C_{out}	Output Capacitance				6	pF
L_{Pin}	Pin Inductance				5	nH
R_{out}	Output Resistance		3			k Ω
$R_{pull\ up}$	Pull up Resistance	SEL, /PD, OE		110		k Ω
V_{IH}	Input High Voltage	SEL, /PD, OE	2		$V_{DDIN} + 0.3$	V
V_{IL}	Input Low Voltage	SEL, /PD, OE	-0.3		0.8	V
V_{IH}	Input High Voltage	HCSSL, IN, /IN	660	750	850	V
V_{IL}	Input Low Voltage	HCSSL, IN, /IN	-150	0		V
V_{IN}	Differential Input Voltage Range	LVDS, IN, /IN	250	350	550	mV
$V_{input\ offset}$	Input Common Mode Voltage	LVDS, IN, /IN,	1.125	1.25	1.375	V
V_{OH}	Output High Voltage	HSCL	660	750	850	mV
V_{OL}	Output Low Voltage	HSCL	-150	0	27	mV
$V_{cross}^{(7, 8)}$	Crossing Point Voltage	Absolute	250	350	550	mV
$V_{cross_variation}^{(7, 8, 9)}$	Variation of Crossing Point Voltage	Variation over all edges			140	mV
I_{DD}	Power Supply Current For $V_{DD} + V_{DDIN}$	50 Ω , 2pF		75	90	mA
		No load, /PD = Low			0.4	mA
		OE = Logic Low			20	mA
$I_{IL}^{(10)}$	Input Leakage Current	$0 < V_{IN} < V_{DDIN}$	-5		5	μA

Notes:

- Permanent device damage may occur if absolute maximum ratings are exceeded. This is a stress rating only and functional operation is not implied at conditions other than those detailed in the operational sections of this datasheet. Exposure to absolute maximum ratings conditions for extended periods may affect device reliability.
- The datasheet limits are not guaranteed if the device is operated beyond the operating ratings.
- Package thermal resistance assumes that the exposed pad is soldered (or equivalent) to the device's most negative potential on the PCB. ψ_{JB} and θ_{JA} values are determined for a 4-layer board in still-air unless otherwise stated. The circuit is designed to meet the DC specifications shown in the above table after thermal equilibrium has been established.
- The circuit is designed to meet the DC specifications shown in the above table after thermal equilibrium has been established.
- Test setup is $R_L = 50\Omega$ with 2pF, $R_r = 475\Omega \pm 1\%$.
- Measurement taken from Q and /Q.
- Measured at the crossing point where instantaneous voltages of CLK and /CLK are equal.
- Inputs with pull-up/pull-down resistances are not included.

AC Electrical Characteristics⁽⁶⁾

$V_{DD} = V_{DDIN} = 3.135V$ to $3.465V$, $T_A = -40^{\circ}C$ to $+85^{\circ}C$, unless otherwise stated.

Symbol	Parameter	Condition	Min.	Typ.	Max.	Units
f_{MAX}	Maximum Frequency	HCSL Termination			267	MHz
		LVDS Termination			100	MHz
t_{PD}	Propagation Delay	Note 11		2		ns
t_{Skew}	Output-to-Output skew	Notes 12, 13			50	ps
t_R, t_F	Output Rise/Fall Times 0.175V to 0.525V / 0.525V to 0.175V	At full output swing. 50Ω, 2pF	175	338	700	ps
t_{R/F_var}	Rise/Fall Time Variation	At full output swing. 50Ω, 2pF			125	ps
T_{RJ_jitter}	Phase Jitter	At 200MHz		137		fs _{rms}
		At 156.25MHz		153		fs _{rms}
		At 100MHz		212		fs _{rms}
T_{TJ_jitter}	Total Jitter	BER = 10^{-12} , $T_{DJ} = 0$, at 200MHz		2		ps
T_{OE_enable}	Output Enable Time	All Outputs		2		μs
$T_{OE_disable}$	Output Disable Time	All Outputs		10		ns
T_{DCY}	Duty Cycle		45	50	55	%

Notes:

- Measured from the differential input crossing point to the differential output crossing point.
- Output-to-Output skew is the difference in time between outputs, receiving data from the same input, for the same temperature, voltage, and transition.
- This parameter is defined in accordance with JEDEC Standard 65.

Jitter Analysis

Jitter is defined as the deviation of a signal from its ideal position. Phase noise is the presence of signal energy at frequencies other than the carrier. Random jitter has a Gaussian distribution and is specified as an rms unit, which is one standard deviation of the distribution. Since Gaussian distribution is unbounded in an infinite sample, no communication system can be completely error free. Instead, communication links are rated with a maximum bit error rate (BER), which is typically around 10^{-12} for high-speed communication equipment. Achieving a desired BER requires accounting for a number of standard deviations of random noise by using the appropriate value for N (see Table 1) in the formula in Equation 1.

$$T_j = N \times R_j + D_j \quad \text{Eq. 1}$$

Where T_j is total jitter, R_j is random jitter, and D_j is deterministic jitter. If routing clock signals, the deterministic jitter is usually negligible and the T_j is dominated by the random jitter. Calculating T_j from R_j using Equation 1 gives the values in Table 1.

Table 1. Standard Deviations of Random Noise

BER	N	R_j at 200MHz	T_j at 200MHz
10^{-10}	12.723	137fs _{rms}	1.743ps
10^{-11}	13.412	137fs _{rms}	1.837ps
10^{-12}	14.069	137fs _{rms}	1.927ps
10^{-13}	14.698	137fs _{rms}	2.013ps

Phase Noise Plots

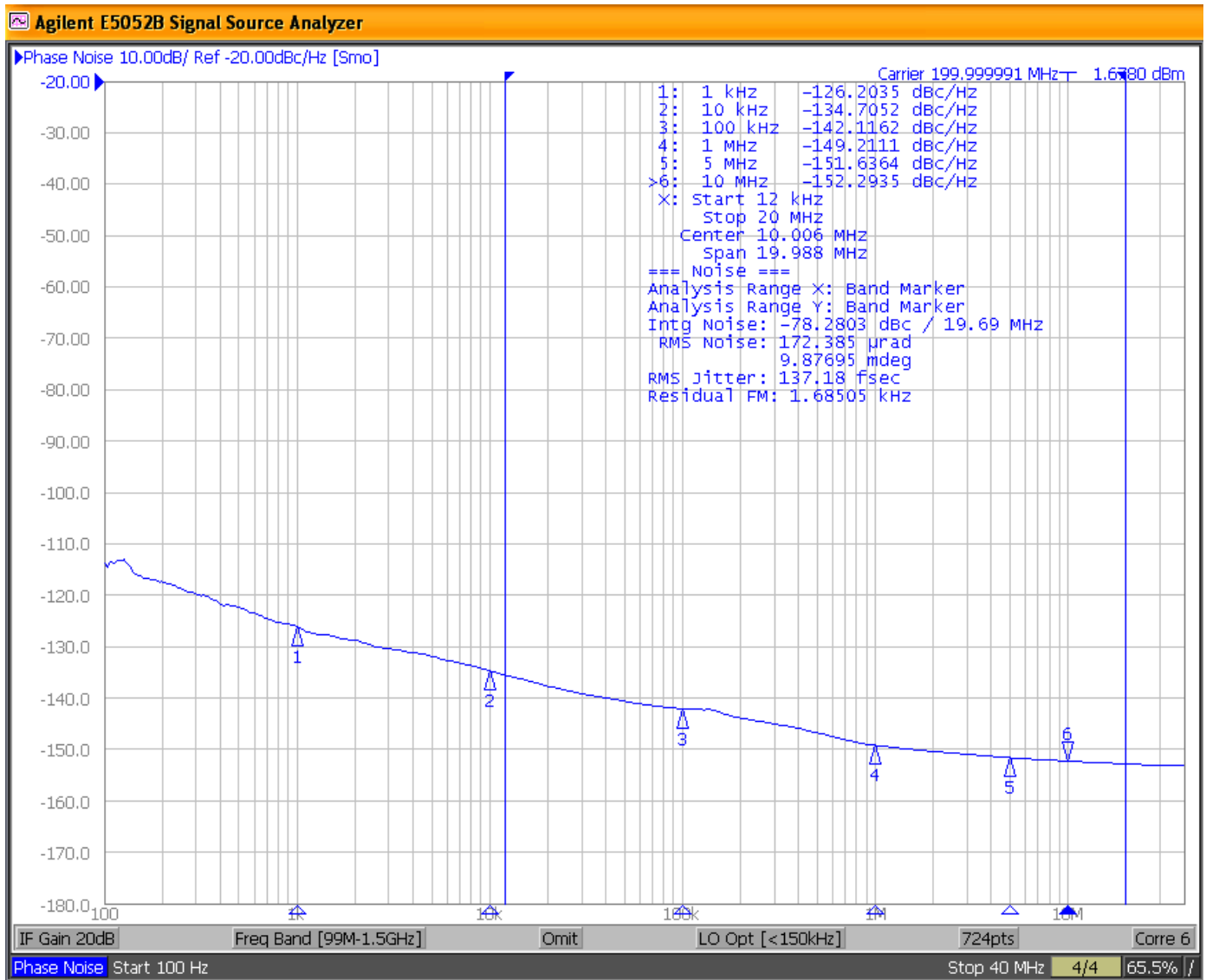

Phase jitter = 137fs_{rms}, 200MHz carrier frequency; integration range: 12kHz–20MHz

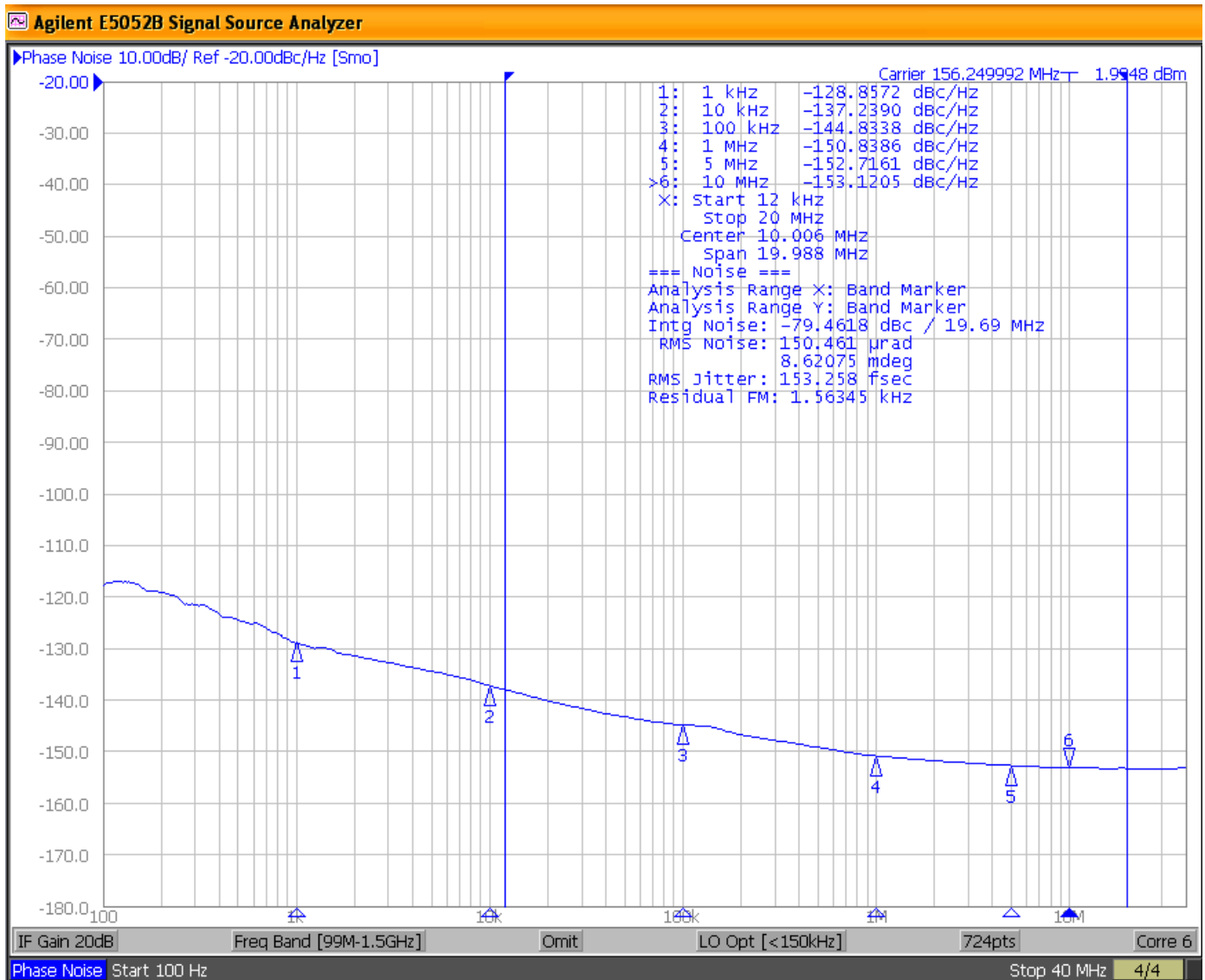

Phase jitter = 153fs_{rms}, 156.25MHz carrier frequency; integration range: 12kHz–20MHz

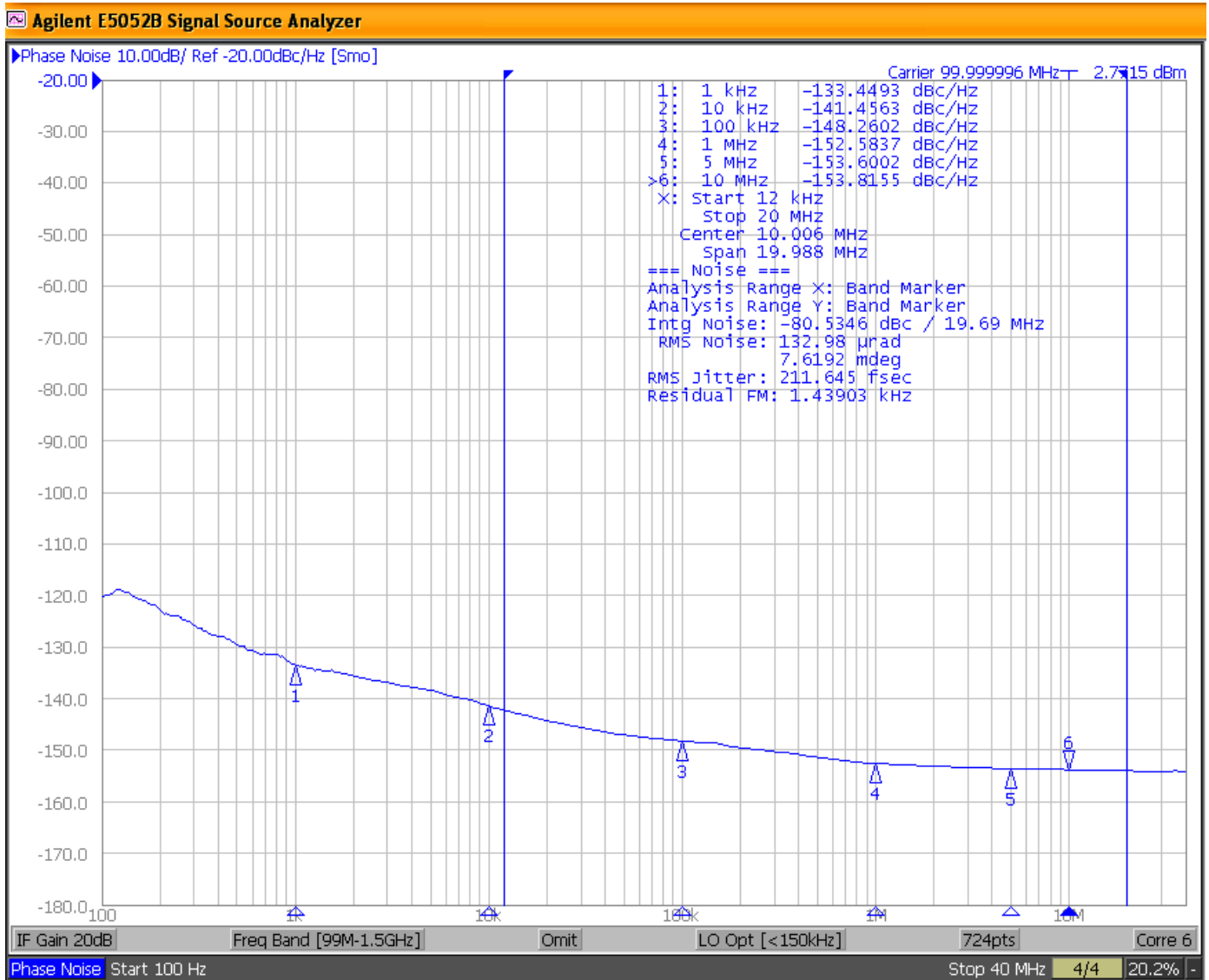

Phase jitter = 212fs_{rms}, 100MHz carrier frequency; integration range: 12kHz–20MHz

Functional Characteristics

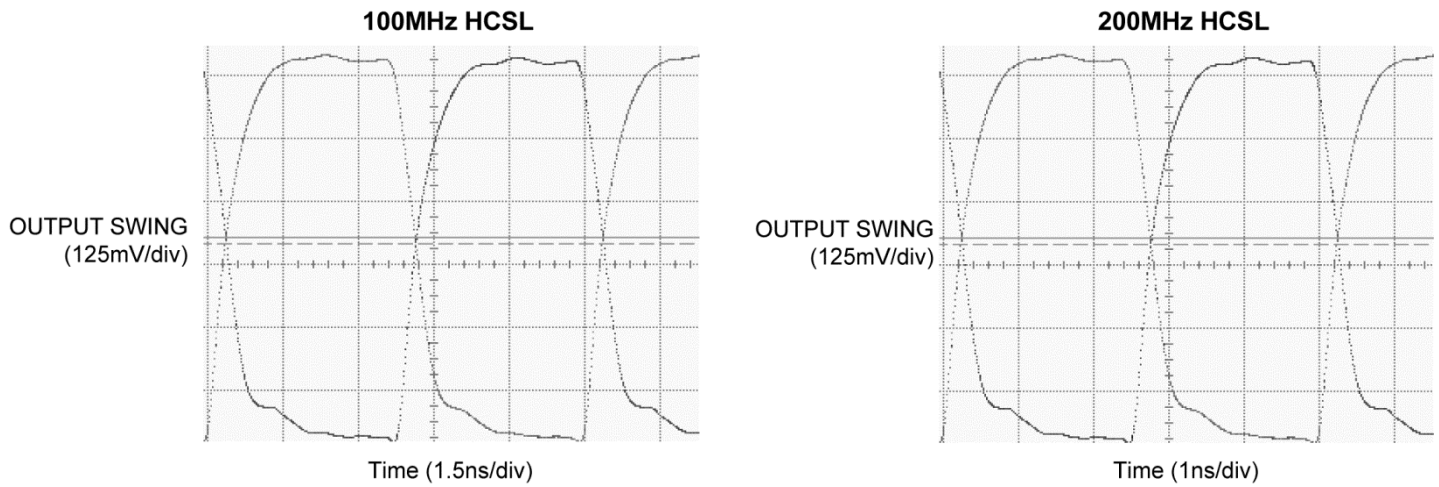

HCSL Waveform Diagram

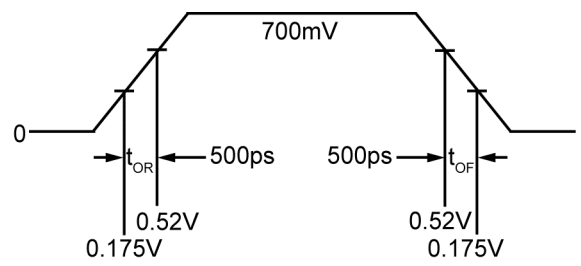

HCSL Interface Application

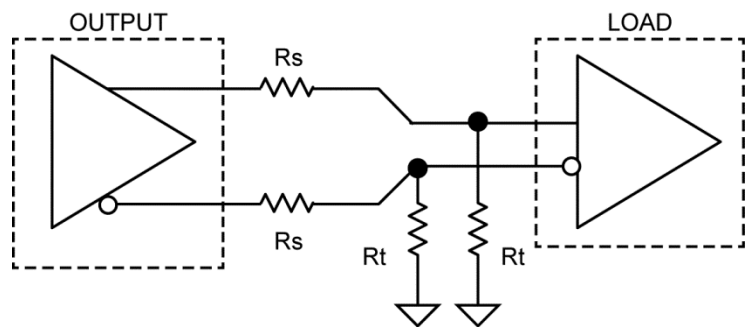

PCI-Express Device Routing

$R_s = 33\Omega$
 $R_t = 50\Omega$

LVDS Waveform Diagram

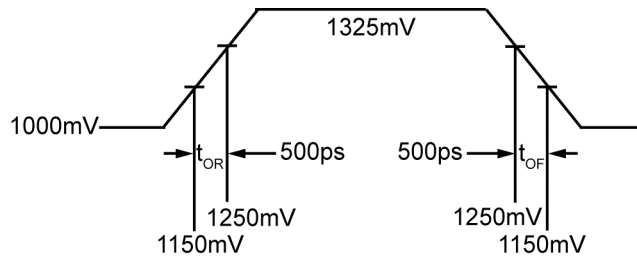

LVDS Interface Application

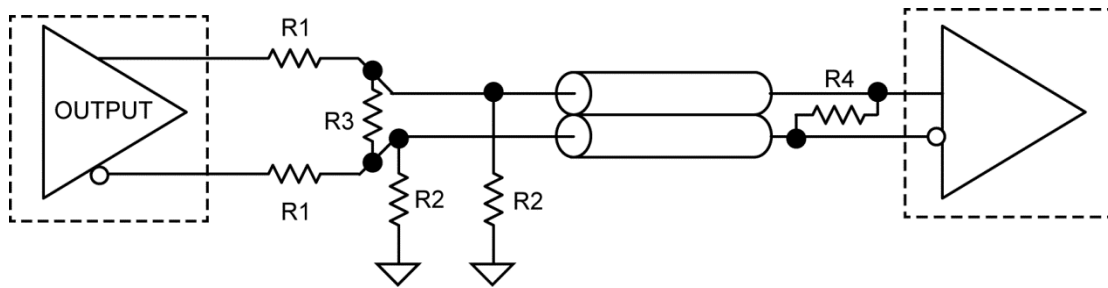

- R1 = 33Ω
- R2 = 175Ω
- R3 = 140Ω
- R4 = 100Ω

Package Information⁽¹⁴⁾

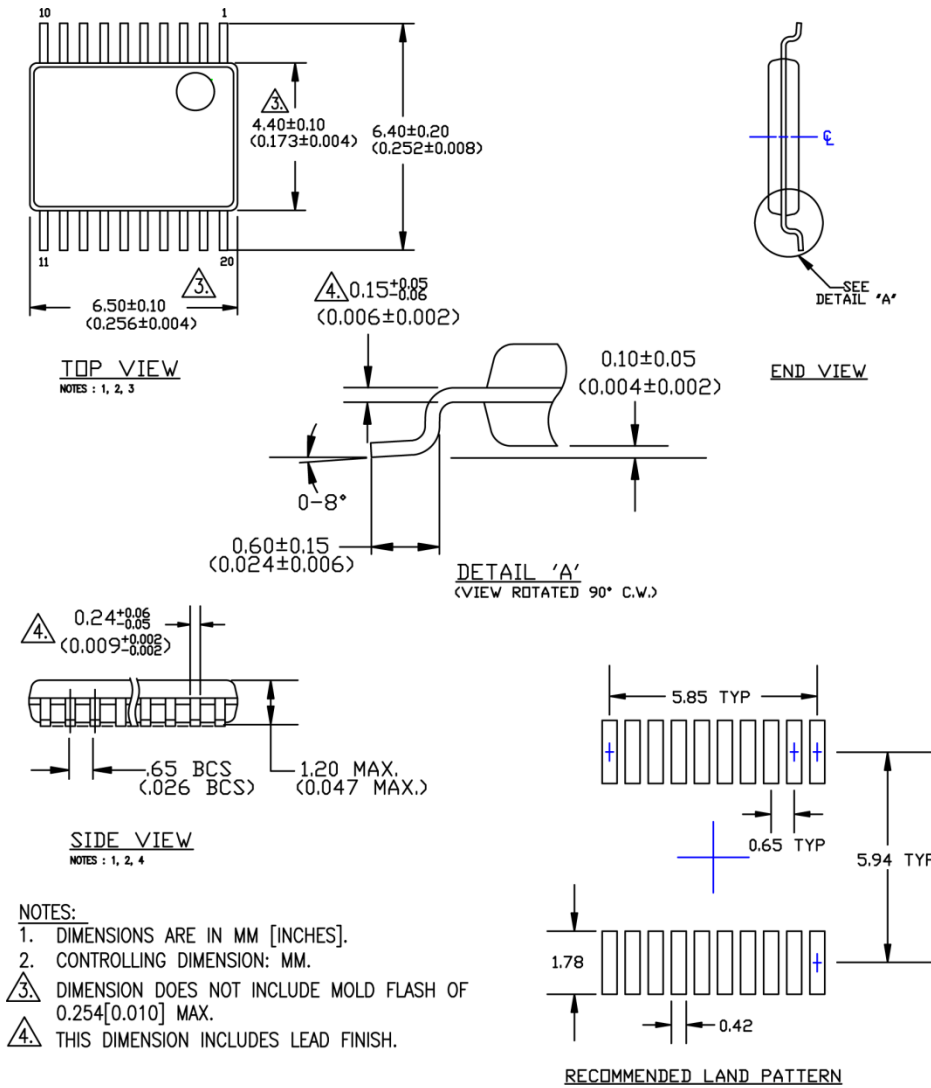

- NOTES:**
1. DIMENSIONS ARE IN MM [INCHES].
 2. CONTROLLING DIMENSION: MM.
 3. DIMENSION DOES NOT INCLUDE MOLD FLASH OF 0.254[0.010] MAX.
 4. THIS DIMENSION INCLUDES LEAD FINISH.

20-Pin TSSOP

Note:

14. Package information is correct as of the publication date. For updates and most current information, go to www.micrel.com.

MICREL, INC. 2180 FORTUNE DRIVE SAN JOSE, CA 95131 USA
 TEL +1 (408) 944-0800 FAX +1 (408) 474-1000 WEB <http://www.micrel.com>

Micrel makes no representations or warranties with respect to the accuracy or completeness of the information furnished in this data sheet. This information is not intended as a warranty and Micrel does not assume responsibility for its use. Micrel reserves the right to change circuitry, specifications and descriptions at any time without notice. No license, whether express, implied, arising by estoppel or otherwise, to any intellectual property rights is granted by this document. Except as provided in Micrel's terms and conditions of sale for such products, Micrel assumes no liability whatsoever, and Micrel disclaims any express or implied warranty relating to the sale and/or use of Micrel products including liability or warranties relating to fitness for a particular purpose, merchantability, or infringement of any patent, copyright or other intellectual property right.

Micrel Products are not designed or authorized for use as components in life support appliances, devices or systems where malfunction of a product can reasonably be expected to result in personal injury. Life support devices or systems are devices or systems that (a) are intended for surgical implant into the body or (b) support or sustain life, and whose failure to perform can be reasonably expected to result in a significant injury to the user. A Purchaser's use or sale of Micrel Products for use in life support appliances, devices or systems is a Purchaser's own risk and Purchaser agrees to fully indemnify Micrel for any damages resulting from such use or sale.

X-ON Electronics

Largest Supplier of Electrical and Electronic Components

Click to view similar products for [Clock Buffer](#) category:

Click to view products by [Microchip](#) manufacturer:

Other Similar products are found below :

[MPC962309EJ-1H](#) [NB4N121KMNG](#) [IDT49FCT805ASO](#) [MK2308S-1HILF](#) [PL133-27GI-R](#) [NB3L02FCT2G](#) [NB3L03FCT2G](#)
[ZL40203LDG1](#) [ZL40200LDG1](#) [ZL40205LDG1](#) [9FG1200DF-1LF](#) [9FG1001BGLF](#) [PI49FCT20802QE](#) [NB7L1008MNG](#) [NB7L14MN1G](#)
[PI49FCT20807QE](#) [PI6C4931502-04LIEX](#) [ZL80002QAB1](#) [PI6C4931504-04LIEX](#) [PI6C10806BLEX](#) [ZL40226LDG1](#) [ZL40219LDG1](#)
[8T73S208B-01NLGI](#) [SY75578LMG](#) [PI49FCT32805QEX](#) [PL133-27GC-R](#) [CDCV304PWG4](#) [MC10LVEP11DG](#) [MC10EP11DTG](#)
[MC100LVEP11DG](#) [MC100E111FNG](#) [MC100EP11DTG](#) [NB7L14MMNG](#) [NB6L11MMNG](#) [NB6L14MMNR2G](#) [NB6L611MNG](#)
[NB3N111KMNR4G](#) [ADCLK944BCPZ-R7](#) [ZL40217LDG1](#) [NB7LQ572MNG](#) [HMC940LC4BTR](#) [ADCLK946BCPZ-REEL7](#)
[ADCLK946BCPZ](#) [ADCLK905BCPZ-R2](#) [ADCLK905BCPZ-R7](#) [ADCLK907BCPZ-R2](#) [ADCLK907BCPZ-WP](#) [ADCLK914BCPZ-R2](#)
[ADCLK914BCPZ-R7](#) [ADCLK925BCPZ-R2](#)