

FEATURES

- Up to 2.5Gbps operation
- 30mA modulation current
- Separate modulation control
- Separate output enable for laser safety
- Differential inputs for data
- 75K Ω input pull-down resistor
- 3.3V and 5V power supply options
- Available in a tiny 10-pin (3mm x 3mm) MSOP

APPLICATIONS

- 1.25Gbps and 2.5Gbps Gigabit Ethernet
- 531Mbps, 1062Mbps and 2.12Gbps Fibre Channel
- 622Mbps SONET
- Gigabit Interface Converter
- 2.5Gbps SDH/SONET
- 2.5Gbps Proprietary Links

DESCRIPTION

The SY88922V is a high-speed current switch for driving a semiconductor laser diode in optical transmission applications. The modulation current (I_{OUT}) is controlled by the current (I_{RSET}) through the external resistor R_{SET} . The output OUT is HIGH when output enable is HIGH.

The device incorporates complementary open collector outputs with a capability of driving peak current of 30mA. The resistor R_{EXT} must be placed between /OUT and V_{CC} to dissipate the worst case power. R_{SER} is recommended to compensate for laser diode matching issues. Pin 9 and pin 10 should be connected to achieve better performance.

The SY88922V utilizes the high-performance bipolar ASSET™ technology.

All support documentation can be found on Micrel's web site at www.micrel.com.

BLOCK DIAGRAM

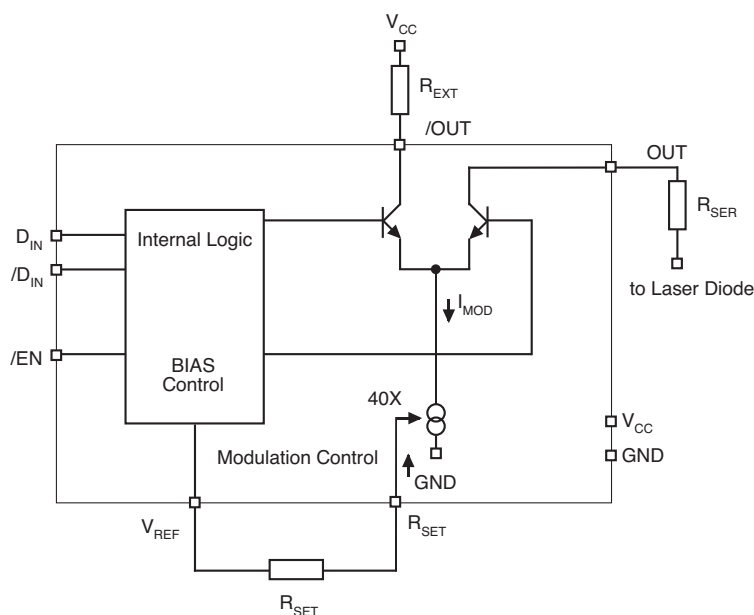

PACKAGE/ORDERING INFORMATION

Ordering Information⁽¹⁾

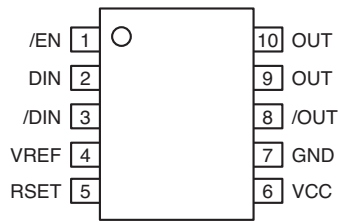

10-Pin MSOP (K10-1)

Part Number	Package Type	Operating Range	Package Marking	Lead Finish
SY88922VKC	K10-1	Commercial	SY88922V	Sn-Pb
SY88922VKCTR ⁽²⁾	K10-1	Commercial	SY88922V	Sn-Pb
SY88922VKG	K10-1	Industrial	SY88922V with Pb-Free bar-line indicator	Pb-Free NiPdAu
SY88922VKGTR ⁽²⁾	K10-1	Industrial	SY88922V with Pb-Free bar-line indicator	Pb-Free NiPdAu

Notes:

1. Contact factory for die availability. Die is guaranteed at T_A = 25°C, DC electricals only.
2. Tape and Reel.

PIN DESCRIPTION

Pin Number	Pin Name	Pin Function
1	/EN	Enable. This PECL 100k compatible input enables Laser Driver. Modulation current goes to zero when asserted HIGH.
2, 3	DIN, /DIN	Differential PECL 100k compatible inputs which receive NRZ data.
4	VREF	Voltage reference for use with R _{SET} .
5	RSET	An external resistor sets up the source current for modulation I _{MOD} .
6	VCC	Most positive power supply input.
7	GND	Ground.
8, 9, 10	/OUT, OUT	Open collector outputs from the modulation buffer drive these differential current outputs.

TRUTH TABLE⁽¹⁾

D	/D	/EN	OUT ⁽²⁾	/OUT
L	H	L	H	L
H	L	L	L	H
X	X	H	H	L

Notes:

1. L = LOW, H = HIGH, X = don't care.
2. H = I_{OUT} = 0mA.

Absolute Maximum Ratings⁽¹⁾

Supply Voltage (V_{CC})	+0V to +7.0V
Input Voltage (V_{IN})	0 to V_{CC}
Output Current (V_{OUT})	30mA
Power Dissipation (P_D)	250mW
Lead Temperature (soldering, 20 sec.)	260°C
Maximum Operating Junction Temperature (T_J)	+125°C
Storage Temperature (T_S)	-55°C to +125°C

Operating Ratings⁽²⁾

Supply Voltage (V_{CC})	+4.5V to +5.5V or +3.0V to +3.6V
Ambient Temperature (T_A)	-40°C to +85°C
Capacitance on OUT + /OUT (C_{OUT})	2.5pF (typ.)
Resistor to Dissipate Power (R_{EXT})	10 to 50Ω
Laser Diode Serial Resistor (R_{SER})	0 to 50Ω
Resistor to Adjust Current (R_{SET}) ⁽⁴⁾	700 to 20,000Ω
Package Thermal Resistance ⁽³⁾	
MSOP (θ_{JA}) Still-air	113°C/W
MSOP (Ψ_{JB})	74°C/W

DC ELECTRICAL CHARACTERISTICS

GND = 0V; $V_{CC} = +5.0V \pm 10\%$ or $V_{CC} = +3.3V \pm 10\%$; $T_A = -40^\circ C$ to $+85^\circ C$; unless noted.

Symbol	Parameter	Condition	Min	Typ	Max	Units
V_{IH}	Input HIGH Voltage ($D_{IN}, /D_{IN}, /EN$)		$V_{CC} - 1165$		$V_{CC} - 880$	mV
V_{IL}	Input LOW Voltage ($D_{IN}, /D_{IN}, /EN$)		$V_{CC} - 1810$		$V_{CC} - 1475$	mV
V_{REF}	Reference Voltage		1.7	2.0	2.3	V
I_{IL}	Input LOW Current ($D_{IN}, /D_{IN}, /EN$) ⁽⁵⁾		0.5			μA
I_{IH}	Input HIGH Current ($D_{IN}, /D_{IN}, /EN$)				100	μA
I_{CC}	Supply Current ⁽⁶⁾				25	mA
I_{OL}	Output LOW Current ($/EN = HIGH$)			450	1000	μA
I_{OUT}	Modulation Current				30	mA
I_{RSET}	Modulation Control		0.125		0.625	mA
A_{RSET}	$= I_{OUT} / I_{RSET}$		30	38	44	—

Notes:

1. Permanent device damage may occur if Absolute Maximum Ratings are exceeded. This is a stress rating only and functional operation is not implied at conditions other than those detailed in the operational sections of this data sheet. Exposure to Absolute Maximum Ratings conditions for extended periods may affect device reliability.
2. The voltage drop across R_{EXT} and R_{SER} plus Laser Diode should not be greater than 1V.
3. Still-air without heatsink.
4. R_{SET} minimum 430Ω.
5. $V_{IN} = V_{IL}$ (min).
6. $I_{MOD} = 25mA$.

AC ELECTRICAL CHARACTERISTICS⁽⁷⁾

$I_{MOD} = 10\text{mA}$; $GND = 0\text{V}$; $V_{CC} = +5\text{V} \pm 10\%$ or $V_{CC} = +3.3\text{V} \pm 10\%$; $T_A = -40^\circ\text{C}$ to $+85^\circ\text{C}$; unless noted.

Symbol	Parameter	Condition	Min	Typ	Max	Units
$t_{pd\ D}$	Propagation Delay (D _{IN} – OUT)			400		ps
$t_{pd\ EN}$	Propagation Delay (/EN – OUT)			400		ps
t_r, t_f	Rise/Fall Time ⁽⁸⁾ (20% to 80%)			74	130	ps
I_{OR}	Output Current Ringing ⁽⁹⁾				10	%
D_J	Deterministic Jitter ⁽¹⁰⁾			7		ps _{rms}

Notes:

7. $R_{EXT} = R_{SER} = 25\Omega \pm 1\%$; R_{SER} connects to V_{CC} directly without Laser Diode.
8. $I_{MOD} = 10\text{mA}$.
9. $I_{OH} = 5$ to 25mA .
10. $I_{MOD} = 10\text{mA}$, 2.5Gbps, $2^{23}-1$ pattern.

TYPICAL CHARACTERISTICS

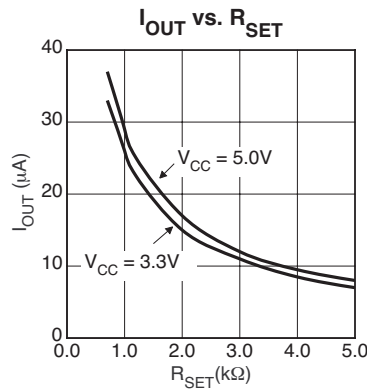

10-PIN MSOP (K10-1)

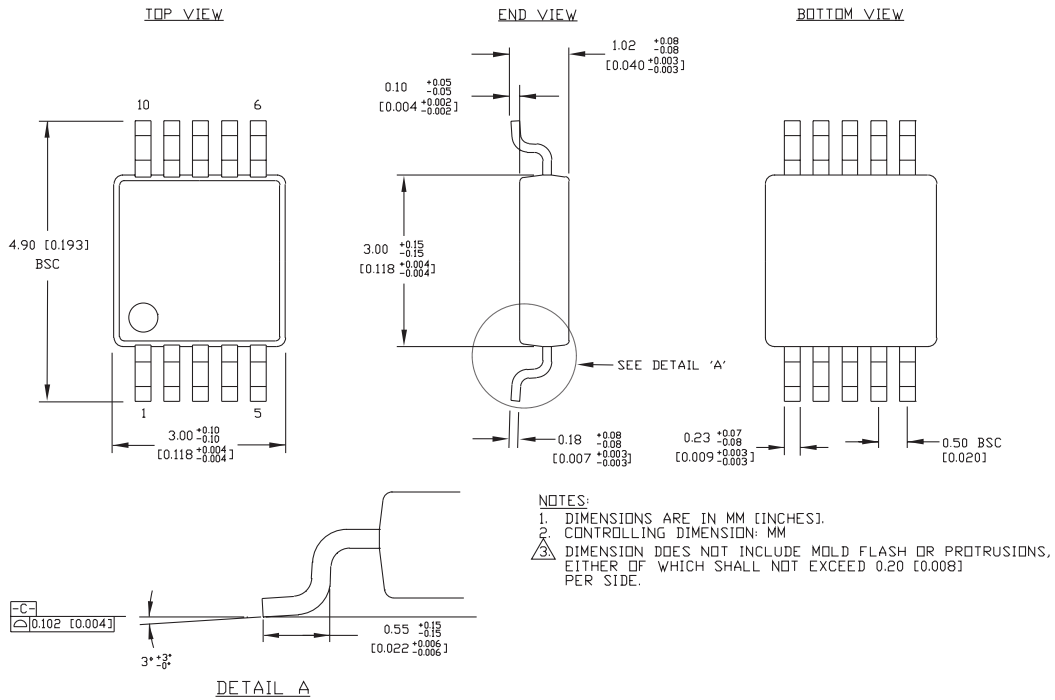

Rev. 00

MICREL, INC. 2180 FORTUNE DRIVE SAN JOSE, CA 95131 USA

TEL + 1 (408) 944-0800 FAX + 1 (408) 474-1000 WEB <http://www.micrel.com>

The information furnished by Micrel in this data sheet is believed to be accurate and reliable. However, no responsibility is assumed by Micrel for its use. Micrel reserves the right to change circuitry and specifications at any time without notification to the customer.

Micrel Products are not designed or authorized for use as components in life support appliances, devices or systems where malfunction of a product can reasonably be expected to result in personal injury. Life support devices or systems are devices or systems that (a) are intended for surgical implant into the body or (b) support or sustain life, and whose failure to perform can be reasonably expected to result in a significant injury to the user. A Purchaser's use or sale of Micrel Products for use in life support appliances, devices or systems is at Purchaser's own risk and Purchaser agrees to fully indemnify Micrel for any damages resulting from such use or sale.

© 2005 Micrel, Incorporated.

X-ON Electronics

Largest Supplier of Electrical and Electronic Components

Click to view similar products for [Laser Drivers](#) category:

Click to view products by [Microchip](#) manufacturer:

Other Similar products are found below :

[AXXSATADVDRWROM937575 937575](#) [ADN2872ACPZ](#) [AD9665ACPZ-REEL7](#) [ADN2830ACPZ32](#) [ADN2841ACPZ-48](#) [ADN2847ACPZ-32](#) [ADN2871ACPZ](#) [ADN2841ACPZ-32](#) [HMC7144LC4](#) [HMC7144LC4TR](#) [HMC7150LP3DE](#) [HMC7810ALC3](#) [DS1873T+](#) [DS1874T+](#) [MAX3740AETG+T](#) [MAX3643ETG+T](#) [MAX3646ETG+T](#) [MAX3949ETE+T](#) [MAX3869ETJ](#) [DS1863E](#) [SY88422LMG](#) [MAX3669EHJ](#) [SY84782UMG](#) [SY88022ALMG](#) [SY88992LMG](#) [SY88432LMG-TR](#) [SY88432LMG](#) [ONET1151LRGET](#) [ONET1151PRGTT](#) [ONET4201LDRGER](#) [ONET4201LDRGET](#) [ONET4211LDRGET](#) [ONET1101LRGER](#) [ONET1151LRGER](#) [ONET8501VRGPT](#) [MAX3948ETE](#) [MAX24002TL+](#) [DS1864T+](#) [DS1862B](#) [LTC5100EUF#PBF](#) [DS1862AB+](#) [MAX3656ETG+T](#) [LMH6525SP/NOPB](#) [LMH6526SPNOPB](#) [ONET1141LRGET](#)