



# 3.3V, 2.7Gbps SDH/SONET LASER DRIVER WITH AUTOMATIC POWER CONTROL

SY88952L

## FEATURES

- Single 3.3V power supply
- Up to 2.7Gbps operation
- Rise/Fall times: < 75ps
- Independent programmable laser modulation and bias currents
- Bias current to 100mA and modulation current to 90mA
- Automatic average laser power control
- Bias and modulation current monitors
- Operating temperature range of  $-40^{\circ}\text{C}$  to  $+85^{\circ}\text{C}$
- Complies with ANSI, ITU, and Bellcore SDH/SONET specifications
- Available in DIE form and 32-pin (5mm x 5mm) EPAD-MLF™ package

## APPLICATIONS

- OC-48 transceivers and transponders
- SONET/SDH transmission system
- Add drop mux
- Metro area network
- 2.5Gbps optical transmitter
- Fiber optical module

## DESCRIPTION

SY88952L is a highly integrated and programmable laser driver for SONET/SDH application up to 2.7Gbps. The device accepts differential PECL or LVDS data and clock inputs. It provides programmable bias and modulation currents for driving a laser. The modulation output of SY88952L can be DC-coupled to drive the laser diode, providing a significant power saving over AC-coupled operation. A synchronizing TTL input latch can be used to reduce jitter if a clock signal is available. A TTL enable is also incorporated in the device. EN only enables/disables  $I_{\text{MOD}}$ . It does not enable/disable  $I_{\text{BIAS}}$ .

An automatic power controller (APC) is integrated into SY88952L to maintain a constant average optical output power over temperature and lifetime. The modulation current can be externally temperature compensated to minimize the variation of extinction ratio of the optical output.

Several safety features will enable an alarm function when the output signal is too high, or bias current is too high.

There are two alarm conditions:

1. /FAIL asserts when bias current loop goes to maximum of it's range.  $I_{\text{BIAS}}$  and  $I_{\text{MOD}}$  still flow under this condition.

2. /FAIL asserts when  $I_{\text{BIASMAX}}$  or  $I_{\text{MODSET}}$  are too high (implying  $I_{\text{BIAS}}$  or  $I_{\text{MOD}}$  will be too high). All currents will shut off under this condition.

**PACKAGE/ORDERING INFORMATION**

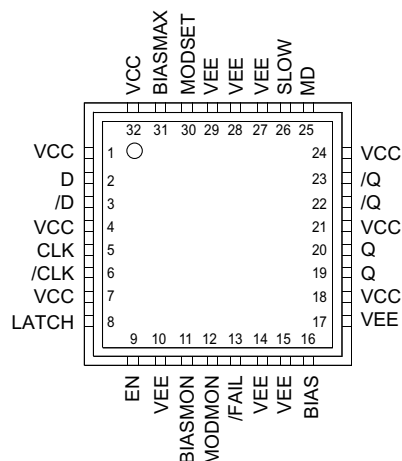

**32-Pin MLF™ (MLF-32)**

**Ordering Information<sup>(1)</sup>**

Part Number	Package Type	Operating Range	Package Marking	Lead Finish
SY88952LMI	MLF-32	Industrial	SY88952L	Sn-Pb
SY88952LMITR <sup>(2)</sup>	MLF-32	Industrial	SY88952L	Sn-Pb
SY88952LMG	MLF-32	Industrial	SY88952L with Pb-Free bar-line indicator	Pb-Free NiPdAu
SY88952LMGTR <sup>(2)</sup>	MLF-32	Industrial	SY88952L with Pb-Free bar-line indicator	Pb-Free NiPdAu

**Notes:**

1. Dice are designed to operate from -40°C to +85°C, but are tested and guaranteed to T<sub>A</sub> = +25°C only.
2. Tape and Reel.

**PIN DESCRIPTION**

Pin Number	Pin Name	Pin Function
16	BIAS	Bias Current Output (I <sub>BIAS</sub> ).
11	BIASMON	Bias Current Monitor: Sinks current that is proportional to I <sub>BIAS</sub> , (I <sub>BIAS</sub> /40). An external current path must exist to V <sub>CC</sub> .
31	BIASMAX	A resistor (R <sub>BIASMAX</sub> ) connected to ground sets the maximum bias current. See "Typical Operating Characteristics" (I <sub>BIAS</sub> vs. R <sub>BIASMAX</sub> ).
26	SLOW	Connect a capacitor (C <sub>SLOW</sub> ) to ground to provide a slow-start.
5, 6	CLK,/CLK	Differential Clock Input. 75kΩ pull-down on CLK, 75kΩ pull-up and 75kΩ pull-down on /CLK.
2, 3	D, /D	Differential Data Input. 75kΩ pull-down on D, 75kΩ pull-up and 75kΩ pull-down on /D.
9	EN	TTL Input with 75kΩ pull-up: Default HIGH for normal operation; LOW to disable modulation current.
8	LATCH	TTL Input with 75kΩ pull-up: Default HIGH for latched (clocked) data; LOW for direct data.
25	MD	Connect this pin to a monitor photodiode anode, a resistor (R <sub>APCSET</sub> ) and a capacitor (C <sub>APCSET</sub> ). This sets the desired average optical power.
19, 20, 22, 23	Q, /Q	Differential Output: Modulation current output (I <sub>MOD</sub> ).
12	MODMON	Modulation Current Monitor: Sinks current that is proportional to I <sub>MOD</sub> , (I <sub>MOD</sub> /45). An external current path must exist to V <sub>CC</sub> .
30	MODSET	A resistor (R <sub>MODSET</sub> ) connected to ground sets the modulation current. See "Typical Operating Characteristics" (I <sub>MOD</sub> vs. R <sub>MODSET</sub> ).
13	/FAIL	TTL Open-Collector Output: Connect a 5kΩ resistor to V <sub>CC</sub> . Indicates APC failure when LOW.
1, 4, 7, 18, 21, 24, 32	VCC	Positive Power Supply.
10, 14, 15, 17, 27, 28, 29, EP	VEE	Device Ground: Ensure the exposed pad is also connected to ground.

**TRUTH TABLE<sup>(1)</sup>**

D	/D	EN	OUT <sup>(2)</sup>	/OUT
L	H	H	H	L
H	L	H	L	H
X	X	L	H	L

- Note 1.** L = LOW, H = HIGH, X = don't care.  
**Note 2.** H = I<sub>OUT</sub> ≤ I<sub>MOD\_OFF</sub>.

### Absolute Maximum Ratings<sup>(1)</sup>

Supply Voltage ( $V_{CC}$ )	+0V to +7.0V
Input Voltage ( $V_{IN}$ )	+0V to $V_{CC}$
Output Current ( $I_{OUT}$ )	100mA
Lead Temperature (soldering, 10 sec.)	300°C
Storage Temperature ( $T_S$ )	-65°C to +150°C

### Operating Ratings<sup>(2, 3)</sup>

Supply Voltage ( $V_{CC}$ )	+3.0V to +3.6V
Ambient Temperature ( $T_A$ )	-40°C to +85°C
Junction Temperature ( $T_J$ )	120°C
Package Thermal Resistance	
MLF™	
( $\theta_{JA}$ ) still-air	34°C/W
( $\psi_{JB}$ ) still-air	19°C/W

## DC ELECTRICAL CHARACTERISTICS

$V_{CC} = 3.0V$  to  $3.6V$ ;  $V_{EE} = GND$ ;  $R_{LOAD} = 5\Omega$ ;  $T_A = -40^\circ C$  to  $+85^\circ C$

Symbol	Parameter	Condition	Min	Typ	Max	Units
$I_{CC}$	Supply Current	<b>Note 4</b>			85	mA
$I_{BIAS}$	Bias Current Range	<b>Note 5</b>	1		100	mA
$I_{MOD}$	Modulation Current Range	<b>Note 5</b>	1		90	mA
$I_{MOD\_OFF}$	Modulation Off Current	<b>Note 6</b>			750	$\mu A$
$V_{ID}$	Differential Input Voltage		200		1600	mV <sub>PP</sub>
$V_{ICMR}$	Common Mode Range		$V_{CC} - 1.49$		$V_{CC} - V_{ID}/4$	V
$V_{IH}$	TTL Input HIGH Voltage		2.0		$V_{CC}$	V
$V_{IL}$	TTL Input LOW Voltage				0.8	V
$V_{OL}$	/FAIL Output LOW Voltage	<b>Note 6</b>			0.5	V
$I_{OH}$	/FAIL Output Leakage Current	<b>Note 7</b>			100	$\mu A$

**Notes:**

1. Permanent device damage may occur if absolute maximum ratings are exceeded. This is a stress rating only and functional operation is not implied at conditions other than those detailed in the operational sections of this data sheet. Exposure to absolute maximum rating conditions for extended periods may affect device reliability.
2. The data sheet limits are not guaranteed if the device is operated beyond the operating ratings.
3. Devices are ESD sensitive. Handling precautions recommended.
4. Excluding actual  $I_{BIAS}$  and  $I_{MOD}$  output currents.
5. Voltage at Q, /Q must not drop below  $V_{CC} - 1.5V$ . Voltage BIAS, MODMON and BIASMON must not drop below  $V_{CC} - 2V$ .
6. EN = LOW.
7.  $I_{OL} = +2mA$ .
8.  $V_{OH} = 3.6V$ .

**AC ELECTRICAL CHARACTERISTICS<sup>(9)</sup>**

$V_{CC} = 3.0V$  to  $3.6V$ ;  $V_{EE} = GND$ ;  $T_A = -40^{\circ}C$  to  $+85^{\circ}C$ ; typical values @  $V_{CC} = 3.3V$ ,  $T_A = 25^{\circ}C$ ,  $I_{MOD} = 40mA$ ,  $I_{BIAS} = 50mA$ ,  $R_{LOAD} = 5\Omega$

Symbol	Parameter	Condition	Min	Typ	Max	Units
CID	Maximum Consecutive Identical Digits		80			bits
PWD	Pulse Width Distortion	<b>Note 10, 11</b>			50	ps
$t_S$	Latch Set-Up Time		40			ps
$t_H$	Latch Hold Time		40			ps
$t_r, t_f$	Output Rise/Fall Time (20% to 80%)				75	ps

**Notes:**

- 9. AC characteristics are guaranteed by design and characterization.
- 10. Measured with 622Mbps 0-1 pattern, latch = HIGH.
- 11. PWD = (Wider pulse – narrower pulse) /2.

**TIMING DIAGRAM**

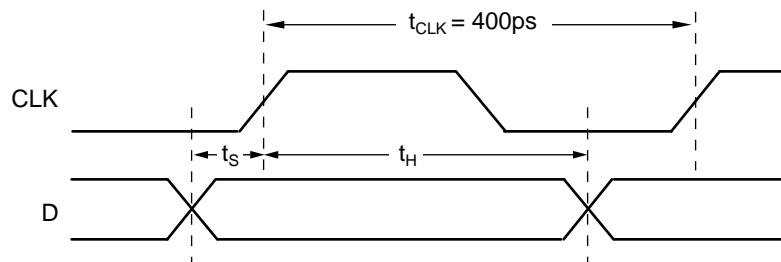

**Setup/Hold Time Definition**

**TYPICAL OPERATING CHARACTERISTICS(NOTE 1)**

$V_{CC} = 3.3V$ ,  $T_A = 25^\circ C$ , unless otherwise stated.

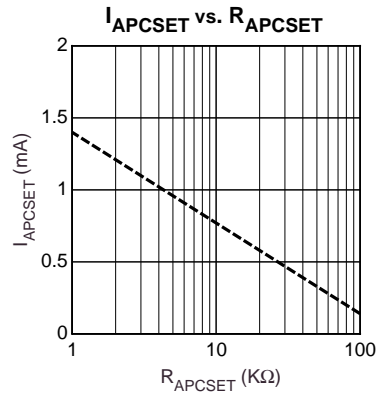
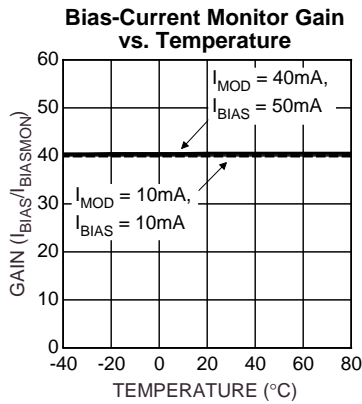
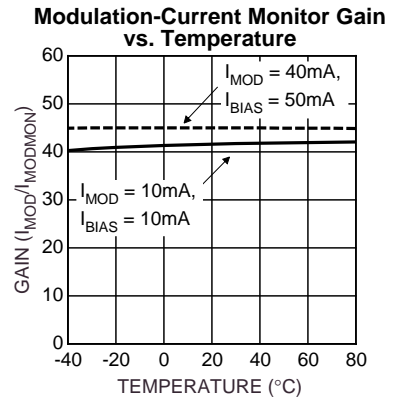
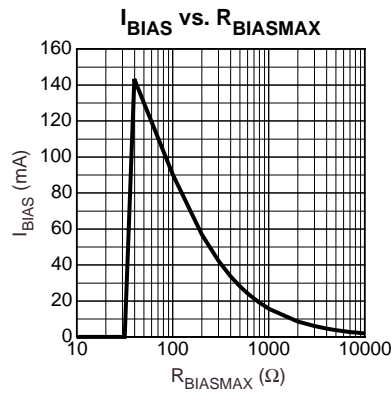
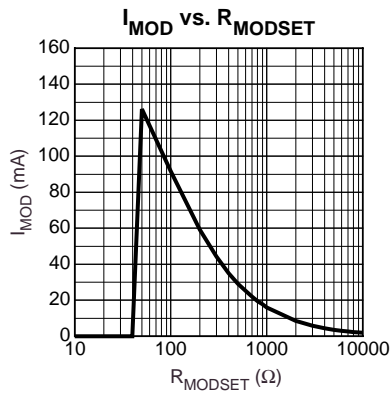

**Note 1.**  $I_{BIAS}$  and  $I_{MOD}$  must never exceed 100mA and 90mA, respectively.

**BLOCK DIAGRAM**

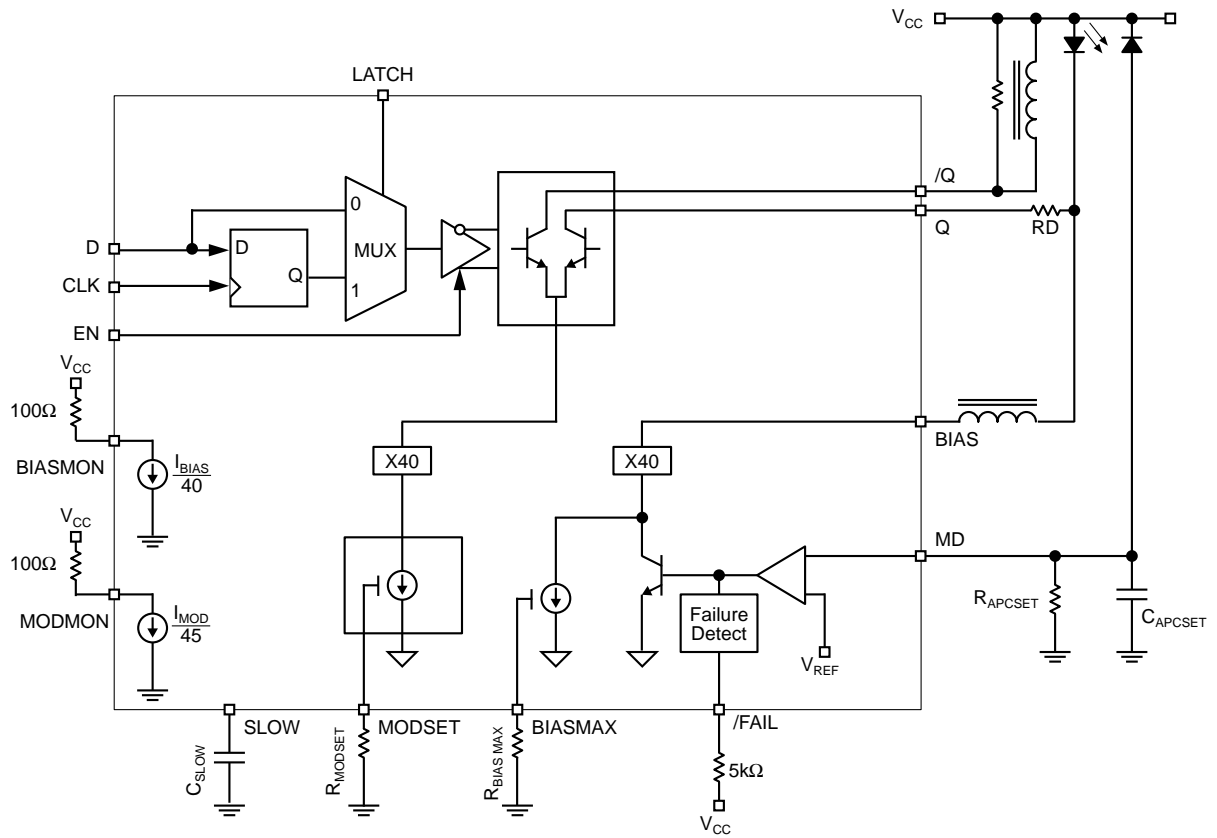

**32 LEAD EPAD-Micro LEADFRAME™ (MLF-32)**

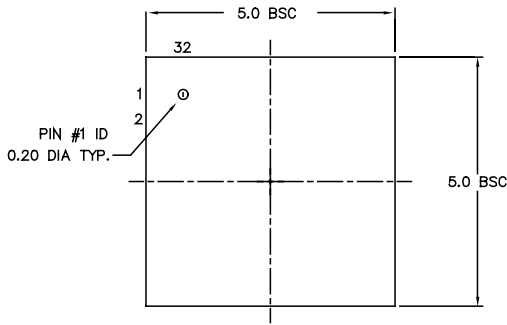

TOP VIEW

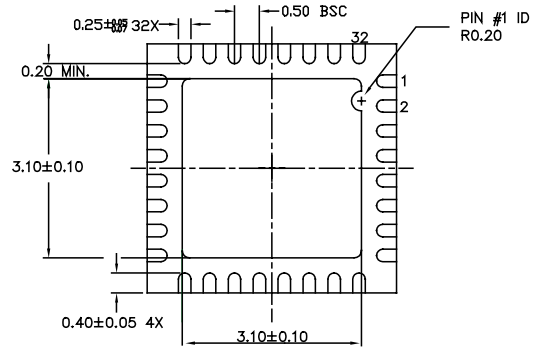

BOTTOM VIEW

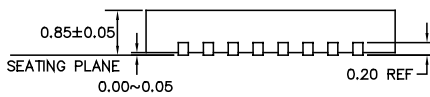

SIDE VIEW

- NOTE:
1. ALL DIMENSIONS ARE IN MILLIMETERS.
  2. MAX. PACKAGE WARPAGE IS 0.05 mm.
  3. MAXIMUM ALLOWABLE BURRS IS 0.076 mm IN ALL DIRECTIONS.
  4. PIN #1 ID ON TOP WILL BE LASER/INK MARKED.

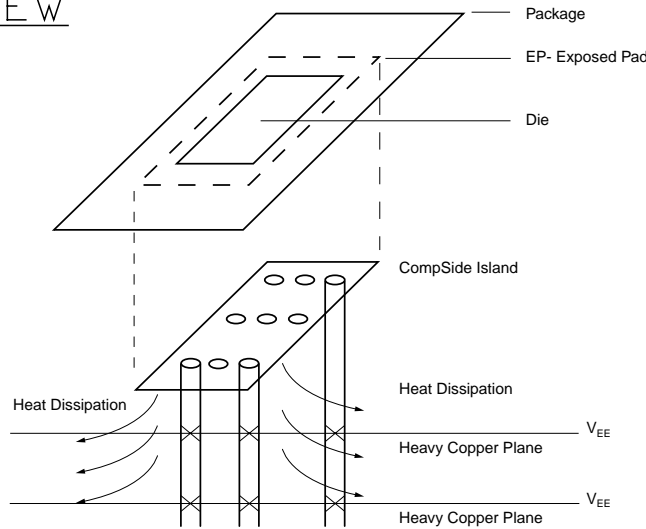

**PCB Thermal Consideration for 32-Pin MLF™ Package  
(Always solder to equivalent or PCB)**

**MICREL, INC. 2180 FORTUNE DRIVE SAN JOSE, CA 95131 USA**

TEL + 1 (408) 944-0800 FAX + 1 (408) 474-1000 WEB <http://www.micrel.com>

The information furnished by Micrel in this datasheet is believed to be accurate and reliable. However, no responsibility is assumed by Micrel for its use. Micrel reserves the right to change circuitry and specifications at any time without notification to the customer.

Micrel Products are not designed or authorized for use as components in life support appliances, devices or systems where malfunction of a product can reasonably be expected to result in personal injury. Life support devices or systems are devices or systems that (a) are intended for surgical implant into the body or (b) support or sustain life, and whose failure to perform can be reasonably expected to result in a significant injury to the user. A Purchaser's use or sale of Micrel Products for use in life support appliances, devices or systems is at Purchaser's own risk and Purchaser agrees to fully indemnify Micrel for any damages resulting from such use or sale.

© 2005 Micrel, Incorporated.

## X-ON Electronics

Largest Supplier of Electrical and Electronic Components

*Click to view similar products for [Laser Drivers](#) category:*

*Click to view products by [Microchip](#) manufacturer:*

Other Similar products are found below :

[AXXSATADVDRWROM937575 937575](#) [ADN2872ACPZ](#) [AD9665ACPZ-REEL7](#) [ADN2841ACPZ-48](#) [ADN2847ACPZ-32](#) [ADN2871ACPZ](#)  
[ADN2841ACPZ-32](#) [HMC7144LC4](#) [HMC7144LC4TR](#) [HMC7150LP3DE](#) [HMC7810ALC3](#) [SY88922VKG](#) [DS1873T+](#) [DS1874T+](#)  
[MAX3740AETG+T](#) [MAX3643ETG+T](#) [MAX3646ETG+T](#) [MAX3949ETE+T](#) [MAX3869ETJ](#) [DS1863E](#) [SY88422LMG](#) [MAX3669EHJ](#)  
[SY88992LMG-TR](#) [SY88982LMG](#) [SY84782UMG](#) [SY88022ALMG](#) [SY88992LMG](#) [SY88236LMG](#) [SY88432LMG-TR](#) [SY88432LMG](#)  
[ONET1151LRGET](#) [ONET1151PRGTT](#) [ONET4201LDRGER](#) [ONET4201LDRGET](#) [ONET4211LDRGET](#) [ONET1101LRGER](#)  
[ONET1151LRGER](#) [ONET8501VRGPT](#) [MAX3948ETE](#) [MAX24002TL+](#) [DS1864T+](#) [DS1862B](#) [LTC5100EUF#PBF](#) [DS1862AB+](#)  
[MAX3656ETG+T](#) [LMH6525SP/NOPB](#) [LMH6526SPNOPB](#) [ONET1141LRGET](#)