

# SY89854U



## Precision Low Power 1:4 LVPECL Fanout Buffer/Translator with Internal Termination

### General Description

The SY89854U is a 2.5V/3.3V precision, high-speed, fully differential 1:4 LVPECL fanout buffer. Optimized to provide four identical output copies with less than 20ps of skew and less than 10ps<sub>(pp)</sub> total jitter, the SY89854U can process clock signals as fast as 2GHz.

The differential input includes Micrel's unique, patent pending 3-pin input termination architecture that interfaces to any differential signal (AC or DC-coupled) as small as 100mV (200mV<sub>pp</sub>) without any level shifting or termination resistor networks in the signal path. For AC-coupled input interface applications, an on-board output reference voltage (VREF-AC) is provided to bias the center-tap (VT) pin. The outputs are 800mV LVPECL, with fast rise/fall times guaranteed to be less than 180ps.

The SY89854U operates from a 2.5V  $\pm$ 5% supply or a 3.3V  $\pm$ 10% supply and is guaranteed over the full industrial temperature range of  $-40^{\circ}\text{C}$  to  $+85^{\circ}\text{C}$ . The SY89854U is part of Micrel's high-speed, Precision Edge<sup>®</sup> product line.

All support documentation can be found on Micrel's web site at: [www.micrel.com](http://www.micrel.com).



Precision Edge<sup>®</sup>

### Features

- Precision 1:4, LVPECL fanout buffer
- Low power: 137mW (2.5V typ)
- Guaranteed AC performance over temperature and supply voltage:
  - DC- to > 2GHz Clock  $f_{\text{MAX}}$
  - <340ps  $t_{\text{pd}}$
  - <180ps  $t_r/t_f$  time
  - <20ps max. skew
- Ultra-low jitter design:
  - <1ps<sub>(rms)</sub> random jitter
  - <10ps<sub>(pp)</sub> deterministic jitter
  - <10ps<sub>(pp)</sub> total jitter (clock)
- Unique patent pending input termination and VT pin accepts DC-coupled and AC-coupled inputs (CML, PECL, LVDS)
- Typical 800mV (100k) LVPECL output swing
- Power supply 2.5V  $\pm$ 5% or 3.3V  $\pm$ 10%
- Industrial temperature range  $-40^{\circ}\text{C}$  to  $+85^{\circ}\text{C}$
- Available in ultra-small (3mm x 3mm) 16-pin QFN package

### Typical Applications

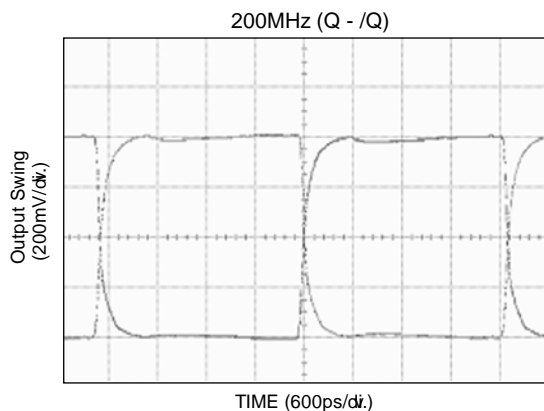

United States Patent No. RE44,134

Precision Edge is a registered trademark of Micrel, Inc.

### Applications

- SONET and All GigE clock distribution
- Fibre Channel clock and data distribution
- Backplane distribution

### Ordering Information<sup>(1)</sup>

Part Number	Package Type	Operating Range	Package Marking	Lead Finish
SY89854UMG	QFN-16	Industrial	854U with Pb-free bar-line indicator	Pb-Free NiPdAu
SY89854UMGTR <sup>(2)</sup>	QFN-16	Industrial	854U with Pb-free bar-line indicator	Pb-Free NiPdAu

**Notes:**

1. Contact factory for die availability. Dice are guaranteed at T<sub>A</sub> = 25°C, DC Electricals Only.
2. Tape and Reel.

### Pin Configuration

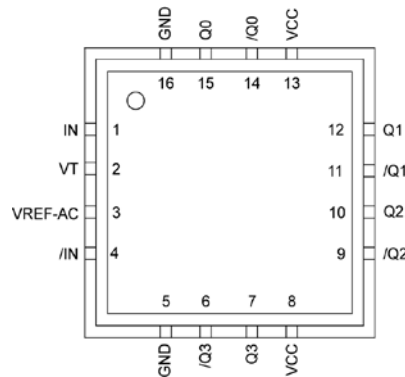

16-Pin QFN

### Pin Description

Pin Number	Pin Name	Pin Function
1, 4	IN, /IN	Differential Input: This input pair is the signal to be buffered. These inputs accept AC- or DC-coupled differential signals as small as 100mV (200mV <sub>PP</sub> ). Each pin of this pair internally terminates to a VT pin through 50Ω. Note that this input will default to an indeterminate state if left open. Please refer to the “Input Interface Applications” section for more details.
2	VT	Input Termination Center-Tap: Each side of the differential input pair terminates to this pin. The VT pin provides a center-tap to a termination network for maximum interface flexibility. See “Input Interface Applications” section for more details.
8,13	VCC	Positive Power Supply. Bypass with 0.1μF  0.01μF low ESR capacitors as close to the VCC pin as possible.
15, 14 12, 11 10, 9 7, 6	Q0, /Q0 Q1, /Q1 Q2, /Q2 Q3, /Q3	Differential 100K LVPECL Output: These LVPECL outputs are the precision, low skew copies of the input signal. Terminate with 50Ω to V <sub>CC</sub> -2V. Unused output pairs may be left floating with no impact on jitter. See “Output Interface Applications” section.
5, 16	GND, Exposed Pad	Ground. Ground pin and exposed pad must be connected to the same ground plane.
3	VREF-AC	Reference Voltage: This output biases to V <sub>CC</sub> -1.2V. It is used when AC coupling the inputs (IN, /IN). Connect V <sub>REF-AC</sub> to the VT pin. Bypass VREF-AC pin with a 0.01μF low ESR capacitor to V <sub>CC</sub> . Maximum sink/source capability is 1.5mA. See “Input Interface Applications” section for more details.

### Functional Block Diagram

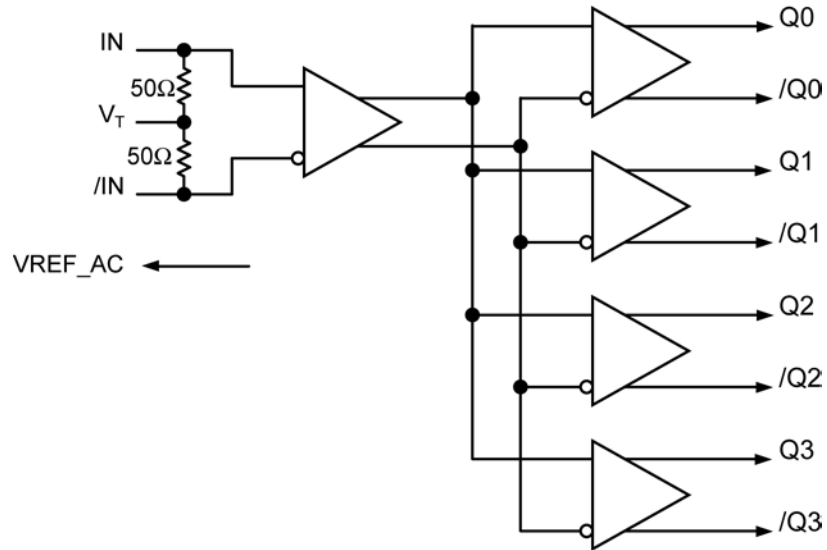

### Absolute Maximum Ratings<sup>(1)</sup>

Supply Voltage ( $V_{CC}$ )	.....	-0.5V to +4.0V
Input Voltage ( $V_{IN}$ )	.....	-0.5V to $V_{CC}$
LVPECL Output Current ( $I_{OUT}$ )		
Continuous	.....	50mA
Surge	.....	100mA
Termination Current <sup>(3)</sup>		
Source or sink current on $V_T$	.....	$\pm 50$ mA
Input Current		
Source or sink current on IN, /IN	.....	$\pm 50$ mA
VREF-AC Current <sup>(3)</sup>		
Source or sink current	.....	$\pm 2$ mA
Lead Temperature (soldering, 20sec.)	.....	+260°C
Storage Temperature ( $T_s$ )	.....	-65°C to 150°C

### Operating Ratings<sup>(2)</sup>

Supply Voltage ( $V_{CC}$ )	.....	+2.375V to +2.625V
	.....	+3.0V to +3.6V
Ambient Temperature ( $T_A$ )	.....	-40°C to +85°C
Package Thermal Resistance <sup>(4)</sup>		
QFN ( $\theta_{JA}$ )		
Still-Air	.....	60°C/W
QFN ( $\psi_{JB}$ )		
Junction-to-Board	.....	38°C/W

### DC Electrical Characteristics <sup>(5)</sup>

$T_A = -40^\circ\text{C}$  to  $+85^\circ\text{C}$ , unless otherwise stated.

Symbol	Parameter	Condition	Min	Typ	Max	Units
$V_{CC}$	Power Supply		2.375	2.5	2.625	V
			3.0	3.3	3.6	V
$I_{CC}$	Power Supply Current	No load, max. $V_{CC}$		55	78	mA
$R_{DIFF\_IN}$	Differential Input Resistance (IN, /IN)		90	100	110	$\Omega$
$R_{IN}$	Input Resistance (IN-to- $V_T$ )		45	50	55	$\Omega$
$V_{IH}$	Input High Voltage (IN, /IN)	Note 6	$V_{CC} - 1.6$		$V_{CC}$	V
$V_{IL}$	Input Low Voltage (IN, /IN)		0		$V_{IH} - 0.1$	V
$V_{IN}$	Input Voltage Swing (IN, /IN)	See Figure 1a.	0.1		1.7	V
$V_{DIFF\_IN}$	Differential Input Voltage Swing (IN, /IN)	See Figure 1b.	0.2			V
$V_{T\_IN}$	IN-to- $V_T$				1.28	V

**Notes:**

1. Permanent device damage may occur if the Absolute Maximum Ratings are exceeded. This is a stress rating only and functional operation is not implied at conditions other than those detailed in the operational sections of this data sheet. Exposure to Absolute Maximum Ratings conditions for extended periods may affect device reliability.
2. The data sheet limits are not guaranteed if the device is operated beyond the operating ratings.
3. Due to the limited drive capability use for input of the same package only.
4. Package thermal resistance assumes exposed pad is soldered (or equivalent) to the devices most negative potential on the PCB.  $\theta_{JA}$  and  $\psi_{JB}$  are calculated based on a 4-layer board in still air, unless otherwise stated.
5. The circuit is designed to meet the DC specifications shown in the above table after thermal equilibrium has been established.
6.  $V_{IH}$  (min) not lower than 1.2V.

## LVPECL Outputs DC Electrical Characteristics<sup>(7)</sup>

$V_{CC} = +2.5V \pm 5\%$  or  $+3.3V \pm 10\%$ ;  $T_A = -40^\circ C$  to  $+85^\circ C$ ;  $R_L = 50\Omega$  to  $V_{CC} - 2V$ , unless otherwise stated.

Symbol	Parameter	Condition	Min	Typ	Max	Units
$V_{OH}$	Output HIGH Voltage Q, /Q		$V_{CC} - 1.145$		$V_{CC} - 0.895$	V
$V_{OL}$	Output LOW Voltage Q, /Q		$V_{CC} - 1.945$		$V_{CC} - 1.695$	V
$V_{OUT}$	Output Voltage Swing Q, /Q	See Figure 1a.	550	800		mV
$V_{DIFF-OUT}$	Differential Output Voltage Swing Q,/Q	See Figure 1b.	1100	1600		mV

**Note:**

7. The circuit is designed to meet the DC specifications shown in the above table after thermal equilibrium has been established.

## AC Electrical Characteristics<sup>(8)</sup>

$V_{CC} = +2.5V \pm 5\%$  or  $+3.3V \pm 10\%$ ;  $T_A = -40^\circ C$  to  $+85^\circ C$ ,  $R_L = 50\Omega$  to  $V_{CC} - 2V$ , unless otherwise stated.

Symbol	Parameter	Condition	Min	Typ	Max	Units
$f_{MAX}$	Maximum Operating Frequency	Clock, $V_{OUT} \geq 400mV$	2.0	3.5		GHz
		NRZ Data		2.5		Gbps
$t_{pd}$	Propagation Delay (IN-to-Q)	$V_{IN} \geq 100mV_{pk}$	140	220	340	ps
$t_{pd}$ Tempco	Differential Propagation Delay Temperature Coefficient			100		fs/ $^\circ C$
$t_{SKEW}$	Output-to-Output Skew	Note 9		4	20	ps
	Part-to-Part Skew	Note 10			150	ps
$t_{Jitter}$	Random Jitter (RJ)	Note 11			1	ps <sub>RMS</sub>
	Deterministic Jitter (DJ)	Note 12			10	ps <sub>PP</sub>
	Cycle-to-Cycle Jitter	Note 13			1	ps <sub>RMS</sub>
	Total Jitter	Note 14			10	ps <sub>PP</sub>
$t_r, t_f$	Output Rise/Fall Time (20% to 80%)	At full output swing.	50	100	180	ps

### Notes:

8. High-frequency AC-parameters are guaranteed by design and characterization.
9. Output-to-output skew is measured between outputs under identical conditions.
10. Part-to-part skew is defined for two parts with identical power supply voltages at the same temperature and with no skew of the edges at the respective inputs. Part-to-part skew includes variation in  $t_{pd}$ .
11. Random jitter is measured with a K28.7 character pattern, measured at 2.5Gbps.
12. DJ is measured at 2.5Gbps, with both K28.5 and  $2^{23} - 1$  PRBS pattern.
13. Cycle-to-cycle jitter definition: The variation of periods between adjacent cycles,  $T_n - T_{n-1}$  where T is the time between rising edges of the output signal.
14. Total jitter definition: with an ideal clock input of frequency  $< f_{MAX}$ , no more than one output edge in  $10^{12}$  output edges will deviate by more than the specified peak-to-peak jitter value.

## Typical Operating Characteristics

$V_{CC} = 2.5V$ ,  $V_{IN} = 100mV_{pk}$ ,  $T_A = 25^{\circ}C$ , unless otherwise stated.

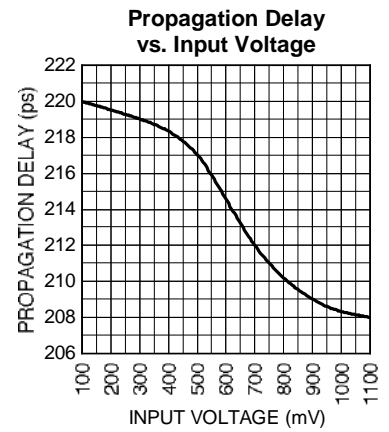
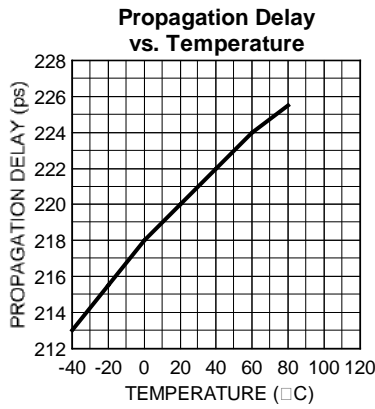
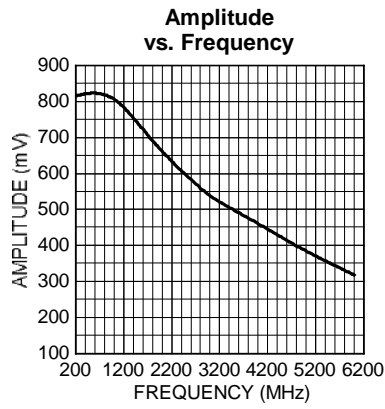

### Functional Characteristics

$V_{CC} = 2.5V$ ,  $V_{IN} = 100mV$ ,  $T_A = 25^\circ C$ , unless otherwise stated.

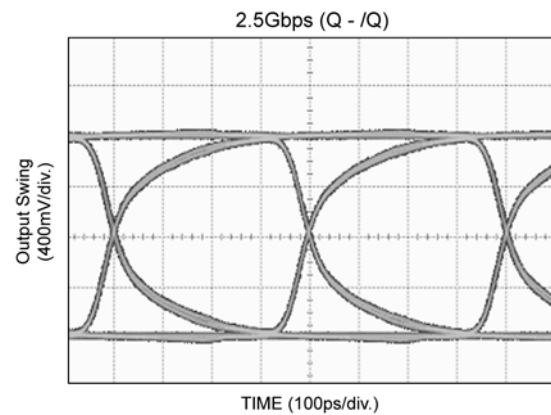
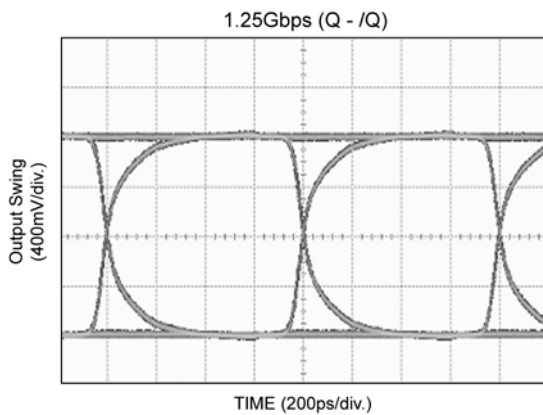
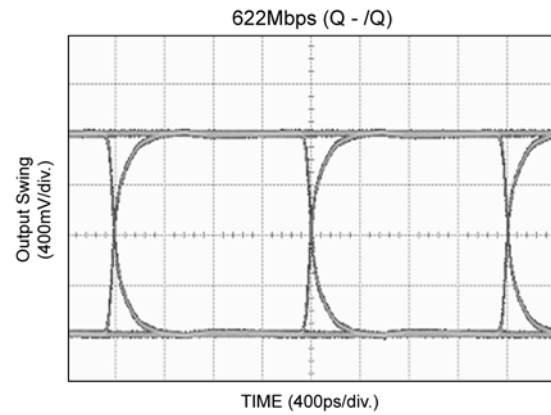
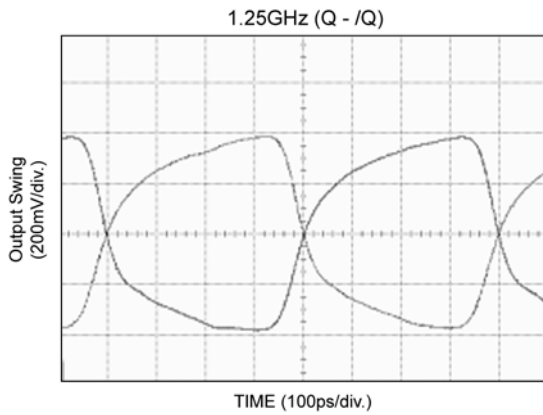
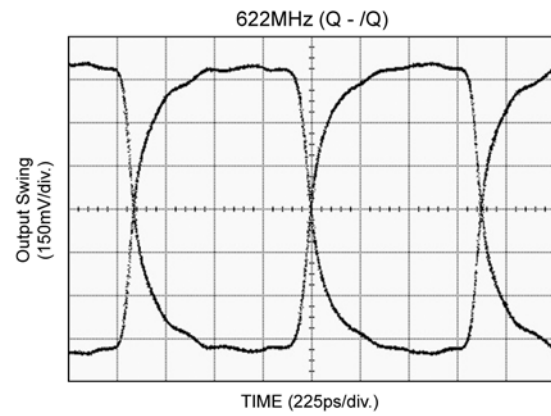
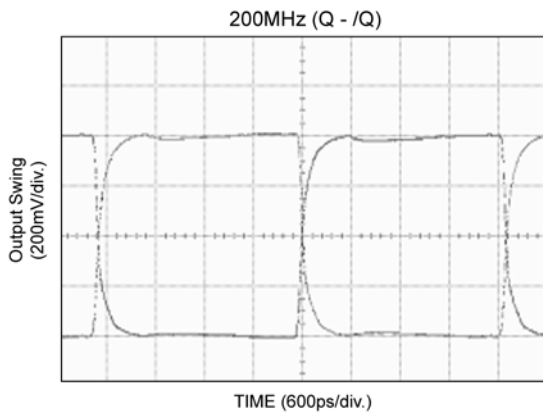



### Single-Ended and Differential Swings

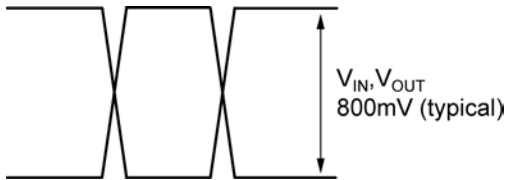

Figure 1a. Single-Ended Voltage Swing

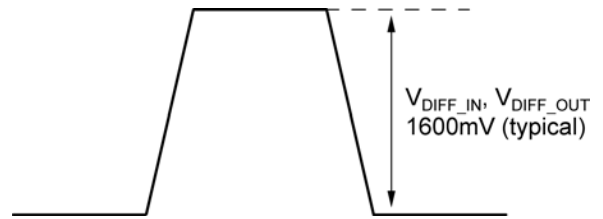
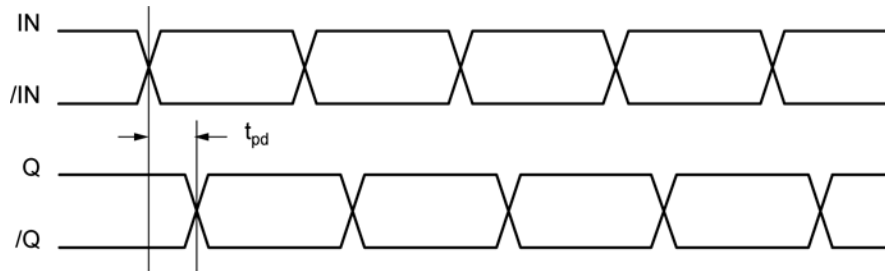

Figure 1b. Differential Voltage Swing

### Timing Diagrams



### Input and Output Stages

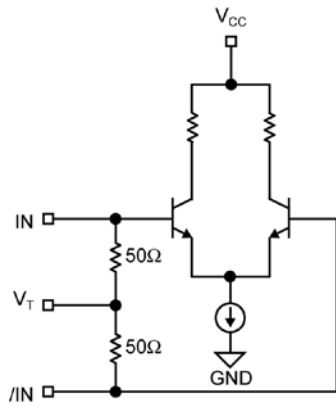

Figure 2a. Simplified Differential Input Stage

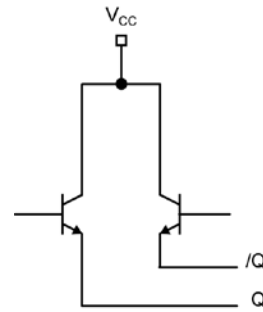
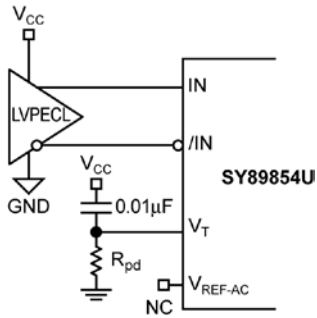

Figure 2b. Simplified LVPECL Output Stage

## Input Interface Applications



Note:  
 For 3.3V,  $R_{pd} = 50\Omega$ .  
 For 2.5V,  $R_{pd} = 19\Omega$ .

**3a. LVPECL Interface (DC-Coupled)**

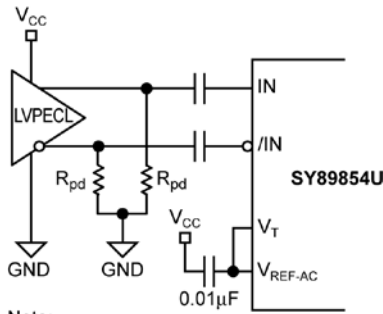

Note:  
 For 3.3V,  $R_{pd} = 100\Omega$ .  
 For 2.5V,  $R_{pd} = 50\Omega$ .

**3b. LVPECL Interface (AC-Coupled)**

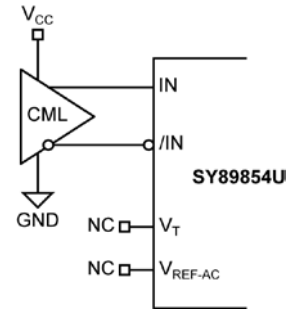

Option: may connect  $V_T$  to  $V_{CC}$

**3c. CML Interface (DC-Coupled)**

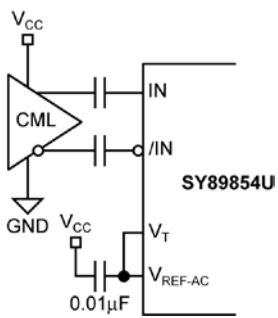

**3d. CML Interface (AC-Coupled)**

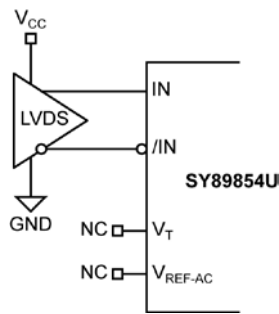

**3e. LVDS Interface**

### Output Interface Applications

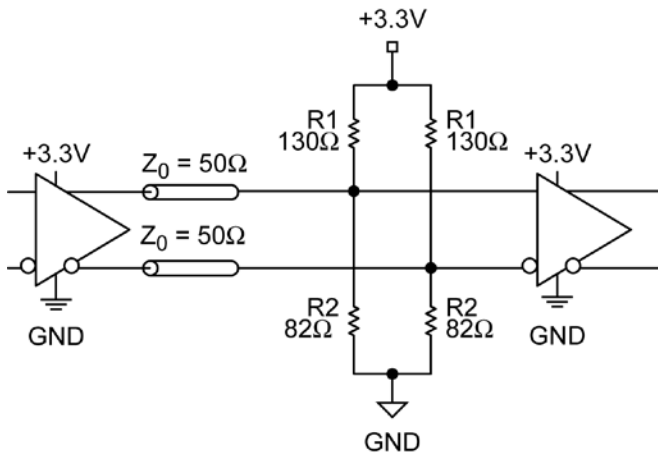

**Note:**  
For +2.5V systems, R1 = 250Ω, R2 = 82.5Ω

**Figure 4a. Parallel Thevenin-Equivalent Termination**

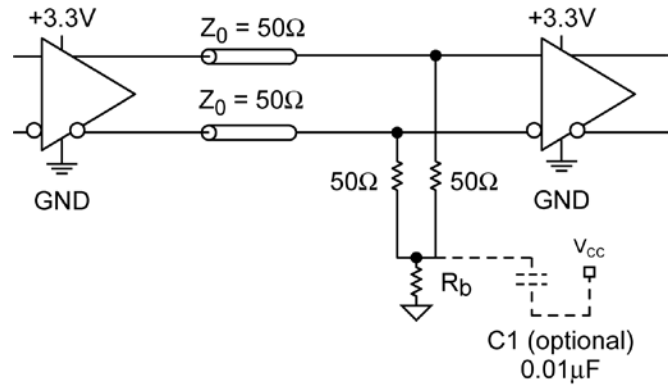

**Note:**  
For +2.5V systems, Rb = 19Ω  
For +3.3V systems, Rb = 50Ω

**Figure 4b. Parallel Termination (3-Resistor)**

### Related Product and Support Documentation

Part Number	Function	Data Sheet Link
SY58021U	4GHz, 1:4 LVPECL Fanout Buffer/Translator with Internal Termination	<a href="http://www.micrel.com/product-info/products/sy58021u.shtml">www.micrel.com/product-info/products/sy58021u.shtml</a>
HBW Solutions	New Products and Applications	<a href="http://www.micrel.com/product-info/products/solutions.shtml">www.micrel.com/product-info/products/solutions.shtml</a>

### 16-Pin QFN

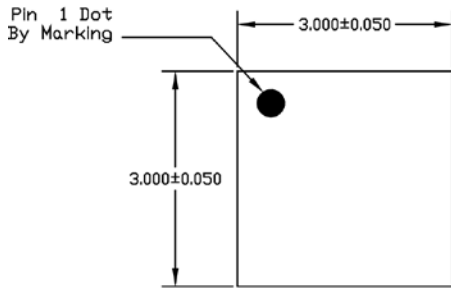

TOP VIEW

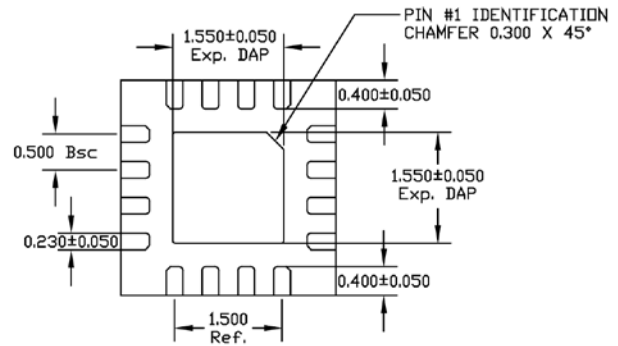

BOTTOM VIEW

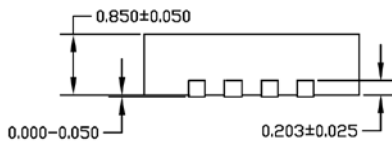

SIDE VIEW

- NOTE:
1. ALL DIMENSIONS ARE IN MILLIMETERS.
  2. MAX. PACKAGE WARPAGE IS 0.05 mm.
  3. MAXIMUM ALLOWABLE BURRS IS 0.076 mm IN ALL DIRECTIONS.
  4. PIN #1 ID ON TOP WILL BE LASER/INK MARKED.

**Package Notes:**

- (1) Package meets Level 2 Moisture Sensitivity Classification.
- (2) All parts are dry-packaged before shipment.
- (3) Exposed pad must be soldered to a ground for proper thermal management.

**MICREL, INC. 2180 FORTUNE DRIVE SAN JOSE, CA 95131 USA**  
 TEL +1 (408) 944-0800 FAX +1 (408) 474-1000 WEB <http://www.micrel.com>

The information furnished by Micrel in this data sheet is believed to be accurate and reliable. However, no responsibility is assumed by Micrel for its use. Micrel reserves the right to change circuitry and specifications at any time without notification to the customer.

Micrel Products are not designed or authorized for use as components in life support appliances, devices or systems where malfunction of a product can reasonably be expected to result in personal injury. Life support devices or systems are devices or systems that (a) are intended for surgical implant into the body or (b) support or sustain life, and whose failure to perform can be reasonably expected to result in a significant injury to the user. A Purchaser's use or sale of Micrel Products for use in life support appliances, devices or systems is a Purchaser's own risk and Purchaser agrees to fully indemnify Micrel for any damages resulting from such use or sale.

© 2005 Micrel, Incorporated.

## X-ON Electronics

Largest Supplier of Electrical and Electronic Components

*Click to view similar products for [Buffers & Line Drivers](#) category:*

*Click to view products by [Microchip](#) manufacturer:*

Other Similar products are found below :

[LXV200-024SW](#) [74AUP2G34FW3-7](#) [HEF4043BP](#) [PI74FCT3244L](#) [MC74HCT365ADTR2G](#) [Le87401NQC](#) [Le87402MQC](#) [028192B](#)  
[042140C](#) [051117G](#) [070519XB](#) [NL17SZ07P5T5G](#) [NLU1GT126AMUTCG](#) [74AUP1G17FW5-7](#) [74LVC2G17FW4-7](#) [CD4502BE](#) [5962-](#)  
[8982101PA](#) [5962-9052201PA](#) [74LVC1G125FW4-7](#) [NL17SH17P5T5G](#) [NL17SH125P5T5G](#) [NLV37WZ07USG](#) [74VHC541FT\(BE\)](#)  
[RHRXH162244K1](#) [74AUP1G34FW5-7](#) [74AUP1G07FW5-7](#) [74LVC1G126FW4-7](#) [74LVC2G126RA3-7](#) [NLX2G17CMUTCG](#)  
[74LVCE1G125FZ4-7](#) [Le87501NQC](#) [74AUP1G126FW5-7](#) [TC74HC4050AP\(F\)](#) [74LVCE1G07FZ4-7](#) [NLX3G16DMUTCG](#)  
[NLX2G06AMUTCG](#) [NLVVHC1G50DFT2G](#) [LE87100NQC](#) [LE87290YQC](#) [LE87290YQCT](#) [LE87511NQC](#) [LE87511NQCT](#) [LE87557NQC](#)  
[LE87557NQCT](#) [LE87614MQC](#) [LE87614MQCT](#) [74AUP1G125FW5-7](#) [NLU2G16CMUTCG](#) [MC74LCX244MN2TWG](#) [NL17SG126DFT2G](#)