



UM4000 / UM4900

HIGH POWER PIN DIODES

RoHS Compliant Versions Available

DESCRIPTION

The UM4000 and UM4900 series features high power PIN diodes with long carrier lifetimes and thick I-regions. They are especially suitable for use in low distortion switches and attenuators, in HF through S band frequencies. While both series are electrically equivalent, the UM4900 series have higher power ratings due to a shorter thermal path between the chip and package. High charge storage and long carrier lifetime enable high RF levels to be controlled with relatively low bias current. Similarly, peak RF voltages can be handled well in excess of applied reverse bias voltage.

Both series have been fully qualified in high power UHF phase shifters and megawatt peak-power duplexers, accumulating thousands of hours of proven performance. Both types have been used in the design of antenna selectors and couplers, where inductance and capacitance elements are switched in and out of filter or cavity networks.

The standard finish for the UM4000 series is Sn/Pb. For RoHS compliant devices, use the UMX prefix. (IE: UMX4000SM) The UMX series meets RoHS requirements per EU Directive 2002/95/EC.

IMPORTANT:

For the most current data, consult our website: www.MICROSEMI.com

ABSOLUTE MAXIMUM RATINGS AT 25° C (UNLESS OTHERWISE SPECIFIED)

Package	Condition	UM4000		UM4900	
		PD (W)	θ (°C/W)	PD (W)	θ (°C/W)
A	25 °C Pin Temperature	25	6	37.5	4
B & E	½ in. total length to 25 °C Contact	12	1.25	12	12.5
	Free Air	2.5		2.5	
C	25 °C Stud Temperature	25	6	37.5	4
D	25 °C Stud Temperature	18.75	8	25	6
SM	25 °C End Cap Temperature	20	7	N/A	
All	1 us pulse (Single)	100 kW		100 kW	

VOLTAGE RATINGS

Reverse Voltage @ 10 uA	UM4000	UM4900
100	UM4001	UM4901
200	UM4002	UM4902
400	-	-
600	UM4006	UM4906
1000	UM4010	-

KEY FEATURES

- Voltage ratings to 1000 V
- Power dissipation to 37.5 W
- Series resistance rated at 0.5 Ω
- Carrier lifetime greater than 5 μ s
- Non cavity design
- RoHS compliant version available ¹
- Thermally matched configuration
- Low capacitance at 0 V bias
- Low conductance at 0 V bias
- Compatible with automatic insertion equipment

1- RoHS compliant version is supplied with a matte tin finish. (Order UMX4000, UMX4900)



APPLICATIONS/BENEFITS

- Isolated stud package available
- Surface mount package available



UM4000 / UM4900

HIGH POWER PIN DIODES

RoHS Compliant Versions Available

ELECTRICAL PARAMETERS @ 25°C (unless otherwise specified)

Parameter	Symbol	Conditions	Min	Typ.	Max	Units
Forward Voltage	V_F	$I_F = 100 \text{ mA}$			1.0	V
Reverse Current	I_R	At rated voltage			10	μA
Series Resistance	R_S	$I_F = 100 \text{ mA}$, $F = 100 \text{ MHz}$		0.3	0.5	Ohm
Capacitance	C_T	$V_R = 100 \text{ V}$, $F = 1 \text{ MHz}$		2.4	3	pF
Parallel Resistance	R_P	$V_R = 100 \text{ V}$, $F = 100 \text{ MHz}$	10k	15k		Ohms
Carrier Lifetime	τ	$I_F = 10 \text{ mA}$	5	10		μs

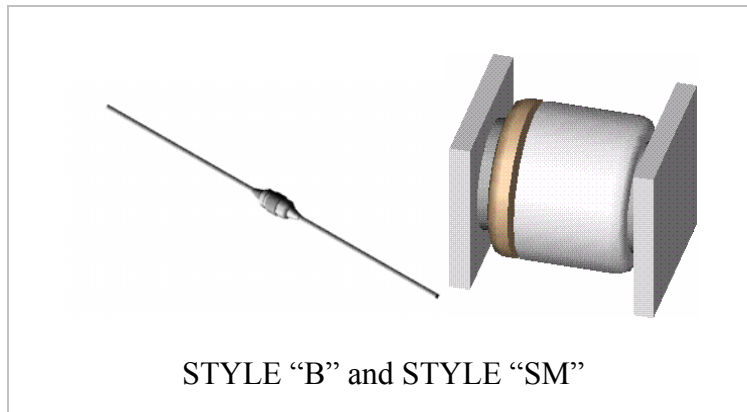



UM4000 / UM4900

HIGH POWER PIN DIODES

RoHS Compliant Versions Available

www.MICROSEMI.com

RP VS REVERSE BIAS

UM4000/UM4900
TYPICAL

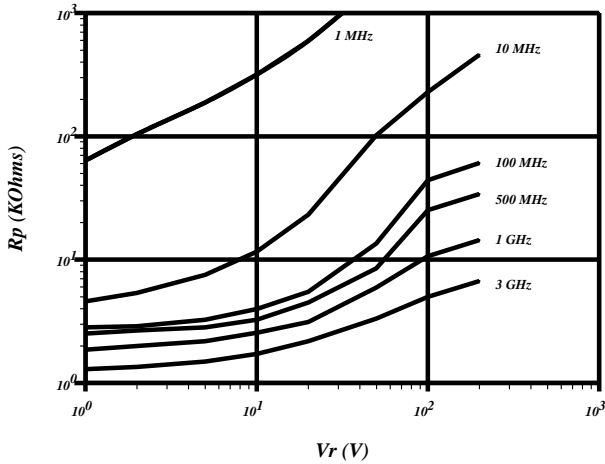

RS VS IF @ 100MHZ

UM4000/UM4900
TYPICAL

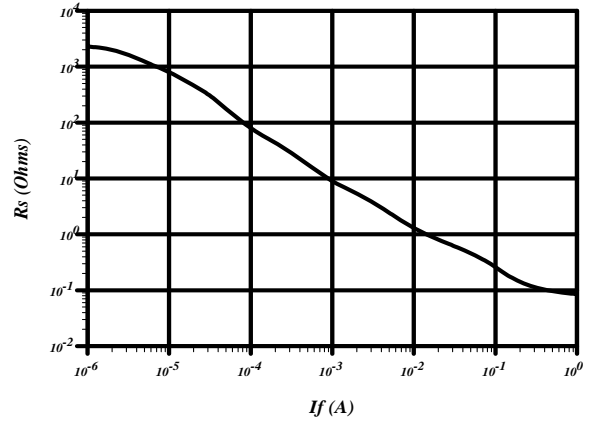

CT VS REVERSE VOLTAGE

UM4000/UM4900
TYPICAL

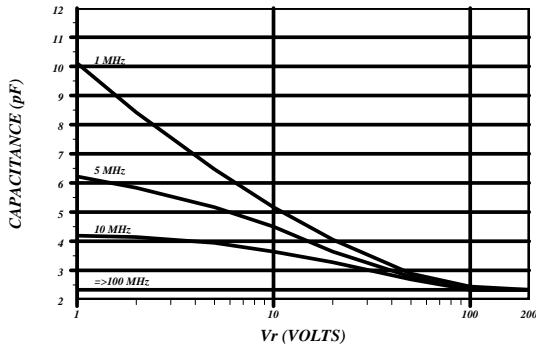

VF VS IF

UM4000/UM4900
TYPICAL

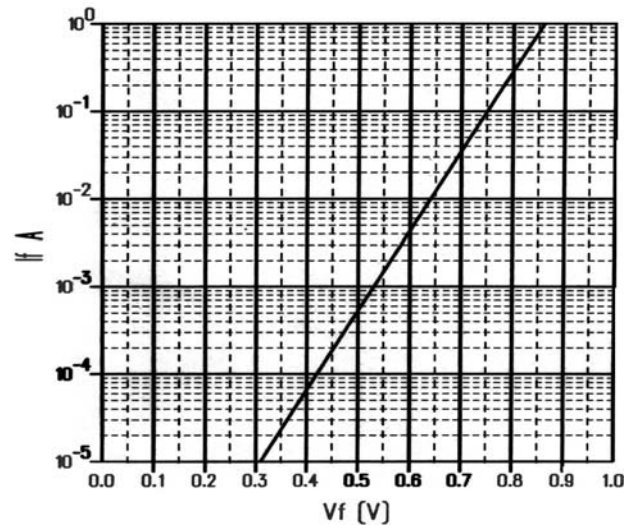

GRAPHS



UM4000 / UM4900

HIGH POWER PIN DIODES

RoHS Compliant Versions Available

TYPICAL POWER RATINGS

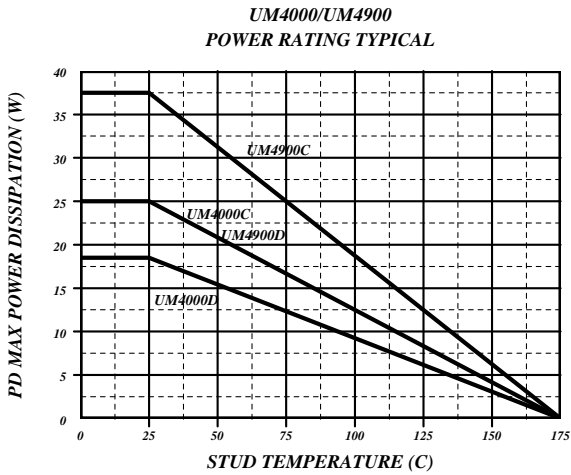

TYPICAL POWER RATINGS

UM4000/UM4900
POWER RATING TYPICAL

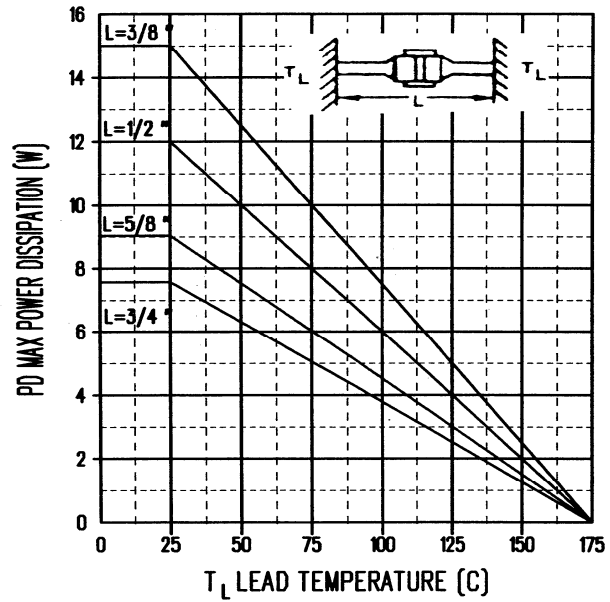

PULSED THERMAL IMPEDANCE

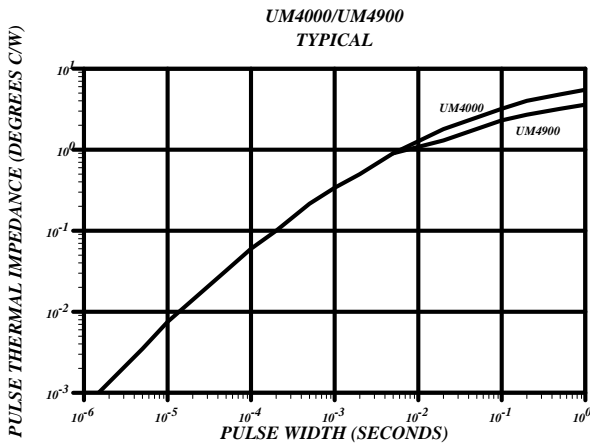

www.MICROSEMI.com

GRAPHS



UM4000 / UM4900

HIGH POWER PIN DIODES

RoHS Compliant Versions Available

STYLE "A"

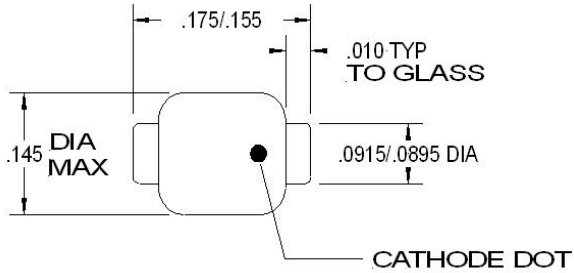

STYLE "B"

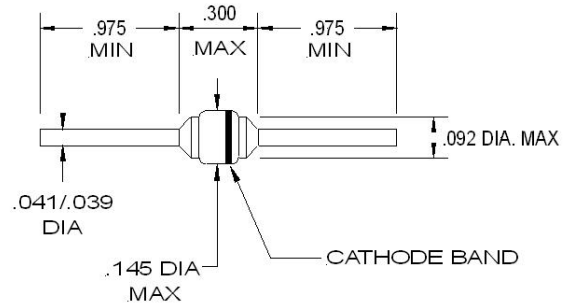

STYLE "C"

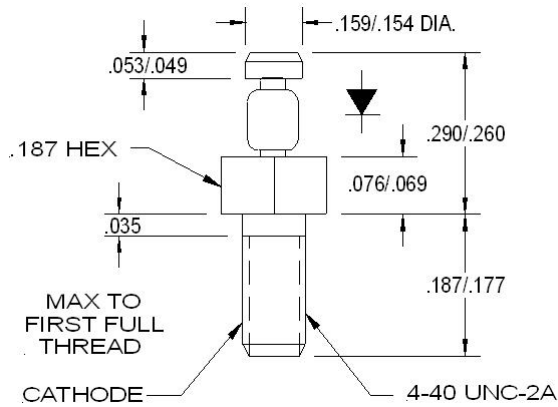

STYLE "CR"

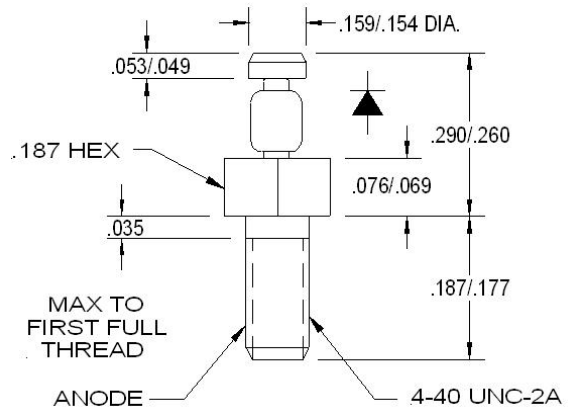

www.MICROSEMI.com

MECHANICAL



UM4000 / UM4900

HIGH POWER PIN DIODES

RoHS Compliant Versions Available

www.MICROSEMI.com

STYLE "D"

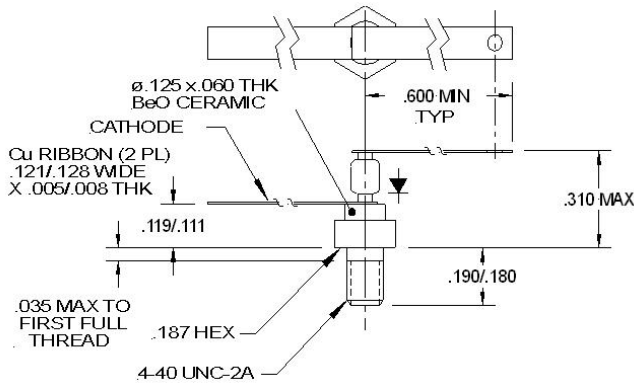

STYLE "DR"

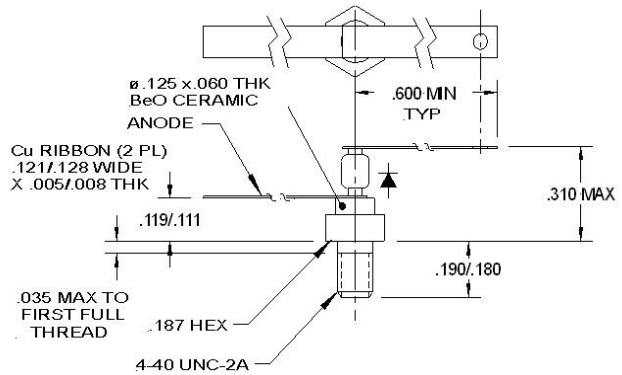

STYLE "E"

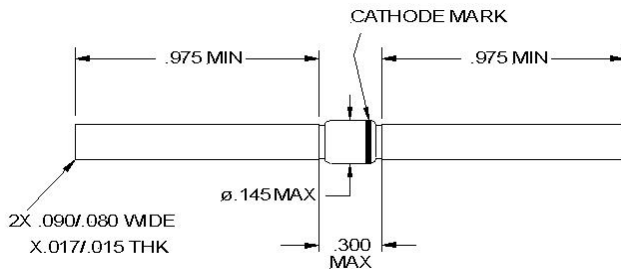

STYLE "SM"

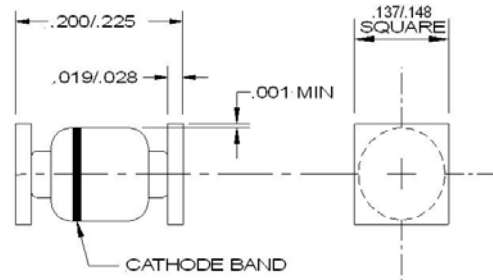

STYLE "SM" FOOTPRINT

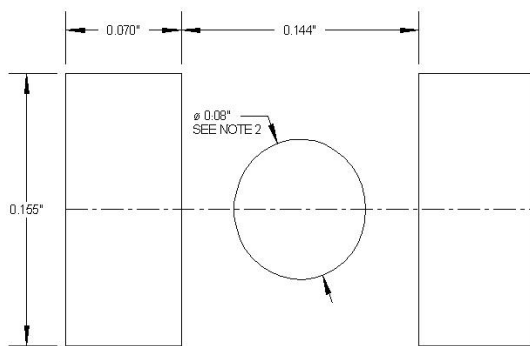

B SIZE
(STANDARD LARGE SQUARE END CAP OUTLINE)

STYLE "SM" FOOTPRINT NOTES

Notes:

- Footprint dimensions the terminals and allow for a solder fillet on each end provided placement accuracy is within 0.005"
- If the mounting method chosen requires the use of an adhesive in addition to the solder, then a round or square spot of adhesive should be centrally located as shown.

MECHANICAL

X-ON Electronics

Largest Supplier of Electrical and Electronic Components

Click to view similar products for [PIN Diodes](#) category:

Click to view products by [Microchip](#) manufacturer:

Other Similar products are found below :

[MA45471](#) [MA4SPS502](#) [APD2220-000](#) [APD0810-000](#) [MA4GP907](#) [MA4L032-186](#) [MA4L401-30](#) [MA4P606-258](#) [MA4P7435NM-1091T](#)
[MA4PK2000](#) [MA4PK2001](#) [MA4PK2004](#) [MADP-007167-12250T](#) [MADP-030025-13140P](#) [MA4SPS421](#) [MA4PBL027](#) [MA4P404-30](#)
[MA4AGFCP910](#) [MA4P7101F-1072T](#) [MA4L022-30](#) [MA47047-54](#) [BAR 89-02LRH E6327](#) [UM7108B](#) [UM9701](#) [1SV308,L3F](#) [UM9301SM](#)
[5082-3077](#) [GC4723-42](#) [MA4L011-1088](#) [MSW2001-200](#) [SMP1321-000](#) [M17X1008](#) [UM4010SM](#) [UM6002B](#) [UM7006A](#) [UM7006B](#)
[UM7108C](#) [GC4742-42](#) [MADP-000015-000030](#) [MGPN1503-C01A](#) [UMX512](#) [LXP1000-23-2](#) [LXP1004-23-2](#) [MPP4205A-206](#) [MPP4201-206](#)
[LXP1002-23-0](#) [LXP1004-23-0](#) [MPP4202-206](#) [MPP4205-206](#) [MPC8050-206](#)