Hi-Speed USB Transceiver with 1.8 V-3.3 V ULPI Interface - 24 MHz Reference Clock

Highlights

- USB-IF “Hi-Speed” compliant to the Universal Serial Bus Specification Rev 2.0
- Interface compliant with the ULPI Specification revision 1.1 as a Single Data Rate (SDR) PHY
- 1.8 V to 3.3 V IO Voltage ($\pm 10\%$)
- flexPWR[®] Technology
 - Low current design ideal for battery powered applications
 - “Sleep” mode tri-states all ULPI pins and places the part in a low current state
- Supports FS pre-amble for FS hubs with a LS device attached (UTMI+ Level 3)
- Supports HS SOF and LS keep-alive pulse
- Includes full support for the optional On-The-Go (OTG) protocol detailed in the On-The-Go Supplement Revision 2.0 specification
- Supports the OTG Host Negotiation Protocol (HNP) and Session Request Protocol (SRP)
- Allows host to turn VBUS off to conserve battery power in OTG applications
- Support OTG monitoring of VBUS levels with internal comparators
- “Wrapper-less” design for optimal timing performance and design ease
 - Low Latency Hi-Speed Receiver (43 Hi-Speed clocks Max) allows use of legacy UTMI Links with a ULPI bridge
- Internal 5 V cable short-circuit protection of ID, DP and DM lines to VBUS or ground
- 24 MHz Reference Clock Operation
 - 0 to 3.6 V input drive tolerant
 - Able to accept “noisy” clock sources
- Internal low jitter PLL for 480 MHz Hi-Speed USB operation
- Internal detection of the value of resistance to ground on the ID pin
- Integrated battery to 3.3 V LDO regulator
 - 2.2 μ F bypass capacitor
 - 100 mV dropout voltage
- Integrated ESD protection circuits
 - Up to ± 15 kV without any external devices
- CarKit UART mode for non-USB serial data transfers
- Industrial Operating Temperature
 - 40 °C to +85 °C

• Packaging Options

- 24 pin QFN lead-free RoHS compliant package;
(4 x 4 x 0.90 mm height)

Applications

The USB3315 is targeted for any application where a Hi-Speed USB connection is desired and when board space, power, and interface pins must be minimized.

The USB3315 is well suited for:

- Cell Phones
- PDAs
- MP3 Players
- GPS Personal Navigation
- Scanners
- External Hard Drives
- Digital Still and Video Cameras
- Portable Media Players
- Entertainment Devices
- Printers
- Set Top Boxes
- Video Record/Playback Systems
- IP and Video Phones
- Gaming Consoles
- POS Terminals

TO OUR VALUED CUSTOMERS

It is our intention to provide our valued customers with the best documentation possible to ensure successful use of your Microchip products. To this end, we will continue to improve our publications to better suit your needs. Our publications will be refined and enhanced as new volumes and updates are introduced.

If you have any questions or comments regarding this publication, please contact the Marketing Communications Department via E-mail at docerrors@microchip.com. We welcome your feedback.

Most Current Data Sheet

To obtain the most up-to-date version of this data sheet, please register at our Worldwide Web site at:

<http://www.microchip.com>

You can determine the version of a data sheet by examining its literature number found on the bottom outside corner of any page. The last character of the literature number is the version number, (e.g., DS30000000A is version A of document DS30000000).

Errata

An errata sheet, describing minor operational differences from the data sheet and recommended workarounds, may exist for current devices. As device/documentation issues become known to us, we will publish an errata sheet. The errata will specify the revision of silicon and revision of document to which it applies.

To determine if an errata sheet exists for a particular device, please check with one of the following:

- Microchip's Worldwide Web site; <http://www.microchip.com>
- Your local Microchip sales office (see last page)

When contacting a sales office, please specify which device, revision of silicon and data sheet (include -literature number) you are using.

Customer Notification System

Register on our web site at www.microchip.com to receive the most current information on all of our products.

Table of Contents

1.0 General Description	4
2.0 USB3315 Pin Locations and Definitions	5
3.0 Limiting Values	8
4.0 Electrical Characteristics	10
5.0 Architecture Overview	18
6.0 ULPI Operation Overview	32
7.0 ULPI Register Map	48
8.0 Applications Notes	59
9.0 Package Outline	64
Appendix A: Data Sheet Revision History	69
Appendix B: References	71
The Microchip Web Site	72
Customer Change Notification Service	72
Customer Support	72
Product Identification System	73

USB3315

1.0 GENERAL DESCRIPTION

The USB3315 is a highly integrated Hi-Speed USB 2.0 Transceiver (PHY) that supports systems architectures based on a 24 MHz reference clock. It is designed to be used in both commercial and industrial temperature applications.

The USB3315 meets all of the electrical requirements to be used as a Hi-Speed USB Host, Device, or an On-the-Go (OTG) device. In addition to the supporting USB signaling the USB3315 also provides USB UART mode.

USB3315 uses the industry standard UTMI+ Low Pin Interface (ULPI) to connect the USB PHY to the Link. The industry standard ULPI interface uses a method of in-band signaling and status byte transfers between the Link and PHY, to facilitate a USB session. By using in-band signaling and status byte transfers the ULPI interface requires only 12 pins.

The USB3315 uses Microchip's "wrapper-less" technology to implement the ULPI interface. This "wrapper-less" technology allows the PHY to achieve a low latency transmit and receive time. Microchip's low latency transceiver allows an existing UTMI Link to be reused by adding a UTMI to ULPI bridge. By adding a bridge to the ASIC the existing and proven UTMI Link IP can be reused.

FIGURE 1-1: USB3315 BLOCK DIAGRAM

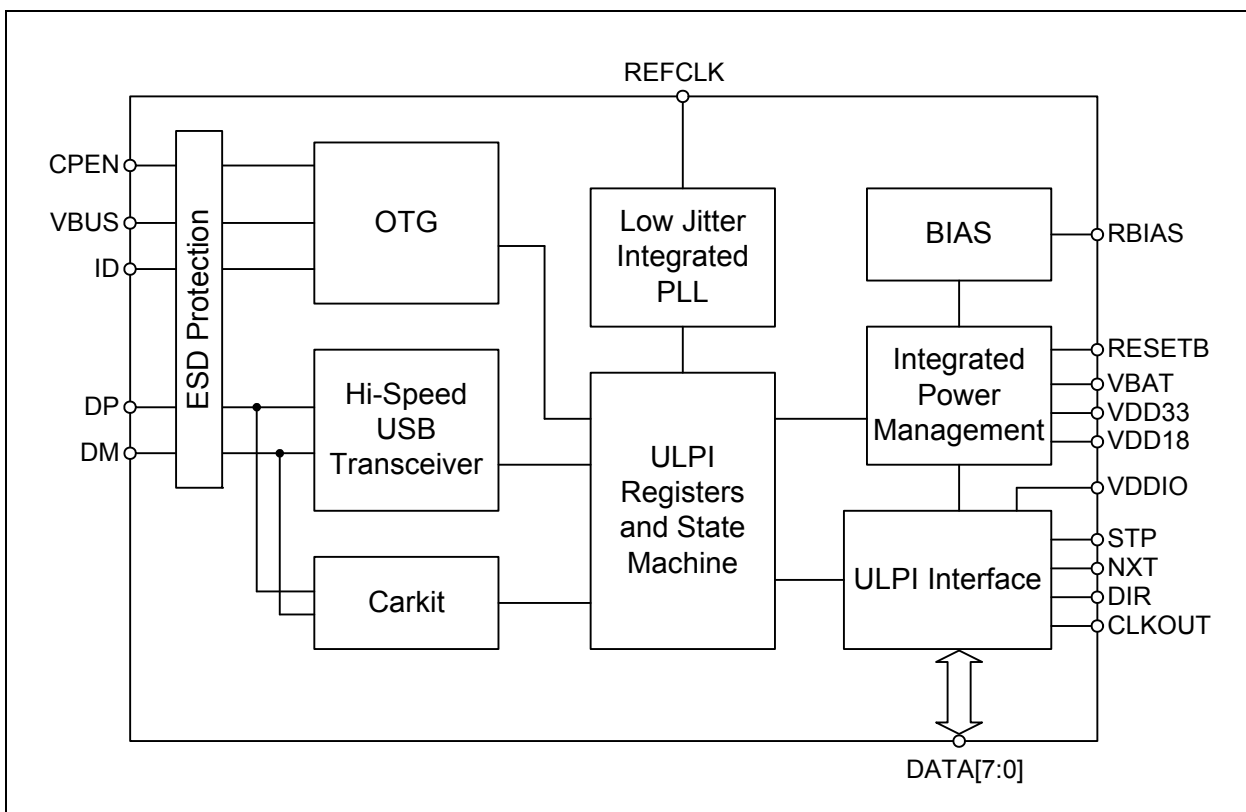

The USB3315 is designed to run with a 24 MHz reference clock. By using a reference clock from the Link the USB3315 is able to remove the cost of a crystal reference from the design.

The USB3315 includes an integrated 3.3 V LDO regulator to generate its own supply from power applied at the **VBAT** pin. The voltage on the **VBAT** pin can range from 3.1 to 5.5 V. The regulator dropout voltage is less than 100 mV which allows the PHY to continue USB signaling when the voltage on **VBAT** drops to 3.1 V. The USB transceiver will continue to operate at lower voltages, although some parameters may be outside the limits of the USB specifications. If the user would like to provide a 3.3 V supply to the USB3315, the **VBAT** and **VDD33** pins should be connected together as described in [Section 5.5.1](#).

The USB3315 also includes integrated pull-up resistors that can be used for detecting the attachment of a USB Charger. By sensing the attachment to a USB Charger, a product using the USB3315 can charge its battery at more than the 500 mA allowed when charging from a USB Host as described in [Section 8.2](#).

2.0 USB3315 PIN LOCATIONS AND DEFINITIONS

2.1 USB3315 Pin Locations and Descriptions

2.1.1 PACKAGE DIAGRAM WITH PIN LOCATIONS

The pinout below is viewed from the top of the package.

FIGURE 2-1: USB3315 QFN PINOUT - TOP VIEW

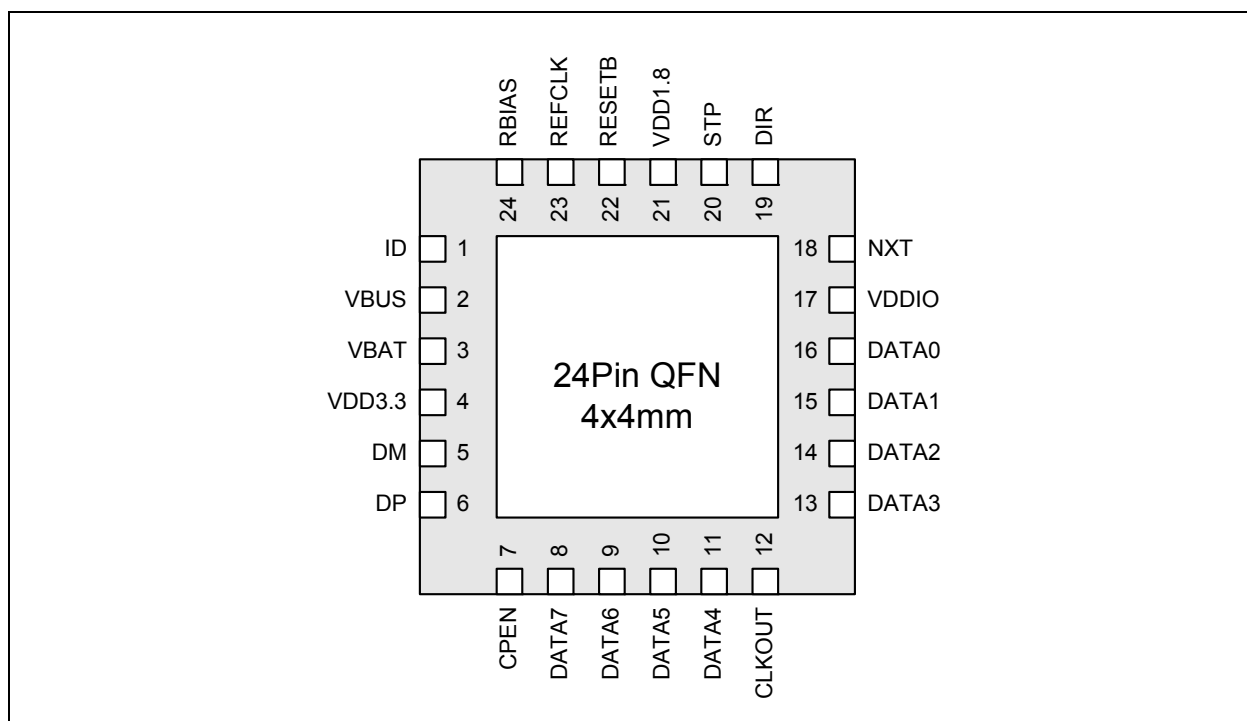

2.1.2 PIN DEFINITIONS

The following table details the pin definitions for the figure above.

TABLE 2-1: USB3315 PIN DESCRIPTION

Pin	Name	Direction/ Type	Active Level	Description
1	ID	Input, Analog	N/A	ID pin of the USB cable. For non-OTG applications this pin can be floated. For an A-Device ID is grounded. For a B-Device ID is floated.
2	VBUS	I/O, Analog	N/A	VBUS pin of the USB cable. This pin is used for the Vbus comparator inputs and for Vbus pulsing during session request protocol.
3	VBAT	Power	N/A	Regulator input. The regulator supply can be from 5.5 V to 3.1 V.

USB3315

TABLE 2-1: USB3315 PIN DESCRIPTION (CONTINUED)

Pin	Name	Direction/ Type	Active Level	Description
4	VDD3.3	Power	N/A	3.3 V Regulator Output. A 2.2 μ F (<1 Ω ESR) bypass capacitor to ground is required for regulator stability. The bypass capacitor should be placed as close as possible to the USB3315.
5	DM	I/O, Analog	N/A	D- pin of the USB cable.
6	DP	I/O, Analog	N/A	D+ pin of the USB cable.
7	CPEN	Output, CMOS	High	External 5 V supply enable. This pin is used to enable the external Vbus power supply. The CPEN pin is low on POR. This pad uses VDD3.3 logic level.
8	DATA[7]	I/O, CMOS	N/A	ULPI bi-directional data bus. DATA[7] is the MSB.
9	DATA[6]	I/O, CMOS	N/A	ULPI bi-directional data bus.
10	DATA[5]	I/O, CMOS	N/A	ULPI bi-directional data bus.
11	DATA[4]	I/O, CMOS	N/A	ULPI bi-directional data bus.
12	CLKOUT	Output, CMOS	N/A	60 MHz reference clock output. All ULPI signals are driven synchronous to the rising edge of this clock. Following POR or hardware reset, the voltage at CLKOUT must not exceed V_{IH_ED} as provided in Table 4-4 .
13	DATA[3]	I/O, CMOS	N/A	ULPI bi-directional data bus.
14	DATA[2]	I/O, CMOS	N/A	ULPI bi-directional data bus.
15	DATA[1]	I/O, CMOS	N/A	ULPI bi-directional data bus.
16	DATA[0]	I/O, CMOS	N/A	ULPI bi-directional data bus. DATA[0] is the LSB.
17	VDDIO	Power	N/A	1.8 V to 3.3 V ULPI interface supply voltage. This voltage sets the value of V_{OH} for the ULPI interface.

TABLE 2-1: USB3315 PIN DESCRIPTION (CONTINUED)

Pin	Name	Direction/ Type	Active Level	Description
18	NXT	Output, CMOS	High	The PHY asserts NXT to throttle the data. When the Link is sending data to the PHY, NXT indicates when the current byte has been accepted by the PHY. The Link places the next byte on the data bus in the following clock cycle.
19	DIR	Output, CMOS	N/A	Controls the direction of the data bus. When the PHY has data to transfer to the Link, it drives DIR high to take ownership of the bus. When the PHY has no data to transfer it drives DIR low and monitors the bus for commands from the Link.
20	STP	Input, CMOS	High	The Link asserts STP for one clock cycle to stop the data stream currently on the bus. If the Link is sending data to the PHY, STP indicates the last byte of data was on the bus in the previous cycle.
21	VDD1.8	Power	N/A	External 1.8 V Supply input pin. This pad needs to be bypassed with a 0.1 μ F capacitor to ground, placed as close as possible to the USB3315.
22	RESETB	Input, CMOS	Low	When low, the part is suspended with all of the I/O tri-stated. When high the USB3315 will operate as a normal ULPI device.
23	REFCLK	Input, CMOS	N/A	24 MHz Reference Clock input.
24	RBIAS	Analog, CMOS	N/A	Rbias pin. This pin requires an 8.06 k Ω (\pm 1%) resistor to ground, placed as close as possible to the USB3315.
FLAG	GND	Ground	N/A	Ground. <u>QFN only:</u> The flag should be connected to the ground plane with a via array under the exposed flag. This is the main ground for the IC.

USB3315

3.0 LIMITING VALUES

3.1 Absolute Maximum Ratings

TABLE 3-1: ABSOLUTE MAXIMUM RATINGS

PARAMETER	SYMBOL	CONDITIONS	MIN	TYP	MAX	UNITS
Maximum VBUS , VBAT , ID , DP , DM , and CPEN voltage to GND	V_{MAX_5V}		-0.5		+6.0	V
Maximum VDD18 voltage to Ground	$V_{MAX_1.8V}$		-0.5		2.5	V
Maximum VDDIO voltage to Ground	V_{MAX_IOV}	$VDD18 = V_{DD18}$	-0.5		4.0	V
Maximum VDDIO voltage to Ground	V_{MAX_IOV}	$VDD18 = 0\text{ V}$	-0.5		0.7	V
Maximum VDD33 voltage to Ground	$V_{MAX_3.3V}$		-0.5		4.0	V
Maximum I/O voltage to Ground	V_{MAX_IN}		-0.5		$V_{DDIO} + 0.7$	V
QFN Package Junction to Ambient (θ_{JA})		Thermal vias per Layout Guidelines.		58		°C/W
QFN Package Junction to Case (θ_{JC})				11		°C/W
Operating Temperature	T_{MAX_OP}		-40		85	°C
Storage Temperature	T_{MAX_STG}		-55		150	°C

Note: Stresses beyond those listed under “Absolute Maximum Ratings” may cause permanent damage to the device. Exposure to absolute maximum rating conditions for extended periods may affect device reliability.

3.2 Recommended Operating Conditions

TABLE 3-2: RECOMMENDED OPERATING CONDITIONS

PARAMETER	SYMBOL	CONDITIONS	MIN	TYP	MAX	UNITS
VBAT to GND	V_{VBAT}		3.1		5.5	V
VDD33 to GND	V_{DD33}		3.0	3.3	3.6	V
VDDIO to GND	V_{DDIO}	VDDIO \geq VDD18(min)	1.6	1.8-3.3	3.6	V
VDD18 to GND	V_{DD18}		1.6	1.8	2.0	V
Input Voltage on Digital Pins (RESETB, STP, DIR, NXT, DATA[7:0])	V_I		0.0		V_{DDIO}	V
Voltage on Analog I/O Pins (DP, DM, ID, CPEN, CPEN),	$V_{I(I/O)}$		0.0		V_{DD33}	V
VBUS to GND	V_{VMAX}		0.0		5.5	V
Ambient Temperature	T_A		-40		85	C

USB3315

4.0 ELECTRICAL CHARACTERISTICS

The following conditions are assumed unless otherwise specified:

$V_{VBAT} = 3.1$ to 5.5 V; $V_{DD18} = 1.6$ to 2.0 V; $V_{DDIO} = 1.6$ to 2.0 V; $V_{SS} = 0$ V; $T_A = -40$ °C to $+85$ °C

The current for 3.3 V circuits is sourced at the VBAT pin, except when using an external 3.3 V supply as shown in Figure 5-5.

4.1 Operating Current

TABLE 4-1: ELECTRICAL CHARACTERISTICS: OPERATING CURRENT

Parameter	Symbol	Conditions	Min	Typ	Max	Units
Synchronous Mode Current (Default Configuration)	$I_{33AVG(SYNC)}$	Start-up sequence defined in Section 5.5.4 has completed.	5.0	5.5	8.0	mA
	$I_{18AVG(SYNC)}$		17.5	22.0	27.0	mA
	$I_{IOAVG(SYNC)}$		2.5	3.0	4.0	mA
Synchronous Mode Current (HS USB operation)	$I_{33AVG(HS)}$	Active USB Transfer	7.0	10.0	14.0	mA
	$I_{18AVG(HS)}$		23.0	28.0	34.0	mA
	$I_{IOAVG(HS)}$		2.5	3.0	4.0	mA
Synchronous Mode Current (FS/LS USB operation)	$I_{33AVG(FS)}$	Active USB Transfer	5.0	8.5	13.0	mA
	$I_{18AVG(FS)}$		19.0	22.0	27.0	mA
	$I_{IOAVG(FS)}$		2.5	3.0	4.0	mA
Serial Mode Current (FS/LS USB) Note 1	$I_{33AVG(FS_S)}$		5.0	5.5	7.0	mA
	$I_{18AVG(FS_S)}$		1.5	2.2	3.5	mA
	$I_{IOAVG(FS_S)}$				0.1	mA
USB UART Current Note 1	$I_{33AVG(UART)}$		5.0	5.5	7.0	mA
	$I_{18AVG(UART)}$		1.4	2.1	3.5	mA
	$I_{IOAVG(UART)}$				0.1	mA
Low Power Mode Note 2	$I_{DD33(LPM)}$	$V_{VBAT} = 4.2$ V $V_{DD18} = 1.8$ V $V_{DDIO} = 1.8$ V	14.0	20.0	25.0	μ A
	$I_{DD18(LPM)}$			0.3	10.0	μ A
	$I_{DDIO(LPM)}$				1.5	μ A
Standby Mode	$I_{DD33(RSTB)}$	RESETB = 0 $V_{VBAT} = 4.2$ V $V_{DD18} = 1.8$ V $V_{DDIO} = 1.8$ V	14.0	20.0	25.0	μ A
	$I_{DD18(RSTB)}$			0.3	10.0	μ A
	$I_{DDIO(RSTB)}$				1.5	μ A

Note 1: *ClockSuspendM* bit = 0.

Note 2: *SessEnd*, *VbusVId*, and *IdFloat* comparators disabled. STP Interface protection disabled.

4.2 CLKOUT Specifications

TABLE 4-2: ELECTRICAL CHARACTERISTICS: CLKOUT SPECIFICATIONS

Parameter	Symbol	Conditions	Min	Typ	Max	Units
Suspend Recovery Time Note 3	T_{START}			1.12	2.37	ms
CLKOUT Duty Cycle	DC_{CLKOUT}		45		55	%
REFCLK Duty Cycle	DC_{REFCLK}		20		80	%
REFCLK Frequency Accuracy	F_{REFCLK}		-500		+500	PPM

Note 3: The USB3315 uses the *AutoResume* feature, [Section 5.4](#), to allow a host start-up time of less than 1 ms.

4.3 ULPI Interface Timing

TABLE 4-3: ULPI INTERFACE TIMING

Parameter	Symbol	Min	Max	Units
Setup time (STP, data in)	T_{SC}, T_{SD}	5.0		ns
Hold time (STP, data in)	T_{HC}, T_{HD}	0.0		ns
Output delay (control out, 8-bit data out)	T_{DC}, T_{DD}	1.5	3.5	ns

Note: $V_{DDIO} = 1.6$ to 3.6 V; $V_{SS} = 0$ V; $T_A = -40$ °C to 85 °C; $C_{Load} = 10$ pF

USB3315

4.4 Digital IO Pins

TABLE 4-4: DIGITAL IO CHARACTERISTICS: RESETB, CLKOUT, STP, DIR, NXT, DATA[7:0] AND XI PINS

Parameter	Symbol	Conditions	Min	Typ	Max	Units
Low-Level Input Voltage	V_{IL}		V_{SS}		$0.4 * V_{DDIO}$	V
High-Level Input Voltage	V_{IH}		$0.68 * V_{DDIO}$		V_{DDIO}	V
High-Level Input Voltage REFCLK only	V_{IH}		$0.68 * V_{DD18}$		V_{DD33}	V
Clock High REFCLK only	T_{HIGH}		$0.3 * T_P$	$0.5 * T_P$	$0.7 * T_P$	
Clock Low REFCLK only	T_{LOW}		$0.3 * T_P$	$0.5 * T_P$	$0.7 * T_P$	
Low-Level Output Voltage	V_{OL}	$I_{OL} = 8 \text{ mA}$			0.4	V
High-Level Output Voltage	V_{OH}	$I_{OH} = -8 \text{ mA}$	$V_{DDIO} - 0.4$			V
High-Level Output Voltage CPEN Only	V_{OH}	$I_{OH} = -8 \text{ mA}$	$V_{DD33} - 0.4$			V
Input Leakage Current	I_{LI}				± 10	μA
Pin Capacitance	C_{pin}				4	pF
STP pull-up resistance	R_{STP}	<i>InterfaceProtectDisable = 0</i>	51	60	65	k Ω
DATA[7:0] pull-dn resistance	R_{DATA_PD}	ULPI Synchronous Mode	55	67	79	k Ω
CLKOUT External Drive	V_{IH_ED}	At start-up or following reset			$0.4 * V_{DDIO}$	V

FIGURE 4-1: EXTERNAL REFERENCE CLOCK

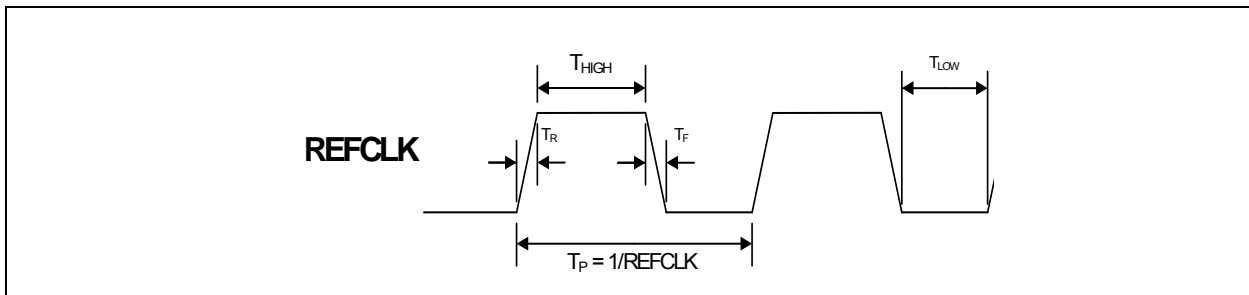

4.5 DC Characteristics: Analog I/O Pins

TABLE 4-5: DC CHARACTERISTICS: ANALOG I/O PINS (DP/DM)

Parameter	Symbol	Conditions	Min	Typ	Max	Units
LS/FS FUNCTIONALITY						
Input levels						
Differential Receiver Input Sensitivity	V_{DIFS}	$ V(DP) - V(DM) $	0.2			V
Differential Receiver Common-Mode Voltage	V_{CMFS}		0.8		2.5	V
Single-Ended Receiver Low Level Input Voltage	V_{ILSE}	Note 5			0.8	V
Single-Ended Receiver High Level Input Voltage	V_{IHSE}	Note 5	2.0			V
Single-Ended Receiver Hysteresis	V_{HYSSE}		0.050		0.150	V
Output Levels						
Low Level Output Voltage	V_{FSOL}	Pull-up resistor on DP; $R_L = 1.5\text{ k}\Omega$ to V_{DD33}			0.3	V
High Level Output Voltage	V_{FSOH}	Pull-down resistor on DP, DM; Note 5 $R_L = 15\text{ k}\Omega$ to GND	2.8		3.6	V
Termination						
Driver Output Impedance for HS and FS	Z_{HSDRV}	Steady state drive	40.5	45	49.5	Ω
Input Impedance	Z_{INP}	RX, RPU, RPD disabled	1.0			M Ω
Pull-up Resistor Impedance	R_{PU}	Bus Idle, Note 4	0.900	1.24	1.575	k Ω
Pull-up Resistor Impedance	R_{PU}	Device Receiving, Note 4	1.425	2.26	3.09	k Ω
Pull-dn Resistor Impedance	R_{PD}	Note 4	14.25	16.9	20	k Ω
Weak Pull-up Resistor Impedance	R_{CD}	Configured by bits 4 and 5 in USB IO & Power Management register.	128	170	212	k Ω
HS FUNCTIONALITY						
Input levels						
HS Differential Input Sensitivity	V_{DIHS}	$ V(DP) - V(DM) $	100			mV
HS Data Signaling Common Mode Voltage Range	V_{CMHS}		-50		500	mV
High-Speed Squelch Detection Threshold (Differential Signal Amplitude)	V_{HSSQ}	Note 6	100		150	mV
Output Levels						

USB3315

TABLE 4-5: DC CHARACTERISTICS: ANALOG I/O PINS (DP/DM) (CONTINUED)

Parameter	Symbol	Conditions	Min	Typ	Max	Units
Hi-Speed Low Level Output Voltage (DP/DM referenced to GND)	V_{HSOL}	45 Ω load	-10		10	mV
Hi-Speed High Level Output Voltage (DP/DM referenced to GND)	V_{HSOH}	45 Ω load	360		440	mV
Hi-Speed IDLE Level Output Voltage (DP/DM referenced to GND)	V_{OLHS}	45 Ω load	-10		10	mV
Chirp-J Output Voltage (Differential)	V_{CHIRPJ}	HS termination resistor disabled, pull-up resistor connected. 45 Ω load.	700		1100	mV
Chirp-K Output Voltage (Differential)	V_{CHIRPK}	HS termination resistor disabled, pull-up resistor connected. 45 Ω load.	-900		-500	mV
Leakage Current						
OFF-State Leakage Current	I_{LZ}				± 10	μA
Port Capacitance						
Transceiver Input Capacitance	C_{IN}	Pin to GND		5	10	pF

Note 4: The resistor value follows the 27% Resistor ECN published by the USB-IF.

Note 5: The values shown are valid when the *USB RegOutput* bits in the [USB IO & Power Management](#) register are set to the default value.

Note 6: An automatic waiver up to 200 mV is granted to accommodate system-level elements such as measurement/test fixtures, captive cables, EMI components, and ESD suppression.

4.6 Dynamic Characteristics: Analog I/O Pins

TABLE 4-6: DYNAMIC CHARACTERISTICS: ANALOG I/O PINS (DP/DM)

Parameter	Symbol	Conditions	Min	Typ	Max	Units
FS Output Driver Timing						
FS Rise Time	T_{FR}	$C_L = 50 \text{ pF}$; 10 to 90% of $ V_{OH} - V_{OL} $	4		20	ns
FS Fall Time	T_{FF}	$C_L = 50 \text{ pF}$; 10 to 90% of $ V_{OH} - V_{OL} $	4		20	ns
Output Signal Crossover Voltage	V_{CRS}	Excluding the first transition from IDLE state	1.3		2.0	V
Differential Rise/Fall Time Matching	T_{FRFM}	Excluding the first transition from IDLE state	90		111.1	%
LS Output Driver Timing						
LS Rise Time	T_{LR}	$C_L = 50\text{-}600 \text{ pF}$; 10 to 90% of $ V_{OH} - V_{OL} $	75		300	ns
LS Fall Time	T_{LF}	$C_L = 50\text{-}600 \text{ pF}$; 10 to 90% of $ V_{OH} - V_{OL} $	75		300	ns
Differential Rise/Fall Time Matching	T_{LRFM}	Excluding the first transition from IDLE state	80		125	%
HS Output Driver Timing						
Differential Rise Time	T_{HSR}		500			ps
Differential Fall Time	T_{HSF}		500			ps
Driver Waveform Requirements		Eye pattern of Template 1 in USB 2.0 specification				
Hi-Speed Mode Timing						
Receiver Waveform Requirements		Eye pattern of Template 4 in USB 2.0 specification				
Data Source Jitter and Receiver Jitter Tolerance		Eye pattern of Template 4 in USB 2.0 specification				

USB3315

4.7 OTG Electrical Characteristics

TABLE 4-7: OTG ELECTRICAL CHARACTERISTICS

Parameter	Symbol	Conditions	Min	Typ	Max	Units
SessEnd trip point	$V_{SessEnd}$		0.2	0.5	0.8	V
SessVId trip point	$V_{SessVId}$		0.8	1.4	2.0	V
VbusVId trip point	$V_{VbusVId}$		4.4	4.58	4.75	V
A-Device Impedance	R_{IdGnd}	Maximum A device Impedance to ground on ID pin			100	k Ω
ID Float trip point	$V_{IdFloat}$		1.9	2.2	2.5	V
Vbus Pull-Up	R_{VPU}	VBUS to VDD33 (<i>ChargeVbus = 1</i>)	281	340	450	Ω
Vbus Pull-down	R_{VPD}	VBUS to GND (<i>DisChargeVbus = 1</i>)	656	850	1100	Ω
Vbus Impedance	R_{VB}	VBUS to GND	40	75	100	k Ω
ID pull-up resistance	R_{ID}	<i>IdPullup = 1</i>	80	100	120	k Ω
ID weak pull-up resistance	R_{IDW}	<i>IdPullup = 0</i>	1			M Ω
ID pull-dn resistance	R_{IDPD}	<i>IdGndDrv = 1</i>			1000	Ω

4.8 Regulator Output Voltages and Capacitor Requirement

TABLE 4-8: REGULATOR OUTPUT VOLTAGES AND CAPACITOR REQUIREMENT

Parameter	Symbol	Conditions	Min	Typ	Max	Units
Regulator Output Voltage	V _{DD33}	6 V > V _{BAT} > 3.1 V	3.0	3.3	3.6	V
Regulator Output Voltage	V _{DD33}	USB UART Mode & <i>UART RegOutput[1:0] = 01</i> 6 V > V _{BAT} > 3.1 V	2.7	3.0	3.3	V
Regulator Output Voltage	V _{DD33}	USB UART Mode & <i>UART RegOutput[1:0] = 10</i> 6 V > V _{BAT} > 3.1 V	2.47	2.75	3.03	V
Regulator Output Voltage	V _{DD33}	USB UART Mode & <i>UART RegOutput[1:0] = 11</i> 6 V > V _{BAT} > 3.1 V	2.25	2.5	2.75	V
Regulator Bypass Capacitor	C _{BYP}		2.2			μF
Bypass Capacitor ESR	C _{ESR}				1	Ω

TABLE 4-9: ESD AND LATCH-UP PERFORMANCE

Parameter	Conditions	Min	Typ	Max	Units	Comments
ESD PERFORMANCE						
Note 7	Human Body Model			±8	kV	Device
System	EN/IEC 61000-4-2 Contact Discharge			±8	kV	3rd party system test
System	EN/IEC 61000-4-2 Air-gap Discharge			±15	kV	3rd party system test
LATCH-UP PERFORMANCE						
All Pins	EIA/JESD 78, Class II		150		mA	

Note 7: REFCLK pin ±5 kV Human Body Model.

5.2.2 TERMINATION RESISTORS

The USB3315 transceiver fully integrates all of the USB termination resistors on both **DP** and **DM**. This includes 1.5 kΩ pull-up resistors, 15 kΩ pull-down resistors and the 45 Ω high speed termination resistors. These resistors require no tuning or trimming by the Link. The state of the resistors is determined by the operating mode of the PHY when operating in synchronous mode.

The *XcvrSelect[1:0]*, *TermSelect* and *OpMode[1:0]* bits in the **Function Control** register, and the *DpPullDown* and *DmPullDown* bits in the **OTG Control** register control the configuration. The possible valid resistor combinations are shown in **Table 5-1**, and operation is guaranteed in only the configurations shown. If a ULPI Register Setting is configured that does not match a setting in the table, the transceiver operation is not guaranteed and the settings in the last row of **Table 5-1** will be used.

- RPU_DP_EN activates the 1.5 kΩ DP pull-up resistor
- RPU_DM_EN activates the 1.5 kΩ DM pull-up resistor
- RPD_DP_EN activates the 15 kΩ DP pull-down resistor
- RPD_DM_EN activates the 15 kΩ DM pull-down resistor
- HSTERM_EN activates the 45 Ω DP and DM high speed termination resistors

The USB3315 also includes two 125 kΩ **DP** and **DM** pull-up resistors described in **Section 5.8**.

TABLE 5-1: DP/DM TERMINATION VS. SIGNALING MODE

Signaling Mode	ULPI Register Settings					USB3315 Termination Resistor Settings				
	XcvrSelect[1:0]	TermSelect	OpMode[1:0]	DPPullDown	DMPullDown	RPU_DP_EN	RPU_DM_EN	RPD_DP_EN	RPD_DM_EN	HSTERM_EN
General Settings										
Tri-State Drivers	XXb	Xb	01b	Xb	Xb	0b	0b	0b	0b	0b
Power-up or Vbus < V _{SESEND}	01b	0b	00b	1b	1b	0b	0b	1b	1b	0b
Host Settings										
Host Chirp	00b	0b	10b	1b	1b	0b	0b	1b	1b	1b
Host Hi-Speed	00b	0b	00b	1b	1b	0b	0b	1b	1b	1b
Host Full Speed	X1b	1b	00b	1b	1b	0b	0b	1b	1b	0b
Host HS/FS Suspend	01b	1b	00b	1b	1b	0b	0b	1b	1b	0b
Host HS/FS Resume	01b	1b	10b	1b	1b	0b	0b	1b	1b	0b
Host low Speed	10b	1b	00b	1b	1b	0b	0b	1b	1b	0b
Host LS Suspend	10b	1b	00b	1b	1b	0b	0b	1b	1b	0b
Host LS Resume	10b	1b	10b	1b	1b	0b	0b	1b	1b	0b
Host Test J/Test_K	00b	0b	10b	1b	1b	0b	0b	1b	1b	1b
Peripheral Settings										
Peripheral Chirp	00b	1b	10b	0b	0b	1b	0b	0b	0b	0b
Peripheral HS	00b	0b	00b	0b	0b	0b	0b	0b	0b	1b

USB3315

TABLE 5-1: DP/DM TERMINATION VS. SIGNALING MODE (CONTINUED)

Signaling Mode	ULPI Register Settings					USB3315 Termination Resistor Settings				
	XcvrSelect[1:0]	TermSelect	OpMode[1:0]	DPPullDown	DMPullDown	RPU_DP_EN	RPU_DM_EN	RPD_DP_EN	RPD_DM_EN	HSTERM_EN
Peripheral FS	01b	1b	00b	0b	0b	1b	0b	0b	0b	0b
Peripheral HS/FS Suspend	01b	1b	00b	0b	0b	1b	0b	0b	0b	0b
Peripheral HS/FS Resume	01b	1b	10b	0b	0b	1b	0b	0b	0b	0b
Peripheral LS	10b	1b	00b	0b	0b	0b	1b	0b	0b	0b
Peripheral LS Suspend	10b	1b	00b	0b	0b	0b	1b	0b	0b	0b
Peripheral LS Resume	10b	1b	10b	0b	0b	0b	1b	0b	0b	0b
Peripheral Test J/Test K	00b	0b	10b	0b	0b	0b	0b	0b	0b	1b
OTG device, Peripheral Chirp	00b	1b	10b	0b	1b	1b	0b	0b	1b	0b
OTG device, Peripheral HS	00b	0b	00b	0b	1b	0b	0b	0b	1b	1b
OTG device, Peripheral FS	01b	1b	00b	0b	1b	1b	0b	0b	1b	0b
OTG device, Peripheral HS/FS Suspend	01b	1b	00b	0b	1b	1b	0b	0b	1b	0b
OTG device, Peripheral HS/FS Resume	01b	1b	10b	0b	1b	1b	0b	0b	1b	0b
OTG device, Peripheral Test J/Test K	00b	0b	10b	0b	1b	0b	0b	0b	1b	1b
Any combination not defined above Note 1:						0b	0b	0b	0b	0b

Note: This is the same as Table 40, Section 4.4 of the ULPI 1.1 specification.

Note: USB3315 does not support operation as an upstream hub port. See [Section 6.2.4.3](#).

Note 1: The transceiver operation is not guaranteed in a combination that is not defined.

The USB3315 uses the 27% resistor ECN resistor tolerances. The resistor values are shown in [Table 4-5](#).

5.3 Bias Generator

This block consists of an internal bandgap reference circuit used for generating the driver current and the biasing of the analog circuits. This block requires an external 8.06 k Ω , 1% tolerance, reference resistor connected from **RBIAS** to ground. This resistor should be placed as close as possible to the USB3315 to minimize the trace length. The nominal voltage at **RBIAS** is 0.8 V and therefore the resistor will dissipate approximately 80 μ W of power.

5.4 Integrated Low Jitter PLL

The USB3315 uses an integrated low jitter phase locked loop (PLL) to provide a clean 480 MHz clock. This clock is used by the PHY during both transmit and receive. The USB3315 requires a 24 MHz reference clock to be driven on the **REFCLK** pin.

After the PLL has locked to the correct frequency, the USB3315 will de-assert **DIR** and the Link can begin using the ULPI interface. The USB3315 is guaranteed to start the clock within the time specified in [Table 4-2](#). For Host applications, the ULPI *AutoResume* bit should be enabled. This is described in [Section 6.2.4.4](#).

The system must not drive voltage on the CLKOUT pin following POR or hardware reset that exceeds the value of V_{IH_ED} provided in [Table 4-4](#).

5.4.1 REFERENCE CLOCK REQUIREMENTS

The reference clock is connected to the REFCLK pins as shown in the application diagram, [Figure 8-1](#). The REFCLK pin is designed to be driven with a square wave from 0 V to V_{DDIO} , but can be driven with a square wave from 0 V to as high as 3.6 V.

When using an external reference clock, the USB3315 only uses the positive edge of the clock. The signal must comply with the V_{IH} and V_{IL} parameters provided in [Table 4-4](#). It may be possible to AC couple the reference clock to change the common-mode voltage level when it is sourced by a device that does not comply with the V_{IH} and V_{IL} parameters. A DC bias network must be provided at the REFCLK pin when the reference clock is AC coupled. The component values provided in [Figure 5-2](#) are for example only. The actual values should be selected to satisfy system requirements.

FIGURE 5-2: EXAMPLE OF CIRCUIT USED TO SHIFT A REFERENCE CLOCK COMMON-MODE VOLTAGE LEVEL

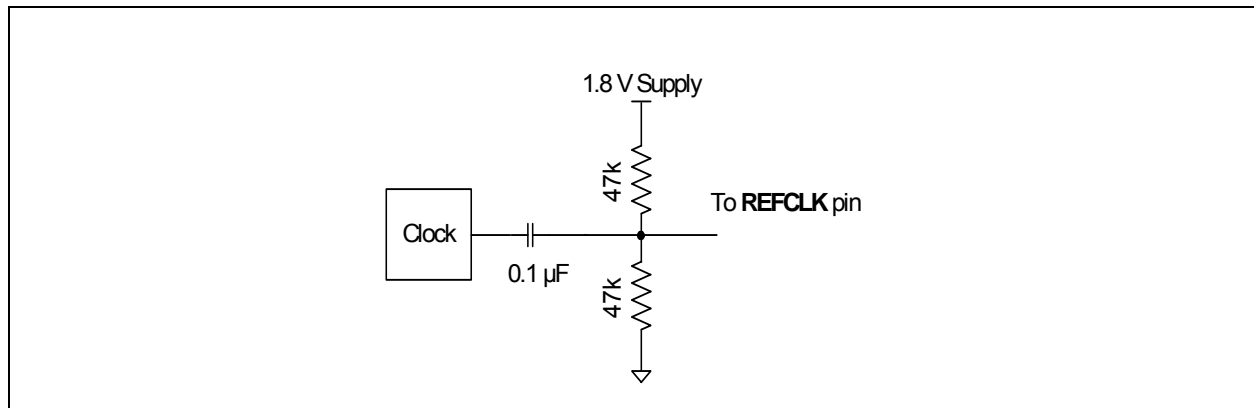

The jitter of the reference clock at certain frequencies can directly affect the HS eye diagram. The USB3315 is tolerant to reference clock jitter below 100 kHz and jitter above 4 MHz. If the REFCLK contains jitter in the 100 kHz to 4 MHz band the peak to peak amplitude of this jitter should be limited to 250 ps peak to peak. This requirement is illustrated in [Figure 5-3](#) below.

USB3315

FIGURE 5-3: USB3315 ALLOWABLE REFCLK JITTER VS. FREQUENCY

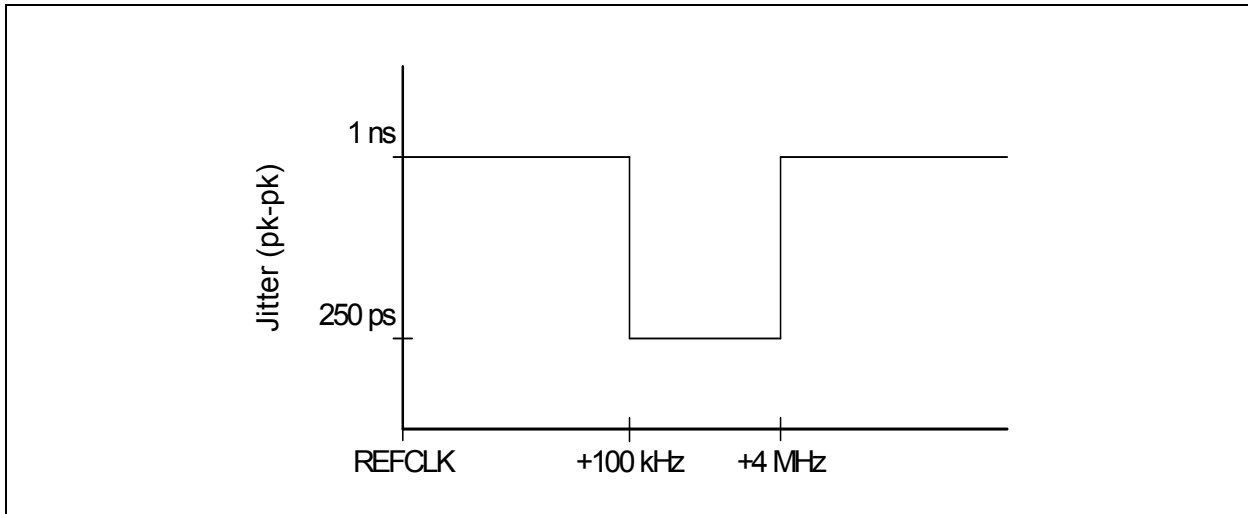

The edges of the reference clock do not need to be aligned in any way to the ULPI interface signals. The reference clock is used by a PLL to generate the 60 MHz CLKOUT for the ULPI digital. There is no need to align the phase of the REFCLK and the 60 MHz CLKOUT.

The REFCLK should be enabled when the RESETB pin is brought high. The ULPI interface will start running after the time specified in [Table 4-2](#). If the REFCLK enable is delayed relative to the RESETB pin, the ULPI interface will start operation delayed by the same amount. The REFCLK can be run at anytime the RESETB pin is low without causing the USB3315 to start-up or draw current.

When the USB3315 is placed in Low Power Mode or carkit mode the REFCLK can be stopped after the final ULPI register write is complete. The STP pin is asserted to bring the USB3315 out of Low Power Mode. The REFCLK should be started at the same time STP is asserted to minimize the USB3315 start-up time.

If the REFCLK is stopped while CLKOUT is running the PLL will come out of lock and the frequency of the CLKOUT signal will decrease to the minimum allowed by the PLL design. If the REFCLK is stopped during a USB session the session may drop.

5.5 Internal Regulators and POR

The USB3315 includes integrated power management functions, including a Low-Dropout regulator that can be used to generate the 3.3 V USB supply, and a POR generator.

5.5.1 INTEGRATED LOW DROPOUT REGULATOR

The USB3315 has an integrated linear regulator. Power sourced at the **VBAT** pin is regulated to 3.3 V and the regulator output is on the **VDD33** pin. To ensure stability, the regulator requires an external bypass capacitor as specified in [Table 4-8](#) placed as close to the pin as possible.

The USB3315 regulator is designed to generate a 3.3 V supply for the USB3315 only. Using the regulator to provide current for other circuits is not recommended and Microchip does not guarantee USB performance or regulator stability.

During USB UART mode the regulator output voltage can be changed to allow the USB3315 to work with UARTs operating at different operating voltages. The regulator output voltage is controlled by the *UART RegOutput[1:0]* bits described in [Section 7.1.4.4](#) and [Table 4-8](#).

The USB3315 regulator can be powered in the three methods as shown below.

For USB Peripheral, Host, and OTG operations the regulator can be connected as shown in [Figure 5-4](#) or [Figure 5-5](#) below. For OTG operation, the **VDD33** supply on the USB3315 must be powered to detect devices attaching to the USB connector and detect a SRP during an OTG session. When using a battery to supply the USB3315 the battery voltage must be within the range of 3.1 V to 5.5 V

FIGURE 5-4: POWERING THE USB3315 FROM A BATTERY

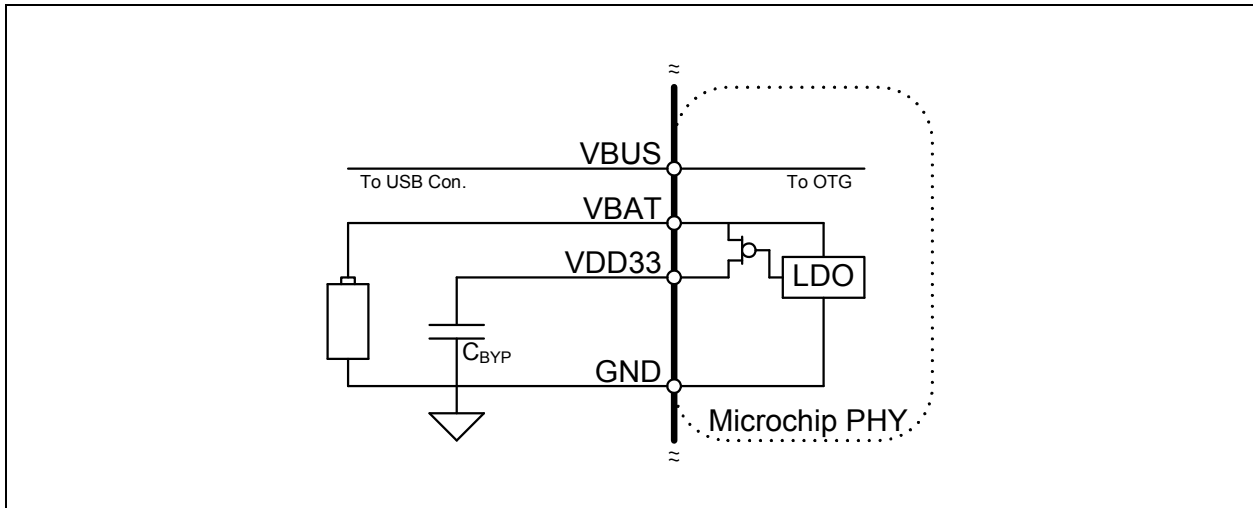

The USB3315 can be powered from an external 3.3 V supply as shown in [Figure 5-5](#). When using the external supply both the **VBAT** and **VDD33** pins are connected together. The bypass capacitor should be included when using the external supply.

FIGURE 5-5: POWERING THE USB3315 FROM A 3.3 V SUPPLY

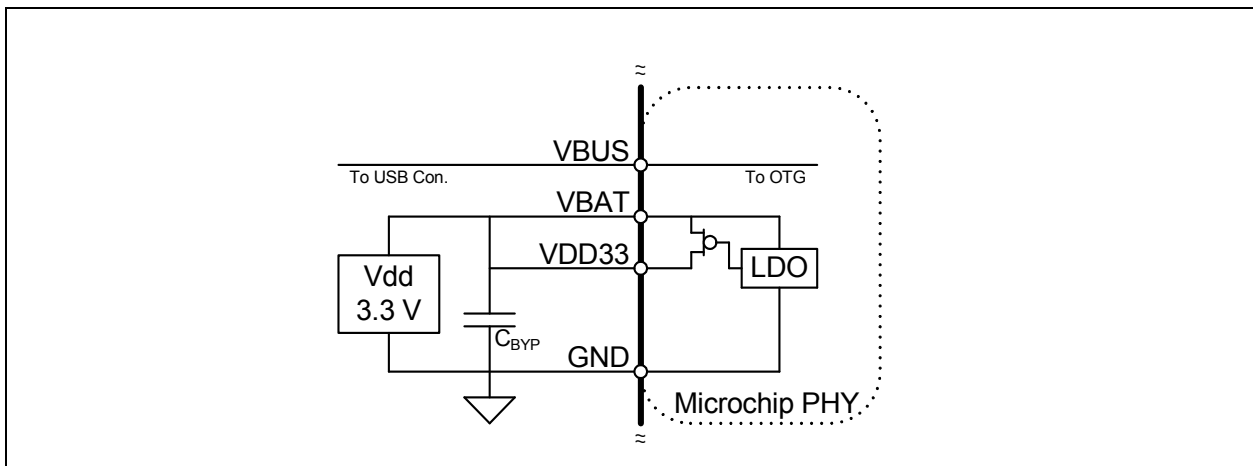

USB3315

For peripheral only or host only operation the regulator can be connected as shown in [Figure 5-6](#). This connection of the regulator requires the Vbus supply to be present any time the USB operation is desired. When a Vbus voltage is not present, the USB3315 cannot detect OTG or CarKit signaling.

FIGURE 5-6: POWERING THE USB3315 FROM THE USB CABLE VBUS

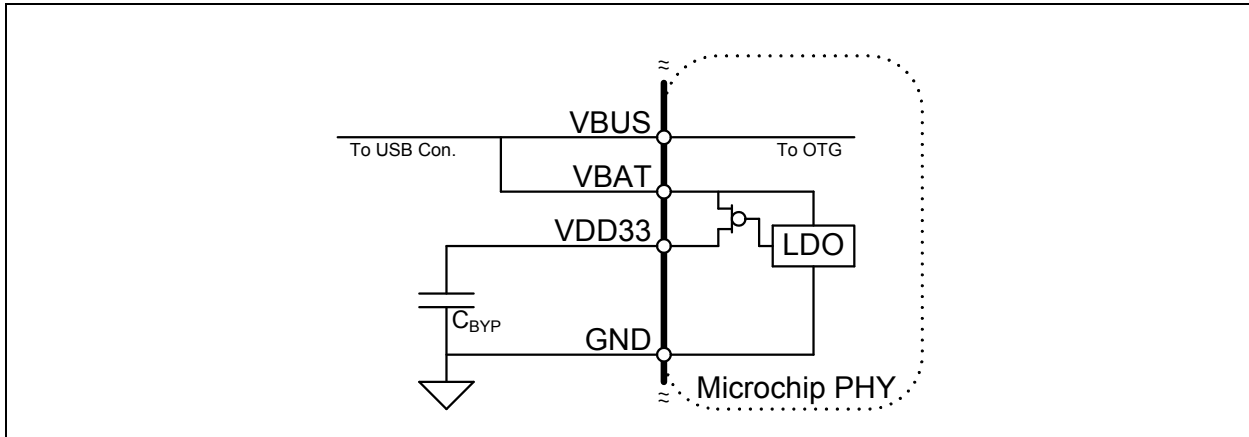

When using the USB3315 connected as shown in [Figure 5-6](#), the ULPI interface will operate when Vbus is removed. When Vbus is removed the USB3315 should be placed into Low Power Mode until Vbus is detected through an interrupt. While the USB3315 is in Low Power Mode the status of **VBUS**, **ID**, **DP**, and **DM** can be monitored while drawing a minimum amount of current from the **VDD18** supply as described in [Section 6.2.6.4](#).

5.5.2 POWER ON RESET (POR)

The USB3315 provides an internal POR circuit that generates a reset pulse after the **VDD18** supply is stable. After the internal POR goes high and the **RESETB** pin is high, the USB3315 will release from reset and begin normal ULPI operation. Provided that REFCLK is present when the **RESETB** pin is brought high, the ULPI bus will be available in the time defined as T_{START} as given in [Table 4-2](#).

The ULPI registers will power up in their default state summarized in [Table 7-1](#) when the 1.8 V supply is brought up. Cycling the 1.8 V power supply will reset the ULPI registers to their default states. The **RESETB** pin can also be used to reset the ULPI registers to their default state (and reset all internal state machines) by bringing the pin low for a minimum of 1 microsecond and then high.

The Link is not required to assert the **RESETB** pin. A pull-down resistor is not present on the **RESETB** pin and therefore the Link must drive the **RESETB** pin to the desired state at all times (including system start-up) or connect the **RESETB** pin to **VDDIO**.

5.5.3 RECOMMENDED POWER SUPPLY SEQUENCE

For USB operation the USB3315 requires the **VBAT**, **VDD33**, **VDD18**, and **VDDIO** supplies. The **VDDIO** supply should be powered up at the same time or after the **VDD18** supply is turned on and stable.

When the **VBAT** supply is applied the integrated regulator will automatically start-up and regulate **VBAT** to **VDD33**. If the **VDD33** supply is powered and the **VDD18** supply is not powered, the 3.3 V circuits are powered off and the **VDD33** current will be limited to 20 μ A.

The ULPI interface will start operating after the **VDD18** and **VDDIO** supplies are applied and the **RESETB** pin is brought high. The **RESETB** pin must be held low until the **VDD18** supply is stable. If the Link is not ready to interface the USB3315 the Link may choose to hold the **RESETB** pin low until it is ready to control the ULPI interface.

TABLE 5-2: OPERATING MODE VS. POWER SUPPLY CONFIGURATION

VDD33 (Note 2:)	VDD18	RESETB	Operating Modes Available
0	0	0	Powered Off
0	1	0	Standby Mode. VDD18 Current <1 μ A

TABLE 5-2: OPERATING MODE VS. POWER SUPPLY CONFIGURATION

VDD33 (Note 2)	VDD18	RESETB	Operating Modes Available
0	1	1	All operating modes described in Chapter 6.0 . Note: The USB3315 will only allow ULPI register access in this configuration.
1	1	1	Full USB operation as described in Chapter 6.0 .
1	0	X	In this mode the ULPI interface is not active and the circuits powered from the VDD33 are turned off and the current will be limited to 20 μ A.

Note 2: Anytime **VBAT** is powered the **VDD33** pin will be powered up. This column assumes the **VBAT** pin is powered as described above.

5.5.4 START-UP

The power on default state of the USB3315 is ULPI Synchronous mode. The USB3315 requires the following conditions to begin operation: the power supplies must be stable, the **REFCLK** must be present and the **RESETB** pin must be high. After these conditions are met, the USB3315 will begin ULPI operation that is described in [Section 6.1](#).

[Figure 5-7](#) below shows a timing diagram to illustrate the start-up of the USB3315. At T_0 , the supplies are stable and the USB3315 is held in reset mode. At T_1 , the Link drives **RESETB** high after the **REFCLK** has started. The **RESETB** pin may be brought high asynchronously to **REFCLK**. At this point the USB3315 will drive idle on the data bus and assert **DIR** until the internal PLL has locked. After the PLL has locked, the USB3315 will check that the Link has de-asserted **STP** and at T_2 it will de-assert **DIR** and begin ULPI operation.

The ULPI bus will be available as shown in [Figure 5-7](#) in the time defined as T_{START} given in [Table 4-2](#). If the **REFCLK** signal starts after the **RESETB** pin is brought high, then time T_0 will begin when **REFCLK** starts. T_{START} also assumes that the Link has de-asserted **STP**. If the Link has held **STP** high the USB3315 will hold **DIR** high until **STP** is de-asserted. When the LINK de-asserts **STP**, it must drive a ULPI IDLE one cycle after **DIR** de-asserts.

FIGURE 5-7: ULPI START-UP TIMING

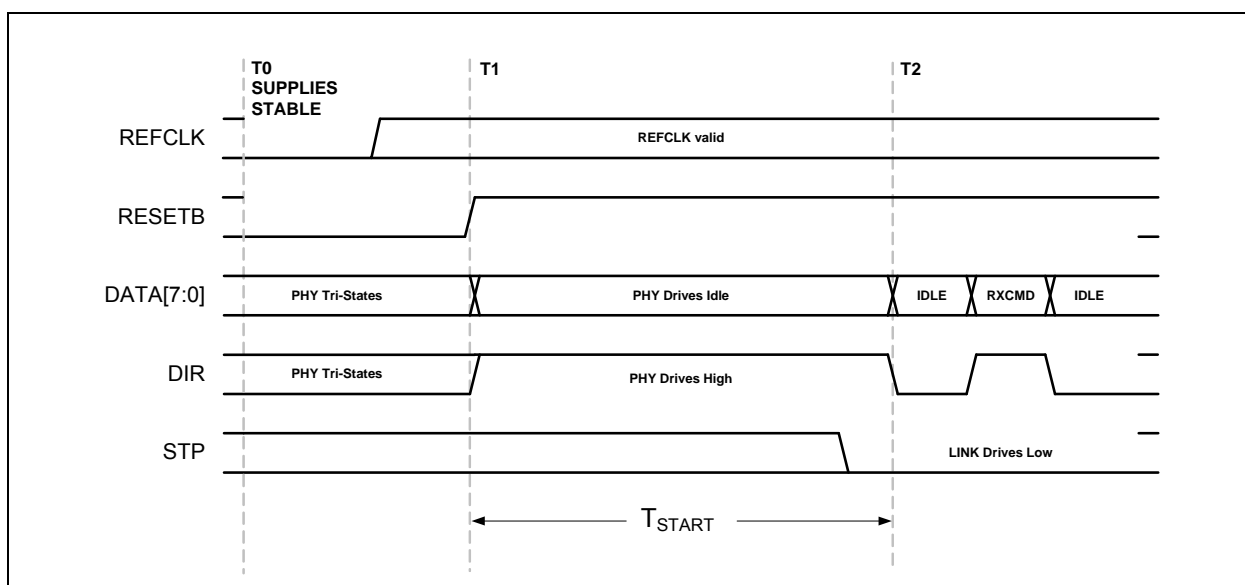

USB3315

5.6 USB On-The-Go (OTG)

The USB3315 provides full support for USB OTG protocol. OTG allows the USB3315 to be dynamically configured as a host or device depending on the type of cable inserted into the Micro-AB receptacle. When the Micro-A plug of a cable is inserted into the Micro-AB receptacle, the USB device becomes the A-device. When a Micro-B plug is inserted, the device becomes the B-device. The OTG A-device behaves similar to a Host while the B-device behaves similar to a peripheral. The differences are covered in the OTG the “On-The-Go Supplement to the USB 2.0 Specification”. In applications where only Host or Device is required, the OTG Module is unused.

The OTG Module is described in the following sections.

5.6.1 ID RESISTOR DETECTION

The ID pin of the USB connector is monitored by the ID pin of the USB3315 to detect the attachment of different types of USB devices and cables. The block diagram of the ID detection circuitry is shown in Figure 5-8 and the related parameters are given in Table 4-7.

FIGURE 5-8: USB3315 ID RESISTOR DETECTION CIRCUITRY

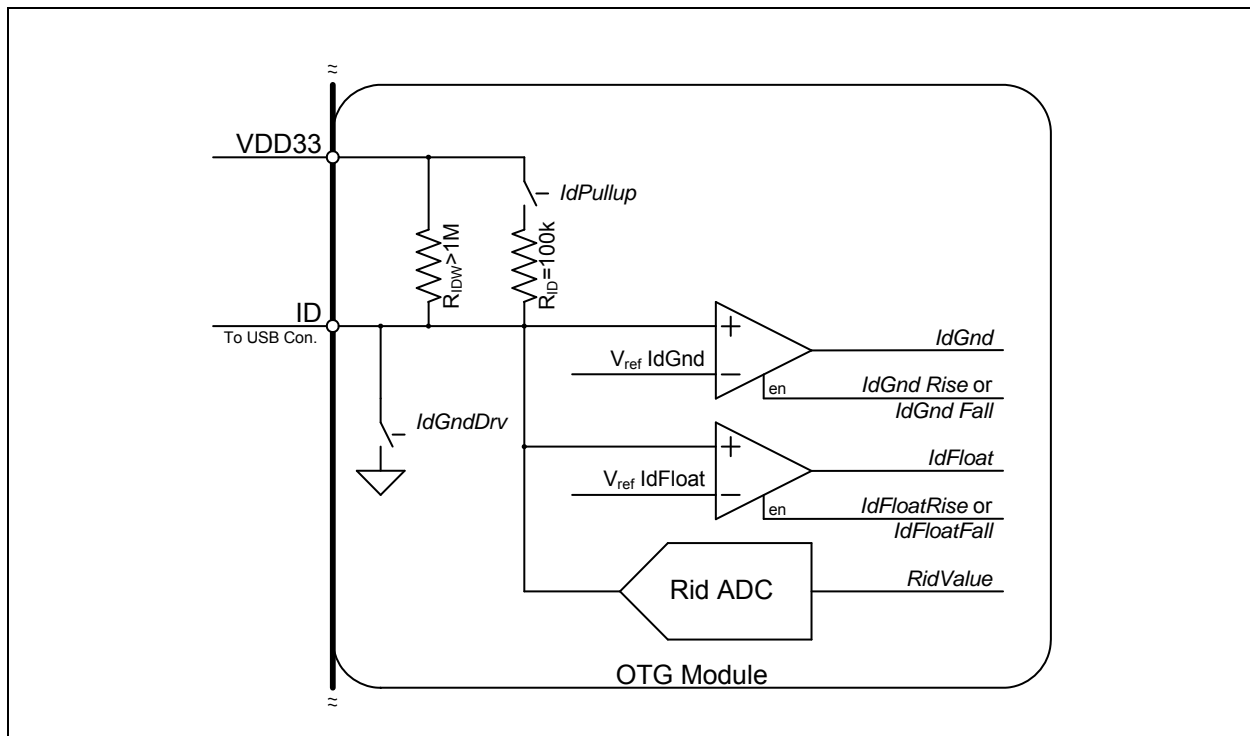

5.6.1.1 USB OTG Operation

The USB3315 can detect ID grounded and ID floating to determine if an A or B cable has been inserted. The A plug will ground the ID pin while the B plug will float the ID pin. These are the only two valid states allowed in the OTG Protocol.

To monitor the status of the ID pin, the Link activates the *IdPullup* bit in the **OTG Control** register, waits 50 ms and then reads the status of the *IdGnd* bit in the **USB Interrupt Status** register. If an A cable has been inserted the *IdGnd* bit will read 0. If a B cable is inserted, the ID pin is floating and the *IdGnd* bit will read 1.

The USB3315 provides an integrated weak pull-up resistor on the ID pin, R_{IDW} . This resistor is present to keep the ID pin in a known state when the *IdPullup* bit is disabled and the ID pin is floated. In addition to keeping the ID pin in a known state, it enables the USB3315 to generate an interrupt to inform the link when a cable with a resistor to ground has been attached to the ID pin. The weak pull-up is small enough that the largest valid Rid resistor pulls the ID pin low and causes the *IdGnd* comparator to go low.

After the link has detected an ID pin state change, the RID converter can be used to determine the resistor value as described in Section 5.6.1.2.

5.6.1.2 Measuring ID Resistance to Ground

The Link can use the integrated resistance measurement capabilities to determine the value of an ID resistance to ground. The following table details the valid values of resistance to ground that the USB3315 can detect.

TABLE 5-3: VALID VALUES OF ID RESISTANCE TO GROUND

ID Resistance to Ground	Rid Value
Ground	000
75 Ω +/-1%	001
102 k Ω +/-1%	010
200 k Ω +/-1%	011
440 k Ω +/-1%	100
Floating	101

Note: $IdPullup = 0$

The Rid resistance can be read while the USB3315 is in Synchronous Mode. When a resistor to ground is attached to the ID pin, the state of the IdGnd comparator will change. After the Link has detected ID transition to ground, it can use the methods described in [Section 6.5](#) to operate the Rid converter.

5.6.1.3 Using IdFloat Comparator (not recommended)

Note: The ULPI specification details a method to detect a 102 k Ω resistance to ground using the IdFloat comparator. This method can only detect 0 Ω , 102 k Ω , and floating terminations of the ID pin. Due to this limitation it is recommended to use the RID Converter as described in [Section 5.6.1.2](#).

The ID pin can be either grounded, floated, or connected to ground with a 102 k Ω external resistor. To detect the 102 k Ω resistor, set the *IdPullup* bit in the [OTG Control](#) register, causing the USB3315 to apply the 100 k Ω internal pull-up connected between the ID pin and VDD33. Set the *IdFloatRise* and *IdFloatFall* bits in both the [USB Interrupt Enable Rising](#) and [USB Interrupt Enable Falling](#) registers to enable the IdFloat comparator to generate an RXCMD to the Link when the state of the IdFloat changes. As described in [Figure 6-3](#), the alt_int bit of the RXCMD will be set. The values of IdGnd and IdFloat are shown for the three types cables that can attach to the USB Connector in [Table 5-4](#).

TABLE 5-4: IDGND AND IDFLOAT VS. ID RESISTANCE TO GROUND

ID Resistance	IdGnd	IdFloat
Float	0	1
102k	1	0
GND	1	0

Note: The ULPI register bits *IdPullup*, *IdFloatRise*, and *IdFloatFall* should be enabled.

To save current when an A Plug is inserted, the internal 102 k Ω pull-up resistor can be disabled by clearing the *IdPullup* bit in the [OTG Control](#) register and the *IdFloatRise* and *IdFloatFall* bits in both the [USB Interrupt Enable Rising](#) and [USB Interrupt Enable Falling](#) registers. If the cable is removed the weak R_{IDW} will pull the ID pin high.

The *IdGnd* value can be read using the ULPI [USB Interrupt Status](#) register, bit 4. In host mode, it can be set to generate an interrupt when *IdGnd* changes by setting the appropriate bits in the [USB Interrupt Enable Rising](#) and [USB Interrupt Enable Falling](#) registers. The *IdFloat* value can be read by reading the ULPI [Carkit Interrupt Status](#) register bit 0.

Note: The IdGnd switch has been provided to ground the ID pin for future applications.

USB3315

5.6.2 VBUS MONITOR AND PULSING

The USB3315 includes all of the Vbus comparators required for OTG. The VbusVld, SessVld, and SessEnd comparators shown in Figure 5-9 are fully integrated into the USB3315. These comparators are used to monitor changes in the Vbus voltage, and the state of each comparator can be read from the USB Interrupt Status register.

The VbusVld comparator is used by the Link, when configured as an A device, to ensure that the Vbus voltage on the cable is valid. The SessVld comparator is used by the Link when configured as both an A or B device to indicate a session is requested or valid. Finally the SessEnd comparator is used by the B-device to indicate a USB session has ended.

Also included in the VBUS Monitor and Pulsing block are the resistors used for Vbus pulsing in SRP. The resistors used for VBUS pulsing include a pull-down to ground and a pull-up to VDD33 as shown in Figure 5-9.

FIGURE 5-9: USB3315 OTG VBUS BLOCK

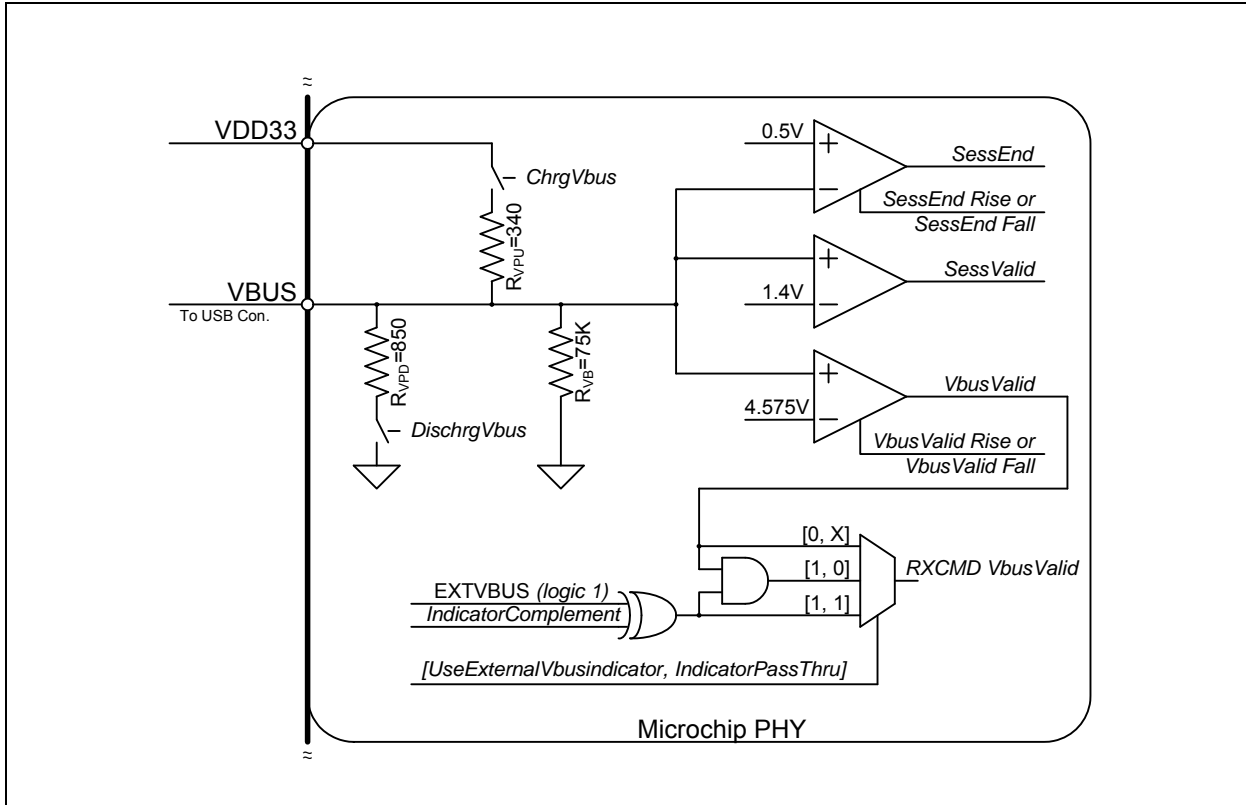

5.6.2.1 SessEnd Comparator

The SessEnd comparator is designed to trip when Vbus is less than 0.5 V. When Vbus goes below 0.5 V the USB session is considered to be ended, and SessEnd will transition from 0 to 1. The SessEnd comparator can be disabled by clearing this bit in both the USB Interrupt Enable Rising and USB Interrupt Enable Falling registers. When disabled, the SessEnd bit in the USB Interrupt Status register will read 0. The SessEnd comparator trip points are detailed in Table 4-7.

5.6.2.2 SessVld Comparator

The SessVld comparator is used when the PHY is configured as both an A and B device. When configured as an A device, the SessVld is used to detect Session Request protocol (SRP). When configured as a B device, SessVld is used to detect the presence of Vbus. The SessVld interrupts can be disabled by clearing this bit in both the USB Interrupt Enable Rising and USB Interrupt Enable Falling registers. When the interrupts are disabled, the SessVld comparator is not disabled and its state can be read in the USB Interrupt Status register. The SessVld comparator trip point is detailed in Table 4-7.

Note: The OTG Supplement specifies a voltage range for A-Device Session Valid and B-Device Session Valid comparator. The USB3315 PHY combines the two comparators into one and uses the narrower threshold range.

5.6.2.3 VbusVld Comparator

The final Vbus comparator is the VbusVld comparator. This comparator is only used when the USB3315 is configured as an A-device. In the USB protocol the A-device supplies the VBUS voltage and is responsible to ensure it remains within a specified voltage range. The VbusVld comparator can be disabled by clearing this bit in both the [USB Interrupt Enable Rising](#) and [USB Interrupt Enable Falling](#) registers. When disabled, bit 1 of the [USB Interrupt Status](#) register will return a 0. The VbusVld comparator trip points are detailed in [Table 4-7](#).

The internal VbusValid comparator is designed to ensure the Vbus voltage remains above 4.4 V.

The USB3315 includes the external Vbus valid indicator logic as detail in the ULPI Specification. The external Vbus valid indicator is tied to a logic one. The decoding of this logic is shown in [Table 5-5](#) below. By default this logic is disabled.

TABLE 5-5: EXTERNAL VBUS INDICATOR LOGIC

Typical Application	Use External VBus Indicator	Indicator Pass Thru	Indicator Complement	RXCMD Vbus Valid Encoding Source
OTG Device	0	X	X	Internal VbusVld comparator (Default)
	1	1	0	Fixed 1
	1	1	1	Fixed 0
	1	0	0	Internal VbusVld comparator.
	1	0	1	Fixed 0
Standard Host	1	1	0	Fixed 1
	1	1	1	Fixed 0
Standard Peripheral	0	X	X	Internal VbusVld comparator. This information should not be used by the Link. (Note 3 .)

Note 3: A peripheral should not use VbusVld to begin operation. The peripheral should use SessVld because the internal VbusVld threshold can be above the Vbus voltage required for USB peripheral operation.

5.6.2.4 Vbus Pulsing with Pull-up and Pull-down Resistors

In addition to the internal Vbus comparators, the USB3315 also includes the integrated Vbus pull-up and pull-down resistors used for Vbus Pulsing. To discharge the Vbus voltage so that a Session Request can begin, the USB3315 provides a pull-down resistor from Vbus to Ground. This resistor is controlled by the *DischargeVbus* bit 3 of the [OTG Control](#) register. The pull-up resistor is connected between Vbus and VDD33. This resistor is used to pull Vbus above 2.1 V so that the A-Device knows that a USB session has been requested. The state of the pull-up resistor is controlled by the bit 4 *ChargeVbus* of the [OTG Control](#) register. The Pull-Up and Pull-Down resistor values are detailed in [Table 4-7](#).

5.6.2.5 Vbus Input Impedance

The OTG Supplement requires an A-Device that supports Session Request Protocol to have a VBUS input impedance less than 100 kΩ and greater the 40 kΩ to ground. The USB3315 provides a 75 kΩ resistance to ground, R_{VB} . The R_{VB} resistor tolerance is detailed in [Table 4-7](#).

USB3315

5.6.3 DRIVING EXTERNAL VBUS

A system that is operating as a host is required to source 5 V on VBUS. The USB3315 fully supports VBUS power control using external devices. The USB3315 provides an active high control signal, **CPEN**, which is dedicated to controlling the Vbus supply when configured as an A-Device.

CPEN is asserted by setting the *DrvVbus* or *DrvVbusExternal* bit of the **OTG Control** register. To be compatible with Link designs that support both internal and external Vbus supplies the *DrvVbus* and *DrvVbusExternal* bits in the OTG Control Register are or'd together. This enables the Link to set either bit to access the external Vbus enable (**CPEN**.) This logic is shown in [Figure 5-10](#). *DrvVbus* and *DrvVbusExternal* are set to 0 on POR.

FIGURE 5-10: USB3315 DRIVES EXTERNAL VBUS SUPPLY OR SWITCH

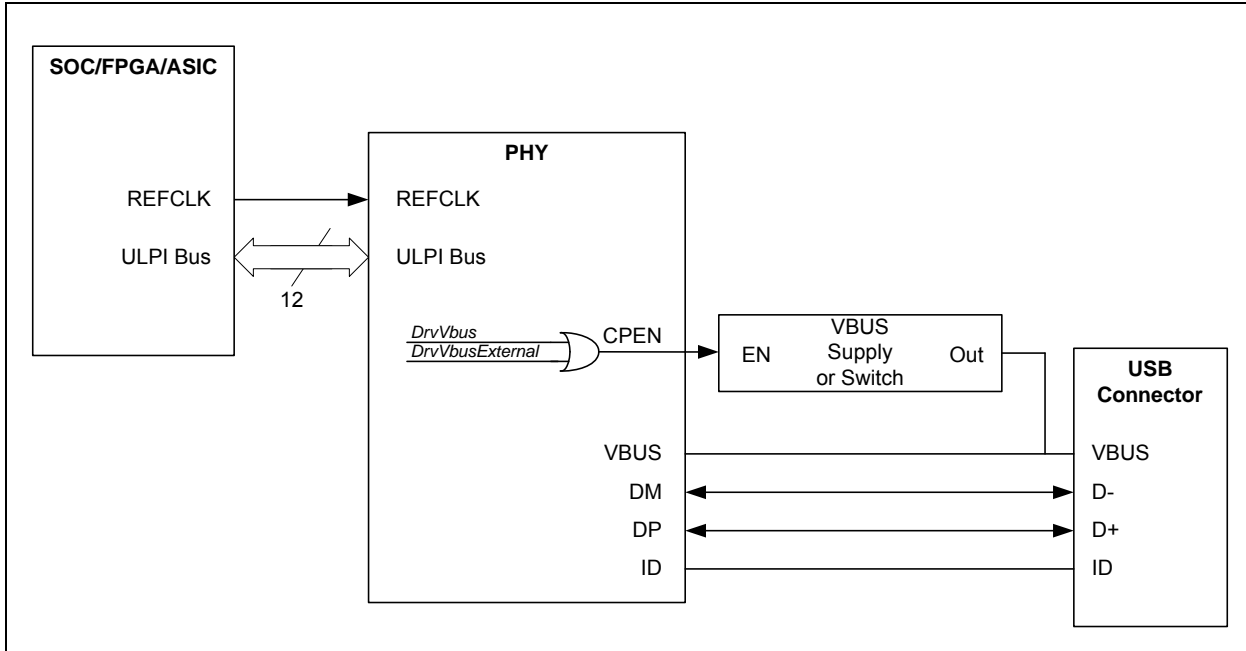

5.7 USB UART Support

The USB3315 provides support for the USB UART interface as detailed in the ULPI specification and the CEA-936A specification. The USB3315 can be placed in UART Mode using the method described in [Section 6.4](#), and the regulator output will automatically switch to the value configured by the *UART RegOutput* bits in the **USB IO & Power Management** register. While in UART mode, the Linestate signals cannot be monitored on the DATA[0] and DATA[1] pins.

5.8 USB Charger Detection Support

To support the detection and identification of different types of USB chargers the USB3315 provides integrated pull-up resistors, R_{CD} , on both DP and DM. These pull-up resistors along with the single ended receivers can be used to help determine the type of USB charger attached. Reference information on implementing charger detection is provided in [Section 8.2](#).

TABLE 5-6: USB WEAK PULL-UP ENABLE

RESETB	DP Pullup Enable	DM Pullup Enable
0	0	0
1	<i>ChargerPullupEnableDP</i>	<i>ChargerPullupEnableDM</i>

Note: *ChargerPullupEnableDP* and *ChargerPullupEnableDM* are enabled in the [USB IO & Power Management](#) register.

USB3315

6.0 ULPI OPERATION OVERVIEW

The USB3315 uses the industry standard ULPI digital interface to facilitate communication between the PHY and Link (device controller). The ULPI interface is designed to reduce the number of pins required to connect a discrete USB PHY to an ASIC or digital controller. For example, a full UTMI+ Level 3 OTG interface requires 54 signals while a ULPI interface requires only 12 signals.

The ULPI interface is documented completely in the “UTMI+ Low Pin Interface (ULPI) Specification Revision 1.1” (www.ulpi.org). The following sections highlight the key operating modes of the USB3315 digital interface.

6.1 Overview

Figure 6-1 illustrates the block diagram of the ULPI digital functions. It should be noted that this USB3315 does not use a “ULPI wrapper” around a UTMI+ PHY core as the ULPI specification implies.

FIGURE 6-1: ULPI DIGITAL BLOCK DIAGRAM

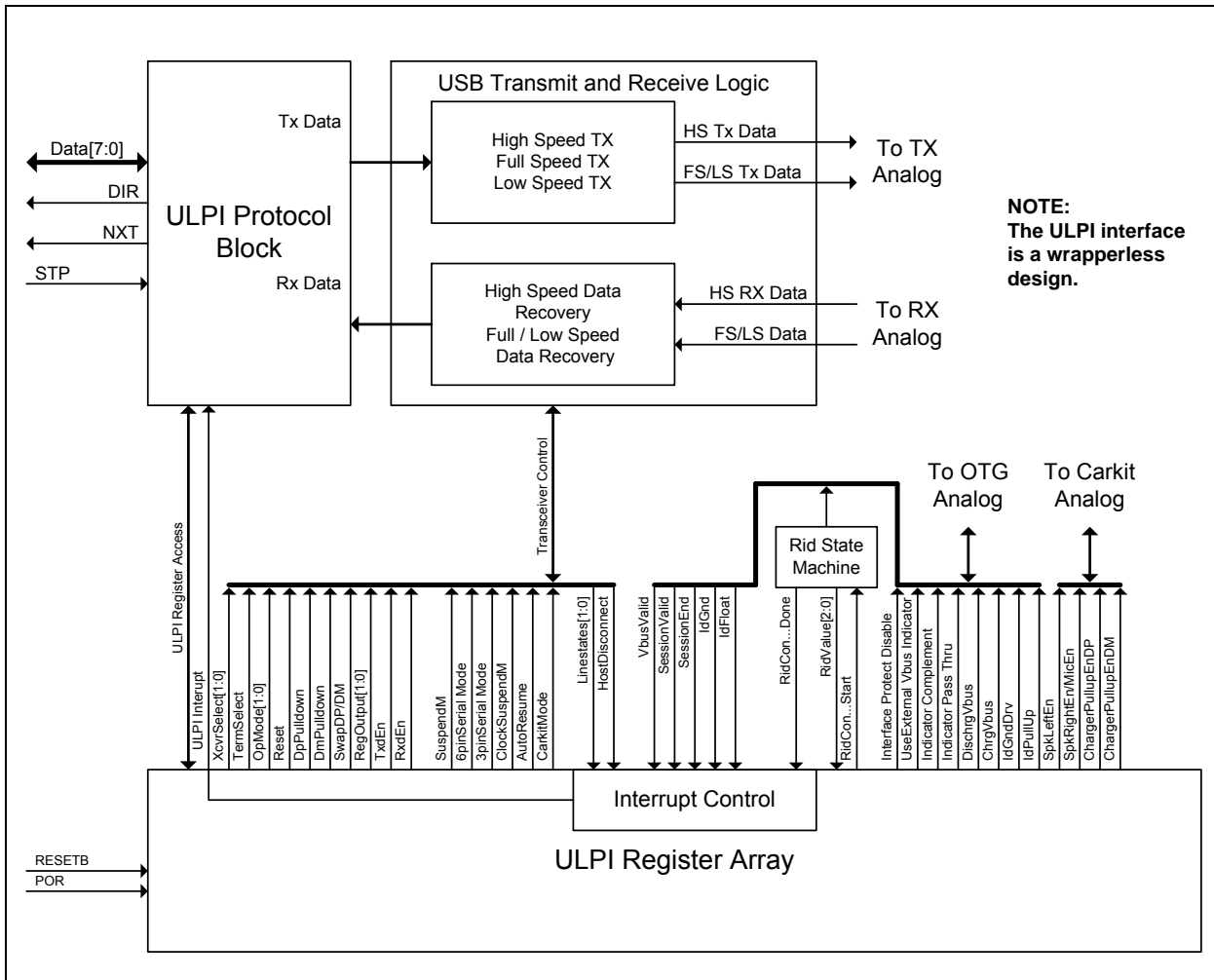

The advantage of a “wrapper less” architecture is that the USB3315 has a lower USB latency than a design which must first register signals into the PHY’s wrapper before the transfer to the PHY core. A low latency PHY allows a Link to use a wrapper around a UTMI Link and still make the required USB turn-around timing given in the USB 2.0 specification.

RxEndDelay maximum allowed by the UTMI+/ULPI for 8-bit data is 63 high speed clocks. USB3315 uses a low latency high speed receiver path to lower the RxEndDelay to 43 high speed clocks. This low latency design gives the Link more cycles to make decisions and reduces the Link complexity. This is the result of the “wrapper less” architecture of the USB3315. This low RxEndDelay should allow legacy UTMI Links to use a “wrapper” to convert the UTMI+ interface to a ULPI interface.

In [Figure 6-1](#), a single ULPI Protocol Block decodes the ULPI 8-bit bi-directional bus when the Link addresses the PHY. The Link must use the **DIR** output to determine direction of the ULPI data bus. The USB3315 is the “bus arbitrator”. The ULPI Protocol Block will route data/commands to the transmitter or the ULPI register array.

6.1.1 ULPI INTERFACE SIGNALS

The UTIM+ Low Pin Interface (ULPI) uses 12-pins to connect a full OTG Host / Device PHY to an SOC. A reduction of external pins on the PHY is accomplished by realizing that many of the relatively static configuration pins (XcvtSelect[1:0], TermSelect, OpMode[1:0], and DpPulldown, DmPulldown to list a few,) can be implemented by having an internal static register array.

An 8-bit bi-directional data bus clocked at 60 MHz allows the Link to access this internal register array and transfer USB packets to and from the PHY. The remaining 3 pins function to control the data flow and arbitrate the data bus.

Direction of the 8-bit data bus is controlled by the **DIR** output from the PHY. Another output, **NXT**, is used to control data flow into and out of the device. Finally, **STP**, which is in input to the PHY, terminates transfers and is used to start up and resume from Low Power Mode.

The 12 signals are described below in [Table 6-1](#).

TABLE 6-1: ULPI INTERFACE SIGNALS

Signal	Direction	Description
CLKOUT	OUT	60 MHz reference clock output. All ULPI signals are driven synchronous to the rising edge of this clock.
DATA[7:0]	I/O	8-bit bi-directional data bus. Bus ownership is determined by DIR. The Link and PHY initiate data transfers by driving a non-zero pattern onto the data bus. ULPI defines interface timing for a single-edge data transfers with respect to rising edge of CLKOUT .
DIR	OUT	Controls the direction of the data bus. When the PHY has data to transfer to the Link, it drives DIR high to take ownership of the bus. When the PHY has no data to transfer it drives DIR low and monitors the bus for commands from the Link. The PHY will pull DIR high whenever the interface cannot accept data from the Link, such as during PLL start-up.
STP	IN	The Link asserts STP for one clock cycle to stop the data stream currently on the bus. If the Link is sending data to the PHY, STP indicates the last byte of data was on the bus in the previous cycle.
NXT	OUT	The PHY asserts NXT to throttle the data. When the Link is sending data to the PHY, NXT indicates when the current byte has been accepted by the PHY. The Link places the next byte on the data bus in the following clock cycle.

USB3315 implements a Single Data Rate (SDR) ULPI interface with all data transfers happening on the rising edge of the **CLKOUT** signal supplied by the PHY.

The ULPI interface supports the two basic modes of operation: Synchronous Mode and Low Power Mode. In Synchronous Mode, all signals change synchronously with the 60 MHz CLKOUT. In Low Power Mode the clock is off and the lower two bits of the data bus contain the linestate[1:0] signals. Interrupt outputs are generated while in Low Power Mode to enable the Link to receive an asynchronous interrupt when the Linestate, Vbus state, or ID state changes.

Data is transferred on the rising edge of **CLKOUT** while operating in Synchronous Mode. The direction of the data bus is determined by the state of **DIR**. When **DIR** is high, the PHY is driving **DATA[7:0]**. When **DIR** is low, the Link is driving **DATA[7:0]**.

Each time DIR changes, a “turn-around” cycle occurs where neither the Link nor PHY drive the data bus for one clock cycle. During the “turn-around” cycle, the state of **DATA[7:0]** is unknown and the PHY will not read the data bus.

Because USB uses a bit-stuffing encoding, some means of allowing the PHY to throttle the USB transmit data is needed. The ULPI signal **NXT** is used to request the next byte to be placed on the data bus by the Link layer.

USB3315

6.1.2 ULPI INTERFACE TIMING IN SYNCHRONOUS MODE

The control and data timing relationships are given in Figure 6-2 and Table 4-3. The USB3315 provides CLKOUT and all timing is relative to the rising clock edge.

FIGURE 6-2: ULPI SINGLE DATA RATE TIMING DIAGRAM IN SYNCHRONOUS MODE

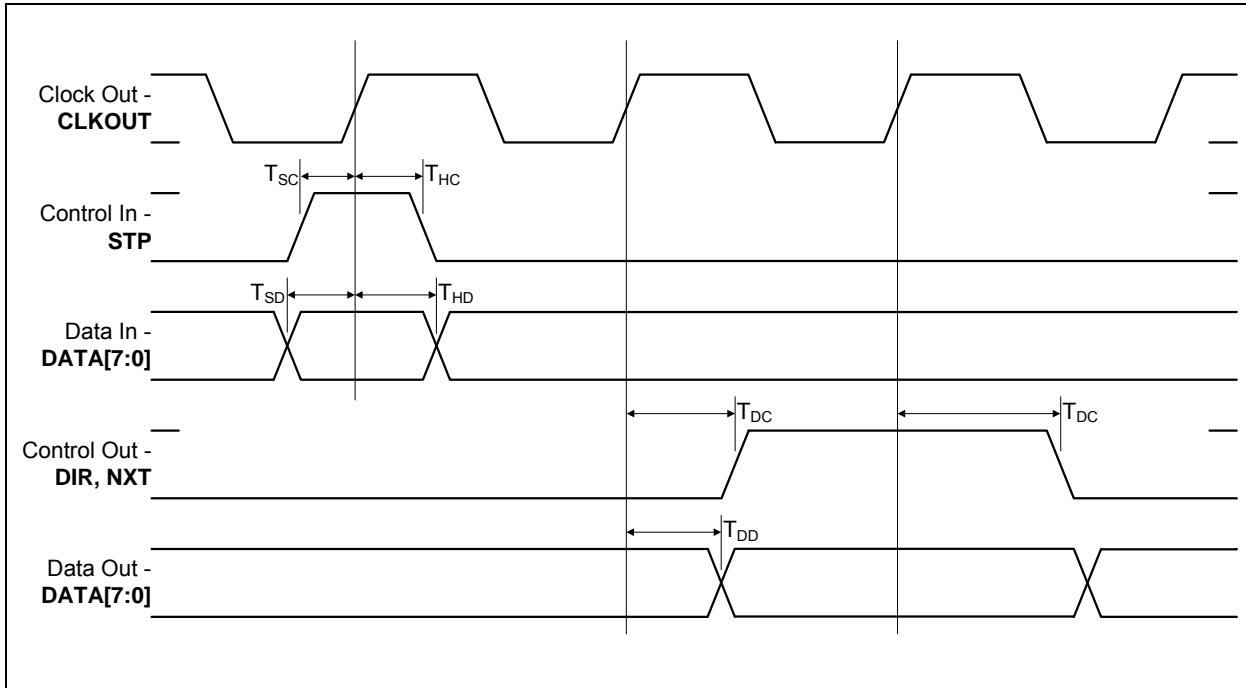

6.2 ULPI Register Access

A command from the Link begins a ULPI transfer from the Link to the USB3315. Before reading a ULPI register, the Link must wait until DIR is low, and then send a Transmit Command Byte (TXD CMD) byte. The TXD CMD byte informs the USB3315 of the type of data being sent. The TXD CMD is followed by a data transfer to or from the USB3315. Table 6-2 gives the TXD command byte (TXD CMD) encoding for the USB3315. The upper two bits of the TX CMD instruct the PHY as to what type of packet the Link is transmitting. The ULPI registers retain their contents when the PHY is in Low Power Mode, Full Speed/Low Speed Serial Mode, or CarKit Mode.

TABLE 6-2: ULPI TXD CMD BYTE ENCODING

Command Name	CMD Bits[7:6]	CMD Bits[5:0]	Command Description
Idle	00b	000000b	ULPI Idle
Transmit	01b	000000b	USB Transmit Packet with No Packet Identifier (NOPID)
		00XXXXb	USB Transmit Packet Identifier (PID) where DATA[3:0] is equal to the 4-bit PID. $P_3P_2P_1P_0$ where P_3 is the MSB.
Register Write	10b	XXXXXXb	Immediate Register Write Command where: DATA[5:0] = 6-bit register address
		101111b	Extended Register Write Command where the 8-bit register address is available on the next cycle.

TABLE 6-2: ULPI TXD CMD BYTE ENCODING

Command Name	CMD Bits[7:6]	CMD Bits[5:0]	Command Description
Register Read	11b	XXXXXXb	Immediate Register Read Command where: DATA[5:0] = 6-bit register address
		101111b	Extended Register Read Command where the 8-bit register address is available on the next cycle.

6.2.1 ULPI REGISTER WRITE

A ULPI register write operation is given in [Figure 6-3](#). The TXD command with a register write DATA[7:6] = 10b is driven by the Link at T0. The register address is encoded into **DATA[5:0]** of the TXD CMD byte.

FIGURE 6-3: ULPI REGISTER WRITE IN SYNCHRONOUS MODE

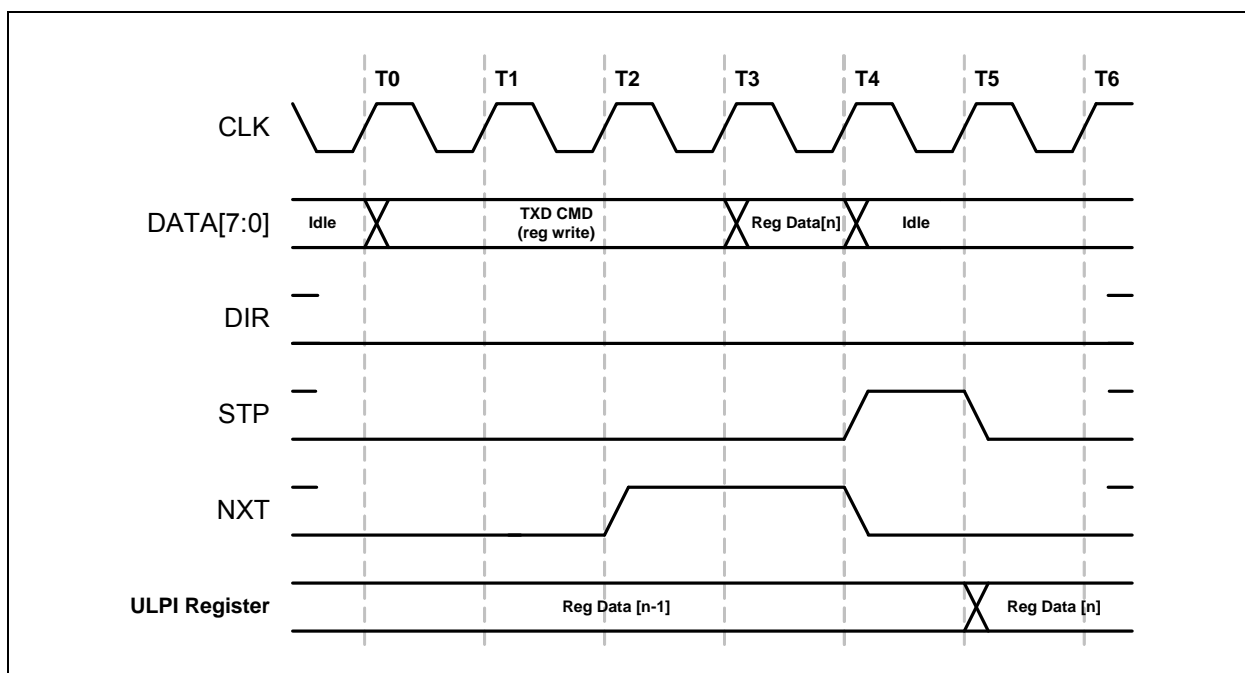

To write a register, the Link will wait until **DIR** is low, and at T0, drive the TXD CMD on the data bus. At T2 the PHY will drive **NXT** high. On the next rising clock edge, T3, the Link will write the register data. At T4, the PHY will accept the register data and the Link will drive an Idle on the bus and drive **STP** high to signal the end of the data packet. Finally, at T5, the PHY will latch the data into the register and drive **NXT** low. The Link will pull **STP** low.

NXT is used to control when the Link drives the register data on the bus. **DIR** is low throughout this transaction since the PHY is receiving data from the Link. **STP** is used to end the transaction and data is registered after the de-assertion of **STP**. After the write operation completes, the Link must drive a ULPI Idle (00h) on the data bus or the USB3315 may decode the bus value as a ULPI command.

A ULPI extended register write operation is shown in [Figure 6-4](#). To write an extended register, the Link will wait until **DIR** is low, and at T0, drive the TXD CMD on the data bus. At T2 the PHY will drive **NXT** high. On the next clock T3 the Link will drive the extended address. On the next rising clock edge, T4, the Link will write the register data. At T5, the PHY will accept the register data and drive **NXT** low. The Link will drive an Idle on the bus and drive **STP** high to signal the end of the data packet. Finally, at T5, the PHY will latch the data into the register. The Link will pull **STP** low.

FIGURE 6-4: ULPI EXTENDED REGISTER WRITE IN SYNCHRONOUS MODE

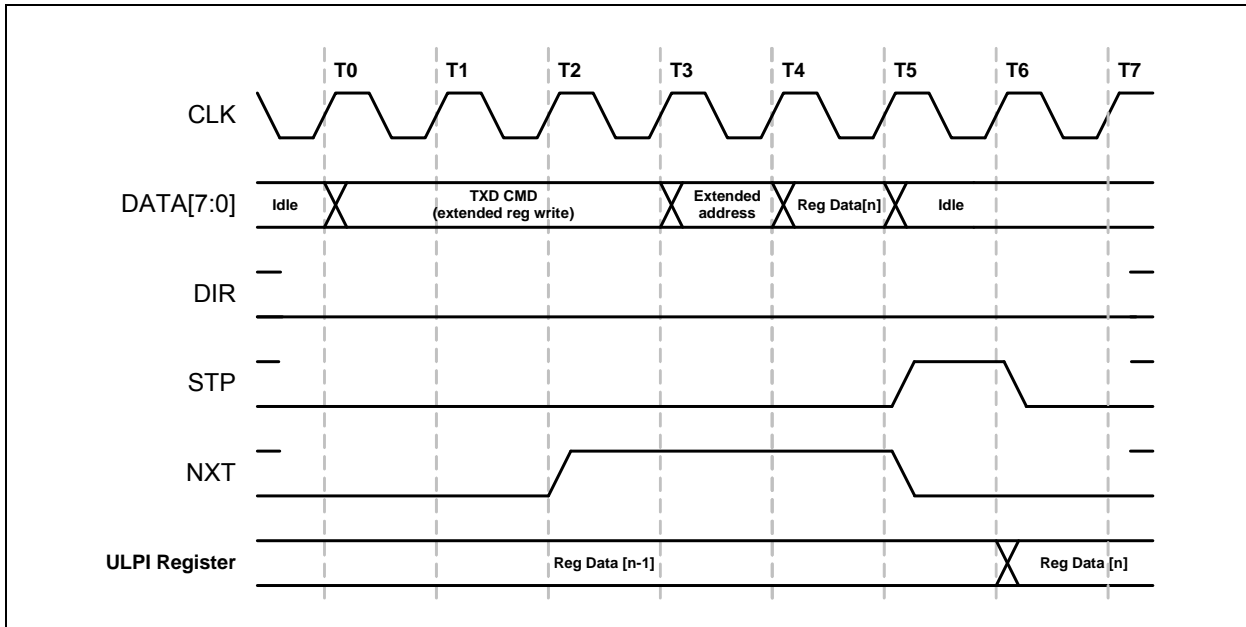

6.2.2 ULPI REGISTER READ

A ULPI register read operation is given in [Figure 6-5](#). The Link drives a TXD CMD byte with **DATA[7:6] = 11h** for a register read. **DATA[5:0]** of the ULPI TXD command byte contain the register address.

FIGURE 6-5: ULPI REGISTER READ IN SYNCHRONOUS MODE

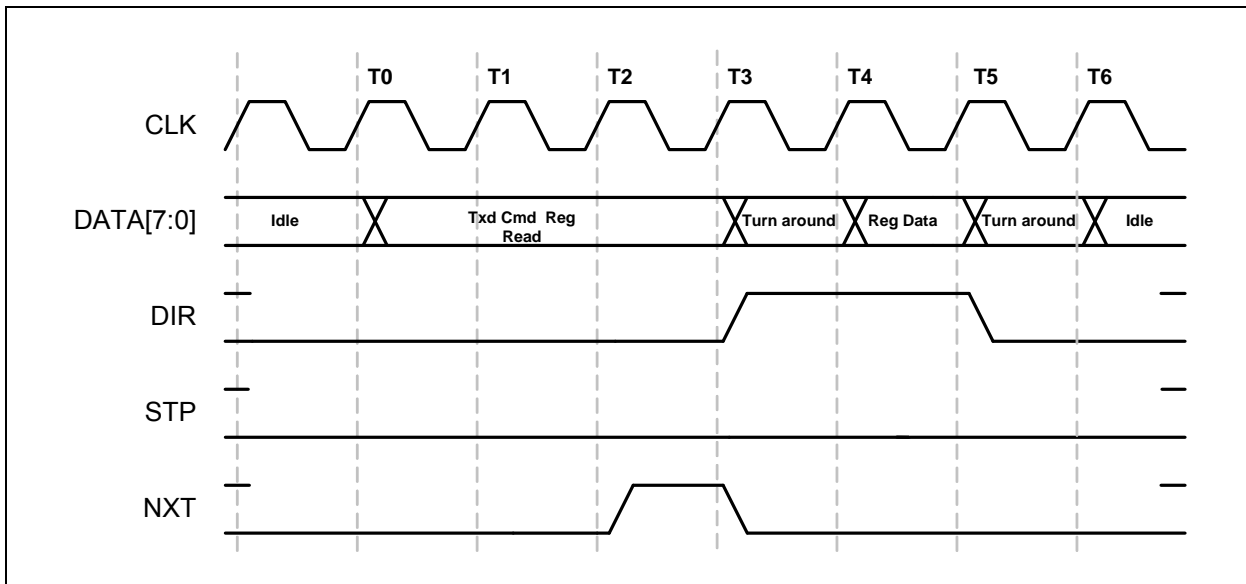

At T0, the Link will place the TXD CMD on the data bus. At T2, the PHY will bring **NXT** high, signaling that the Link is ready to accept the data transfer. At T3, the PHY reads the TXD CMD, determines it is a register read, and asserts **DIR** to gain control of the bus. The PHY will also de-assert **NXT**. At T4, the bus ownership has transferred back to the PHY and the PHY drives the requested register onto the data bus. At T5, the Link will read the data bus and the PHY will drop **DIR** low returning control of the bus back to the Link. After the turn around cycle, the Link must drive a ULPI Idle command at T6.

A ULPI extended register read operation is shown in Figure 6-6. To read an extended register, the Link writes the TX CMD with the address set to 2Fh. At T2, the PHY will assert **NXT**, signaling the Link it is ready to accept the extended address. At T3, the Link places the extended register address on the bus. At T4, the PHY reads the extended address, and asserts **DIR** to gain control of the bus. The PHY will also de-assert **NXT**. At T5, the bus ownership has transferred back to the PHY and the PHY drives the requested register onto the data bus. At T6, the Link will read the data bus and the PHY will de-assert **DIR** returning control of the bus back to the Link. After the turn around cycle, the Link must drive a ULPI Idle command at T6.

FIGURE 6-6: ULPI EXTENDED REGISTER READ IN SYNCHRONOUS MODE

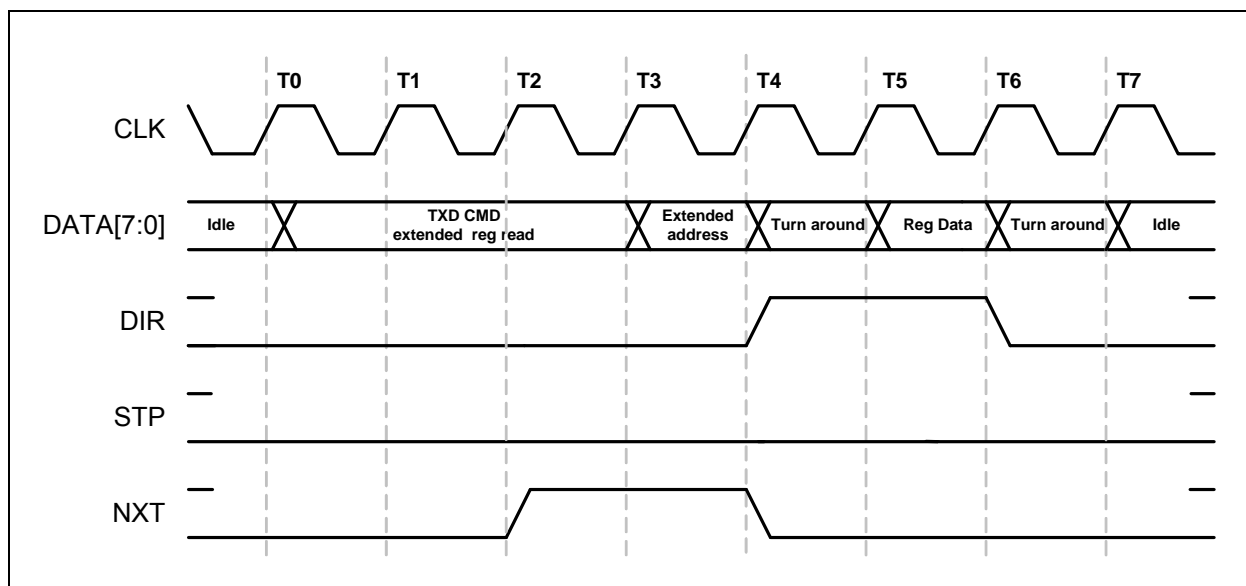

6.2.3 ULPI RXCMD

The ULPI Link needs information which was provided by the following pins in a UTMI implementation: `linestate[1:0]`, `rxactive`, `rxvalid` and `rxerror`. When implementing the OTG functions the **VBUS** and **ID** pin states must also be transferred to the Link.

ULPI defines a Receive Command Byte (RXCMD) that contains this information. The Encoding of the RXCMD byte is given in the Table 6-3.

Transfer of the RXCMD byte occurs in Synchronous Mode when the PHY has control of the bus. The ULPI Protocol Block shown in Figure 6-1 determines when to send an RXCMD. When a `linestate` change occurs, the RXCMD is sent immediately if the **DIR** output is low.

When a USB Receive is occurring, RXCMD's are sent whenever **NXT** = 0 and **DIR** = 1. During a USB Transmit, the RXCMD's are returned to the Link after **STP** is asserted.

To summarize a RXCMD transfer occurs:

- When **DIR** is low and a `linestate` change occurs.
- When `Vbus` and/or `ID` comparators change state.
- During a USB receive when **NXT** is low.
- After **STP** is asserted during a USB transmit command.
- After the USB3315 deasserts **DIR** and **STP** is low during start-up
- After the USB3315 exits Low Power Mode, Serial Modes, or CarKit Modes after detecting that the Link has asserted **STP**.

USB3315

TABLE 6-3: ULPI RX CMD ENCODING

DATA[7:0]	Name	Description and Value				
[1:0]	Linestate	UTMI Linestate Signals Note 3 :				
[3:2]	Encoded Vbus State	Encoded Vbus Voltage States				
		Value	Vbus Voltage	SessEnd	SessVld	VbusVld₂
		00	$V_{VBUS} < V_{SESS_END}$	1	0	0
		01	$V_{SESS_END} < V_{VBUS} < V_{SESS_VLD}$	0	0	0
		10	$V_{SESS_VLD} < V_{VBUS} < V_{VBUS_VLD}$	X	1	0
11	$V_{VBUS_VLD} < V_{VBUS}$	X	X	1		
[5:4]	Rx Event Encoding	Encoded UTMI Event Signals				
		Value	RxActive	RxError	HostDisconnect	
		00	0	0	0	
		01	1	0	0	
		11	1	1	0	
10	X	X	1			
[6]	State of ID pin	Set to the logic state of the ID pin. A logic low indicates an A device. A logic high indicates a B device.				
[7]	alt_int	Asserted when a non-USB interrupt occurs. This bit is set when an unmasked event occurs on any bit in the Carkit Interrupt Latch register. The Link must read the Carkit Interrupt Latch register to determine the source of the interrupt. Section 5.6.1.3 describes how a change on the ID pin can generate an interrupt. Section 6.5 describes how an interrupt can be generated when the <i>RidConversionDone</i> bit is set.				

Note 1: An 'X' is a do not care and can be either a logic 0 or 1.

Note 2: The value of VbusValid is defined in [Table 5-5](#).

Note 3: Linestate: These bits in the RXCMD byte reflect the current state of the Full-Speed single ended receivers. Linestate[0] directly reflects the current state of DP. Linestate[1] directly reflects the current state of DM. When DP=DM=0 this is called "Single Ended Zero" (SE0). When DP=DM=1, this is called "Single Ended One" (SE1).

6.2.4 USB3315 TRANSMITTER

The USB3315 ULPI transmitter fully supports HS, FS, and LS transmit operations. [Figure 6-1](#) shows the high speed, full speed, and low speed transmitter block controlled by ULPI Protocol Block. Encoding of the USB packet follows the bit-stuffing and NRZI outlined in the USB 2.0 specification. Many of these functions are re-used between the HS and FS/LS transmitters. When using the USB3315, [Table 5-1](#) should always be used as a guideline on how to configure for various modes of operation. The transmitter decodes the inputs of *XcvrSelect[1:0]*, *TermSelect*, *OpMode[1:0]*, *DpPulldown*, and *DmPulldown* to determine what operation is expected. Users must strictly adhere to the modes of operation given in [Table 5-1](#).

Several important functions for a device and host are designed into the transmitter blocks.

The USB3315 transmitter will transmit a 32-bit long high speed sync before every high speed packet. In full and low speed modes a 8-bit sync is transmitted.

When the device or host needs to chirp for high speed port negotiation, the *OpMode* = 10 setting will turn off the bit-stuffing and NRZI encoding in the transmitter. At the end of a chirp, the USB3315 *OpMode* register bits should be changed only after the RXCMD linestate encoding indicates that the transmitter has completed transmitting. Should the *OpMode* be switched to normal bit-stuffing and NRZI encoding before the transmit pipeline is empty, the remaining data in the pipeline may be transmitted in a bit-stuff encoding format.

Please refer to the ULPI specification for a detailed discussion of USB reset and HS chirp.

6.2.4.1 High Speed Long EOP

When operating as a Hi-Speed host, the USB3315 will automatically generate a 40 bit long End of Packet (EOP) after a SOF PID (A5h). The USB3315 determines when to send the 40-bit long EOP by decoding the ULPI TXD CMD bits [3:0] for the SOF. The 40-bit long EOP is only transmitted when the *DpPulldown* and *DmPulldown* bits in the [OTG Control](#) register are asserted. The Hi-Speed 40-bit long EOP is used to detect a disconnect in high speed mode.

In device mode, the USB3315 will not send a long EOP after a SOF PID.

6.2.4.2 Low Speed Keep-Alive

Low speed keep alive is supported by the USB3315. When in Low speed (10b), the USB3315 will send out two Low speed bit times of SE0 when a SOF PID is received.

6.2.4.3 UTMI+ Level 3

Pre-ambles are supported for UTMI+ Level 3 compatibility. When *XcvrSelect* is set to (11b) in host mode, (*DpPulldown* and *DmPulldown* both asserted) the USB3315 will pre-pend a full speed pre-ambles before the low speed packet. Full speed rise and fall times are used in this mode. The pre-ambles consist of the following: Full speed sync, the encoded pre-PID (C3h) and then full speed idle (DP=1 and DM = 0). A low speed packet follows with a sync, data and a LS EOP.

The USB3315 will only support UTMI+ Level 3 as a host. The USB3315 does not support UTMI+ Level 3 as a peripheral. A UTMI+ Level 3 peripheral is an upstream hub port. The USB3315 will not decode a pre-ambles packet intended for a LS device when the USB3315 is configured as the upstream port of a FS hub, *XcvrSelect* = 11b, *DpPulldown* = 0b, *DmPulldown* = 0b.

6.2.4.4 Host Resume K

Resume K generation is supported by the USB3315. When the USB3315 exits the suspended (Low Power Mode), the USB3315, when operating as a host, will transmit a K on DP/DM. The transmitters will end the K with SE0 for two Low Speed bit times. If the USB3315 was operating in high speed mode before the suspend, the host must change to high speed mode before the SE0 ends. SE0 is two low speed bit times which is about 1.2 μ s. For more details please see sections 7.1.77 and 7.9 of the USB Specification.

In device mode, the resume K will not append an SE0, but release the bus to the correct idle state, depending upon the operational mode as shown in [Table 5-1](#).

The ULPI specification includes a detailed discussion of the resume sequence and the order of operations required. To support Host start-up of less than 1 ms the USB3315 implements the ULPI *AutoResume* bit in the Interface Control register. The default *AutoResume* state is 0 and this bit should be enabled for Host applications.

6.2.4.5 No SYNC and EOP Generation (*OpMode* = 11)

UTMI+ defines *OpMode* = 11 where no sync and EOP generation occurs in Hi-Speed operation. This is an option to the ULPI specification and not implemented in the USB3315.

6.2.4.6 Typical USB Transmit with ULPI

[Figure 6-7](#) shows a typical USB transmit sequence. A transmit sequence starts by the Link sending a TXD CMD where **DATA[7:6]** = 01b, **DATA[5:4]** = 00b, and **DATA[3:0]** = PID. The TX CMD with the PID is followed by transmit data.

FIGURE 6-7: ULPI TRANSMIT IN SYNCHRONOUS MODE

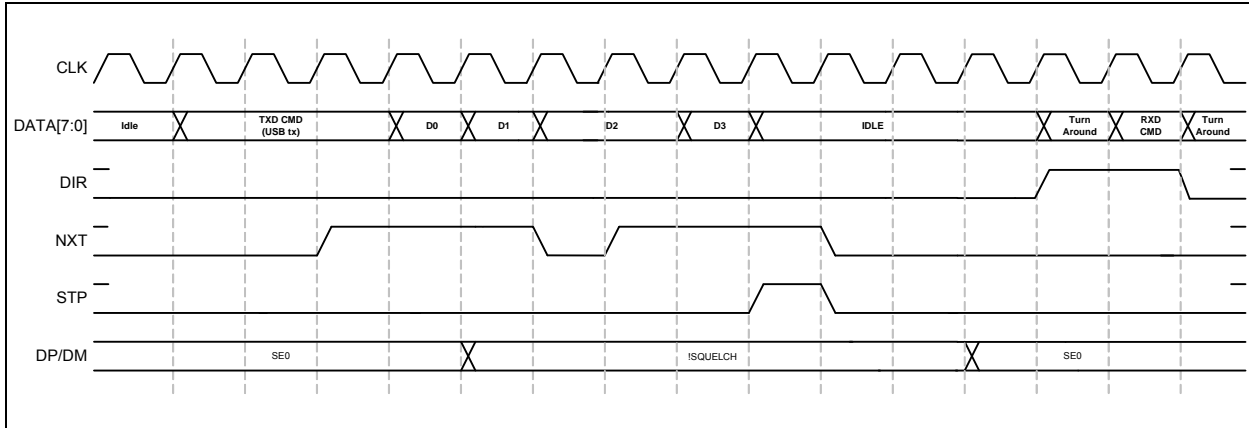

During transmit the PHY will use **NXT** to control the rate of data flow into the PHY. If the USB3315 pipeline is full or bit-stuffing causes the data pipeline to overflow **NXT** is de-asserted and the Link will hold the value on Data until **NXT** is asserted. The USB Transmit ends when the Link asserts **STP** while **NXT** is asserted.

Note: The Link cannot assert **STP** with **NXT** de-asserted since the USB3315 is expecting to fetch another byte from the Link.

After the USB3315 completes transmitting, the DP/DM lines return to idle and a RXCMD is returned to the Link so the inter-packet timers may be updated by linestate.

While operating in Full Speed or Low Speed, an End-of-Packet (EOP) is defined as SE0 for approximately two bit times, followed by J for one bit time. The transceiver drives a J state for one bit time following the SE0 to complete the EOP. The Link must wait for one bit time following line state indication of the SE0 to J transition to allow the transceiver to complete the one bit time J state. All bit times are relative to the speed of transmission.

In the case of Full Speed or Low Speed, after **STP** is asserted each FS/LS bit transition will generate a RXCMD since the bit times are relatively slow.

6.2.5 USB RECEIVER

The USB3315 ULPI receiver fully supports HS, FS, and LS transmit operations. In all three modes the receiver detects the start of packet and synchronizes to the incoming data packet. In the ULPI protocol, a received packet has the priority and will immediately follow register reads and RXCMD transfers. [Figure 6-8](#) shows a basic USB packet received by the USB3315 over the ULPI interface.

FIGURE 6-8: ULPI RECEIVE IN SYNCHRONOUS MODE

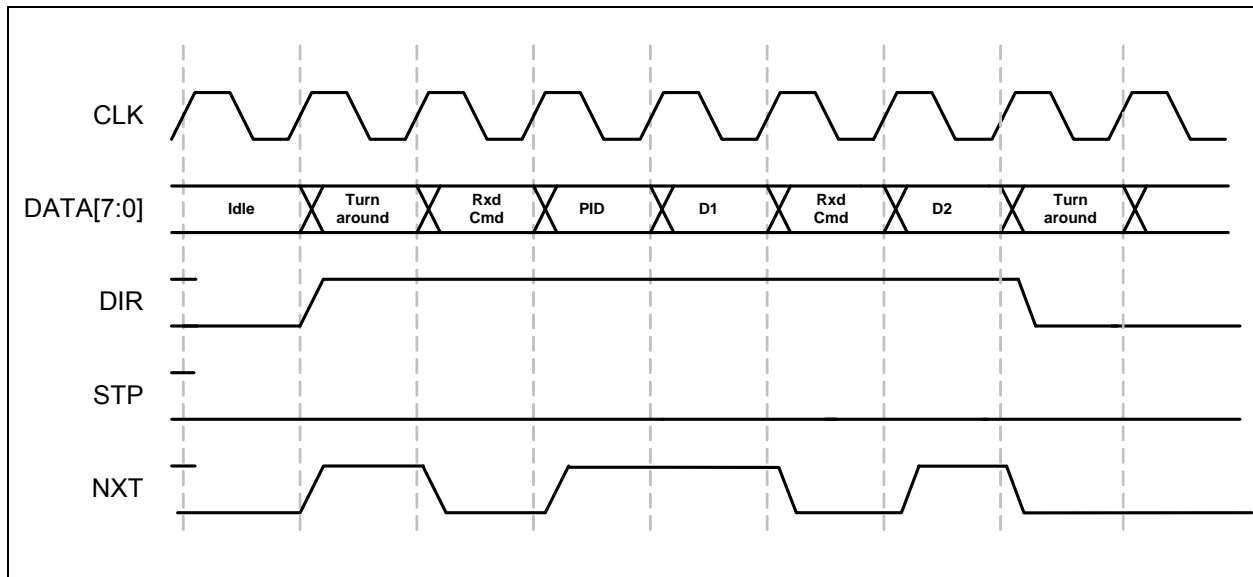

In [Figure 6-8](#) the PHY asserts **DIR** to take control of the data bus from the Link. The assertion of **DIR** and **NXT** in the same cycle contains additional information that Ractive has been asserted. When **NXT** is de-asserted and **DIR** is asserted, the RXCMD data is transferred to the Link. After the last byte of the USB receive packet is transferred to the PHY, the linestate will return to idle.

The ULPI full speed receiver operates according to the UTMI / ULPI specification. In the full speed case, the **NXT** signal will assert only when the Data bus has a valid received data byte. When **NXT** is low with **DIR** high, the RXCMD is driven on the data bus.

In full speed, the USB3315 will not issue a Ractive de-assertion in the RXCMD until the DP/DM linestate transitions to idle. This prevents the Link from violating the two full speed bit times minimum turn around time.

6.2.5.1 Disconnect Detection

A High Speed host must detect a disconnect by sampling the transmitter outputs during the long EOP transmitted during a SOF packet. The USB3315 only looks for a high speed disconnect during the long EOP where the period is long enough for the disconnect reflection to return to the host PHY. When a high speed disconnect occurs, the USB3315 will return a RXCMD and set the host disconnect bit in the [USB Interrupt Status](#) register.

When in FS or LS modes, the Link is expected to handle all disconnect detection.

6.2.6 LOW POWER MODE

Low Power Mode is a power down state to save current when the USB session is suspended. The Link controls when the PHY is placed into or out of Low Power Mode. In Low Power Mode all of the circuits are powered down except the interface pins, full speed receiver, VBUS comparators, and IdGnd comparator.

Before entering Low Power Mode, the USB3315 must be configured to set the desired state of the USB transceiver. The *XcvrSelect[1:0]*, *TermSelect* and *OpMode[1:0]* bits in the [Function Control](#) register, and the *DpPulldown* and *DmPull-down* bits in the [OTG Control](#) register control the configuration as shown in [Table 5-1](#). The **DP** and **DM** pins are configured to a high impedance state by configuring *OpMode[1:0]* = 01. Pull-down resistors with a value of approximately 2 MΩ are present on the **DP** and **DM** pins to avoid false linestate indications that could result if the pins were allowed to float.

6.2.6.1 Entering Low Power/Suspend Mode

To enter Low Power Mode, the Link will write a 0 or clear the *SuspendM* bit in the [Function Control](#) register. After this write is complete, the PHY will assert **DIR** high and after a minimum of five rising edges of **CLKOUT**, drive the clock low. After the clock is stopped, the PHY will enter a low power state to conserve current. Placing the PHY in Suspend Mode is not related to USB Suspend. To clarify this point, USB Suspend is initiated when a USB host stops data transmissions

USB3315

and enters Full-Speed mode with 15 kΩ pull-down resistors on **DP** and **DM**. The suspended device goes to Full-Speed mode with a pull-up on **DP**. Both the host and device remain in this state until one of them drives **DM** high (this is called a resume).

FIGURE 6-9: ENTERING LOW POWER MODE FROM SYNCHRONOUS MODE

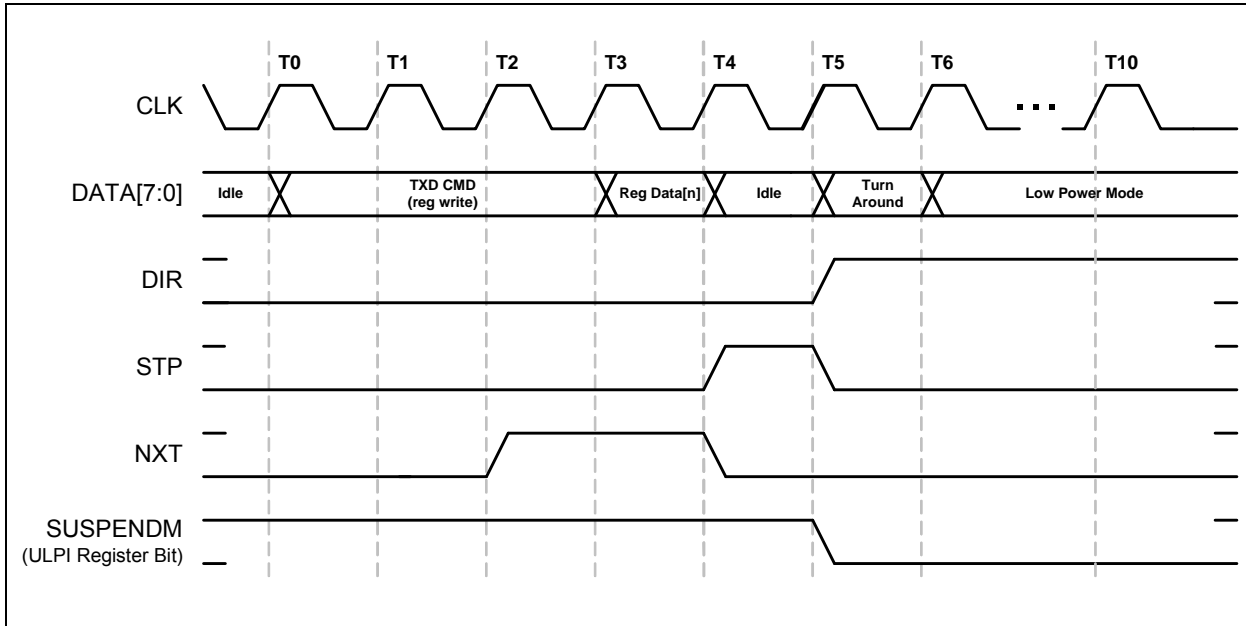

While in Low Power Mode, the Data interface is redefined so that the Link can monitor Linestate and the Vbus voltage. In Low Power Mode **DATA[3:0]** are redefined as shown in [Table 6-4](#). Linestate[1:0] is the combinational output of the Single-Ended Receivers. The “int” or interrupt signal indicates an unmasked interrupt has occurred. When an unmasked interrupt or linestate change has occurred, the Link is notified and can determine if it should wake-up the PHY.

TABLE 6-4: INTERFACE SIGNAL MAPPING DURING LOW POWER MODE

Signal	Maps to	Direction	Description
linestate[0]	DATA[0]	OUT	Combinatorial linestate[0] driven directly by FS analog receiver.
linestate[1]	DATA[1]	OUT	Combinatorial linestate[1] driven directly by FS analog receiver.
reserved	DATA[2]	OUT	Driven Low
int	DATA[3]	OUT	Active high interrupt indication. Must be asserted whenever any unmasked interrupt occurs.
reserved	DATA[7:4]	OUT	Driven Low

An unmasked interrupt can be caused by the following comparators changing state: VbusVld, SessVld, SessEnd, and IdGnd. If any of these signals change state during Low Power Mode and the bits are enabled in either the [USB Interrupt Enable Rising](#) or [USB Interrupt Enable Falling](#) registers, **DATA[3]** will assert. During Low Power Mode, the VbusVld and SessEnd comparators can have their interrupts masked to lower the suspend current as described in [Section 6.2.6.4](#).

While in Low Power Mode, the Data bus is driven asynchronously because all of the PHY clocks are stopped during Low Power Mode.

6.2.6.2 Exiting Low Power Mode

To exit Low Power Mode, the Link will assert **STP**. Upon the assertion of **STP**, the USB3315 will begin its start-up procedure. After the PHY start-up is complete, the PHY will start the clock on **CLKOUT** and de-assert **DIR**. After **DIR** has been de-asserted, the Link can de-assert **STP** when ready and start operating in Synchronous Mode. The PHY will automatically set the *SuspendM* bit to a 1 in the [Function Control](#) register.

FIGURE 6-10: EXITING LOW POWER MODE

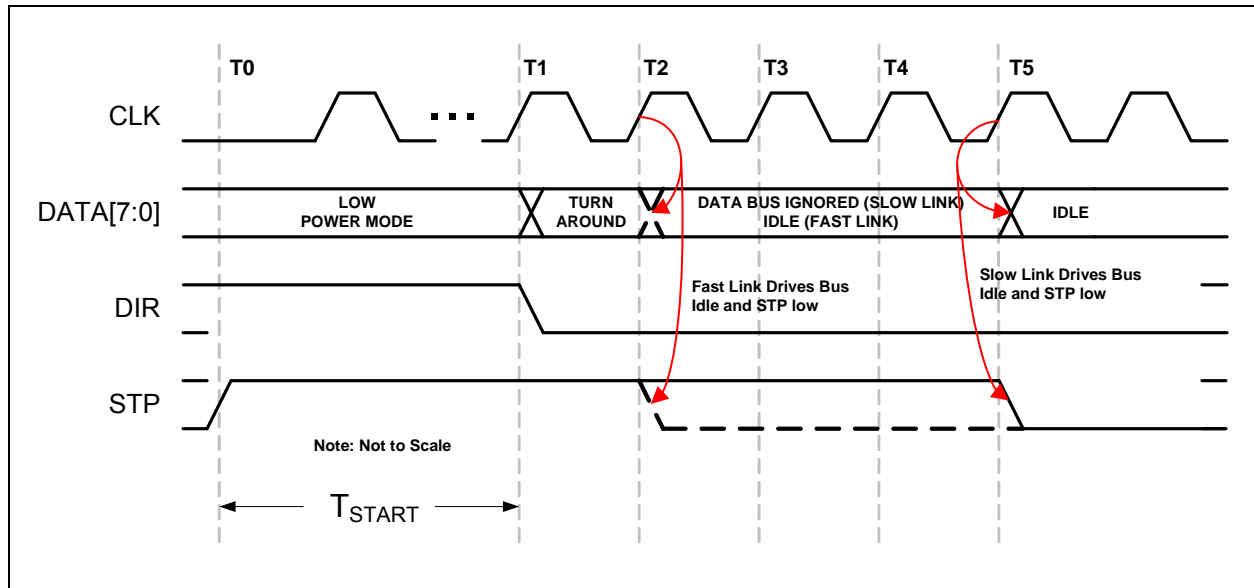

The value for T_{START} is given in [Table 4-2](#).

Should the Link de-assert **STP** before **DIR** is de-asserted, the USB3315 will detect this as a false resume request and return to Low Power Mode. This is detailed in section 3.9.4 of the ULPI 1.1 specification.

6.2.6.3 Interface Protection

ULPI protocol assumes that both the Link and PHY will keep the ULPI data bus driven by either the Link when **DIR** is low or the PHY when **DIR** is high. The only exception is when **DIR** has changed state and a turn around cycle occurs for 1 clock period.

In the design of a USB system, there can be cases where the Link may not be driving the ULPI bus to a known state while **DIR** is low. Two examples where this can happen is because of a slow Link start-up or a hardware reset.

Start up Protection

Upon start-up, when the PHY de-asserts **DIR**, the Link must be ready to receive commands and drive Idle on the data bus. If the Link is not ready to receive commands or drive Idle, it must assert **STP** before **DIR** is de-asserted. The Link can then de-assert **STP** when it has completed its start-up. If the Link doesn't assert **STP** before it can receive commands, the **PHY** may interpret the data bus state as a TX CMD and transmit invalid data onto the **USB** bus, or make invalid register writes.

When the USB3315 sends a RXCMD the Link is required to drive the data bus back to idle at the end of the turn around cycle. If the Link does not drive the databus to idle the USB3315 may take the information on the data bus as a TXCMD and transmit data on **DP** and **DM** until the Link asserts stop. If the **ID** pin is floated the last RXCMD from the USB3315 will remain on the bus after **DIR** is de-asserted and the USB3315 will take this in as a TXCMD.

A Link should be designed to have the default POR state of the **STP** output high and the data bus tri-stated. The USB3315 has weak pull-downs on the data bus to prevent these inputs from floating when not driven. These resistors are only used to prevent the ULPI interface from floating during events when the link ULPI pins may be tri-stated. The strength of the pull down resistors can be found in [Table 4-4](#). The pull downs are not strong enough to pull the data bus low after a ULPI RXCMD, the Link must drive the data bus to idle after **DIR** is de-asserted.

USB3315

In some cases, a Link may be software configured and not have control of its **STP** pin until after the PHY has started. In this case, the USB3315 has an internal pull-up on the **STP** input pad which will pull **STP** high while the Link's **STP** output is tri-stated. The **STP** pull-up resistor is enabled on POR and can be disabled by setting the *InterfaceProtectDisable* bit 7 of the Interface Control register.

The **STP** pull-up resistor will pull-up the Link's **STP** input high until the Link configures and drives **STP** high. After the Link completes its start-up, **STP** can be synchronously driven low.

A Link design which drives **STP** high during POR can disable the pull-up resistor on **STP** by setting *InterfaceProtectDisable* bit to 1. A motivation for this is to reduce the suspend current. In Low Power Mode, **STP** is held low, which would draw current through the pull-up resistor on **STP**.

Warm Reset

Designers should also consider the case of a warm restart of a Link with a PHY in Low Power Mode. After the PHY enters Low Power Mode, **DIR** is asserted and the clock is stopped. The USB3315 looks for **STP** to be asserted to restart the clock and then resume normal synchronous operation.

Should the USB3315 be suspended in Low Power Mode, and the Link receives a hardware reset, the PHY must be able to recover from Low Power Mode and start its clock. If the Link asserts **STP** on reset, the PHY will exit Low Power Mode and start its clock.

If the Link does not assert **STP** on reset, the interface protection pull-up can be used. When the Link is reset, its **STP** output will tri-state and the pull-up resistor will pull **STP** high, signaling the PHY to restart its clock.

6.2.6.4 Minimizing Current in Low Power Mode

In order to minimize the suspend current in Low Power Mode, the OTG comparators can be disabled to reduce suspend current. In Low Power Mode, the VbusVId and SessEnd comparators are not needed and can be disabled by clearing the associated bits in both the [USB Interrupt Enable Rising](#) and [USB Interrupt Enable Falling](#) registers. By disabling the interrupt in BOTH the rise and fall registers, the SessEnd and VbusVId comparators are turned off. The *IdFloatRise* and *IdFloatFall* bits in [Carkit Interrupt Enable](#) register should also be disabled if they were set. When exiting Low Power Mode, the Link should immediately re-enable the VbusVId and SessEnd comparators if host or OTG functionality is required.

In addition to disabling the OTG comparators in Low Power Mode, the Link may choose to disable the Interface Protect Circuit. By setting the *InterfaceProtectDisable* bit high in the [Interface Control](#) register, the Link can disable the pull-up resistor on **STP**. When **RESETB** is low the Interface Protect Circuit will be disabled.

6.3 Full Speed/Low Speed Serial Modes

The USB3315 includes two serial modes to support legacy Links which use either the 3-pin or 6-pin serial format. To enter either serial mode, the Link will need to write a 1 to the *6-pin FsLsSerialMode* or the *3-pin FsLsSerialMode* bits in the Interface control register. Serial Mode may be used to conserve power when attached to a device that is not capable of operating in Hi-Speed.

The serial modes are entered in the same manner as the entry into Low Power Mode. The Link writes the Interface Control register bit for the specific serial mode. The USB3315 will assert **DIR** and shut off the clock after at least five clock cycles. Then the data bus goes to the format of the serial mode selected. Before entering either serial mode, the Link must set the ULPI transceiver to the appropriate mode as defined in [Table 5-1](#).

By default, the PHY will shut off the 60 MHz clock to conserve power. Should the Link need the 60 MHz clock to continue during the serial mode of operation, the *ClockSuspendM* bit[3] of the [Interface Control](#) Register should be set before entering a serial mode. If set, the 60 MHz clock will be present during serial modes.

In serial mode, interrupts are possible from unmasked sources. The state of each interrupt source is sampled prior to the assertion of **DIR** and this is compared against the asynchronous level from interrupt source.

Exiting the serial modes is the same as exiting Low Power Mode. The Link must assert **STP** to signal the PHY to exit serial mode. When the PHY can accept a command, **DIR** is de-asserted and the PHY will wait until the Link de-asserts **STP** to resume synchronous ULPI operation. The **RESETB** pin can also be pulsed low to reset the USB3315 and return it to Synchronous Mode.

6.3.1 3-PIN FS/LS SERIAL MODE

Three pin serial mode utilizes the data bus pins for the serial functions shown in [Table 6-5](#).

TABLE 6-5: PIN DEFINITIONS IN 3-PIN SERIAL MODE

Signal	Connected to	Direction	Description
tx_enable	DATA[0]	IN	Active High transmit enable.
data	DATA[1]	I/O	TX differential data on DP/DM when tx_enable is high. RX differential data from DP/DM when tx_enable is low.
SE0	DATA[2]	I/O	TX SE0 on DP/DM when tx_enable is high. RX SE0_b from DP/DM when tx_enable is low.
interrupt	DATA[3]	OUT	Asserted when any unmasked interrupt occurs. Active high.
Reserved	DATA[7:4]	OUT	Driven Low.

6.3.2 6-PIN FS/LS SERIAL MODE

Six pin serial mode utilizes the data bus pins for the serial functions shown in [Table 6-6](#).

TABLE 6-6: PIN DEFINITIONS IN 6-PIN SERIAL MODE

Signal	Connected to	Direction	Description
tx_enable	DATA[0]	IN	Active High transmit enable.
tx_data	DATA[1]	IN	Tx differential data on DP/DM when tx_enable is high.
tx_se0	DATA[2]	IN	Tx SE0 on DP/DM when tx_enable is high.
interrupt	DATA[3]	OUT	Asserted when any unmasked interrupt occurs. Active high.
rx_dp	DATA[4]	OUT	Single ended receive data on DP.
rx_dm	DATA[5]	OUT	Single ended receive data on DM.
rx_rcv	DATA[6]	OUT	Differential receive data from DP and DM.
Reserved	DATA[7]	OUT	Driven Low.

6.4 Carkit Mode

The USB3315 includes Carkit Mode to support a USB UART Mode.

60 MHz clock is stopped to conserve power by default. The Link may configure the 60 MHz clock to continue by setting the *ClockSuspendM* bit of [Interface Control](#) before entering Carkit Mode. If set, the 60 MHz clock will continue during the Carkit Mode of operation.

In Carkit Mode, interrupts are possible from unmasked sources. The state of each interrupt source is sampled prior to the assertion of **DIR** and this is compared against the asynchronous level from interrupt source. In Carkit Mode, the Linestate signals are not available per the ULPI specification.

Exiting Carkit Mode is the same as exiting Low Power Mode as described in [Section 6.2.6.2](#). The Link must assert **STP** to signal the PHY to exit serial mode. When the PHY can accept a command, **DIR** is de-asserted and the PHY will wait until the Link de-asserts **STP** to resume synchronous ULPI operation. The **RESETB** pin can also be pulsed low to reset the USB3315 and return it to Synchronous Mode.

USB3315

6.4.1 USB UART MODE

The USB3315 can be placed into UART Mode by first setting the *TxdEn* and *RxdEn* bits in the [Carkit Control](#) register. Then the Link can set the *CarkitMode* bit in the [Interface Control](#) register. The *TxdEn* and *RxdEn* bits must be written before the *CarkitMode* bit. After the *CarkitMode* bit is set, the ULPI interface will become redefined as described in [Table 6-7](#), and the USB3315 will transmit data through the **DATA[0]** to **DM** of the USB connector and receive data on **DP** and pass the information the Link on **DATA[1]**.

When entering UART mode, the regulator output will automatically switch to the value configured by the *UART RegOutput bits* in the [USB IO & Power Management](#) register and a 125 kΩ R_{CD} pull-up will be applied internally to **DP** and **DM**. This will hold the UART in its default operating state.

While in UART mode, the transmit edge rates can be set to either the Full Speed USB or Low Speed USB edge rates by using the *XcvrSelect[1:0]* bits in the [Function Control](#) register.

TABLE 6-7: PIN DEFINITIONS IN CARKIT MODE

Signal	Connected to	Direction	Description
txd	DATA[0]	IN	UART TXD signal that is routed to the DM pin if the <i>TxdEn</i> is set in the Carkit Control register.
rxid	DATA[1]	OUT	UART RXD signal that is routed to the DP pin if the <i>RxdEn</i> bit is set in the Carkit Control register.
Reserved	DATA[2]	OUT	Driven Low.
int	DATA[3]	OUT	Asserted when any unmasked interrupt occurs. Active high.
Reserved	DATA[4:7]	OUT	Driven Low.

6.5 RID Converter Operation

The RID converter is designed to read the value of the ID resistance to ground and report back its value through the ULPI interface.

When a resistor to ground is applied to the **ID** pin the state of the *IdGnd* comparator will change from a 1 to a 0 as described in [Section 5.6.1](#). If the USB3315 is in ULPI mode, an RXCMD will be generated with bit 6 low. If the USB3315 is in Low Power Mode (or one of the other non-ULPI modes), the **DATA[3]** interrupt signal will go high.

After the USB3315 has detected the change of state on the **ID** pin, the RID converter can be used to determine the value of ID resistance. To start a ID resistance measurement, the *RidConversionStart* bit is set in the [Vendor Rid Conversion](#) register.

The Link can use one of two methods to determine when the RID Conversion is complete. One method is polling the *RidConversionStart* bit as described in [Section 7.1.4.3](#). The preferred method is to set the *RidIntEn* bit in the [Vendor Rid Conversion](#) register. When *RidIntEn* is set, an RXCMD will be generated after the RID conversion is complete. As described in [Table 6-3](#), the *alt_int* bit of the RXCMD will be set.

After the RID Conversion is complete, the Link can read *RidValue* from the [Vendor Rid Conversion](#) register.

6.6 Headset Audio Mode

This mode is designed to allow a user to view the status of several signals while using an analog audio headset with a USB connector. This feature, exclusive to Microchip, is provided as an alternate mode to the CarKit Mode defined in [Section 6.4](#). In the CarKit Mode, the Link is unable to view the source of the interrupt on **ID**, except by returning to synchronous mode to read the ULPI registers. This forces the audio switches to be deactivated, and may glitch the audio signals. In addition, the Link cannot change the resistance on the **ID** pin without starting up the PHY to access the ULPI registers.

The Headset Audio Mode is entered by writing to the [Headset Audio Mode](#) register, and allows the Link access to the state of the **VBUS** and **ID** pins during audio without glitching the audio connection. The Headset Audio mode also enables the Link to change the resistance on the **ID** pin and to change the audio headset attached from mono to stereo.

The ULPI interface is redefined as shown in [Table 6-8](#) when Headset Audio Mode is entered.

TABLE 6-8: PIN DEFINITIONS IN HEADSET AUDIO MODE

Signal	Connected to	Direction	Description
SessVId	DATA[0]	OUT	Output of SessVId comparator
VbusVId	DATA[1]	OUT	Output of VbusVId Comparator (interrupt must be enabled)
IdGndDrv	DATA[2]	IN	Drives ID pin to ground when asserted 0b: Not connected 1b: Connects ID to ground.
	DATA[3]	OUT	Driven low
IdGround	DATA[4]	OUT	Asserted when the ID pin is grounded. 0b: ID pin is grounded 1b: ID pin is floating
IdFloat	DATA[5]	OUT	Asserted when the ID pin is floating. <i>IdPullup</i> or <i>IdPullup330</i> must be enabled as shown below.
IdPullup330	DATA[6]	IN	When enabled a 330 kΩ pull-up is applied to the ID pin. 0b: Disables the pull-up resistor 1b: Enables the pull-up resistor
IdPullup	DATA[7]	IN	Connects the 100 kΩ pull-up resistor from the ID pin to VDD3.3 0b: Disables the pull-up resistor 1b: Enables the pull-up resistor

Exiting Headset Audio Mode is the same as exiting Low Power Mode as described in [Section 6.2.6.2](#). The Link must assert **STP** to signal the PHY to exit. When the PHY can accept a command, **DIR** is de-asserted and the PHY will wait until the Link de-asserts **STP** to resume synchronous ULPI operation. The **RESETB** pin can also be pulsed low to reset the USB3315 and return it to Synchronous Mode.

USB3315

7.0 ULPI REGISTER MAP

7.1 ULPI Register Array

The USB3315 PHY implements all of the ULPI registers detailed in the ULPI revision 1.1 specification. The complete USB3315 ULPI register set is shown in [Table 7-1](#). All registers are 8 bits. This table also includes the default states of the register upon POR, as described in [Section 5.5.2](#). The RESET bit in the [Function Control](#) Register does not reset the bits of the ULPI register array. The Link should not read or write to any registers not listed in this table.

The USB3315 supports extended register access. The immediate register set (00-3Fh) can be accessed through either an immediate address or an extended register address..

TABLE 7-1: ULPI REGISTER MAP

Register Name	Default State	Address (6bit)			
		Read	Write	Set	Clear
Vendor ID Low	24h	00h	-	-	-
Vendor ID High	04h	01h	-	-	-
Product ID Low	06h	02h	-	-	-
Product ID High	00h	03h	-	-	-
Function Control	41h	04-06h	04h	05h	06h
Interface Control	00h	07-09h	07h	08h	09h
OTG Control	06h	0A-0Ch	0Ah	0Bh	0Ch
USB Interrupt Enable Rising	1Fh	0D-0Fh	0Dh	0Eh	0Fh
USB Interrupt Enable Falling	1Fh	10-12h	10h	11h	12h
USB Interrupt Status	00h	13h	-	-	-
USB Interrupt Latch	00h	14h	-	-	-
Debug	00h	15h	-	-	-
Scratch Register	00h	16-18h	16h	17h	18h
Carkit Control	00h	19-1Bh	19h	1Ah	1Bh
Reserved	00h	1Ch			
Carkit Interrupt Enable	00h	1D-1Fh	1Dh	1Eh	1Fh
Carkit Interrupt Status	00h	20h	-	-	-
Carkit Interrupt Latch	00h	21h	-	-	-
Reserved	00h	22-30h			
HS TX Boost	00h	31h	31h	-	-
Reserved	00h	32h			
Headset Audio Mode	00h	33h	33h	-	-
Reserved	00h	34-35h			
Vendor Rid Conversion	00h	36-38h	36h	37h	38h

TABLE 7-1: ULPI REGISTER MAP (CONTINUED)

Register Name	Default State	Address (6bit)			
		Read	Write	Set	Clear
USB IO & Power Management	04h	39-3Bh	39h	3Ah	3Bh
Reserved	00h	3C-3Fh			

7.1.1 ULPI REGISTER SET

The following registers are used for the ULPI interface.

7.1.1.1 Vendor ID Low

Address = 00h (read only)

Field name	Bit	Access	Default	Description
<i>Vendor ID Low</i>	7:0	rd	24h	Microchip Vendor ID

7.1.1.2 Vendor ID High

Address = 01h (read only)

Field name	Bit	Access	Default	Description
<i>Vendor ID High</i>	7:0	rd	04h	Microchip Vendor ID

7.1.1.3 Product ID Low

Address = 02h (read only)

Field name	Bit	Access	Default	Description
<i>Product ID Low</i>	7:0	rd	06h	Microchip Product ID

7.1.1.4 Product ID High

Address = 03h (read only)

Field name	Bit	Access	Default	Description
<i>Product ID High</i>	7:0	rd	00h	Microchip Product ID

USB3315

7.1.1.5 Function Control

Address = 04-06h (read), 04h (write), 05h (set), 06h (clear)

Field name	Bit	Access	Default	Description
<i>XcvrSelect[1:0]</i>	1:0	rd/w/s/c	01b	Selects the required transceiver speed. 00b: Enables HS transceiver 01b: Enables FS transceiver 10b: Enables LS transceiver 11b: Enables FS transceiver for LS packets (FS preamble automatically pre-pended)
<i>TermSelect</i>	2	rd/w/s/c	0b	Controls the DP and DM termination depending on <i>XcvrSelect</i> , <i>OpMode</i> , <i>DpPulldown</i> , and <i>DmPulldown</i> . The DP and DM termination is detailed in Table 5-1 .
<i>OpMode</i>	4:3	rd/w/s/c	00b	Selects the required bit encoding style during transmit. 00b: Normal Operation 01b: Non-Driving 10b: Disable bit-stuff and NRZI encoding 11b: Reserved
<i>Reset</i>	5	rd/w/s/c	0b	Active high transceiver reset. This reset does not reset the ULPI interface or register set. Automatically clears after reset is complete.
<i>SuspendM</i>	6	rd/w/s/c	1b	Active low PHY suspend. When cleared the PHY will enter Low Power Mode as detailed in Section 6.2.6 . Automatically set when exiting Low Power Mode.
<i>Reserved</i>	7	rd	0b	Read only, 0.

7.1.1.6 Interface Control

Address = 07-09h (read), 07h (write), 08h (set), 09h (clear)

Field name	Bit	Access	Default	Description
<i>6-pin FsLsSerialMode</i>	0	rd/w/s/c	0b	When asserted the ULPI interface is redefined to the 6-pin Serial Mode. The PHY will automatically clear this bit when exiting serial mode.
<i>3-pin FsLsSerialMode</i>	1	rd/w/s/c	0b	When asserted the ULPI interface is redefined to the 3-pin Serial Mode. The PHY will automatically clear this bit when exiting serial mode.
<i>CarkitMode</i>	2	rd/w/s/c	0b	When asserted the ULPI interface is redefined to the Carkit interface. The PHY will automatically clear this bit when exiting Carkit mode.
<i>ClockSuspendM</i>	3	rd/w/s/c	0b	Enables Link to turn on 60 MHz CLKOUT in serial or Carkit mode. 0b: Disable clock in serial or Carkit mode. 1b: Enable clock in serial or Carkit mode.
<i>AutoResume</i>	4	rd/w/s/c	0b	Only applicable in Host mode. Enables the PHY to automatically transmit resume signaling. This function is detailed in Section 6.2.4.4 .

Field name	Bit	Access	Default	Description
<i>IndicatorComplement</i>	5	rd/w/s/c	0b	Inverts the EXTVBUS signal. This function is detailed in Section 5.6.2 . Note: The EXTVBUS input is always high on the USB3315.
<i>IndicatorPassThru</i>	6	rd/w/s/c	0b	Disables AND'ing the internal VBUS comparator with the EXTVBUS input when asserted. This function is detailed in Section 5.6.2 . Note: The EXTVBUS input is always high on the USB3315.
<i>InterfaceProtectDisable</i>	7	rd/w/s/c	0b	Used to disable the integrated STP pull-up resistor used for interface protection. This function is detailed in Section 6.2.6.3 .

7.1.1.7 OTG Control

Address = 0A-0Ch (read), 0Ah (write), 0Bh (set), 0Ch (clear)

Field name	Bit	Access	Default	Description
<i>IdPullup</i>	0	rd/w/s/c	0b	Connects a 100 kΩ pull-up resistor from the ID pin to VDD33 0b: Disables the pull-up resistor 1b: Enables the pull-up resistor
<i>DpPulldown</i>	1	rd/w/s/c	1b	Enables the 15 kΩ pull-down resistor on DP . 0b: Pull-down resistor not connected 1b: Pull-down resistor connected
<i>DmPulldown</i>	2	rd/w/s/c	1b	Enables the 15 kΩ pull-down resistor on DM . 0b: Pull-down resistor not connected 1b: Pull-down resistor connected
<i>DischrgVbus</i>	3	rd/w/s/c	0b	This bit is only used during SRP. Connects a resistor from VBUS to ground to discharge VBUS . 0b: disconnect resistor from VBUS to ground 1b: connect resistor from VBUS to ground
<i>ChrgVbus</i>	4	rd/w/s/c	0b	This bit is only used during SRP. Connects a resistor from VBUS to VDD33 to charge VBUS above the SessValid threshold. 0b: disconnect resistor from VBUS to VDD33 1b: connect resistor from VBUS to VDD33
<i>DrvVbus</i>	5	rd/w/s/c	0b	Used to enable external 5 V supply to drive 5 V on VBUS. This signal is OR'ed with <i>DrvVbusExternal</i> . 0b: do not drive Vbus, CPEN driven low. 1b: drive Vbus, CPEN driven high.
<i>DrvVbusExternal</i>	6	rd/w/s/c	0b	Used to enable external 5 V supply to drive 5 V on Vbus. This signal is OR'ed with <i>DrvVbus</i> . 0b: do not drive Vbus, CPEN driven low. 1b: drive Vbus, CPEN driven high

USB3315

Field name	Bit	Access	Default	Description
<i>UseExternalVbus Indicator</i>	7	rd/w/s/c	0b	Tells the PHY to use an external VBUS over-current or voltage indicator. This function is detailed in Section 5.6.2 . 0b: Use the internal VbusValid comparator 1b: Use the EXTVBUS input as for VbusValid signal. Note: The EXTVBUS input is always high on the USB3315.

7.1.1.8 USB Interrupt Enable Rising

Address = 0D-0Fh (read), 0Dh (write), 0Eh (set), 0Fh (clear)

Field name	Bit	Access	Default	Description
<i>HostDisconnect Rise</i>	0	rd/w/s/c	1b	Generate an interrupt event notification when Host-disconnect changes from low to high. Applicable only in host mode.
<i>VbusValid Rise</i>	1	rd/w/s/c	1b	Generate an interrupt event notification when Vbusvalid changes from low to high.
<i>SessValid Rise</i>	2	rd/w/s/c	1b	Generate an interrupt event notification when SessValid changes from low to high.
<i>SessEnd Rise</i>	3	rd/w/s/c	1b	Generate an interrupt event notification when SessEnd changes from low to high.
<i>IdGnd Rise</i>	4	rd/w/s/c	1b	Generate an interrupt event notification when IdGnd changes from low to high.
<i>Reserved</i>	7:5	rd	0h	Read only, 0.

7.1.1.9 USB Interrupt Enable Falling

Address = 10-12h (read), 10h (write), 11h (set), 12h (clear)

Field name	Bit	Access	Default	Description
<i>HostDisconnect Fall</i>	0	rd/w/s/c	1b	Generate an interrupt event notification when Host-disconnect changes from high to low. Applicable only in host mode.
<i>VbusValid Fall</i>	1	rd/w/s/c	1b	Generate an interrupt event notification when Vbusvalid changes from high to low.
<i>SessValid Fall</i>	2	rd/w/s/c	1b	Generate an interrupt event notification when SessValid changes from high to low.
<i>SessEnd Fall</i>	3	rd/w/s/c	1b	Generate an interrupt event notification when SessEnd changes from high to low.
<i>IdGnd Fall</i>	4	rd/w/s/c	1b	Generate an interrupt event notification when IdGnd changes from high to low.
<i>Reserved</i>	7:5	rd	0h	Read only, 0.

7.1.1.10 USB Interrupt Status

Address = 13h (read only)

Field name	Bit	Access	Default	Description
<i>HostDisconnect</i>	0		0b Note 1	Current value of the UTMI+ Hi-Speed Hostdisconnect output. Applicable only in host mode.
<i>VbusValid</i>	1		0b Note 1	Current value of the UTMI+ Vbusvalid output.
<i>SessValid</i>	2		0b Note 1	Current value of the UTMI+ SessValid output.
<i>SessEnd</i>	3		0b Note 1	Current value of the UTMI+ SessEnd output.
<i>IdGnd</i>	4		0b Note 1	Current value of the UTMI+ IdGnd output.
<i>Reserved</i>	7:5		0h	Read only, 0.

Note 1: The default conditions will match the current status of the comparators. The values shown are for an unattached OTG device.

7.1.1.11 USB Interrupt Latch

Address = 14h (read only with auto clear)

Field name	Bit	Access	Default	Description
<i>HostDisconnect Latch</i>	0	Note 2	0b	Set to 1b by the PHY when an unmasked event occurs on Hostdisconnect. Cleared when this register is read. Applicable only in host mode.
<i>VbusValid Latch</i>	1		0b	Set to 1b by the PHY when an unmasked event occurs on VbusValid. Cleared when this register is read.
<i>SessValid Latch</i>	2		0b	Set to 1b by the PHY when an unmasked event occurs on SessValid. Cleared when this register is read.
<i>SessEnd Latch</i>	3		0b	Set to 1b by the PHY when an unmasked event occurs on SessEnd. Cleared when this register is read.
<i>IdGnd Latch</i>	4		0b	Set to 1b by the PHY when an unmasked event occurs on IdGnd. Cleared when this register is read.
<i>Reserved</i>	7:5		0h	Read only, 0.

Note 2: Read Only with auto clear.

USB3315

7.1.1.12 Debug

Address = 15h (read only)

Field name	Bit	Access	Default	Description
<i>Linestate0</i>	0	rd	0b	Contains the current value of Linestate[0].
<i>Linestate1</i>	1	rd	0b	Contains the current value of Linestate[1].
<i>Reserved</i>	7:2	rd	000000b	Read only, 0.

7.1.1.13 Scratch Register

Address = 16-18h (read), 16h (write), 17h (set), 18h (clear)

Field name	Bit	Access	Default	Description
<i>Scratch</i>	7:0	rd/w/s/c	00h	Empty register byte for testing purposes. Software can read, write, set, and clear this register and the PHY functionality will not be affected.

7.1.2 CARKIT CONTROL REGISTERS

The following registers are used to set-up and enable the USB UART functions.

7.1.2.1 Carkit Control

Address = 19-1Bh (read), 19h (write), 1Ah (set), 1Bh (clear)

This register is used to program the USB3315 into and out of the Carkit modes. When entering the Carkit UART mode the Link must first set the desired *TxdEn* and the *RxdEn* bits and then transition to Carkit Mode by setting the *CarkitMode* bit in the Interface Control Register. When *RxdEn* is not set then the DATA[1] pin is held to a logic high.

Field name	Bit	Access	Default	Description
<i>CarkitPwr</i>	0	rd	0b	Read only, 0.
<i>IdGndDrv</i>	1	rd/w/s/c	0b	Drives ID pin to ground
<i>TxdEn</i>	2	rd/w/s/c	0b	Connects UART TXD (DATA[0]) to DM
<i>RxdEn</i>	3	rd/w/s/c	0b	Connects UART RXD (DATA[1]) to DP
<i>Reserved</i>	4-7	rd	0b	Read only, 0.

7.1.2.2 Carkit Interrupt Enable

Address = 1D-1Fh (read), 1Dh (write), 1Eh (set), 1Fh (clear)

Field name	Bit	Access	Default	Description
<i>IdFloatRise</i>	0	rd/w/s/c	0b	When enabled an interrupt will be generated on the <i>alt_int</i> of the RXCMD byte when the ID pin transitions from non-floating to floating. The <i>IdPullup</i> bit in the OTG Control register should be set.
<i>IdFloatFall</i>	1	rd/w/s/c	0b	When enabled an interrupt will be generated on the <i>alt_int</i> of the RXCMD byte when the ID pin transitions from floating to non-floating. The <i>IdPullup</i> bit in the OTG Control register should be set.
<i>CarIntDet</i>	2	rd	0b	Not Implemented. Reads as 0b.
<i>CarDpRise</i>	3	rd	0b	Not Implemented. Reads as 0b.
<i>CarDpFall</i>	4	rd	0b	Not Implemented. Reads as 0b.
<i>RidIntEn</i>	5	rd/w/s/c	0b	When enabled an interrupt will be generated on the <i>alt_int</i> of the RXCMD byte when <i>RidConversionDone</i> bit is asserted. Note: This register bit is OR'ed with the <i>RidIntEn</i> bit of the Vendor Rid Conversion register described in Section 7.1.4.3 .
<i>Reserved</i>	7:6	rd	0b	Read only, 0.

7.1.2.3 Carkit Interrupt Status

Address = 20h (read only)

Field name	Bit	Access	Default	Description
<i>IdFloat</i>	0	rd	0b	Asserted when the ID pin is floating. <i>IdPullup</i> must be enabled.
<i>CarIntDet</i>	1	rd	0b	Not Implemented. Reads as 0b.
<i>CarDp</i>	2	rd	0b	Not Implemented. Reads as 0b.
<i>RidValue</i>	5:3	rd	000b	Conversion value of Rid resistor 000: 0 Ω 001: 75 Ω 010: 102 kΩ 011: 200 kΩ 100: 440 kΩ 101: ID floating 111: Error Note: <i>RidValue</i> can also be read from the Vendor Rid Conversion register described in Section 7.1.4.3 .

USB3315

Field name	Bit	Access	Default	Description
<i>RidConversionDone</i>	6	rd	0b	Automatically asserted by the USB3315 when the Rid Conversion is finished. The conversion will take 282 μ s. This bit will auto clear when the <i>RidValue</i> is read from the Rid Conversion Register. Reading the <i>RidValue</i> from the CarKit interrupt Status register will not clear either <i>RidConversionDone</i> status bit. Note: <i>RidConversionDone</i> can also be read from the Vendor Rid Conversion register described in Section 7.1.4.3 .
<i>Reserved</i>	7	rd	0b	Read only, 0.

7.1.2.4 CarKit Interrupt Latch

Address = 21h (read only with auto-clear)

Field name	Bit	Access	Default	Description
<i>IdFloat Latch</i>	0	rd*	0b	Asserted if the state of the ID pin changes from non-floating to floating while the <i>IdFloatRise</i> bit is enabled or if the state of the ID pin changes from floating to non-floating while the <i>IdFloatFall</i> bit is enabled.
<i>CarIntDet Latch</i>	1	rd	0b	Not Implemented. Reads as 0b.
<i>CarDp Latch</i>	2	rd	0b	Not Implemented. Reads as 0b.
<i>RidConversionLatch</i>	3	rd*	0b	If <i>RidIntEn</i> is set and the state of the <i>RidConversionDone</i> bit changes from a 0 to 1 this bit will be asserted.
<i>Reserved</i>		rd	00000b	Read only, 0.

Note: rd*: Read Only with auto clear.

7.1.3 EXTENDED REGISTER ACCESS

The USB3315 supports extended register access. The immediate register set (00-3Fh) can be accessed through either a immediate address or an extended register address.

7.1.4 VENDOR REGISTER ACCESS

The vendor specific registers include the range from 30h to 3Fh. These can be accessed by the ULPI immediate register read / write.

7.1.4.1 HS TX Boost

Address = 31h (read / write)

Field name	Bit	Access	Default	Description
<i>Reserved</i>	4:0	rd	00000b	Read only, 0.
<i>Boost</i>	6:5	rd/w	00b	Sets the HS transmitter amplitude as described in Section 5.2.1 . 00b: Nominal 01b: Reserved 10b: Enables 7.4% increased drive strength 11b: Enables 3.7% increased drive strength
<i>Reserved</i>	7	rd	0b	Read only, 0.

7.1.4.2 Headset Audio Mode

Address = 33h (read / write)

Field name	Bit	Access	Default	Description
<i>HeadsetAudioEn</i>	3:0	rd/w	0000b	When this field is set to a value of 1010, the Headset Audio Mode is enabled as described in Section 6.6 .
<i>Reserved</i>	7:4	rd	0h	Read only, 0.

7.1.4.3 Vendor Rid Conversion

Address = 36-38h (read), 36h (write), 37h (set), 38h (clear)

Field name	Bit	Access	Default	Description
<i>RidValue</i>	2:0	rd/w	000b	Conversion value of Rid resistor 000: 0 Ω 001: 75 Ω 010: 100 k Ω 011: 200 k Ω 100: 440 k Ω 101: ID floating 111: Error Note: <i>RidValue</i> can also be read from the Carkit Interrupt Status register described in Section 7.1.2.3 .
<i>RidConversionDone</i>	3	rd*	0b	Automatically asserted by the USB3315 when the Rid Conversion is finished. The conversion will take 282 μ s. This bit will auto clear when the <i>RidValue</i> is read from the Rid Conversion Register. Reading the <i>RidValue</i> from the Carkit interrupt Status register will not clear either <i>RidConversionDone</i> status bit. Note: <i>RidConversionDone</i> can also be read from the Carkit Interrupt Status register described in Section 7.1.2.3 .

USB3315

Field name	Bit	Access	Default	Description
<i>RidConversionStart</i>	4	rd/w/s/c	0b	When this bit is asserted either through a register write or set, the Rid converter will read the value of the ID resistor. When the conversion is complete this bit will auto clear.
<i>Reserved</i>	5	rd/w/s/c	0b	This bit must remain at 0.
<i>RidIntEn</i>	6	rd/w/s/c	0b	When enabled an interrupt will be generated on the <i>alt_int</i> of the RXCMD byte when <i>RidConversionDone</i> bit is asserted. Note: This register bit is OR'ed with the <i>RidIntEn</i> bit of the Carkit Interrupt Status register.
<i>Reserved</i>	7	rd	0b	Read only, 0.

Note: rd*: Read Only with auto clear.

7.1.4.4 USB IO & Power Management

Address = 39-3Bh (read), 39h (write), 3Ah (set), 3Bh (clear)

Field name	Bit	Access	Default	Description
<i>Reserved</i>	0	rd/w/s/c	0b	Read only, 0.
<i>SwapDP/DM</i>	1	rd/w/s/c	0b	When asserted, the DP and DM pins of the USB PHY are swapped. This bit can be used to prevent crossing the DP/DM traces on the board. In UART mode, it swaps the routing to the DP and DM pins.
<i>UART RegOutput</i>	3:2	rd/w/s/c	01b	Controls the output voltage of the VBAT to VDD33 regulator in UART mode. When the PHY is switched from USB mode to UART mode regulator output will automatically change to the value specified in this register when <i>TxdEn</i> is asserted. 00: 3.3 V 01: 3.0 V (default) 10: 2.75 V 11: 2.5 V
<i>ChargerPullupEnDP</i>	4	rd/w/s/c	0b	Enables a 125 k Ω pull-up for USB Charger Detection when set on the DP pin. (The pull-up is automatically enabled in UART mode)
<i>ChargerPullupEnDM</i>	5	rd/w/s/c	0b	Enables a 125 k Ω pull-up for USB Charger Detection when set on the DM pin. (The pull-up is automatically enabled in UART mode)
<i>USB RegOutput</i>	7:6	rd/w/s/c	00b	Controls the output voltage of the VBAT to VDD33 regulator in USB mode. When the PHY is in Synchronous Mode, Serial Mode, or Low Power Mode the regulator output will be the value specified in this register. 00: 3.3 V (default) 01: 3.0 V 10: 2.75 V 11: 2.5 V

8.0 APPLICATIONS NOTES

8.1 Application Diagram

The USB3315 requires few external components as shown in the application diagram. In some applications, the power supplied on the VBUS pin of the USB connector is used as the source of system power. The USB 2.0 Specification restricts the voltage at the VBUS pin to a maximum value of 5.25 V. In some applications, it may be required to provide protection to the USB331x VBUS pin and VBAT pin if the VBUS voltage exceeds USB 2.0 specifications.

One method of protecting the **VBUS** pin from excessive voltage transients is to place a resistor (R_{VBUS}) in series as shown in the application diagram. The resistor provides some protection against transients that exceed the value of V_{VMAX} provided in [Table 3-2](#). This resistor can be used when the USB3315 is powered from a Battery as shown in [Figure 5-4](#) or from a 3.3 V Supply as shown in [Figure 5-5](#). When R_{VBUS} is installed, the transient must not be allowed to exceed the value of V_{VBUS} for longer than 500 μ s.

To protect the **VBUS** pin against a steady state voltage on the USB connector that exceed the value of V_{VMAX} provided in [Table 3-2](#), an Over Voltage Protection (OVP) component could be used in the place of R_{VBUS} .

Following POR or hardware reset, the voltage at **CLKOUT** must not exceed V_{IH_ED} as provided in [Table 4-4](#).

TABLE 8-1: COMPONENT VALUES IN APPLICATION DIAGRAMS

Reference Designator	Value	Description	Notes
C_{OUT}	2.2 μ F	Bypass capacitor to ground (<1 Ω ESR) for regulator stability.	Place as close as possible to the PHY.
C_{VBUS}	See Table 8-2	Capacitor to ground required by the USB Specification. Microchip recommends <1 Ω ESR.	Place near the USB connector.
C_{BYP}	System dependent.	Bypass capacitor to ground. Typical values used are 0.1 or 0.01 μ F.	Place as close as possible to the PHY.
C_{DC_LOAD}	System dependent.	The USB connector housing may be AC-coupled to the device ground.	Industry convention is to ground only the host side of the cable shield.
R_{VBUS}	820 Ω or 10 k Ω	Series resistor to reduce transient voltage on VBUS. 820 Ω in Host or OTG applications. 10 k Ω may be used only in device mode applications.	Cannot be used when the USB3315 is powered from the VBUS at the USB connector. This method of powering is shown in Figure 5-6 .

TABLE 8-2: CAPACITANCE VALUES AT VBUS OF USB CONNECTOR

Mode	MIN Value	MAX Value
Host	120 μ F	
Device	1 μ F	10 μ F
OTG	1 μ F	6.5 μ F

USB3315

FIGURE 8-1: USB3315 QFN APPLICATION DIAGRAM (DEVICE)

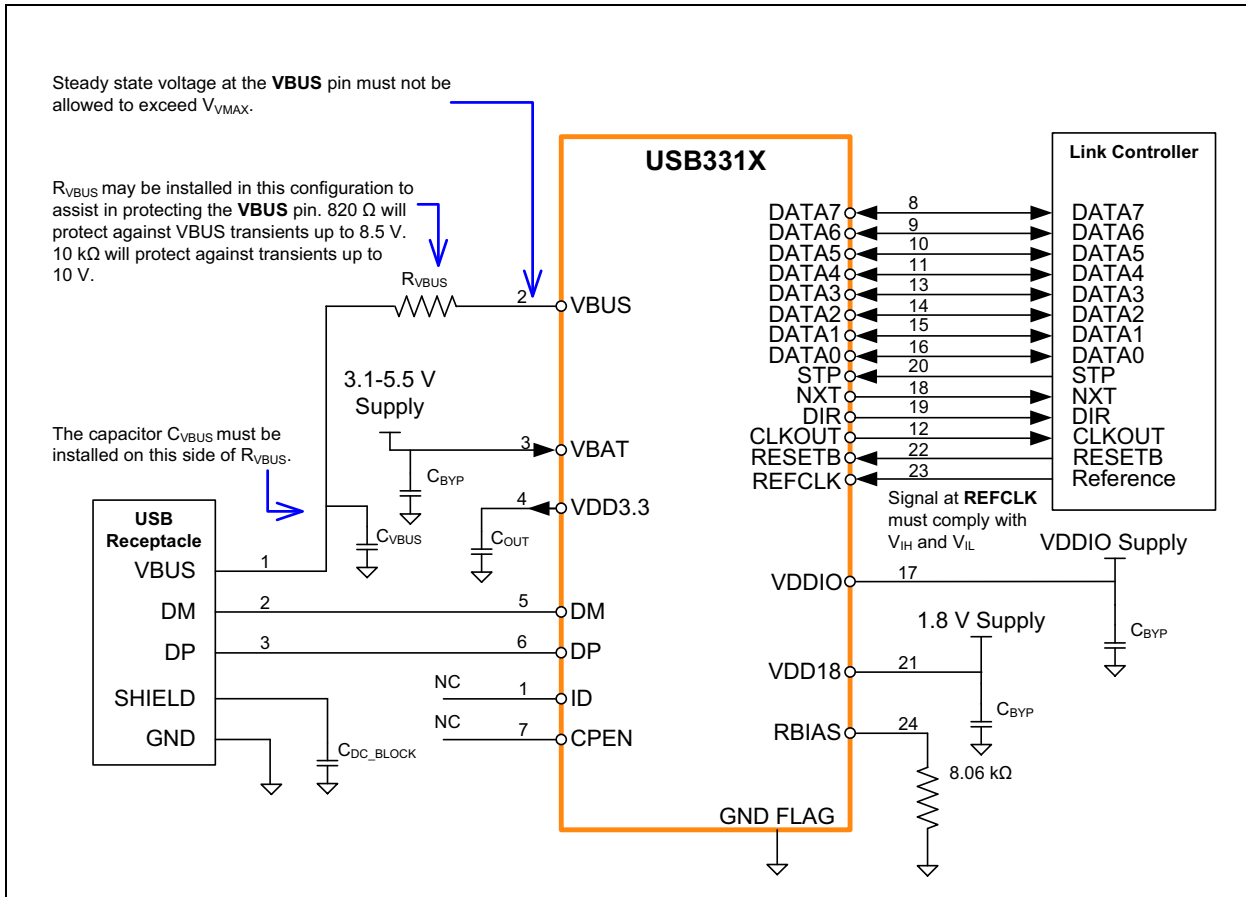
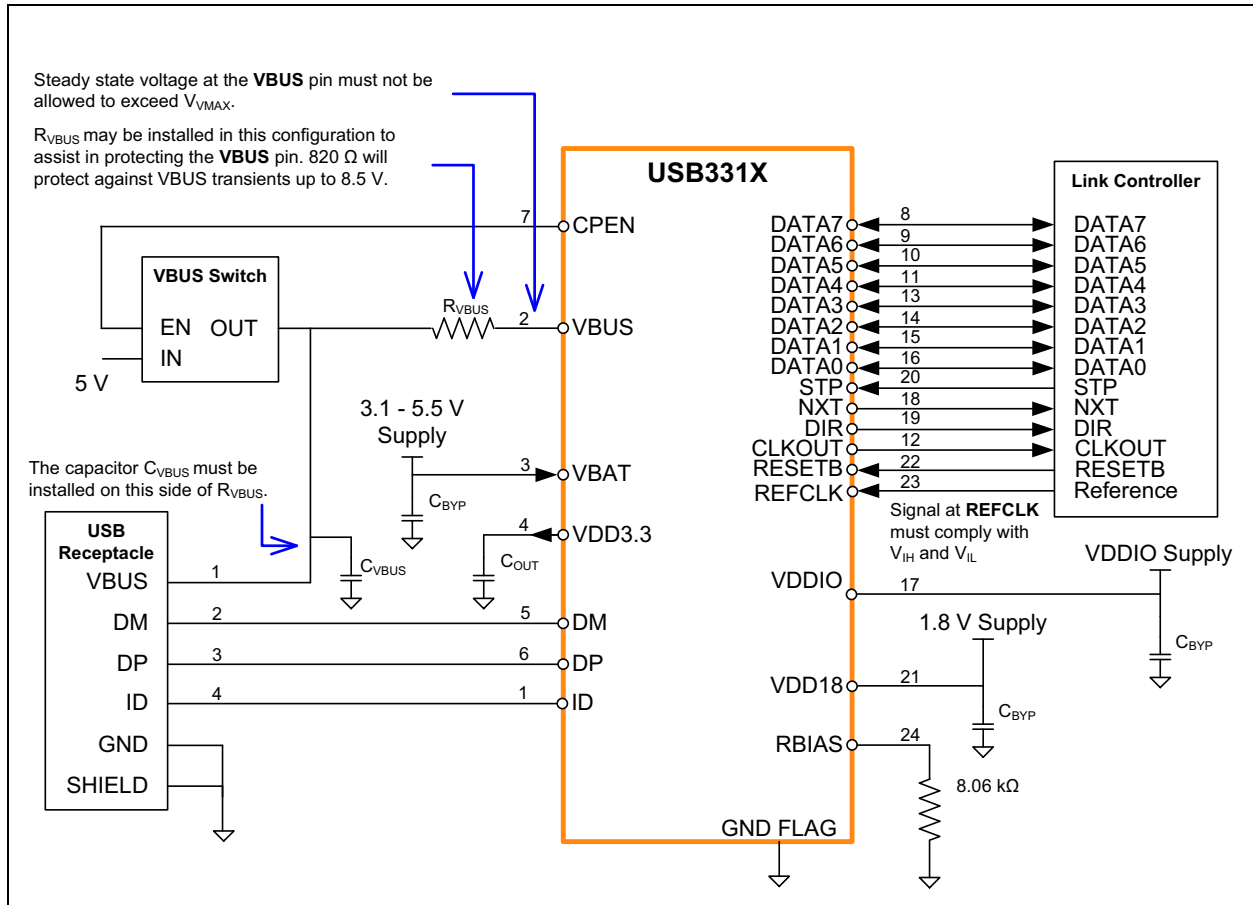

FIGURE 8-2: USB3315 QFN APPLICATION DIAGRAM (HOST OR OTG)



8.2 USB Charger Detection

Note: Microchip does not build, specify, design, or sell USB chargers. The following section is provided as a reference to the end user so that they may implement a USB Charger detection method that will work with the chargers selected to work with their end product.

The examples below are illustrated for reference only and are not intended to dictate a standard for a USB Charger. The charger and detection method must be chosen to work together.

When attached to a USB Host the device is only allowed to draw 100 mA until the completion of USB enumeration. The USB3315 includes features that can be used to differentiate between a USB Host and a Charger.

8.2.1 DETECTING THE ID RESISTOR IN A CHARGER

The ID Resistor Detection feature of the USB3315 described in [Section 5.6.1.2](#) may be used to detect a resistor to ground. Some charger manufacturers use 100 kΩ to ground at the ID pin of the USB connector.

Pseudo Algorithm for detecting resistor to ground and reading value

```

Wait for IdGnd
Enable IdPullup
Set RidConversionStart
Wait for RidConversionDone
Read RidValue
    
```

USB3315

8.2.2 DETECTING DP SHORTED TO DM

USB Chargers and USB Hosts will present 5 V nominal onto the Vbus terminal of the USB connector at all times. While in synchronous mode, the Link can detect *SessVld* in the RXCMD byte as shown in [Table 6-3](#). In any of the non-synchronous modes, the Link must monitor the interrupt signal on DATA[3] as described in [Table 6-4](#). When an interrupt occurs, the Link commands the USB3315 to exit Low Power Mode and reads registers to discover what caused the interrupt.

In preparation for testing if a charger has connected the DP and DM pins in the USB connector, the **DP** and **DM** pins of the USB3315 must be placed into Non-Driving, FS mode using the Full Speed transceivers. This is done by writing 49h to the [Function Control](#) register at address 04h. Next, pull-up resistors can be enabled on the **DP** and **DM** pins. As described in [Section 5.8](#), the pull-up resistors may be enabled individually. For example, setting bit 4 in the [USB IO & Power Management](#) register at address 3Ah will connect the *ChargerPullupEnableDP* resistor. Likewise, a write to the [USB IO & Power Management](#) register at address 3Ah with a 20h will connect the *ChargerPullupEnableDM* resistor.

The linestate signals are monitored to determine whether the **DP** and **DM** pins are shorted. While in synchronous mode, the Link can monitor *Linestate0* and *Linestate1* in the RXCMD byte as shown in [Table 6-3](#), or by reading the [Debug](#) register. In any of the non-synchronous modes, the Link can monitor linestate on DATA[0] and DATA[1] as described in [Table 6-3](#). The DC Electrical Characteristics of the Single-Ended Receivers used to generate the linestate signals are provided in [Table 4-6](#).

Pseudo Algorithm for detecting voltage at Vbus and detecting DP shorted to DM

```
Wait for SessVld
Tri-State DP/DM and select FS transceivers
Enable ChargerPullupEnableDP resistor
Enable ChargerPullupEnableDM resistor
If the linestates show a SE1 the charger has been detected.
If the linestates show an SE0 you are connected to a host.
```

8.3 Reference Designs

Microchip has generated reference designs for connecting the USB3315 to SOCs with a ULPI port. Please contact the Microchip sales office for more details.

8.4 ESD Performance

The USB3315 is protected from ESD strikes. By eliminating the requirement for external ESD protection devices, board space is conserved, and the board manufacturer is enabled to reduce cost. The advanced ESD structures integrated into the USB3315 protect the device whether or not it is powered up.

8.4.1 HUMAN BODY MODEL (HBM) PERFORMANCE

HBM testing verifies the ability to withstand the ESD strikes like those that occur during handling and manufacturing, and is done without power applied to the IC. To pass the test, the device must have no change in operation or performance due to the event. All pins on the USB3315 except the **REFCLK** pin provide ± 8 kV HBM protection, as shown in [Table 4-9](#).

8.4.2 EN/IEC 61000-4-2 PERFORMANCE

The EN/IEC 61000-4-2 ESD specification is an international standard that addresses system-level immunity to ESD strikes while the end equipment is operational. In contrast, the HBM ESD tests are performed at the device level with the device powered down.

Microchip contracts with Independent laboratories to test the USB3315 to EN/IEC 61000-4-2 in a working system. Reports are available upon request. Please contact your Microchip representative, and request information on 3rd party ESD test results. The reports show that systems designed with the USB3315 can safely provide the ESD performance shown in [Table 4-9](#) without additional board level protection.

In addition to defining the ESD tests, EN/IEC 61000-4-2 also categorizes the impact to equipment operation when the strike occurs (ESD Result Classification). The USB3315 maintains an ESD Result Classification 1 or 2 when subjected to an EN/IEC 61000-4-2 (level 4) ESD strike.

Both air discharge and contact discharge test techniques for applying stress conditions are defined by the EN/IEC 61000-4-2 ESD document.

8.4.3 AIR DISCHARGE

To perform this test, a charged electrode is moved close to the system being tested until a spark is generated. This test is difficult to reproduce because the discharge is influenced by such factors as humidity, the speed of approach of the electrode, and construction of the test equipment.

8.4.4 CONTACT DISCHARGE

The uncharged electrode first contacts the USB connector to prepare this test, and then the probe tip is energized. This yields more repeatable results, and is the preferred test method. The independent test laboratories contracted by Microchip provide test results for both types of discharge methods.

USB3315

9.0 PACKAGE OUTLINE

Note: For the most current package drawings, see the Microchip Packaging Specification at: <http://www.microchip.com/packaging>.

FIGURE 9-1: USB3315 24-PIN VQFN PACKAGE OUTLINE

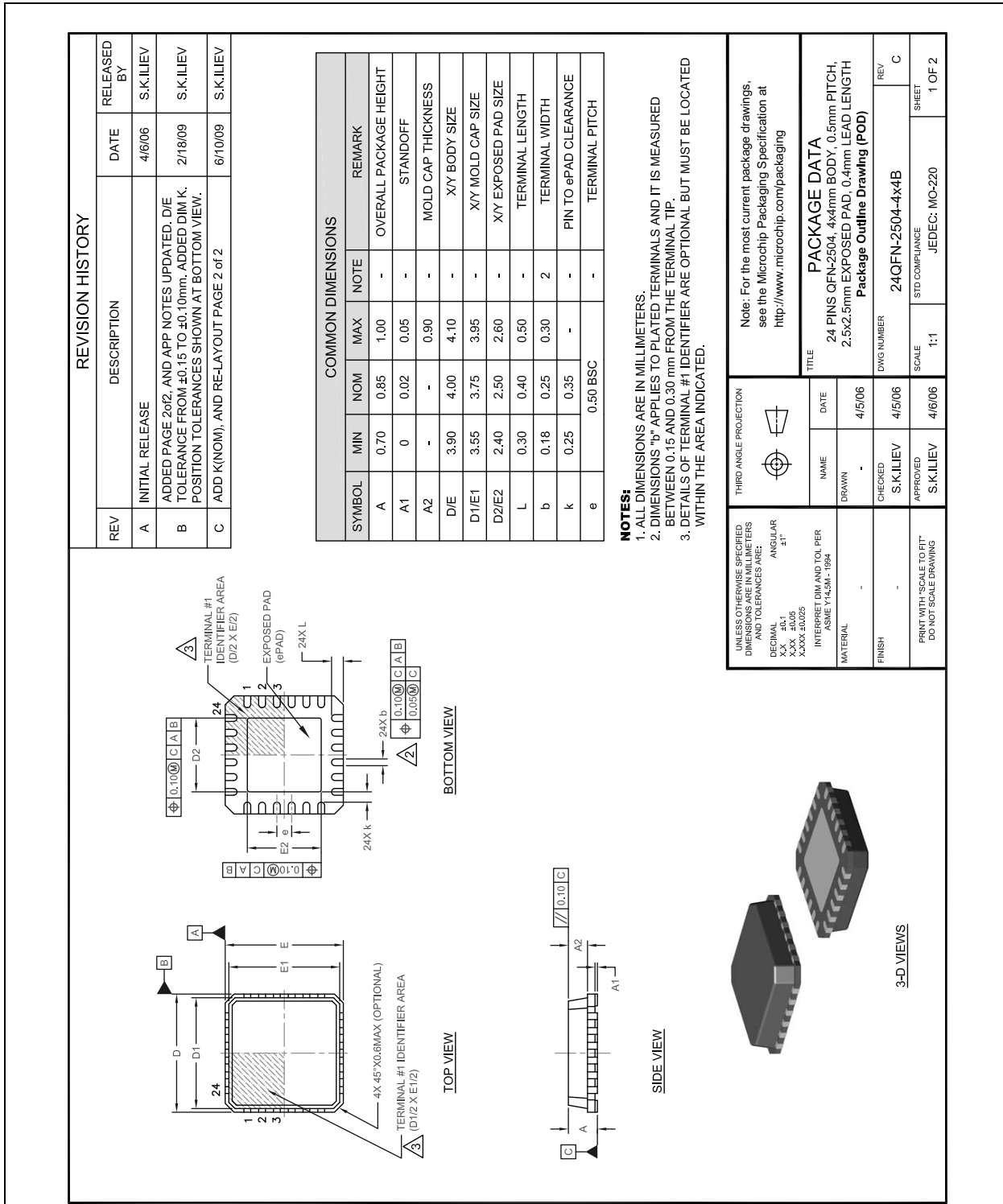

FIGURE 9-3: QFN, 4X4 TAPE & REEL

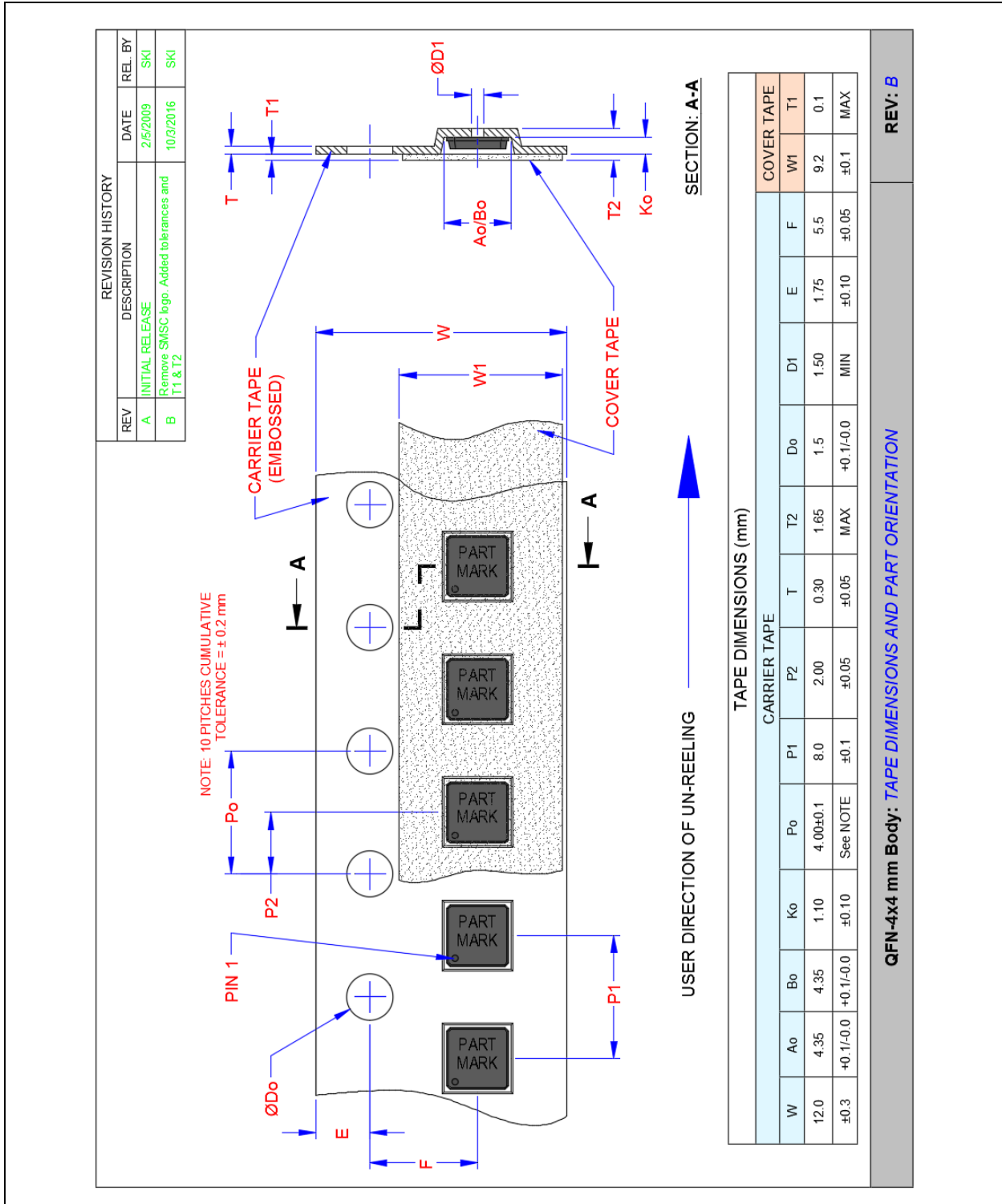

FIGURE 9-4: REEL DIMENSIONS

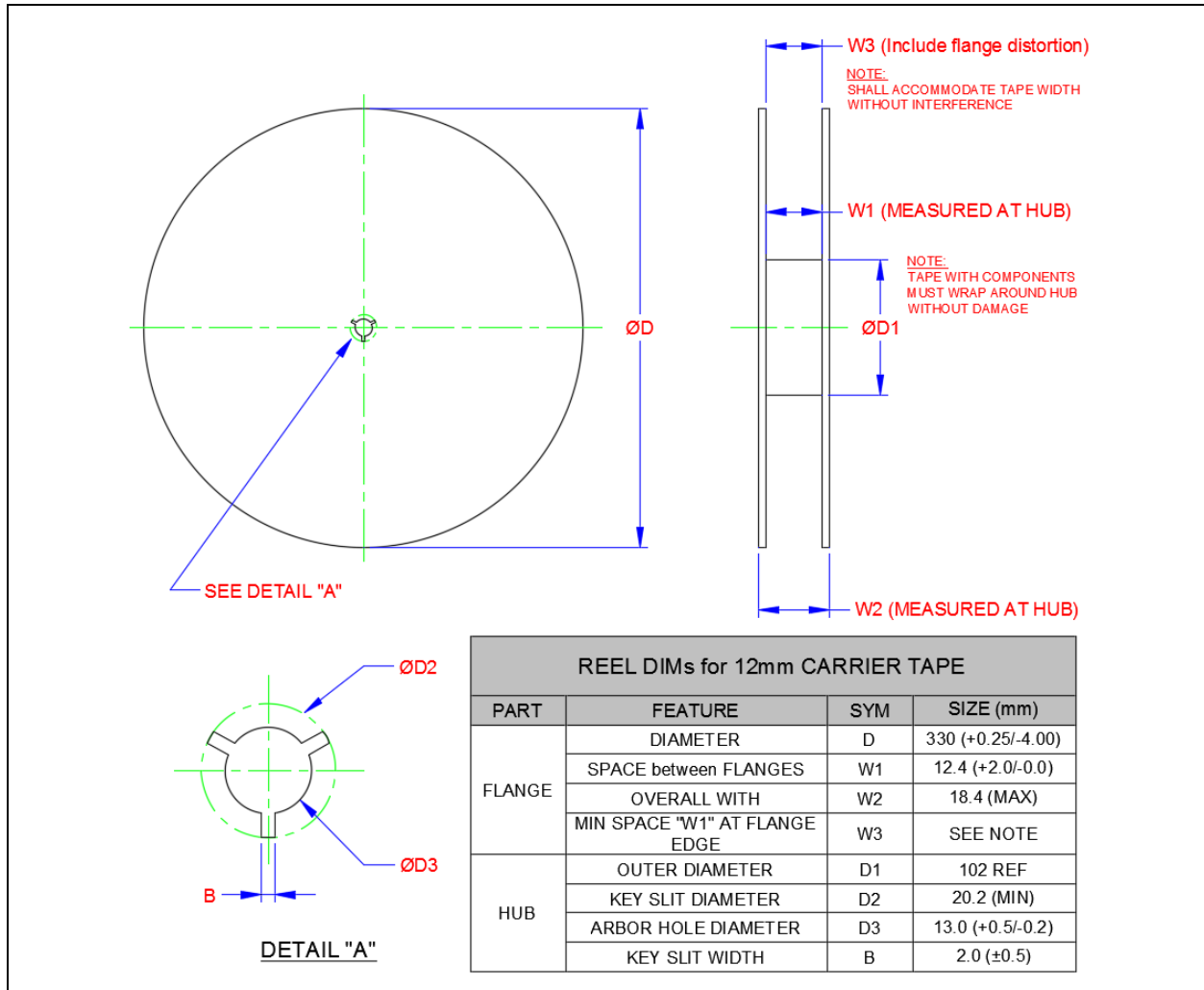
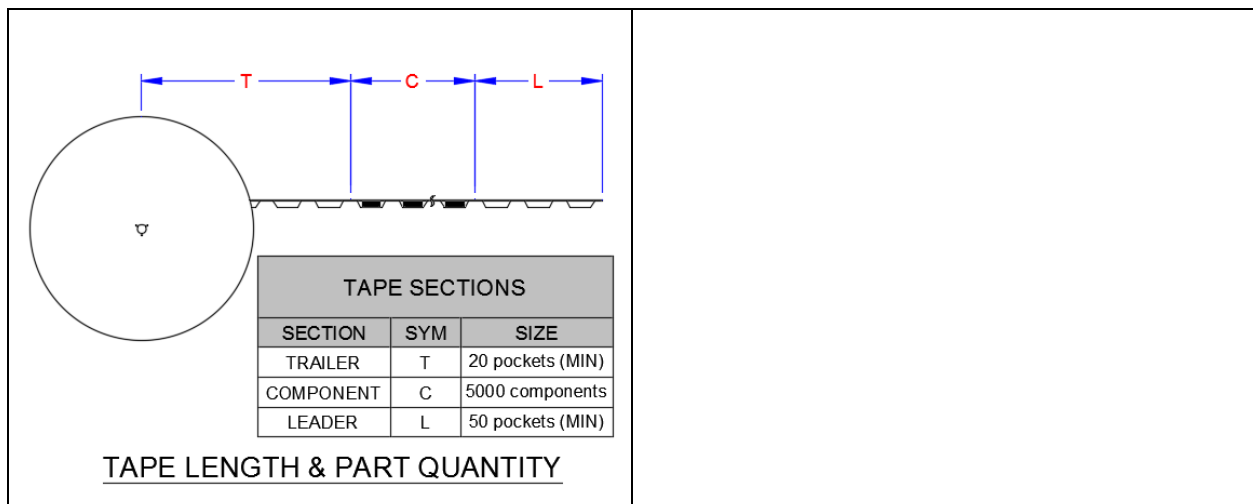
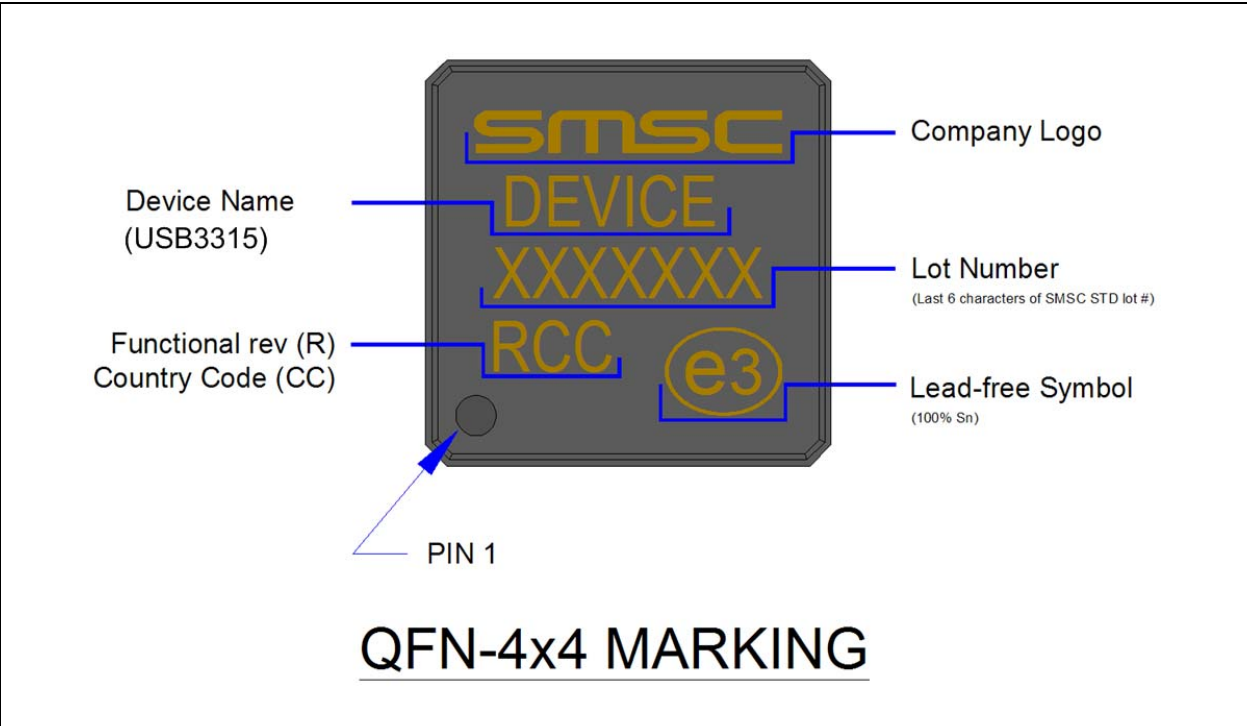

FIGURE 9-5: TAPE SECTIONS (24-PIN QFN LEFT)



USB3315

FIGURE 9-6: QFN, 4X4 PACKAGE MARKING



APPENDIX A: DATA SHEET REVISION HISTORY

TABLE A-1: CUSTOMER REVISION HISTORY

Revision Level & Date	Section/Figure/Entry	Correction
DS00002364A (03-20-17)	All	Version migrated to Microchip template. Microchip DS number inserted. Revision A replaces the previous SMSC Rev 1.2. Package drawing exchanged according to Microchip standard.
	Section 2.1	Row RESETB: value of Active Level changed from N/A -> Low
Rev 2.1 (06-02-10)	Cover Section	Changed references to OTG Specification Revision 1.3 to Revision 2.0.
	Chapter 5.0	Removed Note 5.3.
	Section 7.1.4.1	Removed -3.7% TX Boost.
	Section 6.6, Section 7.1	Added Headset Audio Mode definition.
Rev 2.0 (08-03-09)	Table 4-3	Changed Tdc, Tdd MIN to 1.5ns.
	Table 5-2	Added note.
	Figure 5-8	Corrected polarity of IdGnd Comparator.
	Table 5-4	Corrections made to column "IDGND".
	Table 6-3	Modified definition of ID bit.
Rev. 1.11 (10-31-08)	Table 4-4	Formula in MAX column for CLKOUT External Drive changed from " $0.68 * V_{DDIO}$ " to " $0.4 * V_{DDIO}$ "
Rev. 1.11 (10-28-08)	Table 2-1	Added the following note in description for CLKOUT: "Following POR or hardware reset, the voltage at CLKOUT must not exceed V_{IH_ED} as provided in Table 4-4 ."
Rev. 1.11 (10-28-08)	Section 8.1	Paragraph added: Following POR or hardware reset, the voltage at CLKOUT must not exceed V_{IH_ED} as provided in Table 4-4 .
Rev. 1.11 (10-28-08)	Section 5.4	Paragraph added: "The system must not drive voltage on the CLKOUT pin following POR or hardware reset that exceeds the value of V_{IH_ED} provided in Table 4-4 ."
Rev. 1.11 (10-28-08)	Table 4-4	Table title changed from "Electrical Characteristics - Digital IO Pins: RESETB, STP, DIR, NXT, DATA[7:0] & REFCLK Pins" to: "Digital IO Characteristics: RESETB, CLKOUT, STP, DIR, NXT, DATA[7:0] and XI Pins" Row added - "CLKOUT External Drive"
Rev. 1.11 (10-27-08)	Section 5.2.1	Added paragraph for further clarification

TABLE A-1: CUSTOMER REVISION HISTORY (CONTINUED)

Revision Level & Date	Section/Figure/Entry	Correction
Rev. 1.11 (10-27-08)	Table 7-1 and Section 7.1.4.1	Added "HS TX Boost" register
Rev. 1.11 (10-27-08)	Section 8.2.2	Section modified
Rev. 1.10 (08-08-08)	Initial Release	
Rev. 1.10 (07-25-08)	Section 7.1.1.3	Default column changed from "01h" to "06h"
Rev. 1.10 (07-09-08)	Section 7.1.1.10	Changed from : "Address = 13h (read only with auto clear)" to: "Address = 13h (read only)"; Note removed
Rev. 1.9 (06-23-08)		Changed conditions for synchronous mode to: Start-up sequence defined in Section 5.5.4 , "Start-Up" has completed.
Rev. 1.9 (06-19-08)	Chapter 4.0	Changed conditions at beginning of chapter to include V_{VBAT} .
Rev. 1.9 (06-19-08)	Table 3-2	Made separate entry for V_{VBAT} and V_{BUS} . For normal operation, V_{VBAT} cannot be zero.
Rev. 1.8 (05-02-08)	Section 5.6	Changed Mini-AB connector to Micro-AB receptacle.

APPENDIX B: REFERENCES

- [1] Universal Serial Bus Specification, Revision 2.0, April 27, 2000
- [2] On-The-Go Supplement to the USB 2.0 Specification, Revision 2.0, May 8, 2009
- [3] 27% Resistor ECN
- [4] USB 2.0 Transceiver Macrocell Interface (UTMI) Specification, Version 1.02, May 27, 2000
- [5] UTMI+ Specification, Revision 1.0, February 2, 2004
- [6] UTMI+ Low Pin Interface (ULPI) Specification, Revision 1.1, October 20, 2004
- [7] Technical Requirements and Test Methods of Charger and Interface for Mobile Telecommunication Terminal Equipment (Chinese Charger Specification Approval Draft 11/29/2006)

USB3315

THE MICROCHIP WEB SITE

Microchip provides online support via our WWW site at www.microchip.com. This web site is used as a means to make files and information easily available to customers. Accessible by using your favorite Internet browser, the web site contains the following information:

- **Product Support** – Data sheets and errata, application notes and sample programs, design resources, user's guides and hardware support documents, latest software releases and archived software
- **General Technical Support** – Frequently Asked Questions (FAQ), technical support requests, online discussion groups, Microchip consultant program member listing
- **Business of Microchip** – Product selector and ordering guides, latest Microchip press releases, listing of seminars and events, listings of Microchip sales offices, distributors and factory representatives

CUSTOMER CHANGE NOTIFICATION SERVICE

Microchip's customer notification service helps keep customers current on Microchip products. Subscribers will receive e-mail notification whenever there are changes, updates, revisions or errata related to a specified product family or development tool of interest.

To register, access the Microchip web site at www.microchip.com. Under "Support", click on "Customer Change Notification" and follow the registration instructions.

CUSTOMER SUPPORT

Users of Microchip products can receive assistance through several channels:

- Distributor or Representative
- Local Sales Office
- Field Application Engineer (FAE)
- Technical Support

Customers should contact their distributor, representative or field application engineer (FAE) for support. Local sales offices are also available to help customers. A listing of sales offices and locations is included in the back of this document.

Technical support is available through the web site at: <http://microchip.com/support>

PRODUCT IDENTIFICATION SYSTEM

To order or obtain information, e.g., on pricing or delivery, refer to the factory or the listed sales office.

<p>PART NO.</p> <p>↓</p> <p>Device</p>	-	<p>X</p> <p>↑</p> <p>Package</p>	-	<p>X⁽¹⁾</p> <p>↑</p> <p>Tape and Reel Option</p>	<p>Examples:</p> <p>a) USB3315C-CP-TR, VQFN (24-pin), Tape and Reel</p>
<p>Device: USB3315C</p>					
<p>Package:: CP = VQFN (24-pin)</p>					
<p>Tape and Reel Option: TR = Tape and Reel⁽¹⁾</p>					<p>Note 1: Tape and Reel identifier only appears in the catalog part number description. This identifier is used for ordering purposes and is not printed on the device package. Check with your Microchip Sales Office for package availability with the Tape and Reel option.</p>

USB3315

Note the following details of the code protection feature on Microchip devices:

- Microchip products meet the specification contained in their particular Microchip Data Sheet.
- Microchip believes that its family of products is one of the most secure families of its kind on the market today, when used in the intended manner and under normal conditions.
- There are dishonest and possibly illegal methods used to breach the code protection feature. All of these methods, to our knowledge, require using the Microchip products in a manner outside the operating specifications contained in Microchip's Data Sheets. Most likely, the person doing so is engaged in theft of intellectual property.
- Microchip is willing to work with the customer who is concerned about the integrity of their code.
- Neither Microchip nor any other semiconductor manufacturer can guarantee the security of their code. Code protection does not mean that we are guaranteeing the product as "unbreakable."

Code protection is constantly evolving. We at Microchip are committed to continuously improving the code protection features of our products. Attempts to break Microchip's code protection feature may be a violation of the Digital Millennium Copyright Act. If such acts allow unauthorized access to your software or other copyrighted work, you may have a right to sue for relief under that Act.

Information contained in this publication regarding device applications and the like is provided only for your convenience and may be superseded by updates. It is your responsibility to ensure that your application meets with your specifications. MICROCHIP MAKES NO REPRESENTATIONS OR WARRANTIES OF ANY KIND WHETHER EXPRESS OR IMPLIED, WRITTEN OR ORAL, STATUTORY OR OTHERWISE, RELATED TO THE INFORMATION, INCLUDING BUT NOT LIMITED TO ITS CONDITION, QUALITY, PERFORMANCE, MERCHANTABILITY OR FITNESS FOR PURPOSE. Microchip disclaims all liability arising from this information and its use. Use of Microchip devices in life support and/or safety applications is entirely at the buyer's risk, and the buyer agrees to defend, indemnify and hold harmless Microchip from any and all damages, claims, suits, or expenses resulting from such use. No licenses are conveyed, implicitly or otherwise, under any Microchip intellectual property rights unless otherwise stated.

Trademarks

The Microchip name and logo, the Microchip logo, AnyRate, AVR, AVR logo, AVR Freaks, BeaconThings, BitCloud, CryptoMemory, CryptoRF, dsPIC, FlashFlex, flexPWR, Heldo, JukeBlox, KEELOQ, KEELOQ logo, Kleer, LANCheck, LINK MD, maXStylus, maXTouch, MediaLB, megaAVR, MOST, MOST logo, MPLAB, OptoLyzer, PIC, picoPower, PICSTART, PIC32 logo, Prochip Designer, QTouch, RightTouch, SAM-BA, SpyNIC, SST, SST Logo, SuperFlash, tinyAVR, UNI/O, and XMEGA are registered trademarks of Microchip Technology Incorporated in the U.S.A. and other countries.

ClockWorks, The Embedded Control Solutions Company, EtherSynch, Hyper Speed Control, HyperLight Load, IntelliMOS, mTouch, Precision Edge, and Quiet-Wire are registered trademarks of Microchip Technology Incorporated in the U.S.A.

Adjacent Key Suppression, AKS, Analog-for-the-Digital Age, Any Capacitor, AnyIn, AnyOut, BodyCom, chipKIT, chipKIT logo, CodeGuard, CryptoAuthentication, CryptoCompanion, CryptoController, dsPICDEM, dsPICDEM.net, Dynamic Average Matching, DAM, ECAN, EtherGREEN, In-Circuit Serial Programming, ICSP, Inter-Chip Connectivity, JitterBlocker, KleerNet, KleerNet logo, Mindi, MiWi, motorBench, MPASM, MPF, MPLAB Certified logo, MPLIB, MPLINK, MultiTRAK, NetDetach, Omniscient Code Generation, PICDEM, PICDEM.net, PICkit, PICtail, PureSilicon, QMatrix, RightTouch logo, REAL ICE, Ripple Blocker, SAM-ICE, Serial Quad I/O, SMART-I.S., SQI, SuperSwitcher, SuperSwitcher II, Total Endurance, TSHARC, USBCheck, VariSense, ViewSpan, WiperLock, Wireless DNA, and ZENA are trademarks of Microchip Technology Incorporated in the U.S.A. and other countries.

SQTP is a service mark of Microchip Technology Incorporated in the U.S.A.

Silicon Storage Technology is a registered trademark of Microchip Technology Inc. in other countries.

GestIC is a registered trademark of Microchip Technology Germany II GmbH & Co. KG, a subsidiary of Microchip Technology Inc., in other countries.

All other trademarks mentioned herein are property of their respective companies.

© 2008-2017, Microchip Technology Incorporated, All Rights Reserved.

ISBN: 978-1-5224-0964-9

QUALITY MANAGEMENT SYSTEM
CERTIFIED BY DNV
== ISO/TS 16949 ==

Microchip received ISO/TS-16949:2009 certification for its worldwide headquarters, design and wafer fabrication facilities in Chandler and Tempe, Arizona; Gresham, Oregon and design centers in California and India. The Company's quality system processes and procedures are for its PIC® MCUs and dsPIC® DSCs, KEELoQ® code hopping devices, Serial EEPROMs, microperipherals, nonvolatile memory and analog products. In addition, Microchip's quality system for the design and manufacture of development systems is ISO 9001:2000 certified.



Worldwide Sales and Service

AMERICAS

Corporate Office
2355 West Chandler Blvd.
Chandler, AZ 85224-6199
Tel: 480-792-7200
Fax: 480-792-7277
Technical Support:
<http://www.microchip.com/support>
Web Address:
www.microchip.com

Atlanta
Duluth, GA
Tel: 678-957-9614
Fax: 678-957-1455

Austin, TX
Tel: 512-257-3370

Boston
Westborough, MA
Tel: 774-760-0087
Fax: 774-760-0088

Chicago
Itasca, IL
Tel: 630-285-0071
Fax: 630-285-0075

Dallas
Addison, TX
Tel: 972-818-7423
Fax: 972-818-2924

Detroit
Novi, MI
Tel: 248-848-4000

Houston, TX
Tel: 281-894-5983

Indianapolis
Noblesville, IN
Tel: 317-773-8323
Fax: 317-773-5453
Tel: 317-536-2380

Los Angeles
Mission Viejo, CA
Tel: 949-462-9523
Fax: 949-462-9608
Tel: 951-273-7800

Raleigh, NC
Tel: 919-844-7510

New York, NY
Tel: 631-435-6000

San Jose, CA
Tel: 408-735-9110
Tel: 408-436-4270

Canada - Toronto
Tel: 905-695-1980
Fax: 905-695-2078

ASIA/PACIFIC

Asia Pacific Office
Suites 3707-14, 37th Floor
Tower 6, The Gateway
Harbour City, Kowloon

Hong Kong
Tel: 852-2943-5100
Fax: 852-2401-3431

Australia - Sydney
Tel: 61-2-9868-6733
Fax: 61-2-9868-6755

China - Beijing
Tel: 86-10-8569-7000
Fax: 86-10-8528-2104

China - Chengdu
Tel: 86-28-8665-5511
Fax: 86-28-8665-7889

China - Chongqing
Tel: 86-23-8980-9588
Fax: 86-23-8980-9500

China - Dongguan
Tel: 86-769-8702-9880

China - Guangzhou
Tel: 86-20-8755-8029

China - Hangzhou
Tel: 86-571-8792-8115
Fax: 86-571-8792-8116

China - Hong Kong SAR
Tel: 852-2943-5100
Fax: 852-2401-3431

China - Nanjing
Tel: 86-25-8473-2460
Fax: 86-25-8473-2470

China - Qingdao
Tel: 86-532-8502-7355
Fax: 86-532-8502-7205

China - Shanghai
Tel: 86-21-3326-8000
Fax: 86-21-3326-8021

China - Shenyang
Tel: 86-24-2334-2829
Fax: 86-24-2334-2393

China - Shenzhen
Tel: 86-755-8864-2200
Fax: 86-755-8203-1760

China - Wuhan
Tel: 86-27-5980-5300
Fax: 86-27-5980-5118

China - Xian
Tel: 86-29-8833-7252
Fax: 86-29-8833-7256

ASIA/PACIFIC

China - Xiamen
Tel: 86-592-2388138
Fax: 86-592-2388130

China - Zhuhai
Tel: 86-756-3210040
Fax: 86-756-3210049

India - Bangalore
Tel: 91-80-3090-4444
Fax: 91-80-3090-4123

India - New Delhi
Tel: 91-11-4160-8631
Fax: 91-11-4160-8632

India - Pune
Tel: 91-20-3019-1500

Japan - Osaka
Tel: 81-6-6152-7160
Fax: 81-6-6152-9310

Japan - Tokyo
Tel: 81-3-6880-3770
Fax: 81-3-6880-3771

Korea - Daegu
Tel: 82-53-744-4301
Fax: 82-53-744-4302

Korea - Seoul
Tel: 82-2-554-7200
Fax: 82-2-558-5932 or
82-2-558-5934

Malaysia - Kuala Lumpur
Tel: 60-3-6201-9857
Fax: 60-3-6201-9859

Malaysia - Penang
Tel: 60-4-227-8870
Fax: 60-4-227-4068

Philippines - Manila
Tel: 63-2-634-9065
Fax: 63-2-634-9069

Singapore
Tel: 65-6334-8870
Fax: 65-6334-8850

Taiwan - Hsin Chu
Tel: 886-3-5778-366
Fax: 886-3-5770-955

Taiwan - Kaohsiung
Tel: 886-7-213-7830

Taiwan - Taipei
Tel: 886-2-2508-8600
Fax: 886-2-2508-0102

Thailand - Bangkok
Tel: 66-2-694-1351
Fax: 66-2-694-1350

EUROPE

Austria - Wels
Tel: 43-7242-2244-39
Fax: 43-7242-2244-393

Denmark - Copenhagen
Tel: 45-4450-2828
Fax: 45-4485-2829

Finland - Espoo
Tel: 358-9-4520-820

France - Paris
Tel: 33-1-69-53-63-20
Fax: 33-1-69-30-90-79

France - Saint Cloud
Tel: 33-1-30-60-70-00

Germany - Garching
Tel: 49-8931-9700

Germany - Haan
Tel: 49-2129-3766400

Germany - Heilbronn
Tel: 49-7131-67-3636

Germany - Karlsruhe
Tel: 49-721-625370

Germany - Munich
Tel: 49-89-627-144-0
Fax: 49-89-627-144-44

Germany - Rosenheim
Tel: 49-8031-354-560

Israel - Ra'anana
Tel: 972-9-744-7705

Italy - Milan
Tel: 39-0331-742611
Fax: 39-0331-466781

Italy - Padova
Tel: 39-049-7625286

Netherlands - Drunen
Tel: 31-416-690399
Fax: 31-416-690340

Norway - Trondheim
Tel: 47-7289-7561

Poland - Warsaw
Tel: 48-22-3325737

Romania - Bucharest
Tel: 40-21-407-87-50

Spain - Madrid
Tel: 34-91-708-08-90
Fax: 34-91-708-08-91

Sweden - Gothenberg
Tel: 46-31-704-60-40

Sweden - Stockholm
Tel: 46-8-5090-4654

UK - Wokingham
Tel: 44-118-921-5800
Fax: 44-118-921-5820

X-ON Electronics

Largest Supplier of Electrical and Electronic Components

Click to view similar products for [USB Interface IC](#) category:

Click to view products by [Microchip](#) manufacturer:

Other Similar products are found below :

[CY7C69356-48LTXC](#) [USB3319C-GJ-TR](#) [USB3370B-EZK-TR](#) [CYPD2120-24LQXI](#) [CYPD2122-20FNXIT](#) [CYPD2122-24LQXIT](#) [LIF-UC120-SWG36ITR50](#) [UPD360-A/6HX](#) [CP2102NP1174GM](#) [DPO2039DABQ-13](#) [CY7C68034-56LTXC](#) [TUSB212RWBT](#) [TUSB213IRGYT](#) [TUSB213RGYT](#) [USB3503T-I/ML](#) [CY7C63310-SXC](#) [USB3316C-CP-TR](#) [USB3250-ABZJ](#) [MAX3107ETG+](#) [MAX14632EZK+T](#) [LAN9514-JZX](#) [CYPD2120-24LQXIT](#) [MAX3100CEE+T](#) [USB5806/KD](#) [USB5826-I/KD](#) [USB5826/KD](#) [USB5906/KD](#) [USB5916/KD](#) [USB5926/KD](#) [TUSB215QRGYTQ1](#) [NB7NPQ701MMTTBG](#) [TUSB213RGYR](#) [USB5926-I/KD](#) [USB5906-I/KD](#) [USB4640I-HZH-03](#) [CY7C63813-SXC](#) [CY7C63823-SXC](#) [CY7C64215-28PVXC](#) [CY7C68013A-128AXC](#) [CY7C68013A-56LTXC](#) [CY7C68013A-56LTXI](#) [CY7C68013A-56PVXC](#) [CY7C68013A-56PVXI](#) [CYPD1120-40LQXI](#) [AP43771VDKZ-13](#) [AP43771VFBZ-13](#) [DIO32320MP10](#) [HT42B534-2](#) [FT2232HPQ-TRAY](#) [FT312D-32L1C-T](#)