



Helping Customers Innovate, Improve & Grow



VC-820

Description

Vectron's VC-820 Crystal Oscillator (XO) is a quartz stabilized square wave generator with a CMOS output. The VC-820 uses 3rd overtone crystals resulting in very low jitter performance, and a monolithic IC which improves reliability and reduces cost.

Features

- CMOS output XO
- 114.285MHz
- 3.3V Operation
- 3rd OT Crystal Design with low Jitter Performance
- Output Disable Feature
- Excellent 25ppm temperature stability
- -40/85°C operating temperature
- Small Industry Standard Package, 3.2x2.5x1.0mm
- Product is compliant to RoHS directive  and fully compatible with lead free assembly

Applications

- SONET/SDH/DWDM
- Ethernet, GE, SynchE
- Storage Area Networking
- Fiber Channel
- Digital Video
- Broadband Access
- Base Stations, Picocells

Block Diagram

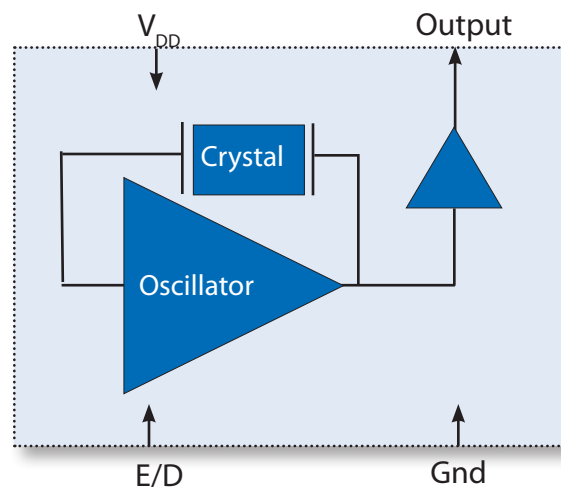

Specifications

Table 1. Electrical Performance

Parameter	Symbol	Min	Typical	Maximum	Units
Supply					
Voltage ¹	V_{DD}	3.135	3.3	3.465	V
Maximum Voltage		-0.5		5	V
Current ²	I_{DD}			30	mA
Current, Output Disabled				10	uA
Frequency					
Nominal Frequency	f_N		114.285		MHz
Stability ³				±25	ppm
Outputs					
Output Logic Levels ²					
Output Logic High	V_{OH}	1.65			V
Output Logic Low	V_{OL}			0.4	V
Output Logic High Drive	I_{OH}	8			mA
Output Logic Low Drive	I_{OL}	8			mA
Load	I_{OUT}			15	pF
Output Rise /Fall Time ²	t_R/t_F			3	ns
Output Leakage, Output Disabled	I_Z			±10	uA
Duty Cycle ^{2,4}		45		55	%
Period Jitter ⁵	ϕ_J				ps
RMS			2.4		
Peak-Peak			20		
RMS Jitter, 12k-5MHz	ϕ_J			0.1	ps
Enable/Disable					
Output Enable/Disable ⁶					
Output Enable	V_{IH}	$0.7 \cdot V_{DD}$			V
Output Disable	V_{IL}			$0.3 \cdot V_{DD}$	V
Disable time	t_D			100	ns
Start-Up Time	t_{SU}			10	ms
Operating Temp	T_{OP}	-40		85	°C

- 1] The power supply should have by-pass capacitors as close to the supply and to ground as possible, for example 0.1 and 0.01uF.
- 2] Parameters are tested with production test circuit below , Figure 1.
- 3] Includes initial accuracy, operating temperature, supply voltage and aging.
- 4] Duty Cycle is measured as On Time/Period, Figure 2.
- 5] Broadband Period Jitter measured using Wavecrest SIA3300C, 90K samples.
- 6] The Output is Enabled if the Enable/Disable is left open (100k internal pull-up resistor).

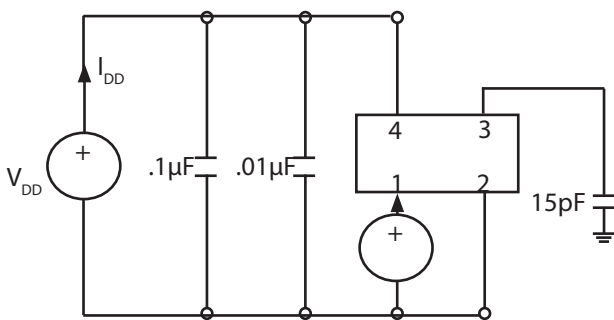

Fig 1: Test Circuit

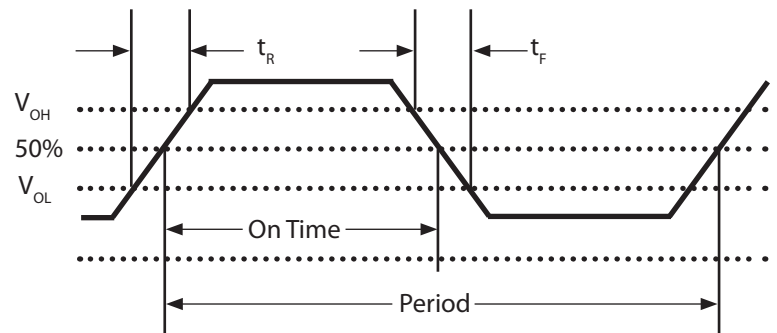
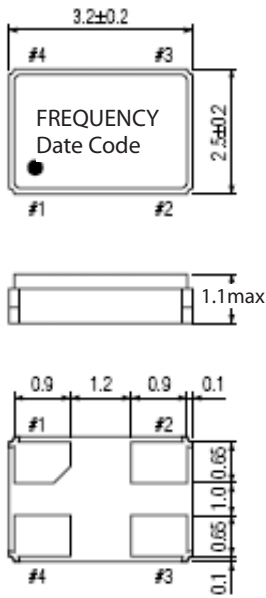

Fig 2: Waveform

Outline Drawing & Pad Layout



Dimensions in mm

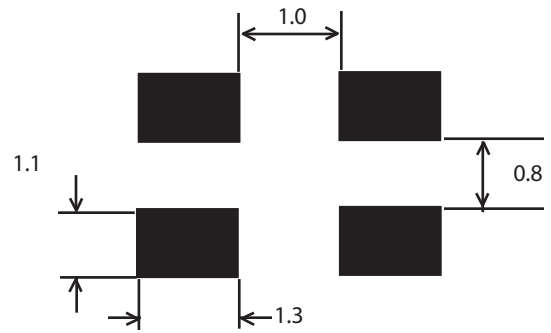

Table 2. Pin Out

Pin	Symbol	Function
1	E/D	Enable Disable
2	GND	Case and Electrical Ground
3	Output	Output
4	V _{DD}	Power Supply Voltage

Reliability

VI qualification will include aging at various extreme temperatures, shock and vibration, temperature cycling, and IR reflow simulation. The VC-820 family is capable of meeting the following qualification tests:

Table 3. Environmental Compliance

Parameter	Conditions
Mechanical Shock	MIL-STD-883, Method 2002
Mechanical Vibration	MIL-STD-883, Method 2007
Solderability	MIL-STD-883, Method 2003
Gross and Fine Leak	MIL-STD-883, Method 1014
Resistance to Solvents	MIL-STD-883, Method 2015
Moisture Sensitivity Level	MSL 1
Contact Pads	Gold over Nickel

Although ESD protection circuitry has been designed into the VC-820 proper precautions should be taken when handling and mounting. VI employs a human body model (HBM) and a charged device model (CDM) for ESD susceptibility testing and design protection evaluation.

Table 4. ESD Ratings

Model	Minimum	Conditions
Human Body Model	1500V	MIL-STD-883, Method 3015
Charged Device Model	1000V	JESD22-C101

Stresses in excess of the absolute maximum ratings can permanently damage the device. Functional operation is not implied at these or any other conditions in excess of conditions represented in the operational sections of this datasheet. Exposure to absolute maximum ratings for extended periods may adversely affect device reliability. Permanent damage is also possible if E/D is applied before V_{DD}.

Table 5. Absolute Maximum Ratings

Parameter	Symbol	Ratings	Unit
Storage Temperature	T _S	-55 to 125	°C
Soldering Temp/Time	T _{LS}	260 / 20	°C / sec

IR Reflow

Solderprofile:

The VC-820 is qualified to meet the JEDEC standard for Pb-Free assembly. The temperatures and time intervals listed are based on the Pb-Free small body requirements. The VC-820 device is hermetically sealed so an aqueous wash is not an issue.

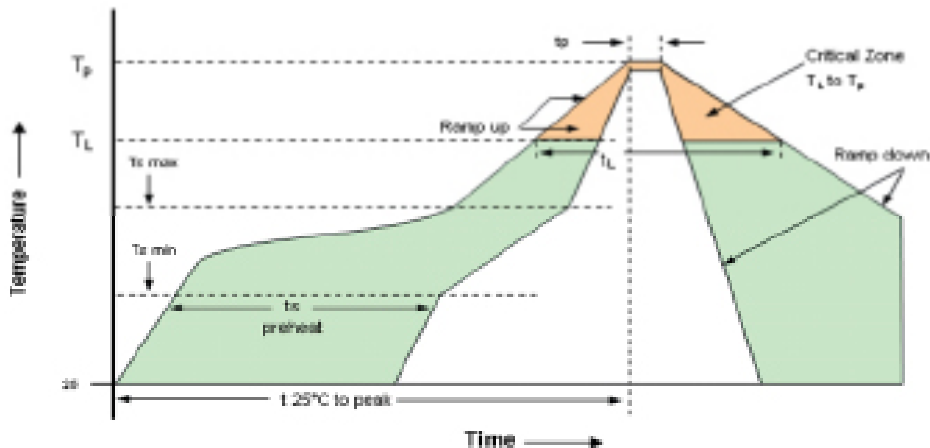

Table 6. Reflow Profile

Parameter	Symbol	Value
PreHeat Time T _{s-min} T _{s-max}	t _s	60 sec Min, 260 sec Max 150°C 200°C
Ramp Up	R _{UP}	3 °C/sec Max
Time Above 217 °C	t _L	60 sec Min, 150 sec Max
Time To Peak Temperature	T _{AMB-P}	480 sec Max
Time at 260 °C	t _p	10 sec Max
Ramp Down	R _{DN}	6 °C/sec Max

Tape and Reel

Table 7 . Tape and Reel Dimensions

Dimension	Tape Dimensions (mm)					Reel Dimensions (mm)								# Per Reel
	W	F	Do	Po	P1	A	B	C	D	N	W1	W2		
VC-820	8	3.5	1.5	4	4	178	2	13	21	60	10	14	1000	

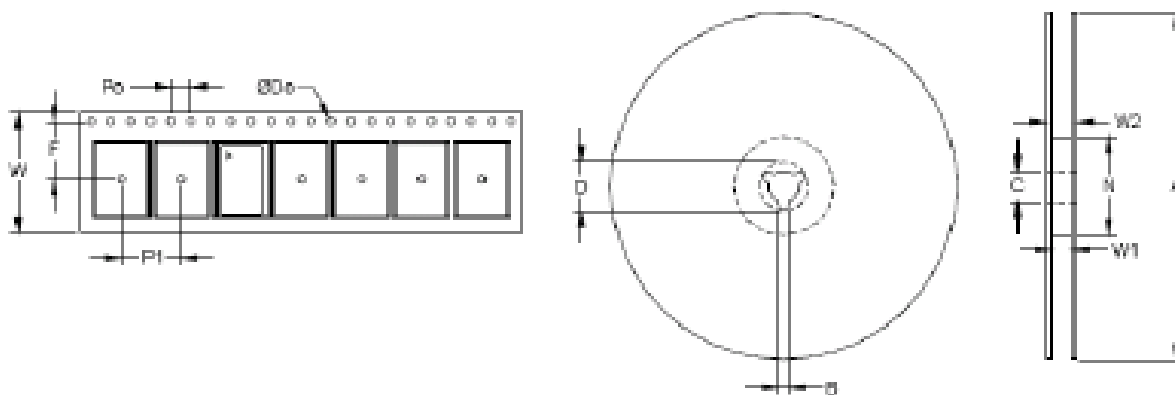

Phase Noise

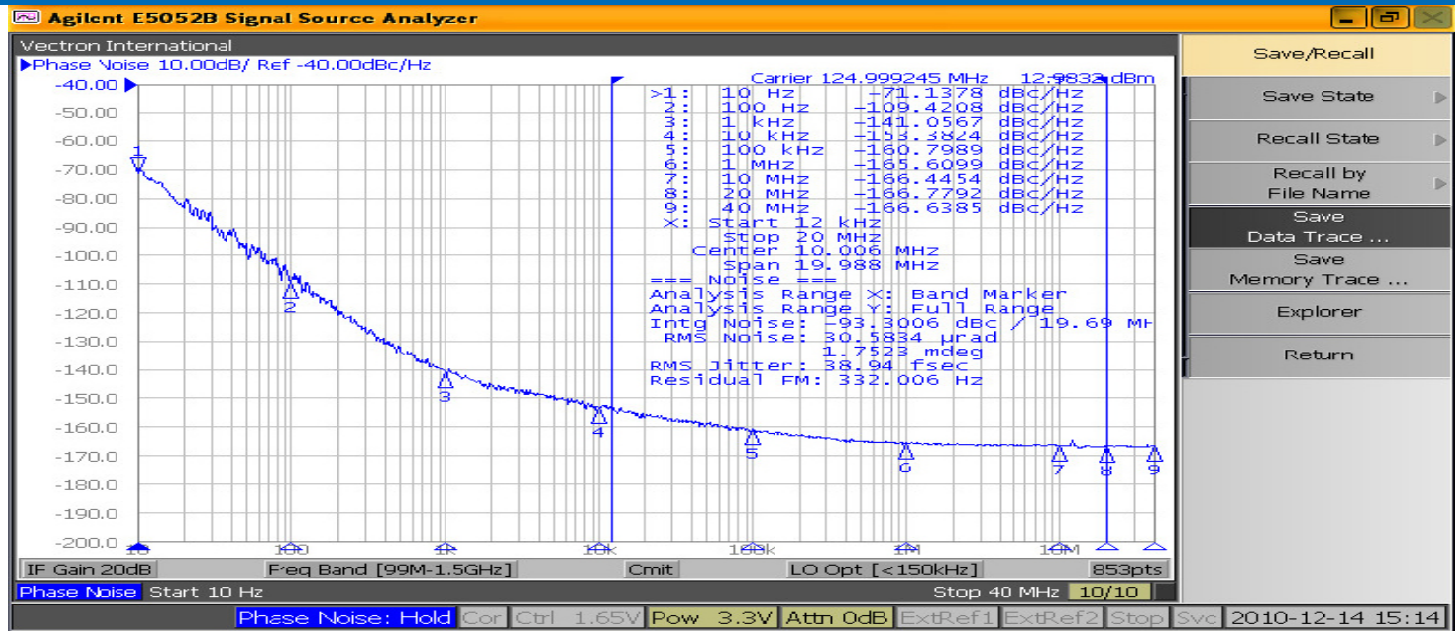

Ordering Information

VC-820- 0010- 114M285000

Product —
 Crystal Oscillator
Package —
 2.5x3.2 Ceramic
Specifications —
 See Table 1

Frequency in MHz

For Additional Information, Please Contact

USA:

Vectron International
 267 Lowell Road
 Hudson, NH 03051
 Tel: 1.888.328.7661
 Fax: 1.888.329.8328

Europe:

Vectron International
 Landstrasse, D-74924
 Neckarbischofsheim, Germany
 Tel: +49 (0) 3328.4784.17
 Fax: +49 (0) 3328.4784.30

Asia:

Vectron International
 1F-2F, No 8 Workshop, No 308 Fenju Road
 WaiGaoQiao Free Trade Zone
 Pudong, Shanghai, China 200131
 Tel: 86.21.5048.0777
 Fax: 86.21.5048.1881

Disclaimer

Vectron International reserves the right to make changes to the product(s) and/or information contained herein without notice. No liability is assumed as a result of their use or application. No rights under any patent accompany the sale of any such product(s) or information.

Rev: 10/22/13

X-ON Electronics

Largest Supplier of Electrical and Electronic Components

Click to view similar products for [Standard Clock Oscillators](#) category:

Click to view products by [Microchip](#) manufacturer:

Other Similar products are found below :

[601252](#) [F335-12](#) [F335-25](#) [F535L-33.333](#) [F535L-50](#) [ASV-20.000MHZ-LR-T](#) [ECS-2018-160-BN-TR](#) [EL13C7-H2F-125.00M](#) [MXO45HS-2C-66.6666MHZ](#) [SiT8209AI-32-33E-125.000000](#) [SM4420TEV-40.0M-T1K](#) [F335-24](#) [F335-40](#) [F535L-10](#) [F535L-12](#) [F535L-16](#) [F535L-24](#) [F535L-27](#) [F535L-48](#) [PE7744DW-100.0M](#) [CSX-750FCC14745600T](#) [ASF1-3.686MHZ-N-K-S](#) [XO57CTECNA3M6864](#) [ECS-2100A-147.4](#) [601251](#) [EP16E7E2H26.000MTR](#) [SIT8918AA-11-33S-16.000000G](#) [XO3003](#) [9120AC-2D2-33E212.500000](#) [9102AI-243N25E100.00000](#) [8208AC-82-18E-25.00000](#) [ASDK2-32.768KHZ-LR-T3](#) [8008AI-72-XXE-24.545454E](#) [8004AC-13-33E-133.33000X](#) [AS-4.9152-16-SMD-TR](#) [ASFL1-48.000MHZ-LC-T](#) [SIT8920AM-31-33E-25.0000](#) [DSC1028DI2-019.2000](#) [9121AC-2C3-25E100.00000](#) [9102AI-233N33E100.00000X](#) [9102AI-233N25E200.00000](#) [9102AI-232H25S125.00000](#) [9102AI-133N25E200.00000](#) [9102AC-283N25E200.00000](#) [9001AC-33-33E1-30.000](#) [XLH536125.000JS4I](#) [3921AI-2CF-33NZ125.000000](#) [5730-1SF](#) [PXA000010](#) [SIT1602BC-83-33E-10.000000Y](#)