

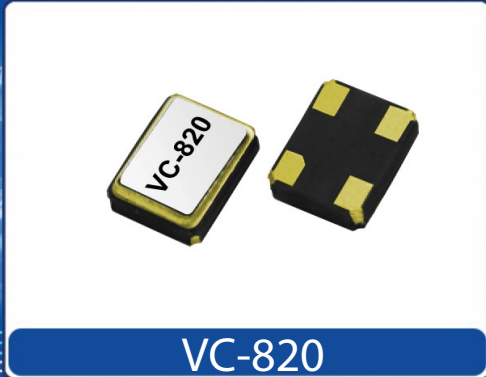

Helping Customers Innovate, Improve & Grow



Description

Vectron's VC-820 Crystal Oscillator (XO) is a quartz stabilized square wave generator with a CMOS output. The VC-820 uses a fundamental or a 3rd overtone crystal, oscillating in a fundamental tone, resulting in very low jitter performance, and a monolithic IC which improves reliability and reduces cost.

Features

- CMOS output XO
- Output Frequencies from 625 kHz to 133.000 MHz
- 3.3 V, 2.5 V and 1.8 V Operation
- Low Jitter Performance
- Output Disable Feature
- Operating Temperature ranging from -55°C to 125°C
- Small Industry Standard Package, 3.2x2.5 mm
- Product is compliant to RoHS directive  and fully compatible with lead free assembly

Applications

- SONET/SDH/DWDM
- Ethernet, GE, SynchE
- Storage Area Networking
- Fiber Channel
- Digital Video
- Broadband Access
- Base Stations, Picocells

Block Diagram

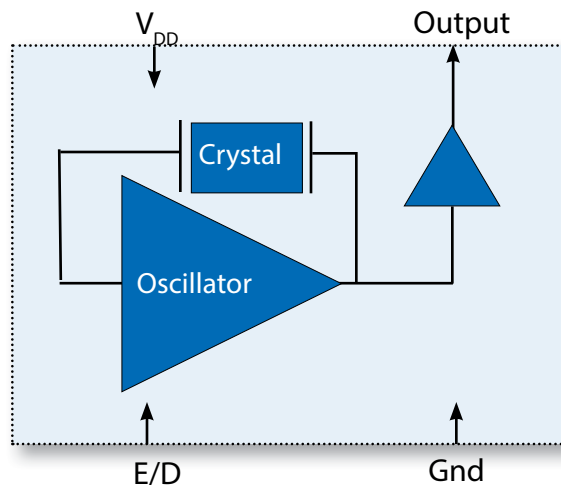

Specifications

Table 1. Electrical Performance, 3.3V Option					
Parameter	Symbol	Min	Typical	Max	Units
Supply Voltage					
Voltage ¹	V_{DD}	3.15	3.3	3.45	V
Maximum Voltage		-0.5		5	V
Current ² ≤20.000MHz 20.000 to 39.999MHz 40.000 to 49.999MHz 50.000 to 79.999MHz 80.000 to 99.999MHz 100.000 to 133.000MHz	I_{DD}			6 7 8 9 10 40	mA
Current, Output Disabled				5	uA
Frequency					
Nominal Frequency ³	f_N	0.625		133.000	MHz
Stability ^{4,8} (Ordering Option)		±20, ±25, ±50, ±100			ppm
Outputs					
Output Logic Levels ² , <40MHz Output Logic High Output Logic Low Output Logic High Drive Output Logic Low Drive	V_{OH} V_{OL} I_{OH} I_{OL}	$0.9*V_{DD}$ 4 4		$0.1*V_{DD}$	V V mA mA
Output Logic Levels ² , 40-99.99MHz Output Logic High Output Logic Low Output Logic High Drive Output Logic Low Drive	V_{OH} V_{OL} I_{OH} I_{OL}	$V_{DD}-0.4$ 4 4		0.4	V V mA mA
Output Logic Levels ² , 100-133.000MHz Output Logic High Output Logic Low Output Logic High Drive Output Logic Low Drive	V_{OH} V_{OL} I_{OH} I_{OL}	2.3 8 8		0.4	V V mA mA
Load	I_{OUT}			15	pF
Output Rise /Fall Time ²	t_R/t_F			4	ns
Duty Cycle ^{2,5}		45	50	55	%
Period Jitter ⁶ RMS Peak-Peak Random Jitter Deterministic Jitter	ϕ_J		2.4 20.2 2.4 0		ps
RMS Jitter, 12k-20MHz, 125MHz	ϕ_J		0.06	0.3	ps
Enable/Disable					
Output Enable/Disable ⁷ Output Enable Output Disable	V_{IH} V_{IL}	$0.7*V_{DD}$		$0.3*V_{DD}$	V V
Disable time	t_D			150	ns
Start-Up Time	t_{SU}			5	ms
Operating Temp (Ordering Option)	T_{OP}	-10/70, -40/85, -40/105, -40/125, -55/105, -55/125			°C

1] The power supply should have by-pass capacitors as close to the supply and to ground as possible, for example 0.1 and 0.01uF.

2] Parameters are tested with the test circuit shown Figure 1.

3] See Standard Frequencies and Ordering Information tables for more specific information.

4] Includes initial accuracy, operating temperature, supply voltage, shock and vibration (not under operation) and aging.

5] Duty Cycle is measured as On Time/Period, see Fig 2.

6] Broadband Period Jitter measured using Wavecrest SIA3300C, 90K samples.

7] The Output is Enabled if the Enable/Disable is left open.

8] Only ±50 and ±100ppm stability options are available for -40/105 °C, -40/125 °C, -55/105 °C and -55/125 °C temperature range.

Specifications

Table 2. Electrical Performance, 2.5V Option

Parameter	Symbol	Min	Typical	Max	Units
Supply Voltage					
Voltage ¹	V_{DD}	2.375	2.5	2.625	V
Maximum Voltage		-0.5		5	V
Current ² ≤20.000MHz 20.000 to 39.999MHz 40.000 to 79.999MHz 80.000 to 99.999MHz 100.000 to 125.000MHz	I_{DD}			4.5 5.5 7 7.5 30	mA
Current, Output Disabled				5	uA
Frequency					
Nominal Frequency ³	f_N	0.625		125.000	MHz
Stability ^{4,8} (Ordering Option)		±20, ±25, ±50, ±100			ppm
Outputs					
Output Logic Levels ^{2,3} , <40MHz Output Logic High Output Logic Low Output Logic High Drive Output Logic Low Drive	V_{OH} V_{OL} I_{OH} I_{OL}	$0.9 \cdot V_{DD}$ 4 4		$0.1 \cdot V_{DD}$	V V mA mA
Output Logic Levels ² , 40-99.99MHz Output Logic High Output Logic Low Output Logic High Drive Output Logic Low Drive	V_{OH} V_{OL} I_{OH} I_{OL}	$V_{DD}-0.4$ 4 4		0.4	V V mA mA
Output Logic Levels ² , 100-125.000MHz Output Logic High Output Logic Low Output Logic High Drive Output Logic Low Drive	V_{OH} V_{OL} I_{OH} I_{OL}	1.65 8 8		0.4	V V mA mA
Load	I_{OUT}			15	pF
Output Rise /Fall Time ²	t_R/t_F			4	ns
Duty Cycle ^{2,5}		45	50	55	%
Period Jitter ⁶ , 125.000MHz RMS Peak-Peak Random Jitter Deterministic Jitter	ϕJ		2.4 20.2 2.4 0		ps
RMS Jitter, 12k-20MHz, 125.000MHz	ϕJ		0.061	0.3	ps
Enable/Disable					
Output Enable/Disable ⁷ Output Enable Output Disable	V_{IH} V_{IL}	$0.7 \cdot V_{DD}$		$0.3 \cdot V_{DD}$	V V
Disable time	t_D			150	ns
Start-Up Time	t_{SU}			5	ms
Operating Temp (Ordering Option)	T_{OP}	-10/70, -40/85, -40/105, -40/125, -55/105, -55/125			°C

1] The power supply should have by-pass capacitors as close to the supply and to ground as possible, for example 0.1 and 0.01uF.

2] Parameters are tested with the test circuit shown Figure 1.

3] See Standard Frequencies and Ordering Information tables for more specific information.

4] Includes initial accuracy, operating temperature, supply voltage, shock and vibration (not under operation) and aging.

5] Duty Cycle is measured as On Time/Period, see Fig 2.

6] Broadband Period Jitter measured using Wavecrest SIA3300C, 90K samples.

7] The Output is Enabled if the Enable/Disable is left open.

8] Only ±50 and ±100ppm stability options are available for -40/105 °C, -40/125 °C, -55/105 °C and -55/125 °C temperature range.

Table 3. Electrical Performance, 1.8V Option

Parameter	Symbol	Min	Typical	Max	Units
Supply					
Voltage ¹	V_{DD}	1.71	1.8	1.89	V
Maximum Voltage		-0.5		3.6	V
Current ² ≤40.000MHz 40.000 to 49.999MHz 50.000 to 79.999MHz 80.000 to 99.999MHz 100.0000 to 125.000MHz	I_{DD}			2.5 3.5 6.5 7 20	mA
Current, Output Disabled				10	uA
Frequency					
Nominal Frequency ³	f_N	0.625		125.000	MHz
Stability ^{4,8} (Ordering Option)		±20, ±25, ±50, ±100			ppm
Outputs					
Output Logic Levels ^{2,3} , <40.000MHz Output Logic High Output Logic Low Output Logic High Drive Output Logic Low Drive	V_{OH} V_{OL} I_{OH} I_{OL}	0.9* V_{DD} 2.8 2.8		0.1* V_{DD}	V V mA mA
Output Logic Levels ^{2,3} , 40.00-125MHz Output Logic High Output Logic Low Output Logic High Drive Output Logic Low Drive	V_{OH} V_{OL} I_{OH} I_{OL}	V_{DD} -0.4 4 4		0.4	V V mA mA
Load	I_{OUT}			15	pF
Output Rise /Fall Time ²	t_R/t_F			5	ns
Duty Cycle ^{2,5}		45	50	55	%
Period Jitter ⁶ RMS Peak-Peak Random Jitter Deterministic Jitter	ϕJ		2.4 20.2 2.4 0		ps
RMS Jitter, 12kHz-20MHz, 62.500MHz	ϕJ		0.4	0.9	ps
Enable/Disable					
Output Enable/Disable ⁷ Output Enable Output Disable	V_{IH} V_{IL}	0.7* V_{DD}		0.3* V_{DD}	V V
Disable time	t_D			150	ns
Start-Up Time	t_{SU}			5	ms
Operating Temp (Ordering Option)	T_{OP}	-10/70, -40/85, -40/105, -40/125, -55/105, -55/125			°C

1] The power supply should have by-pass capacitors as close to the supply and to ground as possible, for example 0.1 and 0.01uF.

2] Parameters are tested with the test circuit shown Figure 1.

3] See Standard Frequencies and Ordering Information tables for more specific information.

4] Includes initial accuracy, operating temperature, supply voltage, shock and vibration (not under operation) and aging.

5] Duty Cycle is measured as On Time/Period, see Fig 2.

6] Broadband Period Jitter measured using Wavecrest SIA3300C, 90K samples.

7] The Output is Enabled if the Enable/Disable is left open.

8] Only ±50 and ±100ppm stability options are available for -40/105 °C, -40/125 °C, -55/105 °C and -55/125 °C temperature range.

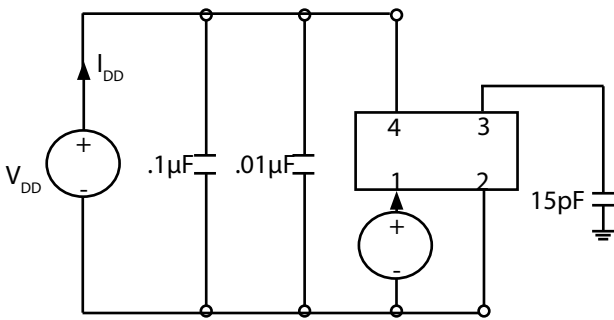

Fig 1: Test Circuit

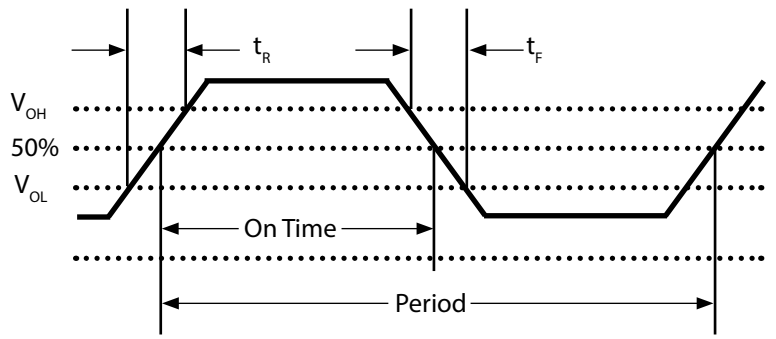
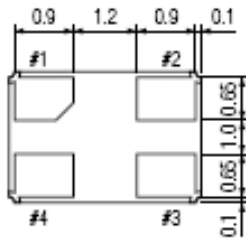
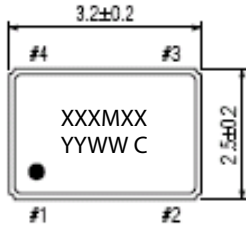

Fig 2: Waveform

Outline Drawing & Pad Layout



Dimensions in mm

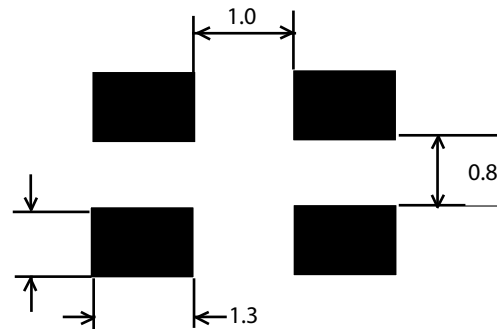

Table 4. Pin Out

Pin	Symbol	Function
1	E/D	Enable Disable
2	GND	Case and Electrical Ground
3	Output	Output
4	V _{DD}	Power Supply Voltage

Table 5. Enable Disable Function

E/D Pin	Output
High	Clock Output
Open	Clock Output
Low	High Impedance

Reliability

Vetron qualification will include aging at various extreme temperatures, shock and vibration, temperature cycling, and IR reflow simulation. The VC-820 family is capable of meeting the following qualification tests:

Table 6. Environmental Compliance

Parameter	Conditions
Mechanical Shock	MIL-STD-883, Method 2002
Mechanical Vibration	MIL-STD-883, Method 2007
Solderability	MIL-STD-883, Method 2003
Gross and Fine Leak	MIL-STD-883, Method 1014
Resistance to Solvents	MIL-STD-883, Method 2015
Moisture Sensitivity Level	MSL 1
Contact Pads	Gold (0.3µm min - 1.µm max) over Nickel
Weight	27 mg

Although ESD protection circuitry has been designed into the VC-820 proper precautions should be taken when handling and mounting. Vectron employs a human body model (HBM) and a charged device model (CDM) for ESD susceptibility testing and design protection evaluation.

Table 7. ESD Ratings

Model	Minimum	Conditions
Human Body Model	1500V	MIL-STD-883, Method 3015
Charged Device Model	1000V	JESD22-C101

Stresses in excess of the absolute maximum ratings can permanently damage the device. Functional operation is not implied at these or any other conditions in excess of conditions represented in the operational sections of this datasheet. Exposure to absolute maximum ratings for extended periods may adversely affect device reliability. Permanent damage is also possible if E/D is applied before V_{DD} .

Table 8. Absolute Maximum Ratings

Parameter	Symbol	Ratings	Unit
Storage Temperature	T_S	-55 to 125	°C
Soldering Temp/Time	T_{LS}	260 / 30	°C / sec

IR Reflow

Solderprofile:

The VC-820 is qualified to meet the JEDEC standard for Pb-Free assembly. The temperatures and time intervals listed are based on the Pb-Free small body requirements. The VC-820 device is hermetically sealed so an aqueous wash is not an issue.

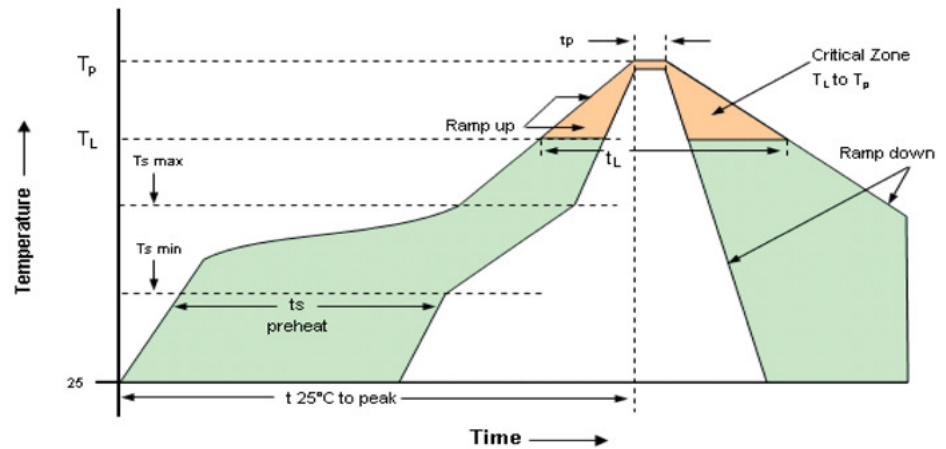

Table 9. Reflow Profile

Parameter	Symbol	Value
PreHeat Time T_S -min T_S -max	t_S	60 sec Min, 260 sec Max 150°C 200°C
Ramp Up	R_{UP}	3 °C/sec Max
Time Above 217 °C	t_L	60 sec Min, 150 sec Max
Time To Peak Temperature	T_{AMB-P}	480 sec Max
Time at 260 °C	t_P	30 sec Max
Ramp Down	R_{DN}	6 °C/sec Max

Tape and Reel

Table 10 . Tape and Reel Dimensions

Tape Dimensions (mm)						Reel Dimensions (mm)							
Dimension	W	F	Do	Po	P1	A	B	C	D	N	W1	W2	# Per Reel
Tolerance	Typ	Typ	Typ	Typ	Typ	Typ	Min	Typ	Min	Min	Typ	Max	
VC-820	8	3.5	1.5	4	4	178	2	13	21	60	10	14	1000

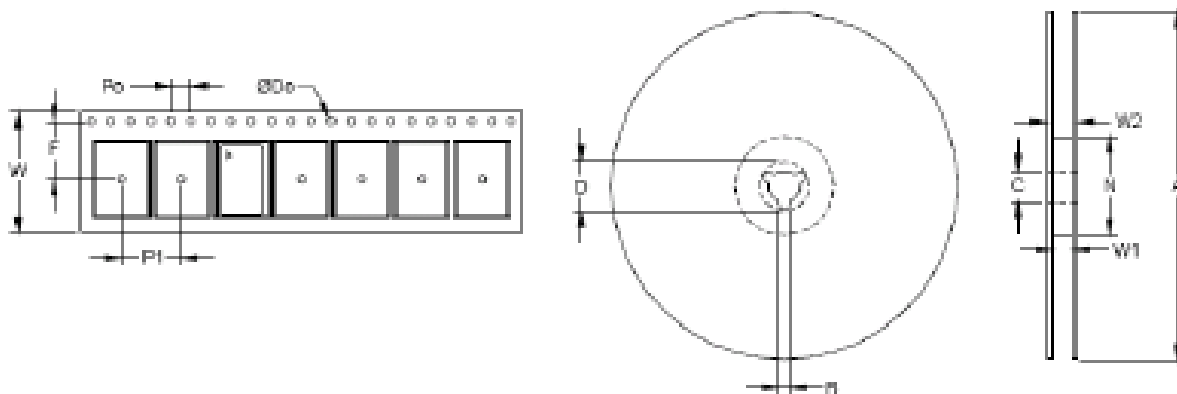
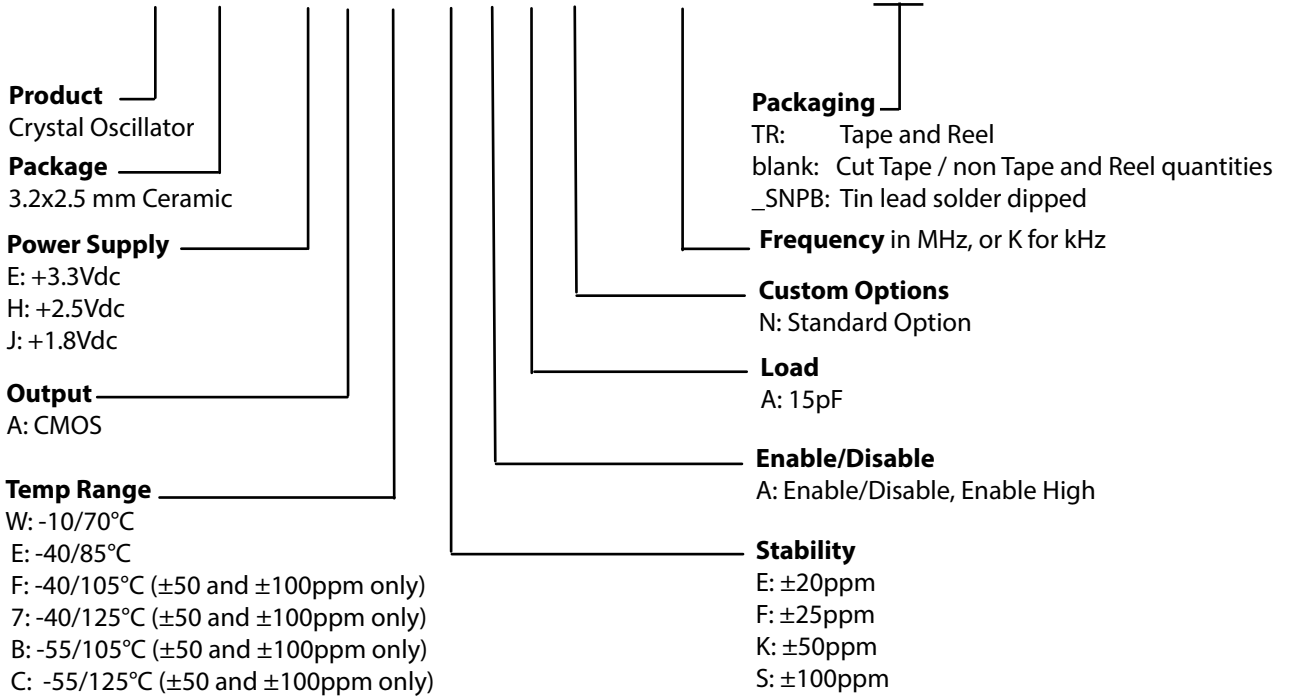

Table 11. Standard Output Frequencies (MHz)

0.032768	0.625000	2.000	4.000	8.000	10.000	10.700	14.31818	16.000
16.384	16.875	18.432	20.000	24.000	24.576	25.000	25.0125	26.000
27.000	28.63630	29.4912	30.000	31.250	31.700	32.000	33.000	33.333000
35.328	40.000	43.675771	48.000	50.000	62.500	64.000	66.666000	75.000
80.000	93.750	100.000	106.250	108.000	114.285	125.000		

Ordering Information

VC-820- E A W- K A A N- xxMxxxxxxxXX



**Note: not all combination of options are available. Other specifications may be available upon request. Please consult with factory.*

Example:

VC-820-EAE-KAAN-25M000000TR	Tape and Reel
VC-820-EAE-KAAN-25M0000000	Cut Tape
VC-820-EAE-KAAN-25M0000000_SNPB	Tin lead solder dipped

Revision History

Revision Date	Approved	Description
January 20, 2015	VN	Included ordering options for -40/105°C, -40/125°C and -55/105°C Operating temperature ranges
August 10, 2018	FB	Update logo and contact information, added SNPB DIP ordering option
March 21, 2019	FB	Update logo and contact information, change to SNPB ordering option
April 30, 2020	FB	Add tape and reel ordering option, updates and corrections as needed

Contact Information

USA:

100 Watts Street
Mt Holly Springs, PA 17065
Tel: 1.717.486.3411
Fax: 1.717.486.5920

Europe:

Landstrasse
74924 Neckarbischofsheim
Germany
Tel: +49 (0) 7268.801.0
Fax: +49 (0) 7268.801.281



Information contained in this publication regarding device applications and the like is provided only for your convenience and may be superseded by updates. It is your responsibility to ensure that your application meets with your specifications. MICROCHIP MAKES NO REPRESENTATION OR WARRANTIES OF ANY KIND WHETHER EXPRESS OR IMPLIED, WRITTEN OR ORAL, STATUTORY OR OTHERWISE, RELATED TO THE INFORMATION INCLUDING, BUT NOT LIMITED TO ITS CONDITION, QUALITY, PERFORMANCE, MERCHANTABILITY OR FITNESS FOR PURPOSE. Microchip disclaims all liability arising from this information and its use. Use of Microchip devices in life support and/or safety applications is entirely at the buyer's risk, and the buyer agrees to defend, indemnify and hold harmless Microchip from any and all damages, claims, suits, or expenses resulting from such use. No licenses are conveyed, implicitly, or otherwise, under any Microchip intellectual property rights unless otherwise stated.

Trademarks

The Microchip and Vectron names and logos are registered trademarks of Microchip Technology Incorporated in the U.S.A. and other countries.

X-ON Electronics

Largest Supplier of Electrical and Electronic Components

Click to view similar products for [Standard Clock Oscillators](#) category:

Click to view products by [Microchip](#) manufacturer:

Other Similar products are found below :

[601252](#) [F335-25](#) [F535L-33.333](#) [F535L-50](#) [NBXHBA019LN1TAG](#) [SiT1602BI-22-33E-50.000000E](#) [SIT8918AA-11-33S-50.000000G](#)
[SM4420TEV-40.0M-T1K](#) [F335-24](#) [F335-40](#) [F535L-10](#) [F535L-12](#) [F535L-24](#) [F535L-27](#) [PE7744DW-100.0M](#) [ASF1-3.686MHZ-N-K-S](#) [ASV-](#)
[4.000MHZ-LCS-T](#) [XLH735025.000JU4I8](#) [XLP725125.000JU6I8](#) [XO57CTECNA3M6864](#) [601251](#) [SiT8503AI-18-33E-0.200000X](#)
[SIT8918AA-11-33S-16.000000G](#) [SIT9122AI2C233E300.000000X](#) [9120AC-2D2-33E212.500000](#) [9102AI-243N25E100.00000](#) [8208AC-82-](#)
[18E-25.00000](#) [8008AI-72-XXE-24.545454E](#) [8004AC-13-33E-133.33000X](#) [AS-4.9152-16-SMD-TR](#) [ASFL1-48.000MHZ-LC-T](#)
[632L3I004M00000](#) [SIT8920AM-31-33E-25.0000](#) [DSC1028DI2-019.2000](#) [9121AC-2C3-25E100.00000](#) [9102AI-233N33E100.00000X](#)
[9102AI-233N25E200.00000](#) [9102AI-232H25S125.00000](#) [9102AI-133N25E200.00000](#) [9102AC-283N25E200.00000](#) [9001AC-33-33E1-30.000](#)
[8103AC-13-33E-12.00000X](#) [3921AI-2CF-33NZ125.000000](#) [5730-1SF](#) [XUN736000.032768I](#) [ASV-25.000MHZ-ECS-50-T](#) [EC3925ETTTS-](#)
[100.000M TR](#) [SIT1602BC-83-33E-10.000000Y](#) [8003AI-12-33S-40.00000Y](#) [1602BI-13-33S-19.200000E](#)