

**VSC8257-01 Datasheet**  
**Quad Channel 1G/10GBASE-KR to SFI Ethernet WIS**  
**PHY with VeriTime™**



---

a  **MICROCHIP** company



**Microsemi Headquarters**

One Enterprise, Aliso Viejo,  
CA 92656 USA

Within the USA: +1 (800) 713-4113

Outside the USA: +1 (949) 380-6100

Sales: +1 (949) 380-6136

Fax: +1 (949) 215-4996

Email: [sales.support@microsemi.com](mailto:sales.support@microsemi.com)

[www.microsemi.com](http://www.microsemi.com)

©2017–2018 Microsemi, a wholly owned subsidiary of Microchip Technology Inc. All rights reserved. Microsemi and the Microsemi logo are registered trademarks of Microsemi Corporation. All other trademarks and service marks are the property of their respective owners.

Microsemi makes no warranty, representation, or guarantee regarding the information contained herein or the suitability of its products and services for any particular purpose, nor does Microsemi assume any liability whatsoever arising out of the application or use of any product or circuit. The products sold hereunder and any other products sold by Microsemi have been subject to limited testing and should not be used in conjunction with mission-critical equipment or applications. Any performance specifications are believed to be reliable but are not verified, and Buyer must conduct and complete all performance and other testing of the products, alone and together with, or installed in, any end-products. Buyer shall not rely on any data and performance specifications or parameters provided by Microsemi. It is the Buyer's responsibility to independently determine suitability of any products and to test and verify the same. The information provided by Microsemi hereunder is provided "as is, where is" and with all faults, and the entire risk associated with such information is entirely with the Buyer. Microsemi does not grant, explicitly or implicitly, to any party any patent rights, licenses, or any other IP rights, whether with regard to such information itself or anything described by such information. Information provided in this document is proprietary to Microsemi, and Microsemi reserves the right to make any changes to the information in this document or to any products and services at any time without notice.

**About Microsemi**

Microsemi, a wholly owned subsidiary of Microchip Technology Inc. (Nasdaq: MCHP), offers a comprehensive portfolio of semiconductor and system solutions for aerospace & defense, communications, data center and industrial markets. Products include high-performance and radiation-hardened analog mixed-signal integrated circuits, FPGAs, SoCs and ASICs; power management products; timing and synchronization devices and precise time solutions, setting the world's standard for time; voice processing devices; RF solutions; discrete components; enterprise storage and communication solutions, security technologies and scalable anti-tamper products; Ethernet solutions; Power-over-Ethernet ICs and midspans; as well as custom design capabilities and services. Learn more at [www.microsemi.com](http://www.microsemi.com).

# Contents

<b>1</b>	<b>Revision History</b>	<b>1</b>
1.1	Revision 4.1	1
1.2	Revision 4.0	1
1.3	Revision 2.1	1
1.4	Revision 2.0	1
<b>2</b>	<b>Overview</b>	<b>2</b>
2.1	Highlights	2
2.2	Interfaces	3
2.3	Features	4
2.4	Applications	5
2.4.1	IEEE 1588v2 One-Step End-to-End Transparent Clock	5
2.4.2	IEEE 1588v2 Transparent Clock and Boundary Clock	6
<b>3</b>	<b>Functional Descriptions</b>	<b>8</b>
3.1	Data Path Overview	8
3.1.1	Ingress and Egress Operation: Repeater (or Pass-Through) Mode	8
3.1.2	Ingress Operation: Ethernet Mode	9
3.1.3	Egress Operation: Ethernet Mode	9
3.2	Physical Media Attachment (PMA)	10
3.2.1	Reference Clock	10
3.2.2	VScope™ Input Signal Monitoring Integrated Circuit	10
3.2.3	10GBASE-KR	10
3.3	Wide Area Network Interface Sublayer (WIS)	12
3.3.1	Operation	12
3.3.2	Section Overhead	15
3.3.3	Frame Alignment (A1, A2)	16
3.3.4	Loss of Signal (LOS)	19
3.3.5	Loss of Optical Carrier (LOPC)	20
3.3.6	Severely Errored Frame (SEF)	20
3.3.7	Loss of Frame (LOF)	20
3.3.8	Section Trace (J0)	20
3.3.9	Reserved for Section Growth (Z0)	21
3.3.10	Scrambling/Descrambling	21
3.3.11	Section Error Monitoring (B1)	21
3.3.12	Section Orderwire (E1)	22
3.3.13	Section User Channel (F1)	22
3.3.14	Section Data Communication Channel (DCC-S)	22
3.3.15	Reserved, National, and Unused Octets	22
3.3.16	Line Overhead	22
3.3.17	SPE Pointer	26
3.3.18	Path Overhead	30
3.3.19	Overhead Serial Interfaces	38
3.3.20	Pattern Generator and Checker	41
3.4	10G Physical Coding Sublayer (64b/66b PCS)	41
3.4.1	PCS Standard Test Modes	42
3.5	1G Physical Coding Sublayer	43
3.6	IEEE 1588 Block Operation	43
3.6.1	IEEE 1588 Block	44
3.6.2	IEEE 1588v2 One-Step End-to-End Transparent Clock	46
3.6.3	IEEE 1588v2 Transparent Clock and Boundary Clock	46

3.6.4	Enhancing IEEE 1588 Accuracy for CE Switches and MACs	47
3.6.5	Supporting One-Step Boundary Clock/Ordinary Clock	47
3.6.6	Supporting Two-Step Boundary Clock/Ordinary Clock	49
3.6.7	Supporting One-Step End-to-End Transparent Clock	51
3.6.8	Supporting One-Step Peer-to-Peer Transparent Clock	54
3.6.9	Supporting Two-Step Transparent Clock	58
3.6.10	Calculating OAM Delay Measurements	60
3.6.11	Supporting Y.1731 One-Way Delay Measurements	60
3.6.12	Supporting Y.1731 Two-Way Delay Measurements	61
3.6.13	Device Synchronization for IEEE 1588 Support	64
3.6.14	Time Stamp Update Block	65
3.6.15	Analyzer	68
3.6.16	Time Stamp Processor	89
3.6.17	Time Stamp FIFO	90
3.6.18	Rewriter	92
3.6.19	Local Time Counter	93
3.6.20	Serial Time of Day	95
3.6.21	Programmable Offset for LTC Load Register	97
3.6.22	Adjustment of LTC Counter	97
3.6.23	Pulse per Second Output	98
3.6.24	Accuracy and Resolution	99
3.6.25	Loopbacks	99
3.6.26	Accessing 1588 IP Registers	100
3.7	Flow Control Buffers	100
3.8	Rate Compensating Buffers	100
3.9	Loopback	100
3.10	Cross Connect	101
3.11	Host-Side Interface	101
3.12	Clocking	101
3.12.1	Synchronous Ethernet Support	102
3.13	Operating Modes	104
3.13.1	10G LAN with 1588	104
3.13.2	10G WAN with 1588	104
3.13.3	1 GbE with 1588 and MACs	104
3.14	Management Interfaces	105
3.14.1	MDIO Interface	105
3.14.2	SPI Slave Interface	106
3.14.3	Two-Wire Serial (Slave) Interface	109
3.14.4	Two-Wire Serial (Master) Interface	111
3.14.5	Push Out SPI Master Interface	112
3.14.6	JTAG	112
3.14.7	General Purpose I/O	113
<b>4</b>	<b>Registers</b>	<b>118</b>
<b>5</b>	<b>Electrical Specifications</b>	<b>119</b>
5.1	DC Characteristics	119
5.1.1	Low-Speed Inputs and Outputs	119
5.1.2	Reference Clock	120
5.2	AC Characteristics	120
5.2.1	Receiver Specifications	120
5.2.2	Transmitter Specifications	122
5.2.3	Timing and Reference Clock	125
5.2.4	Two-Wire Serial (Slave) Interface	127
5.2.5	MDIO Interface	128
5.2.6	Synchronous Time-of-Day Load/Save Timing	129
5.2.7	SPI Slave Interface	129

5.3	Operating Conditions .....	130
5.4	Stress Ratings .....	131
<b>6</b>	<b>Pin Descriptions .....</b>	<b>133</b>
6.1	Pin Diagram .....	133
6.2	Pins by Function .....	133
<b>7</b>	<b>Package Information .....</b>	<b>143</b>
7.1	Package Drawing .....	143
7.2	Thermal Specifications .....	144
7.3	Moisture Sensitivity .....	145
<b>8</b>	<b>Design Considerations .....</b>	<b>146</b>
8.1	SPI bus speeds .....	146
8.2	Device clocking .....	146
8.3	10GBASE-KR autonegotiation and link training .....	146
8.4	Low-power mode and SerDes calibration .....	146
8.5	Low power mode with failover switching .....	146
8.6	Flow control with failover switching .....	146
8.7	GPIO as TOSI .....	146
8.8	Limited 1G status reporting .....	146
8.9	1G mode operation .....	147
8.10	Loopbacks in 10G WAN mode .....	147
8.11	Timestamp errors due to IEEE 1588 reference clock interruption .....	147
<b>9</b>	<b>Ordering Information .....</b>	<b>148</b>

# Figures

Figure 1	Block Diagram	4
Figure 2	SFP+ Transceiver	5
Figure 3	Backplane Equalization Application	5
Figure 4	Transparent Clock Line Card Application	6
Figure 5	Boundary Clock Line Card Application	7
Figure 6	10GBASE-KR Output Driver	11
Figure 7	10GBASE-KR Test Pattern	12
Figure 8	WIS Transmit and Receive Functions	13
Figure 9	eWIS Frame Structure	14
Figure 10	STS-192c/STM-64 Section and Line Overhead in the WIS	14
Figure 11	STS-192c/STM-64 Path Overhead in the WIS	15
Figure 12	Synchronization State Diagram	17
Figure 13	Secondary SYNC State Diagram	19
Figure 14	Pointer Interpretation States Diagram	29
Figure 15	TOSI Timing	38
Figure 16	ROSI Timing	41
Figure 17	PCS Block Diagram	42
Figure 18	IEEE 1588 Architecture	44
Figure 19	IEEE 1588 Block Diagram	45
Figure 20	IEEE 1588 Transparent Clock and Boundary Clock Line Card Application	46
Figure 21	One-Step End-to-End Boundary Clock	48
Figure 22	Two-Step End-to-End Boundary Clock	50
Figure 23	One-Step End-to-End Transparent Clock Mode A	52
Figure 24	One-Step End-to-End Transparent Clock Mode B	53
Figure 25	Delay Measurements	54
Figure 26	One-Step Peer-to-Peer Transparent Clock Mode B	58
Figure 27	Two-Step End-to-End Transparent Clock	59
Figure 28	Y.1731 1DM PDU Format	60
Figure 29	Y.1731 One-Way Delay	61
Figure 30	Y.1731 DMM PDU Format	62
Figure 31	Y.1731 Two-Way Delay	63
Figure 32	RFC6374 DMM/DMR OAM PDU Format	64
Figure 33	Draft-bhh DMM/DMR/1DM OAM PDU Formats	64
Figure 34	PTP Packet Encapsulations	66
Figure 35	OAM Packet Encapsulations	66
Figure 36	TSU Block Diagram	67
Figure 37	Analyzer Block Diagram	69
Figure 38	Type II Ethernet Basic Frame Format	71
Figure 39	Ethernet Frame with SNAP	71
Figure 40	Ethernet Frame with VLAN Tag and SNAP	72
Figure 41	Ethernet Frame with VLAN Tags and SNAP	72
Figure 42	PBB Ethernet Frame Format (No B-Tag)	72
Figure 43	PBB Ethernet Frame Format (1 B-Tag)	72
Figure 44	MPLS Label Format	75
Figure 45	MPLS Label Stack within an Ethernet Frame	75
Figure 46	MPLS Labels and Control Word	75
Figure 47	IPv4 with UDP	77
Figure 48	IPv6 with UDP	78
Figure 49	ACH Header Format	78
Figure 50	ACH Header with Protocol ID Field	78
Figure 51	IPSec Header Format	79
Figure 52	IPv6 with UDP and IPSec	79
Figure 53	PTP Frame Layout	82
Figure 54	OAM 1DM Frame Header Format	82

Figure 55	OAM DMM Frame Header Format	83
Figure 56	OAM DMR Frame Header Format	83
Figure 57	RFC6374 DMM/DMR OAM PDU Format	83
Figure 58	G8113.1/draft-bhh DMM/DMR/1DM OAM PDU Format	84
Figure 59	Serial Time Stamp/Frame Signature Output	92
Figure 60	Preamble Reduction in Rewriter	93
Figure 61	Local Time Counter Load/Save Timing	94
Figure 62	Standard PPS and 1PPS with TOD Timing Relationship	95
Figure 63	ToD Octet Waveform	96
Figure 64	Host-Side and Line-Side Loopbacks	101
Figure 65	Port Timing Architecture	102
Figure 66	Per-Port Clock Outputs	103
Figure 67	10G LAN with 1588	104
Figure 68	10G WAN with 1588	104
Figure 69	1 GbE with 1588 and MACs	105
Figure 70	SPI Single Register Read	107
Figure 71	SPI Multiple Register Reads	108
Figure 72	SPI Multiple Register Writes	108
Figure 73	SPI Read Following Write	108
Figure 74	SPI Write Following Read	108
Figure 75	SPI Slave Default Mode	109
Figure 76	SPI Slave Fast Mode	109
Figure 77	Two-Wire Serial Bus Reset Sequence	110
Figure 78	Two-Wire Serial Slave Register Address Format	110
Figure 79	Two-Wire Serial Write Instruction	111
Figure 80	Two-Wire Serial Read Instruction	111
Figure 81	GPIO Block Diagram	114
Figure 82	Interrupt Scheme	117
Figure 83	SFI Datacom Sinusoidal Jitter Tolerance	122
Figure 84	SFI Transmit Differential Output Compliance Mask	124
Figure 85	LREFCK/HREFCLK to Data Output Jitter Transfer	126
Figure 86	Two-Wire Serial Interface Timing	127
Figure 87	Timing with MDIO Sourced by STA	128
Figure 88	Timing with MDIO Sourced by MMD	128
Figure 89	Load/Save AC Timing	129
Figure 90	SPI Interface Timing	130
Figure 91	3-Pin Push-Out SPI Timing	130
Figure 92	Pin Diagram	133
Figure 93	VSC8257-01 Package	144

# Tables

Table 1	Repeater (or Pass-through) Mode Interface Data Rates	9
Table 2	Ethernet Mode Interface Data Rates	9
Table 3	Selecting LREFCK Frequency	10
Table 4	Section Overhead Functions and Recommended Values	15
Table 5	Framing Parameter Description and Values	17
Table 6	Line Overhead Octets	22
Table 7	K2 Encoding	25
Table 8	SONET/SDH Pointer Mode Difference	27
Table 9	16-bit Designations within the Payload Pointer	27
Table 10	H1/H2 Pointer Types	28
Table 11	Concatenation Types	28
Table 12	Pointer Interpreter State Transitions	29
Table 13	STS Path Overhead Octets	30
Table 14	Path Status (G1) Byte for RDI-P Mode	32
Table 15	Path Status (G1) Byte for ERDI-P Mode	33
Table 16	RDI-P and ERDI-P Bit Settings and Interpretations	33
Table 17	PMTICK Counters	35
Table 18	Defects and Anomalies	36
Table 19	TOSI/ROSI Addresses	39
Table 20	Flows Per Engine Type	70
Table 21	Ethernet Comparator: Next Protocol	70
Table 22	Comparator ID Codes	71
Table 23	Ethernet Comparator (Next Protocol)	72
Table 24	Ethernet Comparator (Flow)	73
Table 25	MPLS Comparator: Next Word	75
Table 26	Next MPLS Comparator	76
Table 27	MPLS Comparator: Per-Flow	76
Table 28	MPLS Range_Upper/Lower Label Map	76
Table 29	Next-Protocol Registers in OAM-Version of MPLS Block	77
Table 30	Comparator Field Summary	79
Table 31	IP/ACH Next-Protocol Comparison	80
Table 32	IP/ACH Comparator Flow Verification Registers	81
Table 33	PTP Comparison	84
Table 34	PTP Comparison: Common Controls	86
Table 35	PTP Comparison: Additions for OAM-Optimized Engine	86
Table 36	Frame Signature Byte Mapping	87
Table 37	Frame Signature Address Source	87
Table 38	LTC Time Load/Save Options	96
Table 39	Output Pulse Frequencies	98
Table 40	Line-Side Loopbacks	100
Table 41	Host-Side Loopbacks	100
Table 42	MDIO Port Addresses Per Channel	106
Table 43	SPI Slave Instruction Bit Sequence	107
Table 44	JTAG Instructions and Register Codes	112
Table 45	Recommended GPIO Configurations	114
Table 46	LVTTTL Input and Push/Pull Output DC Characteristics	119
Table 47	LVTTLOD Input and Open-Drain Output DC Characteristics	119
Table 48	Reference Clock DC Characteristics	120
Table 49	Host- and Line-Side 10G Receiver Input (SFI Point D)	120
Table 50	Host- and Line-Side 10G Receiver Input (SFI Point C")	121
Table 51	Host- and Line-Side SONET 10G Input Jitter	122
Table 52	Host- and Line-Side 1.25 Gbps SFI Input	122
Table 53	Host- and Line-Side 10G Transmitter Output (SFI Point A)	123
Table 54	Host- and Line-Side 10G Transmitter Output (SFI Point B)	123



Table 55	Transmitter SFP+ Direct Attach Copper Output AC Characteristics . . . . .	124
Table 56	10 Gbps Transmitter 10GBASE-KR AC Characteristics . . . . .	124
Table 57	Host- and Line-Side Optical 10G Output Jitter . . . . .	125
Table 58	Host- and Line-Side 1.25 Gbps SFI Output . . . . .	125
Table 59	Reference Clock AC Characteristics . . . . .	125
Table 60	Two-Wire Serial Interface AC Characteristics . . . . .	127
Table 61	MDIO Interface AC Characteristics . . . . .	128
Table 62	Clock Output AC Characteristics . . . . .	128
Table 63	Load/Save Setup and Hold Timing AC Characteristics . . . . .	129
Table 64	SPI Slave Interface AC Characteristics . . . . .	129
Table 65	3-Pin Push-Out SPI AC Characteristics . . . . .	130
Table 66	Recommended Operating Conditions . . . . .	131
Table 67	Stress Ratings . . . . .	131
Table 68	Thermal Resistances . . . . .	145
Table 69	Ordering Information . . . . .	148

# 1 Revision History

---

This section describes the changes that were implemented in this document. The changes are listed by revision, starting with the most current publication.

## 1.1 Revision 4.1

Revision 4.1 was published in September 2018. In revision 4.1 of this document, the registers were attached. For more information, see [Registers](#), page 118.

## 1.2 Revision 4.0

Revision 4.0 was published in February 2018. The following is a summary of the changes in revision 4.0 of this document.

- The framing parameter description and values table was updated. For more information, see [Table 5](#), page 17
- Section overhead functions and recommended values were updated. For more information, see [Table 4](#), page 15.
- Line overhead octets table was updated. For more information, see [Table 6](#), page 22.
- STS path overhead octets functions were updated. For more information, see [Table 13](#), page 30.
- TOSI/ROSI addresses were updated. For more information, see [Table 19](#), page 39.
- Cross connect information was updated to accurately reflect device functionality. For more information, see [Cross Connect](#), page 101.
- Host- and line-side 10G receiver input characteristics were updated. For more information, see [Table 49](#), page 120 and [Table 50](#), page 121.
- Host- and line-side 10G transmitter output characteristics were updated. For more information, see [Table 53](#), page 123 and [Table 54](#), page 123.
- 10 Gbps transmitter 10GBASE-KR AC characteristics were updated. For more information, see [Table 56](#), page 124.
- Host- and line-side optical 10G output jitter specifications were updated. For more information, see [Table 57](#), page 125.
- Recommended operating conditions and stress ratings were updated. For more information, see [Table 66](#), page 131 and [Table 67](#), page 131.

## 1.3 Revision 2.1

Revision 2.1 was published in January 2018. The following is a summary of the changes in revision 2.1 of this document.

- The two-wire serial slave interface register address illustrations and 24-bit addressing scheme details were updated.
- DC characteristics for low-speed inputs and outputs were updated.
- Receiver and transmitter AC characteristics were updated.
- Reference clock AC characteristics were updated.
- The SPI interface timing diagram was updated.
- Pin descriptions were updated to correctly reflect device functionality.

## 1.4 Revision 2.0

Revision 2.0 was published in September 2017. It was the first publication of the document.

## 2 Overview

The VSC8257-01 device is part of Microsemi's SynchroPHY™ product family. It is a four channel 1G/10G serial-to-serial Ethernet PHY featuring Microsemi's VeriTime™ (IEEE 1588v2) precision network timing technology. It also supports dual-sided 10GBASE-KR functionality including auto-negotiation and training in a small form factor, low-power FCBGA ideal for a wide array of board-level signal integrity designs and system-level IEEE standard compliant (intelligent) Ethernet connectivity.

VeriTime™ is Microsemi's patent-pending timing technology that delivers the industry's most accurate IEEE 1588v2 timing implementation. It is the only IEEE 1588v2 solution to be validated by major OEMs in real-world tests and adopted as the preferred low-cost upgrade for meeting emerging requirements in 4G/LTE-Advanced (LTE-A). With its integration of VeriTime, VSC8257-01 delivers the quickest, lowest cost method of implementing the network timing accuracy that is critical in maintaining existing service levels as provider architectures migrate from TDM to packet-based technologies. The VSC8257-01 device supports both 1-step and 2-step PTP frames for ordinary clock, boundary clock, and transparent clock modes of operation, along with complete Y.1731 OAM performance monitoring capabilities.

The VSC8257-01 device provides a complete suite of on-chip instrumentation including built-in self-test (BIST) functions, line-side and client-side circuit loopbacks, pattern generation, and error detection. Its highly flexible clocking options support LAN and WAN operation using a single 156.25 MHz reference clock rate. Synchronous Ethernet (SyncE) and failover switching for protection routing are also supported.

The VSC8257-01 device delivers excellent jitter attenuation with low power. It is well-suited for SFP+ based optical modules and direct-attach copper cabling as well as challenging backplane interface applications. As a KR repeater it supports 10 GbE LAN, 10 Gb WAN, 40 GbE (4 x 10G), as well as 1 Gb Ethernet.

### 2.1 Highlights

The following standards are supported by the device:

- IEEE Standard 1588v2 (IEEE 1588-2008, Version 2), Precision Clock Synchronization Protocol for Networked Measurement and Control Systems
- ITU Recommendation G.8013/Y.1731, 2013, OAM Functions and Mechanisms for Ethernet-based Networks
- IEEE Standard 802.3ae-2002, Telecommunications and Information Exchange between Local and Metropolitan Area Networks, 10 Gbps Ethernet over fiber for LAN (10GBASE-SR, -LR, -ER, -LX4) and WAN (10GBASE-SW, -LW, and -EW)
- IEEE Standard 802.3ap-2007, Backplane Ethernet (1 and 10 Gbps over printed circuit boards)
- SFF-INF-8074i MSA for 1GbE SFP, Revision 1.0, 2001
- SFF-INF-8077i MSA for XFP, 2005, Specification for 10 Gbps Small Form Factor 10G Pluggable (XFP) Module supporting SONET OC-192 and G.709 (OTU-2), and 10 Gbps Ethernet
- SFF-8431 MSA Specification for SFP+, 2009, High- and Low-speed electrical and management interface specifications for enhanced Small Form Factor Pluggable modules and hosts
- ITU-T G.8261/Y.1361, 2013, Timing and Synchronization Aspects in Packet Networks, Synchronous Ethernet (SyncE)
- ITU-T G.8262/Y.1362, 2012, Timing Characteristics of a Synchronous Ethernet (SyncE) Slave Clock

Data rates supported include:

- Ethernet LAN 10.3125 Gbps, Ethernet WAN 9.95328 Gbps, and Ethernet 1.25 Gbps for line side and 10.3125 Gbps and 1.25 Gbps for host side
- OTN OTU2 (10.709 Gbps), OTU1e (11.049 Gbps), and OTU2e (11.095 Gbps) in repeater mode only (each host side and line side)
- Support for SFP+ I/O and auto-negotiation and training for 10GBASE-KR (IEEE 802.3-2012) backplanes

## 2.2 Interfaces

The VSC8257-01 device provides multiple types of interfaces supporting IEEE 802.3ae, IEEE 1588v2, and IEEE 802.3ap with hardware-based 10GBASE-KR auto-negotiation and training.

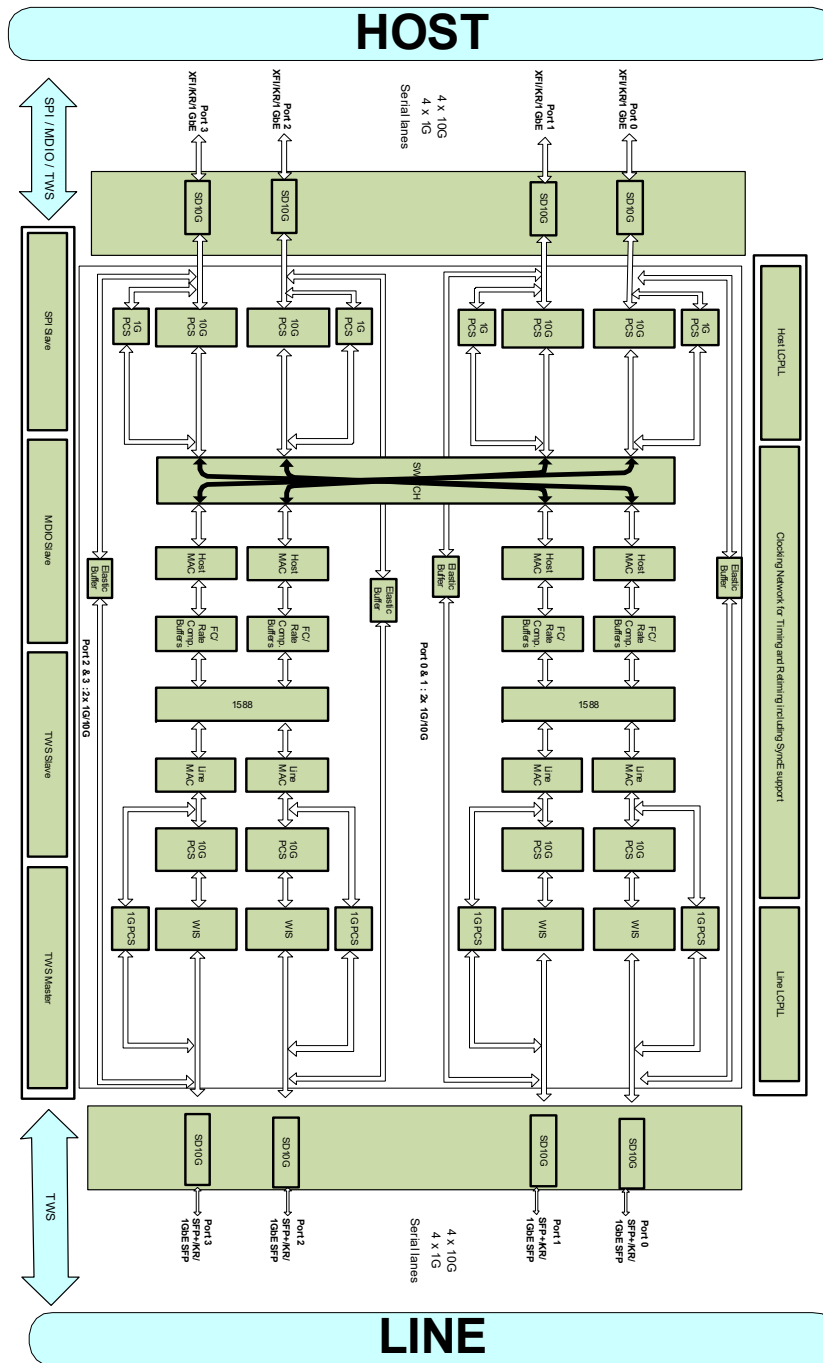
The device meets the 1 GbE SFP and SFP+ SR/LR/ER/ZR host requirements in accordance with the SFF MSA specifications and compensates for optical impairments in SFP+ applications and degradations of the PCB.

The high-speed serial input receiver compensates for loss of optical and copper media performance or margin due to inter-symbol interference (ISI). The high-speed serial transmit output features a 3-tap FIR filter output buffer fully compliant with the 10GBASE-KR standard to provide full 10GBASE-KR support, including 10GBASE-KR state machine, for auto-negotiation and link optimization. The transmit path incorporates a multtap output driver to provide flexibility to meet the demanding 10GBASE-KR (IEEE 802.3ap) Tx output launch requirements.

The serial ports support 1.25 Gbps and 10 Gbps modes. Each channel consists of a receiver (Rx) and a transmitter (Tx) subsection. Programmable reference clock inputs (HREFCK, LREFCK, and SREFCK) support the modes along with clock and data recovery (CDR) in the Rx and Tx subsections of all channels. Each channel of the device can be in a different mode within the limitations of the available reference clocks, while ensuring the Rx and Tx subsections within a channel are in the same mode.

The following illustration shows a high-level block diagram.

Figure 1 • Block Diagram



## 2.3 Features

The main features of the VSC8257-01 device include:

- Support for IEEE 1588v2/1731 OAM precision timing at 1G and 10G
- Compliant with IEEE 802.3ae and SFF-8431 electrical (SFI) specifications
- Support for 9.95 Gbps WAN, 10.3125 Gbps LAN, and 1.25 Gbps Ethernet
- Support for standard SFP+ applications
- Support for 10GBASE-KR (IEEE 802.3ap) for 10G backplanes

- Support for ITU-T recommendation G.709 (OTN) OTU2, OTU1e, and OTU2e line rates in repeater mode only (also known as pass-through mode)
- Adaptive equalization receiver and programmable multistap transmitter pre-emphasis
- Support for Extended WAN interface sublayer (eWIS)
- SPI (preferred), MDIO, and two-wire serial slave management interfaces
- Failover switching for protection routing (non-hitless switching)
- VScope™ input signal monitoring integrated circuitry
- Host-side and line-side loopbacks with BIST functions
- I/O programmability for each channel: invert, amplitude, slew, pre-emphasis, and equalization
- Optional forward error correction (FEC)
- Flexible clocking options that enable Layer 1 support for Synchronous Ethernet
- Passive copper cable support for lowest connectivity cost

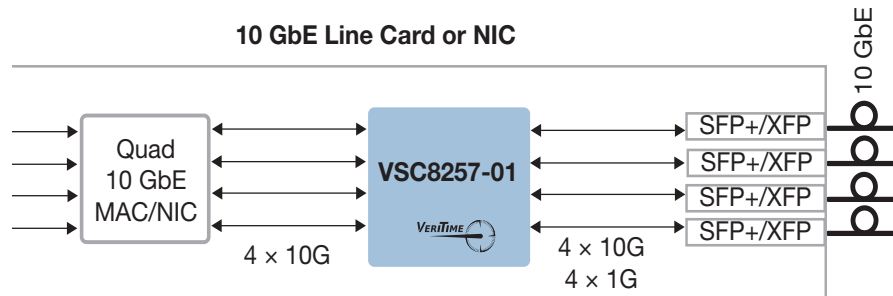
## 2.4 Applications

Target applications for the VSC8257-01 device include switching, IP edge router connectivity, rack mount connectivity through backplane, fiber and copper cable connectivity, and standalone server access (in LAN on motherboard designs or separate network adapters).

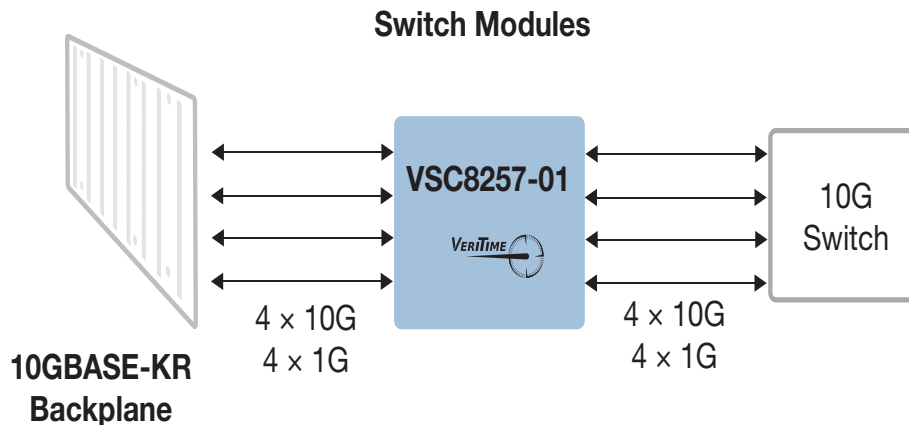
- Multi-port serial-to-serial signal conditioning with cross-connect
- 10GBASE-KR-compliant backplane transceivers
- Networks requiring high-accuracy time synchronization
- Multi-port XFI/10GBASE-KR to SFI/SFP+ 10 GbE switch cards, router cards, and network adapters

The following figures illustrate various device applications.

**Figure 2 • SFP+ Transceiver**



**Figure 3 • Backplane Equalization Application**



### 2.4.1 IEEE 1588v2 One-Step End-to-End Transparent Clock

The time stamp block is located in PHYs and MACs with integrated PHYs that are placed on line cards. If Microsemi 1588 PHYs are used on all ports that support IEEE 1588 one-step end-to-end transparent clocks, the rest of the system does not need to be 1588-aware, and there is no CPU maintenance needed once the system is set up.

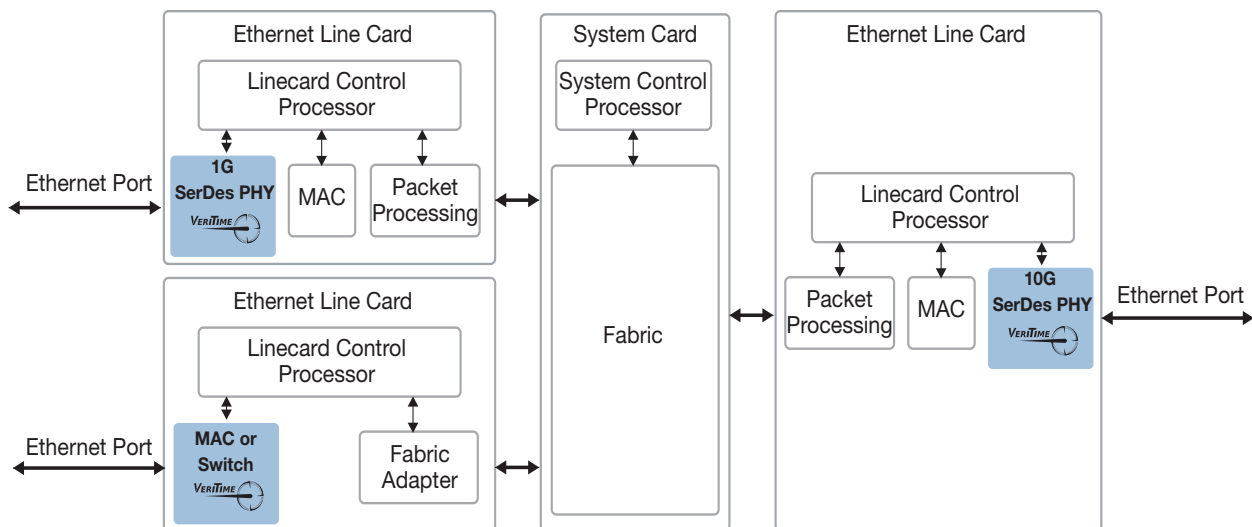
As all the PHYs in a system can be configured the same way, the system supports failover of 1588 masters without any CPU intervention.

This solution works for both blade systems and pizza boxes, where the devices placed on the system side of the PHYs don't need to be 1588-aware. This allows an easy migration path for systems that do not support IEEE 1588, as this feature can be added by replacing existing PHYs with Microsemi 1588 PHYs on all ports.

The requirements for the rest of the system are as follows:

- Delivery of a synchronous global timetick clock (or reference clock) to ensure that the “local time” for all PHYs in the system progresses at the same rate.
- Delivery of a global timetick load to synchronize the local time counters in each PHY.
- CPU access to each PHY to set up the required configuration. This can be through MDIO, two-wire slave, or 4-pin SPI.

**Figure 4 • Transparent Clock Line Card Application**



## 2.4.2 IEEE 1588v2 Transparent Clock and Boundary Clock

This system uses a central 1588 engine, most likely a CPU system, together with hardware support functions to generate sync frames (for boundary clock and ordinary clock masters). The switch fabric needs to have the ability to redirect (and copy) PTP frames to the 1588 Engine for processing. This system also works for pizza boxes.

The requirements for the system are as follows:

- Delivery of a synchronous global timetick clock (or reference clock).
- Delivery of a global timetick load to synchronize the local time counters in each port.
- CPU access to each PHY to set up the required configuration.

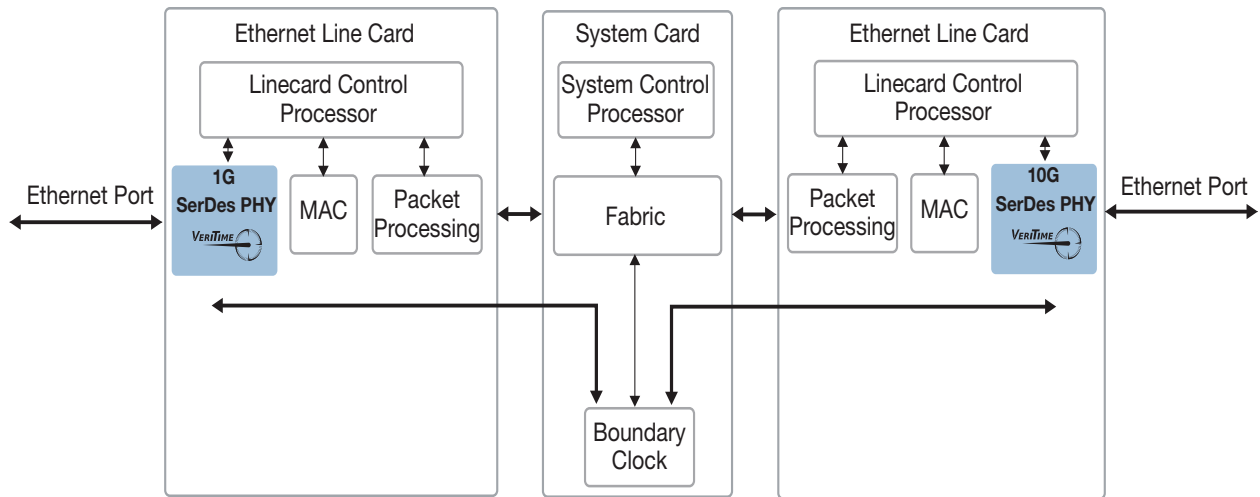
For one-step support, this can be through MDIO, two-wire slave, or 4-pin SPI.

For two-step support, a dedicated “push-out” SPI might be required, depending on the number of time stamps that are required to be read by the CPU. A blade system may require a local CPU/FPGA to collect the information and send it to the 1588 engine using either the control plane or the data plane. In advanced MAC/Switch devices, this may be accomplished using an internal CPU.

Fabric must be able to detect IEEE 1588 frames and redirect some of them to the central 1588 engine.

The same solution may also be used to add Y.1731 delay measurement support. This does not require a local CPU on the blade, but the switch fabric must be able to redirect OAM frames to a local/central OAM processor.

**Figure 5 • Boundary Clock Line Card Application**





## 3 Functional Descriptions

---

This section includes a functional block diagram, information on the operating modes, and descriptions of the major functional blocks of the VSC8257-01 device.

### 3.1 Data Path Overview

VSC8257-01 supports a protocol-aware Ethernet mode and a protocol agnostic Ethernet-bypass mode.

Ingress and egress data flow is relative to the line-side interface.

Both the host-side and the line-side interfaces are 10G SFI, 10GBASE-KR, or SGMII. Each lane has the following main sections.

- Line and host PMA: The PMA section contains the high speed serial I/O interfaces, an input equalization circuit, a 10GBASE-KR compliant output buffer and a SerDes. Additionally, the PMAs also generate all the clocks, including the clocks required for Synchronous Ethernet application.
- WIS: Contains the framing and de-framing circuits and the control and status registers to convert the data to be IEEE 802.3ae Clause 50 WIS-compliant.
- Line and host side 10GBase-R PCS: The 10GBase-R PCS section is composed of the PCS transmit, PCS receive, block synchronization, and BER monitor processes. The PCS functions can be further broken down into encode or decode, scramble or descramble, and gearbox functions, as well as various test and loopback modes.
- 1G PCS: Consists of the 1000BASE-X/SGMII coding and auto-negotiation processes. There are two instances per channel, one for the host and one for the line.
- IEEE 1588: Contains the local time counter, analyzer, time stamp FIFO, and rewriter to support both 1-step and 2-step clock timing. This section also performs 1588 frame detection, time stamp appending, header removal, and frame processing.
- MAC: Frames data for transmission over the network before passing the frame to the physical layer interface where it is transmitted as a stream of bits.
- FIFO: Contains a rate-compensating FIFO between the line rate and the host rate. The rate-compensating FIFO is used when the MACs are disabled.
- Flow Control Buffer: Performs rate compensation between the host and line interfaces when the device MACs are enabled.
- Cross connect: This cross connect allows interconnection between any channel such that link state is not affected by a switch. Also, it can be configured to switch based on a configurable set of events.
- 10GBASE-KR: Supports 10GBASE-KR training and auto-negotiation. The 10GBASE-KR driver includes programmable equalization accomplished by a three-tap finite impulse response (FIR) structure (IEEE 802.3ap compliant). Three-tap delays are achieved by three flip-flops clocked by the high speed serial clock (10G in 10G mode, 1 GHz in 1G mode). 10GBASE-KR auto-negotiation is supported on either the line side or the host side, but not both sides simultaneously.
- Loopbacks: Includes both system and network loopbacks to enhance engineering debugging and manufacturing testing capability.
- Management: Contains status and configuration registers, and the serial management interface logic to access them.

#### 3.1.1 Ingress and Egress Operation: Repeater (or Pass-Through) Mode

In repeater mode, data is received by the line-side interface (SFP+/1 GbE), deserialized, and passed to the host-side serializer through an elastic buffer that absorbs phase jitter/wander. In this mode, the transmit (serializer) clock is required to be synchronous to the incoming recovered clock. A digital synchronization block with filtering capabilities down to the khz range is used to align the receive and transmit clocks. As a result, the input jitter is filtered completely. Each direction (ingress and egress) is identical.

The following table lists the interface data rates for the device's Ethernet mode.

**Table 1 • Repeater (or Pass-through) Mode Interface Data Rates**

Operating Mode	Line-side Data Rate (Gbps)	Host-Side Interface	Host-Side Data Rate (Gbps)
10G LAN	1 x 10.3125	10G LAN	1 x 10.3125
1 GbE	1 x 1.25	1 GbE	1 x 1.25
10G OTU2	1 x 10.709	OTU2	1 x 10.709
10G OTU1e	1 x 11.049	OTU1e	1 x 11.049
10G OTU2e	1 x 11.095	OTU2e	1 x 11.095

### 3.1.2 Ingress Operation: Ethernet Mode

Data is received by the line-side interface (SFP+/1 GbE), processed by core logic, and transmitted from the host-side interface (SFP+/1 GbE) in the ingress or line-side receive data path.

High-speed serial data is received by the PMA. Data can be equalized and is delivered to the clock recovery unit (CRU). The received serial data must be a 66B/64B encoded Ethernet frame at 10.3125 Gbps in 10G LAN mode, a SONET/SDH STS-192c frame at 9.953 Gbps in 10G WAN mode, or 8B/10B encoded data at 1.25 Gbps in 1 GbE mode.

In 10G WAN mode, the CRU data is processed by the WIS where 66B/64B encoded Ethernet data is extracted from SONET/SDH STS-192c frames and overhead bytes are processed. The extracted payload data is then processed by the 10G PCS. In 10G LAN mode, the CRU data is processed by a 10G PCS. In 1G mode, the CRU data is processed by the line-side 1G PCS. The 1G/10G PCS data can be optionally processed by the IEEE 1588 and two MAC logic blocks.

In 10G LAN and WAN modes, data from the core is 64B/66B decoded by the host side 10G PCS logic and serialized in the host-side serdes. In 1 GbE mode, data from the core is 8B/10B encoded by the host-side 1G PCS logic and serialized in the host-side serdes.

### 3.1.3 Egress Operation: Ethernet Mode

Data is received by the host-side interface (SFP+/1 GbE), processed by core logic, and transmitted from the line-side interface (SFP+/1 GbE) in the egress or line-side transmit data path.

In 10G mode, a clock is recovered incoming data in the host-side serdes. The data deserialized in the host PMA and then 64B/66B-decoded in the host 10G PCS. It is then optionally processed by the IEEE 1588 and two MAC logic blocks. The data is then 66B/64B-encoded by the line 10G PCS logic. The data is serialized by the PMA in 10G LAN mode and transmitted from the line interface at 10.3125 Gbps. When the WIS logic is enabled in 10G WAN mode, a SONET/SDH STS-192c frame is created using the 66B/64B-encoded data as the frame's payload. The WIS data is serialized by the PMA and transmitted from the line interface at 9.953 Gbps.

In 1G mode, a clock is recovered from 1 GbE data in the host-side serdes. The data is 8B/10B-decoded by the host-side 1G PCS, then optionally processed by the IEEE 1588 and two MAC logic blocks. The data is 8B/10B-encoded by the line-side 1G PCS logic. It is serialized by the PMA and transmitted from the line interface at 1.25 Gbps.

The following table lists the interface data rates for the device's Ethernet mode.

**Table 2 • Ethernet Mode Interface Data Rates**

Operating Mode	Line-Side Data Rate (Gbps)	Host-side Interface	Host-side Data Rate (Gbps)
10G LAN	1 x 10.3125	10G LAN	1 x 10.3125
10G WAN	1 x 9.95328	10G LAN	1 x 10.3125
1 GbE	1 x 1.25	1 GbE	1 x 1.25

## 3.2 Physical Media Attachment (PMA)

The PMA section consists of receiver (Rx) and transmitter (Tx) subsections. The receiver accepts data from the serial data input RXIN and sends the parallel data to the elastic buffer. A data rate clock also accompanies the parallel data. The transmitter accepts parallel data from the elastic buffer and transmits at serial data output TXOUT. A loopback at the data path is also provided to connect the Rx and the Tx subsections.

Serial data is pre-equalized in the input buffer, and clock and data are recovered in the deserializer. A demux then deserializes the data into a parallel core data interface. An RC PLL in the Rx subsection is used as reference for clock and data recovery. Locked to the incoming datastream, a lane sync signal is derived from the PLL clock, which is used for source synchronous data transmission to one or multiple transmitters.

The Tx subsection is made up of the serializer, the output buffer, and the RC PLL. A mux then serializes the data from the PCS or WIS to a high-speed serial stream, which is forwarded to a 3-tap filter output buffer. The RC PLL in the Tx subsection is used to generate the high-speed clock used in the serializer.

To support different data rates, each PMA contains a flexible frequency synthesizer that generates the necessary clocks. The PMA also has four fully programmable clock outputs, CKOUT[0:3], that may be used to output various clock domains from the PMA.

### 3.2.1 Reference Clock

The VSC8257-01 device uses three differential input CML level reference clocks: LREFCK, HREFCK, and SREFCK. LREFCK and HREFCK are required at all times and have to be synchronous. They may be 125 MHz or 156.25 MHz. This rate must be selected at power-up using the MODE[1:0] pins. LREFCK and HREFCK are multiplied to generate the reference clocks for all the SerDes blocks in the line and host-side interfaces respectively.

SREFCK may be used for Synchronous Ethernet applications.

The following table shows the MODE pin settings for the various LREFCK frequencies.

**Table 3 • Selecting LREFCK Frequency**

MODE1 Pin	MODE0 Pin	Frequency
0	0	156.25 MHz (default)
1	0	125 MHz

### 3.2.2 VScope™ Input Signal Monitoring Integrated Circuit

The VScope™ input signal monitoring integrated circuit displays the input signal before it is digitized by the CDR. The two primary configurations are as follows:

- Unity Gain Amplifier monitors the 10 Gbps input signals before signal processing and equalization. VScope input signal monitoring integrated circuit acts as a virtual scope to effectively observe the received data signal before it has been processed. The autonomous adaptive filter taps must first be disabled and the front-end receiver must be set for operation as a linear, unity gain amplifier. In this mode, all DFE taps are set to zero. This mode does not require an adaptive algorithm.
- Link Monitor provides the link margin. VScope input signal monitoring integrated circuit enables design engineers and system developers to monitor signals remotely without disrupting the data integrity of a live data path. By monitoring the health of a given link, optical or electrical, various types of signal degradation can be identified and corrected.

**Note:** The VScope input signal monitoring integrated circuit feature is only available in the 10G operation mode.

### 3.2.3 10GBASE-KR

The VSC8257-01 device implements the 10GBASE-KR standard in hardware with no additional firmware requirement for 10GBASE-KR backplane rate auto-negotiation and link training per IEEE 802.3 clause

72 and 73. The 10GBASE-KR output driver itself may be used outside the 10GBASE-KR backplane application and is set by programming the registers.

### 3.2.3.1 Rate Auto-Negotiation

The VSC8257-01 device supports auto-detection between 1.25 Gbps and 10.3125 Gbps data rates, according to the IEEE 802.3ap Clause 73. The auto-negotiation/auto-detection feature switches the CRU rate selection to different rates.

Rate auto-negotiation enables devices at both ends of a link segment to advertise abilities, acknowledge receipt, and discover the common modes of operation that both devices share, and to reject the use of operational modes that are not shared by both devices. Where more than one common mode exists between the two devices, a mechanism is provided to allow the devices to resolve to a single mode of operation using a predetermined priority resolution function. The auto-negotiation function allows the devices to switch between the various operational modes in an orderly fashion, permits management to disable or enable the auto-negotiation function, and allows management to select a specific operational mode. The auto-negotiation function also provides a parallel detection function to allow backplane Ethernet devices to connect to other backplane Ethernet devices that have auto-negotiation disabled and interoperate with legacy devices that do not support Clause 73 Auto-Negotiation.

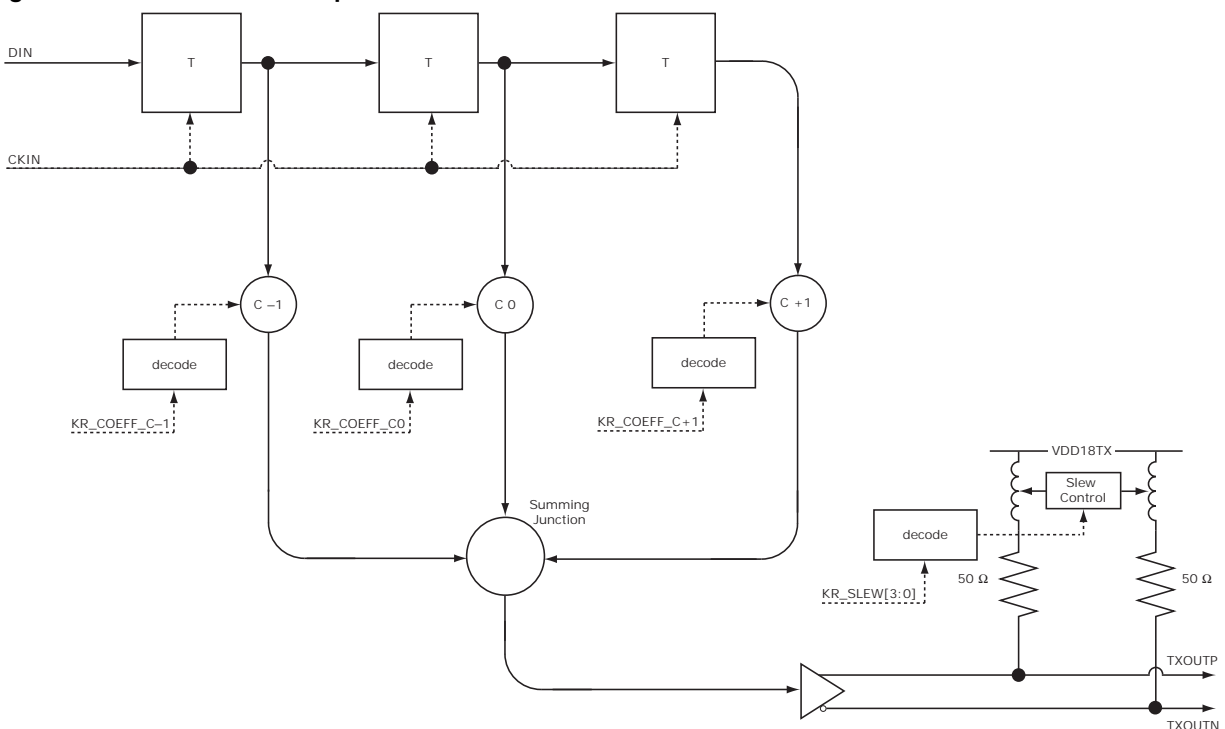
### 3.2.3.2 Training

The purpose of training is to establish optimal settings for the VSC8257-01 device and the link partner. For more information about the training function, see IEEE 802.3ap Clause 72.

### 3.2.3.3 Output Driver

The high-speed output driver includes programmable equalization accomplished by a three-tap finite impulse response (FIR) structure. The three-tap delays are achieved by three flip-flops clocked by a high-speed serial clock, as shown in the following illustration. Coefficients  $C(-1)$ ,  $C(0)$ , and  $C(+1)$  adjust the pre-cursor, main-cursor, and post-cursor of the output waveform. The three delayed data streams, after being properly strength adjusted by their coefficients, are summed by a summing amplifier. The output driver meets the requirements defined in IEEE 802.3ap Clause 72.

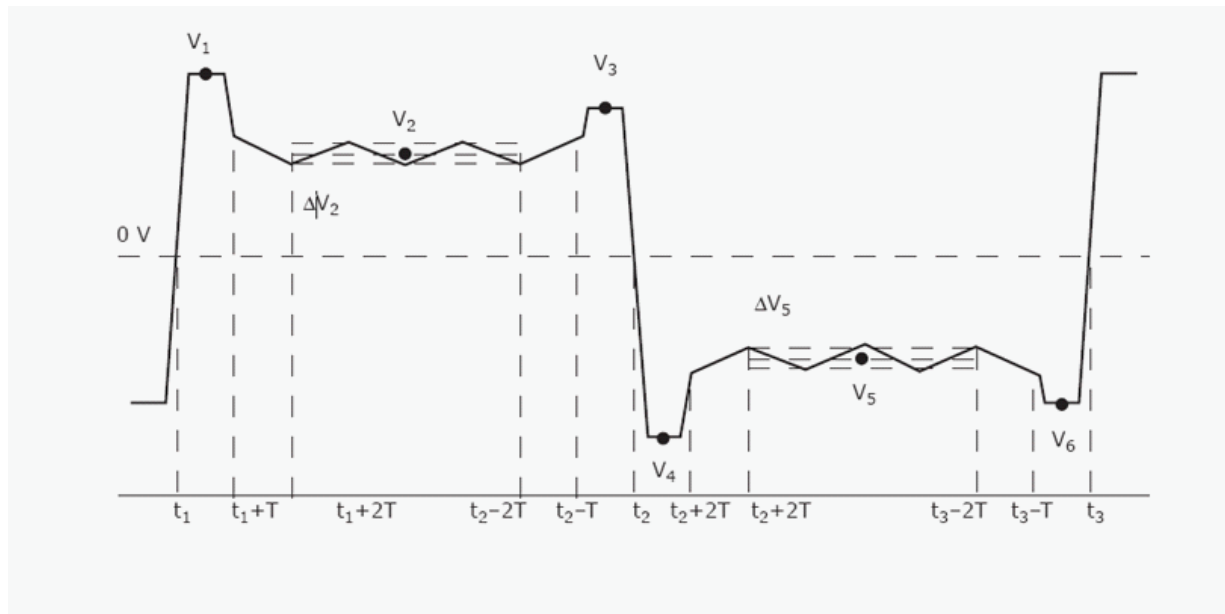
Figure 6 • 10GBASE-KR Output Driver



The final output stage has 50  $\Omega$  back-termination with inductor peaking. The output slew rate is controlled by adjusting the effectiveness of the inductors.

The test pattern for the transmitter output waveform is the square wave test pattern with at least eight consecutive 1s. The following illustration shows the transmitter output waveform test, based on voltages V1 through V6,  $\Delta V_2$ , and  $\Delta V_5$ .

**Figure 7 • 10GBASE-KR Test Pattern**



The output waveform is manipulated through the state of the coefficient C(-1), C(0), and C(+1).

### 3.3 Wide Area Network Interface Sublayer (WIS)

The WAN interface sublayer (WIS) is defined in IEEE 802.3ae Clause 50. The WIS block is fully compliant with this specification. Additionally, the VSC8257-01 device offers an extended set of controls, ports, and registers, called eWIS, to allow integration into a wider array of SONET/SDH equipment.

In addition to the SONET/SDH features addressed by WIS as defined by IEEE, most SONET/SDH framers/mappers contain additional circuitry for implementing operation, administration, maintenance, and provisioning (OAM&P). These framers/mappers also support special features to enable compatibility with legacy SONET/SDH solutions. Because the eWIS leverages Microsemi's industry leading framer/mapper technology, it contains suitable features for standard SONET/SDH equipment. This includes the transmit/receive overhead serial interfaces (TOSI/ROSI) commonly used for network customization and OAM&P, support for SONET/SDH errors not contained in the WIS standard, support for common legacy SONET/SDH implementations, and SONET/SDH jitter and timing quality.

#### 3.3.1 Operation

WAN mode is enabled by asserting 2x0007.0 (SPI/MDIO/TWS) or `wis_ctrl2.wan_mode`. Status register bit `Vendor_Specific_PMA_Status_2.WAN_ENABLED_status` indicates whether WAN mode is enabled or not. It is not possible to have WAN mode in the Tx path enabled while the Rx path is disabled, or vice versa. An "X" in the table represents a don't care state.

**Note:** After WAN mode is enabled, write both bit 2 and 1 of 1xAE00 to high to reset the Tx and Rx PCS blocks and enable valid WAN data to pass through.

The transmit portion of the WIS does the following:

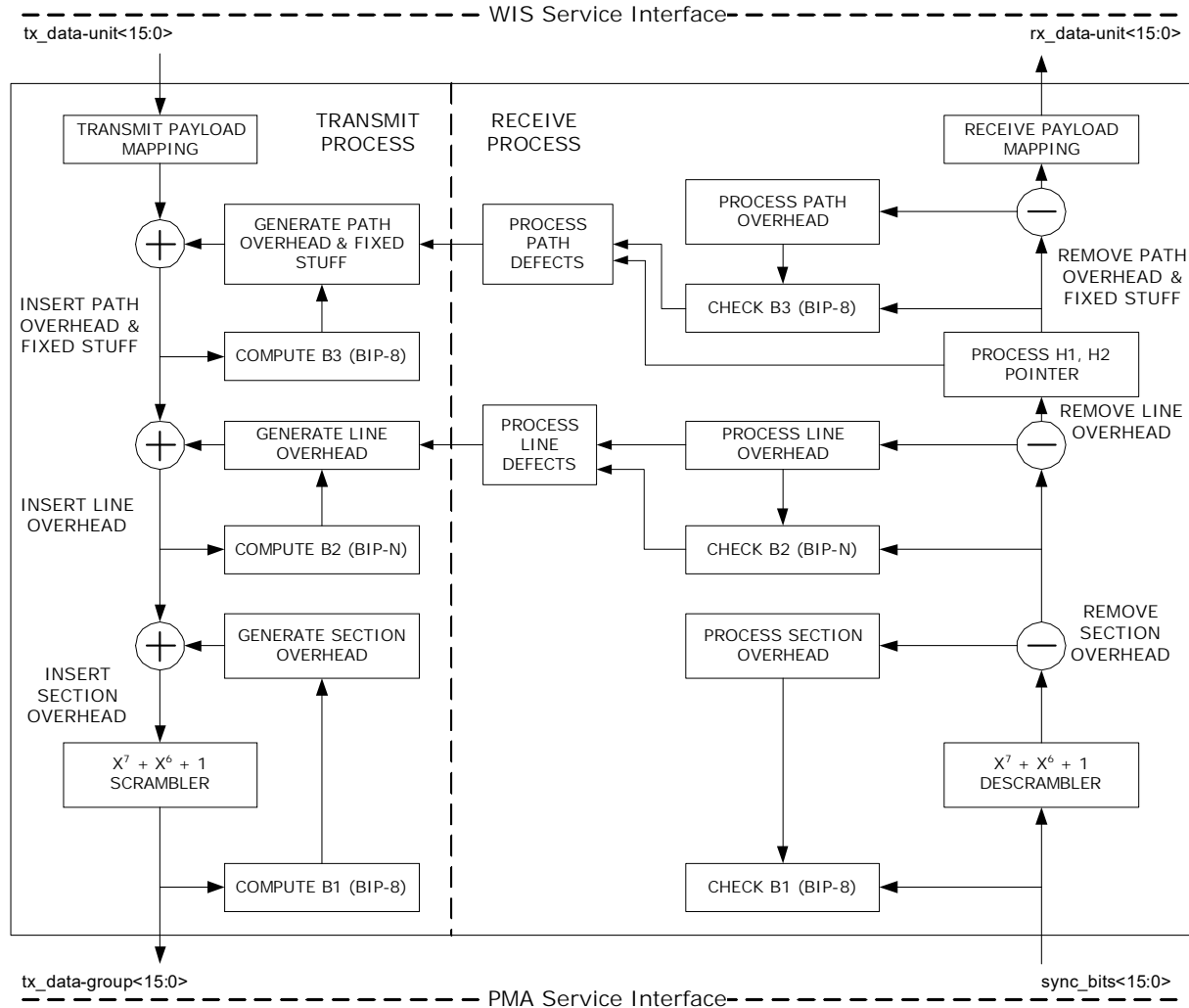
- Maps data from the PCS through the WIS service interface and to the SONET/SDH synchronous payload envelope (SPE)
- Generates path, line, and section overhead octets
- Scrambles the frame
- Transmits the frame to the PMA service interface

The receive portion of the WIS does the following:

- Receives data from the PMA service interface
- Delineates octet and frame boundaries
- Descrambles the frame
- Processes section, line, and path overhead information that contain alarms and parity errors
- Interprets the pointer field
- Extracts the payload for transmittal to the PCS through the WIS service interface

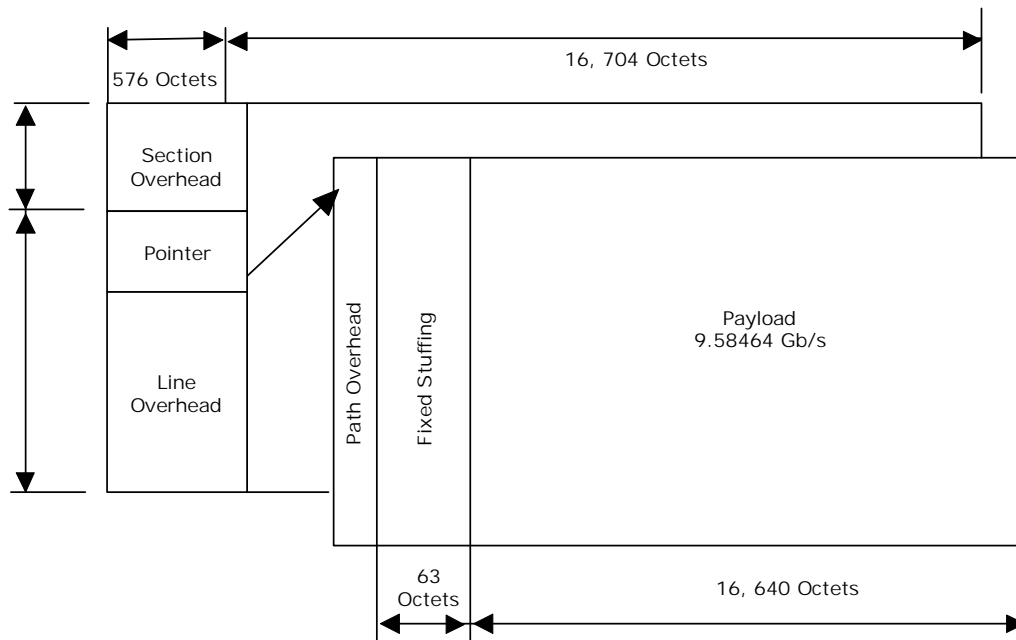
The following illustration shows the WIS block diagram.

**Figure 8 • WIS Transmit and Receive Functions**



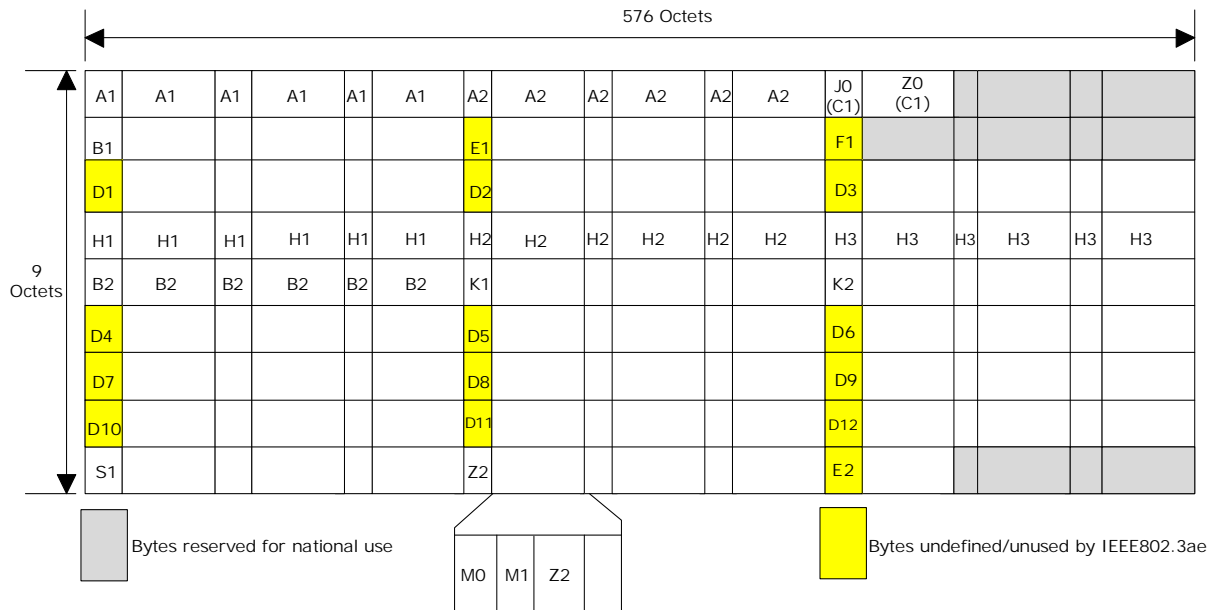
The following illustration shows the WIS frame structure.

**Figure 9 • eWIS Frame Structure**

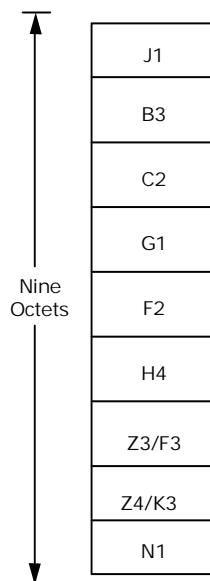


The following illustration shows the positions of the STS-192c/STM-64 section and line overhead octets within the WIS frame.

**Figure 10 • STS-192c/STM-64 Section and Line Overhead in the WIS**



The following illustration shows the path overhead octet positions.

**Figure 11 • STS-192c/STM-64 Path Overhead in the WIS**


### 3.3.2 Section Overhead

The section overhead portion of the SONET/SDH frame supports frame synchronization, a tandem connection monitor (TCM) known as the Section Trace, a high-level parity check, and some OAM&P octets. The following table lists each of the octets including their function, specification, and related information.

The VSC8257-01 device provides a mechanism to transmit a static value as programmed by the MDIO interface. However, by definition, MDIO is not fast enough to alter the octet on a frame-by-frame basis.

**Table 4 • Section Overhead Functions and Recommended Values**

Overhead Octet	Function	IEEE 802.3ae WIS Use	Recommended Value	WIS Extension
A1	Frame alignment	Supported	0xF6	Register (EWIS_TX_A1_A2) TOSI and ROSI access
A2	Frame alignment	Supported	0x28	Register (EWIS_TX_A1_A2) TOSI and ROSI access
J0	Section trace	Specified value	For more information, see <a href="#">Section Trace (J0)</a> , page 20.	A 1-byte, 16-byte, or 64-byte trace message can be sent using registers WIS_Tx_J0_Octets_1_0 to WIS_Tx_J0_Octets_15_14, EWIS_TX_MSGLEN, or EWIS_Tx_J0_Octets_17_16 to EWIS_Tx_J0_Octets_63_62 and received using registers
Z0	Reserved for section growth	Unsupported	0xCC	Register EWIS_TX_Z0_E1 TOSI and ROSI access.



**Table 4 • Section Overhead Functions and Recommended Values (continued)**

Overhead Octet	Function	IEEE 802.3ae WIS Use	Recommended Value	WIS Extension
B1	Section error monitoring (Section BIP-8)	Supported	Bit interleaved parity - 8 bits, as specified in T1.416	Using the TOSI, the B1 byte can be masked for test purposes. For each B1 mask bit that is cleared to 0 on the TOSI interface, the transmitted bit is left unchanged. For each B1 mask bit that is set to 1 on the TOSI interface, the transmitted bit is inverted.  Using the ROSI, the B1 error locations can be extracted. Periodically latched counter (EWIS_B1_ERR_CNT1-EWIS_B1_ERR_CNT0) is available.
E1	Orderwire	Unsupported	0x00	Register EWIS_TX_Z0_E1 TOSI and ROSI access.
F1	Section user channel	Unsupported	0x00	Register EWIS_TX_F1_D1 TOSI and ROSI access.
D1 - D3	Section data communications channel (DCC)	Unsupported	0x00	Register EWIS-TX_F1_D1 to EWIS_TX_D@_D3 TOSI and ROSI access

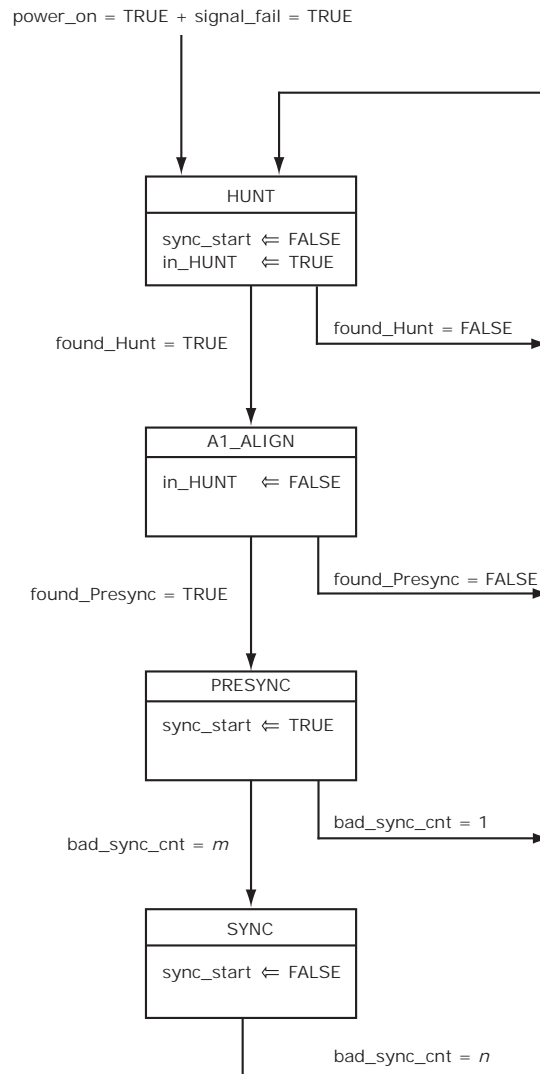
### 3.3.3 Frame Alignment (A1, A2)

The SONET/SDH protocol is based upon a frame structure which is delineated by the framing octets A1 and A2. The framing octets are defined to be 0xF6 and 0x28 respectively. In the transmit direction, all 192 A1 octets are sourced from the TX\_A1 (EWIS\_TX\_A1\_A2.TX\_A1) register while the A2 octets are sourced from the TX\_A2 (EWIS\_TX\_A1\_A2.TX\_A2) register.

In the receive direction, the frame aligner monitors the input bus from the PMA and performs word alignment. The frame alignment architecture is composed of a primary and secondary state machine. The selected frame alignment and synchronization pattern have implications on the tolerated input BER. The higher the input BER, the less likely the frame boundary can be found. The chances of finding the frame boundary are improved by reducing the number of A1/A2 bytes required to be detected (using a smaller pattern width). According to the WIS specification, the minimum for all parameters allows a signal with an error tolerance of 10-12 to be framed.

The following illustration shows the primary synchronization state diagram.

**Figure 12 • Synchronization State Diagram**



The following table lists the variables for the primary state diagram. The variables are reflected in registers (EWIS\_RX\_FRM\_CTRL1 and EWIS\_RX\_FRM\_CTRL2 that can be alternately reconfigured).

**Table 5 • Framing Parameter Description and Values**

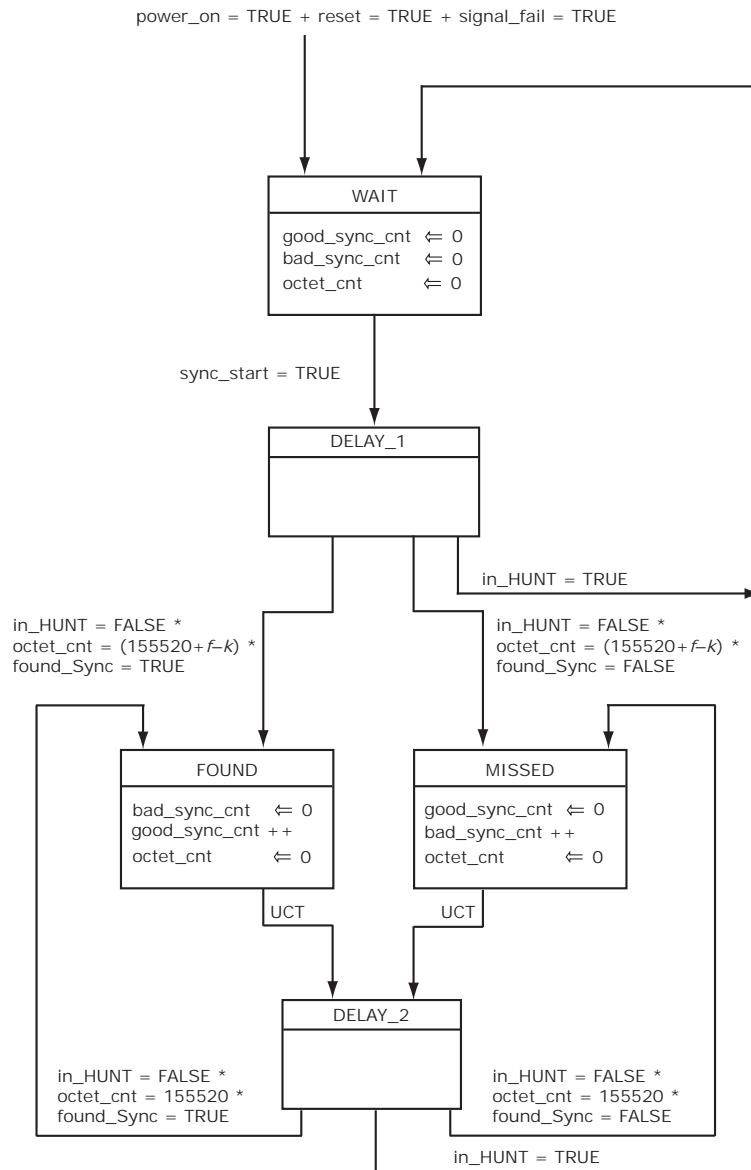
Name	Description	IEEE 802.3ae Parameter	IEEE 802.3ae Range	Range	Default
Sync_Pattern width	Sequence of f consecutive A1s followed immediately by a sequence of f consecutive A2s. If f = 2, Sync_Pattern is A1A1A2A2	f	2 to 192	0 to 16 Exceptions: If f = 0, Sync_Pattern is A1 + 4 MSBs of A2. If f = 1, Sync_Pattern is A1A1A2	2
Hunt_Pattern width	Sequence of i consecutive A1s	i	1 to 192	1 to 16	4

**Table 5 • Framing Parameter Description and Values (continued)**

Name	Description	IEEE 802.3ae Parameter	IEEE 802.3ae Range	Range	Default
Presync_Pattern A1 width	Sequence of j consecutive A1s followed immediately by a sequence of k consecutive A2s	j	16 to 190	1 to 16 If set to 0, behaves as if set to 1. If set to 17 to 31, behaves as if set to 16	16
Presync_Pattern A2 width	Sequence of j consecutive A1s followed immediately by a sequence of k consecutive A2s	k	16 to 192	0 to 16 0 means only 4 MSB of A2 are used. If set to 17 to 31, behaves as if set to 16	16
SYNC state entry	Number of consecutive frame boundaries needed to be found after entering the PRESYNC state in order to enter the SYNC state	m	4 to 8	1 to 15 If set to 0, behaves as if set to 1	4
SYNC state exit	Number of consecutive frame boundary location errors detected before exiting the SYNC state	n	1 to 8	1 to 15 If set to 0, behaves as if set to 1	4

The following diagram shows the secondary state.

**Figure 13 • Secondary SYNC State Diagram**



### 3.3.4 Loss of Signal (LOS)

WIS\_STAT3.LOS alarm status is a latch-high register; back-to-back reads provide both the event as well as status information. The LOS event also asserts register EWIS\_INTR\_PEND1.LOS\_PEND until read. This event can propagate an interrupt to either WIS\_INTA or WIS\_INTB based upon mask enable bits EWIS\_INTR\_MASKA\_1.LOS\_MASKA and EWIS\_INTR\_MASKB\_1.LOS\_MASK.

There is no hysteresis on the LOS detection, and so it is recommended to have the system software to implement a sliding window to check on the LOS before qualifying the presence of a signal. As an alternative, Rx\_LOS can be used from the optical module (through LOPC) to qualify the input signal. In addition to using analog detection, digital detection such as PCS\_Rx\_Fault is recommended to determine if the input signal is good.

When the near-end device experiences LOS, it is possible to automatically transmit a remote defect indication (RDI-L) to the far-end for notification purposes. The EWIS\_RXTX\_CTRL.TXRDIL\_ON\_LOS, if asserted, overwrites the outgoing K2 bits with the RDI-L code. In the receive path, it is possible to trigger an AIS-L state (alarm assertion plus forcing the payload to an all ones state) upon a detection of an LOS condition. This is accomplished by asserting EWIS\_RXTX\_CTRL.RXAISL\_ON\_LOS.

### 3.3.5 Loss of Optical Carrier (LOPC)

The input pin LOPC can be used by external optic components to directly assert the loss of optical power to the physical media device. Any change in level on the LOPC input asserts register EWIS\_INTR\_PEND2.LOPC\_PEND until read. The current status of the LOPC input pin can be read in register EWIS\_INTR\_STAT2.LOPC\_STAT. The LOPC input can be active high or active low by setting the Vendor\_Specific\_LOPC\_Control.LOPC\_state\_inversion\_select bit appropriately. The LOPC\_PEND bit can propagate an interrupt to either WIS\_INTA or WIS\_INTB based upon mask enable bits EWIS\_INTR\_MASKA\_2.LOPC\_MASKA and EWIS\_INTR\_MASKB\_2.LOPC\_MASKB.

When the near-end device experiences LOPC, it is possible to automatically transmit a remote defect indication (RDI-L) to the far-end to notify it of a problem. The EWIS\_RXTX\_CTRL.TXRDL\_ON\_LOPC register bit, if asserted, overwrites the outgoing K2 bits with the RDI-L code. In the receive path, it is possible to force the receive framer into an LOF state, thereby squelching subsequent alarms and invalid payload data processing. This is accomplished by asserting EWIS\_RX\_ERR\_FRC1.RXLOF\_ON\_LOPC. Similar to the LOF condition forced upon an LOPC, the EWIS\_RXTX\_CTRL.RXAISL\_ON\_LOPC can force the AIS-L alarm assertion, plus force the payload to an all ones state to indicate to the PCS the lack of valid data, upon an LOPC condition.

### 3.3.6 Severely Errored Frame (SEF)

Upon reset, the Rx WIS enters the out of frame (OOF) state with both the severely errored frame (SEF) and loss of frame (LOF) alarms active. The SEF state is terminated when the framer enters the SYNC state. The framer enters the SYNC state after EWIS\_RX\_FRM\_CTRL2.SYNC\_ENTRY\_CNT plus 1 consecutive frame boundaries are identified. An SEF state is declared when the framer enters the out-of-frame (OOF) state. The frame changes from the SYNC state to the OOF state when EWIS\_RX\_FRM\_CTRL2.SYNC\_EXIT\_CNT consecutive frames with errored frame alignment words are detected. The SEF alarm condition is reported in WIS\_STAT3.SEF.

This register latches high providing a combination of interrupt pending and status information within consecutive reads.

An additional bi-stable interrupt pending bit SEF\_PEND (EWIS\_INTR\_PEND1.SEF\_PEND) is provided to propagate an interrupt to either WIS\_INTA or WIS\_INTB based upon mask enable bits SEF\_MASKA (EWIS\_INTR\_MASKA\_1.SEF\_MASKA) and SEF\_MASKB (EWIS\_INTR\_MASKB\_1.SEF\_MASKB).

### 3.3.7 Loss of Frame (LOF)

An LOF occurs when an out of frame state persists for an integrating period of EWIS\_LOF\_CTRL1.LOF\_T1 frames. To provide for the case of intermittent OOFs, when not in the LOF state, the integrating timer is not reset to zero until an in-frame condition persists continuously for EWIS\_LOF\_CTRL1.LOF\_T2 frames. The LOF state is exited when the in-frame state persists continuously for EWIS\_LOF\_CTRL2.LOF\_T3 frames. The LOF state is indicated by the WIS\_STAT3.LOF register being asserted. This register latches high, providing a combination of pending and status information over consecutive reads.

An additional bi-stable interrupt pending bit, EWIS\_INTR\_PEND1.LOF\_PEND, is provided to propagate an interrupt to either WIS\_INTA or WIS\_INTB based upon mask enable bits EWIS\_INTR\_MASKA\_1.LOF\_MASKA and EWIS\_INTR\_MASKB\_1.LOF\_MASKB.

When the near-end device experiences an LOF condition, it is possible to automatically transmit a remote defect indication (RDI-L) to the far end to notify it of a problem. The EWIS\_RXTX\_CTRL.TXRDL\_ON\_LOF, if asserted, overwrites the outgoing K2 bits with the RDI-L code. In the receive path, it is possible to force a AIS-L state (alarm assertion plus forcing the payload to an all ones state) upon a detection of an LOF condition. This is accomplished by asserting EWIS\_RXTX\_CTRL.RXAISL\_ON\_LOF.

### 3.3.8 Section Trace (J0)

The J0 octet often carries a repeating message called the Section Trace message. The default transmitted message length is 16 octets whose contents are defined in WIS\_TXJ0 (WIS\_Tx\_J0\_Octets\_1\_0-WIS\_Tx\_J0\_Octets\_15\_14). If no active message is being broadcast, a default section trace message is transmitted. This section trace message consists of 15 octets of zeros and a

header octet formatted according to Section 5 of ANSI T1.269-2000. The header octet for the 15-octets of zero is 0x89. The default values of WIS\_TXJ0 (WIS\_Tx\_J0\_Octets\_1\_0-WIS\_Tx\_J0\_Octets\_15\_14) do not contain the 0x89 value of the header octet, so software must write this value.

The J0 octet in the receive direction is assumed to be carrying a 16-octet continuously repeating section trace message. The message is extracted from the incoming WIS frames and stored in WIS\_RXJ0 (WIS\_Rx\_J0\_Octets\_1\_0-WIS\_Rx\_J0\_Octets\_15\_14). The WIS receive process does not delineate the message boundaries, thus the message might appear rotated between new frame alignment events.

The VSC8257-01 device supports two alternate message types, a single repeating octet and a 64-octet message. The message type can be independently selected for the transmit and receive direction. The transmit direction is configured using EWIS\_TX\_MSGLEN.J0\_TXLEN while EWIS\_RX\_MSGLEN.J0\_RX\_LEN configures the receive path.

When the transmit direction is configured for a 64-octet message, the first 16 octets are programmed in WIS\_TXJ0 (WIS\_Tx\_J0\_Octets\_1\_0-WIS\_Tx\_J0\_Octets\_15\_14), while the 48 remaining octets are programmed in EWIS\_TXJ0 (EWIS\_Tx\_J0\_Octets\_17\_16-EWIS\_Tx\_J0\_Octets\_63\_62). Likewise, the first 16 octets of the receive message are stored in WIS\_RXJ0 (WIS\_Rx\_J0\_Octets\_1\_0-WIS\_Rx\_J0\_Octets\_15\_14), while the other 48 octets are stored in EWIS\_RXJ0 (EWIS\_Rx\_J0\_Octets\_17\_16-EWIS\_Rx\_J0\_Octets\_63\_62). The receive message is updated every 125  $\mu$ s with the recently received octet. Any persistency or message matching is expected to take place within the station manager.

### 3.3.9 Reserved for Section Growth (Z0)

The WIS standard does not support the Z0 octet and requires transmission of 0xCC in the octet locations. A different Z0 value can be transmitted by configuring EWIS\_TX\_Z0\_E1.TX\_Z0. The TX\_Z0 default is 0xCC.

### 3.3.10 Scrambling/Descrambling

The transmit signal (except for row 1 of the section overhead) is scrambled according to the standards when register bit EWIS\_TXCTRL2.SCR is asserted, which is the default state. When deasserted, the scrambler is disabled.

The receive signal descrambler is enabled by default. The descrambler can be bypassed by deasserting register bit EWIS\_RX\_CTRL1.DSCR\_ENA.

Enabling loopback H4 and turning off the WIS scrambler and descrambler may yield an interesting data point when debugging board setups. The CRU in the ingress PMA path would not have enough edge transitions in the data to reliably recover the clock if the chip were receiving non-scrambled data. The same would be true for any far-end device connected to the egress PMA if the scrambler were turned off. The WIS scrambler and descrambler should be left on under normal operating conditions.

### 3.3.11 Section Error Monitoring (B1)

The B1 octet is a bit interleaved parity-8 (BIP-8) code using even parity calculated over the previous STS-192c frame, post scrambling. The computed BIP-8 is placed in the following outgoing SONET frame before scrambling.

In the receive direction, the incoming frame is processed, and a BIP-8 is calculated. The calculated value is then compared with the B1 value received in the following frame. The difference between the calculated and received octets are accumulated into the WIS\_B1\_CNT register. This counter rolls over after the maximum count. This counter is cleared upon device reset.

The EWIS\_B1\_ERR\_CNT1 and EWIS\_B1\_ERR\_CNT0 registers provide a count of the number of received B1 parity errors. This register is updated with the internal count value upon a PMTICK condition, after which the internal counter is reset to zero. When the counter is nonzero, the EWIS\_INTR\_PEND2.B1\_NZ\_PEND event register is asserted until read. A non-latch high version of this event, EWIS\_INTR\_STAT2.B1\_NZ\_STAT, is also available. This event can propagate an interrupt to either WIS\_INTA or WIS\_INTB based upon mask enable bits EWIS\_INTR\_MASKA\_2.B1\_NZ\_MASKA and EWIS\_INTR\_MASKB\_2.B1\_NZ\_MASKB.

The B1\_ERR\_CNT can optionally be configured to increment on a block count basis, a maximum increment of 1 per errored frame regardless of the number of errors received. This mode is enabled by asserting EWIS\_CNT\_CFG.B1\_BLK\_MODE.

### 3.3.12 Section Orderwire (E1)

The WIS standard does not support the E1 octet and requires transmission of 0x00 in the octet location. A different E1 value can be transmitted by configuring EWIS\_TX\_Z0\_E1.TX\_E1 whose default is 0x00.

### 3.3.13 Section User Channel (F1)

The WIS standard does not support the F1 octet and requires transmission of 0x00 in the octet location. A different F1 value can be transmitted by configuring EWIS\_TX\_F1\_D1.TX\_F1 whose default is 0x00.

### 3.3.14 Section Data Communication Channel (DCC-S)

The WIS standard does not support the DCC-S octets and requires transmission of 0x00 in the octet locations. Different DCC-S values can be transmitted by configuring EWIS\_TX\_F1\_D1.TX\_D1, EWIS\_TX\_D2\_D3.TX\_D2, and EWIS\_TX\_D2\_D3.TX\_D3, all of which default to 0x00.

### 3.3.15 Reserved, National, and Unused Octets

The VSC8257-01 device transmits 0x00 for all reserved, national, and unused overhead octets.

### 3.3.16 Line Overhead

The line overhead portion of the SONET/SDH frame supports pointer interpretation, a per channel parity check, protection switching information, synchronization status messaging, far-end error reporting, and some OAM&P octets.

The VSC8257-01 device provides a mechanism to transmit a static value as programmed by the MDIO interface. However, by definition, MDIO is not fast enough to alter the octet on a frame-by-frame basis. The following table lists each of the octets including their function, specification, and related information.

**Table 6 • Line Overhead Octets**

Octet Number	Function	IEEE 802.3AE	Recommended Value	WIS Extension
H1-H2	Pointer	Specified value	SONET mode: STS-1: 0x62, 0x0A STS-n: 0x93, 0xFF SDH mode: STS-1: 0x6A, 0x0A STS-n: 0x9B, 0xFF	Registers EWIS_TX_C2_H1.TX_H1 and EWIS_TX_H2_H3.TX_H2 TOSI and ROSI access.
H3	Pointer action	Specified value	0x00	Register EWIS_TX_H2_H3.TX_H3 TOSI and ROSI access

**Table 6 • Line Overhead Octets (continued)**

Octet Number	Function	IEEE 802.3AE	Recommended Value	WIS Extension
B2	Line error monitoring (Line BIP-1536)	Supported	BIP-8, as specified in T1.416	Using the TOSI, the B2 bytes can be masked for test purposes. For each B2 mask bit that is cleared to 0 on the TOSI interface, the transmitted bit is left unchanged. For each B2 mask bit that is set to 1 on the TOSI interface, the transmitted bit is inverted. Using the ROSI, the B2 error locations can be extracted. Periodically latched counter (EWIS_B1_ERR_CNT1-EWIS_B1_ERR_CNT0) is available
K1, K2	Automatic protection	Specified value	For more information about K2 encoding, see <a href="#">Table 7</a> , page 25.	Registers EWIS_TX_G1_K1.TX_K1 and EWIS_TX_K1_F2.TX_K2 TOSI and ROSI access
D4–D12	Line data communications channel (DCC)	Unsupported	0x00	Registers EWIS_TX_D4_D5 and EWIS_TX_D6_H4 TOSI and ROSI access
S1	Synchronization messaging	Unsupported	0x00	Register EWIS_TX_S1_Z1.TX_S1 TOSI and ROSI access
Z1	Reserved for line growth	Unsupported	0x00	Register EWIS_TX_S1_Z1.TX_Z1 TOSI and ROSI access
M0/M1	STS-1/N line remote error	M0: unsupported M1: supported	0x00/number of detected B2 errors in the receive path, as specified in T1.416	TOSI and ROSI access. The device supports a mode that uses only M1 to back report REI-L (EWIS_MODE_CTR.REI_MODE = 0), and another mode that uses both M0 and M1 to back report REI-L (EWIS_MODE_CTR.REI_MODE = 1)
E2	Orderwire	Unsupported	0x00	Register EWIS_TX_Z2_E2.TX_E2 TOSI and ROSI access
Z2	Reserved for line growth	Unsupported	0x00	Register EWIS_TX_Z2_E2.TX_E2 TOSI and ROSI access

### 3.3.16.1 Line Error Monitoring (B2)

The B2 octet is a BIP-8 value calculated over each of the previous STS-1 channels excluding the section overhead and pre-scrambling. As the B2 octet is calculated on an STS-1 basis, there are 192 B2 octets within an STS-192/STM-64 frame. Each of the 192 calculated BIP-8 octets are then placed in the outgoing SONET/SDH frame.



**Note:** For SONET mode, when the number of errors detected in the B2 octet of a receive frame is greater than 255, the total count of detected errors is transmitted in more than one frame. Even when no B2 errors are detected in subsequent frames, the number of detected B2 errors going into an accumulator will be limited to 255 if more than 255 errors are detected in a frame. The Tx framer pulls the REI-L count out of the accumulator when REI-L is transmitted to be compliant with T1-105.

In the receive direction, the incoming frame is processed, a per STS-1 BIP-8 is calculated (excluding section overhead and after descrambling), and then compared to the B2 value in the following frame. Errors are accumulated in the WIS\_B2\_CNT1 and WIS\_B2\_CNT0 registers. This counter is non-saturating and so rolls over after its maximum count. The counter is cleared only on device reset.

An additional 32-bit B2 error counter is provided in B2\_ERR\_CNT (EWIS\_B2\_ERR\_CNT1 and EWIS\_B2\_ERR\_CNT0), which is a saturating counter and is latched and cleared based upon a PMTICK event. Errors are accumulated from the previous PMTICK event. When the counter is nonzero, the EWIS\_INTR\_PEND2.B2\_NZ\_PEND event register is asserted until read. A non-latch high version of this event is available in EWIS\_INTR\_STAT2.B2\_NZ\_STAT. This event can propagate an interrupt to either WIS\_INTA or WIS\_INTB, based on mask enable bits EWIS\_INTR\_MASKA\_2.B2\_NZ\_MASKA and EWIS\_INTR\_MASKB\_2.B2\_NZ\_MASKB.

The B2\_ERR\_CNT can optionally be configured to increment on a block count basis, a maximum increment of 1 per errored frame regardless of the number of errors received. This mode is enabled by asserting EWIS\_CNT\_CFG.B2\_BLK\_MODE.

It is possible that two sets of B2 bytes (from two SONET/SDH frames) are received by the Rx WIS logic in a period of time when only one M0/M1 octet is transmitted. In this situation, one of the two B2 error counts delivered to the Tx WIS logic is discarded. This situation occurs when the receive data rate is faster than the transmit data rate. Similarly, when the transmit data rate is faster than the receive data rate, a B2 error count is not available for REI-L insertion into the M0/M1 octets of the transmitted SONET/SDH frame. A value of zero is transmitted in this case. This behavior is achieved by using a FIFO to transfer the detected B2 error count from the receive to transmit domains.

A FIFO overflow or underflow condition is not considered an error. A FIFO overflow or underflow eventually occurs unless the transmit and receive interfaces are running at the same average data rate. Because the received and transmitted frames can differ by, at most, 40 ppm ( $\pm 20$  ppm) and still meet the industry standards, this “slip” can happen no more often than once every 3.1 seconds.

### 3.3.16.2 APS Channel and Line Remote Defect Identifier (K1, K2)

The K1 and K2 octets carry information regarding automatic protection switching (APS) and line remote defect identifier (RDI-L). The K1 octet and the most significant five bits of the K2 octet contain the APS channel information. The transmitted values can be configured at EWIS\_TX\_G1\_K1.TX\_K1 and EWIS\_TX\_K2\_F2.TX\_K2. The default values of all zeros are compliant with the WIS standard.

The three least significant bits within the K2 octet carry the RDI-L encoding, as defined by section 7.4.1 of ANSI T1.416-1999 and as shown in the following table.

**Table 7 • K2 Encoding**

Indicator	K2 Value for Bits 6, 7, and 8	Interpretation
RDI-L	110	<p>Remote error indication.</p> <p>For the receive process, an RDI-L defect occurs after a programmable number of RDI-L signals are received in contiguous frames and is terminated when no RDI-L is received for the same number of contiguous frames.</p> <p>An RDI-L can be forced by asserting EWIS_RX_ERR_FRC1.FRC_RX_RDIL.</p> <p>For the transmit process, the WIS standard does not indicate when or how to transmit RDI-L. There is an option to transmit K2 by programming it through the TOSI, by programming it using the K2_TX MDIO register, or by programming it based on the contents of the K2_TX register with bits 6, 7, and 8 modified depending on the status of the following: LOPC, LOS, LOF, AIS-L and their associated transmit enable bits enable bits TXRDIL_ON_LOPC, TXRDIL_ON_LOS, TXRDIL_ON_LOF and TXRDIL_ON_AISL in register EWIS_RXTX_CTRL.</p>
AIS-L	111	<p>Alarm indication signal (line).</p> <p>For the receive process, this is detected based on the settings of the K2 byte. When AIS-L is detected, the WIS link status is down and WIS_STAT3.AISL is set high.</p> <p>This also contributes to errored second (ES) and severally errored second (SES) reports.</p> <p>For standard WIS operation, this is never transmitted.</p>
Idle (normal)	000	Unless RDI-L exists, the standard WIS transmits IDLE.

Although the transmission of RDI-L is not explicitly defined within the WIS standard, the VSC8257-01 device allows the automatic transmission of RDI-L upon the detection of LOPC, LOS, LOF, or AIS-L conditions. These features are enabled by asserting TXRDIL\_ON\_LOPC, TXRDIL\_ON\_LOS, TXRDIL\_ON\_LOF and TXRDIL\_ON\_AISL in register EWIS\_RXTX\_CTRL.

**Note:** The RDI-L code of 110 is transmitted by the DUT only when Rx AIS-L is asserted. For example, if AIS-L is detected by the DUT for five continuous frames in the Rx direction, then the RDI-L code is transmitted for five frames in the Tx direction, not 20 frames as stated in the ANSI T1.105 specification.

The VSC8257-01 device can force an RDI-L condition independent of the K2 transmit value by asserting EWIS\_TXCTRL2.FRC\_TX\_RDI. Likewise, an AIS-L condition can be forced by asserting EWIS\_TXCTRL2.FRC\_TX\_AISL. If both conditions are forced, the AIS-L value is transmitted.

In the receive direction, the RDI-L alarm (K2[6:8] = 110, using SONET nomenclature) and the AIS-L alarm (K2[6:8] = 111, using SONET nomenclature) are not asserted until the condition persists for a programmable number of contiguous frames. This value is programmable at EWIS\_RX\_ERR\_FRC1.APS\_THRES and is typically set to values of 5 or 10. The AIS-L is detected by the receiver after the programmable number of frames is received, and results in the reporting of AIS-P.

The WIS standard defines WIS\_STAT3.RDIL and WIS\_STAT3.AISL as a read only, latch-high register, so a read of a one in this register indicates that an error condition occurred since the last read. A second read of the register provides the current status of the event as to whether the alarm is currently asserted. EWIS\_INTR\_PEND1.RDIL\_PEND and EWIS\_INTR\_PEND1.AISL\_PEND assert whenever the RDI-L or AIS-L state changes (assert or deassert). These interrupts have associated mask enable bits, EWIS\_INTR\_MASKA\_1.RDIL\_MASKA, EWIS\_INTR\_MASKB\_1.RDIL\_MASKB, EWIS\_INTR\_MASKA\_1.AISL\_MASKA and EWIS\_INTR\_MASKB\_1.AISL\_MASKB, which, if enabled, propagate an interrupt to the WIS\_INTA/B pins.

For test purposes, the VSC8257-01 device can induce an RDI-L condition in the receive direction independent of the received K2 value by asserting EWIS\_RX\_ERR\_FRC1.FRC\_RX\_RDIL. Likewise, an

AIS-L condition can be forced in the receive direction by asserting EWIS\_RX\_ERR\_FRC1.FRC\_RX\_AISL.

### 3.3.16.3 Line Data Communications Channel (D4 to D12)

The WIS standard does not support Line Data Communications Channel (L-DCC) octets (D4-D12) and recommends transmitting 0x00 within these octets. The D4-D12 transmitted values can be programmed in registers EWIS\_TX\_D4\_D5 - EWIS\_TX\_D12\_Z4. The register defaults are all 0x00. The receive L-DCC octets are only accessible through the ROSI port.

### 3.3.16.4 STS-1/N Line Remote Error Indication (M0 and M1)

The M0 and M1 octets are used for back reporting the number of B2 errors received, known as remote error indication (REI-L). The value in this octet comes from the B2 error FIFO, as discussed with the B2 octet. The WIS standard does not support the M0 octet and recommends transmitting 0x00 in place of the M0 octet. However, the WIS standard supports the M1 octet in accordance with T1.416.

Two methods for back-reporting exist and are controlled by EWIS\_TXCTRL2.SDH\_TX\_MODE. Because a single frame can contain up to 1536 B2 errors while the M1 byte alone can only back report a maximum of 255 errors, a discrepancy exists. When G707\_2000\_REIL is deasserted, only the M1 byte is used and a maximum of 255 errors are back-reported. When G707\_2000\_REIL is asserted, two octets per frame are used for back reporting, the M1 octet and the M0 octet (not the first STS-1 octet, but the second STS-1 octet). In this mode, a total of 1536 errors can be back-reported per frame.

In the receive direction the VSC8257-01 device detects and accumulates errors according to the EWIS\_MODE\_CTRL.REI\_MODE setting. The VSC8257-01 device deviates from the G.707 standard by not interpreting REI-L values greater than 1536 as zero. The WIS standard defines a 32-bit REI-L counter in registers WIS\_REIL\_CNT1 and WIS\_REIL\_CNT0. This counter is non-saturating and so rolls over after its maximum count. The counter is cleared only on device reset.

An additional 32-bit REI-L counter is provided in registers EWIS\_REIL\_CNT1 and EWIS\_REIL\_CNT0, which is a saturating counter and is latched and cleared based upon a PMTICK event. Errors are accumulated since the previous PMTICK event. When the counter is nonzero, the EWIS\_INTR\_PEND2.REIL\_NZ\_PEND event register is asserted until read. A non-latch high version of this event EWIS\_INTR\_STAT2.REIL\_NZ\_STAT is also available. This event can propagate an interrupt to either WIS\_INTA or WIS\_INTB based upon mask enable bits EWIS\_INTR\_MASKA\_2.REIL\_NZ\_MASKA and EWIS\_INTR\_MASKB\_2.REIL\_NZ\_MASKB.

The REIL\_ERR\_CNT can optionally be configured to increment on a block count basis, a maximum increment of 1 per errored frame regardless of the number of errors received. This mode is enabled by asserting EWIS\_CNT\_CFG.REIL\_BLK\_MODE.

### 3.3.16.5 Synchronization Messaging (S1)

The S1 octet carries the synchronization status message and provides synchronization quality measures of the transmission link in the least significant 4 bits. The WIS standard does not support the S1 octet and requires the transmission of a 0x0F within the S1 octet. A value other than 0x0F can be programmed in TX\_S1 (2xE61F).

### 3.3.16.6 Reserved for Line Growth (Z1 and Z2)

The WIS standard does not support the Z1 or Z2 octets and requires the transmission of 0x00 in their locations. Different Z1 and Z2 values can be transmitted by programming the values at EWIS\_TX\_S1\_Z1.TX\_Z1 and EWIS\_TX\_Z2\_E2.TX\_Z2 respectively.

### 3.3.16.7 Orderwire (E2)

The WIS standard does not support the E2 octet and recommends transmitting 0x00 in place of the E2 octet. A value other than 0x00 can be transmitted by programming the intended value at EWIS\_TX\_Z2\_E2.TX\_E2.

### 3.3.17 SPE Pointer

The H1 and H2 octets are used as a pointer within the SONET/SDH frame to locate the beginning of the path overhead and the beginning of the synchronous payload envelope (SPE). Within SONET/SDH the SPE can begin anywhere within the payload area, however IEEE 802.3ae specifies that a transmitted

SPE must always be positioned solely within a single SONET/SDH frame. The constant pointer value of 522 decimal (0x20A) must be contained in the first channel's H1 and H2 octets. Together these conditions result in the H1 and H2 octets being 0x62 and 0x0A, respectively. These are the default values of EWIS\_TX\_C2\_H1.TX\_H1 and EWIS\_TX\_H2\_H3.TX\_H2. Programming these registers with alternate values does not alter the positioning of the SPE, but it might induce a loss of pointer (LOP-P) at the far-end, or at least prevent the far-end from extracting the proper payload. Furthermore, the WIS standard specifies the frame structure be a concatenated payload. For this reason, the H1 and H2 octets in channels 2 through 192 contain the concatenation indicator.

The VSC8257-01 device supports forcing the loss of pointer (LOP-P) and path alarm indication signal (AIS-P) state.

The WIS standard specifies that a 0x00 be transmitted in the H3 octet. An alternate value can be transmitted by programming EWIS\_TX\_H2\_H3.TX\_H3.

The WIS specification does not limit the pointer position within the receive SONET/SDH frame to allow interoperability to other SONET/SDH equipment. In addition to supporting the required SONET pointer rules, the VSC8257-01 device pointer interpreter optionally supports SDH pointers. This is selectable using the EWIS\_MODE\_CTRL.RX\_SS\_MODE bit. The following table shows the differences between SONET and SDH modes.

**Table 8 • SONET/SDH Pointer Mode Difference**

SONET	SDH
SS bits are ignored by the device pointer interpreter and not used.	SS bits are set to 10 and are checked by the device pointer interpreter to determine the pointer type
All 192 bytes of H1 and H2 are checked by the pointer interpreter to determine the pointer type.	The first 64 bytes are checked by the device pointer interpreter to determine the pointer type (first Au-4 of an AU-4-64c)
Uses '8 out of 10' GR-253-core objective increment/decrement rule	Uses majority detect increment/decrement rule

The H1 and H2 octets combine to form a word with several fields as described in the following section.

### 3.3.17.1 Bit Designations within Payload Pointer

The N bits [15:12] carry a new data flag (NDF). This mechanism allows an arbitrary change in the location of the payload. NDF is indicated by at least three out of the four N bits matching the code '1001' (NDF enabled). Normal operation is indicated by three out of the four N bits matching the code '0110' (normal NDF).

The last ten bits of the pointer word (D bits and I bits) carry the pointer value. The pointer value has a range from 0 to 782 that indicates the offset between the first byte after the H3 byte and the first byte of the SPE.

The SS bits are located in bits 11 and 10 and are unused in SONET mode. In SDH mode, these bits are compared with pattern '10', and the pointer is considered invalid if it does not match.

Because the VSC8257-01 device only supports concatenated frames, only the first pair of bytes (H1, H2) are called the primary pointer and have a normal format. The rest of the H1/H2 bytes contain the concatenation indication (CI). The format for the CI is NDF enabled with a pointer value of all ones.

**Table 9 • 16-bit Designations within the Payload Pointer**

H1					H2										
15	14	13	12	11	10	9	8	7	6	5	4	3	2	1	0
N	N	N	N	S	S	I	D	I	D	I	D	I	D	I	D

### 3.3.17.2 Pointer Types

The VSC8257-01 device supports five different pointer types as described in the following table. A normal pointer indicates the current pointer, a new data flag indicates a new pointer location, and an AIS pointer indicates AIS. The pointer increment and pointer decrement mechanism adjusts the frequency offset between the frame overhead and SPE. A pointer increment is indicated by a normal NDF that has the currently accepted pointer with the I bits inverted. A pointer decrement is indicated by a normal NDF that has the currently accepted pointer with D bits inverted.

**Table 10 • H1/H2 Pointer Types**

Pointer Type	nnnn Value	Pointer Value	SS Bits
Normal	Three out of the four bits matching 0110	0 to 782	Matching in SDH mode, ignored in SONET mode
New Data Flag (NDF)	Three out of the four bits matching 1001	0 to 782	Matching in SDH mode, ignored in SONET mode
AIS Pointer	1111	1111 1111 11	11
Pointer increment	Three out of the four bits matching 0110	Current pointer with I bits inverted	Matching in SDH mode, ignored in SONET mode
Pointer decrement	Three out of the four bits matching 0110	Current pointer with D bit inverted	Matching in SDH mode, ignored in SONET mode

The following table lists the concatenation types.

**Table 11 • Concatenation Types**

Pointer Type	nnnn Value	Pointer Value	SS Bits
Normal	Three out of the four bits matching 0110	1111 1111 11	Matching in SDH mode, ignored in SONET mode
AIS	Pointer value, nnnn value, and SS bits are the same as the AIS pointer.		
Invalid	Any other concatenation, other than normal CI, or AIS CI		

### 3.3.17.3 Pointer Adjustment Rule

The pointer interpreter adjusts the current pointer value according to rules listed in Section 9.1.6 of ANSI T1.105-1995. In addition, no increment/decrement is accepted for at least three frames following an increment/decrement or NDF operation.

### 3.3.17.4 Pointer Increment/Decrement Majority Rules

In SONET mode, the pointer interpreter uses more restrictive GR-253-CORE objective rules, as follows:

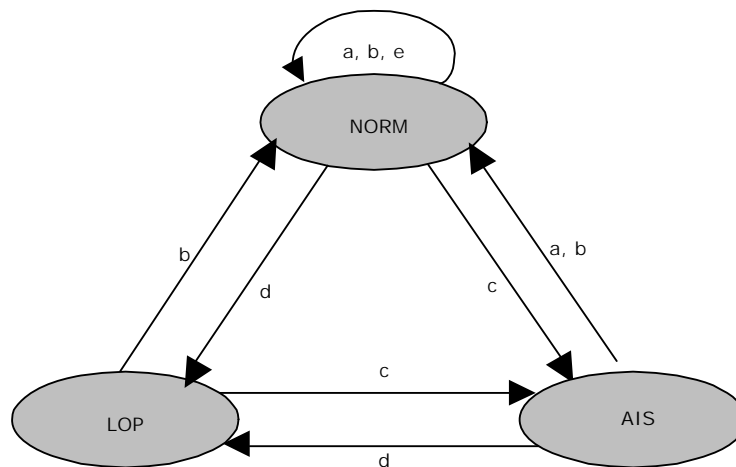
- An increment is indicated by eight or more bits matching non-inverted D bits and inverted I bits.
- A decrement is indicated by eight or more bits matching non-inverted I bits and inverted D bits.

In SDH mode, the majority rules are:

- An increment is indicated by three or more inverted I bits and two or fewer inverted D bits.
- A decrement is indicated by three or more inverted D bits and two or fewer inverted I bits.
- If three or more D bits are inverted and three or more I bits are inverted, no action is taken.

### 3.3.17.5 Pointer Interpretation States

The pointer interpreter algorithm for state transitions can be modeled as a finite state machine with three states, as shown in the following figure. The three states are normal (NORM), loss of pointer (LOP), and alarm indication state (AIS).

**Figure 14 • Pointer Interpretation States Diagram**

The following table lists the pointer interpretation state transitions.

**Table 12 • Pointer Interpreter State Transitions**

Transitions	State	Descriptions	Required Persistence
a	NORM to NORM	<H1><H2> = <EEEESSPP><PPPPPP PP>, NDF enabled with pointer in range (0 to 782). SS bit match (if enabled).	1 Frame
b	NORM to NORM LOP to NORM AIS to NORM	<H1><H2>=<DDDDSSPP><PPPPP PPP>. NDF disabled (NORM pointer) with the same pointer value in range (0 to 782). SS bit match (if enabled).	3 Frames
c	NORM to AIS LOP to AIS	<H1><H2>=<11111111><11111111>. AIS pointer (0xFFFF).	3 Frames
d	NORM to LOP AIS to LOP	Anything other than transitions b and c or NDF enabled (transition a), or AIS pointer when not in AIS state, or NORM pointer when not in NORM state, or NORM pointer with pointer value not equal to current, or increment/decrement, or CONC pointer, or SS bit mismatch (if comparison is enabled).	8 Frames
e	Justification	Valid increment or decrement indication	1 Frame

### 3.3.17.6 Valid Pointer Definition for Interpreter State

During an AIS state, only an AIS pointer is a valid pointer. In NORM state, several definitions of “valid pointer” for purpose of LOP detection are possible according to GR-253-CORE. The VSC8257-01 device follows the GR-253-CORE intended definition, but adds a single normal pointer that exactly matches the current valid pointer value.

Any change in the AIS state is reflected in the alarm bit WIS\_STAT3.AISP. This latch-high register reports both the event and status information in consecutive reads. The EWIS\_INTR\_PEND1.AISP\_PEND bit remains asserted until read. This event can propagate an interrupt to either WIS\_INTA or WIS\_INTB, based on mask enable bits EWIS\_INTR\_MASKA\_1.AISP\_MASKA and EWIS\_INTR\_MASKB\_1.AISP\_MASKB.

Similarly, any change in the LOP state is reflected in the alarm bit WIS\_STAT3.LOPP. This latch-high register reports both the event and status information in consecutive reads. The EWIS\_INTR\_PEND1.LOPP\_PEND bit remains asserted until read. This event can propagate an interrupt to either WIS\_INTA or WIS\_INTB, based upon the mask enable bits EWIS\_INTR\_MASKA\_1.LOPP\_MASKA and EWIS\_INTR\_MASKB\_1.LOPP\_MASKB.

### 3.3.18 Path Overhead

The path overhead portion of the SONET/SDH frame supports an end-to-end trace identifier, a payload parity check, a payload type indicator, a status indicator, and a user channel. The following table lists each of the octets, including their function.

**Note:** The VSC8257-01 device provides a mechanism to transmit a static value as programmed by the MDIO interface. However, by definition, MDIO is not fast enough to alter the octet on a frame-by-frame basis. Extended WIS TOSI and ROSI do not support path overhead.

**Table 13 • STS Path Overhead Octets**

Overhead Octet	Function	IEEE 802.3ae WIS Use	Recommended Value	WIS Extension
J1	Path trace message	Specified value	See “Overhead Octet (J1),” below.	A 1-, 16-, or 64-byte trace message can be sent using registers (EWIS_TX_MSGLEN.J1_TXLEN, WIS_Tx_J1_Octets_1_0-WIS_Tx_J1_Octets_15_14, and EWIS_Tx_J1_Octets_17_16-EWIS_Tx_J1_Octets_63_62); and received using registers (EWIS_RX_MSGLEN.J1_RX_LEN, WIS_Rx_J1_Octets_1_0-WIS_Rx_J1_Octets_15_14, EWIS_Rx_J1_Octets_17_16-EWIS_Rx_J1_Octets_63_62). TOSI and ROSI access.
B3	Path error monitoring (path BIP-8)	Supported	Bit interleaved parity - 8 bits as specified in T1.416	Both SONET and SDH mode B3 calculation is supported.
C2	Path signal label	Specified value	0x1A	Register (EWIS_TX_C2_H1.C2). Supports persistency and mismatch detection (EWIS_MODE_CTRL.Cs_EXP).
G1	Path status	Supported	As specified in T1.416	Ability to select between RDI-P and ERDI-P formats.
F2	Path user channel	Unsupported	0x00	Register (EWIS_TX_K2_F2.TX_F2).
H4	Multiframe indicator	Unsupported	0x00	Register (WEIS_TX_D6_H4.TX_H4).
Z3 - Z4	Reserved for path growth	Unsupported	0x00	Register (EWIS_TX_D9_Z3.TX_Z3, EWIS_TX_D12_Z4.TX_Z4).
N1	Path error monitoring (path BIP-8)	Unsupported	0x00	Register (WEIS_TX_N1.TX_N1). TOSI and ROSI access.

#### 3.3.18.1 Overhead Octet (J1)

The J1 transmitted octet contains a 16-octet repeating path trace message whose contents are defined in WIS Tx J1s (WIS\_Tx\_J1\_Octets\_1\_0- WIS\_Tx\_J1\_Octets\_15\_14). If no active message is being broadcast, a default path trace message is transmitted, consisting of 15 octets of zeros and a header octet formatted according to Section 5 of ANSI T1.269-2000. The header octet for the 15- octets of zero is 0x89. The default values of WIS Tx J1s do not contain the 0x89 value of the header octet, thus software must write this value.

The J1 octet in the receive direction by default is assumed to be carrying a 16-octet continuously repeating path trace message. The message is extracted from the incoming WIS frames and presented

in WIS Rx J1s (WIS\_Rx\_J1\_Octets\_1\_0- WIS\_Rx\_J1\_Octets\_15\_14). The WIS receive process does not delineate the message boundaries, thus the message might appear rotated between new frame alignment events.

The VSC8257-01 device supports two alternate message types, a single repeating octet and a 64-octet message. The message type can be independently selected for the transmit and receive direction. The transmit direction is configured using EWIS\_TX\_MSGLEN.J1\_TXLEN while EWIS\_RX\_MSGLEN.J1\_RX\_LEN configures the receive path.

When the transmit direction is configured for a 64-octet message, the first 16 octets are programmed in WIS\_Tx\_J1\_Octets\_1\_0-WIS\_Tx\_J1\_Octets\_15\_14 while the 48 remaining octets are programmed in EWIS\_Tx\_J1\_Octets\_17\_16- EWIS\_Tx\_J1\_Octets\_63\_62. Likewise, the first 16-octets of the receive message are stored in J1\_RXMSG (WIS\_Rx\_J1\_Octets\_1\_0-WIS\_Rx\_J1\_Octets\_15\_14), while the other 48 octets are stored in EWIS\_Rx\_J1\_Octets\_17\_16-EWIS\_Rx\_J1\_Octets\_63\_62. The receive message is updated every 125  $\mu$ s with the recently received octet. Any persistence or message matching is expected to take place within the station manager.

### 3.3.18.2 STS Path Error Monitoring (B3)

The B3 octet is a bit interleaved parity-8 (BIP-8) code, using even parity, calculated over the previous STS-192c SPE before scrambling. The computed BIP-8 is placed in the B3 byte of the following frame before scrambling.

In the receive direction, the incoming frame is processed and a B3 octet is calculated over the received frame. The calculated value is then compared with the B3 value received in the following frame. The difference between the calculated and received octets are accumulated in block (maximum increment of 1 per errored frame) fashion into a B3 error register, WIS\_B3\_CNT. This counter is non-saturating and so rolls over. The counter is cleared upon a device reset.

An additional 32-bit B3 error counter is provided at B3\_ERR\_CNT (EWIS\_B3\_ERR\_CNT1 and EWIS\_B3\_ERR\_CNT0), a saturating counter that is latched and cleared based upon a PMTICK event. Errors are accumulated starting from the previous PMTICK event. When the counter is nonzero, the EWIS\_INTR\_PEND2.B3\_NZ\_PEND event register is asserted until read. A non-latch high version of this event EWIS\_INTR\_STAT2.B3\_NZ\_STAT is also available. This event may propagate an interrupt to either WIS\_INTA or WIS\_INTB, based on the mask enable bits EWIS\_INTR\_MASKA\_2.B3\_NZ\_MASKA and EWIS\_INTR\_MASKB\_2.B3\_NZ\_MASKB.

The B3\_ERR\_CNT may optionally be configured to increment on a block count basis, a maximum increment of 1 per errored frame regardless of the number of errors received. The EWIS\_CNT\_CFG.B3\_BLK\_MODE control bit, if asserted, places the B3\_ERR\_CNT counter in block increment mode.

It is possible that two sets of B3 bytes (from two SONET/SDH frames) are received by the Rx WIS logic in a period of time when only one G1 octet is transmitted. In this situation, one of the two B3 error counts delivered to the Tx WIS logic is discarded. This situation occurs when the receive data rate is faster than the transmit data rate. Similarly, when the transmit data rate is faster than the receive data rate, a B3 error count is not available for REI-P insertion into the G1 octets of the transmitted SONET/ SDH frame. A value of zero is transmitted in this case. This behavior is achieved by using a FIFO to transfer the detected B3 error count from the receive to transmit domains.

A FIFO overflow or underflow condition is not considered an error. A FIFO overflow or underflow eventually occurs, unless the transmit and receive interfaces are running at the same average data rate. Because the received and transmitted frames can differ by, at most, 40 ppm ( $\pm 20$  ppm) and still meet the industry standards, this “slip” can happen no more often than once every 3.1 seconds.

### 3.3.18.3 STS Path Signal Label and Path Label Mismatch (C2)

The C2 octet contains a value intended to describe the type of payload carried within the SONET/SDH frame. The WIS standard calls for a 0x1A to be transmitted. This is the default value of EWIS\_TX\_C2\_H1.TX\_C2.

As specified in T1.416, a path label mismatch (PLM-P), register WIS\_STAT3.PLMP, event occurs when the C2 octet in five consecutive frames contain a value other than the expected one. The expected value is set in EWIS\_MODE\_CTRL.C2\_EXP, whose default value 0x1A is compliant with the WIS standard.



When a value of 0x00 is accepted (received for five or more consecutive frames) the unequipped path pending, EWIS\_INTR\_PEND2.UNEQP\_PEND, event is asserted until read. A non-latch high version of this event EWIS\_INTR\_STAT2.UNEQP\_STAT is also available. This event can propagate an interrupt to either WIS\_INTA or WIS\_INTB, based on the mask enable bits EWIS\_INTR\_MASKA\_2.UNEQP\_MASKA and EWIS\_INTR\_MASKB\_2.UNEQP\_MASKB.

If the accepted value is not an unequipped label (0x00) and it differs from the programmed expected value, EWIS\_MODE\_CTRL.C2\_EXP, then a path label mismatch, WIS\_STAT3.PLMP, is asserted. Similarly the EWIS\_INTR\_PEND1.PLMP\_PEND event is asserted until read. This event can propagate an interrupt to either WIS\_INTA or WIS\_INTB, based on the mask enable bits EWIS\_INTR\_MASKA\_1.PLMP\_MASKA and EWIS\_INTR\_MASKB\_1.PLMP\_MASKB.

Although PLMP is not a path level defect, it does cause a change in the setting of one of the ERDI-P codes.

### 3.3.18.4 Remote Path Error Indication (G1)

The most significant four bits of the G1 octet are used for back reporting the number of B3 block errors received at the near-end. This is typically known as path remote error indication (REI-P). The value in this octet comes from the B3 error FIFO. The WIS standard defines a 16-bit REI-P counter, register WIS\_REIP\_CNT. The WIS standard defines this counter to operate as a block counter as opposed to an individual errored bit counter. This counter is non-saturating and so rolls over after its maximum count. The counter does not clear upon a read, but instead only upon reset as defined in the WIS specification. When the counter is nonzero, the EWIS\_INTR\_PEND2.REIP\_PEND event register is asserted until read. A non-latch high version of this event EWIS\_INTR\_STAT2.REIP\_STAT is also available. This event may propagate an interrupt to either WIS\_INTA or WIS\_INTB, based on the mask enable bits EWIS\_INTR\_MASKA\_2.REIP\_MASKA and EWIS\_INTR\_MASKB\_2.REIP\_MASKB, respectively.

An additional 32-bit REI-P counter is provided at REIP\_ERR\_CNT (EWIS\_REIP\_CNT1 and EWIS\_REIP\_CNT0) which is a saturating counter and is latched and cleared based upon a PMTICK event. Errors are accumulated since the previous PMTICK event. When the counter is nonzero, the EWIS\_INTR\_PEND2.REIP\_NZ\_PEND event register is asserted until read. A non-latch high version of this event EWIS\_INTR\_STAT2.REIP\_NZ\_STAT is also available. This event may propagate an interrupt to either WIS\_INTA or WIS\_INTB, based on the mask enable bits EWIS\_INTR\_MASKA\_2.REIP\_NZ\_MASKA and EWIS\_INTR\_MASKB\_2.REIP\_NZ\_MASKB, respectively.

The REIP\_ERR\_CNT may optionally be configured to increment on a block count basis, a maximum increment of 1 per errored frame regardless of the number of errors received. This mode is enabled by asserting EWIS\_CNT\_CFG.REIP\_BLK\_MODE.

### 3.3.18.5 Path Status (G1)

In addition to back-reporting the far-end B3 BIP-8 error count, the G1 octet carries status information from the far-end device known as path remote defect indicator (RDI-P). T1.416 allows either support of 1-bit RDI-P or 3-bit ERDI-P, but indicates ERDI-P is preferred. The VSC8257-01 device supports both modes and may be independently configured for the Rx and Tx directions by configuring EWIS\_MODE\_CTRL.RX\_ERDI\_MODE and EWIS\_TXCTRL2.ERDI\_TX\_MODE. ERDI-P is the default for both directions.

**Table 14 • Path Status (G1) Byte for RDI-P Mode**

G1 REI (B3)				RDI-P	Reserved	Spare	
1	2	3	4	5	6	7	8
Remote Error Indicator count from B3 (0-8 value)				Remote Defect Indicator	Set to 00 by transmitter		Ignored by receiver

The following table lists the Path Status (G1) byte for ERDI-P mode.

**Table 15 • Path Status (G1) Byte for ERDI-P Mode**

G1 REI (B3)				ERDI-P			Spare
1	2	3	4	5	6	7	8
Remote Error Indicator count from B3 (0-8 value)				Enhanced Remote Defect Indicator (See next table)			Ignored by receiver

Enhanced RDI is defined for SONET-based systems as listed in GR-253-CORE (Issue 3), reproduced here in the following table, and as a possible enhancement of SDH-based systems (G.707/Y.1322 (10/2000) Appendix VII (not an integral part of that recommendation)). The following table lists the RDI-P and ERDI-P Bit Settings and Interpretations.

**Table 16 • RDI-P and ERDI-P Bit Settings and Interpretations**

G1 Bits 5, 6, and 7	Priority of ERDI-P Codes	Trigger	Interpretation
000/011	Not applicable	No defects	No RDI-P defect
100/111	Not applicable	Path alarm indication signal (AIS-P). The remote device sends all ones for H1, H2, H3, and the entire STS SPE. Path loss of pointer (LOP-P).	One-bit RDI-P defect
001	4	No defects	No ERDI-P defect
010	3	Path label mismatch (PLM-P). Path loss of code group delineation (LCD-P)	ERDI-P payload defect
101	1	Path alarm indication signal (AIS-P). The remote device sends all ones for H1, H2, H3 and entire STS SPE. Path loss of pointer (LOP-P).	ERDI-P server defect
110	2	Path unequipped (UNEQ-P). The received C2 byte is 0x00. Path trace identifier mismatch (TIM-P). This error is not automatically generated, but can be forced using MDIO.	ERDI-P connectivity defect

In the receive direction, with `EWIS_MODE_CTRL.RX_ERDI_MODE = 0`, an RDI-P defect is the occurrence of the RDI-P signal in ten contiguous frames. An RDI-P defect terminates when no RDI-P signal is detected in ten contiguous frames. An RDI-P event asserts `EWIS_INTR_PEND2.FERDIP_PEND` until read. A non-latch high version of the far-end RDI-P status can be found in `EWIS_INTR_STAT2.FERDIP_STAT`. This event may propagate an interrupt to either `WIS_INTA` or `WIS_INTB`, based on the mask enable bits `EWIS_INTR_MASKA_2.FERDIP_MASKA` and `EWIS_INTR_MASKB_2.FERDIP_MASKB`.

When `EWIS_MODE_CTRL.RX_ERDI_MODE = 1`, an ERDI-P defect is the occurrence of any one of three ERDI-P signals in ten contiguous frames. An ERDI-P defect terminates when no ERDI-P signal is detected in ten contiguous frames.

The 010 code triggers the latch high register bit `WIS_STAT3.FEPLMP_LCDP`. It also asserts `EWIS_INTR_PEND1.FEPLMP_LCDP_PEND` until read. This event may propagate an interrupt to either

WIS\_INTA or WIS\_INTB, based on the mask enable bits EWIS\_INTR\_MASKA\_1.FEPLMP\_LCDP\_MASKA and EWIS\_INTR\_MASKB\_1.FEPLMP\_LCDP\_MASKB, respectively.

The 101 code triggers the latch high register bit WIS\_STAT3.FEAISP\_LOPP. It also asserts EWIS\_INTR\_PEND1.FEAISP\_LOPP\_PEND until read. This event may propagate an interrupt to either WIS\_INTA or WIS\_INTB, based on the mask enable bits EWIS\_INTR\_MASKA\_1.FEAISP\_LOPP\_MASKA and EWIS\_INTR\_MASKB\_1.FEAISP\_LOPP\_MASKB, respectively.

The 110 code asserts the EWIS\_INTR\_PEND2.FEUNEQP\_PEND until read. A non-latch- high version of this register EWIS\_INTR\_STAT2.FEUNEQP\_STAT is also available. This event may propagate an interrupt to either WIS\_INTA or WIS\_INTB, based on the mask enable bits EWIS\_INTR\_MASKA\_2.FERDIP\_MASKA and EWIS\_INTR\_MASKB\_2.FERDIP\_MASKB, respectively.

### 3.3.18.6 Path User Channel (F2)

The WIS standard does not support the F2 octet and recommends transmitting 0x00 in place of the F2 octet. A value other than 0x00 may be transmitted by programming the intended value at EWIS\_TX\_K2\_F2.TX\_F2.

### 3.3.18.7 Multi-frame Indicator (H4)

The WIS standard does not support the H4 multi-frame octet and recommends transmitting 0x00 in place of the H4 octet. A value other than 0x00 may be transmitted by programming the intended value at EWIS\_TX\_D6\_H4.TX\_H4.

### 3.3.18.8 Reserved for Path Growth (Z3-Z4)

The WIS standard does not support the Z3-Z4 octets and recommends transmitting 0x00 in their place. A value other than 0x00 may be transmitted by programming the intended value at EWIS\_TX\_D9\_Z3.TX\_Z3 and EWIS\_TX\_D12\_Z4.TX\_Z4 respectively.

### 3.3.18.9 Tandem Connection Maintenance/Path Data Channel (N1)

The WIS standard does not support the N1 octet and recommends transmitting 0x00 in place of the N1 octet. A value other than 0x00 may be transmitted by programming the intended value at EWIS\_TX\_N1.TX\_N1.

### 3.3.18.10 Loss of Code Group Delineation

After the overhead is stripped, the payload is passed to the PCS. If the PCS block loses synchronization and cannot delineate valid code groups, the PCS passes a loss of code group delineation (LCD-P) alarm to the WIS. This alarm triggers the latch high register bit WIS\_STAT3.LCDP. It also asserts EWIS\_INTR\_PEND1.LCDP\_PEND until read. This event may propagate an interrupt to either WIS\_INTA or WIS\_INTB, based on the mask enable bits EWIS\_INTR\_MASKA\_1.LCDP\_MASKA and EWIS\_INTR\_MASKB\_1.LCDP\_MASKB, respectively.

The WIS specification calls for a LCD-P defect persisting continuously for more than 3 ms to be back reported to the far-end. Upon device reset, a LCD-P is back reported until the PCS signals that valid code groups are being delineated. The LCD-P defect deasserts (and is not back-reported) after the condition is absent continuously for at least 1 ms.

### 3.3.18.11 Reading Statistical Counters

The VSC8257-01 device contains several counters that may be read using the MDIO interface. For each error count, there are two sets of counters. The first set is the standard WIS counter implemented according to IEEE 802.3ae, and the second set is for statistical counts using PMTICK.

To read the IEEE 802.3ae counters, the station manager must read the most significant register of the 32-bit counter first. This read action latches the internal error counter value into the MDIO readable registers. A subsequent read of the least significant register does not latch new values, but returns the value latched at the time of the most significant register read.

It may be difficult to get a clear picture of the timeframes in which errors were received because the IEEE 802.3ae counters are independently latched. The PMTICK counters are all latched together, thereby

providing a complete snapshot in time. When PMTICK is asserted, the internal error counter values are copied into their associated registers and the internal counters are reset.

There are three methods of asserting PMTICK:

- The station manager may asynchronously assert EWIS\_PMTICK\_CTRL.PMTICK\_FRC to latch the values at a given time, regardless of the EWIS\_PMTICK\_CTRL.PMTICK\_ENA setting.
- The device may be configured to latch and clear the statistical counters at a periodic interval as determined by the timer (count) value in EWIS\_PMTICK\_CTRL.PMTICK\_DUR. In this mode the EWIS\_PMTICK\_CTRL.PMTICK\_SRC must be configured for internal mode and the EWIS\_PMTICK\_CTRL.PMTICK\_ENA bit must be asserted. The receive path clock is used to drive the PMTICK counter, thus the periodicity of the timer can vary during times of loss of lock and loss of frame.
- The device may be configured to latch and clear the statistical counters at the occurrence of a rising edge detected at a GPIO pin configured as a PMTICK input pin. In this mode the EWIS\_PMTICK\_CTRL.PMTICK\_SRC bit must be deasserted, and the EWIS\_PMTICK\_CTRL.PMTICK\_ENA must be asserted. Corresponding GPIO must be configured as the PMTICK input pin.

Regardless of EWIS\_PMTICK\_CTRL.PMTICK\_SRC, when the PMTICK event occurs the EWIS\_INTR\_PEND2.PMTICK\_PEND is asserted until read. This event may propagate an interrupt to either WIS\_INTA or WIS\_INTB, based on the mask enable bits EWIS\_INTR\_MASKA\_2.PMTICK\_MASKA and EWIS\_INTR\_MASKB\_2.PMTICK\_MASKB, respectively.

Given the size of the error counters and the maximum allowable error counts per frame, care must be taken in the frequency of polling the registers to ensure accurate values. All PMTICK counters saturate at their maximum values.

**Table 17 • PMTICK Counters**

Counter Name	Description	Registers	Maximum Increase Counter per Frame	Maximum Increase Counter per Second	Time Until Overflow
B1_ERR_CNT	B1 section error count	EWIS_B1_ERR_CNT1 EWIS_B1_ERR_CNT0	8	64,000	67,109
B2_ERR_CNT	B2 line error count	EWIS_B2_ERR_CNT1 EWIS_B2_ERR_CNT0	1536	12,288,000	350
B3_ERR_CNT	B3 path error count	EWIS_B3_ERR_CNT1 EWIS_B3_ERR_CNT0	8	64,000	67,109
EWIS_REIP_CNT	Far-end B3 path error count	EWIS_REIP_CNT1 EWIS_REIP_CNT0	8	64,000	67,109
EWIS_REIL_CNT	Far-end B2 line error count	EWIS_REIL_CNT1 EWIS_REIL_CNT0	1536	12,288,000	350

Both individual and block mode accumulation of B1, B2, and B3 error indications are supported and selectable using the control bits EWIS\_CNT\_CFG.B1\_BLK\_MODE, EWIS\_CNT\_CFG.B2\_BLK\_MODE, and EWIS\_CNT\_CFG.B3\_BLK\_MODE. In individual accumulation mode, 0, the counter is incremented for each bit mismatch between the calculated B1, B2, and/or B3 error and the extracted B1, B2, and/or B3. In block accumulation mode, 1, the counter is incremented only once for any nonzero number of bit mismatches between the calculated B1, B2, and/or B3 and the extracted B1, B2, and/or B3 (maximum of one error per frame).

### 3.3.18.12 Defects and Anomalies

All defects and anomalies listed in the following table can be forced and masked by the user. The VSC8257-01 device does not automatically generate TIM-P, but does support forcing defects using MDIO.

**Table 18 • Defects and Anomalies**

Defect or Anomaly	Description	Type	Force Bit	Status Bit
Far-end PLM-P or LCD-P	These two errors are indistinguishable when reported by the far end through the G1 octet (ERDI-P), because the far end reports both PLM-P and LCD-P with the same error code.	Far-end defect	EWIS_RX_ERR _FRC2.FRC_RX _FE_PLMP	WIS_STAT3.F EPLMP_LCD P
Far-end AIS-P or LOP-P	These two errors are indistinguishable when reported by the far end through the G1 octet (ERDI-P), because the far end reports both AIS-P and LOP-P with the same error code.	Far-end defect	EWIS_RX_ERR _FRC2.FRC_R X_FE_AISP	WIS_STAT3.F EAISP_LOPP
PLM-P	Path Label Mismatch. The detection and reporting of the PLM-P defect follows section 7.5 of ANSI T1.416.1999	Near-end defect; propagated to PCS	EWIS_RX_ERR _FRC2.FRC_R X_PLMP	WIS_STAT3.P LMP
AIS-L	Loss Alarm Indication Signal. Generated on LOPC, LOS, LOF, if enabled by EWIS_RXTX_CTRL.RXAISL_ON_LOPC, EWIS_RXTX_CTRL.RXAISL_ON_LOS, EWIS_RXTX_CTRL.RXAISL_ON_LOF, or when forced by user.	Near-end defect	The AIS-L defect is only processed and reported by the WIS Receive process; it is never transmitted by the WIS Transmit process, in accordance with IEEE 802.3ae.	EWIS_RX_E RR_FRC1.FR C_RX_AISL/ WIS_STAT3.A ISL
AIS-P	Path Alarm Indication Signal.	Near-end defect; propagated to PCS	EWIS_RX_ERR _FRC1.FRC_R X_AISP	WIS_STAT3.A ISP
LOP-P	Path Loss of Pointer. Nine consecutive invalid pointers result in loss of pointer detection.	Near-end defect; propagated to PCS	EWIS_RX_ERR _FRC1.FRC_R X_LOP	WIS_STAT3.L OPP
LCD-P	Path Loss of Code Group Delineation. This is also reported to the far end if it persists for at least 3 ms. See <a href="#">Table 16</a> , page 33.	Near-end defect	EWIS_RX_ERR _FRC2.FRC_LC DP	WIS- STAT3.LCDP
LOPC	Loss of Optical Carrier Alarm. This is an input from the XFP module's loss of signal output. The polarity can be inverted for use with other module types. This defect can be used independently, or in place of LOS.	Near-end defect	EWIS_RX_ERR _FRC1.FRC_L OPC	WIS- STAT3.LOPC _STAT

**Table 18 • Defects and Anomalies (continued)**

Defect or Anomaly	Description	Type	Force Bit	Status Bit
LOS	Loss of Signal. The PMA circuitry detects an LOS defect if the input signal falls below the assert threshold. When a PMA LOS is declared, the framer is held in reset to prevent it from looking for a frame boundary.	Near-end defect	EWIS_RX_ERR _FRC1.FRC_L OS	WIS- STAT3.LOS
SEF	Severely Errored Frame. Generated when the device cannot frame to A1 A2 pattern. SEF indicates synchronization process is not in the SYNC state as defined by the state diagram of IEEE 802.3ae, clause 50.4.2.	Near-end defect; propagated to PCS	EWIS_RX_ERR _FRC2.FRC_R X_SEF	WIS- STAT3.SEF
LOF	Loss of Frame. Generated when SEF condition persists for 3 ms. Terminated when no SEF occurs for 1 ms to 3 ms.	Near-end defect	EWIS_RX_ERR _FRC2.FRC_R X_LOF	WIS- STAT3.LOF
B1 PMTICK error count is nonzero	BIP-N(S) 32-bit, near-end section BIP error counter is nonzero.	Near-end anomaly	EWIS_RX_ERR _FRC2.FRC_R X_B1	EWIS_INTR_ STAT2.B1_NZ _STAT
B2 PMTICK error count is nonzero	BIP-N(L) 32-bit, near-end line BIP error counter is nonzero.	Near-end anomaly	EWIS_RX_ERR _FRC2.FRC_R X_B2	EWIS_INTR_ STAT2.B2_NZ _STAT
B3 PMTICK error count is nonzero	BIP-N(P) 32-bit, near-end path BIP error counter is nonzero.	Near-end anomaly	EWIS_RX_ERR _FRC2.FRC_R X_B3	EWIS_INTR_ STAT2.B3_NZ _STAT
REI-L	Far-end BIP-N(L) Line Remote Error Indicator octet is nonzero.	Far-end anomaly	EWIS_RX_ERR _FRC2.FRC_R EIL	EWIS_INTR_ STAT2.REIL_ STAT
REI-L PMTICK error count is nonzero	Far-end BIP-N(L) Line Remote Error Indicator is nonzero.	Far-end anomaly	EWIS_RX_ERR _FRC2.FRC_R EIL	EWIS_INTR_ STAT2.REIL_ NZ_STAT
RDI-L	Line Remote Defect Indicator	Far-end defect	EWIS_RX_ERR _FRC1.FRC_R X_RDIL	WIS_STAT3. RDIL
REI-P	Far-end BIP-N(P) Path Remote Error Indicator octet is nonzero.	Far-end anomaly	EWIS_RX_ERR _FRC2.FRC_R X_REIP	EWIS_INTR_ STAT2.REIP_ STAT
REI-P PMTICK error count is nonzero	Far-end BIP-N(P) Path Remote Error Indicator is nonzero.	Far-end anomaly	EWIS_RX_ERR _FRC2.FRC_R EIP	EWIS_INTR_ STAT2.REIP_ NZ_STAT
UNEQ-P	Unequipped Path	Near-end defect	EWIS_RX_ERR _FRC2.FRC_R X_UNEQP	EWIS_INTR_ STAT2.UNEQ P_STAT
Far-end UNEQ-P	Far-end Unequipped Path	Far-end defect	EWIS_RX_ERR _FRC2.FRC_R EIP	EWIS_INTR_ STAT2.FEUN EQP_STAT

### 3.3.19 Overhead Serial Interfaces

The VSC8257-01 device includes provisions for off-chip processing of the critical SONET/ SDH transport overhead 9-bit words through two independent serial interfaces. The transmit overhead serial interface (TOSI) is used to insert 9-bit words into the transmit frames, and the receive overhead serial interface (ROSI) is used to recover the 9-bit words from the received frames. Each interface consists of three pins: a clock output, a frame pulse output, and a data input (Tx) /output (Rx). These I/O are LVTTTL-compatible for easy connection to an external device such as an FPGA.

**Note:** Extended WIS TOSI and ROSI do not support path overhead bytes.

Each ROSI/TOSI interface consumes 6 GPIO pins. This may significantly impact the number of remaining GPIO pins available for other functions. If the ROSI/TOSI interfaces are used for all four channels, 16 GPIO pins are left available for any other functions.

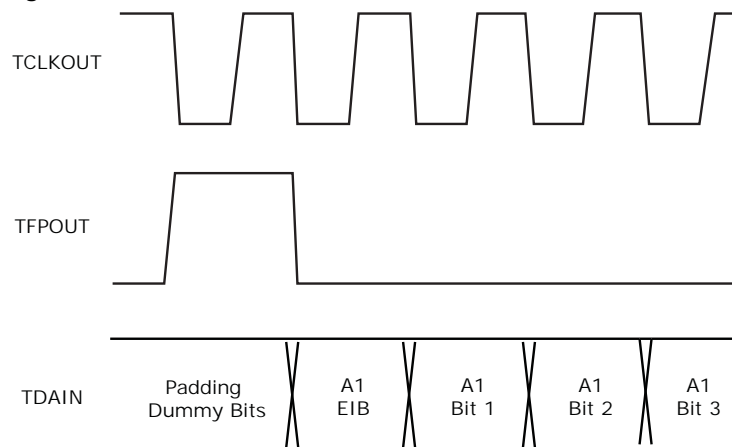
All references to TCLKOUT, TFPOUT, TDAIN, RCLKOUT, RFPOUT and RDAOUT are the TOSI/ROSI signals routed through GPIO package pins.

#### 3.3.19.1 Transmit Overhead Serial Interface (TOSI)

The TOSI port enables the user to individually program 222 separate 9-bit words in the SONET/SDH overhead. The SONET/SDH frame rate is 8 kHz as signaled by the frame pulse (TFPOUT) signal. The TOSI port is clocked from a divided-down version of the WIS transmit clock made available on TCLKOUT. To provide a more standard clock rate, 9-bit dummy words are added per frame resulting in a clock running at one five-hundred-twelfth of the line rate, or 19.44 MHz. For each 9-bit word, the external device indicates the desire to transmit that byte by using an enable indicator bit (EIB) that is appended to the beginning of the 9-bit word. If EIB = 0, the data on the serial interface is ignored for that overhead 9-bit word. If EIB = 1, the serial interface data takes precedence over the value generated within the VSC8257-01 device.

The EIB is present before the 9-bit dummy words too, however its value has no effect as the 9-bit dummy words are ignored within the device. The first EIB bit should be transmitted by the external device on the first rising edge of TCLKOUT after TFPOUT, as illustrated in the following figure. The data should be provided with the most significant bit (MSB) first. After reception of the TOSI data for a complete frame, the values are placed in the overhead for the next transmitted frame.

**Figure 15 • TOSI Timing**



Some 9-bit words are error masks, such that the transmitted 9-bit word is the XOR of the TOSI 9-bit word and the pre-defined value within the chip if the EIB is enabled. This feature is best used for test purposes only.

The order of the 9-bit word required by the TOSI port is summarized in the following table, where the number of registers is the number of bytes on the serial interface, and the number of bytes is the number of STS channels on which the byte is transmitted. For H1 and H2 pointers, bytes 2 to 192 are

concatenation indication bytes consistent with STS-192c frames. There are not 192 different point locations as in STS-192 frames.

**Table 19 • TOSI/ROSI Addresses**

Byte Name	9-Bit Word	TOSI/ROSI Byte Order	Number of Registers	Number of Bytes	Type
Frame boundary	A1	0	1	192	Programmable byte that is identical for all locations
Frame boundary	A2	1	1	192	Programmable byte that is identical for all locations
Section trace	J0	2	1	1	Programmable byte
Section growth	Z0	3	1	191	Programmable byte that is identical for all locations
Dummy byte		4	1	1	Programmable byte
Section BIP-8	B1	5	1	1	TOSI inserts error mask; ROSI extracts XOR of B1 value and received data
Orderwire	E1	6	1	1	Programmable byte
Section user channel	F1	7	1	1	Programmable byte
Dummy byte		8	1	1	Programmable bytes
Section DCC 1	D1	9	1	1	Programmable byte
Section DCC 2	D2	10	1	1	Programmable byte
Section DCC 3	D3	11	1	1	Programmable byte
Dummy byte		12	1	1	Programmable byte
Pointer 1	H1	13	1	1	Programmable byte affecting the first H1 byte
Pointer 2	H2	14	1	1	Programmable byte affecting the first H2 byte
Pointer action	H3	15	1	192	Programmable byte that is identical for all locations
Dummy byte		16	1	1	Programmable byte
Line BIP-8	B2	17 to 208	192	192	TOSI inserts error mask for each byte; ROSI extracts XOR of B2 value and received data for each byte
Automatic protection switching (APS) channel and remote defect indicator (RDI)	K1	209	1	1	Programmable byte
Automatic protection switching (APS) channel and remote defect indicator (RDI)	K2	210	1	1	Programmable byte
Dummy byte		211	1	1	Programmable byte
Line DCC 4	D4	212	1	1	Programmable byte



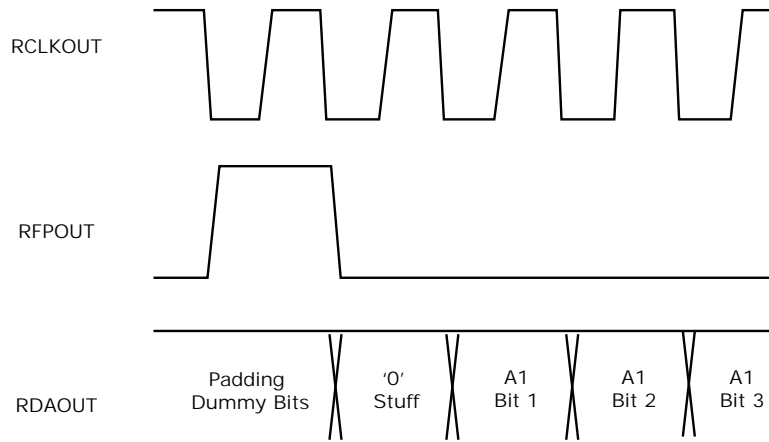
**Table 19 • TOSI/ROSI Addresses (continued)**

Byte Name	9-Bit Word	TOSI/ROSI Byte Order	Number of Registers	Number of Bytes	Type
Line DCC 5	D5	213	1	1	Programmable byte
Line DCC 6	D6	214	1	1	Programmable byte
Dummy byte		215	1	1	Programmable byte
Line DCC 7	D7	216	1	1	Programmable byte
Line DCC 8	D8	217	1	1	Programmable byte
Line DCC 9	D9	218	1	1	Programmable byte
Dummy byte		219	1	1	Programmable byte
Line DCC 10	D10	220	1	1	Programmable byte
Line DCC 11	D11	221	1	1	Programmable byte
Line DCC 12	D12	222	1	1	Programmable byte
Dummy byte		223	1	1	Programmable byte
Synchronization message	S1	224	1	1	Programmable byte
Growth 1	Z1	225	1	191	Programmable byte that is identical for all locations
Growth 2	Z2	226	1	190/191	Programmable byte that is identical for all locations; dependent upon 2xEC40.12
STS-1 REI-L	M0	227	1	1	Programmable byte
STS-N REI-L	M1	228	1	1	Programmable byte
Orderwire 2	E2	229	1	1	Programmable byte
Dummy byte		230	1	1	Programmable byte
Padding dummy bytes		231 to 269	39		No function

### 3.3.19.2 Receive Overhead Serial Interface (ROSI)

The ROSI port extracts the same 222 overhead 9-bit words from the SONET/SDH frame, and consists of the clock output (RCLKOUT), frame pulse output (RFPOUT), and data output (RDAOUT). The ROSI port is clocked from a divided-down version of the WIS receive clock, and is valid during in-frame conditions only. As with the TOSI port, 9-bit dummy words are provided each frame period resulting in a 19.44 MHz RCLKOUT frequency. For each 9-bit word, including the 9-bit dummy words, an extra 0 bit is added at the beginning of each byte so that the TOSI and ROSI clock rates are identical. The first stuff bit for each frame is transmitted by RDAOUT on the first rising edge of RCLKOUT after the frame pulse (RFPOUT), as illustrated in the following figure.

Because the receive path overhead can be split across two frames, the VSC8257-01 device buffers the overhead for an additional frame time so that a complete path overhead is presented. Table 19, page 39 outlines the order for each of the 9-bit words presented on the ROSI port. With the exception of the M0/M1 9-bit words, the extracted 9-bit words are from the first channel position. In place of parity and error 9-bit words, the VSC8257-01 device outputs the result of an XOR between the calculated BIP and the received value. Therefore, a count of ones within each of the BIP 9-bit words should correspond with the internal error accumulators. The following figure shows the functional timing for the ROSI port.

**Figure 16 • ROSI Timing**

### 3.3.20 Pattern Generator and Checker

The VSC8257-01 device implements the square wave, PRBS31, and mixed-frequency test patterns as described in section 50.3.8 of IEEE 802.3ae, as well as the test signal structure (TSS) and continuous identical digits (CID) pattern.

The square wave pattern is selected asserting `WIS_CTRL2.TEST_PAT_SEL`, and the generator is enabled by asserting `WIS_CTRL2.TEST_PAT_GEN`. When `WIS_CTRL2.TEST_PAT_SEL` is deasserted, the mixed frequency test pattern is selected. The square wave frequency is configured according to `EWIS_TXCTRL2.SQ_WV_PW`. The `WIS_CTRL2.TEST_PAT_ANA` bit is used to enable the test pattern checker in the receive path. The checker does not operate on square wave receive traffic. Error counts from the mixed frequency pattern are presented in the SONET/SDH BIP-8 counters, `B1_CNT`, `WIS_B1_CNT`, `WIS_B2_CNT`, and `WIS_B3_CNT`.

The VSC8257-01 device supports the PRBS31 test pattern as reflected in `WIS_STAT2.PRBS31_ABILITY`. The transmitter/generator is enabled by asserting `WIS_CTRL2.TEST_PRBS31_GEN`, while the receiver/checker is enabled by asserting `WIS_CTRL2.TEST_PRBS31_ANA`. Because the mixed frequency/square wave test patterns have priority over the PRBS31 pattern, `WIS_CTRL2.TEST_PAT_GEN` must be disabled for the PRBS31 test pattern to be sent. Error counts from the PRBS31 checker are available in `WIS_TSTPAT_CNT`. This register does not roll over after reaching its maximum count, and is cleared after every read operation.

Two status bits are available from the PRBS checker. The `EWIS_PRBS31_ANA_STAT.PRBS31_ERR` bit indicates whether the error counter is nonzero. The `EWIS_PRBS31_ANA_STAT.PRBS31_ANA_STATE` bit, if asserted, indicates that checker is synchronized and actively checking received bits.

For test purposes, the PRBS generator can inject single bit errors. By asserting `EWIS_PMTICK_CTRL.PMTICK_SRC`, a single bit error is injected, resulting in three bit errors being detected within the checker. The value of three comes from the specification, which indicates one error should be detected for each tap within the checker.

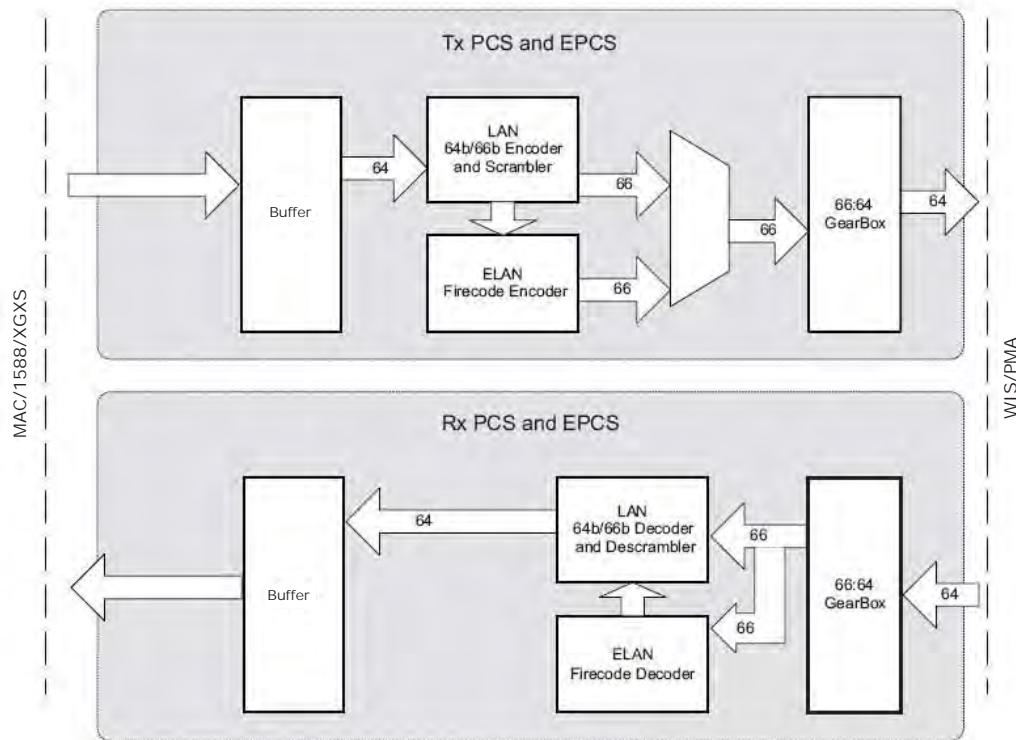
## 3.4 10G Physical Coding Sublayer (64b/66b PCS)

The 10G physical coding sublayer (PCS) is defined in IEEE 802.3ae, Clause 49. It is composed of the PCS transmit, PCS receive, block synchronization, and BER monitor processes. The PCS functions can be further broken down into encode or decode, scramble or descramble, and gearbox functions, as well as various test and loopback modes.

The PCS is responsible for transferring data between the MAC and the WIS/PMA clock domain. In addition, the PCS encodes and scrambles the data for efficient transport across the given medium.

The following illustration provides a block diagram of the 10G PCS block.

Figure 17 • PCS Block Diagram



### 3.4.1 PCS Standard Test Modes

The PCS block offers all of the standard defined test pattern generators and analyzers. In addition, the VSC8257-01 device supports a 64-bit static user pattern and the optional PRBS31 pattern. Two error counters are available. Each is a saturating counter that is cleared upon a read operation. The first, PCS\_ERR\_CNT, is located in the IEEE Standard area while the 32-bit, PCS\_VSERR\_CNT\_0/PCS\_VSERR\_CNT\_1, is located in the vendor specific area.

The IEEE specification defines two test pattern modes, a square wave generator and a pseudo-random test pattern. The square wave generator is enabled by first selecting the square wave pattern by asserting PCS\_TSTPAT\_SEL then enabling the test pattern generator PCS\_TSTPAT\_GEN. The period of the square wave can be controlled in terms of bit times by writing to PCS\_SQPW. There is no associated square wave checker within the VSC8257-01 device. The pseudo-random test pattern is selected by deasserting PCS\_TSTPAT\_SEL. The pseudo-random test pattern contains two data modes. When PCS\_TSTDAT\_SEL is deasserted, the pseudo-random pattern is a revolving series of four blocks with each block 128-bits in length. The four blocks are the resultant bit sequence produced by the PCS scrambler when pre-loaded with the following seeds:

- PCS\_SEEDA\_0, PCS\_SEEDA\_1, PCS\_SEEDA\_2, PCS\_SEEDA\_3
- PCS\_SEEDA invert
- PCS\_SEEDB\_0, PCS\_SEEDB\_1, PCS\_SEEDB\_2, PCS\_SEEDB\_3
- PCS\_SEEDB invert

The pattern generator is enabled by asserting PCS\_TSTPAT\_GEN, while the analyzer is enabled, by asserting PCS\_TSTPAT\_ANA. Errors are accumulated in the clear-on-read saturating counter, PCS\_ERR\_CNT. In pseudo-random pattern mode, the error counter counts the number of errored blocks.

Support for the optional PRBS31 pattern is indicated by PRBS31\_pattern\_testing\_ability register whose default is high. The PRBS31 test generator is selected by asserting PCS\_PRBS31\_GEN, while the checker is enabled by asserting PCS\_PRBS31\_ENA. IEEE standards specify that the error counter

should increment for each linear feedback shift register (LFSR) tap that a bit is in error. Therefore, a single bit error increments the counter by three because there are three taps in the PRBS31 polynomial.

The user-defined 64-bit static pattern can be written to PCS\_USRPAT registers and enabled by asserting PCS\_USRPAT\_ENA and PCS\_TSTPAT\_GEN. Enabling the user-defined pattern enables both the generator and analyzer.

## 3.5 1G Physical Coding Sublayer

The 1G physical coding sublayer implements 1000BASE-X as specified by IEEE 802.3, clause 36, and auto-negotiation as specified by IEEE 802.3, clause 37. It provides for the encoding (and decoding) of GMII data octets to (from) ten-bit code-groups (8B/10B) for communication with the underlying PMA. It also manages link control and the auto-negotiation process.

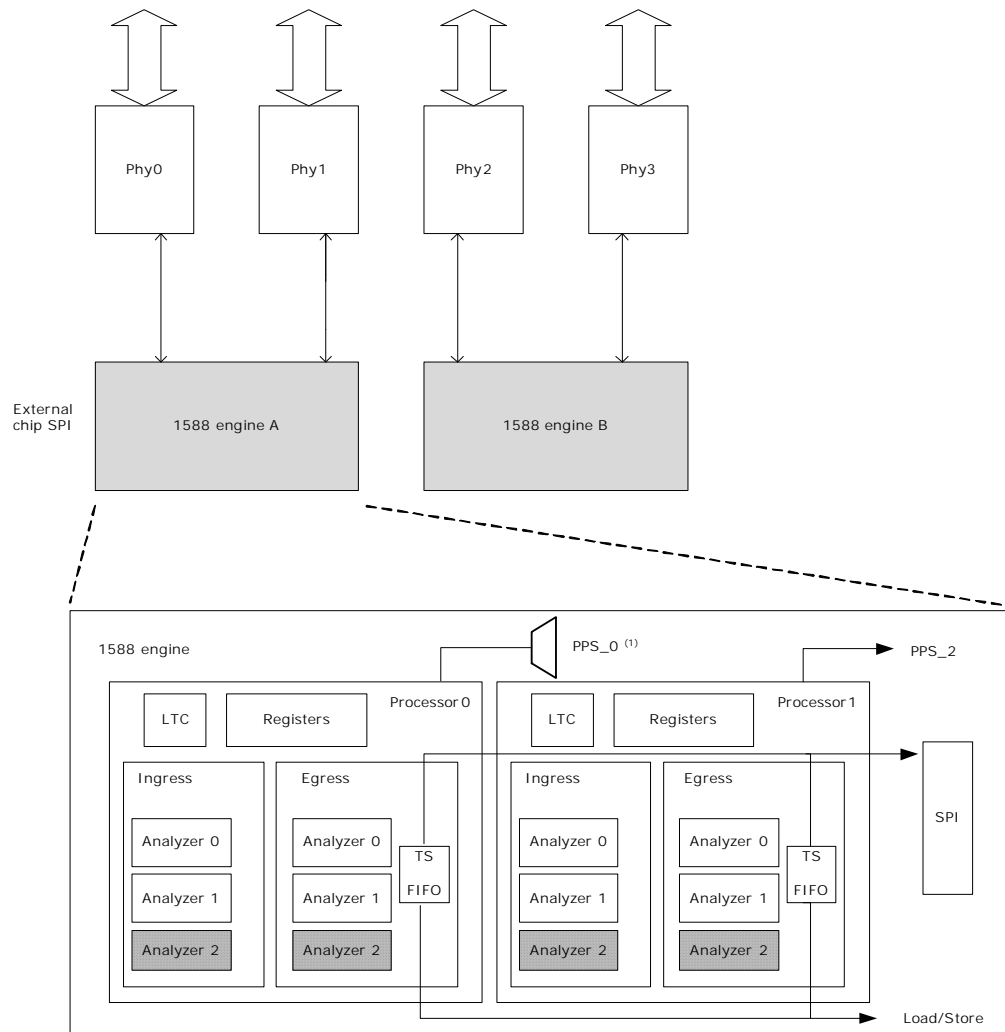
In addition to these standard 1000BASE-X functions, the 1G PCS also includes a conversion function that maps the standard GMII data to (from) an internal XGMII-like interface. This allows the processing core to be largely agnostic to whether a channel is operating in 1G or 10G operation.

## 3.6 IEEE 1588 Block Operation

The VSC8257-01 device uses a second generation IEEE 1588 engine that is backward compatible with the earlier version of VeriTime™, the Microsemi IEEE 1588 time stamping engine. It is also compatible with the IEEE 1588 operations supported in Microsemi CE switches. The following list shows the new features of the Microsemi second generation IEEE 1588.

- Enhanced time stamp accuracy and resolution
- Automatic clear enables after system time is read or written
- Ability to load or extract the current system time in serial format
- Full 48-bit math support for incoming correction field
- Ability to add or subtract fixed offset from system time to synchronize between slaves
- Independent control and bypass for each direction of IEEE 1588
- Support to extract frame signature in an IPv6 frame
- MPLS-TP OAM support in third analyzer engine
- Special mode where all frames traversing the system can be time stamped

The unique architecture of the second generation IEEE 1588 block provides for the lowest latency and maximum throughput on the channel. The following illustration shows a block diagram of the IEEE 1588 architecture in the VSC8257-01 device.

**Figure 18 • IEEE 1588 Architecture**

(1) PPS\_0 MUX control used to access PHY 0 through PHY3

The following sections list some of the major IEEE 1588 applications.

### 3.6.1 IEEE 1588 Block

The IEEE 1588 engine may be configured to support one-step and two-step clocks as well as Ethernet and MPLS OAM delay measurement. It detects the IEEE 1588 frames in both the Rx and Tx paths, creates a time stamp, processes the frame, and updates them. It can add a 30/32-bit Rx time stamp to the 4-bytes reserved field of the PTP packet. It can also modify the IEEE 1588 correction field and update the CRC of changed frames. There are local time counters (reference for all time stamps) that can be preloaded and adjusted through the register interface.

A local time counter is used to hold the local time for Rx and Tx paths. A small FIFO delays frames to allow time for processing and modification. An analyzer detects the time stamp frames (PTP and OAM) and a time stamp block calculates the new correction field. The rewriter block replaces the correction field with an updated one and checks/calculates the CRC. For the Tx path, a time stamp FIFO saves Tx event time stamp plus frame identifier for use in some modes.

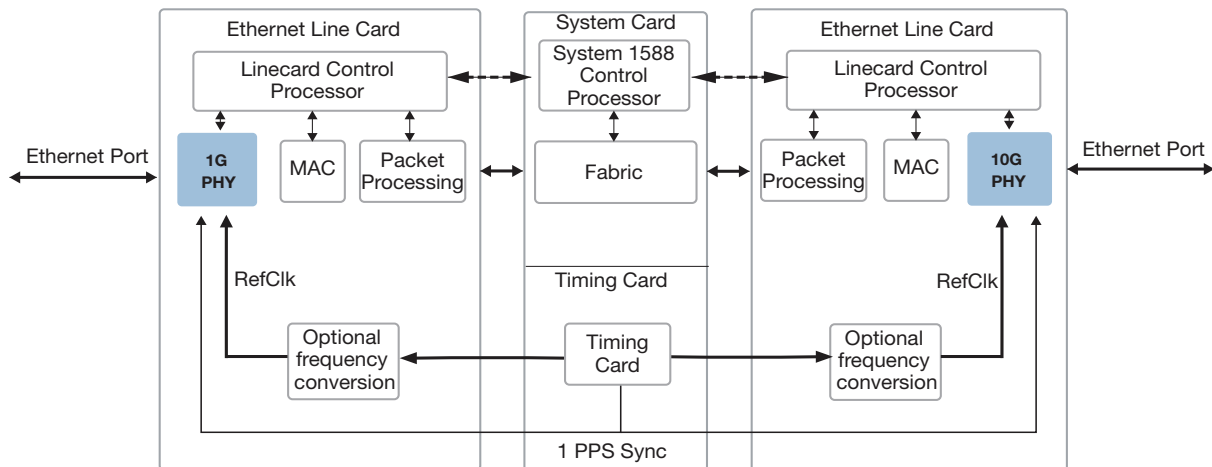
The IEEE 1588 engine's registers and time stamps are accessible through the MDIO or 4-pin SPI. To overcome the MDIO or 4-pin SPI speed limitations, the dedicated "push-out" style SPI output bus can be used for faster or large amounts of time stamp reads. This SPI output is used to push out time stamp information to an external device only and does not provide read/write to the registers of the IEEE 1588 engine or registers of other blocks in the VSC8257-01 device. In addition, there is a LOAD/SAVE pin that

is used to load the time in the PHYs and ensure that all the PHYs are in sync. The local time counter may come from any one of the following sources:

- Data path clock (varies according to mode)
- 250 MHz from host-side PLL
- External clock (125 MHz or 250 MHz) from CLK1588P/N pins

The local time counters contain two counters: nanosecond\_counter and second\_counter. The 1 PPS (pulse per second signal) output pin can be used for skew monitoring and adjustment. The following illustration shows an overview of a typical system using IEEE 1588 PHYs. The LOAD/SAVE and 1 PPS pins are signals routed to the GPIO pins. The following illustration shows how the PHY is embedded in a system.

**Figure 19 • IEEE 1588 Block Diagram**



The system card has to drive the refclk (125 MHz or 250 MHz timetick clock) to all the PHYs, including the VSC8257-01 device. The system clock may need local frequency conversion to match the required reference clock frequency. The system clock may be locked to a PRC by SyncE or by IEEE 1588. If locked by IEEE 1588, the central CPU recovers the PTP timing and adjusts the frequency of the system clock to match the PTP frequency. If the system clock is free running, the central CPU must calculate the frequency offset between the system clock and the synchronized IEEE 1588 clock and program the PHYs to make internal adjustments.

The system card also provides a sync pulse to all PHYs, including the VSC8257-01 device to the LOAD/SAVE pin. This signal is used to load the time to the PHYs and to ensure that all the PHYs are in sync. This may just be a centrally divided down system clock that gives a pulse at fixed time intervals. The delay from the source of the signal to each PHY must be known and taken into account when writing in the load time in the PHYs.

The VSC8257-01 device supports a vast variety of IEEE 1588 applications. In simple one-step end-to-end transparent clock applications, the VSC8257-01 device can be used without any central CPU involvement except for initial configuration. The IEEE 1588 block inside the VSC8257-01 device forwards Sync and Delay\_req frames with automatic updates to the Correction field.

In other applications, the VSC8257-01 device enhances the performance by working with a central processor that runs the IEEE 1588 protocol. The VSC8257-01 device performs the accurate time stamp operations needed for all the different PTP operation modes. For example, at startup in a boundary clock application, the central CPU receives PTP sync frames that are time stamped by the ingress PHY and recovers the local time offset from the PTP master using the PTP protocol. It then sets the save bit in the VSC8257-01 device connected to the PTP master and later reads the saved time. The central CPU loads the expected time (time of the next LOAD/SAVE pulse, corrected by the offset to the recovered PTP time) into the PHY and sets the save bit. It checks that the time offset is 0. If not, it makes small adjustments to the time in the PHY by issuing add 1 ns or subtract 1 ns commands to the VSC8257-01 device through MDIO, until the time matches the PTP master. A save command is issued to the PHY connected to the PTP master and reads the saved time. The central CPU then writes the saved time plus the sync pulse interval plus any sync pulse latency variation (trace length difference compared to the

PHY connected to the PTP master) to the other PHYs and sets the load bit in these VSC8257-01 devices.

The preceding sequence may be completed in several steps. Not all PHYs need to be loaded at once. The central CPU sets the save bit in all PHYs and reads back the values. They should all save the same value.

The central CPU continuously detects if the system time drifts off compared to the recovered PTP time. If needed, it can adjust each PHY for any known skew between PHYs without affecting the operation of the device. It can program the PHYs, including the VSC8257-01 device, to automatically add 1 ns or subtract 1 ns at specific time intervals.

### 3.6.2 IEEE 1588v2 One-Step End-to-End Transparent Clock

Unique advantages for implementing IEEE 1588-2008 are as follows:

- When several VSC8257-01 devices or Microsemi PHYs with integrated IEEE 1588 time stamping blocks are used on all ports within the system that support IEEE 1588 one-step E2E TC, the rest of the system does not need to be IEEE 1588 aware, and there is no CPU maintenance needed once the system is set up
- As all the PHYs in a system can be configured the same way, it supports fail-over of IEEE 1588 masters without any CPU intervention
- VSC8257-01 and other Microsemi PHYs with integrated IEEE 1588 time stamping blocks also work for pizza box solutions, where the switch/router can be upgraded to support IEEE 1588 E2E TC

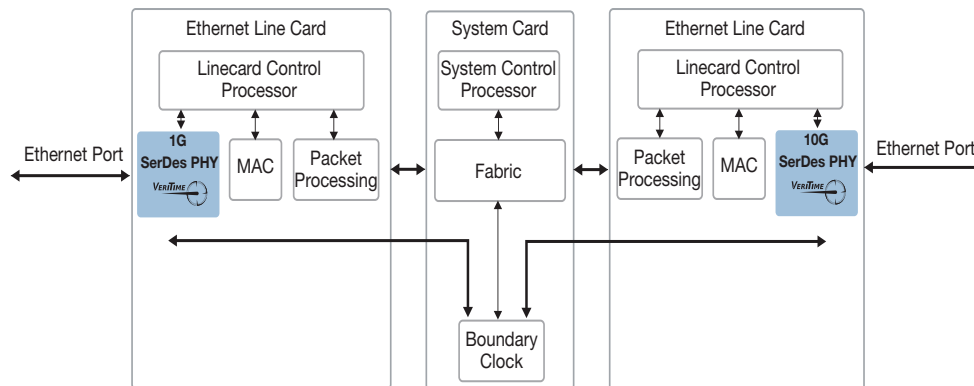
Requirements for the rest of the system are as follows:

- Delivery of a synchronous global timetick clock (or reference clock) to ensure that the “local time” for all PHYs in the system progresses at the same rate.
- Delivery of a global timetick load to synchronize the local time counters in each PHY.
- CPU access to each PHY to set up the required configuration. This can be through MDIO, two-wire slave, or 4-pin SPI.

### 3.6.3 IEEE 1588v2 Transparent Clock and Boundary Clock

This is the same system as described previously, with the addition of a central IEEE 1588 engine (Boundary Clock). The IEEE 1588 engine is most likely a CPU system, possibly together with hardware support functions to generate Sync frames (for BC and ordinary clock masters). The switch/fabric needs to have the ability to redirect (and copy) PTP frames to the IEEE 1588 engine for processing.

**Figure 20 • IEEE 1588 Transparent Clock and Boundary Clock Line Card Application**



This solution also works for pizza boxes. To ensure that blade redundancy works, the PHYs for the redundant blades must have the same 1588-in-the-PHY configuration. Requirements for the rest of the system are:

- Delivery of a synchronous global timetick clock (or reference clock) to the PHYs
- Delivery of a global timetick load, that synchronizes the local time counters in each port
- CPU access to each PHY to set up the required configuration. For one-step support, this can be MDC/MDIO. For two-step support, a higher speed CPU interface (such as the SPI) might be

required (depending on the number of time stamps that are required to be read by the CPU). In blade systems it might be required to have a local CPU on the blade that collects the information and sends it to the central IEEE 1588 engine by means of the control plane or the data plane. In advanced MAC/Switch devices this might be an internal CPU

- Fabric must be able to detect IEEE 1588 frames and redirect them to the central IEEE 1588 engine

The same solution can also be used to add Y.1731 delay measurement support. This does not require a local CPU on the blade, but the fabric must be able to redirect OAM frames to a local/central OAM processor

### 3.6.4 Enhancing IEEE 1588 Accuracy for CE Switches and MACs

Connecting VSC8257-01 or other Microsemi PHYs that have integrated IEEE 1588 time-stamping in front of the CE Switches and MACs improves the accuracy of the IEEE 1588 time stamp calculation. This is due to the clock boundary for the SGMII/QSGMII interface. It will also add support for one-step TC and BC on Microsemi's Jaguar family of devices.

### 3.6.5 Supporting One-Step Boundary Clock/Ordinary Clock

In one-step boundary clock, the boundary clock device acts as an ordinary clock slave on one port and as master on the other ports. On the master ports, sync frames are transmitted from the IEEE 1588 engine that holds the Origin time stamp. These frames will have the correction field or the full Tx time stamp updated on the way out through the PHY.

Master ports also receive Delay\_req from the slaves and respond with Delay\_resp messages. The Delay\_req messages are time stamped on ingress through the PHY and the IEEE 1588 engine receives the Delay\_req frame and generates a Delay\_resp message. The Delay\_resp messages are not event messages and are passed through the PHY as any other frame.

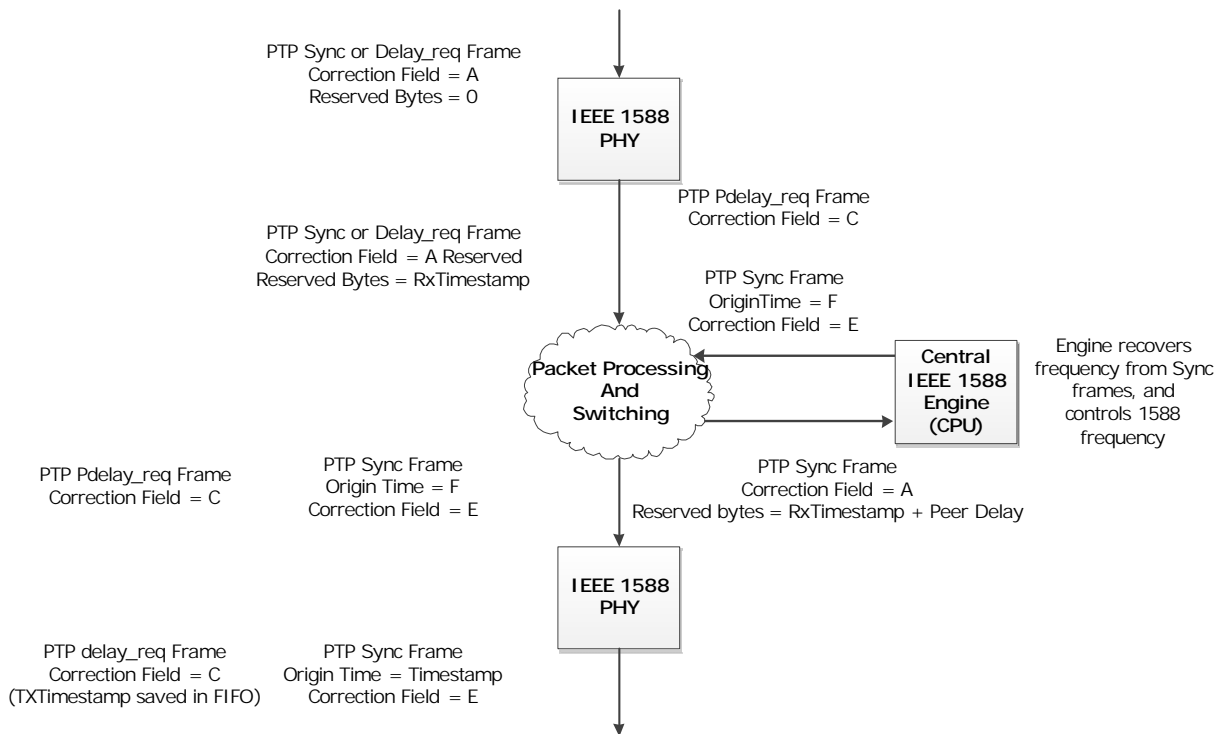
The port configured as slave receives Sync frames from its master. The Sync frames have an Rx time stamp added in the PHY and forwarded to the IEEE 1588 engine.

The IEEE 1588 engine also generates Delay\_req frames that are sent on the port configured as slave port. Normally the transmit time for the Delay\_req frames,  $t_3$ , is saved in a time stamp FIFO in the PHYs, but when using Microsemi IEEE 1588 PHYs a slight modification can be made to the algorithm to remove the CPU processing overhead of reading the  $t_3$  time stamp.

To modify the algorithm, the IEEE 1588 engine should send the Delay\_req message with a software generated  $t_3$  value in the origin time stamp, the sub-second value of the  $t_3$  time stamp in the reserved bytes of the PTP header and a correction field of 0. The software generated  $t_3$  time stamp should be within a second before the actual  $t_3$  time. The Egress PHY should then be configured to perform E2E TC egress operation, meaning calculate the "residence time" from the inserted  $t_3$  time stamp to the actual  $t_3$  time and insert this value in the correction field of the frame. When the local IEEE 1588 engine receives the corresponding Delay\_resp frame back it can use the software generated  $t_3$  value because the correction field of the Delay\_resp frame contains a value that compensates for the actual  $t_3$  transmission time.

Boundary clocks and ordinary clocks must also reply to Pdelay\_req messages just as P2P TC using the same procedure for the P2P TC. For more information, see [Supporting One-Step Peer-to-Peer Transparent Clock](#), page 54.



**Figure 21 • One-Step End-to-End Boundary Clock**

### 3.6.5.1 Ingress

Each time the PCS/PMA detects the start of a frame, it sends a pulse to the time stamp block, which saves the value of the Local\_Time received from the Local Time counter. In the time stamp block, the programmed value in the local\_correction register is subtracted from the saved time stamp. The local\_correction register is programmed with the fixed latency from the measurement point to the place that the start of frame is detected in the PCS/PMA logic. The time stamp block also contains a register that can be programmed with the known link asymmetry. This value is added or subtracted from the correction field, depending on the frame type.

When the frame leaves the PCS/PMA block, it is loaded into a small FIFO block that delays and stores the frame data for a few clock cycles to allow for later modifications of the frame. The data is also copied to the analyzer block that parses the incoming frame to detect whether it is an IEEE 1588 Sync or Delay\_req frame belonging to the PTP domain that the system is operating on. If so, it signals to the ingress time stamp block in the PHY which action to perform (Write). It also delivers the write offset and data size (location of the four reserved bytes in the PTP header, 4 bytes wide) to the rewriter block in the PHY.

If the analyzer detects that the frame is not matched, it signals to the time stamp block and the rewriter block to ignore the frame (NOP), which allows it to pass unmodified and flushes the saved time stamp in the time stamp block.

If the time stamp block gets the Write action, it delivers the value of the calculated time stamp for the frame to the rewriter block and the rewriter block adds this time stamp (ns part of it) to the four reserved bytes in the frame and recalculates FCS.

The rewriter block takes data out of the FIFO block continuously and feeds it to the system side PCS/PMA block using a counter to keep track of the byte positions of the frame. When the rewriter block receives a signal from the time stamp block to rewrite a specific position in the frame (that information comes from the analyzer block), it overwrites the position with the data from the time stamp block and replaces the FCS of the frame. The rewriter also checks the original FCS of the frame to ensure that a frame that is received with a bad FCS and then modified by the rewriter is also sent out with a bad FCS. This is achieved by inverting the new FCS. If the frame is an IPv4 frame the rewriter ensures that the IP checksum is 0. If the frame is IPv6 the rewriter keeps track of the modifications done to the frame and

modifies a couple of bytes placed at the end of the PTP frame (for this specific purpose) so that the IP checksum stays correct.

The following full calculations are performed:

- Sync frames: Reserved\_bytes = (Raw\_Timestamp\_ns – Local\_correction) Correction field = Original Correction field + Asymmetry
- Delay\_req frames: Reserved\_bytes = (Raw\_Timestamp\_ns – Local\_correction)

### 3.6.5.2 Egress

When a frame is received from the system side PCS/PMA block it is loaded into a FIFO block that delays and stores the frame data for a few clock cycles to allow for later modifications of the frame. The data is also copied to the analyzer block that parses the incoming frame to detect whether it is an IEEE 1588 Sync or Delay\_req frame belonging to the PTP domain that the system is operating on.

If the egress analyzer of the PHY detects that the frame is an IEEE 1588 Sync frame belonging to the PTP domain(s) of the system, it signals to the egress time stamp block which action to perform (Write). It also delivers the write offset and data size (location of the Tx time stamp inside the frame, 10 bytes wide) to the rewriter.

If the egress analyzer detects that the frame is an IEEE 1588 Delay\_req frame belonging to the PTP domain(s) of the system, it signals to the time stamp block which action to perform (Write, Save). It also delivers the write offset and data size (location of the Tx time stamp inside the frame, 10 bytes wide) to the rewriter. It also outputs up to 16 bytes of frame identifier to the Tx time stamp FIFO, to be saved along with the Tx time stamp. The frame identifier bytes are selected information from the frame, configured in the analyzer.

If the time stamp block gets the (Write, Save) action it delivers the calculated time stamp and signals to the time stamp FIFO block that it must save the time stamp along with the frame identifier data it received from the analyzer block.

The Tx time stamp FIFO block contains a buffer memory. It simply stores the Tx time stamp values that it receives from the time stamp block together with the frame identifier data it receives from the analyzer block and has a CPU interface that allows the IEEE 1588 engine to read out the time stamp sets (Frame identifier + New Tx time stamp).

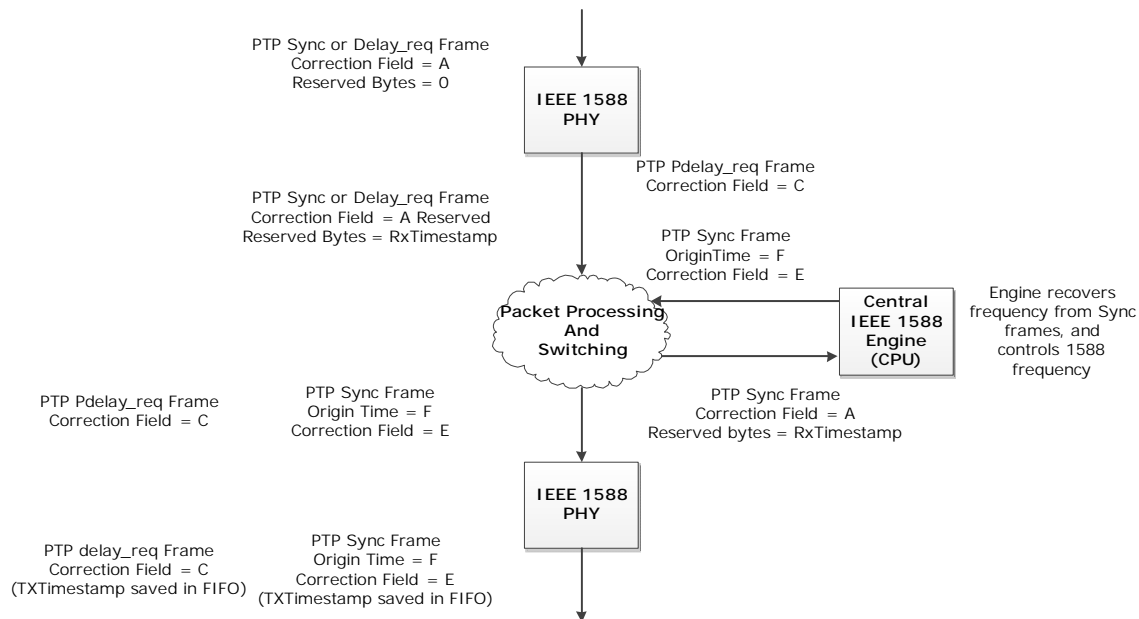
The following full calculations are performed:

- Sync frames: OriginTimestamp = (Raw\_Timestamp + Local\_correction)
- Delay\_req frames: OriginTimestamp = (Raw\_Timestamp + Local\_correction) Correction field = Original Correction field + Asymmetry

### 3.6.6 Supporting Two-Step Boundary Clock/Ordinary Clock

Two-step clocks are used in systems that cannot update the correction field on-the-fly and this requires more CPU processing than one-step.

Each time a Tx time stamp is sent in a frame, the IEEE 1588 engine reads the actual Tx transmission time from the time stamp FIFO and issues a follow-up message containing this time stamp. Even though the VSC8257-01 device supports one-step operation, thereby eliminating the need to run in two-step mode, support for this mode is provided for networks that include two-step-only implementations.

**Figure 22 • Two-Step End-to-End Boundary Clock**


### 3.6.6.1 Ingress

If the ingress analyzer in the PHY detects that the frame is an IEEE 1588 Sync or Delay\_req frame belonging to the PTP domain(s) of the system, it signals to the time stamp block which action to perform (Write). It also delivers the write offset and data size (location of the four reserved bytes in the PTP header, 4 bytes wide) to the rewriter.

If the time stamp block gets the Write action, it delivers the calculated time stamp to the rewriter block and the rewriter block adds this time stamp (ns part of it) to the four reserved bytes in the frame and recalculates FCS.

**Note:** When secure timing delivery is required, when using IPsec authentication for instance, the four reserved bytes must be reverted back to 0 before performing integrity check.

The following full calculations are performed:

- Sync frames: Reserved\_bytes = (Raw\_Timestamp – Local\_correction)  
Correction field = Original Correction field + Asymmetry
- Delay\_req frames: Reserved\_bytes = (Raw\_Timestamp – Local\_correction)

### 3.6.6.2 Egress

If the egress analyzer detects that the frame is an IEEE 1588 Sync or Delay\_req frame belonging to the PTP domain(s) of the system, it signals to the time stamp block which action to perform (Write, Save). The analyzer outputs up to 15 bytes of frame identifier to the Tx time stamp FIFO to be saved along with the Tx time stamp. The frame identifier must include, at a minimum, the sequenceId field so the CPU can match the time stamp with the follow-up frame.

If the time stamp block gets the Write, Save action it delivers the calculated time stamp to the time stamp FIFO and signals to the time stamp FIFO block that it must save the time stamp along with the frame identified data it received from the analyzer block.

The following full calculations are performed:

- Sync frames: FIFO = (Raw\_Timestamp + Local\_correction)
- Delay\_req frames: FIFO = (Raw\_Timestamp + Local\_correction)  
Correction field = Original Correction field – Asymmetry

### 3.6.7 Supporting One-Step End-to-End Transparent Clock

End-to-end transparent clocks add the residence time (the time it takes to traverse the system from the input to the output port(s)) to all Sync and Delay\_req frames. It does not need to have any knowledge of the actual time, but if it is not locked to the frequency of the IEEE 1588 time, it will produce an error that is the ppm difference in frequency times the residence time.

When the TC is frequency-locked by means of IEEE 1588 or other methods (SyncE), the error is only caused by sampling inaccuracies.

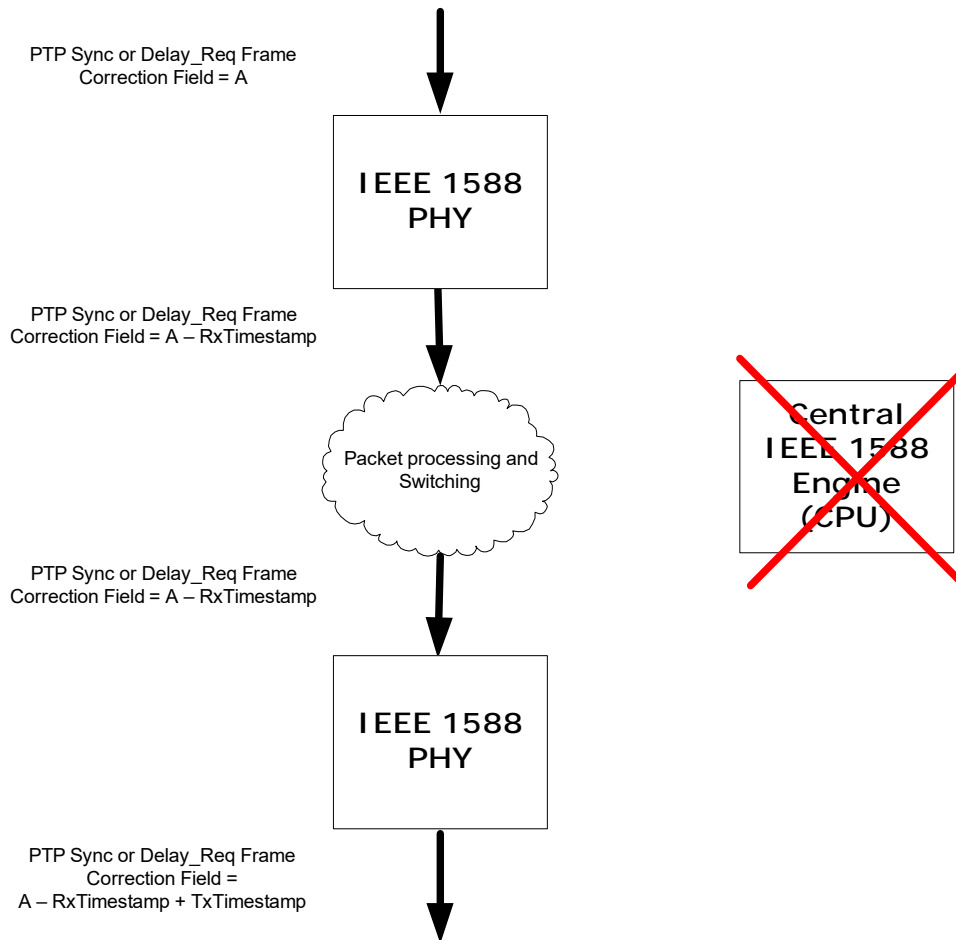
The VSC8257-01 device supports a number of different transparent clock modes that can be divided into two main modes, as follows.

- **Mode A.** Subtracts the ingress time stamp at ingress and adds the egress time stamp at egress. This mode can run in a number of sub-modes, depending on the format of the time stamp that is subtracted or added.
- **Mode B.** Saves the ingress time stamp in the reserved bytes of the PTP header (just as is done in BC and ordinary clock modes) and performs the residence time calculation at the egress PHY where the calculated residence time is added to the correction field of the PTP frame.

Mode B is recommended because it has a number of advantages, including the option to support TC and BC operation in the same system and on the same traffic and the ease of implementing syntonized TC operation.

When an E2E TC recovers frequency using IEEE 1588 and is using Mode A, it must either have a PHY with IEEE 1588 time stamping Mode A support or another way of adding the local time to the correction field placed in front of the IEEE 1588 engine. The IEEE 1588 engine is then able to receive sync frames and adjust the local frequency to match the IEEE 1588 time.

If using Mode B the IEEE 1588 engine can recover the frequency directly from the Sync frames because it can extract the ingress time stamp directly from the frames. The frequency adjustment can be done by adjusting the time counter in each PHY or by adjusting the global Timetick clock.

**Figure 23 • One-Step End-to-End Transparent Clock Mode A**


When the system works in one-step E2E TC mode Sync and Delay\_req frames must be forwarded through the system and the residence time = (Egress time stamp – Ingress time stamp) must be added to the correction field in the frame before it leaves the system.

The following sections describe the operation in Modes A and B.

### 3.6.7.1 Ingress (Mode A)

If the analyzer detects that the frame is an IEEE 1588 Sync or Delay\_req frame belonging to the PTP domain(s) of the system, it signals to the time stamp block which action to perform (Subtract), along with the correction field of the frame. It also delivers the write offset and data size (location of the correction field inside the frame, 8 bytes wide) to the rewriter.

If the time stamp block gets the Subtract action, it subtracts the time stamp converted to ns from the original correction field of the frame and outputs the value to the rewriter block.

As a result the frame is sent towards the system with a correction field containing the value: Original Correction field – Rx time stamp (converted to ns).

The following full calculations are performed:

- Sync frames: Internal Correction field = Original Correction field – (Raw\_Timestamp\_ns – Local\_correction) + Asymmetry
- Delay\_req frames: Internal Correction field = Original Correction field – (Raw\_Timestamp\_ns – Local\_correction)

### 3.6.7.2 Egress (Mode A)

The egress side works that same way as ingress, but the analyzer is set up to add the active\_timestamp to the correction field.

If the analyzer detects that the frame is an IEEE 1588 Sync or Delay\_req frame belonging to the PTP domain(s) of the system, it signals to the time stamp block which action to perform (Add), along with the correction field of the frame. It also delivers the write offset and data size (location of the correction field inside the frame, 8 bytes wide) to the rewriter.

If the analyzer detects that the frame is not matched, it signals the time stamp block and the rewriter block to ignore the frame (let it pass unmodified and flush the saved time stamp in the time stamp block).

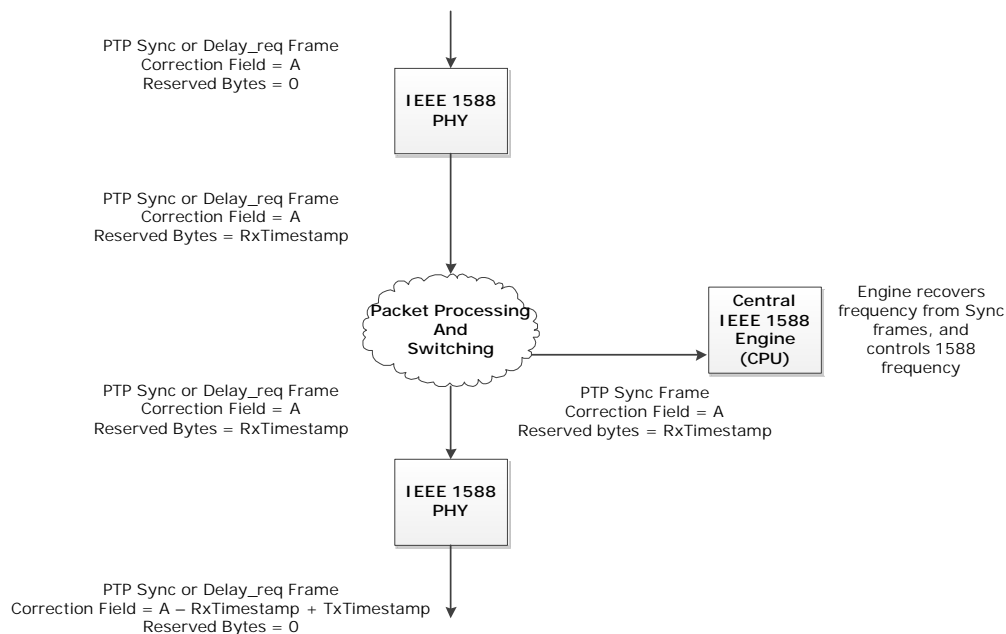
If the time stamp block gets the Add action, it adds the current value of the active\_timestamp to the value of the correction field received from the analyzer and outputs the value to the rewriter block.

When the rewriter block receives a signal from the analyzer block to rewrite a specific position in the frame, it overwrites the position with the data received from the time stamp block and replaces the FCS of the frame. The rewriter also checks the original FCS of the frame and ensures that a frame that is received with a bad FCS and then modified by the rewriter is also sent out with a bad FCS. This is achieved by inverting the new FCS.

The following full calculations are performed:

- Sync frames: Correction field = Internal Correction field + (Raw\_Timestamp\_ns + Local\_correction)
- Delay\_req frames: Correction field = Internal Correction field + (Raw\_Timestamp\_ns + Local\_correction) – Asymmetry

**Figure 24 • One-Step End-to-End Transparent Clock Mode B**



### 3.6.7.3 Ingress (Mode B)

In ingress mode B, all calculations are performed at the egress port.

On the ingress side, when the analyzer detects Sync or Delay\_req frames it adds the Rx time stamp to the four reserved bytes in the PTP frame.

The following full calculations are performed:

- Sync frames: Reserved\_bytes = Raw\_Timestamp\_ns – Local\_correction Correction field = Original Correction field + Asymmetry
- Delay\_req frames: Reserved\_bytes = Raw\_Timestamp\_ns – Local\_correction

### 3.6.7.4 Egress (Mode B)

All calculations are done at the egress side. When the analyzer detects Sync or Delay\_req frames it performs the following calculation:

$$\text{Correction field} = \text{Original Correction field} + \text{Tx time stamp} - \text{Rx time stamp}$$

The value of the Rx time stamp is extracted from four reserved bytes in the PTP header. The four reserved bytes are cleared back to 0 before transmission.

The result is that every Sync and Delay\_req frame that belongs to the PTP domain(s) and is configured as one-step E2E TC in the system will exit the system with a correction field that contains the following:

$$\text{Correction field} = \text{Original correction field} + \text{Tx time stamp} - \text{Rx time stamp}$$

All this is done without any interaction with a CPU system, other than the initial setup. There is no bandwidth expansion. Standard switching/routing tunneling can be done between the ingress and egress PHY, provided that the analyzers in the ingress PHY and egress PHY are set up to catch the Sync and Delay\_req on both. If the PTP Sync and Delay\_req frames are modified inside the system, the egress analyzer must be able to detect the egress Sync and Delay\_req frames; otherwise, the egress Sync and Delay\_req frames will have an incorrect correction field.

The following full calculations are performed:

- Sync frames: Correction field = Original Correction field + (Raw\_Timestamp\_ns + Local\_correction) – Reserved\_bytes
- Delay\_req frames: Correction field = Original Correction field + (Raw\_Timestamp\_ns + Local\_correction) – Reserved\_bytes – Asymmetry

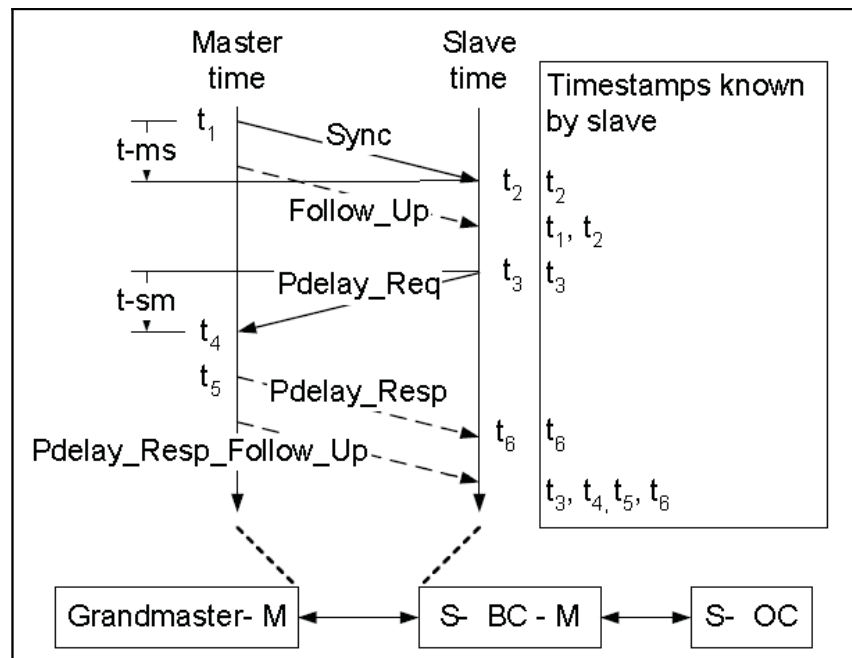
## 3.6.8 Supporting One-Step Peer-to-Peer Transparent Clock

When a Sync frame traverses a P2P TC, the correction field is updated with both the residence time and the calculated path delay on the port that the Sync frame came in on.

### 3.6.8.1 Peer Link Delay Measurement

In P2P TC, the P2P TC device actively sends and receives Pdelay\_req and Pdelay\_resp messages, and calculates the path delays to each neighbor node in the PTP network. The following illustration shows the delay measurements.

Figure 25 • Delay Measurements



To calculate the path delays on a link, the IEEE 1588 engine (located somewhere in the system) generates Pdelay\_Req messages on all ports. When transmitted, the actual Tx time stamp t3 is saved for the CPU to read.

When a P2P TC, BC, or OC receives a Pdelay\_Req frame, it saves the Rx time stamp (t4) and generates a Pdelay\_Resp frame, which adds t5 – t4 to the correction field copied from the received Pdelay\_Req frame, where t5 is the time that the Pdelay\_Resp leaves the port (t5).

When a P2P TC receives the Pdelay\_Resp frame, it saves the Rx time stamp (t6) and then calculates the path delay as (t6 – t3 – the correction field of the frame)/2. The time stamp corrections are combined into a single formula as follows:

$$\text{Path delay} = (t6 - (t3 + (t5 - t4)))/2 = (t6 - t3 - t5 + t4)/2 = ((t4 - t3) + (t6 - t5))/2$$

The two path delays are divided by two, but in such a way as to cancel out any timing difference between the two devices.

A slight modification can be made to the algorithm to remove the CPU processing overhead of reading the t3 time stamp. To modify the algorithm, the IEEE 1588 engine should send the Pdelay\_req message with a software generated t3 value in the origin time stamp, the sub-second value of the t3 time stamp in the reserved bytes of the PTP header, and a correction field of 0. The software generated t3 time stamp should just be within a second before the actual t3 time. The egress PHY should then be configured to perform E2E TC egress operation, meaning calculate the “residence time” from the inserted t3 time stamp to the actual t3 time and insert this value in the correction field of the frame. When the IEEE 1588 engine receives the corresponding Pdelay\_resp frame back it can use the software generated t3 value as the correction field of the Pdelay\_resp frame will contain a value that compensates for the actual t3 transmission time.

A P2P TC adds the calculated one-way path delay to the ingress correction field, and this ensures that the time stamp + correction field in the egress Sync frames is accurate and a slave connected to the P2P TC only needs to add the link delay from the TC to the slave.

The following sections describe both the standard and modified methods for taking P2P measurements. As with E2E TC operations, the VSC8257-01 device also supports the different TC modes: mode A (with different time stamp formats) and mode B. Mode B is also the preferred method to implement P2P TC.

### 3.6.8.2 Ingress, Mode A

If the analyzer detects that the frame is an IEEE 1588 Sync frame belonging to the PTP domain(s) of the system, it signals to the time stamp block which action to perform (subtract\_p2p), along with the correction field of the frame. It also delivers the write offset and data size (location of the correction field inside the frame, 8 bytes wide) to the rewriter.

If the analyzer detects that the frame is an IEEE 1588 Pdelay\_req or Pdelay\_resp frame belonging to the PTP domain(s) of the system, it signals to the time stamp block which action to perform (Write). It also delivers the write offset and data size (location of the reserved 4 bytes in the PTP header that is used to save the ns part of the Rx time stamp, 4 bytes wide) to the rewriter.

If the time stamp block gets the subtract\_p2p action, it subtracts the value in the ingress time stamp from the correction\_field data, adds the configured path delay value, and delivers the result to the rewriter block.

If the time stamp block gets the Write action, it outputs the value of the ingress time stamp register to the rewrite block and the rewriter block writes the sub-second value to the reserved bytes in the PTP header.

The following full calculations are performed:

- Sync frames: Internal Correction field = Original Correction field – (Raw\_Timestamp\_ns – Local\_correction) + Path\_delay + Asymmetry
- Pdelay\_req frames: Reserved\_bytes = Raw\_Timestamp\_ns – Local\_correction
- Pdelay\_resp frames: Reserved\_bytes = Raw\_Timestamp\_ns – Local\_correction  
Correction Field = Original Correction field + Asymmetry



### 3.6.8.3 Egress, Mode A

If the analyzer detects that the frame is an IEEE 1588 Sync frame belonging to the PTP domain(s) of the system, it signals to the time stamp block which action to perform (Add), along with the correction field of the frame. It also delivers the write offset and data size (location of the correction field inside the frame, 8 bytes wide) to the rewriter.

If the analyzer detects that the frame is an IEEE 1588 Pdelay\_req frame belonging to the PTP domain(s) of the system, it signals to the time stamp block which action to perform (Sub\_add), along with the original correction field of the frame (will have the value of 0) and the time stamp extracted from the reserved bytes. It also delivers the write offset and data size (location of the correction field inside the frame, 8 bytes wide) to the rewriter.

If the user prefers to use the normal t3 handling where the t3 time stamp is saved in a time stamp FIFO, the following configuration should be used: If the analyzer detects that the frame is an IEEE 1588 Pdelay\_req frame belonging to the PTP domain(s) of the system, it signals to the time stamp block which action to perform (Write, Save), along with the original correction field of the frame (will have the value of 0). It also delivers the write offset and data size (0 No data is actually written into the frame) to the rewriter. In addition it outputs the field that holds the frame identifier (sequenceId from the PTP header) to the time stamp FIFO, to save along with the Tx time stamp.

If the analyzer detects that the frame is an IEEE 1588 Pdelay\_resp frame belonging to the PTP domain(s) of the system, it signals to the time stamp block which action to perform (Sub\_add), along with the original correction field of the frame (will have the value of the CF received from the Pdelay\_req frame) and the time stamp extracted from the reserved bytes. It also delivers the write offset and data size (location of the correction field inside the frame, 8 bytes wide) to the rewriter.

If the analyzer detects that the frame is not matched, it signals to the time stamp block and the rewriter block to ignore the frame (let it pass unmodified and flush the saved time stamp in the time stamp block).

The following full calculations are performed:

- Sync frames: Correction field = Internal Correction field + (Raw\_Timestamp\_ns + Local\_correction)
- Pdelay\_req frames: Correction field = Internal Correction field + (Raw\_Timestamp\_ns + Local\_correction) – Reserved\_bytes – Asymmetry
- Pdelay\_resp frames: Correction field = Original Correction field + (Raw\_Timestamp\_ns + Local\_correction) – Reserved\_bytes

### 3.6.8.4 Ingress, Mode B

If the analyzer detects that the frame is an IEEE 1588 Sync frame belonging to the PTP domain(s) of system, it signals to the time stamp block which action to perform (subtract\_p2p), along with the correction field of the frame. It also delivers the write offset and data size (location of the correction field inside the frame, 8 bytes wide) to the rewriter.

If the analyzer detects that the frame is an IEEE 1588 Pdelay\_req frame belonging to the PTP domain(s) of system, it signals to the time stamp block which action to perform (Write). It also delivers the write offset and data size (location of the reserved 4 bytes in the PTP header we use to save the ns part of the Rx time stamp, 4 bytes wide) to the rewriter.

If the analyzer detects that the frame is an IEEE 1588 Pdelay\_resp frame belonging to the PTP domain(s) of system, it signals to the time stamp block which action to perform (Write). It also delivers the write offset and data size (location of the reserved 4 bytes in the PTP header we use to save the ns part of the Rx time stamp, 4 bytes wide) to the rewriter.

If the time stamp block gets the Subtract\_p2p action, it subtracts the value in the active\_timestamp\_ns\_p2p register from the correction\_field data and outputs the value on the New\_Field bus to the Rewriter block.

If the time stamp block gets the Write action, it outputs the value of the active\_timestamp\_ns register on the New\_field bus to the Rewriter block.

The following full calculations are performed:

- Sync frames: Internal Correction field = Original Correction field – (Raw\_Timestamp\_ns – Local\_correction) + Path\_delay + Asymmetry
- Pdelay\_req frames: Reserved\_bytes = Raw\_Timestamp\_ns – Local\_correction
- Pdelay\_resp frames: Reserved\_bytes = Raw\_Timestamp\_ns – Local\_correction + Asymmetry

### 3.6.8.5 Egress, Mode B

If the analyzer detects that the frame is an IEEE 1588 Sync frame belonging to the PTP domain(s) of the system, it signals to the time stamp block which action to perform (Add), along with the correction field of the frame. It also delivers the write offset and data size (location of the correction field inside the frame, 8 bytes wide) to the rewriter.

If the analyzer detects that the frame is an IEEE 1588 Pdelay\_req frame belonging to the PTP domain(s) of the system, it signals to the time stamp block which action to perform (Write, Save), along with the original correction field of the frame (will have the value of 0). It also delivers the write offset and data size (0 No data is actually written into the frame) to the rewriter. In addition, it outputs the field that holds the frame identifier (sequenceld from the PTP header) to the time stamp FIFO, to save along with the Tx time stamp.

If the analyzer detects that the frame is an IEEE 1588 Pdelay\_resp frame belonging to the PTP domain(s) of system, it signals to the time stamp block which action to perform (Add - this requires that the IEEE 1588 engine has subtracted the Rx time stamp from the correction field), along with the original correction field of the frame. It also delivers the write offset and data size (location of the correction field inside the frame, 8 bytes wide) to the rewriter.

If the time stamp block gets the Write, Save action, it outputs the value of the active\_timestamp\_ns register on the New\_field bus to the Rewriter block and sets the save\_timestamp bit.

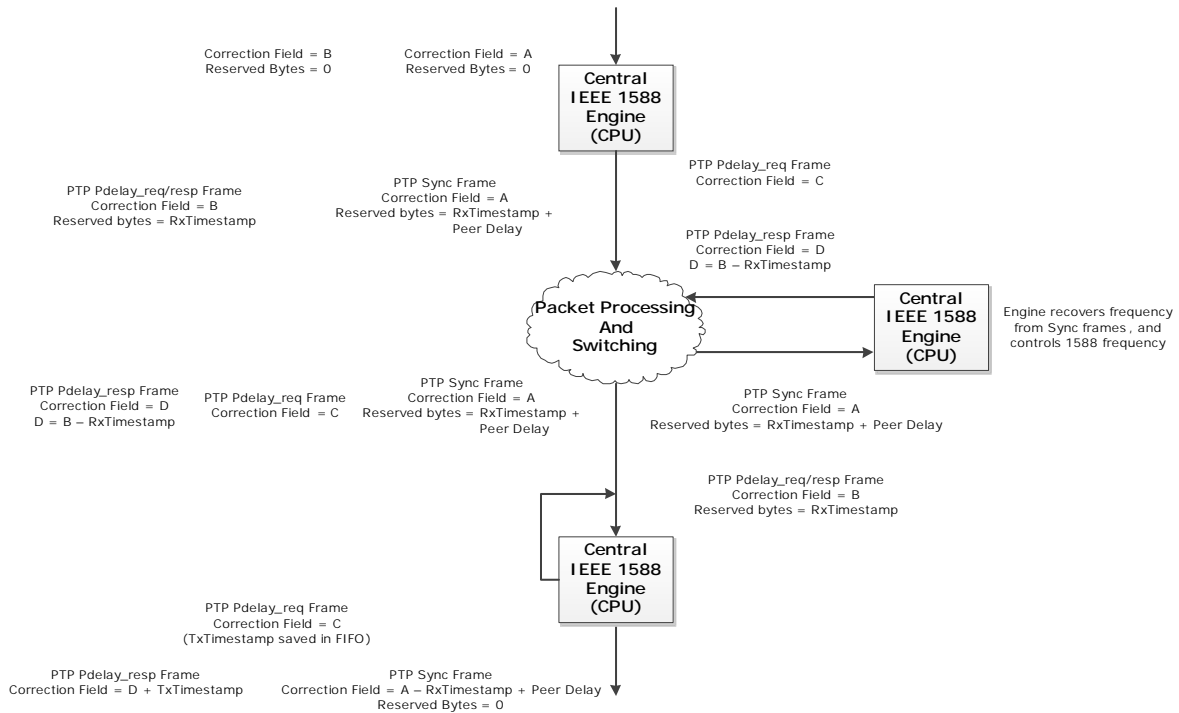
If the time stamp block gets the Add action, it adds the correction field value to the value in the active\_timestamp\_ns register and outputs the value on the New\_Field bus to the Rewriter block.

The Tx time stamp FIFO block contains an (implementation specific) amount of buffer memory. It simply stores the Tx time stamp values that it receives from the time stamp block together with the frame identifier data it receives from the Analyzer block and has a CPU interface that allows the IEEE 1588 engine to read out the time stamp sets (Frame identifier + New Tx time stamp).

The following full calculations are performed:

- Sync frames: Correction field = Internal Correction field + (Raw\_Timestamp\_ns + Local\_correction)
- Pdelay\_req frames: FIFO = Raw\_Timestamp\_ns + Local\_correction – Asymmetry
- Pdelay\_resp frames: Correction field = Internal Correction field + (Raw\_Timestamp\_ns + Local\_correction)

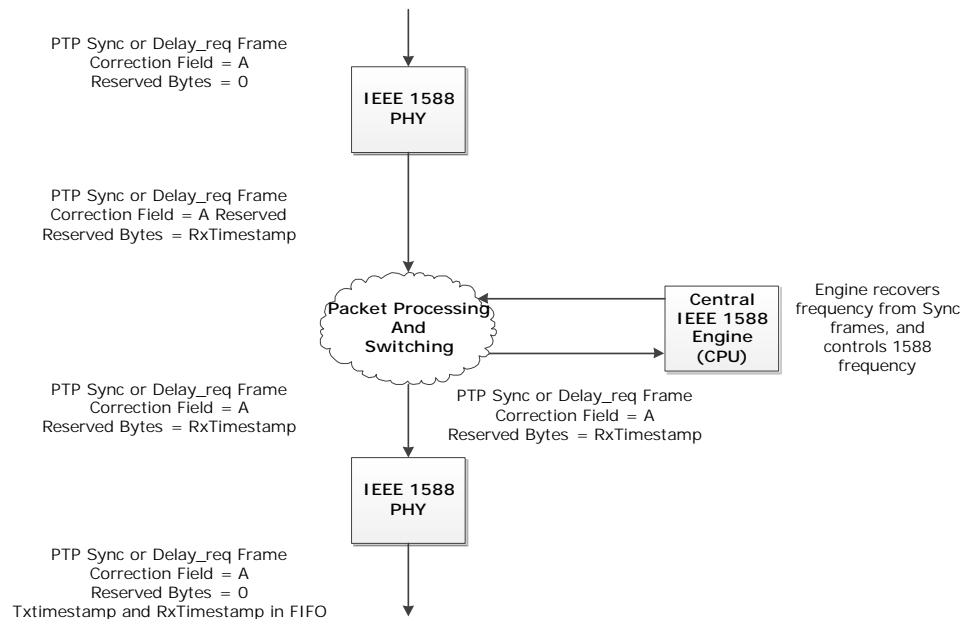
**Figure 26 • One-Step Peer-to-Peer Transparent Clock Mode B**



### 3.6.9 Supporting Two-Step Transparent Clock

In two-step transparent clocks, the Rx and Tx time stamps are saved for the IEEE 1588 engine to read and the follow-up message is redirected to the IEEE 1588 engine so that it can update the correction field with the residence time.

Even though two-step transparent clocks can be used with this architecture, it is also possible to process the frames in the same manner as a one-step TC, because the slaves are required to take both the correction fields from the Sync frames and the follow-up frames into account. This significantly reduces the CPU load for the TC. The following illustration shows two-step transparent clock normal operation.

**Figure 27 • Two-Step End-to-End Transparent Clock**

### 3.6.9.1 Ingress

If the analyzer detects that the frame is an IEEE 1588 Sync or Delay\_req frame belonging to the PTP domain(s) of the system, it signals to the time stamp block which action to perform (Write). The analyzer also delivers the write offset and data size to the rewriter (four reserved bytes in the PTP header, which will be passed out on the egress port of the system). A changed reserved value may be significant in security protection. This method allows the frames to be copied to the IEEE 1588 engine, so that it can extract the Rx time stamp and that it knows that it needs to read the Tx time stamps to be ready for the follow up message. It is also possible to save the Rx time stamp value along with the Tx time stamp in the Tx time stamp FIFO.

If the time stamp block gets the Write action, it outputs the current time stamp to the rewriter and the rewriter writes the ns part of the time stamp into the reserved bytes and recalculates FCS.

The following full calculations are performed:

- Sync frames:  $\text{Reserved\_bytes} = (\text{Raw\_Timestamp\_ns} - \text{Local\_correction})$   
Correction field = Original Correction field + Asymmetry
- Delay\_req frames:  $\text{Reserved\_bytes} = \text{Raw\_Timestamp\_ns} - \text{Local\_correction}$

### 3.6.9.2 Egress

If the analyzer detects that the frame is an IEEE 1588 Sync or Delay\_req frame belonging to the PTP domain(s) of the system, it signals to the time stamp block which action to perform (Write, Save). The analyzer also delivers the write offset and data size (but as nothing is to be overwritten the values will be 0) to the rewriter. The analyzer outputs 10 bytes of frame identifier to the Tx time stamp FIFO to be saved along with the Tx time stamp. The frame identifier must include, at minimum, the sequenceld field so the CPU can match the time stamp with the follow-up frame. The analyzer also outputs the offset for the reserved fields in the PTP header to the rewriter, so that the rewriter field is reset to 0 and the temporary Rx time stamp value is cleared.

If the time stamp block gets the Write, Save action it outputs the current time stamp value to the rewriter (and time stamp FIFO) and sets the save\_timestamp bit. The time stamp FIFO block saves the New\_field data along with the frame identifier data it received from the analyzer block. The frame identifier data that is saved can contain the reserved field in the PTP header that was written with the Rx time stamp, so that the CPU now can read the set of Tx and Rx time stamp from the Tx time stamp FIFO.

The following full calculations are performed:

- Sync frames: FIFO = Raw\_Timestamp\_ns + Local\_correction (reserved\_bytes containing the Rx time stamp saved together with Tx time stamp)
- Delay\_req frames: FIFO = Raw\_Timestamp\_ns + Local\_correction – Asymmetry (reserved\_bytes containing the Rx time stamp saved together with Tx time stamp)

### 3.6.10 Calculating OAM Delay Measurements

Frame delay measurements can be made as one-way and two-way delay measurements. Microsemi recommends that the delay measurement be measured before the packets enter the queues, if the purpose is to measure the delay for different priority traffic, but it can be used with time stamping in the PHY to measure the delay through the network devices placed in the path between the measurement points.

The function is mainly an on-demand OAM function, but it can run continuously.

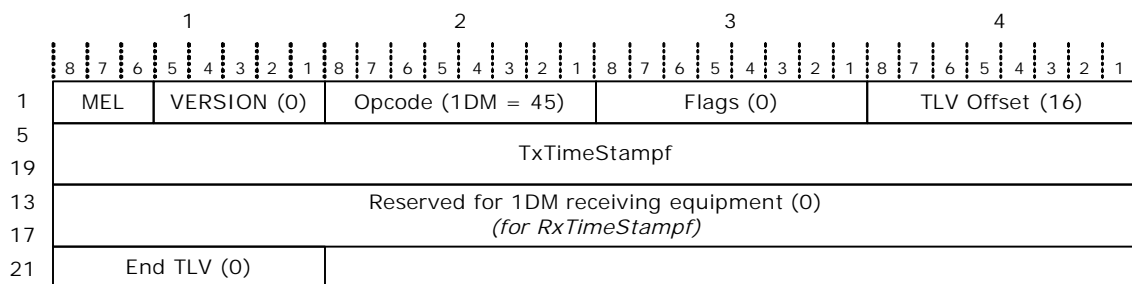
### 3.6.11 Supporting Y.1731 One-Way Delay Measurements

One-way delay measurements require that the two peers are synchronized in time. When they are not synchronized, only frame delay variations can be measured.

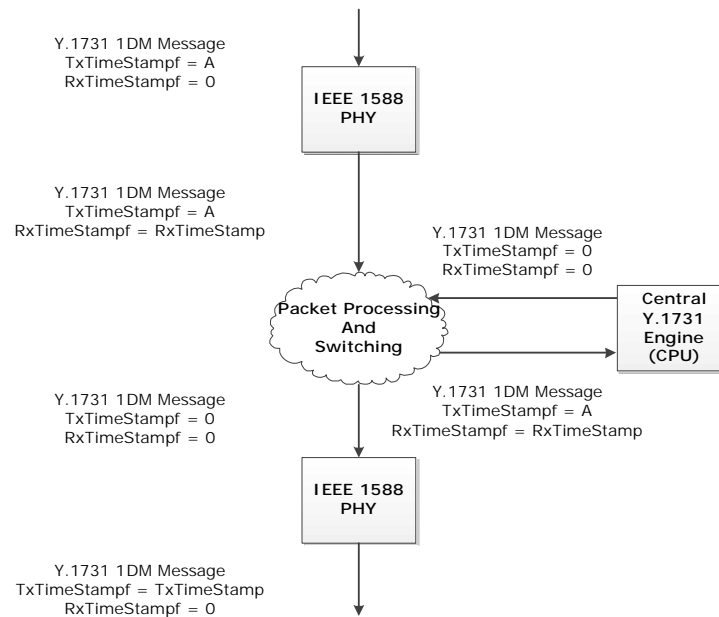
The MEP periodically sends out 1DM OAM frames containing a TxTimeStampf value in IEEE 1588 format.

The receiver notes the time of reception of the 1DM frame and calculates the delay.

Figure 28 • Y.1731 1DM PDU Format



1. For one-way delay measurements, both MEPs must support IEEE 1588 and be in sync.
2. 1DM frame is generated by the CPU, but with an empty Tx time stamp.
3. The frame is transmitted by the initiating MEP.
4. The 1DM frame is classified as an outgoing 1DM frame by the egress PHY and the PHY rewrites the frame with the time as TxFCf.
5. The receiving PHY classifies the incoming 1DM frame and writes the receive time stamp in reserved place (RxTimeStampf).
6. The frame is received by the peer MEP.
7. The frame is forwarded to the CPU that can calculate the delay.

**Figure 29 • Y.1731 One-Way Delay**

### 3.6.11.1 Ingress

If the analyzer detects that the frame is a Y.1731 1DM PDU frame belonging to the MEP, it signals to the time stamp block which action to perform (Write). The analyzer also delivers the write offset and data size (location of the RxTimeStamp location in the frame, 8 bytes wide) to the rewriter.

If the time stamp block gets the Write action, it delivers the time stamp to the rewriter block and the rewriter block adds this time stamp to the reserved bytes in the frame and recalculates FCS.

The following calculation is performed for 1DM frames:

$$\text{RxTimeStamp} = (\text{Raw\_Timestamp} - \text{Local\_correction})$$

### 3.6.11.2 Egress

If the analyzer detects that the frame is a Y.1731 1DM PDU frame belonging to the MEP, it signals to the time stamp block which action to perform (Write). It also delivers the write offset and data size (location of the TxTimeStamp location in the frame, 8 bytes wide) to the rewriter.

If the time stamp block gets the Write action, it delivers the time stamp to the rewriter block and the rewriter block adds this time stamp to the reserved bytes in the frame and recalculates FCS.

The following calculation is performed for 1DM frames:

$$\text{TxTimeStamp} = (\text{Raw\_Timestamp} + \text{Local\_correction})$$

## 3.6.12 Supporting Y.1731 Two-Way Delay Measurements

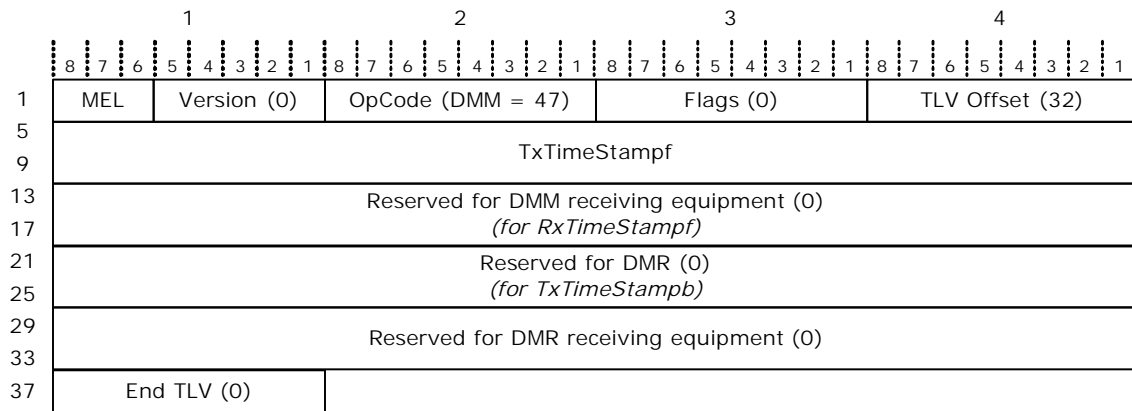
When performing two-way delay measurements, the initiating MEP transmits DMM frames containing a TxTimeStamp value. The receiving MEP replies with a DMR frame that is the same as the DMM frame, but with destination and source MAC address swapped and with a different OAMPDU opcode.

When the DMR frame is received back at the initiating MEP, the time of reception is noted and the total delay is calculated.

As an option, it is allowed to include two additional time stamps in the DMR frame: RxTimeStampb and TxTimeStampb. These contain the time that the DMM page is received for processing and the time the responding DMR reply is sent back, both in IEEE 1588 format.

Including these time stamps allows for the exclusion of the processing time in the peer MEP, but it does not require that the two MEPs are synchronized.

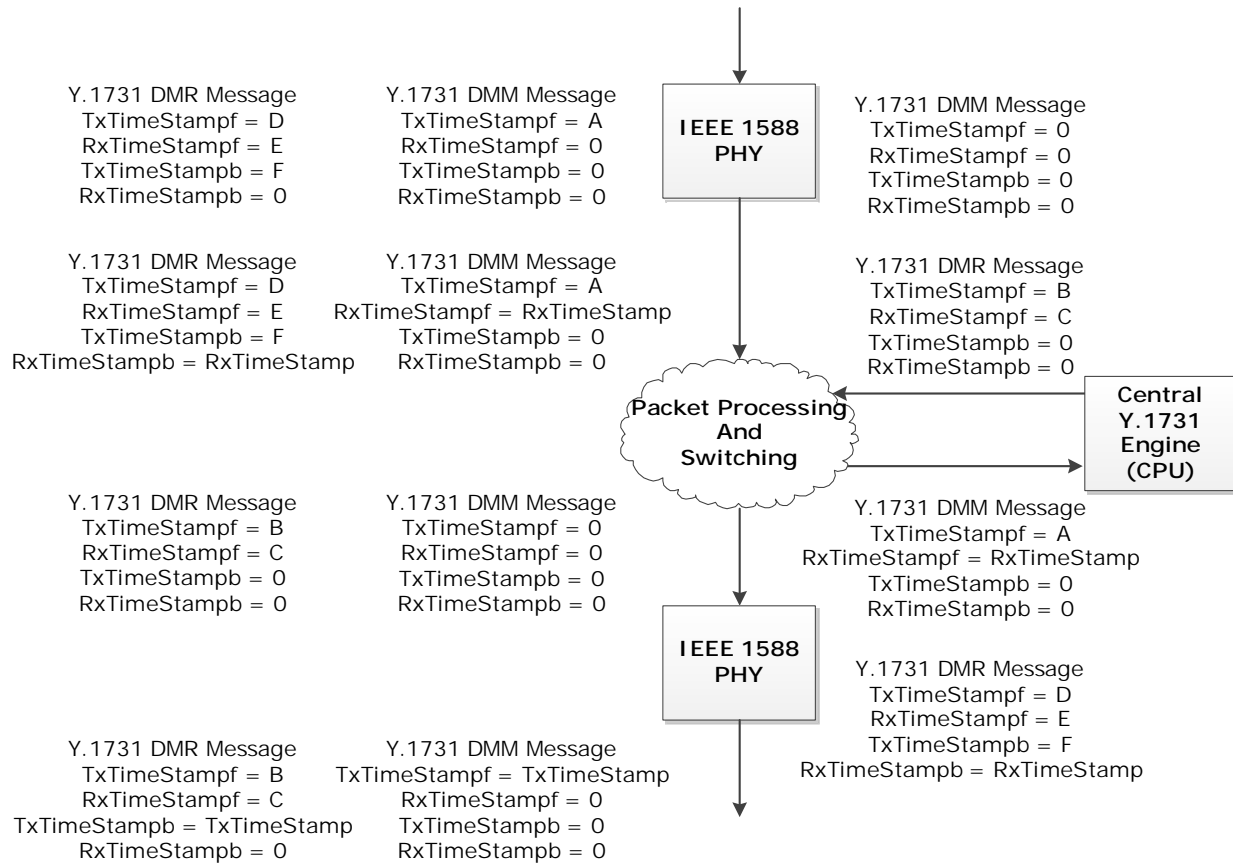
**Figure 30 • Y.1731 DMM PDU Format**



In that case, the following frame flow is needed (two-way delay measurement):

1. DMM frame is generated by the CPU (initiating MEP), but with an empty Tx time stamp.
2. In the egress PHY the DMM frame is classified as an outgoing DMM frame from the MEP and the PHY rewrites the frame with the time as TxTimeStampf.
3. In the ingress PHY the frame is classified as an incoming DMM belonging to the MEP and the RxTimeStampf in the frame is written (the frame has a reserved space for this).
4. The DMM frame is forwarded to the MEP (CPU).
5. The CPU processes the frame (swaps SA/DA MAC addresses, modifies the opcode to DMT) and sends out a DMT frame.
6. The outgoing DMT frame is detected in the egress PHY and the TxTimeStampb is written into the frame.
7. In the ingress PHY the frame is classified as an incoming DMT belonging to the MEP and the RxTimeStampb in the frame is written (the frame has a reserved space for this).
8. The frame is forwarded to the CPU that can calculate the delays.

**Figure 31 • Y.1731 Two-Way Delay**



### 3.6.12.1 Ingress

If the analyzer detects that the frame is a Y.1731 DMM PDU frame belonging to the MEP, it signals to the time stamp block which action to perform (Write). It also delivers the write offset and data size (location of the RxTimeStampf location in the frame, 8 bytes wide) to the rewriter.

If the analyzer detects that the frame is a Y.1731 DMT PDU frame belonging to the MEP, it signals to the time stamp block which action to perform (Write). It also delivers the write offset and data size (location of the RxTimeStampf location in the frame, 8 bytes wide) to the rewriter.

If the time stamp block gets the Write action, it delivers the time stamp to the rewriter block and the rewriter block adds this time stamp to the reserved bytes in the frame and recalculates FCS.

The following calculations are performed:

- DMM frames: RxTimeStampf = (Raw\_Timestamp – Local\_correction)
- DMR frames: RxTimeStampb = (Raw\_Timestamp – Local\_correction)

### 3.6.12.2 Egress

If the analyzer detects that the frame is a Y.1731 DMM PDU frame belonging to the MEP, it signals to the time stamp block which action to perform (Write). It also delivers the write offset and data size (location of the TxTimeStampf location in the frame, 8 bytes wide) to the rewriter.

If the analyzer detects that the frame is a Y.1731 DMT PDU frame belonging to the MEP, it signals to the time stamp block which action to perform (Write). It also delivers the write offset and data size (location of the TxTimeStampb location in the frame, 8 bytes wide) to the rewriter.

If the time stamp block gets the Write action, it delivers the time stamp to the rewriter block and the rewriter block adds the time stamp to the reserved bytes in the frame and recalculates FCS as follows:



- DMM frames: TxTimeStampf = (Raw\_Timestamp + Local\_correction)
- DMR frames: TxTimeStampb = (Raw\_Timestamp + Local\_correction)

### 3.6.12.3 Supporting MPLS-TP One-Way and Two-Way Delay Measurements

MPLS-TP one- and two-way delay measurement are defined in RFC6374 (G.8113.2) and G.8113.1 (draft-bhh). These mechanisms are similar to the ones described for Y.1731 Ethernet OAM delay measurement except for the encapsulations. The following illustrations show the PDU formats.

Figure 32 • RFC6374 DMM/DMR OAM PDU Format

ETH (1)		14/18/22B
MPLS labels (2)		4/8/12/16B
ACH		4B
DMM/DMR OAM PDUs	OAM PDU Header	8B
	Time stamp 1	8B
	Time stamp 1	8B
	Time stamp 1	8B
	Time stamp 1	8B
	padding	(variable size)
FCS		4B

(1) 0, 1, or 2 VLAN tags  
(2) Up to 4 MPLS labels

Figure 33 • Draft-bhh DMM/DMR/1DM OAM PDU Formats

DMM/DMR		1DM	
ETH (1)		14/18/22B	14/18/22B
MPLS labels (2)		4/8/12/16B	4/8/12/16B
ACH		4B	4B
DMM/DMR OAM PDUs	OAM PDU Header	8B	8B
	Time stamp 1	8B	8B
	Time stamp 1	8B	8B
	Time stamp 1	8B	8B
	Time stamp 1	8B	8B
	End TLV indicator	1B	1B
FCS		4B	4B

(1) 0, 1, or 2 VLAN tags  
(2) Up to 4 MPLS labels

### 3.6.13 Device Synchronization for IEEE 1588 Support

It is important to keep all the local clock blocks synchronized to the accurate time over a complete system. To maintain ns accuracy, the signal routing and internal signal delays must be taken into account when configuring a system.

The architecture described in this document assumes that there is a global synchronous clock available in the system. If the system is a telecom system where the system is locked to a PRC, the system clock can be adjusted to match the PRC, meaning that once locked, the frequency of the system clock ensures that the local clocks are progressing (counting) with the accurate frequency. This system clock can be locked to the PRC using IEEE 1588, SyncE, SDH, or by other means.

A global timing signal must also be distributed to all the devices. This could be a 1 pps pulse or another slow synchronization pulse, like a 4 kHz synchronization frequency. It can also just be a one-shot pulse. The system CPU can load each local counter with the time value that happens next time the synchronization pulse goes high (+ the known delay of the synchronization pulse traces). It can also just load the same approximate time value into all the local clock blocks (again + the known delay of the synchronization pulse traces) and load them in parallel. Then the local time can be adjusted to match the actual time by adjusting the local clock blocks using the  $\pm 1$  ns function.

If the Save signal is triggered synchronously on all PHYs of the system, software can read the saved time stamp in each PHY and correct the time accordingly. On a blade with multiple PHYs, it is possible to connect the 1588\_PPS\_1 pin on one PHY to the 1588\_LOAD\_SAVE pin on the next PHY. If the routing delay (both internal chip delay and trace delay) is known, Microsemi recommends that the value saved in the next PHYs correspond to this delay.

If the global system clock is not synchronous, the PPM offset between system clock and the IEEE 1588 time progress can be calculated. This PPM offset can be used to calculate how many local-time-clocks it takes to reach a time offset of 1 ns and this value can be programmed into each local time block. The CPU still need to keep track of the smaller PPM offset and adjust the local time blocks with  $\pm$  writes when necessary.

By measuring the skew between the 1 pps test output from each PHY, it is possible to measure the nominal correction values for the time counters in a system. These can be incorporated into the software of the system. Variations from system to system and temperature variations should be minimized by design.

### 3.6.14 Time Stamp Update Block

The IEEE 1588 block is also called the Time Stamp Update block (TSU) and supports the implementation of IEEE 1588v2 and ITU-T Y.1731 in PHY hardware by providing a mechanism for time stamp update (PTP) and time stamping (OAM).

The TSU block works with other blocks to identify PTP/OAM messages, process these messages, and insert accurate time stamp updates/time stamps where necessary. For IEEE 1588 timing distribution the VSC8257-01 device supports ordinary clocks, boundary clocks, end-to-end transparent clocks, and peer-to-peer transparent clocks in a chassis based IEEE 1588 capable system. One-step and two-step processing is also supported. For details on the timing protocol, refer to IEEE 1588v2. For OAM details refer to ITU-T Y.1731 and G.8113.1/G.8113.2. The TSU block implements part of the functionality required for full IEEE 1588 compliance.

The IEEE 588 protocol has four different types of messages that require action by the TSU: Sync, Delay\_req, Pdelay\_req, and Pdelay\_resp. These frames may be encapsulated in other protocols, several layers deep. The processor is able to detect PTP messages within these other protocols. The supported encapsulations are as follows:

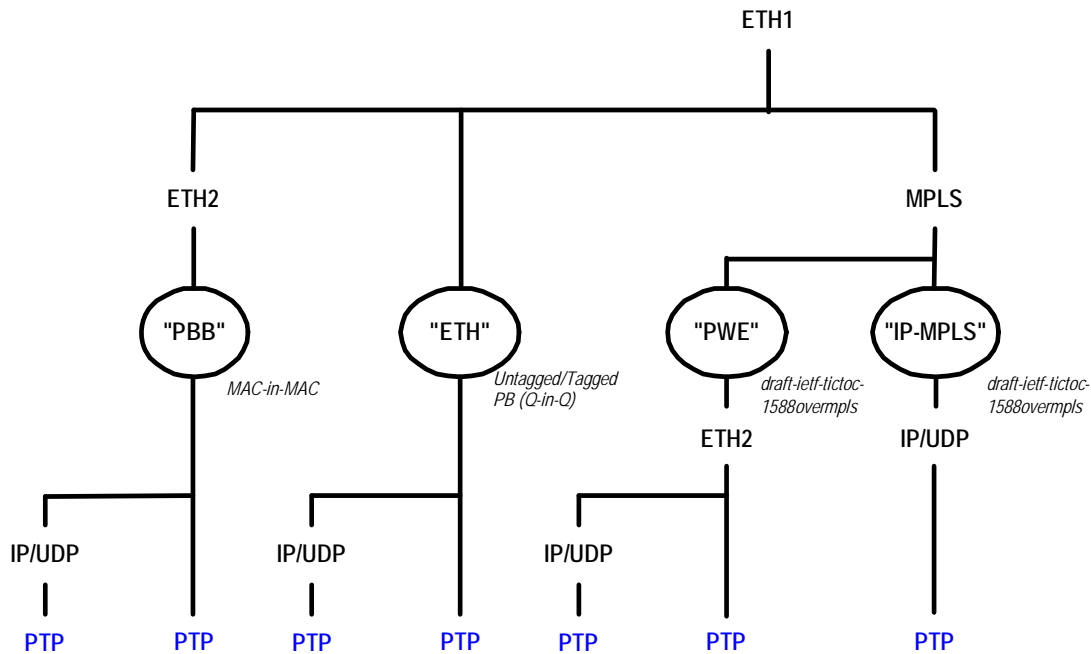
- Ethernet
- UDP over IPv4
- UDP over IPv6
- MPLS
- Pseudo-wires
- PBB and PBB-TE tunnels

OAM frames for delay measurement (1DM, DMM, and DMR) with the following supported encapsulations:

- Ethernet (Y.1731 Ethernet OAM)
- Ethernet in MPLS pseudo-wires (Y.1731 Ethernet OAM)
- MPLS-TP (G.8113.1 (~draft-bhh-mlps-tp-oam-y1731) and G.8113.2 (RFC6374))

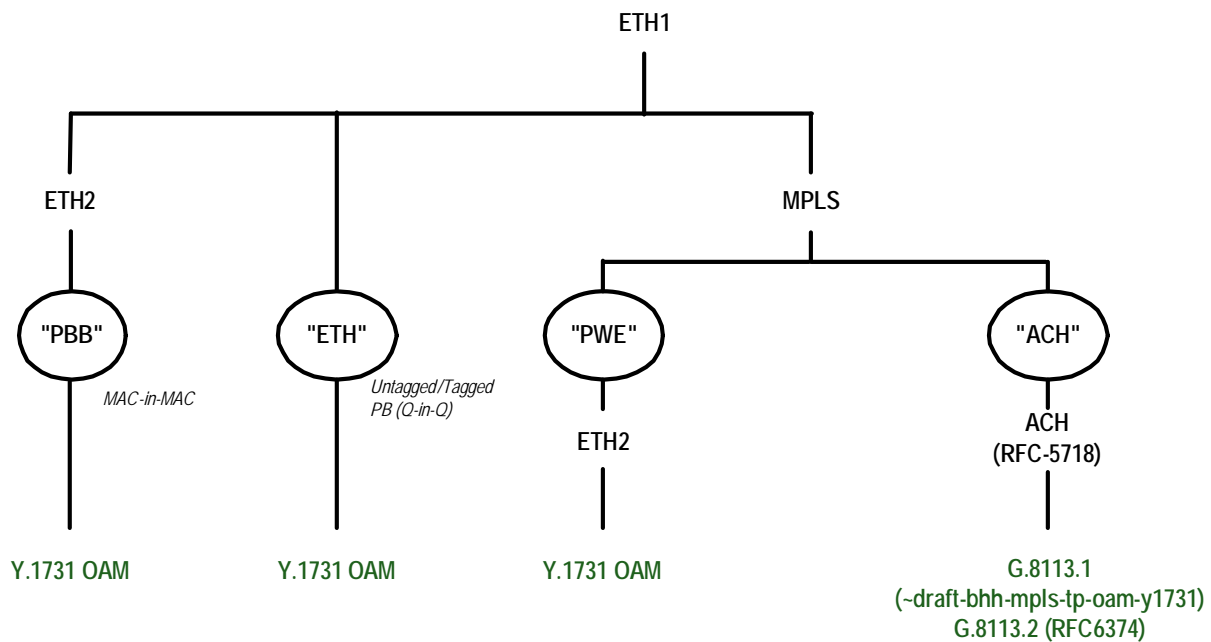
The following illustration shows an overview of the supported PTP encapsulations. Note that the implementation is flexible such that encapsulations not defined here may also be covered.

Figure 34 • PTP Packet Encapsulations



The following illustration shows the same overview of the supported encapsulations with the focus on OAM.

Figure 35 • OAM Packet Encapsulations



There is one TSU per channel in the VSC8257-01 device. The TSU detects and updates up to three different encapsulations of PTP/OAM. Non-matching frames are transferred transparently. This includes IFG, preamble, and SFD. For all frames there is no bandwidth expansion/shrink.

Once these frames are detected in the receive path, they are stamped with the ingress time and forwarded for further PTP/OAM processing. In the transmit path, the correction field of the appropriate PTP message (or the Rx and Tx fields of the OAM frame) is updated with the correct time stamp. A local

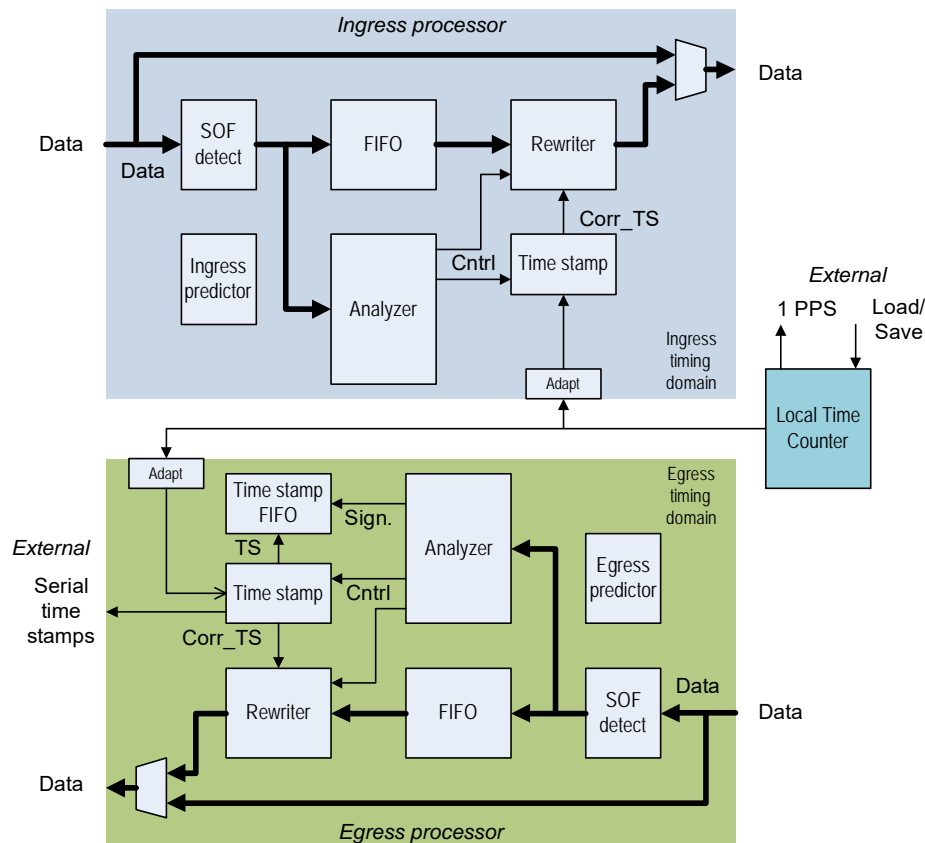
time counter is maintained to provide the time stamps. Implementation of some of the IEEE 1588 protocol requires interaction with the TSU block over the CPU interface and external processing.

The system has an ingress processor, egress processor, and a local time counter. The ingress and egress processing logic blocks are identical except that the time stamp FIFO is only required in the egress direction because the CPU needs to know the actual time stamps of some of the transmitted PTP frames. The CPU reads the time stamps and any associated frame information out of the time stamp FIFO. The FIFO saves the generated time stamps along with information that uniquely identifies the frame to be read out by the CPU.

The ingress and egress processing blocks run on the same clock as the data paths for the corresponding directions. The local time counter is the primary reference clock for the system and it maintains the local reference time used by the TSU logic. It should be synchronized by an external entity. The block provides a method to load and view its value when the 1588\_LOAD\_SAVE pin is asserted. The block also provides a one pulse-per-second output signal with a programmable duty cycle. The local time counter runs at several clock frequencies.

The following illustration shows the block diagram of the TSU.

**Figure 36 • TSU Block Diagram**



In both directions, the input data from the PHY layer is first fed to an SOF detect block. Data is then fed to both the programmable time-delay FIFO and the analyzer. The FIFO delays the data by the time needed to complete the operations necessary to update the PTP frame. That is, the data is delayed to the input of the rewriter so that the rewriter operations are known when the frame arrives. This includes the analyzer and time stamp processor block's functions.

The analyzer block checks the data stream and searches for PTP/OAM frames. When one is detected, it determines the appropriate operations to be performed based on the operating mode and the type of frame detected.

**Note:** The analyzer blocks of two channels share configuration registers and have identical setups.

The time stamp block waits for an SOF to be detected, captures a time stamp from the local time counter, and builds the new time stamp that is to be written into the PTP/OAM frame. Captured time stamps can be read by the CPU.

The rewriter block handles the actual writing of the new time stamp into the PTP/OAM frame. It is also able to clear parts of the frame such as the UDP checksum, if required, or it can update the frame to ensure that the UDP checksum is correct (for IPv6 PTP frames). The block also calculates the new FCS to be written to the PTP frame after updating the fields with the new time stamp.

The VSC8257-01 device has variable latency in the PCS block. These variations are predicted and used to compensate/maximize the accuracy of the IEEE 1588 time stamp logic.

If the time stamp update function is not used the block can be bypassed. When the TSU is bypassed, the block can be configured and then enabled and taken out of bypass mode. The change in bypass mode takes effect only when an IDLE is in the bypass register. This allows the TSU block to be switched on without corrupting data.

Each direction of the IEEE 1588 can be bypassed individually by programming the INTERFACE\_CTL.SPLIT\_BYPASS bit. Bypass is then controlled by INTRERFACE\_CTL.INGR\_BYPASS and INTERFACE\_CTL.EGR\_BYPASS.

Pause frames pass unmodified through the TSU, but the latency may cause a violation of the allowed pause flow-control latency limits per IEEE 802.3.

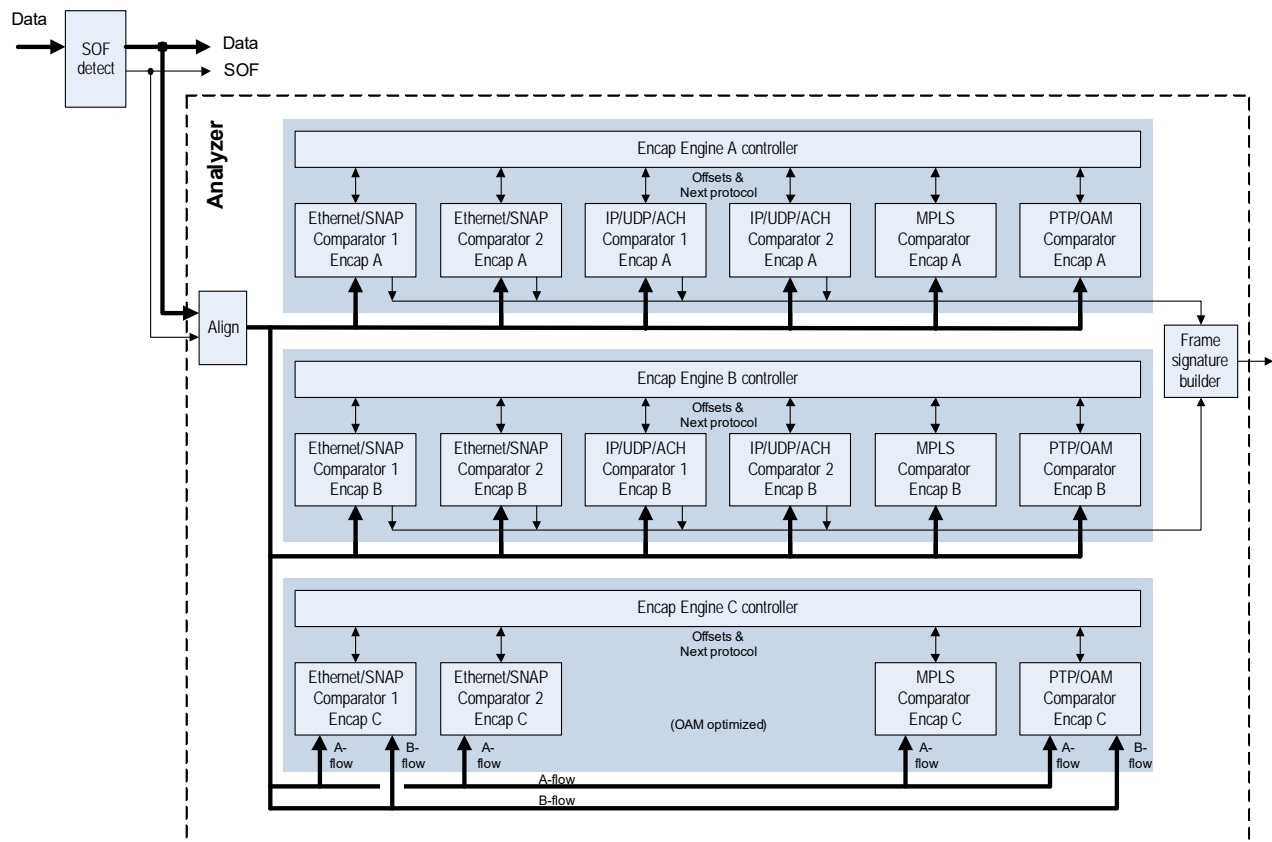
### 3.6.15 Analyzer

The packet analyzer parses incoming packets looking for PTP/OAM frames. It determines the offset of the correction field within the packet for all PTP frames/for the time stamp in Y.1731 OAM frames. The analyzer has the following characteristics:

- Can compare against two different filter sets plus one optimized for OAM
- Each filter targets PTP or OAM frames
- Flexible comparator sequence with fixed start (Ethernet/SNAP) and end (PTP/OAM) comparator. Configurable intermediate comparators (Ethernet/SNAP, 2x IP/UDP/ACH, and MPLS)

The following illustration shows a block diagram of the analyzer.

Figure 37 • Analyzer Block Diagram



The analyzer process is divided into engines and stages. Each engine represents a particular encapsulation stack that must be matched. There are up to six stages in each engine. Each stage uses a comparator block that looks for a particular protocol. The comparison is performed stage-by-stage until the entire frame header has been parsed.

Each engine has its own master enable, so that it can be shut down for major reconfiguration, such as changes in encapsulation order, without stopping traffic. Other enabled engines are not affected.

The SOF detect block searches for the SFD in the preamble and uses that to indicate the SOF position. This information is carried along in the pipeline and also passed to the analyzer.

The first stage of the analyzer is a data path aligner that aligns the first byte of the packet (without the preamble & SFD) to byte 0 of the analyzer data path.

The encapsulation engine handles numerous types of encapsulation stacks. These can be broken down to their individual protocols, and a comparator is defined for each type. The order in which these are applied is configurable. Each comparator outputs a pattern/flow match bit and an offset to the start of the next protocol. The cumulative offset points to the time stamp field.

The sequence in which the protocol comparators are applied is determined by configuration registers associated with each comparator and the transfer of parameters between comparators is controlled by the encapsulation engine controller.

It receives the pattern match and offset information from one comparator stage and feeds the start-of-protocol position to the next comparator. This continues until the entire encapsulation stack has been parsed and always ends with the PTP/OAM stage or until a particular comparator stage cannot find a match in any of its flows. If at any point along the way no valid match is found in a particular stage, the analyzer sends the NOP communication to the time stamp block indicating that this frame does not need modification and that it should discard its time stamp.

There are two types of engines in the analyzer, one optimized for PTP frames and the other optimized for OAM frames. The two engine types are mostly identical except that the IP comparators are removed from the OAM engines. The following table shows the comparator layout per engine type and the number of flows in each comparator. There are two PTP engines and one OAM engine in each analyzer. Additional differences in the Ethernet and MPLS blocks are defined in their respective sections. For more information, see [Ethernet/SNAP/LLC Comparator](#), page 71 and [MPLS Comparator](#), page 75.

**Table 20 • Flows Per Engine Type**

Comparator	Number of Flows	
	PTP Engine	OAM Engine
Ethernet 1	8	8
Ethernet 2	8	8
MPLS	8	8
IP/ACH 1	8	0
IP/ACH 2	8	0
PTP/OAM	6	6

Encapsulation matches can be set independently in each direction by setting the ANALYZER\_MODE.SPLIT\_ENCAP\_FLOW register. However strict and non-strict flow cannot be set independently for group A and group B of analyzer engine C.

Choice of strict flow or non-strict has to be made on each direction rather than on an engine by engine basis. Valid values for INGR\_ENCAP\_FLOW\_ENA and EGR\_ENCAP\_FLOW\_ENA are 3'b000 or 3'b111.

Each comparator stage has an offset register that points to the beginning of the next protocol relative to the start of the current one. The offset is in bytes, and the first byte of the current protocol counts as byte 0. As an example, the offset register for a stage would be programmed to 10 when the header to match is 10 byte long. With the exception of the MPLS stage (offsets are automatically calculated in that stage), it is the responsibility of the programmer to determine the value to put in these registers. This value must be calculated based upon the expected length of the header and is not expected to change from frame-to-frame when matching a given flow.

**Table 21 • Ethernet Comparator: Next Protocol**

Parameter	Width	Description
Encap_Engine_ENA	1 bit	For each encapsulation engine and enable bit that turns the engine on or off. The engine enables and disables either during IDLE (all 8 bytes must be IDLE) or at the end of a frame. If the enable bit is changed during the middle of a frame, the engine will wait until it sees either of those conditions before turning on or off.
Encap_Flow_Mode	1 bit	There is a separate bit for each engine. For each encapsulation engine: 1 = Strict flow matching, a valid frame must use the same flow IDs in all comparators in the engine except the PTP and MPLS comparators. 0 = A valid frame may match any enabled flow in all comparators If more than one encapsulation produces a match, the analyzer sends NOP to the rewriter and sets a sticky bit.

The following table shows the ID codes comparators use in the sequencing registers. The PTP packet target encapsulations require only up to five comparators.

**Table 22 • Comparator ID Codes**

ID	Name	Sequence
0	Ethernet Comparator 1	Must be the first
1	Ethernet Comparator 2	Intermediate
2	IP/UDP/ACH Comparator 1	Intermediate
3	IP/UDP/ACH Comparator 2	Intermediate
4	MPLS Comparator	Intermediate
5	PTP/OAM Comparator	Must be the last

The following sections describe the comparators. The frame format of each comparator type is described first, followed by match/mask parameter definition. All upper and lower bound ranges are inclusive and all match/mask registers work the same way. If the corresponding mask bit is 1, then the match bit is compared to the incoming frame. If a mask bit is 0, then the corresponding match bit is ignored (a wildcard).

### 3.6.15.1 Ethernet/SNAP/LLC Comparator

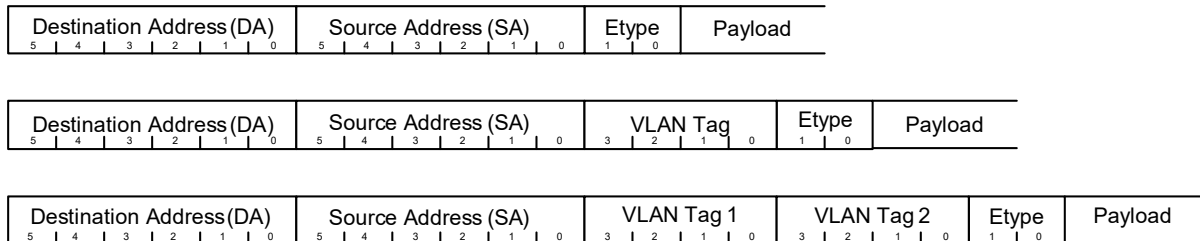
There are two such comparators in each engine. The first stage of each engine is always an Ethernet/SNAP/LLC comparator. The other comparator can be configured to be at any point in the chain.

Ethernet frames can have multiple formats. Frames that have an actual length value in the ether-type field (Ethernet type I) can have one of three formats: Ethernet with an EtherType (Ethernet type II), Ethernet with LLC, or Ethernet with LLC & SNAP. Each of these formats can be compounded by having one or two VLAN tags.

#### 3.6.15.1.1 Type II Ethernet

Type II Ethernet is the most common and basic type of Ethernet frame. The Length/EtherType field contains an EtherType value and either 0, 1, or 2 VLAN tags. Both VLAN can be of type S/C (with EtherType 0x8a88/0x8100). The payload would be the start of the next protocol.

**Figure 38 • Type II Ethernet Basic Frame Format**

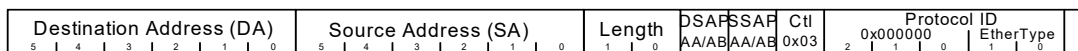


#### 3.6.15.1.2 Ethernet with LLC and SNAP

If an Ethernet frame with LLC contains a SNAP header, it always follows a three-octet LLC header. The LLC values for DSAP & SSAP are either 0xAA or 0xAB and the control field contains 0x03. The SNAP header is five octets long and consists of two fields, the 3-octet OUI value and the 2-octet EtherType. As with the other types of Ethernet frames, this format can have 0, 1, or 2 VLAN tags. The OUI portion of the SNAP header is hard configured to be 0 or 0xf8.

The following illustration shows an Ethernet frame with a length in the Length/EtherType field, an LLC header, and a SNAP header.

**Figure 39 • Ethernet Frame with SNAP**





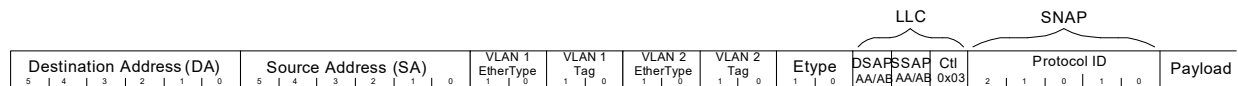
The following illustration shows an Ethernet frame with an LLC/SNAP header and a VLAN tag in the SNAP header. The Ethertype in the SNAP header is the VLAN identifier and tag immediately follows the SNAP header.

**Figure 40 • Ethernet Frame with VLAN Tag and SNAP**



The following illustration shows the longest form of the Ethernet frame header that needs to be supported: two VLAN tags, an LLC header, and a SNAP header.

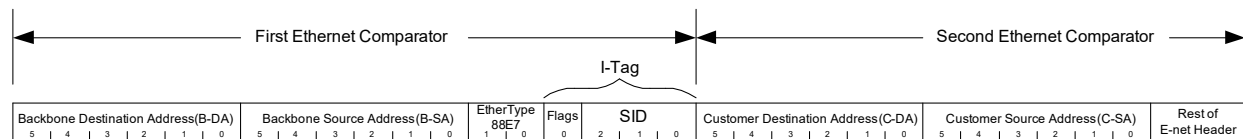
**Figure 41 • Ethernet Frame with VLAN Tags and SNAP**



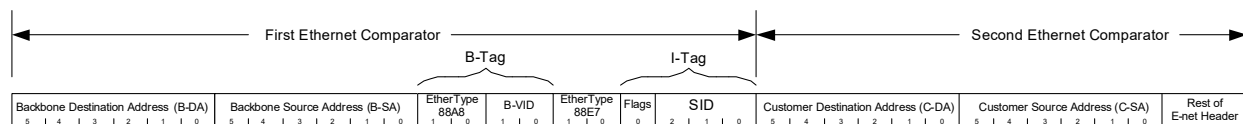
### 3.6.15.1.3 Provider Backbone Bridging (PBB) Support

The provider backbone bridging protocol is supported using two Ethernet comparator blocks back-to-back. The first portion of the frame has a type II Ethernet frame with either 0 or 1 VLAN tags followed by an I-tag. The following illustrations show two examples of the PBB Ethernet frame format.

**Figure 42 • PBB Ethernet Frame Format (No B-Tag)**



**Figure 43 • PBB Ethernet Frame Format (1 B-Tag)**



### 3.6.15.1.4 Ethernet Comparison

The Ethernet comparator block has two forms of comparison, as follows:

- Next protocol comparison is common for all flows in the comparator. It is the single set of registers and is used to verify what the next protocol in the encapsulated stack will be.
- Flow comparison is used to match any of the possible flows within the comparator.

### 3.6.15.1.5 Ethernet Next Protocol Comparison

The next protocol comparison field looks at the last EtherType field in the header (there can be multiple in the header) to verify the next protocol. It may also look at VLAN tags and the EtherType field when it is used as a length. Each has a pattern match/mask or range, and an offset.

The following table lists the next protocol parameters for the Ethernet comparator.

**Table 23 • Ethernet Comparator (Next Protocol)**

Parameter	Width	Description
Eth_Nxt_Comparator	3 bit	Pointer to the next comparator.
Eth_Frame_Sig_Offset	5 bit	Points to the start of the field used to build the frame signature.
Eth_VLAN-TPID_CFG	16 bit	Globally defines the value of the TPID for an S-tag, B-tag, or any other tag type other than a C-tag or I-tag.

**Table 23 • Ethernet Comparator (Next Protocol)**

Parameter	Width	Description
Eth_PBB_ENA	1 bit	Configures if the packet carries PBB or not. This configuration bit is only present in the first Ethernet comparator block. PBB is disabled in Ethernet comparator block 2.
Eth_Etype_Match_Enable	1 bit	Configures if the Ethertype field match register is used or not. Only valid when the packet is a type II Ethernet packet.
Eth_Etype_Match	16 bit	If the packet is a type II Ethernet packet and Eth_Etype_Match_Enable is a 1, the Ethertype field in the packet is compared against this value.

### 3.6.15.1.6 Ethernet Flow Comparison

The Ethernet flow is determined by looking at VLAN tags and either the source address (SA) or the destination address (DA). There are a configurable number of these matched sets. The following table lists the flow parameters for the Ethernet comparator.

**Table 24 • Ethernet Comparator (Flow)**

Parameter	Width	Description
Eth_Flow_Enable	1 bit/flow	0 = Flow disabled 1 = Flow enabled
Eth_Channel_Mask	1 bit/channel/flow	0 = Do not use this flow match group for this channel 1 = Use this flow match group for this channel
Eth_VLAN_Tags	2 bit	Configures the number of VLAN tags in the frame (0, 1, or 2)
Eth_VLAN_Tag1_Type	1 bit	Configures the VLAN tag type for VLAN tag 1 If PBB is not enabled: 0 = C-tag, value of 0x8100 1 = S-tag, match to the value in CONF_VLAN_TPID (global for all ports/directions) If PBB enabled: 0 = S-tag (or B-tag), to the value in CONF_VLAN_TPID (global for all ports/directions) There must be 2 VLAN tags, 1 S-tag and one I-tag 1 = I-tag
Eth_VLAN_Tag2_Type	1 bit	Configures the VLAN tag type for VLAN tag 2 If PBB is not enabled: 0 = C-tag, value of 0x8100 1 = S-tag, match to the value in CONF_VLAN_TPID (global for all ports/directions) If PBB enabled: The second tag is always an I-tag and this register control bit is not used. The second tag in PBB is always an I-tag.

**Table 24 • Ethernet Comparator (Flow)**

Parameter	Width	Description
Eth_Ethertype_Mode	1 bit	0 = Only type 2 Ethernet frames supported, no SNAP/LLC expected 1 = Type 1 & 2 Ethernet packets supported. Logic looks at the Ethertype/length field to determine the packet type. If the field is a length (less than 0x0600), then the packet is a type 1 packet and MUST include a SNAP & 3-byte LLC header. If the field is not a length, it is assumed to be an Ethertype and SNAP/LLC must not be present
Eth_VLAN_Verify_Ena	1 bit	0 = Parse for presence of VLAN tags but do not check the values. For PBB mode, the I-tag is still always checked. 1 = Verify the VLAN tag configuration including number and value of the tags.
Eth_VLAN_Tag_Mode	2 bit	0 = No range checking on either VLAN tag 1 = Range checking on VLAN tag 1 2 = Range checking on VLAN tag 2
Eth_Addr_Match	48 bit	Matches an address field selected by Eth_Addr_Match_Mode
Eth_Addr_Match_Select	2 bit	Selects the address to match 0 = Match the destination address 1 = Match the source address 2 = Match either the source or destination address 3 = Reserved, do not use
Eth_Addr_Match_Mode	3 bits per flow	Selects the address match mode. One or multiple bits can be set in this mode register allowing any combination of match types. For unicast or multicast modes, only the MSB of the address field is checked (0 = unicast; 1 = multicast). See section 3.2.3.1 of 802.3 for more details. 0 = Match the full 48-bit address 1 = Match any unicast address 2 = Match any multicast address
Eth_VLAN_Tag1_Match	12 bit	Match field for the first VLAN tag (if configured to be present).
Eth_VLAN_Tag1_Mask	12 bit	Mask for the first VLAN tag. If a match set is not used, set this register to all 0s.
Eth_VLAN_Tag2_Match	12 bit	Match field for the update VLAN tag (if configured to be present).
Eth_VLAN_Tag2_Mask	12 bit	Mask for the second VLAN tag. If a match set is not used, set this register to all 0s.
Eth_VLAN_Tag_Range_Upper	12 bit	Upper limit of the range for one of the VLAN fields selected by ETH_VLAN_TAG_MODE register. If PBB mode is enabled, this register is not used for range checking but rather is the upper 12 bit of the I-tag.
Eth_VLAN_Tag_Range_Lower	12 bit	Lower limit of the range for one of the VLAN fields selected by ETH_VLAN_TAG_MODE register. If PBB mode is enabled, this register is not used for range checking but rather is the lower 12 bit of the I-tag SID.

**Table 24 • Ethernet Comparator (Flow)**

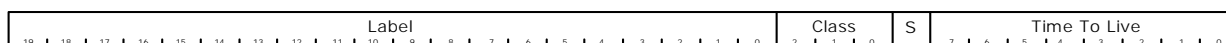
Parameter	Width	Description
Eth_Nxt_Prot_Grp_Sel	1 bit	Per flow, maps a particular flow to a next-protocol group register set. This register only appears in the Ethernet block in the OAM-optimized engine.

If the Ethernet block is part of the OAM optimized engine, there are two sets of next-protocol configuration registers. Both sets are identical except one has an *\_A* suffix and the other has a *\_B* suffix. In the per-flow registers an additional register, *ETH\_NXT\_PROT\_SEL*, is included to map a particular flow with a set of next protocol register set. This function allows the Ethernet block within the OAM-optimized engine to act like two separate engines with a configurable number of flows assignable to each with a total maximum number of eight flows. It effectively allows two separate protocol encapsulation stacks to be handled within the engine.

### 3.6.15.1.7 MPLS Comparator

The MPLS comparator block counts MPLS labels to find the start of the next protocol. The MPLS header can have anywhere from 1 to 4 labels. Each label is 32 bit long and has the format shown in the following illustration.

**Figure 44 • MPLS Label Format**

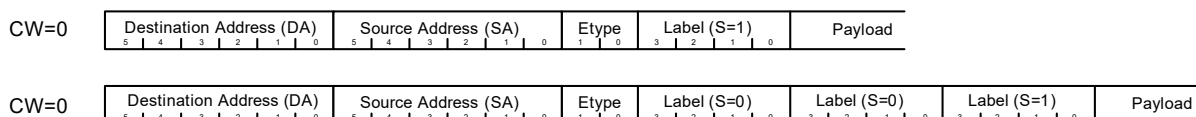


The S bit is used to indicate the last label in the stack, as follows: If S = 0, then there is another label. If S = 1, then this is the last label in the stack.

Also, the MPLS stack can optionally be followed by a control word (CW). This is configurable per flow.

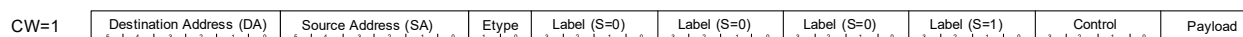
The following illustration shows a simple Ethernet packet with either one label or three labels and no control word.

**Figure 45 • MPLS Label Stack within an Ethernet Frame**



The following illustration shows an Ethernet frame with four labels and a control word. Keep in mind that this comparator is used to compare the MPLS labels and control words; the Ethernet portion is checked in the first stage.

**Figure 46 • MPLS Labels and Control Word**



There could be VLAN tags between the SA and the Etype fields and, potentially, an LLC and SNAP header before the MPLS stack, but these would be handled in the Ethernet/LLC/SNAP comparator.

The only configuration registers that apply to all flows within the comparator are the *match\_mode* register and the *nxt\_comparator* register. The match mode register determines how the match filters are used and there is one per stage. Each flow has its own complete set of match registers.

**Table 25 • MPLS Comparator: Next Word**

Parameter	Width	Description
MPLS_Nxt_Comparator	3 bit	Pointer to the next comparator

**Table 26 • MPLS Comparator: Per-Flow**

Parameter	Width	Description										
MPLS_Flow_Enable	1 bit per flow	0 = Flow disabled 1 = Flow enabled										
MPLS_Channel_Mask	1 bit per channel per flow	0 = Do not use this flow match group for this channel 1 = Use this flow match group for this channel										
MPLS_Ctl_Word	1 bit	Indicates if there is a 32-bit control word after the last label. This should only be set if the control word is not expected to be an ACH header. ACH headers are checked in the IP block. If the control word is a non-ACH control word, only the upper 4 bits of the control are checked and are expected to be 0. 0 = There is no control word after the last label 1 = There is expected to be a control word after the last label										
MPLS_REF_PNT	1 bit	The MPLS comparator implements a searching algorithm to properly parse the MPLS header. The search can be performed from either the top of the stack or the end of the stack. 0 = All searching is performed starting from the top of the stack 1 = All searching is performed from the end of the stack										
MPLS_STACK_DEPT H	4 bit	Each bit represents a possible stack depth, as shown in the following list.										
		<table border="1"> <thead> <tr> <th>MPLS_STACK_DEPTH Bit</th> <th>Allowed Stack Depth</th> </tr> </thead> <tbody> <tr> <td>0</td> <td>1</td> </tr> <tr> <td>1</td> <td>2</td> </tr> <tr> <td>2</td> <td>3</td> </tr> <tr> <td>3</td> <td>4</td> </tr> </tbody> </table>	MPLS_STACK_DEPTH Bit	Allowed Stack Depth	0	1	1	2	2	3	3	4
MPLS_STACK_DEPTH Bit	Allowed Stack Depth											
0	1											
1	2											
2	3											
3	4											

**Table 27 • MPLS Range\_Upper/Lower Label Map**

Parameter	MPLS_REF_PNT = 0, top-of-stack referenced	MPLS_REF_PNT=1, end-of-stack referenced
MPLS_Range_Upper/Lower_0	Top label	Third label before the end label
MPLS_Range_Upper/Lower_1	First label after the top label	Second label before the end label
MPLS_Range_Upper/Lower_2	Second label after the top label	First label before the end label
MPLS_Range_Upper/Lower_3	Third label after the top label	End label

The offset to the next protocol is calculated automatically. It is based upon the number of labels found and whether a control word is configured to be present. It points to the first octet after the last label or after the control word, if present.

**Table 28 • Next MPLS Comparator**

Parameter	Width	Description
MPLS_Range_Lower	20 bit × 4 labels	Lower value of the label range when range checking is enabled
MPLS_Range_Upper	20 bit × 4 labels	Upper value of the label range when range checking is enabled

If an exact label match is desired, set the upper and lower range values to the same value. If a label value is a don't care, then set the upper value to the maximum value and the lower value to 0.

The MPLS comparator block used in the OAM-optimized engine differs from the one used in the PTP-optimized engine.

Just like the Ethernet comparator block, there are two sets of next protocol blocks along with a next protocol association configuration field per-flow. This allows two different encapsulations to occur in a single engine.

**Table 29 • Next-Protocol Registers in OAM-Version of MPLS Block**

Parameter	Width	Description
MPLS_Nxt_Prot_Grp_Sel	1 bit per flow	Maps each flow to next-protocol-register set A or B

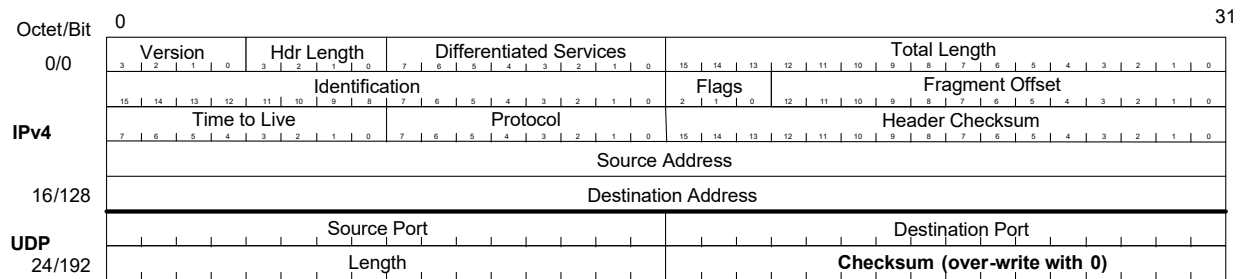
### 3.6.15.2 IP/UDP/ACH Comparator

The IP/UDP/ACH comparator is used to verify one of three possible formats, IPv4, IPv6, and ACH. Additionally, IPv4 and IPv6 can also have a UDP header after the IP header. There are two of these comparators and they can operate at stages 2, 3, or 4 of the analyzer pipeline. Note that if there is an IP-in-IP encapsulation, a UDP header will only exist with the inner encapsulation.

### 3.6.15.3 IPv4 Header Format

The following illustration shows an IPv4 frame header followed immediately by a UDP header. IPv4 does not always have the UDP header, but the comparator is designed to work with or without it. The Header Length field is used to verify the offset to the next protocol. It is a count of 32-bit words and does not include the UDP header. If the IPv4 frame contains a UDP header, the Source and Destination ports are also checked. These values are the same for all flows within the comparator. Note that IPv4 options, extended headers, and UDP fragments are not supported.

**Figure 47 • IPv4 with UDP**

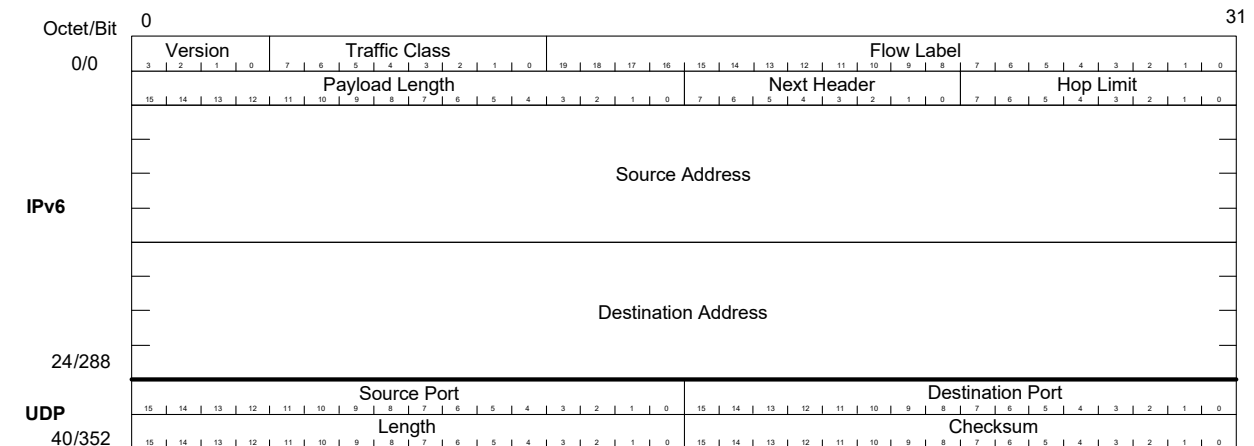


Per flow validation is performed on the Source or Destination Address in the IPv4 header. The comparator can be configured to indicate a match in the flow if the source, destination, or either the source or destination fields match.

### 3.6.15.4 IPv6 Header Format

The following illustration shows an IPv6 frame header followed immediately by a UDP header. IPv6 does not always have the UDP header, but the comparator is designed to work with or without it. The Next Header field is used to verify the offset to the next protocol. It is a count of 32-bit words and does not include the UDP header. If the IPv6 frame contains a UDP header, the Source and Destination ports are also checked. These values are the same for all flows within the comparator.

**Figure 48 • IPv6 with UDP**



Per flow validation is performed on the Source or Destination Address in the IPv6 header. The comparator can be configured to indicate a match in the flow if the source, destination, or either the source or destination fields match.

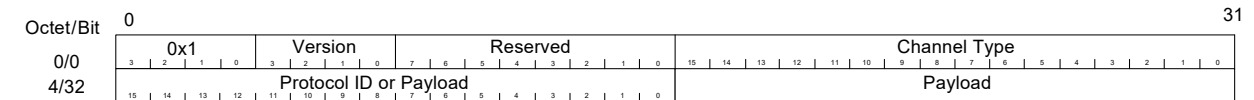
If the IPv6 frame is the inner most IP protocol, then the checksum field must be valid. This is accomplished using a pair of pad bytes after the PTP frame. The checksum is computed using one's compliment of the one's compliment sum of the IPv6 header, UDP header, and payload including the pad bytes. If any of the fields in the frame are updated, the pad byte field must be updated so that the checksum field does not have to be modified.

**Note:** IPv6 extension headers are not supported.

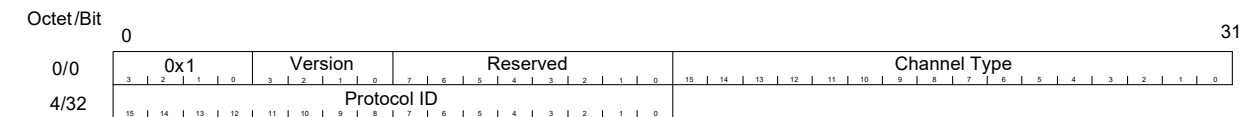
### 3.6.15.5 ACH Header Format

The following illustrations show ACH headers. They can appear after a MPLS label stack in place of the control word. ACH is verified as a protocol only. There are no flows within the protocol for ACH. The ACH header can optionally have a Protocol ID field. The protocol is verified using the Version, Channel Type, and optional Protocol ID field.

**Figure 49 • ACH Header Format**



**Figure 50 • ACH Header with Protocol ID Field**



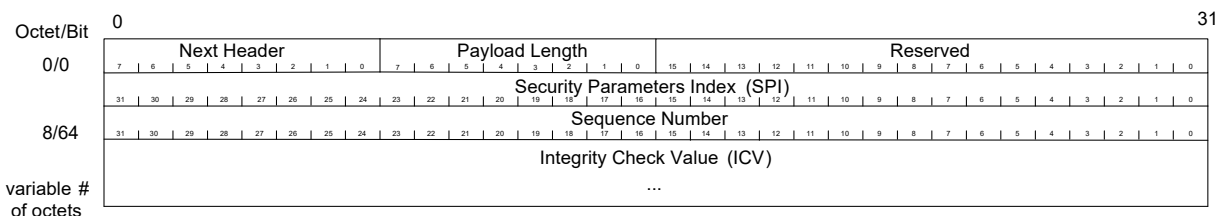
### 3.6.15.6 IPSec

IPSec adds security to the IP frame using an Integrity Check Value (ICV), a variable-length checksum that is encoded with a special key. The key value is known by the sender and the receiver, but not any of the devices in between. A frame must have a correct ICV to be valid. The sequence number field is a continuously incrementing value that is used to prevent replay attacks (resending a known good frame).

Little can be done with frames when IPSec is used because the IEEE 1588 block cannot recalculate the ICV and the frame cannot be modified on egress. Therefore, one-step processing cannot be performed, only two-step processing can be done. The only task here is to verify the presence of the protocol header. Stored time stamps in the TS FIFO are used to create follow-up messages. On ingress, the time stamp can be added to the PTP frame by writing it into the reserved bytes or by overwriting the CRC with it and appending a new CRC. The CPU must know how to handle these cases correctly.

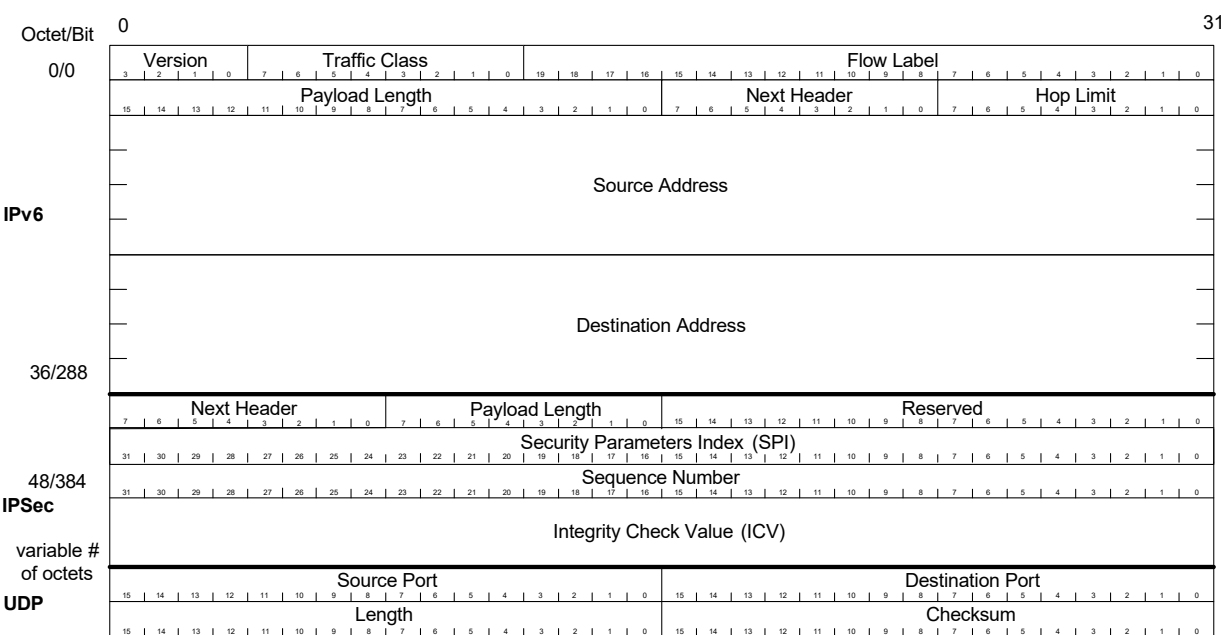
The following illustration shows the format of the IPSec frame. It normally appears between the IP header (IPv4 or IPv6) and the UDP header or at the start of the payload.

**Figure 51 • IPSec Header Format**



There is only one set of match/mask registers associated with IPSec and they are used to verify the presence of the IPSec header. The following illustration shows the largest possible IP frame header with IPv6, IPSec, and UDP.

**Figure 52 • IPv6 with UDP and IPSec**



### 3.6.15.7 Comparator Field Summary

The following table shows a summary of the fields and widths to verify IPv4, IPv6, and ACH protocols.

**Table 30 • Comparator Field Summary**

Protocol	Next Protocol Fields	NPF Bit Widths	Flow Fields	Flow Bit Widths
IPv4	Header length	One 4-bit field	Source/ Destination Address	One 32-bit field
	UDP Source/Destination Port	One 32-bit field		
IPv6	Next header	One 8-bit field	Source/ Destination Address	One 128-bit field
	UDP Source/Destination Port	One 32-bit field		
ACH	Entire ACH header	One 64-bit field		



**Table 30 • Comparator Field Summary**

Protocol	Next Protocol Fields	NPF Bit Widths	Flow Fields	Flow Bit Widths
IPSec	Next Header/Payload Length/ SPI	One 64-bit field		

### 3.6.15.7.1 IP/ACH Comparator Next Protocol

The following table shows the registers used to verify the current header protocol and the next protocol. They are universal and cover IPv4, IPv6, and ACH. They can also be used to verify other future protocols.

**Table 31 • IP/ACH Next-Protocol Comparison**

Parameter	Width	Description
IP_Mode	2 bit	Specifies the mode of the comparator. If IPv4 or IPv6 is selected, the version field is automatically checked to be either 4 or 6 respectively. If another protocol mode is selected, then the version field is not automatically checked. In IPv4, the fragment offset field must be 0, and the MF flag bit (LSB of the flag field) must be 0. 0 = IPv4 1 = IPv6 2 = Other protocol, 32-bit address match 3 = Other protocol, 128-bit address match
IP_Prot_Match_1	8 bit	Match bit for Protocol field in IPv4 or next header field in IPv6
IP_Prot_Mask_1	8 bit	Mask bits for IP_Prot_Match_1. For each bit, if it is a 1, the corresponding match bit is valid. If it is 0, the corresponding match bit is ignored. Disable this match/mask set by setting the mask register to all 0's.
IP_Prot_Offset_1	5 bit	Indicates the starting position relative to the beginning of the IP frame header to start matching for the match/mask 1 register pair.
IP_Prot_Match_2	64 bit	Match bits for the IPSec header or any other desired field. For ACH, this register should be used to match the ACH header.
IP_Prot_Mask_2	64 bit	Mask bits for IP_Prot_Match_2. For each bit, if it is a 1, the corresponding match bit is valid. If it is 0, the corresponding match bit is ignored. Disable this match/mask set by setting the mask register to all 0's.
IP_Prot_Offset_2	7 bit	Indicates the starting position relative to the beginning of the IP frame header to start matching for the match/mask two-register pair.
IP_Nxt_Protocol	8 bit	Points to the start of the next protocol relative to the beginning of this header. It is the responsibility of the programmer to determine this offset, it is not calculated automatically. Each flow within an encapsulation engine must have the same encapsulation order and each header must be the same length. This field is current protocol header length in bytes.
IP_Nxt_Comparator	3 bit	Pointer to the next comparator. 0 = Reserved 1 = Ethernet comparator 2 2 = IP/UDP/ACH comparator 1 3 = IP/UDP/ACH comparator 2 4 = Reserved 5 = PTP/OAM comparator 6,7 = Reserved

**Table 31 • IP/ACH Next-Protocol Comparison**

Parameter	Width	Description
IP_Flow_Offset	5 bit	Indicates the starting position relative to the beginning of the IP frame header to start matching for the flow match/mask register pair. When used with IPv4 or 6, this will point to the first byte of the source address. When used with a protocol other than IPv4 or 6, this register points to the beginning of the field that will be used for flow matching.
IP_UDP_Checksum_Clear_Ena	1 bit	If set, the 2-byte UDP checksum should be cleared (written with zeros). This would only be used for UDP in IPv4.
IP_UDP_Checksum_Update_Ena	1 bit	If set, the last two bytes in the UDP frame must be updated to reflect changes in the PTP or OAM frame. This is necessary to preserve the validity of the IPv6 UDP checksum. Note that IP_UDP_Checksum_Clear_Ena & IP_UDP_Checksum_Update_Ena should never be set at the same time.
IP_UDP_Checksum_Offset	8 bit	This configuration field is only used if the protocol is IPv4. This register points to the location of the UDP checksum relative to the start of this header. This info is used later by the PTP/Y.1731 block to inform the rewriter of the location of the checksum in a UDP frame. This is normally right after the Log Message Interval field.
IP_UDP_Checksum_Width	2 bit	Specifies the length of the UDP checksum in bytes (normally 2 bytes)

The IP/ACH Comparator Flow Verification registers are used to verify the current frame against a particular flow within the engine. When this engine is used to verify IPv4 or IPv6 protocol, the flow is verified using either the source or destination address in the frame.

If the protocol is something other than IPv4 or IPv6, then the flow match can be used to match either a 32 or 128 bit field pointed to by the IP\_Flow\_Offset register. Mask bits can be used to shorten the length of the match, but there is no concept of source or destination address in this mode.

**Table 32 • IP/ACH Comparator Flow Verification Registers**

Parameter	Width	Description
IP_Flow_Ena	1 bit per flow	0 = Flow disabled 1 = Flow enabled
IP_Flow_Match_Mode	2 bit per flow	This register is only valid when the comparator block is configured to match on IPv4 or IPv6. It allows the match to be performed on the source address, destination address, or either address. 0 = Match on the source address 1 = Match on the destination address 2 = Match on either the source or the destination address
IP_Flow_Match	128 bit	Match bits for source & destination address in IPv4 & 6. Also used as the flow match for protocols other than IPv4 or 6. When used with IPv4, only the upper 32 bits are used and the remaining bits are not used.
IP_Flow_Mask	128 bit	Mask bits for IP_Flow_Match. For each bit, if it is a 1, the corresponding match bit is valid. If it is 0, the corresponding match bit is ignored.

**Table 32 • IP/ACH Comparator Flow Verification Registers**

Parameter	Width	Description
IP_Channel_Mask	1 bit per channel per flow	Enable for this match set for this channel
IP_Frame_Sig_Offset	5 bit	Points to the start of the field that will be used to build the frame signature. This register is only present in comparators where frame signature is supported. In other words, if there is no frame signature FIFO in a particular direction, this register will be removed.

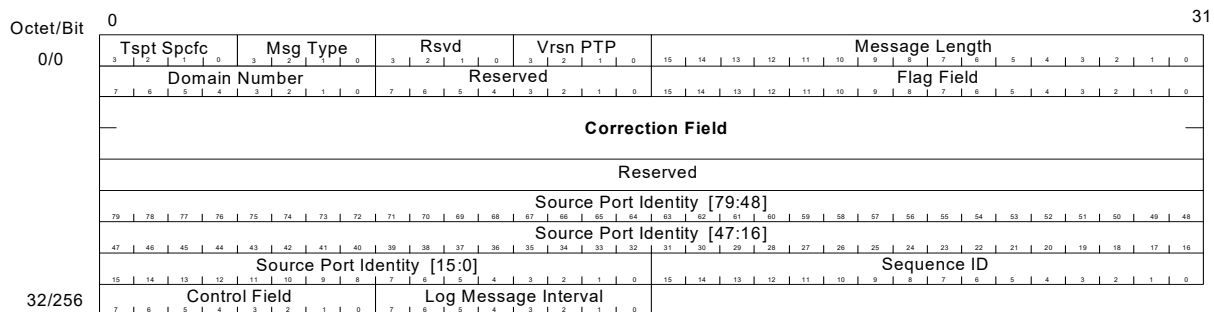
### 3.6.15.8 PTP/OAM Comparator

The PTP/OAM comparator is always the last stage in the analyzer for each encapsulation engine. It can validate IEEE 1588 PTP frames or OAM frames.

### 3.6.15.9 PTP Frame Header

The following illustration shows the header of a PTP frame.

**Figure 53 • PTP Frame Layout**

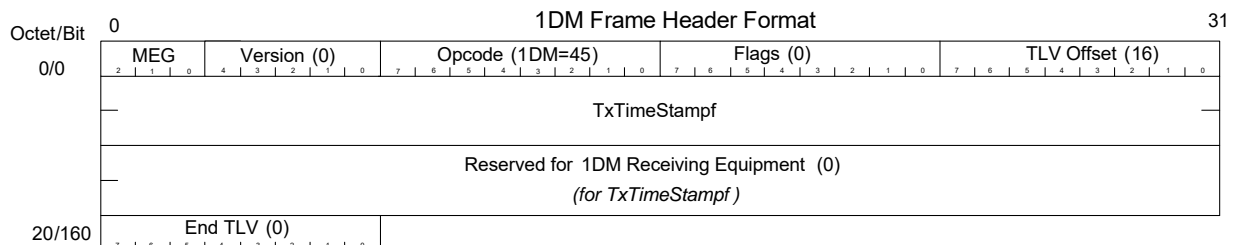


Unlike most of the other stages, there is no protocol validation for PTP frames; only interpretation of the header to determine what action to take. The first eight bytes of the header are used to determine the action to be taken. These match fields in the flow comparison registers with a corresponding set of command registers for each flow.

### 3.6.15.10 Y.1731 OAM Frame Header

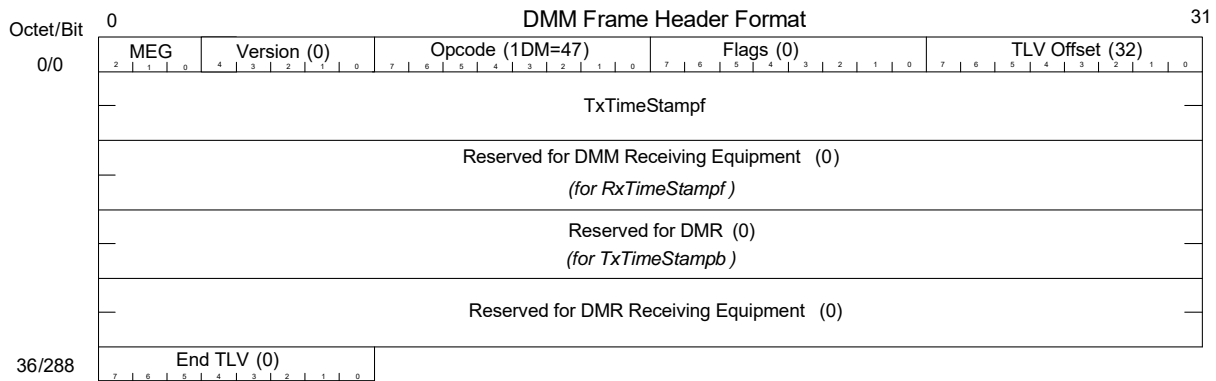
1DM, DMM, and DMR are the three supported Y.1731 frame headers. The following illustration shows the header part of a 1DM Y.1731 OAM frame.

**Figure 54 • OAM 1DM Frame Header Format**



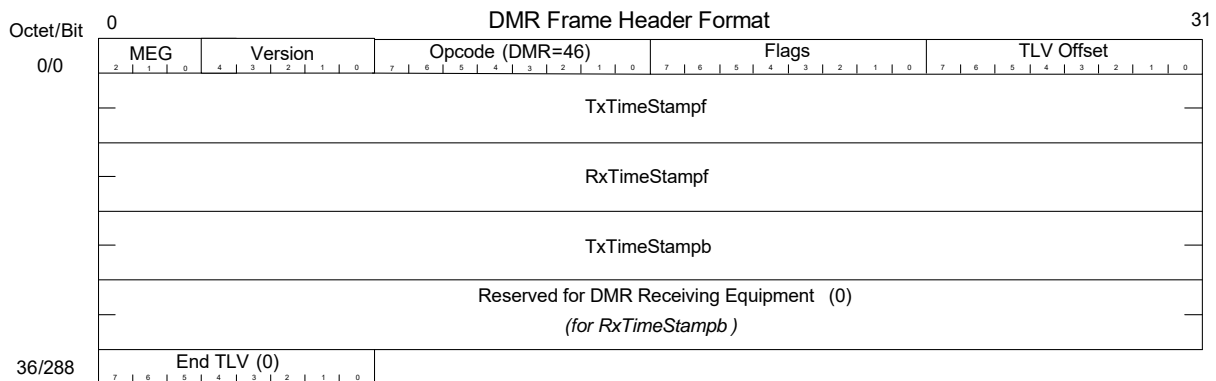
The following illustration shows a DMM frame header.

**Figure 55 • OAM DMM Frame Header Format**



The following illustration shows a DMR frame header.

**Figure 56 • OAM DMR Frame Header Format**



As with PTP, there is no protocol validation for Y.1731 frames; only interpretation of the header to determine what action to take. The first four bytes of the header are used to determine the action to be taken.

### 3.6.15.11 Y.1731 OAM PDU

1DM, DMM, and DMR are the three supported G.8113.1 PDUs and DMM/DMR are the two supported RFC6374 PDUs. The following illustrations show the PDU formats.

**Figure 57 • RFC6374 DMM/DMR OAM PDU Format**

	ETH (1)	14/18/22B
	MPLS labels (2)	4/8/12/16B
	ACH	4B
DMM/DMR OAM PDUs	OAM PDU Header	8B
	Time stamp 1	8B
	Time stamp 1	8B
	Time stamp 1	8B
	Time stamp 1	8B
	padding	(variable size)
	FCS	4B

(1) 0, 1, or 2 VLAN tags  
(2) Up to 4 MPLS labels

**Figure 58 • G8113.1/draft-bhh DMM/DMR/1DM OAM PDU Format**

DMM/DMR		1DM	
	ETH (1)	14/18/22B	14/18/22B
	MPLS labels (2)	4/8/12/16B	4/8/12/16B
	ACH	4B	4B
DMM/DMR OAM PDUs	OAM PDU Header	8B	8B
	Time stamp 1	8B	8B
	Time stamp 1	8B	8B
	Time stamp 1	8B	8B
	Time stamp 1	8B	8B
	End TLV indicator	1B	1B
	FCS	4B	4B

(1) 0, 1, or 2 VLAN tags  
(2) Up to 4 MPLS labels

As with PTP, there is no protocol validation for MPLS OAM; only interpretation of the header to determine what action to take. The first four bytes of the header are used to determine the action to be taken.

### 3.6.15.12 PTP Comparator Action Control Registers

The following registers perform matching on the frame header and define what action is to be taken based upon the match. There is one mask register for all flows, and the rest of the registers are unique for each flow.

**Table 33 • PTP Comparison**

Parameter	Width	Description
PTP_Flow_Match	64 bit	Matches bits in the PTP/Y.1731 frame starting at the beginning of the protocol header
PTP_Flow_Mask	64 bit	Mask bits for PTP_Flow_Match
PTP_Domain_Range_Lower	8 bit	Lower range of the domain field to match
PTP_Domain_Range_Upper	8 bit	Upper range of the domain field to match
PTP_Domain_Range_Enable	1 bit	Enable for range checking
PTP_Domain_Offset	5 bit	Pointer to the domain field, or whatever field is to be used for range checking

**Table 33 • PTP Comparison**

Parameter	Width	Description		
		Command Value	Mnemonic	Action
PTP_Action_Command	3 bit	0	NOP	Do nothing
		1	SUB	New correction field = Current correction field – Captured local time
		2	SUB_P2P	New correction field = Current correction field – Local latency + path_delay
		3	ADD	New correction field = Current correction field + Captured local time
		4	SUB_ADD	New correction field = Current correction field + (Captured local time + Local latency – Time storage field)
		5	WRITE_1588	Write captured local time to time storage field
		6	WRITE_P2P	Active_timestamp_ns = captured local time and path_delay written to time storage field and correction field (deprecated command)
		7	WRITE_NS	Write local time in nanoseconds to the new field
		8	WRITE_NS_P2P	Write local time in nanoseconds + p2p_delay to the new field and correction field
PTP_Save_Local_Time	1 bit	When set, saves the local time to the time stamp FIFO (only valid for egress ports).		
PTP_Correction_Field_Offset	5 bit	Points to the location of the correction field. Location is relative to the first byte of the PTP/OAM header.		
PTP_Time_Storage_Field_Offset	6 bit	Points to a location in a PTP frame where a time value can be stored or read.		
PTP_Add_Delay_Asymmetry_Enable	1 bit	When enabled, the value in the delay asymmetry register is added to the correction field of the frame.		
PTP_Subtract_Delay_Asymmetry_Enable	1 bit	When enabled, the value in the delay asymmetry register is subtracted from the correction field of the frame.		
PTP_Zero_Field_Offset	6 bit	Points to a location in the PTP/OAM frame to be zeroed if this function is enabled		
PTP_Zero_Field_Byte_Count	4 bit	The number of bytes to be zeroed. If this field is 0, then this function is not enabled.		

**Table 33 • PTP Comparison**

Parameter	Width	Description
PTP_Modified_Frame_Byte_Offset	3 bit	Indicates the position relative to the start of the PTP frame in bytes where the Modified_Frame_Status bit resides. This value is also used to calculate the offset from the beginning of the Ethernet packet to this field for use by the Rewriter.
PTP_Modified_Frame_Status_Update	1 bit	If set, tells the rewriter to update the value of this bit. Configuration registers inside the rewriter indicate if the bit will be set to 0 or 1.
PTP_Rewrite_Bytes	4 bits	Number of bytes in the PTP or OAM frame that must be modified by the Rewriter for the time stamp
PTP_Rewrite_Offset	8 bits	Points to where in the frame relative to the SFD that the time stamp should be updated
PTP_New_CF_Loc	8 bits	Location where the updated correction field value is written relative to the PTP header start
PTP_Channel_Mask	1 bit per channel per flow	Enable for this match set for this channel
PTP_Flow_Enable	1 bit	When set, the fields associated with this flow are all valid

The following table shows controls that are common to all flows.

**Table 34 • PTP Comparison: Common Controls**

Parameter	Width	Description
PTP_IP_CHKSUM_Sel	1 bit	0 = Use IP checksum controls from comparator 1 1 = Use IP checksum controls from comparator 2
FSB_Adr_Sel	2 bits	Selects the source of the address for use in the frame signature builder

The following table shows the one addition, per-flow, register.

**Table 35 • PTP Comparison: Additions for OAM-Optimized Engine**

Parameter	Width	Description
PTP_NXT_Prot_Group_Mask	2 bits	There are two bits for each flow. Each bit indicates if the flow can be associated with next-protocol group A or B. One or both bits may be set. If a bit is 1 for a particular next-protocol group, then a flow match is valid if the prior comparator stages also produced matches with the same next-protocol group.

### 3.6.15.13 Future Protocol Compatibility

Except for MPLS, the comparators are not hardwired to their intended protocols. They can be used as generic field and range comparators because all of the offsets or pointers to the beginning of the fields are configurable. The IP comparator is the most generic and would probably be the first choice for validating a new protocol.

Additionally, if there are not enough comparison resources in a single comparator block to handle a new protocol, two comparators back-to-back can be used by splitting up the comparison work. One portion can be validated in one comparator and then handed off to another. The only restriction is that there must be

at least one 64-bit word of separation between the start of the protocol and where the second starts to operate.

### 3.6.15.14 Reconfiguration

There are three ways to perform reconfiguration:

1. Disable an entire encapsulation engine.  
Once an engine has been disabled, any of the configuration registers associated with it may be modified in any order. If other encapsulation engines are still active, they will still operate normally.
2. Disable a flow in an active engine.  
Each stage in the engine has an enable bit for each flow. If a flow is disabled in a stage, its registers may be modified. Once reconfiguration for a flow in a stage is complete, it can be enabled.
3. Disable a comparator.  
Each comparator within the active encapsulation engine can be disabled. If an Ethernet header according to the configuration Type I or Type II with SNAP/LLC is not found then subsequent flows will not be matched. The ETH1 comparator can also be disabled so that all frames flowing through the IEEE 1588 block are time stamped.

The disabling of engines and flows is always done in a clean manner so that partial matches do not occur. Flows and engines are always enabled or disabled during inter-packet gaps or at the end of a packet. This guarantees that when a new packet is received that it will be analyzed cleanly.

If strict flow matching is enabled and a flow is disabled in one of the stages, then the entire flow is automatically disabled.

If any register in a stage that applies to all flows needs to be modified, then the entire encapsulation engine must be disabled.

### 3.6.15.15 Frame Signature Builder

Along with time stamp and CRC updates, the analyzer outputs a frame signature that can be stored in the time stamp FIFO to help match frames with other info in the FIFO. This information is used by the CPU so that it can match time stamps in the time stamp FIFO with actual frames. The frame signature is up to 16 bytes long and contains information from the Ethernet header (SA or DA), IP header (SA or DA), and from the PTP or OAM frame. The frame signature is only used in the egress direction.

The PTP block contains a set of mapping registers to configure which bytes are mapped into the frame signature. The following tables show the mapping for each byte.

**Table 36 • Frame Signature Byte Mapping**

Select	Source Byte
0-23	PTP header byte number = (31-select)
24	PTP header byte number 6
25	PTP header byte number 4
26	PTP header byte number 0
27	Reserved
28-35	Selected address byte (select-28)

**Table 37 • Frame Signature Address Source**

Parameter	Width	Description
FSB_Map_Reg_0-15	6 bits	For each byte of the frame signature, use <a href="#">Table 36</a> , page 87 to select which available byte is used. Frame signature byte 0 is the LSB. If not all 16 bytes are needed, the frame signature should be packed towards the LSB and the upper unused byte configuration values do not need to be programmed.



**Table 37 • Frame Signature Address Source**

Parameter	Width	Description
FSB_Adr_Sel	2 bits	Selects the source of the address for use in the frame signature builder according to the following list
	<b>Select Value</b>	<b>Address Source</b>
	0	Ethernet block 1
	1	Ethernet block 2
	2	IP block 1
	3	IP block 2

Configuration registers in each comparator block supply an address to select if it is the source address or the destination address.

A frame signature can be extracted from frames matching in all the three engines. The frame signature address selection is limited to Ethernet Block1 because only a limited number of encapsulations are supported in the third engine, Engine C.

Engine C has two parts: part A and part B. Part A supports ETH1, ETH2, MPLS protocols while part B supports only ETH1 protocol. Selection of Ethernet block 1 or 2 is dependent on whether part A flow matches or part B flow matches.

If a frame matches part A flow configuration, then the frame signature as configured in ETH1\_NXT\_PROTOCOL\_A and ETH2\_NXT\_PROTOCOL\_A using FSB\_ADR\_SEL will be considered in computing the frame signature.

If a frame matches part B flow configuration, then the frame signature as configured in ETH1\_NXT\_PROTOCOL\_A and FSB\_ADR\_SEL will be considered in computing the frame signature. In this configuration if FSB\_ADR\_SEL is set to 1, to select ETH2 then all zeros are padded as frame signature because ETH2 is not supported by part B.

### 3.6.15.16 Configuration Sharing

The analyzer configuration services both channels. Each flow within each comparator has a channel-mask register that indicates which channels the flow is valid for. Each flow can be valid for channel A, channel B, or both channels.

A total of eight flows can be allocated the two channels if the analyzer configuration cannot be shared. They can each have four distinct flows (or three for the one, and five for the other, etc.).

### 3.6.15.17 OAM-Optimized Engine

The OAM optimized engine, Engine C, supports a fewer set of encapsulations such as ETH1, ETH2, MPLS, and ACH. Engine C is enhanced with an ACH comparator to support the MPLS-TP OAM protocol. The MPLS-TP OAM protocol for Engine C is configured in the following registers.

- EGR2\_ACH\_PROT\_MATCH\_UPPER/LOWER\_A
- EGR2\_ACH\_PROT\_MASK\_UPPER/LOWER\_A
- EGR2\_ACH\_PROT\_OFFSET\_A

The ACH comparator will start the comparison operation right after the MPLS comparator.

In addition to the descriptions of the Ethernet and MPLS blocks in the OAM optimized engine, there is the notion of protocol-A/protocol-B. When a match occurs in the Ethernet 1 block the status of the protocol set that produced the match is indicated. There are two bits, one for protocol A and another for protocol B. If both sets produce a match, then both bits are set.

These bits are then carried to the next comparison block and only allow flow matches for the protocol sets that produced matches in the prior block. This block also produces a set of protocol match bits that are also carried forward.

This feature is provided to prevent a match with protocol set A in the first block and protocol set B in the second block.

### 3.6.16 Time Stamp Processor

The primary function of the time stamp processor block is to generate a new `Timestamp_field` or new `Correction_field` (Transparent clocks) for the rewriter block. The time stamp block generates an output that is either a snapshot of the corrected Local Time (struct time stamp) or a signed (two's complement) 64 bit `Correction_field`.

In the ingress direction, the time stamp block calculates a new time stamp for the rewriter that indicates the earlier time when the corresponding PTP event frame entered the chip (crossed the reference plane referred to in the IEEE 1588 standard).

In the egress direction, the time stamp block calculates a new time stamp for the rewriter in time for the PCS block to transmit the new time stamp field in the frame. In this case the time stamp field indicates when the corresponding PTP event frame will exit the chip.

Transparent clocks correct PTP event messages for the time resided in the transparent clock. Peer-to-Peer transparent clocks additionally correct for the propagation time on the inbound link (`Path_delay`). The `Path_delay [ns]` input to the time stamp block is software programmed based upon IEEE 1588 path delay measurements.

In general, the IEEE 1588 standard allows for a transparent clock to update the `Correction_Field` for both PTP event messages as well as the associated follow up message (for two-step operation). However, the TSP only updates PTP event messages. Also, the 1588 standard allows that end-to-end transparent clocks correct and forward all PTP-timing messages while Peer-to-Peer transparent clocks only correct and forward Sync and Follow\_Up messages. Again, the TSP only updates PTP event messages (not Follow\_Up messages).

Internally, the time stamp block generates an `Active_timestamp` from the captured/time stamped Local time (`Raw_timestamp`). The `Active_time` stamp is the `Raw_timestamp` corrected for the both fixed (programmed) local chip, and variable chip latencies relative to where the `Start_of_Frame_Indicator` captures the local time. The time stamp block operates on the `Active_timestamp` based on the Command code.

The `Active_timestamp` is calculated differently in the Ingress and Egress directions and the equations are given below.

In the ingress direction:

$$\text{Active\_timestamp} = \text{Raw\_timestamp} - \text{Local\_latency} - \text{Variable\_latency}$$

In the egress direction:

$$\text{Active\_timestamp} = \text{Raw\_timestamp} + \text{Local\_latency} + \text{Variable\_latency}$$

In addition, the following values are also calculated for use by the commands:

$$\text{Active\_timestamp\_ns} = \text{Active\_timestamp converted to nanoseconds}$$

$$\text{Active\_timestamp\_p2p\_ns} = \text{active\_timestamp\_ns} + \text{path delay}$$

The `Local_latency` is a programmed fixed value while the `Variable_latency` is predicted from the PCS logic based upon the current state of the ingress or egress data pipeline.

For the option of Peer-to-Peer transparent clocks, the ingress `Active_timestamp` calculation includes an additional `Path_delay` component. The path delay is always added for a transparent clock per the standard. The path delay is always added to the correction field.

The signed 32-bit two's complement Delay Asymmetry register (bits 31–0) can be programmed by the user. Bit 31 is the sign bit. Bits 15–0 are scaled nanoseconds just like for the `CorrectionField` format. The `DelayAsymmetry` register (whether it be positive or negative) will be sign extended and added to the 64-bit correction field (signed add) if the `Add_Delay_Asymmetry` bit is set. The `DelayAsymmetry` register (whether it be positive or negative) will be sign extended and subtracted from the 64-bit correction field (signed Subtract) if the `Subtract_Delay_Asymmetry` bit is set.

The time stamp block keeps a shadow copy of the programmed latency values (`Local_latency`, `Path_delay`, and `Delay_Asymmetry`) to protect against CPU updates.

### 3.6.17 Time Stamp FIFO

The time stamp FIFO stores time stamps along with frame signature information. This information can be read out by a CPU or pushed out on a dedicated Serial Time Stamp Output Interface and used in 2-step processing mode to create follow-up messages. The time stamp FIFO is only present in the egress data path.

#### 3.6.17.1 Time Stamp FIFO CPU Access

The time stamp FIFO takes a frame signature from the analyzer and the updated correction field, and the full data set for that time stamp is saved to the FIFO. This creates an interrupt to the CPU. If the FIFO ever overflows this is indicated with an interrupt.

The stored frame signature can be of varying sizes controlled by the `EGR_TSFIFO_CSR.EGR_TS_SIGNAT_BYTES` register. Only the indicated number of signature bytes is saved with each time stamp. The saved values are packed so that reducing the number of signature bytes allows more time stamps to be saved.

The packing of the time stamp data is done by logic before the write occurs to the FIFO. When no compression is used, each time stamp may contain 208 bits of information consisting of 128 bits of frame signature and 80 bits of time stamp data. Therefore a full sized time stamp is 26 bytes long. Compressing the frame signature can reduce this to as little as 10 bytes (or 4 bytes if `EGR_TSFIFO_CSR.EGR_TS_4BYTES = 1`) if no signature information is saved (`EGR_TSFIFO_CSR.EGR_TS_SIGNAT_BYTES = 0`). The value to store is built up in an internal register. When the register contains 26 valid bytes, that data is written to the time stamp FIFO. Data in the FIFO is packed end-to-end. It is up to the reader of the data to unpack the data.

The time stamps in the FIFO are visible and accessible for the CPU as a set of 32-bit registers. Multiple register reads are required to read a full time stamp if all bits are used. Bit 31 in register `EGR_TSFIFO_0` contains the current FIFO empty flag, which can be used by the CPU to determine if the current time stamps are available for reading. If the bit is set, the FIFO is empty and no time stamps are available. The value that was read can be discarded because it does not contain any valid time stamp data. If the bit is 0 (deasserted), the value contains 16 valid data bits of a time stamp. The remaining bits should be read from the other registers in the other locations and properly unpacked to recreate the time stamp. Care should be taken to read the time stamps one at a time as each read of the last (7th) address will trigger a pop of the FIFO.

Time stamps are packed into seven registers named `EGR_TSFIFO_0` to `EGR_TSFIFO_6`. If the time stamp FIFO registers are read to the point that the FIFO goes empty and there are remaining valid bytes in the internal packing register, then the packing register is written to the FIFO. In this case the registers may not be fully packed with time stamps. Flag bits are used to indicate where the valid data ends within the set of seven registers. The flag bits are in register `EGR_TSFIFO_0.EGR_TS_FLAGS` (together with the empty flag) and are encoded as follows:

- 000 = Only a partial time stamp is valid in the seven register set
- 001 = One time stamp begins in the current seven register set
- 010 = Two time stamps begin in the current seven register set.
- 011 = Three time stamps begin in the current seven register set (4-byte mode)
- 100 = Four time stamps begin in the current seven register set (4-byte mode)
- 101 = Five time stamps begin in the current seven register set (4-byte mode)
- 110 = Six time stamps begin in the current seven register set (4-byte mode)
- 111 = The current seven register set is fully packed with valid time stamp data

The FIFO empty bit is visible in the `EGR_TSFIFO_0.EGR_TS_EMPTY` register so the CPU can poll this bit to know when time stamps are available. There is also a maskable interrupt which will assert whenever the time stamp FIFO level reaches the threshold given in `EGR_TSFIFO_CSR.EGR_TS_THRESH` register. The FIFO level is also visible in the `EGR_TSFIFO_CSR.EGR_TS_LEVEL` register. If the time stamp FIFO overflows, writes to the FIFO are inhibited. The data in the FIFO is still available for reading but new time stamps are dropped.

**Note:** Time stamp FIFO exists only in the Egress direction. There is no time stamp FIFO in the Ingress direction

### 3.6.17.2 Serial Time Stamp Output Interface

For each 1588 Processor 0 and 1, time stamp information stored in the Egress direction can be read through either the register interface or through the Serial Time Stamp interface. These two ways to read registers are mutually exclusive. While enabling/disabling the serial interface is done on a Processor level, only one serial interface exists. This means the serial interface can be enabled for Processor 0, while the time stamp FIFO can be read through registers for Processor 1. If the serial interface is enabled for both Processor 0 and 1, then the serial interface will arbitrate between two Egress time stamp FIFOs in Processor 0 and 1 and push the data out.

The time stamp FIFO serial interface block writes, or pushes, time stamp/frame signature pairs that have been enqueued and packed into time stamp FIFOs to the external chip interface consisting of three output pins: 1588\_SPI\_DO, 1588\_SPI\_CLK, and 1588\_SPI\_CS. There is one interface for all channels.

When the serial interface (SPI) is enabled, the time stamp/frame signature pairs are dequeued from time stamp FIFOs and unpacked. Unpacked time stamp/frame signature pairs are then serialized and sent one at a time to the external interface. Unpacking shifts the time stamp/frame signature into alignment considering the configured size of the time stamps and frame signatures (a single SI write may require multiple reads from a time stamp FIFO). The time stamp FIFO serial interface is an alternative to the CPU register interface described in the time stamp FIFO section. When the serial time stamp interface is enabled in register TS\_FIFO\_SI\_CFG.TS\_FIFO\_SI\_ENA, data read from the time stamp FIFO registers described in [Time Stamp FIFO](#), page 90 are invalid.

Time stamp/Frame signature pairs from two egress time stamp FIFOs are serialized one at a time and transmitted to the interface pins. The TS\_FIFO\_SI arbitrates in a round-robin fashion between the ports that have non-empty time stamp FIFOs. The port associated with each transmitted time stamp/frame signature pair is indicated in a serial address that precedes the data phase of the serial transmission. Because the time stamp FIFOs are instantiated in the per port clock domains, a small single entry asynchronous SI FIFO (per port) ensures that the time stamp/frame signature pairs are synchronized, staged, and ready for serial transmission. When an SI FIFO is empty, the SI FIFO control fetches and/or unpacks a single time stamp/frame signature performing any time stamp FIFO dequeues necessary. The SI FIFO goes empty following the completion of the last data bit of the serial transmission. Enabled ports (TS\_FIFO\_SI\_CFG.TS\_FIFO\_SI\_ENA) participate in the round-robin selection.

Register TS\_FIFO\_SI\_TX\_CNT accumulates the number of time stamp/frame signature pairs transmitted from the serial time stamp interface for each channel. Register EGR\_TS\_FIFO\_DROP\_CNT accumulates the number of time stamp/frame signature pairs that have been dropped per channel due to a time stamp FIFO overflow.

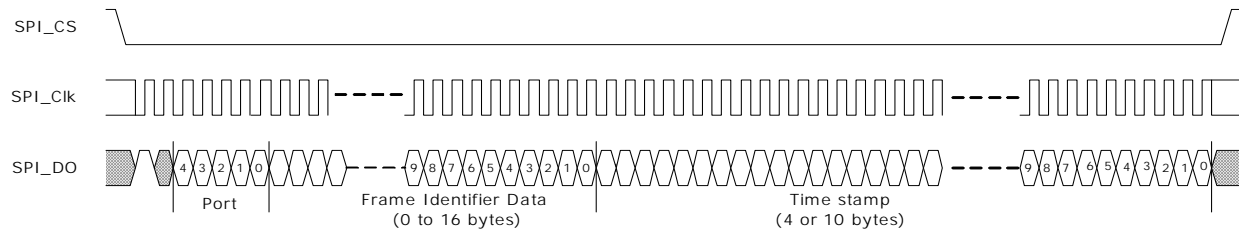
The SPI compatible interface asserts a chip select (SPI\_CS) for each write followed by a write command data bit equal to 1, followed by a "don't care" bit (0), followed by an address phase, followed by a data phase, followed by a deselect where SPI\_CS is negated. Each write command corresponds to a single time stamp/frame signature pair. The length of the data phase depends upon the sum of the configured lengths of the time stamp and signature, respectively. The address phase is fixed at five bits. The SPI\_CLK is toggled to transfer each SPI\_DO bit (as well as the command and address bits). The Time Stamp and Frame Identifier Data from the following illustration are sent MSB first down to LSB (bit 0) in the same format as stored in the seven registers of TS FIFO CSRs. For more information, see [Time Stamp FIFO](#), page 90 and [Figure 59](#), page 92.

The frequency of the generated output 1588\_SPI\_CLK can be flexibly programmed from 10 MHz up to 62.5 MHz using TS\_FIFO\_SI\_CFG to set the number of CSR clocks that the 1588\_SPI\_CLK is both high and low. For example, to generate a 1588\_SPI\_CLK that is a divide-by-6 of the CSR clock, the CSR register would be set such that both SI\_CLK\_LO\_CYCS and SI\_CLK\_HI\_CYCS equal 3. Also, the number of CSR clocks after SPI\_CS asserts before the first 1588\_SPI\_CLK is programmable (SI\_EN\_ON\_CYCS), as is the number of clocks before SI\_CS negates after the last 1588\_SPI\_CLK (SI\_EN\_OFF\_CYCS). The number of clocks during which SI\_CS is negated between writes is also programmable (SI\_EN\_DES\_CYCS). The 1588\_SPI\_CLK may also be configured to be inverted (SI\_CLK\_POL).

Without considering de-selection between writes, if the PTP 16-byte SequenceID (frame signature) is used as frame identifier each 10 byte time stamp write take  $2 + 55 + 10 \times 8 + 16 \times 8 = 265$  clocks (at

40 MHz) ~6625 ns. This corresponds to a time stamp bandwidth of > 0.15 M time stamp/second/port. The following illustration shows the serial time stamp/frame signature output.

**Figure 59 • Serial Time Stamp/Frame Signature Output**



### 3.6.18 Rewriter

When the rewriter block gets a valid indication it overwrites the input data starting at the offset specified in Rewrite\_offset and replaces N bytes of the input data with updated N bytes. Frames are modified by the rewriter as indicated by the analyzer-only PTP/OAM frames are modified by the rewriter.

The output of the rewriter block is the frame data stream that includes both unmodified frames and modified PTP frames. The block also outputs a count of the number of modified PTP frames in INGR\_RW\_MODFRM\_CNT/EGR\_RW\_MODFRM\_CNT, depending upon the direction. This counter accumulates the number of PTP frames to which a write was performed and includes errored frames.

#### 3.6.18.1 Rewriter Ethernet FCS Calculation

The rewriter block has to recalculate the Ethernet CRC for the PTP message to modify the contents by writing a new time stamp or clear bytes. Two versions of the Ethernet CRC are calculated in accordance with IEEE 802.3 Clause 3.2.9: one on the unmodified input data stream and one on the modified output data stream. The input frame FCS is checked against the input calculated FCS and if the values match, the frame is good. If they do not, then the frame is considered a bad or errored frame. The new calculated output FCS is used to update the FCS value in the output data frame. If the frame was good, then the FCS is used directly. If the frame was bad, the calculated output FCS is inverted before writing to the frame. Each version of the FCS is calculated in parallel by a separate FCS engine.

A count of the number of PTP/OAM frames that are in error is kept in the INGR\_RW\_FCS\_ERR\_CNT or EGR\_RW\_FCS\_ERR\_CNT register, depending upon the direction.

#### 3.6.18.2 Rewriter UDP Checksum Calculation

For IPv6/UDP, the rewriter also calculates the value to write into the dummy blocks to correct the UDP checksum. The checksum correction is calculated by taking the original frame's checksum, the value in the dummy bytes, and the new data to be written; and using them to modify the existing value in the dummy byte location. The new dummy byte value is then written to the frame to ensure a valid checksum. The location of the dummy bytes is given by the analyzer. The UDP checksum correction is only performed when enabled using the following register bits:

- INGR\_IP1\_UDP\_CHKSUM\_UPDATE\_ENA
- INGR\_IP2\_UDP\_CHKSUM\_UPDATE\_ENA
- EGR\_IP1\_UDP\_CHKSUM\_UPDATE\_ENA
- EGR\_IP2\_UDP\_CHKSUM\_UPDATE\_ENA

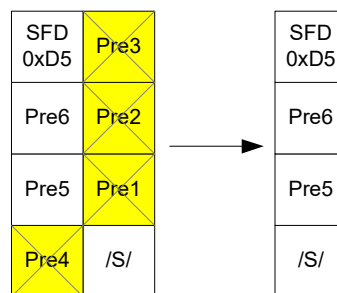
Based upon the analyzer command and the rewriter configuration, the rewriter writes the time stamp in one of the following ways:

- Using PTP\_REWRITE\_BYTES to choose four bytes write to PTP\_REWRITE\_OFFSET. This method is similar to other PTP frame modifications and the time stamp is typically written to the reserved field in the PTP header.
- Using PTP\_REWRITE\_BYTES and RW\_REDUCE\_PREAMBLE to select the mode of operation when writing Rx time stamps into the frame. In these modes, it cannot do both a time stamp write/append and a PTP operation in the same frame. If PTP\_REWRITE\_BYTES = 0xE and RW\_REDUCE\_PREAMBLE = 1, it does it by overwriting the existing FCS with the time stamp in the lowest four bytes of the calculated time stamp and generating a new FCS and appending it.

Because the rewriter cannot modify the IFG or change the size of the frame, if the original FCS is overwritten with time stamp data a new FCS needs to be appended and the frame shortened by reducing the preamble. The preamble length includes the /S/ character and all preamble characters up to but not including the SFD. In this mode, it is assumed that all incoming preambles are of sufficient (5 to 7-byte) length to delete four bytes and the preamble of every frame (not only PTP frames) will be reduced by four bytes by deleting four bytes of the preamble. Then, the new FCS is written at the end of the matched frame. For unmatched frames, or if the PTP\_REWRITE\_BYTES is anything but 0xE, the IFG is increased by adding four IDLE (/I/) characters after the /T/ which ends the packet.

To time stamp a frame in one of the modes, the actual length of the preamble is then checked and if the preamble is too short to allow a deletion of four bytes (if the preamble is not five bytes or more) then no operations are performed on the preamble, the FCS is not overwritten, and no time stamp is appended. For all such frames, a counter is maintained and every time an unsuccessful operation is encountered, the counter is incremented. This counter is read through register: INGR\_RW\_PREAMBLE\_ERR\_CNT/EGR\_RW\_PREAMBLE\_ERR\_CNT. The following illustration shows the deleted preamble bytes.

**Figure 60 • Preamble Reduction in Rewriter**



If PTP\_REWRITE\_BYTES = 0xF and RW\_REDUCE\_PREAMBLE = 0, the rewriter replaces the FCS of the frame with the four lowest bytes of the calculated time stamp and does not write the FCS to the frame. In this mode, all the frames have corrupted FCSs and the MAC needs to be configured to handle this case. In the case of a CRC error in the original frame, the rewriter writes all ones (0xFFFFFFFF) to the FCS instead of the time stamp. This indicates an invalid CRC to the MAC because this is reserved to indicate an invalid time stamp. In the rare case that the actual time stamp has the value 0xFFFFFFFF and the CRC is valid, the rewriter increments the time stamp to 0x0 and writes that value instead. This causes an error of 1 ns but is required to reserve the time stamp value of 0xFFFFFFFF for frames with an invalid CRC.

A flag bit may also be set in the PTP message header to indicate that the TSU has modified the frame (when set) or to clear the bit (on egress). The analyzer sends the byte offset of the flag byte to the rewriter in PTP\_MOD\_FRAME\_BYTE\_OFFSET and indicates whether the bit should be modified or not using PTP\_MOD\_FRAME\_STATUS\_UPDATE. The bit offset within the byte is programmed in the configuration register RW\_FLAG\_BIT. When the PTP frame is being modified, the selected bit is set to the value in the RW\_FLAG\_VAL. This only occurs when the frame is being modified by the rewriter; when the PTP frame matches and the command is not NOP.

### 3.6.19 Local Time Counter

The local time counter keeps the local time for the device and the time is monitored and synchronized to an external reference by the CPU. The source clock for the counter is selected externally to be a 250 MHz, 200 MHz, 125 MHz, or some other frequency. The clock may be a line clock or the dedicated CLK1588P/N pins. The clock source is selected in register LTC\_CTRL.LTC\_CLK\_SEL.

To support other frequencies, a flexible counter system is used that can convert almost any frequency in the 125–250 MHz range into a usable source clock. Supported frequencies of local time counter are 125 MHz, 156.25 MHz, 200 MHz, and 250 MHz. The frequency is programmed in terms of the clock period. Set the LTC\_SEQUENCE.LTC\_SEQUENCE\_A register to the clock period to the nearest whole number of nanoseconds to be added to the local time counter on each clock cycle. Set LTC\_SEQ.LTC\_SEQ\_E to the amount of error between the actual clock period and the LTC\_SEQUENCE.LTC\_SEQUENCE\_A setting in femtoseconds. Register LTC\_SEQ.LTC\_SEQ\_ADD\_SUB indicates the direction of the error.

An internal counter keeps track of the accumulated error. When the accumulated error exceeds 1 nanosecond, an extra nanosecond is either added or subtracted from the local time counter. Use the following as an example to program a 5.9 ns period:

```
LTC_SEQUENCE.LTC_SEQUENCE_A = 6 (6 ns)
LTC_SEQ.LTC_SEQ_E = 100000 (0.1 ns)
LTC_SEQ.LTC_SEQ_ADD_SUB = 0 (subtract an extra nanosecond, i.e add 5 ns)
```

To support automatic PPM adjustments, an internal counter runs on the same clock as the local time counter, and increments using the same sequence to count nanoseconds. The maximum (rollover) value of the internal counter in nanoseconds is given in register LTC\_AUTO\_ADJUST.LTC\_AUTO\_ADJUST\_NS. At rollover, the next increment of the local time counter is increased by one additional or one less nanosecond as determined by the LTC\_AUTO\_ADJUST.LTC\_AUTO\_ADD\_SUB\_1NS register. When LTC\_AUTO\_ADJUST.LTC\_AUTO\_ADD\_SUB\_1NS is set to 0x1, an additional nanosecond is added to the local time counter. When it is set to 0x2, one less nanosecond is added to the local timer counter. No PPM adjustments are made when the register is set to 0x0 or 0x3.

PPM adjustments to the local time counter can be made on an as-needed basis by writing to the one-shot LTC\_CTRL.LTC\_ADD\_SUB\_1NS\_REQ register. One nanosecond is added or subtracted from the local time counter each time LTC\_CTRL.LTC\_ADD\_SUB\_1NS\_REQ is asserted. The LTC\_CTRL.LTC\_ADD\_SUB\_1NS register setting controls whether the local time counter adjustment is an addition or a subtraction.

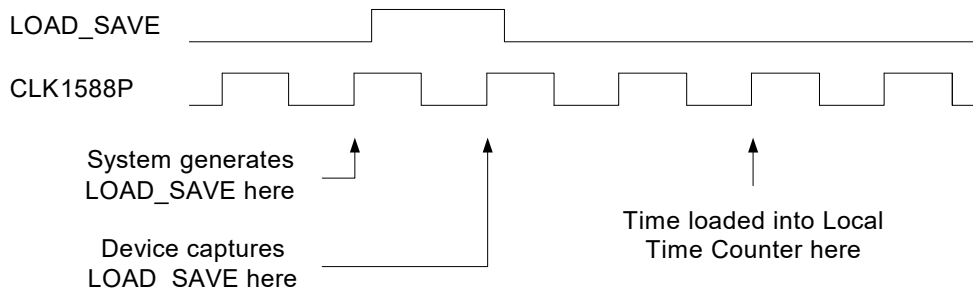
The current time is loaded into the local time counter with the following procedure.

1. Configure the 1588\_LOAD\_SAVE pin.
2. Write the time to be loaded into the local time counter in registers LTC\_LOAD\_SEC\_H, LTC\_LOAD\_SEC\_L and LTC\_LOAD\_NS.
3. Program LTC\_CTRL.LTC\_LOAD\_ENA to a 1.
4. Drive the 1588\_LOAD\_SAVE pin from low to high.

The time in registers LTC\_LOAD\_SEC\_H, LTC\_LOAD\_SEC\_L and LTC\_LOAD\_NS is loaded into the local time counter when the rising edge of the 1588\_LOAD\_SAVE strobe is detected. The LOAD\_SAVE strobe is synchronized to the local time counter clock domain.

When the 1588\_DIFF\_INPUT\_CLK\_P/N pins are the clock source for the local time counter, and the LOAD\_SAVE strobe is synchronous to 1588\_DIFF\_INPUT\_CLK\_P/N, the LTC\_LOAD\* registers are loaded into the local time counter, as shown in the following illustration.

**Figure 61 • Local Time Counter Load/Save Timing**



When the LOAD\_SAVE strobe is not synchronous to the 1588\_DIFF\_INPUT\_CLK\_P/N pins or an internal clock drives the local time counter, there is some uncertainty as to when the local time counter is loaded, when higher accuracy circuit is turned off. This reduces the accuracy of the time stamping function by the period of the local time counter clock. When higher accuracy circuit is ON, any difference between the 1588\_DIFF\_INPUT\_CLK\_P and the rising edge of 1588\_LOAD\_SAVE is compensated within an error of 1 ns. This applies to both load and save operations.

**Note:** There is a local time counter in each channel. The counter is initialized in both channels if the LTC\_CTRL.LTC\_LOAD\_ENA register in each channel is asserted when the LOAD\_SAVE strobe occurs.

When LTC\_CTRL.LTC\_SAVE\_ENA register is asserted when the 1588\_LOAD\_SAVE input transitions from low to high, the state of the local time counter is stored in the LTC\_SAVED\_SEC\_H, LTC\_SAVED\_SEC\_L, and LTC\_SAVED\_NS registers.

The current local time can be stored in registers with the following procedure.

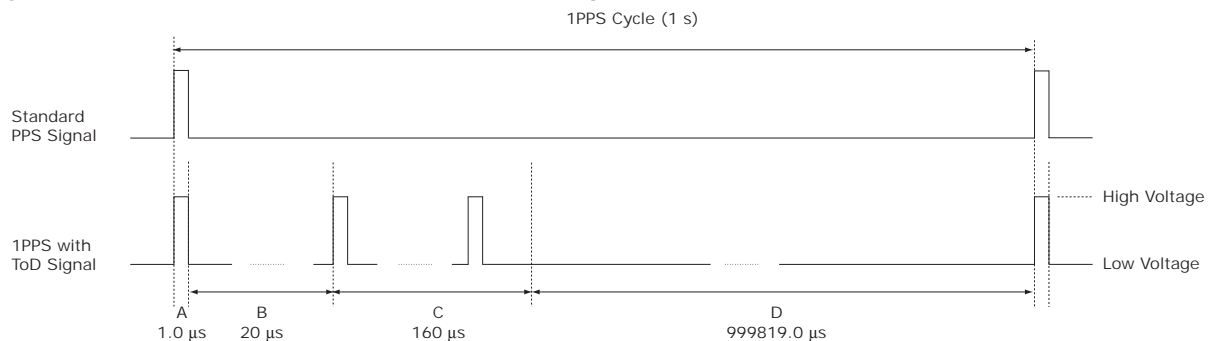
1. Configure the 1588\_LOAD\_SAVE pin.
2. Program LTC\_CTRL.LTC\_SAVE\_ENA to a 1.
3. Set SER\_TOD\_INTF.LOAD\_SAVE\_AUTO\_CLR to 1 if the operation is one-time save operation. This will clear LTC\_CTRL.LTC\_SAVE\_ENA after the operation.
4. Drive the 1588\_LOAD\_SAVE pin from low to high.
5. Read the value from LTC\_SAVED\_SEC\_H, LTC\_SAVED\_SEC\_L, and LTC\_SAVED\_NS registers.

As with loading the local time counter, there is one clock cycle of uncertainty as to when the time is saved if the LOAD\_SAVE strobe is not synchronous to the clock driving the counter.

### 3.6.20 Serial Time of Day

In addition to loading or saving as described in the preceding sections, it is possible to load or save LTC time in a serial fashion. For serial load, 1588\_LOAD\_SAVE has to send Time of Day (ToD) information in a specific format. For serial save, when the appropriate register bits is set, then PPS will drive out the ToD information. The following illustration shows the format for serial load and save.

**Figure 62 • Standard PPS and 1PPS with TOD Timing Relationship**



#### 3.6.20.1 Pulse per Second Segment

In the preceding illustration, segment A is the pulse per second segment. The PPS signal is transmitted with high voltage. The rising edge of the PPS signal is aligned with the rising edge of the standard PPS signal. This segment lasts 1 μs. To obtain high accuracy, the response delay of the rising edge of the PPS signal should be considered.

#### 3.6.20.2 Waiting Segment

In the preceding illustration, segment B is the Waiting segment. Due to the speed of operation, this segment is needed to make it easier for the receiver to obtain the following Time-of-Day information in current PPS cycle. The signal is in low voltage during this segment, which lasts 20 μs.

#### 3.6.20.3 Time-of-Day Segment

In the preceding illustration, segment C is the Time-of-Day segment. The ToD information being carried in this segment indicates the time instant of the rising edge of the PPS signal transmitted in segment A of the current PPS cycle. The time instant is measured using the original network clock. In this segment, the ToD information is continuously transported and is represented in 16 octets. It consists of the following fields:

- Second field: 6 octets. It represents the time instant of the rising edge of the PPS signal in second. The value is defined as in IEEE 1588-2008.
- Date field: 6 octets. It represents the time instant of the rising edge of the PPS signal in year, month, day, hour, minute, and second. Each part is represented by one octet (the format of this field is 0xYYMMDDHHMMSS). In particular, only the lowest 2 decimal digits of the year are represented. The receiver can easily obtain the time instant of the rising edge of the PPS signal in this transparent format without additional circuitry to translate the value of the second field. It also has the significant

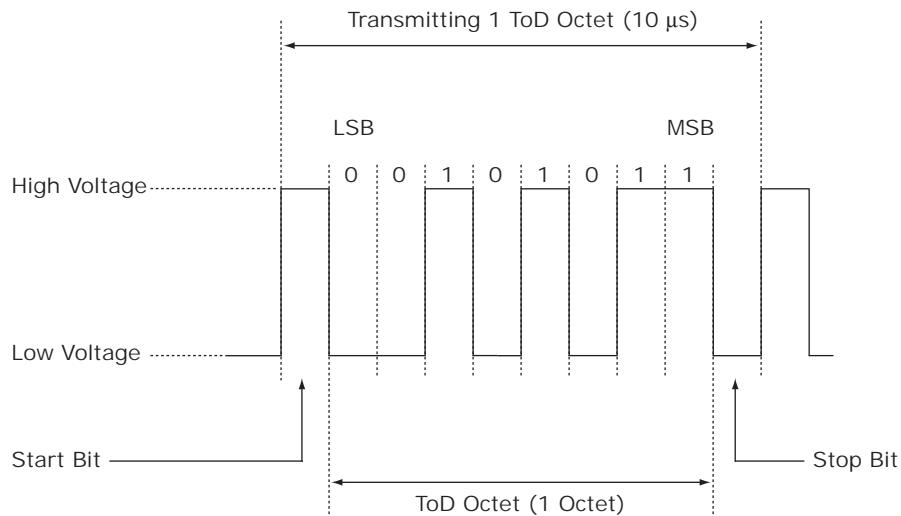


benefit of changing the value of this field when leap year or leap second occurs. (The Date field is ignored at the serial ToD input and is not generated at the serial ToD output.)

- Reserved field: 4 octets. Reserved for future use.

The ToD information is represented in units of octet, with each octet being transmitted with the low-order bit first. The following illustration shows an octet is transmitted between a start bit with high voltage and a stop bit with low voltage. The other octets are transmitted in the same manner. As a result,  $(1+8+1) \times 1 \mu\text{s} = 10 \mu\text{s}$  are needed to transport one octet. This segment lasts  $16 \times 10 \mu\text{s} = 160 \mu\text{s}$  to convey the ToD information.

**Figure 63 • ToD Octet Waveform**



The entire Time-of-Day segment should be detected. If the second 6 octets representing the Date field are not used by the upper layer, the Date field should still be detected and its value can be ignored.

### 3.6.20.4 Idle Segment

Segment D is the Idle segment in Figure 62, page 95. It follows segment C with high voltage until the end of the PPS cycle. The duration of the Idle segment is given by the following calculation.

$$1 \text{ s} - 0.5 \mu\text{s} - 20 \mu\text{s} - 160 \mu\text{s} = 999819.5 \mu\text{s}.$$

Use the following steps to enable Serial load.

1. Set SER\_TOD\_INTF.SER\_TOD\_INPUT\_EN to 1
2. Set LTC\_CTRL.LOAD\_EN to 1.
3. Start the transmission of 1588\_LOAD\_SAVE conforming to the format.
4. To check the data transmission, enable serial save or save LTC time to check the registers.
5. To enable serial save, set SER\_TOD\_INTF.SER\_TOD\_OUTPUT\_EN to 1.

The following table lists the different options to load or save LTC time.

**Table 38 • LTC Time Load/Save Options**

LTC_CTRL.LOAD_EN	SER_TOD_INTF.SER_TOD_INPUT_EN	LTC_CTR.SAVE_EN	Expected Operation
0	0	1	Parallel Save
0	1	1	Save
0	0	0	No operation
0	1	0	No operation
1	0	0	Parallel Load
1	1	0	Serial Load
1	0	1	Parallel Load and Save

**Table 38 • LTC Time Load/Save Options (continued)**

LTC_CTRL.LOAD_EN	SER_TOD_INTF.SER_TOD_INPUT_EN	LTC_CTR.SAVE_EN	Expected Operation
1	1	1	Serial Load and Save

When SER\_TOD\_INTF.SERIAL\_ToD\_OUTPUT\_EN is set the PPS output is driven with a serial ToD output based on the LTC timer value.

### 3.6.21 Programmable Offset for LTC Load Register

When a new LTC value is loaded into the system, a fixed offset may need to be added to the loaded value. Program SER\_TOD\_INTF.LOAD\_PULSE\_DLY and this value will be added to LTC counter whenever a new load occurs either through software, load\_save pin or through serial ToD.

### 3.6.22 Adjustment of LTC Counter

LTC counter value can be adjusted by about a second without reloading a new LTC value. LTC value can be programmed to tune the current value by adding or subtracting a specific value. The offset adjustment can be positive or negative, very similar to 1 ns adjustment being positive or negative. An adjustment every 232 ns can be performed using LTC\_OFFSET\_ADJ. Additionally, an adjustment every 220 ns can be performed using LTC\_AUTO\_M\_x.

The purpose of this register is to add/subtract a programmable offset register of 30-bit width in ns, to the register block in order to cover the entire nanosecond portion of the 80-bit LTC. This offset control is independent of the LTC load control. The LTC timer is adjusted - added or subtracted as per the bit LTC\_OFFSET\_ADJ.LTC\_ADD\_SUB\_OFFSET, by the value LTC\_OFFSET\_ADJ.LTC\_OFFSET\_VAL, when a load offset command is issued by the software (assertion of LTC\_OFFSET\_ADJ.LTC\_OFFSET\_ADJ). The hardware sets the status bit LTC\_OFFSET\_ADJ\_STAT.LTC\_OFFSET\_DONE after completing the operation. However, in case the hardware cannot complete the operation because of the LTC value itself getting updated synchronously due to parallel or serial LTC load at the same time, it sets the bit LTC\_OFFSET\_ADJ\_STAT.LTC\_OFFSET\_LOAD\_ERR. The software on seeing either of these status bits set (LTC\_OFFSET\_ADJ\_STAT.LTC\_OFFSET\_DONE or LTC\_OFFSET\_ADJ\_STAT.LTC\_OFFSET\_LOAD\_ERR), de-asserts the control bit LTC\_OFFSET\_ADJ.LTC\_OFFSET\_ADJ and might potentially retry the operation.

The maximum value in nanoseconds for the offset LTC\_OFFSET\_ADJ.LTC\_OFFSET\_VAL can be up to  $10^9 - 1$ . Thus, for addition operation, the maximum carry to the seconds counter is 2 because of the clock period addition to this maximum value present in the offset and LTC nanoseconds counter. Subtraction operations should never be allowed because if the resultant subtraction is negative or underflows, the LTC timer gets set to the wrong value.

LTC\_OFFSET\_ADJ register (with LTC\_OFFSET\_VAL[29:0] and LTC\_ADD\_SUB\_OFFSET) should be updated before asserting LTC\_OFFSET\_ADJ bit in LTC\_OFFSET\_ADJ register.

LTC\_OFFSET\_ADJ\_STAT.LTC\_OFFSET\_DONE and LTC\_OFFSET\_ADJ\_STAT.LTC\_OFFSET\_LOAD\_ERR bits are set by the hardware and cleared by the software by writing a zero.

Should a conflict occur between LTC update due to parallel/serial load and LTC update due to offset adjustment, the load LTC takes precedence and the error condition is noted so that the polling software does not hang on the offset status bit assertion.

LTC counter could be adjusted for any known drift that occurs on every second. This feature will add or subtract one nanosecond every time LTC crosses over LTC\_AUTO\_ADJ\_M\_NS.

**Example 1.** If LTC\_AUTO\_ADJ\_M\_NS is 100 ns and LTC is started from reset with a value of 0 ns, then LTC counter will be added/subtracted 1 ns every time counter rolls over 100 ns.

**Example 2.** If LTC\_AUTO\_ADJ\_M\_NS is 100 ns and LTC is started from reset with a value of 0 ns, then LTC counter will be added/subtracted 1 ns every time counter rolls over. When counter is at 10 ns and LTC counter is loaded with 2 sec, 80 ns. Now 1 ns is adjusted when counter increments from 10 ns and rolls over 100 ns. It does not add/subtract when LTC timer rolls over 100 ns.

**Example 3.** LTC\_AUTO\_ADJ\_M\_NS value is loaded with 400 ns and after some time LTC\_AUTO\_ADJ\_M\_NS value is loaded with 500 ns. The AUTO\_ADJ\_M\_COUNTER value when the new value is loaded is 333 ns. Then the next adjustment happens after 177 ns after load because the AUTO\_ADJ\_M\_COUNTER continues to count until it reaches the newly loaded value 500 ns.

**Example 4.** LTC\_AUTO\_ADJ\_M\_NS value is loaded with 400 ns and after some time LTC\_AUTO\_ADJ\_M\_NS value is loaded with 100 ns. The AUTO\_ADJ\_M\_COUNTER value when the new value is loaded is 333 ns. Then adjustment happens immediately because  $333 > 100$  and the AUTO\_ADJ\_M\_COUNTER is reset to zero after the adjustment

If LTC counter is loaded with a new value, set LTC\_AUTO\_ADJ\_M\_UPDATE bit to 1 and reload the LTC\_AUTO\_ADJ\_M\_NS value.

### 3.6.23 Pulse per Second Output

The local time counter generates a one pulse-per-second (1PPS) output signal with a programmable pulse width routed to GPIO pins. The pulse width of the 1PPS signal is determined by the LTC\_1PPS\_WIDTH\_ADJ register.

When the LTC counter exceeds the value in PPS\_GEN\_CNT (both are in nanoseconds), the PPS signal is asserted. In default operation where PPS\_GEN\_CNT = 0 the LTC timer generates a PPS signal every time LTC crosses the 1 sec boundary. By writing a large value such as  $10^9$ -60 ns, the 1PPS pulse reaches its destination 60 ns away simultaneous with the LTC second wrap thus providing time-of-day synchronism between two systems.

The 1PPS output has an alternate mode of operation that increases the frequency of the pulses. This mode may be used for applications such as locking an external DPLL to the IEEE 1588 frequency. In the alternate mode the 1PPS signal is driven directly from a single bit of the nanosecond field counter of the local time counter. The pulse width can not be controlled in this alternate operation mode. The alternate mode is enabled with register LTC\_CTRL.LTC\_ALT\_MODE\_PPS\_BIT.

The output frequencies that result are 1 divided by powers of 2 nanoseconds (bit 4 = 1/32 ns, bit 5 = 1/64 ns, bit 6 = 1/128 ns, ...). The output pulses may jitter by the amount of the programmed nanoseconds of the adder to the local nanoseconds counter, and any automatic or one-shot adjustments.

The following table shows the possible output pulse frequencies (including the range of 4 kHz to 10 MHz) usable for external applications.

**Table 39 • Output Pulse Frequencies**

Nanosecond Counter Bit	Output Pulse Frequency
4	31.25 MHz
5	15.625 MHz
6	7.8125 MHz
7	3.90625 MHz
8	1.953125 MHz
9	976.5625 kHz
10	488.28125 kHz
11	244.140625 kHz
12	122.0703125 kHz
13	61.03515625 kHz
14	30.51757813 kHz
15	15.25878906 kHz
16	7.629394531 kHz

**Table 39 • Output Pulse Frequencies (continued)**

Nanosecond Counter Bit	Output Pulse Frequency
17	3.814697266 kHz

In addition to the preceding frequencies, a specific frequency can be chosen by enabling the synthesizer on the PPS pin using the following steps.

1. Set LTC\_FREQ\_SYNTH.LTC\_FREQ\_SYNTH\_EN to 1.
2. A toggle signal with the frequency specified will be pushed out onto PPS. The number of nanoseconds the signal stays high can be specified by LTC\_FREQ\_SYNTH.FREQ\_HI\_DUTY\_CYC\_NS. The number of nanoseconds the signal stays low can be specified by LTC\_FREQ\_SYNTH.FREQ\_LO\_DUTY\_CYC\_NS.
3. Set the FREQ\_HI\_DUTY\_CYC\_NS to 50 ns and FREQ\_LO\_DUTY\_CYC\_NS to 50 ns. On a 250 MHz LTC clock, this will make high time and low time of signal shift between 48 ns and 52 ns.

### 3.6.24 Accuracy and Resolution

The IEEE 1588 processor achieves time stamp resolution in any mode of operation of 1 ns utilizing special high-resolution circuitry. The accuracy of a device using high-resolution circuitry is improved more than 100% over the first generation IEEE 1588 engine. High accuracy for these devices will be supported regardless of the local time counter clock frequency supplied to the reference clock input. The timestamp accuracy is a system-level property and may depend upon oscillator selection, port type, and speed, system configuration, and calibration decisions. Supported frequencies of the local time counter are 125 MHz, 156.25 MHz, 200 MHz, and 250 MHz.

There are a total of five high resolution blocks per port to improve resolution for the following events:

- One pulse-per-second (1PPS) output signal
- 1588\_PPS\_RI input signal
- Start-of-frame in the egress direction
- Start-of-frame in the ingress direction
- 1588\_LOAD\_SAVE input (strobe) signal direction

Each of these blocks can individually be enabled using ACC\_CFG\_STATUS. Contact Microsemi with any questions regarding PTP accuracy calculations.

### 3.6.25 Loopbacks

Loopback options provide a means to measure the delay at different points to evaluate delays between on chip wire delays and external delays down to a nanosecond.

#### 3.6.25.1 Loopback from PPS to PPS\_RI Pin

In this loopback, an external device will connect the PPS coming out of the IEEE 1588 to PPS\_RI of the IEEE 1588 device. The external device could even process the PPS signal and then loopback at a far-end.

#### 3.6.25.2 Loopback from LOAD\_SAVE to PPS

When LOAD\_SAVE\_PPS\_LPBK\_EN is set, input load\_save pin is connected to output PPS coming out of the IEEE 1588. In this mode, input load\_save pin is taken as close to the pin as possible without going through any synchronization logic on the load\_save pin.

#### 3.6.25.3 Loopback of LOAD\_SAVE Pin

When LOAD\_SAVE\_LPBK\_EN is set, one clock cycle before the PPS is asserted, an output enable for load\_save pin is generated and PPS signal is pushed out on the load\_save pin acting as an output pin. After two cycles, output enable is brought down and load\_save will behave as an input pin.

#### 3.6.25.4 Loopback from PPS to LOAD\_SAVE Pin

When PPS\_LOAD\_SAVE\_LPBK\_EN bit enabled, output pps signal is taken as close to the I/O as possible and looped back onto load\_save input pin. This is to account for any delays from PPS generation block to the PPS output pin.

### 3.6.26 Accessing 1588 IP Registers

**Note:** Contact Microsemi for an initialization script that supports the quick initialization of IEEE 1588 registers.

## 3.7 Flow Control Buffers

Flow control buffers are used in the data paths when the MACs are enabled. Ethernet frames are stored in the buffers. When a buffer is close to being full, the MAC will issue a pause frame to the device sending data to the VSC8257-01 device. This is done to prevent the data path's flow control buffer from overflowing.

The flow control feedback is particularly common for the host interface when in 10G WAN mode due to the transmitted line WAN data rate being less than the received host LAN data rate.

## 3.8 Rate Compensating Buffers

Rate compensating buffers are used in the data paths when the MACs are disabled. The rate compensating buffers add and drop idle characters between Ethernet packets when necessary to address clock rate differences between the line-side and host-side interfaces. Rate offsets from ideal frequencies measured in ppm (not MHz) can be tolerated.

The maximum data throughput on the line interface is less in 10G WAN mode than 10G LAN mode. The line's data rate is reduced to 9.953 Gbps from 10.3125 Gbps. Part of that bandwidth includes SONET/SDH frame overhead data. Care must be taken by the device sending data to the host interface in the egress data path to ensure the rate compensating buffer does not overflow.

## 3.9 Loopback

The VSC8257-01 device has several options available to the user for routing traffic between the host-side and the line-side. The following table shows the name and location of the loopback modes. These modes may be extremely useful for both test and debug purposes.

**Note:** When looping back the traffic from ingress of the PHY SFI input to egress of the PHY SFI output, the jumbo frame will not work. If the application requires looping back the traffic external to the PHY on the host side, the loopback has to contain the scheduler to throttle the egress traffic with the compliance of the stretch ratio (13:1) required by WAN mode, as defined in the IEEE 802.3ae specification.

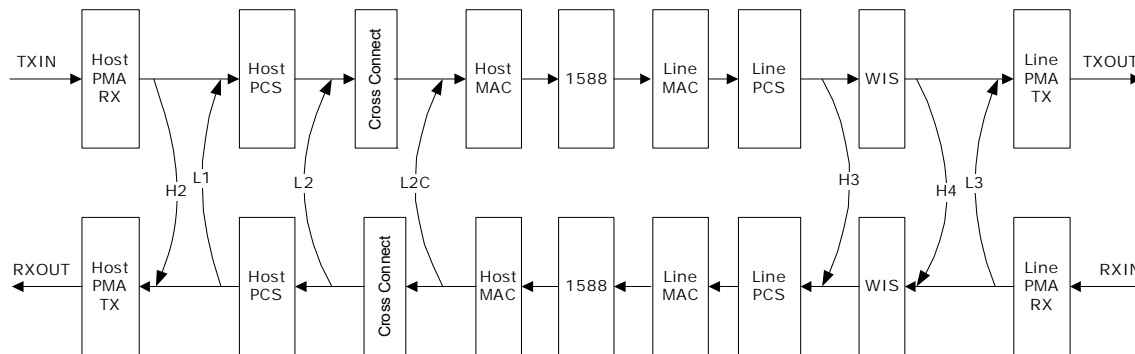
**Table 40 • Line-Side Loopbacks**

Name	Location
L1	Host PCS after the gearbox (10G)
L2	XGMII interface (1G and 10G)
L2C	XGMII interface (1G and 10G)
L3	Line PMA interface (1G and 10G)

**Table 41 • Host-Side Loopbacks**

Name	Location
H2	Host PMA interface (1G and 10G)
H3	Line PCS after the gearbox (10G)
H4	WIS-line PMA interface (10G)

The following illustration shows the host and line-side loopbacks.

**Figure 64 • Host-Side and Line-Side Loopbacks**


### 3.10 Cross Connect

Cross-connect is placed between the host PCS (and packet BIST) and the MAC/FIFOs. It interconnects any of the 4 channels with one another, and each output is independently configurable. Since it switches in the XGMII-64 interface layer, PCS link status is not affected by a switch (although corrupted packets are certainly possible).

In addition to switching manually through the management interface, cross-connect allows for automatic switching based on various events. To avoid false switching, it is highly recommended that customers qualify the event and program the cross connect switching accordingly. For more information, contact a Microsemi representative. The list of events includes PCS block-lock on both host and client in both 10G and 1G mode, loss of alignment from the line side WIS, and external GPIO inputs (LOS from a module, for example). The events that affect each mux, the assertion state of that event, and its priority are configurable.

Because any of the four ports may be interconnected, 1:N protection may be possible.

**Note:** When cross connect is used, all ports should be sourced from the same local reference clock.

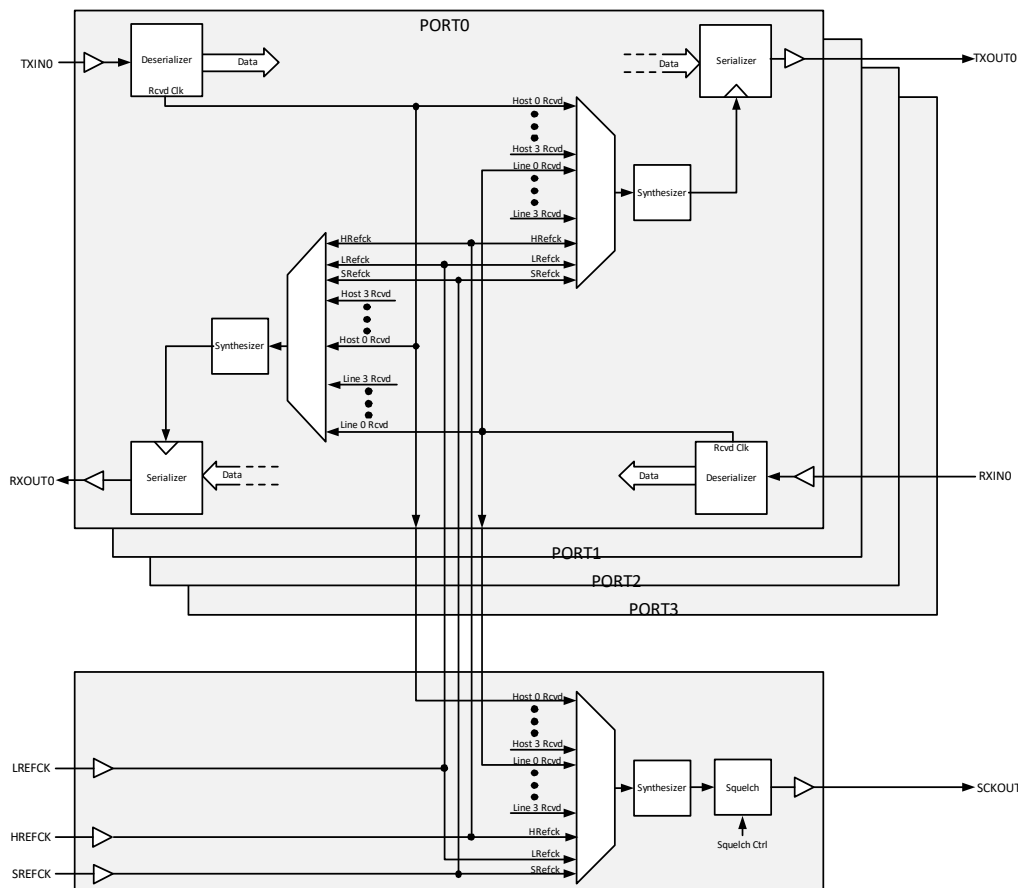
**Note:** The switching function is not hitless, and it will result in the momentary fragmentation of packets.

### 3.11 Host-Side Interface

The host interface of VSC8257-01 consists of the same PMA block utilized on the line side. This interface has the same capabilities and feature set as the line side PMA discussed earlier.

### 3.12 Clocking

A flexible clocking architecture allows for various synchronous Ethernet (Sync-E) configurations as well as per-port receive clock (repeater mode) timing. By default, the timing of each transmit interface is based on the local oscillator (LREFCK). However, each transmit interface may be independently synchronized to any one of several clock sources. The following illustration shows the port timing architecture.

**Figure 65 • Port Timing Architecture**


Any individual transmitter can be synchronized to the recovered clock of any receiver, line or host sides. In a typical Ethernet application, no special clocking configuration is required and all transmitters are synchronized to the local reference clock, LREFCK.

In repeater mode, each individual transmitter must be synchronized to the recovered clock of the receiver on the opposite side (for example, RXOUT0 output will be synchronized to the recovered clock from the RXIN0 input). This is the Lane Sync feature described in [Physical Media Attachment \(PMA\)](#), page 10.

**Note:** Lane Sync cannot be enabled during either (dual sided) KR auto-negotiation (clause 73) and link training (clause 72) operation or failover switching and cross connect operations ([Cross Connect](#), page 101).

For Sync-E applications, additional circuitry is available to support multiple possible configurations.

### 3.12.1 Synchronous Ethernet Support

In addition to the local reference clock input, LREFCK (which is required in any case), a second, optional reference clock, SREFCK, is available. SREFCK may be used as an alternate synchronization source when LREFCK is a simple local oscillator. SREFCK includes filtering to smooth out changes in frequency (on a clock source switch, for example). LREFCK does not include this capability; if using LREFCK as the clock source in Sync-E applications, care must be taken to ensure that switching clock sources is glitch-less.

#### 3.12.1.1 SyncE Output Clock

Any recovered clock can be selected for the clock output from a dedicated Sync-E output clock, SCKOUT. SCKOUT also includes a synthesizer that can be used to generate a Sync-E-friendly clock rate regardless of the line-rate. In 10G LAN applications, for example, it can generate a 156.25 MHz clock derived from the 10.3125 GHz recovered clock. It can also generate a 156.25 MHz clock derived from the 9.95328 GHz recovered clock in a 10G WAN system.

SCKOUT also includes a squelch function that can be used to configure the device to squelch (drive to a constant state) upon detecting certain conditions, such as loss of link on a PCS, or the state of a GPIO input.

The device supports several synchronous Ethernet (SyncE) configurations. In SyncE applications, typically a single master clock for all transmit interfaces is selected from multiple potential sources.

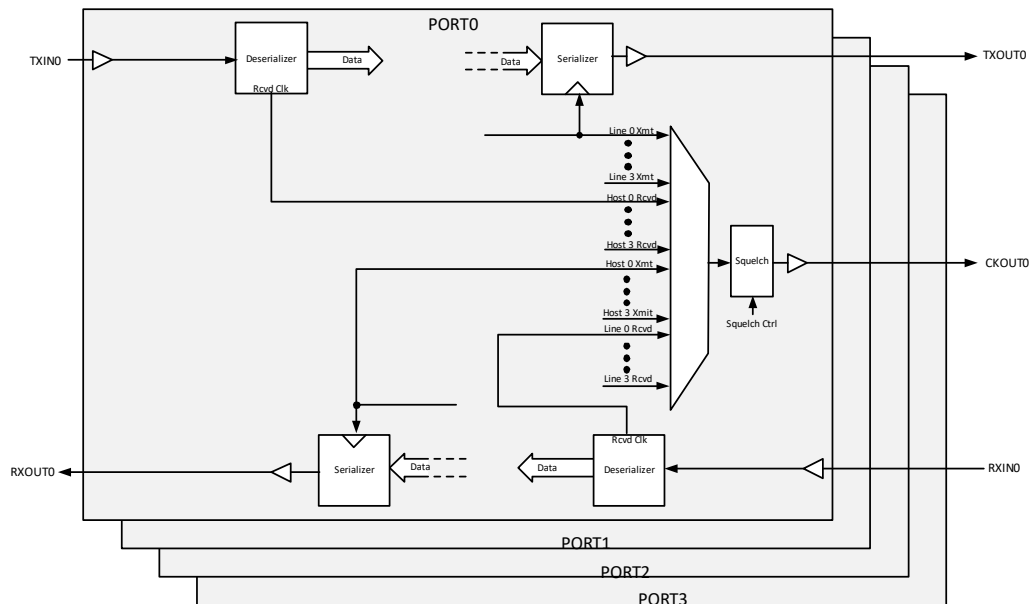
- **Single device, internal master:** The line-side Rx captures the serial data input and generates a clock signal that is then distributed to all ports of the line-side transmitter (Tx), creating a source-synchronous function.
- **Single clock LAN, external master:** The LREFCK frequency is gradually changed to the externally generated SyncE clock frequency using an external clock distribution chip. The change must be hitless to avoid data corruption. The LREFCK source may come from one of the recovered clocks using a CKOUT pin or SCKOUT.
- **Dual clock LAN, external master:** The LREFCK remains connected to the stable 156.25 MHz system clock or crystal. All line-side transmits are synchronized to SREFCK. One of the CKOUT pins (161.13 MHz) or the SCKOUT pin (156.25 MHz) provides a recovered clock reference to the external master.
- **Dual clock WAN, external master:** LREFCK remains connected to the stable 156.25 MHz system clock or crystal. All line side transmits are synchronized to SREFCK (155.52 MHz). SCKOUT provides a recovered clock (156.25 MHz or 155.52 MHz) to be used as a reference to the external master.

### 3.12.1.2 Output Clocks

In addition to the SCKOUT output, another clock output for each port, CKOUT[0:3], may be connected to any port's transmit clock or recovered clock. When connected to a transmit clock, it may be used to drive clocked optical modules. In Sync-E applications, it may be used (in lieu of SCKOUT) to provide a recovered clock to an external timing master.

The following illustration shows the per-port clock outputs.

**Figure 66 • Per-Port Clock Outputs**



The rate of these clocks is the line rate divided by 32 or 64 (322.27 MHz or 161.13 MHz in 10G LAN mode, for example). There is no provision to synthesize a Sync-E-friendly rate on CKOUT[0:3]. However, should it be acceptable in a Sync-E application, the same clock squelching capability found on SCKOUT is available.



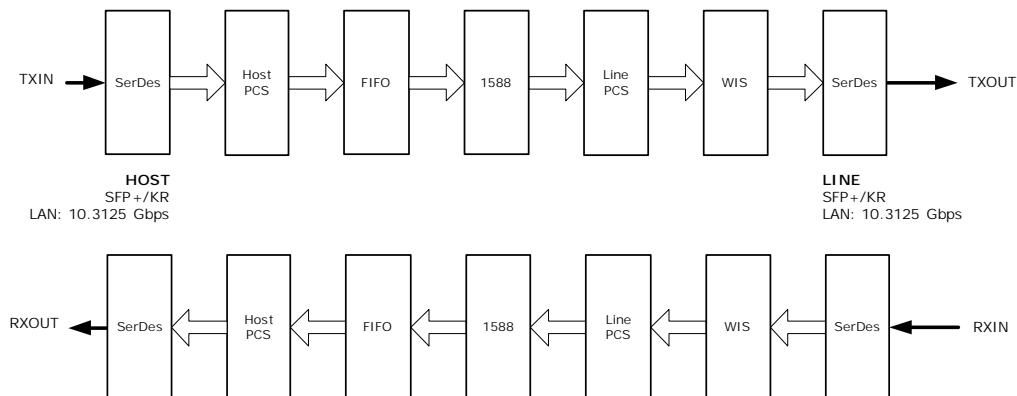
## 3.13 Operating Modes

The VSC8257-01 device has three main operation modes: 10G LAN, 10G WAN, and 1 GbE. Each mode may have the 1588 blocks on or off.

### 3.13.1 10G LAN with 1588

In 10G LAN mode with 1588, the host and line interfaces are LAN SFP+ (10.3125 Gbps). LREFCK and HREFCK are used by the line-side and host-side interfaces respectively, to transmit appropriate rates. For more information about supported reference clock frequencies, see [Table 3](#), page 10. Rate compensation is done in the FIFO.

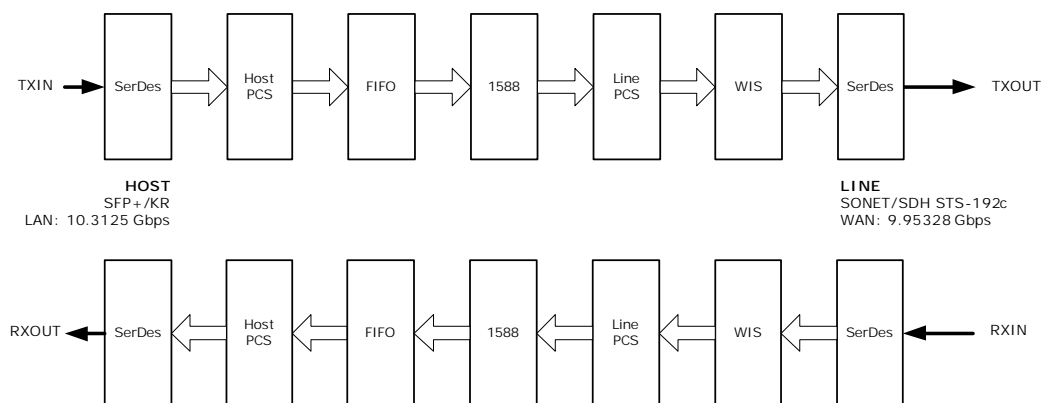
**Figure 67 • 10G LAN with 1588**



### 3.13.2 10G WAN with 1588

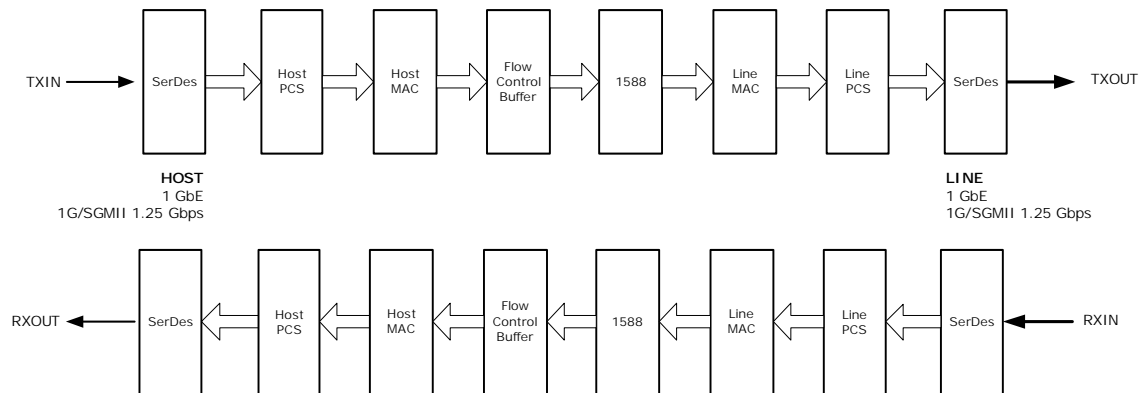
In 10G WAN mode with 1588, the host interface is LAN SFP+ (10.3125 Gbps) and the line interface is SONET/SDH STS-192c (9.95328 Gbps). LREFCK and HREFCK are used by the line-side and host-side interfaces respectively, to transmit appropriate rates. For more information about supported reference clock frequencies, see [Table 3](#), page 10. A 622 MHz SREFCK reference frequency is not supported. Rate compensation is done in the FIFO.

**Figure 68 • 10G WAN with 1588**



### 3.13.3 1 GbE with 1588 and MACs

In 1 GbE mode with 1588 and MACs, the signal through the host and line interfaces is 1.25 Gbps. LREFCK and HREFCK are used by the line-side and host-side interfaces respectively, to transmit appropriate rates. For more information about supported reference clock frequencies, see [Table 3](#), page 10. MACs should be enabled to meet the pause turn around time spec as defined in the IEEE specifications.

**Figure 69 • 1 GbE with 1588 and MACs**

## 3.14 Management Interfaces

This section contains information about the low-speed serial interfaces of the VSC8257-01 device. The primary control and monitor interfaces in the design are as follows:

- MDIO
- SPI slave
- Two-wire serial (slave)
- Two-wire serial (master)
- Push out SPI master for IEEE 1588 time stamp data
- GPIO
- JTAG

The VSC8257-01 device supports three different interfaces for accessing status and configuration registers: MDIO, SPI slave, and two-wire serial slave. Only one of the interfaces can be active at a time. The VSC8257-01 device doesn't arbitrate between these interfaces. Users must exercise caution and ensure that multiple interfaces are not active at the same time.

The SPI slave interface is the recommended interface for accessing the status and configuration registers of the 1588 block and the IEEE 1588 time stamp data

The VSC8257-01 device registers are arranged according to the MDIO devices as defined in IEEE 802.3 clause 45, as shown in the following list:

- Device 1: Line PMA and line interface registers
- Device 2: WIS registers
- Device 3: Line 10G PCS, line 1G PCS, host 1G PCS, FC buffers, line MAC, and host MAC registers
- Device 4: Rate compensating registers
- Device 7: Line 10GBASE-KR registers
- Device 9: Host PMA and host interface registers
- Device B: Host 10G PCS registers
- Device F: Host 10GBASE-KR registers
- Device 1E: Global, SFP+, PLLs, GPIOs, cross-connect and 1588 registers

### 3.14.1 MDIO Interface

The MDIO interface in the VSC8257-01 device complies with IEEE 802.3ae Clause 45. For more information, see the IEEE standard. The MDIO management interface consists of a bi-directional data path (MDIO) and a clock reference (MDC).

MDIO instructions can be used to read registers, write registers, and perform post-read-increment-address instructions. Due to its slow bandwidth and high latency, the MDIO interface is not recommended as the only interface to access the VSC8257-01 device.

**Note:** The maximum data rate of the MDIO interface is 2.5 Mbps.

The PADDR[4:2] pins select the MDIO port addresses to which the VSC8257-01 device will respond. A single VSC8257-01 device requires the use of four MDIO port addresses, one for each channel. The port

address transmitted in MDIO read/write commands to access registers in a particular VSC8257-01 channel is shown in the following table. The port address is a function of the PADDR pins and a pre-programmed number indicating the channel number. Up to eight VSC8257-01 devices can be controlled by a single MDIO host.

**Table 42 • MDIO Port Addresses Per Channel**

Channel Number	Channel's Port Address
3	{PADDR[4:2], 11}
2	{PADDR[4:2], 10}
1	{PADDR[4:2], 01}
0	{PADDR[4:2], 00}

### 3.14.1.1 Accessing 32-Bit Data Registers

Even though the MDIO interface is defined to access 16-bit data registers, 32-bit configuration and status registers are present in the line and host MACs in 1G mode, 1588, and line-side SerDes. Use the following steps when accessing registers in 32-bit blocks.

#### 3.14.1.1.1 Write to 32-Bit Register

1. Issue address instruction specifying the MDIO address for bits [31:16].
2. Issue write instruction to write data to register bits [31:16].
3. Issue address instruction specifying the MDIO address for bits [15:0].
4. Issue write instruction to write data to register bits [15:0].

**Note:** Writing to the two halves of the 32-bit register in the opposite order is not permitted. Nor is it possible to write to only one-half of the register. All four MDIO instructions must be issued to write to a 32-bit register.

#### 3.14.1.1.2 Read 32-Bit Register

1. Issue address instruction specifying the MDIO address for bits [15:0].
2. Issue read-increment instruction. The data read is the contents of register bits [15:0].
3. Issue read instruction. The data read is the contents of register bits [31:16].

**Note:** Perform all three steps to read a 32-bit register even when reading consecutive addresses. Issuing back-to-back read-increment instructions to read consecutive 32-bit register addresses is not supported.

Register addresses listed for the line and host MACs 1588, and SerDes apply to the SPI slave and two-wire serial slave interfaces, which support direct access to 32-bit data registers. There are two MDIO addresses for each of these 32-bit data registers: one address to access data bits [31:16] and one address to access data bits [15:0]. Contact Microsemi for support using the MDIO interface to access line and host MACs 1588, and SerDes registers.

## 3.14.2 SPI Slave Interface

The VSC8257-01 device supports the serial peripheral interface (SPI) for reading and writing registers for high bandwidth tasks such as reading IEEE 1588 time stamp data. The SPI interface is also capable of accessing all status and configuration registers. The SPI slave port consists of a clock input (SCK), data input (MOSI), data output (MISO), and slave select input (SSN).

**Note:** The SPI slave interface is the recommended interface to access status and configuration registers for the rest of the device.

Drive the SSN pin low to enable the interface. The interface is disabled when SSN is high and MISO is placed into a high impedance state. The VSC8257-01 device captures the state of the MOSI pin on the rising edge of SCK. 56 data bits are captured on the MOSI pin and transmitted on the MISO pin for each SPI instruction. The serial data bits consist of 1 read/write command bit, 23 address bits, and 32 register data bits.

The 23-bit addressing scheme consists of a 2-bit channel number, a 5-bit MDIO device number, and a 16-bit register number. For example, the 23-bit register address for accessing the GPIO\_0\_Config\_Status register in channel 1 (device number is 0x1E and register number is 0x0100) is

0x3E0100. The notion of device number conforms to MDIO register groupings. For example, device 2 is assigned to WIS registers.

The following table shows the order in which the bits are transferred on the interface. Bit 55 is transferred first, and bit 0 is transferred last. This sequence applies to both the MOSI and MISO pins.

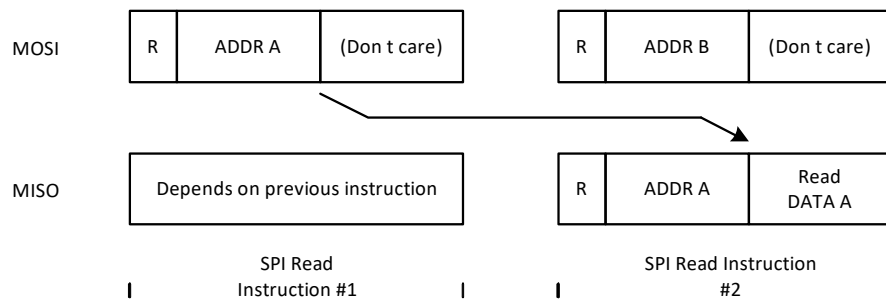
**Table 43 • SPI Slave Instruction Bit Sequence**

Bit	Name	Description
55	Read/Write	0: Read 1: Write
54:53	Port/Channel Number	00: Port/Channel 0 01: Port/Channel 1 10: Port/Channel 2 11: Port/Channel 3
52:48	Device Number	5-bit device number Bit 4 corresponds to SPI instruction bit 52 Bit 0 corresponds to SPI instruction bit 48
47:32	Register Number	16-bit register number Bit 15 corresponds to SPI instruction bit 47 Bit 0 corresponds to SPI instruction bit 32
31:0	Data	32-bit data Bit 31 corresponds to SPI instruction bit 31 Bit 0 corresponds to SPI instruction bit 0

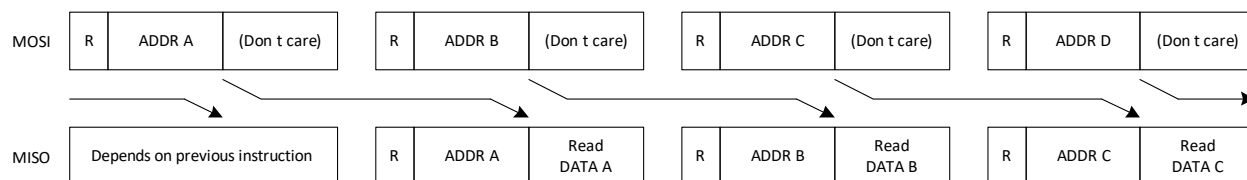
The register data received on the MOSI pin during a write operation is the data value to be written to a VSC8257-01 register. Register data received on the MOSI pin during a read operation is not used, but must still be delivered to the device.

The VSC8257-01 device SPI slave has a pipelined read process. Two read instructions must be sent to read a single register. The first read instruction identifies the register address to be read. The MISO data transmitted on the second read instruction contains the register contents from the address specified in the first instruction. While a pipelined read implementation is not the most efficient use of bandwidth to read a single register, it is very efficient when performing multiple back-to-back reads as would be the case when reading 1588's TSFIFO\_\* registers. The second read instruction contains the address for the second register to be read plus the data read from the first register. The third read instruction contains the address for the third register to be read plus the data read from the second register. Register reads can continue in this fashion indefinitely. The following illustrations show the situations where back-to-back read instructions are issued.

**Figure 70 • SPI Single Register Read**

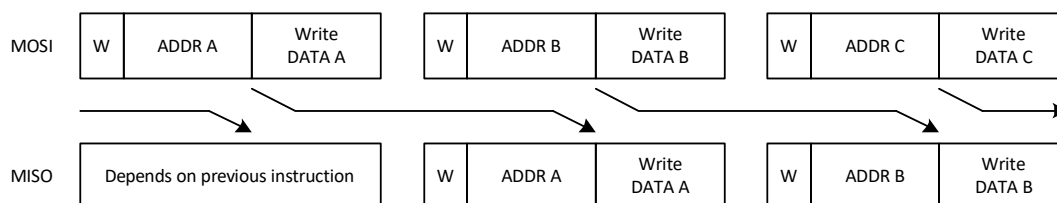


**Figure 71 • SPI Multiple Register Reads**



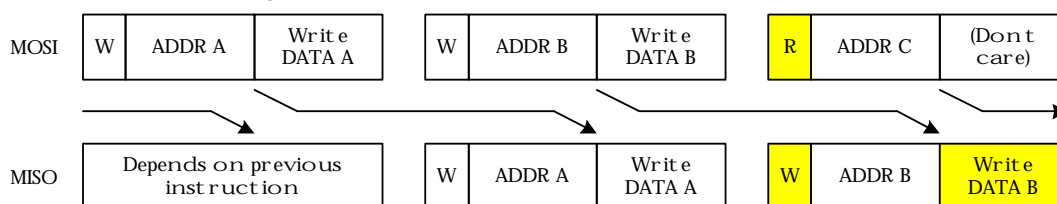
The SPI read instruction figures also point out the read/write state and address bits on the MISO output match the information received in the previous instruction. The SPI master could use this data to verify the device captured the previous instruction properly, or simply ignore the data. The following illustration shows the MISO output during write instructions reporting the previous instruction's read/write state, address, and register write data.

**Figure 72 • SPI Multiple Register Writes**



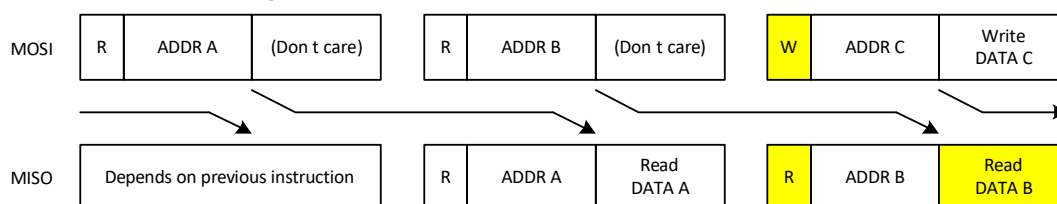
The following illustration shows that when a read instruction follows a write instruction, the MISO data during the read instruction is the data field from the previous write.

**Figure 73 • SPI Read Following Write**



The following illustration shows that when a write instruction follows a read instruction, the MISO data during the write instruction is not pipelined read data. MISO contains all 0's in the data field.

**Figure 74 • SPI Write Following Read**



Some VSC8257-01 registers are made up of less than 32 data bits. Any bits not defined for a register will return a 0 when the register is read. Reading an invalid register address will return 0x0.

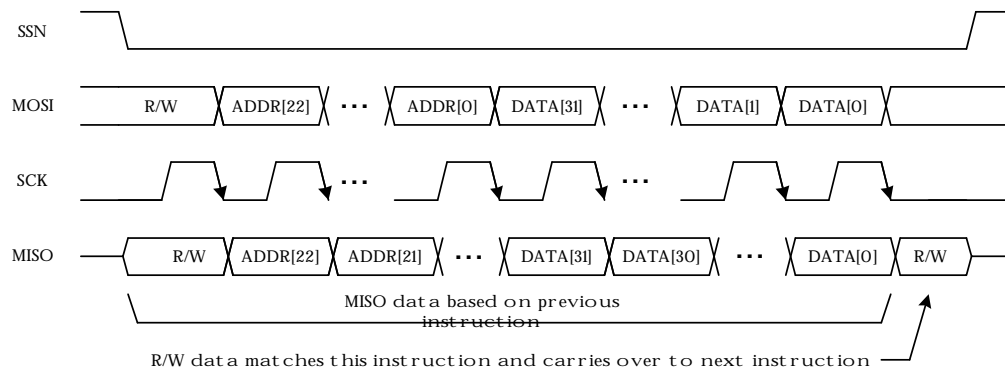
There is one hazard condition to be aware of when issuing two read instructions to read a single clear-on-read register. Issuing two read instructions internally fetches data twice even though valid read data is present only in the second instruction. Fetching data also resets a clear-on-read register. The address specified in the second read instruction should be something other than the clear-on-read register address. This prevents an event causing register re-assertion occurring between the two read instructions from being cleared and never detected. The address in the second instruction can be any register not having a clear-on-read function. Device\_ID is one example. The same address can be used in each read instruction when continuously polling a clear-on-read register. This works because subsequently fetched data is transmitted from the interface allowing assertion between reads to be detected. Only the last read instruction where fetched data is not transmitted should some other address in the instruction be used.

### 3.14.2.1 MISO Output Timing Modes

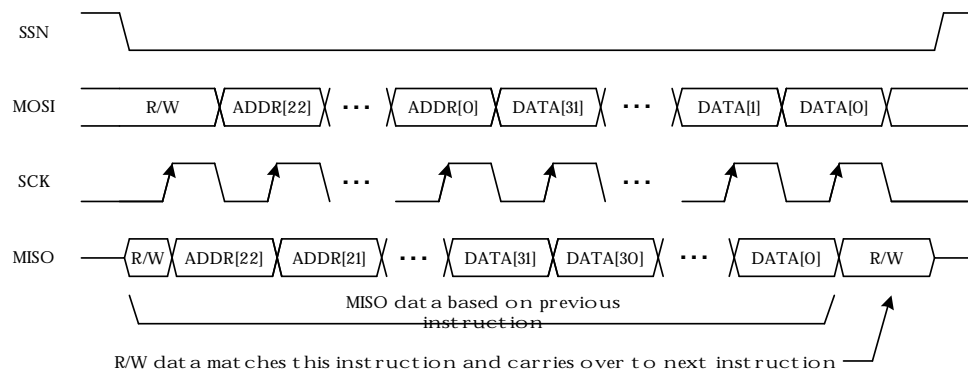
MISO changes state when SCK transitions from high to low in the default SPI operating mode. This aids in meeting hold time at the SPI master assuming the master captures the data on the rising SCK edge. The SPI port can run up to a maximum of 30 Mbps depending upon the VSC8257-01 device SCK-to-MISO timing, MISO loading SCK duty cycle, the board layout, and the external SPI master's interface timing requirements. For more information about SPI timing, see Table 64, page 129.

The SPI slave port has an alternate operating mode that allows the interface to run faster. Setting register bit SPI\_CTRL.FAST\_MODE=1 configures the SPI slave such that MISO changes state when SCK transitions from low to high. Thus, data is both transmitted from the SPI slave and captured by the SPI master on a rising SCK edge. The interface can run faster in this mode by using the entire SCK clock period instead of half the period to transfer data from the slave to the master. Care must be taken to ensure the SPI master's hold time requirement is met. The following illustrations show MISO timing in the default and slave modes.

**Figure 75 • SPI Slave Default Mode**



**Figure 76 • SPI Slave Fast Mode**



MISO output timing is the only difference between the two SPI modes. Sampling of MOSI on the rising SCK clock edge remains the same so writing to the VSC8257-01 device registers is identical in both modes. Thus the SPI\_CTRL.FAST\_MODE register setting may be modified using the SPI slave port to change the port's MISO output timing.

### 3.14.3 Two-Wire Serial (Slave) Interface

The VSC8257-01 device registers may be read and written using a two-wire serial slave interface. The two-wire serial slave SCL and SDA pins are multifunction general purpose I/O (GPIO) pins, GPIO\_33 and GPIO\_32, respectively. The GPIO pins are configured to serve SCL and SDA functions following device reset.

The slave address assigned to the VSC8257-01 device is a function of four fixed values and the MDIO port address pins. The 7-bit slave address is {1000, PADDR4, PADDR3, PADDR2}. The use of the port address pins allows multiple VSC8257-01 devices to be serviced by a single two-wire serial (master). The maximum data transfer rate for the interface is 400 kbps.

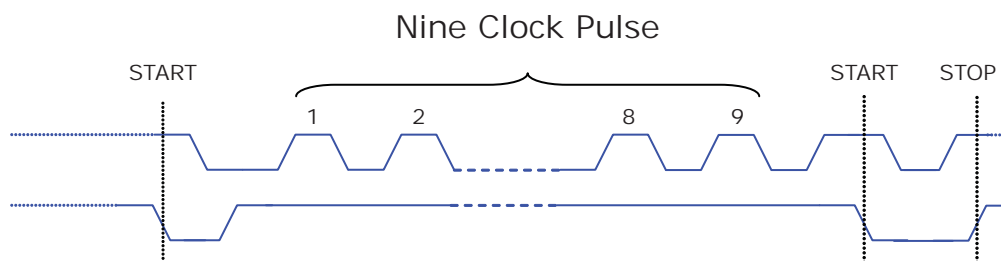
**Note:** The two-wire serial slave interface does not work with two-wire serial masters using 10-bit slave addresses.

A valid START condition is generated by a two-wire serial master device by transitioning the SDA line from high to low while the SCL line is high. Data is then transferred on the SDA line, most significant bit (MSB) first, with the SCL line clocking data. Data transitions during SCL low periods are valid (read) or latched (write) when SCL pulses high then low. Data transfers are acknowledged (ACK) by the receiving device for data writes and by the master for data reads. An acknowledge is signaled by holding the SDA signal low while pulsing SCL high then low. The master terminates data transfer by generating a STOP condition by transitioning SDA low to high while SCL is high.

**Note:** If the external two-wire serial master device gets out of sync with the two-wire serial slave interface, the master device must issue a bus reset sequence. This puts the two-wire serial slave interface back into a state that allows it to receive future two-wire serial instructions. The external two-wire serial master device and the two-wire serial slave interface can become out-of-sync and freeze the bus if either device is reset during an instruction.

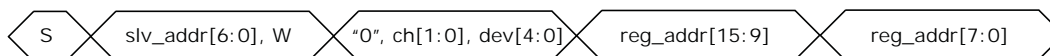
The following illustration shows a two-wire serial bus reset sequence. The reset sequence consists of a START symbol, nine SCK clock pulses while SDA is high, another START symbol, and a STOP symbol.

**Figure 77 • Two-Wire Serial Bus Reset Sequence**



Registers in the VSC8257-01 device are accessed using the 24-bit addressing scheme. The first 8 bits consist of one logic LOW, the channel number (00, 01, 10, 11), and the 5-bit MDIO device number of the register to be accessed. The next 16 bits are the register number. For example, the 24-bit register address for accessing the GPIO\_0\_Config\_Status register in channel 1 (device number 0x1E and register number 0x0100) is 0x3E0100. The notion of device number conforms to MDIO register groupings. For example, device 2 is assigned to WIS registers. The following illustration shows the 24-bit addressing scheme used to access registers.

**Figure 78 • Two-Wire Serial Slave Register Address Format**

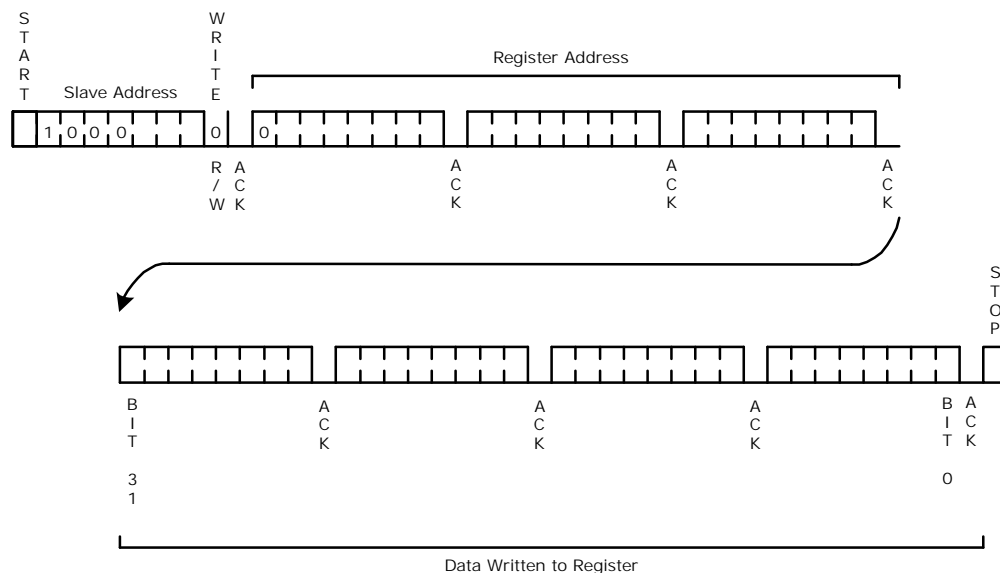


An illegal two-wire serial slave read instruction to an invalid channel number, device number, or register address will return a read value of 0x0000 when the slave address matches this device.

Four bytes of data are transferred on the two-wire serial bus after the address when a register is read or written. Data register bits [31:24] are transferred first, followed by bits [23:16], bits [15:8], and finally bits [7:0]. An ACK symbol is sent between each byte of data. Any bits not defined in a register will return a 0 when the register is read.

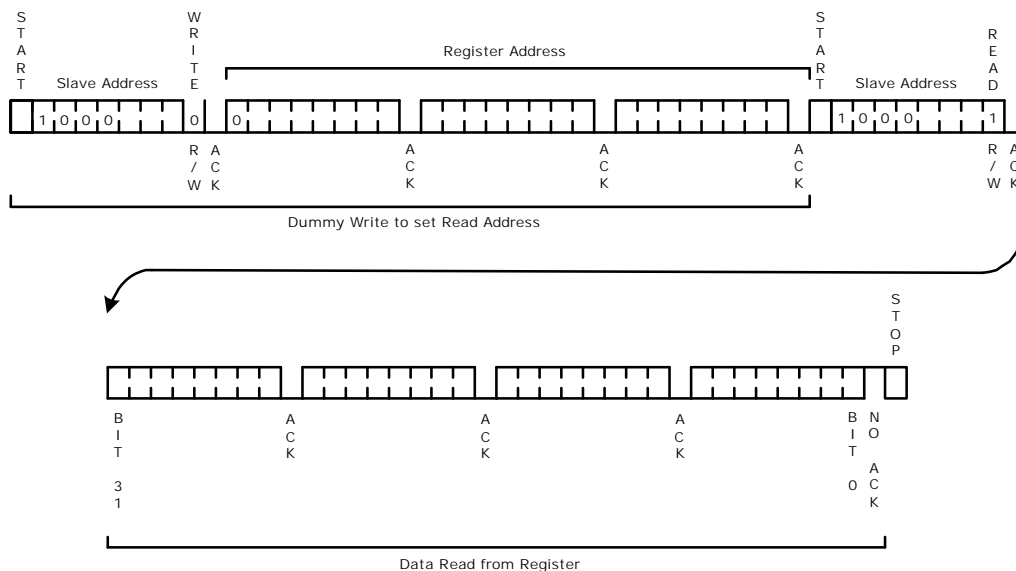
The following illustration shows the data transferred on the SDA pin during a register write operation. The R/W bit following the slave address is set to logic low to specify a write operation.

**Figure 79 • Two-Wire Serial Write Instruction**



The register address to be accessed is specified by initiating a write operation. After the slave address and three register address bytes are sent to the VSC8257-01 device, a START condition must be re-sent, followed by the slave address with the read/write bit set to logic high. The four-byte data register contents are then transmitted from the VSC8257-01 device. The two-wire serial (master) sends NO ACK after the fourth data byte to indicate it has finished reading data. The following illustration shows data transferred on the SDA pin during a register read operation.

**Figure 80 • Two-Wire Serial Read Instruction**



The two-wire serial slave interface supports sequential read and sequential write instructions.

### 3.14.4 Two-Wire Serial (Master) Interface

A two-wire serial master interface in the VSC8257-01 channel is available for SFP+/XFP module management. A two-wire serial master interface per channel is required because the slave address in the optics modules are identical. Two-wire serial interface instructions used to access optics module registers are initiated by writing to VSC8257-01 registers. The two-wire serial interface busses are brought out through GPIO pins by configuring the desired GPIO pins to function as SDA and SCL.



The two-wire serial master interface must be configured before initiating any instructions. The slave ID to be transmitted in the first byte of every instruction is selectable in the SLAVE\_ID register. The default setting is 0x50. The interface's data rate is determined by the PRESCALE register. The default data rate is 400 kbps.

The two-wire serial master transmits instructions for slave devices with 8-bit data registers and 256 register addresses per slave ID. Always read register I2C\_BUS\_STATUS.I2C\_BUS\_BUSY or I2C\_READ\_STATUS\_DATA.I2C\_BUS\_BUSY to verify the previous instruction has finished prior to initiating a new instruction. Instructions initiated when the interface is busy will be ignored. Both registers report the same interface busy status. The same busy status is reported in two registers for user convenience.

The two-wire serial master initiates a write instruction when the I2C\_WRITE\_CTRL register is written. The value written to I2C\_WRITE\_CTRL.WRITE\_ADDR is the register address to be modified in the slave device. The value written to I2C\_WRITE\_CTRL.WRITE\_DATA is the data to be written to the slave device's register. The I2C\_BUS\_STATUS register reports the status of the write instruction. I2C\_BUS\_STATUS.I2C\_BUS\_BUSY indicates when the instruction has finished. I2C\_BUS\_STATUS.I2C\_WRITE\_ACK=1 means the two-wire serial master received ACKs from the slave at appropriate times. I2C\_BUS\_STATUS.I2C\_WRITE\_ACK is cleared each time a new instruction is issued. If the two-wire serial master did not receive ACKs from the slave at appropriate times (I2C\_BUS\_STATUS.I2C\_WRITE\_ACK=0), the interface is likely stuck in a state waiting for the ACK. Writing a 1 to the BLOCK\_LEVEL\_RESET1.I2CM\_RESET register will reset the two-wire serial master and release it from its stuck state. The slave device should then be put into a known state by writing any value to the I2C\_RESET\_SEQ register. The two-wire serial master issues a bus reset sequence when this register is written. For more information, see [Two-Wire Serial \(Slave\) Interface](#), page 109.

The two-wire serial master initiates a read instruction when the I2C\_READ\_ADDR register is written. The value written to I2C\_READ\_ADDR.READ\_ADDR is the register address to be accessed in the slave device. I2C\_READ\_STATUS\_DATA.READ\_DATA contains the data read from the slave device. READ\_DATA is not valid until I2C\_READ\_STATUS\_DATA.I2C\_BUS\_BUSY=0 to indicate the instruction completed. The two-wire serial master does not support read-increment instructions.

### 3.14.5 Push Out SPI Master Interface

To overcome MDIO speed limitations for faster or large amounts of time stamp reads, the VSC8257-01 device supports a push out SPI master interface. The SPI output is used to push out time stamp information to an external device only and does not provide read/write to the rest of the status and configuration registers. For more information, see [Serial Time Stamp Output Interface](#), page 91.

The push out SPI master interface consist of SPI\_CLK\_01, SPI\_DO\_01 and SPI\_CS\_01 to generate 1588 times tamps for channels 0 and 1, and SPI\_CLK\_23, SPI\_DO\_23 and SPI\_CS\_23 to generate 1588 time stamps for channels 2 and 3.

### 3.14.6 JTAG

The VSC8257-01 device has an IEEE 1149.1–2001 compliant JTAG interface. The following table shows the supported instructions and corresponding instruction register codes. The code's least significant bit is shifted into TDI first when loading an instruction (the 0 is shifted in first when loading the IDCODE instruction).

**Table 44 • JTAG Instructions and Register Codes**

Instruction	Register Code	Notes
IDCODE	1111111111111111111111110	
BYPASS	1111111111111111111111111	
EXTEST	11111111111111111111101000	
EXTEST_PULSE	1111111011111111111101000	
EXTEST_TRAIN	11111110111111111111101000	
SAMPLE	11111111111111111111111000	

**Table 44 • JTAG Instructions and Register Codes (continued)**

Instruction	Register Code	Notes
PRELOAD	11111111111111111111000	
LV_HIGHZ	111111111111111111001111	Provides the ability to place outputs in a high impedance state to facilitate manufacturing test and PC board diagnostics. The SFP+ serial data outputs are not put into the high impedance state when this instruction is loaded in the JTAG TAP controller.
CLAMP	111111111111111111101111	Provides the ability to place all outputs in a predefined state when the scan process is being used to test other devices on a PC board.

### 3.14.7 General Purpose I/O

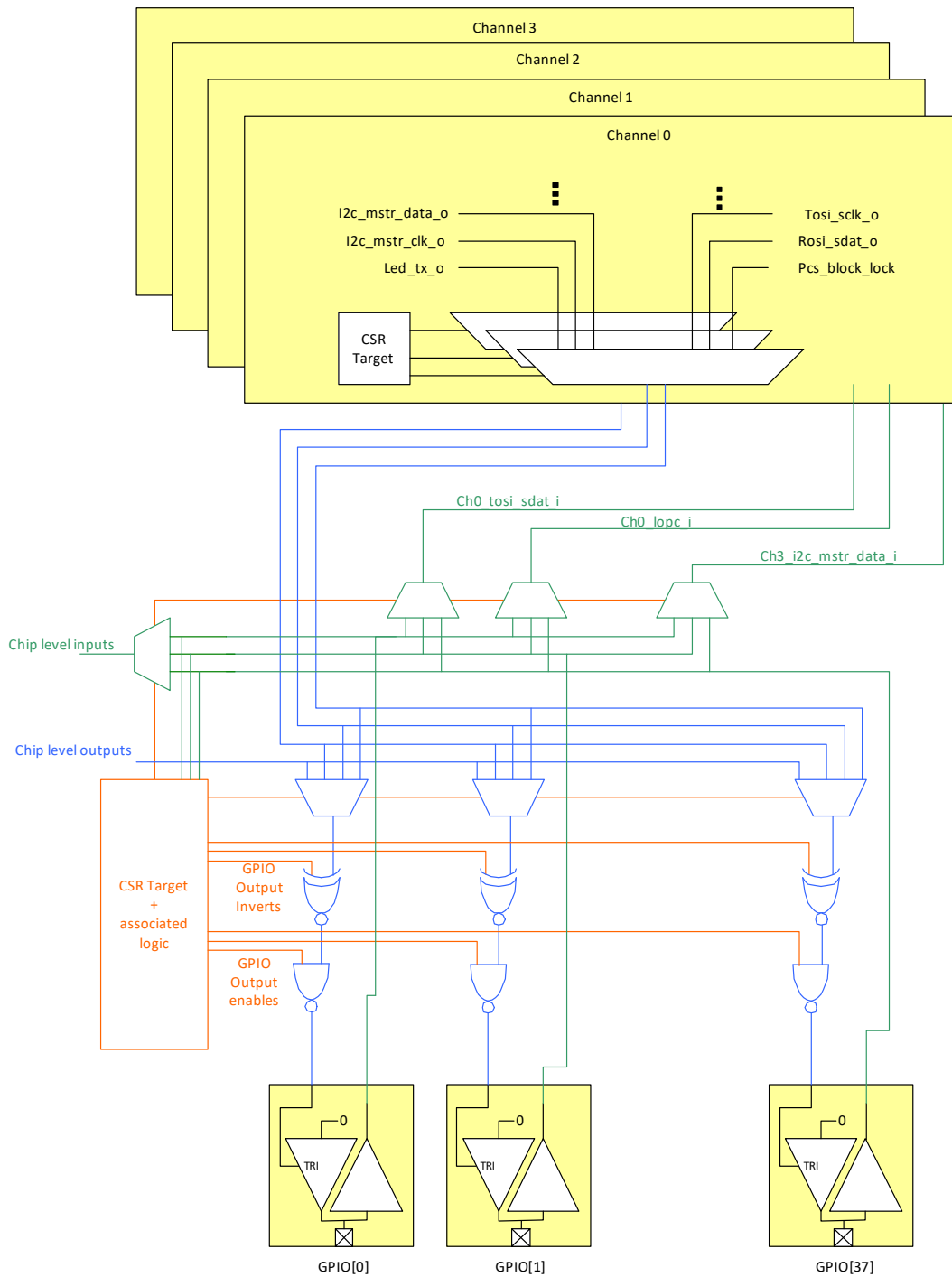
The general purpose I/O (GPIO) functions are organized into 2 groups: per-channel functions and global functions. Per-channel functions include an I2C master (often used for communicating with a module), host and line link status indications, activity LEDs, and WAN interface sublayer (WIS), and ROSI/TOSI interface functions. Global functions include interrupt generation logic, an I2C slave interface, and other miscellaneous I/O configuration and control.

The 40 pins associated with the GPIO functionality are configurable; any function can be mapped to any GPIO pin. The only restriction is that for each channel, only 8 of the per-channel GPIO output functions may be used at a time (note that the ROSI/TOSI interface requires 5 outputs and 1 input).

All GPIOs are configured for open-drain operation, so if used as an output, they must have pull-up resistors connected.

The following block diagram shows the GPIO scheme.

**Figure 81 • GPIO Block Diagram**



The following table shows the recommended GPIO pin configurations. Contact Microsemi applications support for recommendations on alternative GPIO configurations.

**Table 45 • Recommended GPIO Configurations**

GPIO	Configuration
GPIO_0	CH0_RATESEL0

**Table 45 • Recommended GPIO Configurations (continued)**

<b>GPIO</b>	<b>Configuration</b>
GPIO_1	CH0_MOD_ABS
GPIO_2	CH0_I2C_MST_SCL
GPIO_3	CH0_I2C_MST_SDA
GPIO_4	CH0_TX_DIS
GPIO_5	CH0_TX_FAULT
GPIO_6	CH0_RXLOS <sup>(1)</sup>
GPIO_7	CH0_LINK_UP
GPIO_8	CH1_RATESEL0
GPIO_9	CH1_MOD_ABS
GPIO_10	CH1_I2C_MST_SCL
GPIO_11	CH1_I2C_MST_SDA
GPIO_12	CH1_TX_DIS
GPIO_13	CH1_TX_FAULT
GPIO_14	CH1_RXLOS
GPIO_15	CH1_LINK_UP
GPIO_16	CH2_RATESEL0
GPIO_17	CH2_MOD_ABS
GPIO_18	CH2_I2C_MST_SCL
GPIO_19	CH2_I2C_MST_SDA
GPIO_20	CH2_TX_DIS
GPIO_21	CH2_TX_FAULT
GPIO_22	CH2_RXLOS
GPIO_23	CH2_LINK_UP
GPIO_24	CH3_RATESEL0
GPIO_25	CH3_MOD_ABS
GPIO_26	CH3_I2C_MST_SCL
GPIO_27	CH3_I2C_MST_SDA
GPIO_28	CH3_TX_DIS
GPIO_29	CH3_TX_FAULT
GPIO_30	CH3_RXLOS
GPIO_31	CH3_LINK_UP
GPIO_32	I2C_SLAVE_SDA
GPIO_33	I2C_SLAVE_SCL
GPIO_34	INTR_A
GPIO_35	INTR_B
GPIO_36	CH0_ACTIVITY
GPIO_37	CH1_ACTIVITY
GPIO_38	CH2_ACTIVITY

**Table 45 • Recommended GPIO Configurations (continued)**

GPIO	Configuration
GPIO_39	CH3_ACTIVITY

- Optional wire-or between RXLOS and LINK\_UP

### 3.14.7.1 Inputs

The input state of the GPIO pins can be routed to any of GPIO input functions in each channel, or to any of the global functions. The multiplexors for each of these functions may select any of the GPIOs, or a “0” or “1” to force the function input to a known state.

By default, GPIO32 and GPIO33 are routed to the I2C slave input data and input clock, respectively.

The current state of each GPIO input can be read, and a sticky bit corresponding to each GPIO input indicates if it has changed state. These may be useful for monitoring module status signals such as MOD\_ABS, TWS\_INTERRUPT, and so on.

### 3.14.7.2 Outputs

A set of eight multiplexors in each channel select the per-channel output functions that are routed out to each of the eight per-channel virtual GPIO outputs. These multiplexors are configured using the configuration/status module in the channel. A second level of multiplexing occurs at the GPIO pin itself, where the individual per-channel virtual outputs, as well as chip level output functions, are associated with a particular GPIO output.

There are additional chip-level functions (such as interrupts) that may also be assigned to a GPIO pin. Each output may also be configured to drive a static low or static high.

All outputs are initially disabled except for GPIO32, which is by default assigned as the I2C slave output data.

### 3.14.7.3 Interrupts and Interrupt Masking

The VSC8257-01 has configurable interrupt generators that can be used to flag error or alarm conditions which can, in turn, be used to prompt external controllers to take action upon certain events. Multiple blocks in a given channel contain these maskable interrupts (including line and host PMAs, line and host PCSs, the WIS, and rate-adaptation FIFOs). Each of the channel interrupt sources is routed to 2 interrupt generators per channel. For each per-channel interrupt generator, the sources that contribute to that interrupt are independently maskable using channel interrupt enables. Also, the status of each masked interrupt source is always readable in the channel so that the source of the interrupt can be determined quickly.

At the chip level, each ip1588 instance generates 2 interrupts and 2 time stamp FIFO status indicators. There is also an interrupt produced by the cross-connect. Finally, any GPIO input can be configured to produce an interrupt upon state change.

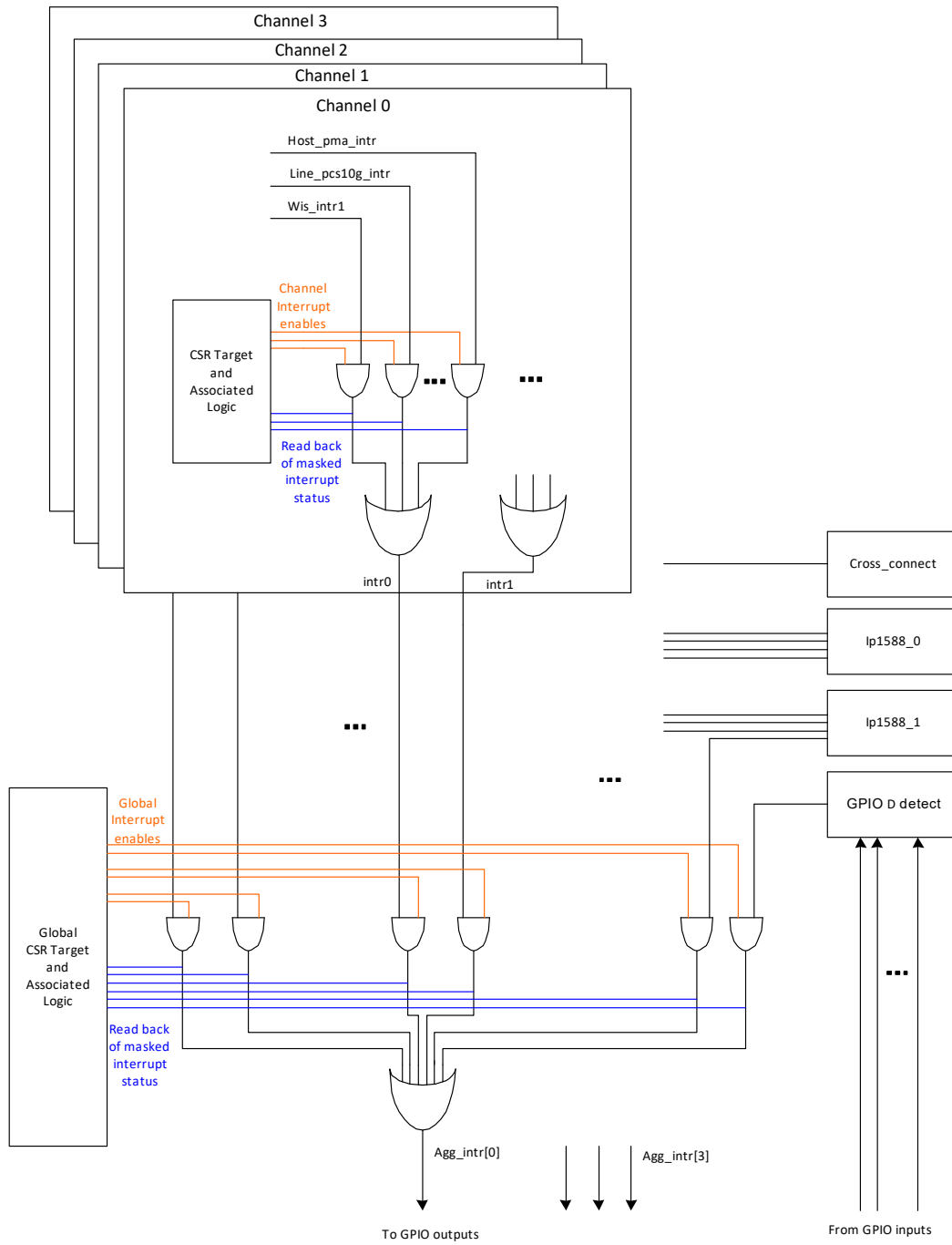
All the chip-level interrupts, as well as the 8 channel interrupts, are routed to each of 4 aggregate interrupt generators. The source of the interrupts for each aggregator is independently maskable (see note) using global interrupt enables, and the masked status of each interrupt is readable in the global target for quick determination of the source of the interrupt.

**Note:** While there are four interrupt generators, in the case of GPIO input state change detection, there is only one mask shared among all four interrupt aggregators.

Any GPIO may be configured to output the state of any of the 4 interrupts.

The following figure shows an overview of the interrupt blocks.

Figure 82 • Interrupt Scheme



## 4 Registers

---

Information about the registers for this product is available in the attached Adobe Acrobat file. To view or print the information, double-click the attachment icon.

## 5 Electrical Specifications

This section provides the DC characteristics, AC characteristics, recommended operating conditions, and stress ratings for the VSC8257-01 device.

### 5.1 DC Characteristics

This section contains the DC specifications for the VSC8257-01 device.

#### 5.1.1 Low-Speed Inputs and Outputs

The following tables list the DC specifications for the LVTTTL inputs and outputs for the VSC8257-01 device. LVTTTL inputs are 3.3 V tolerant when VDDTTL is 2.5 V.

**Table 46 • LVTTTL Input and Push/Pull Output DC Characteristics**

Parameter	Symbol	Minimum	Maximum	Unit	Condition
Output high voltage, LVTTTL	$V_{OH\_TTL}$	1.8	$V_{DDTTL}$	V	$V_{DDTTL} = 2.5\text{ V}$ and $I_{OH} = -4\text{ mA}$
Output low voltage, LVTTTL	$V_{OL}$		0.5	V	$V_{DDTTL}/V_{DDMDIO} = 2.5\text{ V}$ and $I_{OL} = 4\text{ mA}$
Input high voltage	$V_{IH}$	1.7	$V_{DDTTL}$	V	$V_{DDTTL}/V_{DDMDIO} = 2.5\text{ V}$
Input low voltage	$V_{IL}$		0.8	V	$V_{DDTTL}/V_{DDMDIO} = 2.5\text{ V}$
Input high current	$I_{IH}$		500	$\mu\text{A}$	$V_{IH} = V_{DDTTL}/V_{DDMDIO}$
Input low current	$I_{IL}$	-100		$\mu\text{A}$	$V_{IL} = 0\text{ V}$

**Table 47 • LVTTLOD Input and Open-Drain Output DC Characteristics**

Parameter	Symbol	Minimum	Maximum	Unit	Condition
Output high voltage, open drain	$V_{OH\_OD}$	See note <sup>1</sup>	$V_{DDTTL}$	V	$V_{DDTTL}/V_{DDMDIO} = 2.5\text{ V}$ and $I_{OH} = -4\text{ mA}$
Input high leakage current, open drain	$I_{OZH}$		100	$\mu\text{A}$	
Output low voltage (open drain)	$V_{OL}$		0.5	V	$V_{DDTTL}/V_{DDMDIO} = 2.5\text{ V}$ and $I_{OL} = 4\text{ mA}$
Input high voltage	$V_{IH}$	1.7	$V_{DDTTL}$	V	$V_{DDTTL}/V_{DDMDIO} = 2.5\text{ V}$
Input low voltage	$V_{IL}$		0.8	V	$V_{DDTTL}/V_{DDMDIO} = 2.5\text{ V}$
Input high current	$I_{IH}$		500	$\mu\text{A}$	$V_{IH} = V_{DDTTL}/V_{DDMDIO}$
Input low current	$I_{IL}$	-100		$\mu\text{A}$	$V_{IL} = 0\text{ V}$

1. Determined by the loading current of the other devices connecting to this pin, the  $I_{OZH}$  current of this pin, and the value of the pull-up resistor used.



## 5.1.2 Reference Clock

The following table lists the DC specifications for the reference clock for the VSC8257-01 device.

**Table 48 • Reference Clock DC Characteristics**

Parameter	Symbol	Minimum	Maximum	Unit	Condition
HREFCK/LREFCK differential input swing, high <sup>1</sup>	$\Delta V_{I\_DIFF\_HIGH}$	1100	2400	mV <sub>P-P</sub>	LVPECL reference clock input
HREFCK/LREFCK differential input swing, low <sup>1</sup>	$\Delta V_{I\_DIFF\_LOW}$	200	1200	mV <sub>P-P</sub>	CML reference clock input
SREFCK differential input swing	$\Delta V_{I\_DIFF}$	200	2400	mV <sub>P-P</sub>	

1. An API call is used to set the input swing to be high or low.

## 5.2 AC Characteristics

This section contains the AC specifications for the VSC8257-01 device. The specifications apply to all channels. All SFI inputs and outputs should be AC-coupled, and should work in differential.

### 5.2.1 Receiver Specifications

The specifications in the following table correspond to line-side 10G receiver input, SFI point D. Point D assumes that the input is from a compliant point C output and a compliant SFI or XFI channel according to the SFP+ standard (SFF-8431) or the XFP multisource agreement (INF-8077i). The measurement is done with a 9 dB channel loss unless stated otherwise.

The SFI and XFI input of the 10G receiver are tested and characterized to support the ITU-T recommendation G.709 (OTN) OTU2, OTU1e, and OTU2e line rates (10.709 Gbps, 11.049 Gbps, and 11.095 Gbps) with a channel loss of 6.5 dB or less.

**Note:** OTN rates and 10/100M rates under SGMII are only supported in repeater mode. For additional details regarding OTN line rates and the corresponding electrical characteristics, contact your Microsemi representative.

The CDR lock time at the 10G input to the PMA is 5  $\mu$ s, maximum.

**Table 49 • Host- and Line-Side 10G Receiver Input (SFI Point D)**

Parameter	Symbol	Minimum	Typical	Maximum	Unit	Condition
Input data rate		9.95328 – 100 ppm	10.3125	10.3125 + 100 ppm	Gbps	10 Gbps LAN/WAN
Input linear mode differential input data swing	$\Delta VRXIN_{LINEAR}$	180		600	mV	Voltage modulation amplitude (VMA)
Input limiting mode differential input data swing	$\Delta VRXIN_{LIMITING}$	300		850	mV	Measured peak-to-peak
Input AC common-mode voltage	$V_{CM}$			15	mV <sub>RMS</sub>	
Differential return loss	$RL_{SDD11}$			–12	dB	0.01 GHz to 2.8 GHz
Differential return loss	$RL_{SDD11}$			–8.15 + 13.33 x $\log_{10}(f/5.5 \text{ GHz})$	dB	2.8 GHz to 11.1 GHz

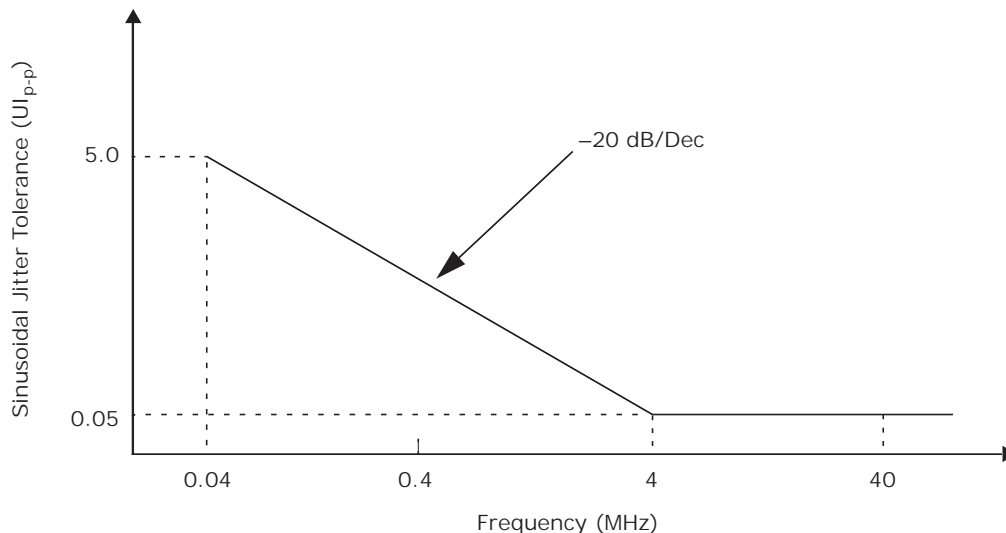
**Table 49 • Host- and Line-Side 10G Receiver Input (SFI Point D) (continued)**

Parameter	Symbol	Minimum	Typical	Maximum	Unit	Condition
Reflected differential to common-mode conversion	$RL_{SCD11}$			-15	dB	0.01 GHz to 11.1 GHz

**Table 50 • Host- and Line-Side 10G Receiver Input (SFI Point C")**

Parameter	Symbol	Minimum	Typical	Maximum	Unit	Condition
99% jitter	$99\%_{JIT\_p-p}$			0.42	UI	
Pulse width shrinkage jitter	$DDPWS_{JIT\_p-p}$			0.3	UI	
Total jitter tolerance	$TOL_{JIT\_P-P}$			0.70	UI	
Eye mask X1	X1			0.35	UI	
Eye mask Y1	Y1	150			mV	
Eye mask Y2	Y2			425	mV	
Waveform distortion penalty	WDPC			9.3	dBe	BER 1E-12. This parameter of DAC is measured with 7dB SFI channel loss.
Voltage modulation amplitude	VMA	180			mV	BER 1E-12. This parameter of DAC is measured with 7dB SFI channel loss.
Optical sensitivity (ROP), back-to-back, 10.3 Gbps	$S_{B2B}$			-24	dBm	BER 1E-12, PRBS31 and 10 GbE frame. 5.76 dB SFI channel loss.
Optical sensitivity (ROP), with fiber plant, 10.3 Gbps	$S_{FIBER}$			-21	dBm	95 km single-mode fiber, BER 1E-12, PRBS31 and 10 GbE frame. 5.76 dB SFI channel loss.
Chromatic dispersion penalty	$F_{CDP}$			3	dB	1600 ps/nm. 5.76 dB SFI channel loss.
OSNR vs BER with fiber plant, 10.7 Gbps	$OSNR_{FEC}$	16			dB	95 km single-mode fiber, BER 7E-4, 5.76 dB SFI channel loss.

The following illustration shows the sinusoidal jitter tolerance for the SFI datacom.

**Figure 83 • SFI Datacom Sinusoidal Jitter Tolerance**

The following table lists the 10G input jitter specifications for the VSC8257-01 device.

**Table 51 • Host- and Line-Side SONET 10G Input Jitter**

Parameter	Symbol	Minimum	Typical	Maximum	Unit	Condition
Input data rate, 10 Gbps WAN		9.95328 – 100 ppm	9.95328	9.95328 + 100 ppm	Gbps	
Sinusoidal jitter tolerance, SJ <sub>T</sub> 9.95 Gbps		2x jitter mask				GR-253 according to SONET OC-192 standard

The following table lists the line-side 1.25 Gbps SFI input specifications for the VSC8257-01 device.

**Table 52 • Host- and Line-Side 1.25 Gbps SFI Input**

Parameter	Symbol	Minimum	Typical	Maximum	Unit	Condition
Input data rate, 1.25 Gbps		1.25 – 100 ppm	1.25	1.25 + 100 ppm	Gbps	1.25 Gbps mode
Differential input return loss	RL <sub>SDD11</sub>			–10	dB	50 MHz to 625 MHz
Differential input return loss	RL <sub>SDD11</sub>			–10 + 10 x log (f/625 MHz)	dB	625 MHz to 1250 MHz
Total jitter tolerance	TJ <sub>T</sub>			0.749	UI	Jitter above 637 kHz (IEEE 802.3 clause 38.5)
Deterministic jitter	DJ			0.462	UI <sub>p-p</sub>	Jitter above 637 kHz (IEEE 802.3 clause 38.5)
Eye mask Y1	Y1	125			mV	
Eye mask Y2	Y2			600	mV	

## 5.2.2 Transmitter Specifications

This section includes the transmitter specifications.

The specifications in the following table correspond to line-side 10G transmitter output, SFI point B. Point B is after a standard-compliant SFI or XFI channel, as defined in the SFP+ standard (SFF-8431) or the XFP multisource agreement (INF-8077i). The measurement is done with a 9 dB channel loss unless stated otherwise.

The SFI and XFI output of the 10G transmitter are tested and characterized to support ITU-T recommendation G.709 (OTN) OTU2, OTU1e, and OTU2e line rates (10.709 Gbps, 11.049 Gbps, and 11.095 Gbps) with a channel loss of 6.5 dB or less.

**Note:** OTN rates and 10/100M rates under SGMII are only supported in repeater mode. For additional details regarding OTN line rates and the corresponding electrical characteristics, contact your Microsemi representative.

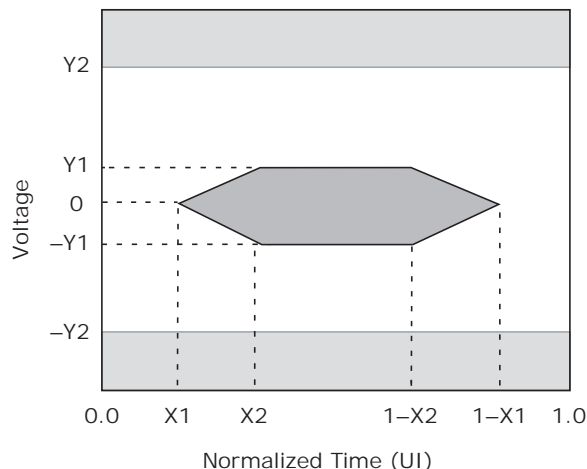
**Table 53 • Host- and Line-Side 10G Transmitter Output (SFI Point A)**

Parameter	Symbol	Minimum	Maximum	Unit	Condition
Termination mismatch	$\Delta Z_M$		5	%	
Differential return loss	SDD22		-12	dB	0.01 GHz to 2.8 GHz
Differential return loss	SDD22		-8.15 + 13.33 x $\log_{10}(f/5.5$ GHz)	dB	2.8 GHz to 11.1 GHz
Common-mode return loss	SCC22		-9	dB	0.01 GHz to 4.74 GHz
Common-mode return loss	SCC22		-8.15 + 13.33 x $\log_{10}(f/5.5$ GHz)	dB	4.74 GHz to 11.1 GHz

**Table 54 • Host- and Line-Side 10G Transmitter Output (SFI Point B)**

Parameter	Symbol	Minimum	Maximum	Unit	Condition
AC common-mode voltage	$V_{OCM\_AC}$		15	mV <sub>RMS</sub>	
Total jitter	TJ		0.28	UI	
Data-dependant jitter	DDJ		0.1	UI	
Pulse shrinkage jitter	DDPWS		0.055	UI	
Uncorrelated jitter	UJ		0.023	UI <sub>RMS</sub>	
Eye mask X1	X1		0.12	UI	
Eye mask X2	X2		0.33	UI	
Eye mask Y1	Y1	95		mV	Tested at 7 dB SFI channel loss.
Eye mask Y2	Y2		350	mV	

The following illustration shows the compliance mask associated with the Tx SFI transmit differential output.

**Figure 84 • SFI Transmit Differential Output Compliance Mask**

The following table shows the transmit path output specifications for SFI point B. These DAC parameters are measured with 7 dB SFI channel loss.

**Table 55 • Transmitter SFP+ Direct Attach Copper Output AC Characteristics**

Parameter	Symbol	Minimum	Maximum	Unit	Condition
SFP+ direct attach copper voltage modulation amplitude, peak-to-peak	$V_{MA}$	300		mV	See SFF-8431 section D.7.
SFP+ direct attach copper transmitter $Q_{SQ}$	$Q_{SQ}$	63.1			See SFF-8431 section D.8.
SFP+ direct attach copper output AC common-mode voltage			12	mV (RMS)	See SFF-8431 section D.15.
SFP+ direct attach copper output TWDPc	TWDPc		10.7	dB	Electrical output measured using SFF-8431 Appendix G, including copper direct attach stressor.

The following table shows that the 10 Gbps transmitter operating in 10GBASE-KR mode complies with IEEE 802.3 clause 72.7.

**Table 56 • 10 Gbps Transmitter 10GBASE-KR AC Characteristics**

Parameter	Symbol	Minimum	Maximum	Unit	Condition
Signalling speed	$T_{BAUD}$	10.3125 – 100 ppm	10.3125 + 100 ppm	Gbps	
Differential output return loss	$RLO_{SDD22}$		–9 –9 + 12 x log (f/2.5 GHz)	dB	50 MHz to 2.5 GHz 2.5 GHz to 7.5 GHz $R_L = 100 \Omega \pm 1\%$
Common mode return loss	$RLO_{CM}$		–6 –6 + 12 x log (f/2.5 GHz)	dB	50 MHz to 2.5 GHz 2.5 GHz to 7.5 GHz $R_L = 100 \Omega \pm 1\%$
Transition time	$T_R, T_F$	24	47	ps	20% to 80%

**Table 56 • 10 Gbps Transmitter 10GBASE-KR AC Characteristics (continued)**

Parameter	Symbol	Minimum	Maximum	Unit	Condition
Random jitter	RJ		0.16	UI	BER 1E–12, 0.151 UI for junction temperature $\leq 100$ °C
Deterministic jitter	DJ		0.15	UI	
Duty cycle distortion (part of DJ)	DCD		0.035	UI	
Total jitter	TJ		0.28	UI	

The following table shows the transmit path optical jitter specifications for point A, measured using COTS SFP-10G module.

**Table 57 • Host- and Line-Side Optical 10G Output Jitter**

Parameter	Symbol	Maximum	Unit	Condition
Total jitter, 20 kHz to 80 MHz	TJ	180	mUI <sub>P-P</sub>	60 second gating time
Total jitter, 4 MHz to 80 MHz	TJ	100	mUI <sub>P-P</sub>	60 second gating time

The following table lists the line-side 1.25 Gbps SFI output specifications for the VSC8257-01 device.

**Table 58 • Host- and Line-Side 1.25 Gbps SFI Output**

Parameter	Symbol	Minimum	Maximum	Unit	Condition
Differential output return loss	RLO <sub>SDD22</sub>		–10	dB	50 MHz to 625 MHz
Differential output return loss	RLO <sub>SDD22</sub>		–10 + 10 x log(f/625 MHz)	dB	625 MHz to 1250 MHz
Common mode return loss	RLO <sub>CM</sub>		–6	dB	50 MHz to 625 MHz
Deterministic jitter	DJ		0.1	UI	Measured according to IEEE 802.3 clause 38.5
Total jitter	TJ		0.24	UI	Measured according to IEEE 802.3 clause 38.5
Eye mask Y1	Y1	150		mV	SFF-8431 1G specification
Eye mask Y2	Y2	500		mV	SFF-8431 1G specification

### 5.2.3 Timing and Reference Clock

The following table lists the reference clock specifications (LREFCK, SREFCK, and HREFCK, and CLK1588) for the VSC8257-01 device.

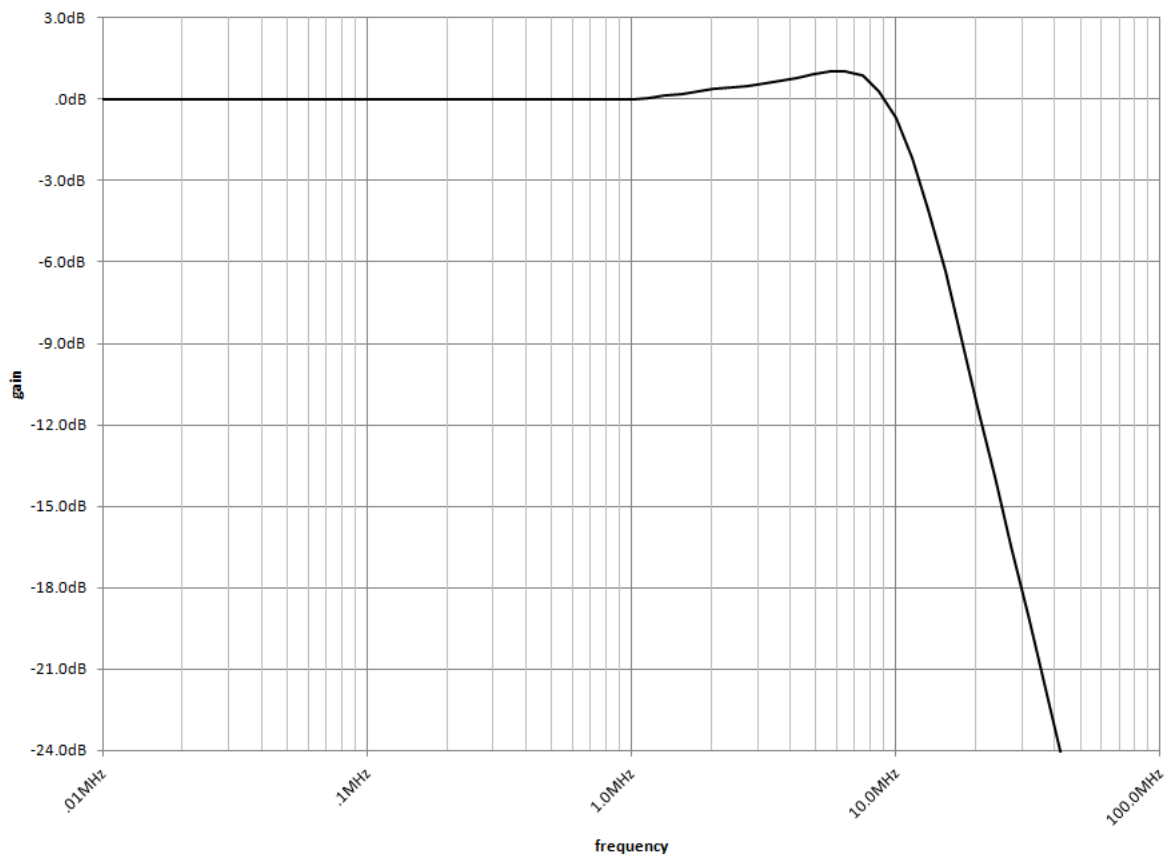
**Table 59 • Reference Clock AC Characteristics**

Parameter	Symbol	Minimum	Typical	Maximum	Unit	Condition
Reference clock frequency	$f_{REFCLK}$	125		156.25	MHz	
Reference clock frequency accuracy	$f_R$	– 100 ppm		100 ppm	MHz	

**Table 59 • Reference Clock AC Characteristics (continued)**

Parameter	Symbol	Minimum	Typical	Maximum	Unit	Condition
Rise time and fall time	$t_R, t_F$			0.4	ns	Within $\pm 200$ mV relative to $V_{DD} \times 2/3$
Reference clock duty cycle	DC	40		60	%	
Jitter tolerance for LREFCLK and HREFCLK	$JT_{L\_REF/H\_REF}$		0.7		ps	For 2 KHz to 20 MHz
Jitter tolerance for CLK1588	$JT_{CLK\_1588}$			100	ps	
Frequency for CLK1588	$f_{CLK\_1588}$		125	250	MHz	
Duty cycle for CLK1588	$DC_{CLK\_1588}$	40	50	60	%	

The following illustration shows the worst-case clock jitter transfer characteristic for the LREFCK input.

**Figure 85 • LREFCK/HREFCLK to Data Output Jitter Transfer**

## 5.2.4 Two-Wire Serial (Slave) Interface

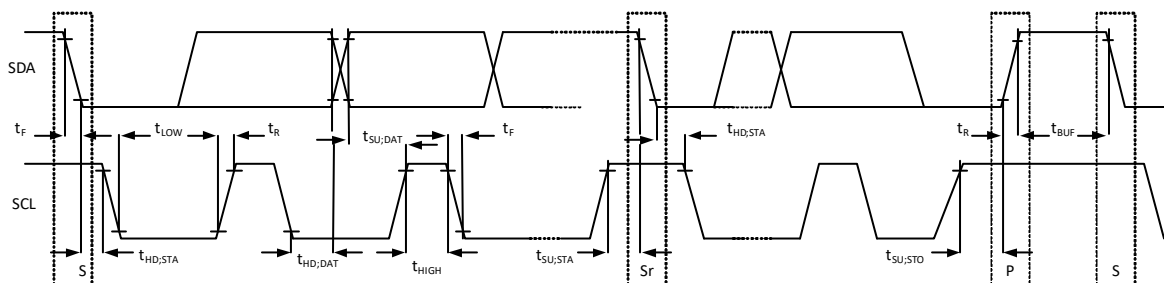
This section contains information about the AC specifications for the two-wire serial slave interface for the VSC8257-01 device.

**Table 60 • Two-Wire Serial Interface AC Characteristics**

Parameter	Symbol	Standard		Fast Mode		Unit
		Minimum	Maximum	Minimum	Maximum	
Serial clock frequency	$f_{SCL}$		100		400	kHz
Hold time START condition after this period, the first clock pulse is generated	$t_{HD:STA}$	4.0		0.6		$\mu$ s
Low period of SCL	$t_{LOW}$	4.7		1.3		$\mu$ s
High period of SCL	$t_{HIGH}$	4.0		0.6		$\mu$ s
Data hold time	$t_{HD:DAT}$	0	3.45	0	0.9	$\mu$ s
Data setup time	$t_{SU:DAT}$	250		100		ns
Rise time for SDA and SCL	$t_R$		1000		300	ns
Fall time for SDA and SCL	$t_F$		300		300	ns
Setup time for STOP condition	$t_{SU:STO}$	4.0		0.6		$\mu$ s
Bus free time between a STOP and START	$t_{BUF}$	4.7		1.3		$\mu$ s
Capacitive load for SCL and SDA bus line	$C_B$		400		330	pF
External pull-up resistor <sup>1</sup>	$R_P$	900	$8 \times 10^{-7}/C_B$	900	$3 \times 10^{-7}/C_B$	$\Omega$

1. Minimum value is determined from  $I_{OL}$  and internal reliability requirements. Maximum value is determined by load capacitance. Microsemi recommends 10 k $\Omega$  for typical applications in which capacitance loads are below the specified minimums.

**Figure 86 • Two-Wire Serial Interface Timing**



S = START, P = STOP, and Sr = repeated START.



## 5.2.5 MDIO Interface

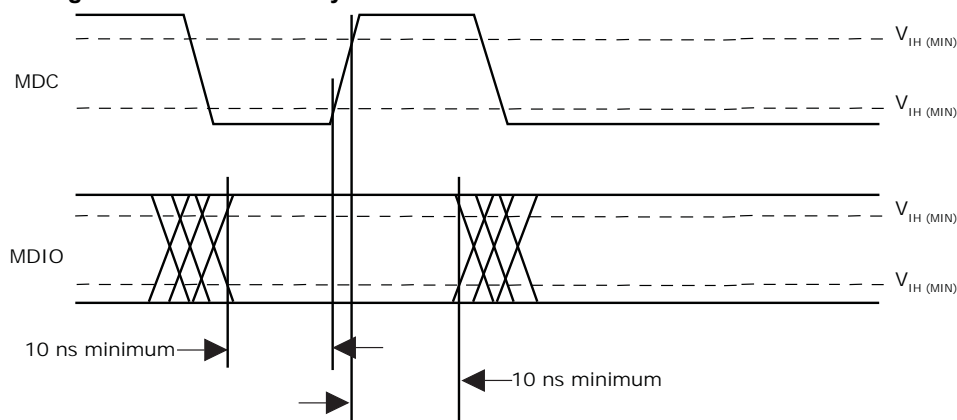
This section contains information about the AC specifications for the MDIO interface for the VSC8257-01 device.

**Table 61 • MDIO Interface AC Characteristics**

Parameter	Symbol	Minimum	Maximum	Unit
MDIO data hold time	$t_{\text{HOLD}}$	10		ns
MDIO data setup time	$t_{\text{SU}}$	10		ns
Delay from MDC rising edge to MDIO data change	$t_{\text{DELAY}}$		300	ns
MDC clock rate	$f$		2.5	MHz

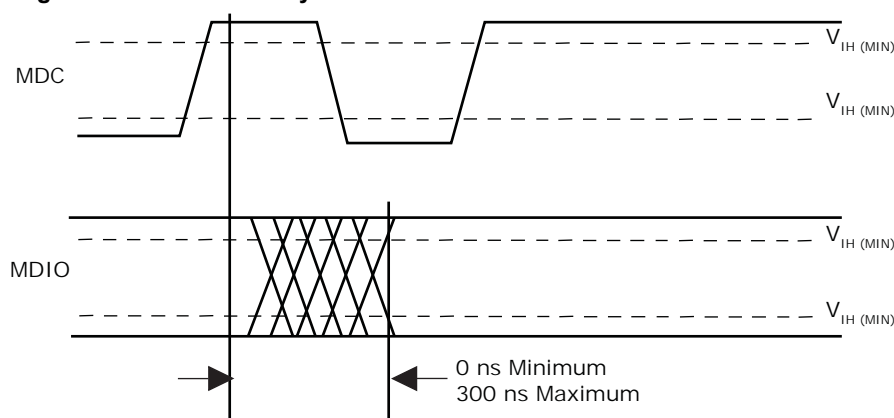
The following illustration shows the timing with the MDIO sourced by STA.

**Figure 87 • Timing with MDIO Sourced by STA**



The following illustration shows the timing with the MDIO sourced by MMD.

**Figure 88 • Timing with MDIO Sourced by MMD**



The following table lists the clock output specifications the device.

**Table 62 • Clock Output AC Characteristics**

Parameter	Symbol	Minimum	Maximum	Unit	Condition
CKOUT[0:3]N/P jitter generation	$JG_{\text{C64}}$		15	$\text{ps}_{\text{RMS}}$	10 kHz to 10 MHz
CKOUT[0:3]N/P differential output swing	$\Delta V$	650	900	$\text{mV}_{\text{P-P}}$	

## 5.2.6 Synchronous Time-of-Day Load/Save Timing

When the 1588 Load/Save strobe pin, LS, is applied to the device synchronous to CLK1588P/N, the setup and hold (minimum) times shown in the following table must be satisfied.

**Table 63 • Load/Save Setup and Hold Timing AC Characteristics**

Parameter	Symbol	Minimum	Unit
1588 LOAD/SAVE setup time	$t_{\text{SETUP}}$	1.0	ns
1588 LOAD/SAVE hold time	$t_{\text{HOLD}}$	0.7	ns

The following illustration shows the LOAD/SAVE AC timing.

**Figure 89 • Load/Save AC Timing**



## 5.2.7 SPI Slave Interface

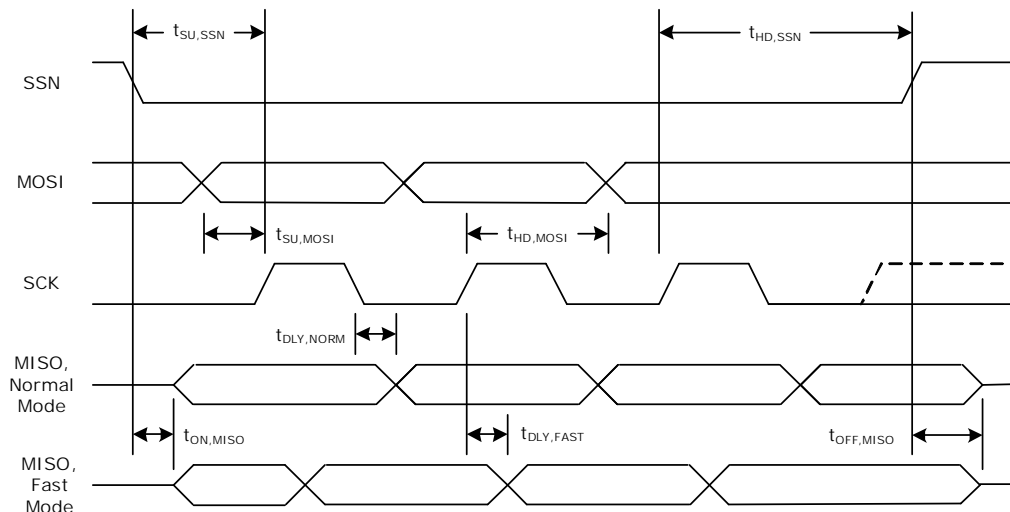
This section contains information about the AC specifications for the four-pin SPI slave interface used to read and write registers. The maximum clock rate is 30 MHz, and it is configurable.

**Table 64 • SPI Slave Interface AC Characteristics**

Parameter	Symbol	Minimum	Maximum	Unit	Condition
MOSI data setup time	$t_{\text{SU, MOSI}}$	10		ns	
MOSI data hold time	$t_{\text{HD, MOSI}}$	10		ns	
SSN data setup time	$t_{\text{SU, SSN}}$	15		ns	SSN transition low to enable interface
SSN data hold time	$t_{\text{HD, SSN}}$	SCK clock period + 15		ns	SSN transition high to enable interface
SSN transition low to MISO valid	$t_{\text{ON, MISO}}$	2		ns	
SSN transition high to MISO high impedance	$t_{\text{OFF, MISO}}$		10	ns	
Falling SCK to valid MISO data, normal mode	$t_{\text{DLY, NORM}}$	14	30	ns	Maximum capacitance loading of 5 pF
			35	ns	Maximum capacitance loading of 50 pF
			36	ns	Maximum capacitance loading of 100 pF
Rising SCK to valid MISO data, fast mode	$t_{\text{DLY, FAST}}$	14	30	ns	Maximum capacitance loading of 5 pF
			35	ns	Maximum capacitance loading of 50 pF
			36	ns	Maximum capacitance loading of 100 pF

The following illustration shows the SPI interface timing.

**Figure 90 • SPI Interface Timing**



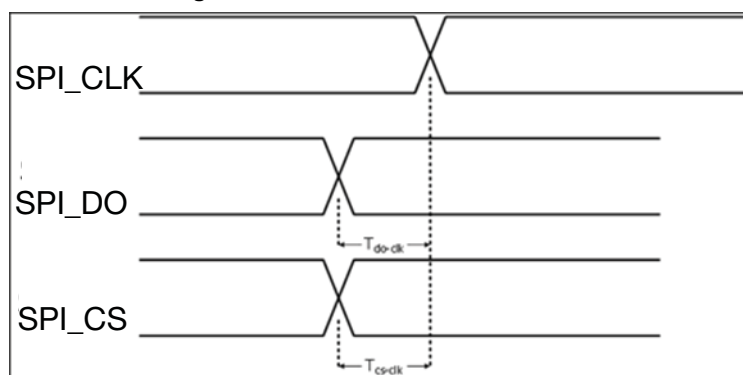
The following table lists the AC characteristics for the 3-pin push-out SPI.

**Table 65 • 3-Pin Push-Out SPI AC Characteristics**

Parameter	Symbol	Minimum	Maximum	Unit
SPI_DO to SPI_CLK delay	$t_{DO, CLK}$	-2	5	ns
SPI_CS to SPI_CLK delay	$t_{CS, CLK}$	-2	5	ns

The following illustration shows the 3-pin push-out SPI timing.

**Figure 91 • 3-Pin Push-Out SPI Timing**



## 5.3 Operating Conditions

To ensure that the control pins remain set to the desired configured state when the device is powered up, perform a reset using the reset pin after power-up and after the control pins are steady for 1 ms.

It is recommended to have all the 1 V power rails move together.

**Table 66 • Recommended Operating Conditions**

Parameter	Symbol	Minimum	Typical	Maximum	Unit	Condition
1.0 V power supply voltage	$V_{DDL R}$	0.94575	0.975	1.00425	V	Power rail at 0.975 V $\pm$ 3%
	$V_{DDL}$	0.97	1.0	1.03	V	Power rail at 1.0 V $\pm$ 3%
	$V_{DDA H}$					
	$V_{DDA L}$					
1.2 V power supply voltage	$V_{DDH S L}$	1.14		1.26	V	$\pm$ 5%
	$V_{DDH S H}$					
2.5 V TTL I/O power supply voltage	$V_{DDT T L}$	2.375		2.625	V	$\pm$ 5%
	$V_{DDM D I O}$					
Power consumption	$P_{DD}$			7	W	$V_{DDL} = V_{DDL R} = V_{DDA H} = V_{DDA L} = 1.0042$ V, maximum <sup>1</sup> $V_{DDH S H} = V_{DDH S L} = 1.26$ V $V_{DDT T L} = V_{DDM D I O} = 2.625$ V
Clock output power	$P_{DD\_CLK}$	0		40	mW	Per clock output
SREFCK input power	$P_{DD\_SREFCK}$	0		60	mW	
Operating temperature <sup>2</sup>	T	-40		110	$^{\circ}$ C	

1. Device can be run at 1 V +3% with a worst case power of 7.8 W.

2. Minimum specification is ambient temperature, and the maximum is junction temperature.

## 5.4 Stress Ratings

This section contains the stress ratings for the device.

**Warning** Stresses listed in the following table may be applied to devices one at a time without causing permanent damage. Functionality at or exceeding the values listed is not implied. Exposure to these values for extended periods may affect device reliability.

**Table 67 • Stress Ratings**

Parameter	Symbol	Minimum	Maximum	Unit
1.0 V power supply voltage, potential to ground	$V_{DDA H}$ $V_{DDA L}$ $V_{DDL}$ $V_{DDL R}$	-0.3	1.1	V
1.2 V power supply voltage, potential to ground	$V_{DDH S L}$ $V_{DDH S H}$	-0.3	1.32	V
2.5 V TTL I/O power supply voltage	$V_{DDT T L}$ $V_{DDM D I O}$	-0.3	2.75	V
Storage temperature	$T_S$	-55	125	$^{\circ}$ C
Electrostatic discharge voltage, charged device model	$V_{ESD\_CDM}$	-250	250	V
Electrostatic discharge voltage, human body model, CLK1588N and CLK1588P pins	$V_{ESD\_HBM}$	-1750	1750	V
Electrostatic discharge voltage, human body model, all pins except the CLK1588N and CLK1588P pins	$V_{ESD\_HBM}$	See note <sup>1</sup>		V

1. This device has completed all required testing as specified in the JEDEC standard JESD22-A114, *Electrostatic Discharge (ESD) Sensitivity Testing Human Body Model (HBM)*, and complies with a Class 2 rating. The definition of Class 2 is any part that passes an ESD pulse of 2000 V, but fails an ESD pulse of 4000 V.

**Warning** This device can be damaged by electrostatic discharge (ESD) voltage. Microsemi recommends that all integrated circuits be handled with appropriate precautions. Failure to observe proper handling and installation procedures may adversely affect reliability of the device.

## 6 Pin Descriptions

The VSC8257-01 device has 256 pins, which are described in this section.

The pin information is also provided as an attached Microsoft Excel file, so that you can copy it electronically. In Adobe Reader, double-click the attachment icon.

### 6.1 Pin Diagram

The following illustration shows the pin diagram for the device.

Figure 92 • Pin Diagram

	1	2	3	4	5	6	7	8	9	10	11	12	13	14	15	16
A	GND	GND	GND	SSN	TRSTB	SCK	TDO	TDI	RESETN	CLK1588P	CLK1588N	NC	CKOUT0P	GND	GND	GND
B	RXOUT0N	RXOUT0P	GND	MOSI	TMS	MISO	TCK	GPIO_4	GPIO_5	MODE0	MODE1	NC	CKOUT0N	GND	RXIN0P	RXIN0N
C	GND	GND	GND	TDION	TDIOP	LS	PPS_RI	PPS	SPL_CLK_01	SPL_DO_01	SPL_CS_01	NC	GND	GND	GND	GND
D	TXIN0N	TXIN0P	GND	GPIO_0	GPIO_1	GPIO_2	GPIO_3	GPIO_6	GPIO_7	GPIO_8	GPIO_9	GPIO_10	CKOUT1P	GND	TXOUT0P	TXOUT0N
E	GND	GND	GND	GPIO_11	GPIO_12	GPIO_13	GPIO_14	GPIO_15	GPIO_16	GPIO_17	GPIO_18	GPIO_19	CKOUT1N	GND	GND	GND
F	RXOUT1N	RXOUT1P	GND	VDDAH	GND	GND	VDDTTL	VDDL	GND	VDDL	VDDAL	GND	GND	GND	RXIN1P	RXIN1N
G	GND	GND	GND	VDDSH	VDDAH	GND	VDDL	VDDL	GND	VDDAL	VDDHSL	GND	CKOUT3P	GND	GND	GND
H	TXIN1N	TXIN1P	GND	VDDSH	VDDAH	GND	VDDL	VDDL	GND	VDDAL	VDDHSL	GND	CKOUT3N	GND	TXOUT1P	TXOUT1N
J	GND	GND	GND	VDDSH	VDDAH	GND	VDDL	VDDL	GND	VDDAL	VDDHSL	GND	GND	GND	GND	GND
K	RXOUT2N	RXOUT2P	GND	VDDSH	VDDAH	GND	VDDL	VDDL	GND	VDDAL	VDDHSL	GND	CKOUT2P	GND	RXIN2P	RXIN2N
L	GND	GND	GND	VDDAH	VDDMDIO	GND	VDDTTL	VDDL	GND	VDDL	VDDAL	GND	CKOUT2N	GND	GND	GND
M	TXIN2N	TXIN2P	GND	GPIO_20	GPIO_21	GPIO_22	GPIO_23	GPIO_24	GPIO_25	GPIO_26	GPIO_27	NC	GND	GND	TXOUT2P	TXOUT2N
N	GND	GND	GND	GPIO_28	GPIO_29	GPIO_30	GPIO_31	GPIO_32	GPIO_33	GPIO_34	GPIO_35	NC	SCKOUTP	GND	GND	GND
P	RXOUT3N	RXOUT3P	GND	NC	GPIO_36	GPIO_37	GPIO_38	GPIO_39	SPL_CLK_23	SPL_DO_23	SPL_CS_23	NC	SCKOUTN	GND	RXIN3P	RXIN3N
R	GND	GND	GND	GND	MDIO	MODE2	HREFCKP	PADDR3	LREFCKP	MODE3	SREFCKP	RCOMP	GND	GND	GND	GND
T	GND	TXIN3N	TXIN3P	GND	MDC	PADDR4	HREFCKN	PADDR2	LREFCKN	NC	SREFCKN	RCOMP	GND	TXOUT3P	TXOUT3N	GND

### 6.2 Pins by Function

This section contains the functional pin descriptions for the VSC8257-01 device.

**Note:** All differential data or clock signals should be AC-coupled. A cap of 0.1  $\mu$ F would be sufficient.

Functional Group	Name	Number	Type	Level	Description
1588	CLK1588N	A11	I	CML	1588 local time counter clock input, complement
1588	CLK1588P	A10	I	CML	1588 local time counter clock input, true
1588	LS	C6	B	LVTTTL	1588 load/save input. Internally pulled low.
1588	PPS	C8	B	LVTTTL	1588 pulse per second (output)
1588	PPS_RI	C7	I	LVTTTL	1588 pulse per second return input signal. Internally pulled low.
1588	SPI_CLK_01	C9	O	LVTTTL	Pushout SPI clock output for 1588 timestamp (channel 0 and channel 1)
1588	SPI_CLK_23	P9	O	LVTTTL	Pushout SPI clock output for 1588 timestamp (channel 2 and channel 3)
1588	SPI_CS_01	C11	O	LVTTTL	Pushout SPI chip select output for 1588 timestamp (channel 0 and channel 1)
1588	SPI_CS_23	P11	O	LVTTTL	Pushout SPI chip select output for 1588 timestamp (channel 2 and channel 3)
1588	SPI_DO_01	C10	O	LVTTTL	Pushout SPI data output for 1588 timestamp (channel 0 and channel 1)
1588	SPI_DO_23	P10	O	LVTTTL	Pushout SPI data output for 1588 timestamp (channel 2 and channel 3)
Clock Signal	CKOUT0N	B13	O	CML	Selectable clock output channel 0, complement
Clock Signal	CKOUT0P	A13	O	CML	Selectable clock output channel 0, true
Clock Signal	CKOUT1N	E13	O	CML	Selectable clock output channel 1, complement
Clock Signal	CKOUT1P	D13	O	CML	Selectable clock output channel 1, true
Clock Signal	CKOUT2N	L13	O	CML	Selectable clock output channel 2, complement
Clock Signal	CKOUT2P	K13	O	CML	Selectable clock output channel 2, true
Clock Signal	CKOUT3N	H13	O	CML	Selectable clock output channel 3, complement

Clock Signal	CKOUT3P	G13	O	CML	Selectable clock output channel 3, true
Clock Signal	HREFCKN	T7	I	CML	Host reference clock input, complement. Must be frequency locked to LREFCKP/N.
Clock Signal	HREFCKP	R7	I	CML	Host reference clock input, true. Must be frequency locked to LREFCKP/N.
Clock Signal	LREFCKN	T9	I	CML	Line reference clock input, complement
Clock Signal	LREFCKP	R9	I	CML	Line reference clock input, true
Clock Signal	SCKOUTN	P13	O	CML	SyncE recovered clock output, complement
Clock Signal	SCKOUTP	N13	O	CML	SyncE recovered clock output, true
Clock Signal	SREFCKN	T11	I	CML	SyncE reference clock input, complement
Clock Signal	SREFCKP	R11	I	CML	SyncE reference clock input, true
JTAG	TCK	B7	I	LVTTTL	Boundary scan, test clock input. Internally pulled high.
JTAG	TDI	A8	I	LVTTTL	Boundary scan, test data input. Internally pulled high.
JTAG	TDO	A7	O	LVTTTL	Boundary scan, test data output.
JTAG	TMS	B5	I	LVTTTL	Boundary scan, test mode select. Internally pulled high.
JTAG	TRSTB	A5	I	LVTTTL	Boundary scan, test reset input. Internally pulled high.
MDIO	MDC	T5	I	LVTTTL	MDIO clock input
MDIO	MDIO	R5	B	LVTTLOD	MDIO data I/O
Miscellaneous	GPIO_0	D4	B	LVTTLOD	General purpose I/O 0
Miscellaneous	GPIO_1	D5	B	LVTTLOD	General purpose I/O 1
Miscellaneous	GPIO_2	D6	B	LVTTLOD	General purpose I/O 2
Miscellaneous	GPIO_3	D7	B	LVTTLOD	General purpose I/O 3
Miscellaneous	GPIO_4	B8	B	LVTTLOD	General purpose I/O 4
Miscellaneous	GPIO_5	B9	B	LVTTLOD	General purpose I/O 5
Miscellaneous	GPIO_6	D8	B	LVTTLOD	General purpose I/O 6
Miscellaneous	GPIO_7	D9	B	LVTTLOD	General purpose I/O 7
Miscellaneous	GPIO_8	D10	B	LVTTLOD	General purpose I/O 8
Miscellaneous	GPIO_9	D11	B	LVTTLOD	General purpose I/O 9
Miscellaneous	GPIO_10	D12	B	LVTTLOD	General purpose I/O 10
Miscellaneous	GPIO_11	E4	B	LVTTLOD	General purpose I/O 11
Miscellaneous	GPIO_12	E5	B	LVTTLOD	General purpose I/O 12
Miscellaneous	GPIO_13	E6	B	LVTTLOD	General purpose I/O 13



Miscellaneous	GPIO_14	E7	B	LVTTL0D	General purpose I/O 14
Miscellaneous	GPIO_15	E8	B	LVTTL0D	General purpose I/O 15
Miscellaneous	GPIO_16	E9	B	LVTTL0D	General purpose I/O 16
Miscellaneous	GPIO_17	E10	B	LVTTL0D	General purpose I/O 17
Miscellaneous	GPIO_18	E11	B	LVTTL0D	General purpose I/O 18
Miscellaneous	GPIO_19	E12	B	LVTTL0D	General purpose I/O 19
Miscellaneous	GPIO_20	M4	B	LVTTL0D	General purpose I/O 20
Miscellaneous	GPIO_21	M5	B	LVTTL0D	General purpose I/O 21
Miscellaneous	GPIO_22	M6	B	LVTTL0D	General purpose I/O 22
Miscellaneous	GPIO_23	M7	B	LVTTL0D	General purpose I/O 23
Miscellaneous	GPIO_24	M8	B	LVTTL0D	General purpose I/O 24
Miscellaneous	GPIO_25	M9	B	LVTTL0D	General purpose I/O 25
Miscellaneous	GPIO_26	M10	B	LVTTL0D	General purpose I/O 26
Miscellaneous	GPIO_27	M11	B	LVTTL0D	General purpose I/O 27
Miscellaneous	GPIO_28	N4	B	LVTTL0D	General purpose I/O 28
Miscellaneous	GPIO_29	N5	B	LVTTL0D	General purpose I/O 29
Miscellaneous	GPIO_30	N6	B	LVTTL0D	General purpose I/O 30
Miscellaneous	GPIO_31	N7	B	LVTTL0D	General purpose I/O 31
Miscellaneous	GPIO_32/I2C_SDA	N8	B	LVTTL0D	General purpose I/O 32 (also I2C data)
Miscellaneous	GPIO_33/I2C_SCL	N9	B	LVTTL0D	General purpose I/O 33 (also I2C clock)
Miscellaneous	GPIO_34	N10	B	LVTTL0D	General purpose I/O 34
Miscellaneous	GPIO_35	N11	B	LVTTL0D	General purpose I/O 35
Miscellaneous	GPIO_36	P5	B	LVTTL0D	General purpose I/O 36
Miscellaneous	GPIO_37	P6	B	LVTTL0D	General purpose I/O 37
Miscellaneous	GPIO_38	P7	B	LVTTL0D	General purpose I/O 38
Miscellaneous	GPIO_39	P8	B	LVTTL0D	General purpose I/O 39
Miscellaneous	MODE0	B10	I	LVTTL	Mode select input bit 0. Internally pulled low.
Miscellaneous	MODE1	B11	I	LVTTL	Mode select input bit 1. Internally pulled low.
Miscellaneous	MODE2	R6	I	LVTTL	Mode select input bit 2. Internally pulled low. Do not connect.
Miscellaneous	MODE3	R10	I	LVTTL	Mode select input bit 3. Internally pulled low. Do not connect.
Miscellaneous	PADDR2	T8	I	LVTTL	Port address bit 2. Internally pulled low.
Miscellaneous	PADDR3	R8	I	LVTTL	Port address bit 3. Internally pulled low.
Miscellaneous	PADDR4	T6	I	LVTTL	Port address bit 4. Internally pulled low.
Miscellaneous	RCOMP	R12		Analog	Resistor comparator, complement

Miscellaneous	RCOMPP	T12		Analog	Resistor comparator, true
Miscellaneous	RESETN	A9	I	LVTTTL	Reset. Low= Reset. Internally pulled high.
Miscellaneous	TDION	C4		Analog	Temperature diode, complement.
Miscellaneous	TDIOP	C5		Analog	Temperature diode, true.
Power and Ground	GND	A1	P	GND	Ground
Power and Ground	GND	A2	P	GND	Ground
Power and Ground	GND	A3	P	GND	Ground
Power and Ground	GND	A14	P	GND	Ground
Power and Ground	GND	A15	P	GND	Ground
Power and Ground	GND	A16	P	GND	Ground
Power and Ground	GND	B3	P	GND	Ground
Power and Ground	GND	B14	P	GND	Ground
Power and Ground	GND	C1	P	GND	Ground
Power and Ground	GND	C2	P	GND	Ground
Power and Ground	GND	C3	P	GND	Ground
Power and Ground	GND	C13	P	GND	Ground
Power and Ground	GND	C14	P	GND	Ground
Power and Ground	GND	C15	P	GND	Ground
Power and Ground	GND	C16	P	GND	Ground
Power and Ground	GND	D3	P	GND	Ground
Power and Ground	GND	D14	P	GND	Ground
Power and Ground	GND	E1	P	GND	Ground
Power and Ground	GND	E2	P	GND	Ground
Power and Ground	GND	E3	P	GND	Ground
Power and Ground	GND	E14	P	GND	Ground
Power and Ground	GND	E15	P	GND	Ground
Power and Ground	GND	E16	P	GND	Ground
Power and Ground	GND	F3	P	GND	Ground
Power and Ground	GND	F5	P	GND	Ground
Power and Ground	GND	F6	P	GND	Ground
Power and Ground	GND	F9	P	GND	Ground
Power and Ground	GND	F12	P	GND	Ground
Power and Ground	GND	F13	P	GND	Ground
Power and Ground	GND	F14	P	GND	Ground
Power and Ground	GND	G1	P	GND	Ground
Power and Ground	GND	G2	P	GND	Ground
Power and Ground	GND	G3	P	GND	Ground
Power and Ground	GND	G6	P	GND	Ground
Power and Ground	GND	G9	P	GND	Ground
Power and Ground	GND	G12	P	GND	Ground
Power and Ground	GND	G14	P	GND	Ground
Power and Ground	GND	G15	P	GND	Ground

Power and Ground	GND	G16	P	GND	Ground
Power and Ground	GND	H3	P	GND	Ground
Power and Ground	GND	H6	P	GND	Ground
Power and Ground	GND	H9	P	GND	Ground
Power and Ground	GND	H12	P	GND	Ground
Power and Ground	GND	H14	P	GND	Ground
Power and Ground	GND	J1	P	GND	Ground
Power and Ground	GND	J2	P	GND	Ground
Power and Ground	GND	J3	P	GND	Ground
Power and Ground	GND	J6	P	GND	Ground
Power and Ground	GND	J9	P	GND	Ground
Power and Ground	GND	J12	P	GND	Ground
Power and Ground	GND	J13	P	GND	Ground
Power and Ground	GND	J14	P	GND	Ground
Power and Ground	GND	J15	P	GND	Ground
Power and Ground	GND	J16	P	GND	Ground
Power and Ground	GND	K3	P	GND	Ground
Power and Ground	GND	K6	P	GND	Ground
Power and Ground	GND	K9	P	GND	Ground
Power and Ground	GND	K12	P	GND	Ground
Power and Ground	GND	K14	P	GND	Ground
Power and Ground	GND	L1	P	GND	Ground
Power and Ground	GND	L2	P	GND	Ground
Power and Ground	GND	L3	P	GND	Ground
Power and Ground	GND	L6	P	GND	Ground
Power and Ground	GND	L9	P	GND	Ground
Power and Ground	GND	L12	P	GND	Ground
Power and Ground	GND	L14	P	GND	Ground
Power and Ground	GND	L15	P	GND	Ground
Power and Ground	GND	L16	P	GND	Ground
Power and Ground	GND	M3	P	GND	Ground
Power and Ground	GND	M13	P	GND	Ground
Power and Ground	GND	M14	P	GND	Ground
Power and Ground	GND	N1	P	GND	Ground
Power and Ground	GND	N2	P	GND	Ground
Power and Ground	GND	N3	P	GND	Ground
Power and Ground	GND	N14	P	GND	Ground
Power and Ground	GND	N15	P	GND	Ground
Power and Ground	GND	N16	P	GND	Ground
Power and Ground	GND	P3	P	GND	Ground
Power and Ground	GND	P14	P	GND	Ground
Power and Ground	GND	R1	P	GND	Ground
Power and Ground	GND	R2	P	GND	Ground
Power and Ground	GND	R3	P	GND	Ground

Power and Ground	GND	R4	P	GND	Ground
Power and Ground	GND	R13	P	GND	Ground
Power and Ground	GND	R14	P	GND	Ground
Power and Ground	GND	R15	P	GND	Ground
Power and Ground	GND	R16	P	GND	Ground
Power and Ground	GND	T1	P	GND	Ground
Power and Ground	GND	T4	P	GND	Ground
Power and Ground	GND	T13	P	GND	Ground
Power and Ground	GND	T16	P	GND	Ground
Power and Ground	VDDAH	F4	P	Supply	1.0 V power supply for host side analog
Power and Ground	VDDAH	G5	P	Supply	1.0 V power supply for host side analog
Power and Ground	VDDAH	H5	P	Supply	1.0 V power supply for host side analog
Power and Ground	VDDAH	J5	P	Supply	1.0 V power supply for host side analog
Power and Ground	VDDAH	K5	P	Supply	1.0 V power supply for host side analog
Power and Ground	VDDAH	L4	P	Supply	1.0 V power supply for host side analog
Power and Ground	VDDAL	F11	P	Supply	1.0 V power supply for line side analog
Power and Ground	VDDAL	G10	P	Supply	1.0 V power supply for line side analog
Power and Ground	VDDAL	H10	P	Supply	1.0 V power supply for line side analog
Power and Ground	VDDAL	J10	P	Supply	1.0 V power supply for line side analog
Power and Ground	VDDAL	K10	P	Supply	1.0 V power supply for line side analog
Power and Ground	VDDAL	L11	P	Supply	1.0 V power supply for line side analog
Power and Ground	VDDHSH	G4	P	Supply	1.2 V power supply for host side IOs
Power and Ground	VDDHSH	H4	P	Supply	1.2 V power supply for host side IOs
Power and Ground	VDDHSH	J4	P	Supply	1.2 V power supply for host side IOs
Power and Ground	VDDHSH	K4	P	Supply	1.2 V power supply for host side IOs
Power and Ground	VDDHSL	G11	P	Supply	1.2 V power supply for line side IOs
Power and Ground	VDDHSL	H11	P	Supply	1.2 V power supply for line side IOs
Power and Ground	VDDHSL	J11	P	Supply	1.2 V power supply for line side IOs

Power and Ground	VDDHSL	K11	P	Supply	1.2 V power supply for line side IOs
Power and Ground	VDDL	F8	P	Supply	1.0 V power supply for chip core
Power and Ground	VDDL	F10	P	Supply	1.0 V power supply for chip core
Power and Ground	VDDL	L8	P	Supply	1.0 V power supply for chip core
Power and Ground	VDDL	L10	P	Supply	1.0 V power supply for chip core
Power and Ground	VDDLRL	G7	P	Supply	1.0 V power supply for chip core
Power and Ground	VDDLRL	G8	P	Supply	1.0 V power supply for chip core
Power and Ground	VDDLRL	H7	P	Supply	1.0 V power supply for chip core
Power and Ground	VDDLRL	H8	P	Supply	1.0 V power supply for chip core
Power and Ground	VDDLRL	J7	P	Supply	1.0 V power supply for chip core
Power and Ground	VDDLRL	J8	P	Supply	1.0 V power supply for chip core
Power and Ground	VDDLRL	K7	P	Supply	1.0 V power supply for chip core
Power and Ground	VDDLRL	K8	P	Supply	1.0 V power supply for chip core
Power and Ground	VDDMDIO	L5	P	Supply	MDIO power supply
Power and Ground	VDDTTL	F7	P	Supply	LVTTL power supply
Power and Ground	VDDTTL	L7	P	Supply	LVTTL power supply
Receive and Transmit Path	RXIN0N	B16	I	CML	Line receive channel 0 input data, complement
Receive and Transmit Path	RXIN0P	B15	I	CML	Line receive channel 0 input data, true
Receive and Transmit Path	RXIN1N	F16	I	CML	Line receive channel 1 input data, complement
Receive and Transmit Path	RXIN1P	F15	I	CML	Line receive channel 1 input data, true
Receive and Transmit Path	RXIN2N	K16	I	CML	Line receive channel 2 input data, complement
Receive and Transmit Path	RXIN2P	K15	I	CML	Line receive channel 2 input data, true
Receive and Transmit Path	RXIN3N	P16	I	CML	Line receive channel 3 input data, complement
Receive and Transmit Path	RXIN3P	P15	I	CML	Line receive channel 3 input data, true
Receive and Transmit Path	RXOUT0N	B1	O	CML	Host transmit channel 0 output data, complement

Receive and Transmit Path	RXOUT0P	B2	O	CML	Host transmit channel 0 output data, true
Receive and Transmit Path	RXOUT1N	F1	O	CML	Host transmit channel 1 output data, complement
Receive and Transmit Path	RXOUT1P	F2	O	CML	Host transmit channel 1 output data, true
Receive and Transmit Path	RXOUT2N	K1	O	CML	Host transmit channel 2 output data, complement
Receive and Transmit Path	RXOUT2P	K2	O	CML	Host transmit channel 2 output data, true
Receive and Transmit Path	RXOUT3N	P1	O	CML	Host transmit channel 3 output data, complement
Receive and Transmit Path	RXOUT3P	P2	O	CML	Host transmit channel 3 output data, true
Receive and Transmit Path	TXIN0N	D1	I	CML	Host receive channel 0 input data, complement
Receive and Transmit Path	TXIN0P	D2	I	CML	Host receive channel 0 input data, true
Receive and Transmit Path	TXIN1N	H1	I	CML	Host receive channel 1 input data, complement
Receive and Transmit Path	TXIN1P	H2	I	CML	Host receive channel 1 input data, true
Receive and Transmit Path	TXIN2N	M1	I	CML	Host receive channel 2 input data, complement
Receive and Transmit Path	TXIN2P	M2	I	CML	Host receive channel 2 input data, true
Receive and Transmit Path	TXIN3N	T2	I	CML	Host receive channel 3 input data, complement
Receive and Transmit Path	TXIN3P	T3	I	CML	Host receive channel 3 input data, true
Receive and Transmit Path	TXOUT0N	D16	O	CML	Line transmit channel 0 output data, complement
Receive and Transmit Path	TXOUT0P	D15	O	CML	Line transmit channel 0 output data, true
Receive and Transmit Path	TXOUT1N	H16	O	CML	Line transmit channel 1 output data, complement
Receive and Transmit Path	TXOUT1P	H15	O	CML	Line transmit channel 1 output data, true
Receive and Transmit Path	TXOUT2N	M16	O	CML	Line transmit channel 2 output data, complement
Receive and Transmit Path	TXOUT2P	M15	O	CML	Line transmit channel 2 output data, true
Receive and Transmit Path	TXOUT3N	T15	O	CML	Line transmit channel 3 output data, complement
Receive and Transmit Path	TXOUT3P	T14	O	CML	Line transmit channel 3 output data, true
Reserved/No Connect	NC	A12			No connect

Reserved/No Connect	NC	B12			No connect
Reserved/No Connect	NC	C12			No connect
Reserved/No Connect	NC	M12			No connect
Reserved/No Connect	NC	N12			No connect
Reserved/No Connect	NC	P4			No connect
Reserved/No Connect	NC	P12			No connect
Reserved/No Connect	NC	T10			No connect
SPI	MISO	B6	O	LVTTTL	SPI slave data output
SPI	MOSI	B4	I	LVTTTL	SPI slave data input. Internally pulled low.
SPI	SCK	A6	I	LVTTTL	SPI slave clock input. Internally pulled low.
SPI	SSN	A4	I	LVTTTL	SPI slave chip select input. Internally pulled high.

## 7 Package Information

---

The VSC8257-01YMR package is a lead-free (Pb-free), 256-pin, flip chip ball grid array (FCBGA) with a 17 mm × 17 mm body size, 1 mm pin pitch, and 2.7 mm maximum height.

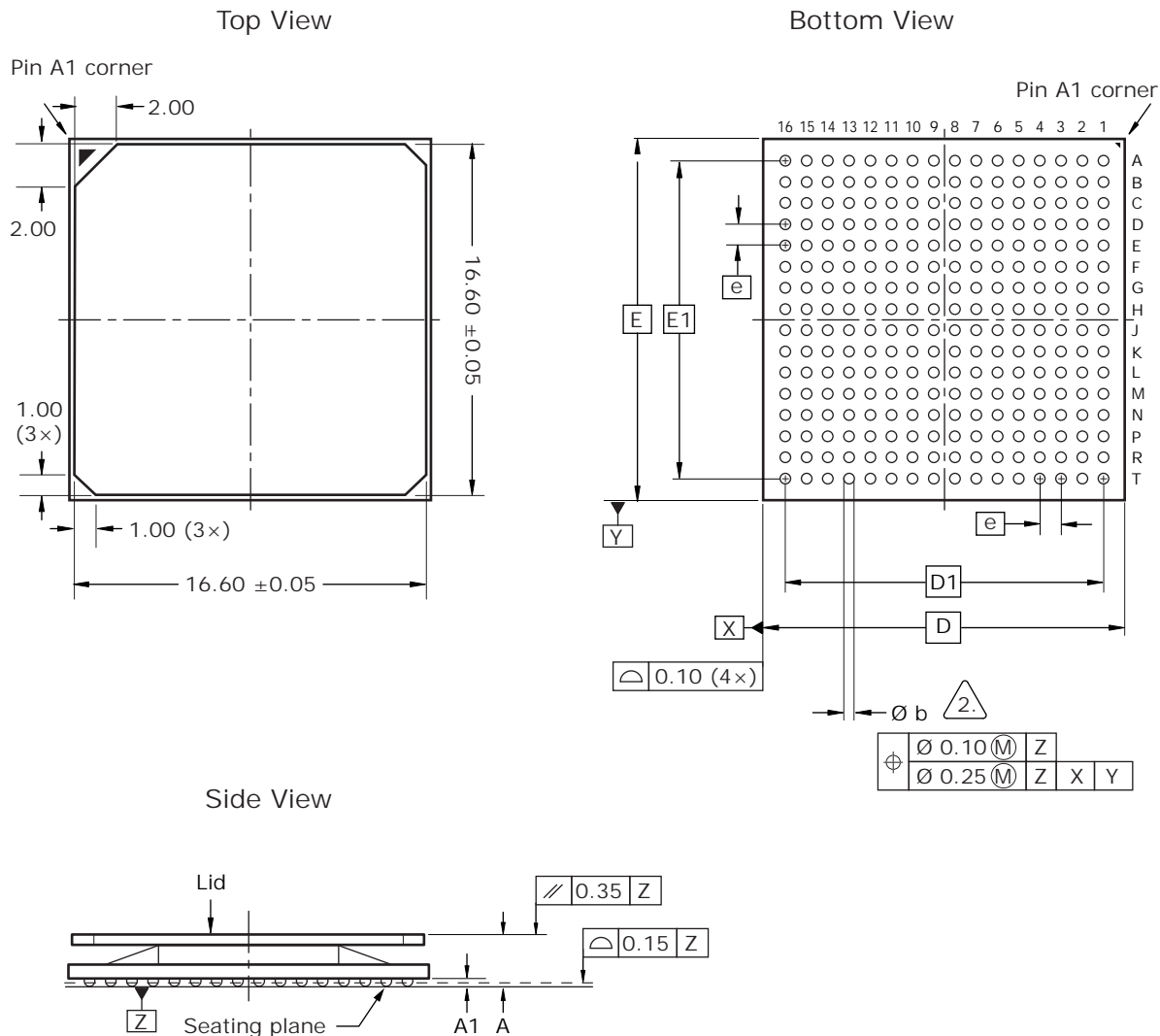
Lead-free products from Microsemi comply with the temperatures and profiles defined in the joint IPC and JEDEC standard IPC/JEDEC J-STD-020. For more information, see the IPC and JEDEC standard.

### 7.1 Package Drawing

The following illustration shows the package drawing for the VSC8257-01 device. The drawing contains the top view, bottom view, side view, detail views, dimensions, tolerances, and notes.



Figure 93 • VSC8257-01 Package



Dimensions and Tolerances

Reference	Minimum	Nominal	Maximum
A	2.20	2.45	2.70
A1	0.31		0.41
D		17.00 BSC	
E		17.00 BSC	
D1		15.00 BSC	
E1		15.00 BSC	
e		1.00 BSC	
b	0.44	0.54	0.64

Notes

1. All dimensions and tolerances are in millimeters (mm).
2. Dimension is measured at the maximum solder ball diameter, parallel to primary datum Z.
3. Radial true position is represented by typical values.

## 7.2 Thermal Specifications

Thermal specifications for this device are based on the JEDEC JESD51 family of documents. These documents are available on the JEDEC Web site at [www.jedec.org](http://www.jedec.org). The thermal specifications are modeled using a four-layer test board with two signal layers, a power plane, and a ground plane (2s2p

PCB). For more information about the thermal measurement method used for this device, see the JESD51-1 standard.

**Table 68 • Thermal Resistances**

Symbol	°C/W	Parameter
$\theta_{JCTop}$	0.7	Die junction to package case top
$\theta_{JB}$	13	Die junction to printed circuit board
$\theta_{JA}$	18	Die junction to ambient
$\theta_{JMA}$ at 1 m/s	14.5	Die junction to moving air measured at an air speed of 1 m/s
$\theta_{JMA}$ at 2 m/s	11.9	Die junction to moving air measured at an air speed of 2 m/s

To achieve results similar to the modeled thermal measurements, the guidelines for board design described in the JESD51 family of publications must be applied. For information about applications using BGA packages, see the following:

- JESD51-2A, *Integrated Circuits Thermal Test Method Environmental Conditions, Natural Convection (Still Air)*
- JESD51-6, *Integrated Circuit Thermal Test Method Environmental Conditions, Forced Convection (Moving Air)*
- JESD51-8, *Integrated Circuit Thermal Test Method Environmental Conditions, Junction-to-Board*
- JESD51-9, *Test Boards for Area Array Surface Mount Package Thermal Measurements*

## 7.3 Moisture Sensitivity

This device is rated moisture sensitivity level 4 as specified in the joint IPC and JEDEC standard IPC/JEDEC J-STD-020. For more information, see the IPC and JEDEC standard.

## 8 Design Considerations

---

This section provides information about design considerations for the VSC8257-01 device.

### 8.1 SPI bus speeds

The maximum speed enabled on the 4-pin slave SPI bus is 15.4 MHz in normal mode and 30 MHz in fast mode. The maximum speed for the 3-pin push out only SPI is 40 MHz.

### 8.2 Device clocking

Use the LREFCLK and the HREFCK inputs for the line-side and host-side PLLs, respectively. Both LREFCLK and HREFCK inputs are required at all times and must be synchronous. They can be 125 MHz or 156.25 MHz

Use the API call to set up the HREFCLK and LREFCLK pins for low swing or high swing clock inputs.

### 8.3 10GBASE-KR autonegotiation and link training

10GBASE-KR autonegotiation and link training (per IEEE 802.3, clauses 72 and 73) are only supported in 10G mode. Autonegotiation and link training is not supported in 1G backplane applications.

For compatibility reasons, the 10GBASE-KR autonegotiation and link training function must be disabled when the device is in repeater mode. While in this mode, the host-side transmitter clock is set during initialization to synchronize to the line-side receiver clock, and the line-side transmitter clock is set to synchronize to the host-side receiver clock.

Any cross-connect operation should be avoided under all circumstances during the process of KR autonegotiation and link training.

### 8.4 Low-power mode and SerDes calibration

SerDes re-initialization and re-calibration is required when the PHY comes out of the low power mode.

Use the API to enable the required low power and re-calibration functionality instead of the low power enabling bits at 1x0000.11, 2x0000.11, 3x0000.11, or 4x0000.11, which force a reset of the SerDes registers

### 8.5 Low power mode with failover switching

Do not enable the low power mode when the failover switch is enabled.

The device is not intended to support the low power mode of operation when the failover switch is enabled. When low power mode is enabled in one channel, the data flow of the other channel could be adversely affected if the failover switch is enabled.

### 8.6 Flow control with failover switching

Both Tx and Rx data paths of the channel have to be switched at the same time when flow control is enabled. The Tx data path of one channel in one direction and the Rx data path of another channel in the opposite direction cannot be mixed.

### 8.7 GPIO as TOSI

A small value pull-up is needed when a GPIO pin is used as TOSI. For more information, contact your Microsemi representative.

### 8.8 Limited 1G status reporting

In 1G mode, the 1G status signal from the 1G PCS block is driven by a sticky bit rather than a latched bit, and so is useful only for link down (and not useful for link up conditions). Also, in 1000BASE-X mode, the

link up indicator does not include AN done status. This does not apply to 1G bypass mode because the PCS block is bypassed and there is no 1G status at all.

## 8.9 1G mode operation

Designers should be aware of the following restrictions when operating the device in 1G mode.

- The 1G physical coding sublayer (PCS) implements 1000BASE-X (as specified by IEEE 802.3, clause 36) and autonegotiation (as specified by IEEE 802.3, clause 37). Clause 37 autonegotiation only applies to 1000BASE-SX and -LX optical modules.
- In non-repeater mode, CuSFP (SGMII) with a 1G rate could be supported in the data path, but all autonegotiation features must be disabled by the user. 10/100 Mbps intermediary line rates of those modules are not supported by the PHY data path.
- In repeater mode, CuSFP (SGMII) with a 10/100M data rate through oversampling in 1G mode would work through the data path. In this configuration, autonegotiation is performed between the host MAC and the SFP+ module, without the intervention of the repeater.

## 8.10 Loopbacks in 10G WAN mode

Loopbacks L1, L2, and L2C are not available in 10G WAN mode if jumbo frames are used.

## 8.11 Timestamp errors due to IEEE 1588 reference clock interruption

After 1588 clock interruption, a local time counter reload using the Unified API is required.

## 9 Ordering Information

---

The VSC8257YMR-01 package is a lead-free (Pb-free), 256-pin, flip chip ball grid array (FCBGA) with a 17 mm × 17 mm body size, 1 mm pin pitch, and 2.7 mm maximum height.

Lead-free products from Microsemi comply with the temperatures and profiles defined in the joint IPC and JEDEC standard IPC/JEDEC J-STD-020. For more information, see the IPC and JEDEC standard.

The following table lists the ordering information for the VSC8257-01 device.

**Table 69 • Ordering Information**

<b>Part Order Number</b>	<b>Description</b>
VSC8257YMR-01	Lead-free, 256-pin FCBGA with a 17 mm × 17 mm body size, 1 mm pin pitch, and 2.7 mm maximum height.

## X-ON Electronics

Largest Supplier of Electrical and Electronic Components

*Click to view similar products for [Ethernet ICs category](#):*

*Click to view products by [Microchip manufacturer](#):*

Other Similar products are found below :

[EZFM6324A S LKA5](#) [EZFM6364A S LKA7](#) [12200BS23MM](#) [EZFM5224A S LKA3](#) [VSC8522XJQ-02](#) [WGI219LM SLKJ3](#) [JL82599EN S R1ZS](#) [EZFM6348A S LKA6](#) [WGI219V SLKJ5](#) [BCM84793A1KFSBG](#) [BCM56680B1KFSBLG](#) [BCM53402A0KFSBG](#) [BCM56960B1KFSBG](#) [EZX557AT2 S LKVX](#) [BCM56842A1KFTBG](#) [BCM56450B1KFSBG](#) [EZX557AT S LKW4](#) [RTL8153-VC-CG](#) [CH395L](#) [BCM56864A1IFSBG](#) [WGI219LM SLKJ2](#) [KSZ8462FHLLI](#) [KSZ8841-16MVLI](#) [KSZ9897STXC](#) [KSZ8842-16MVLI](#) [KSZ8893MQL](#) [VSC8244XHG](#) [ADIN2111BCPZ](#) [FIDO2100BGA128IR0](#) [FIDO5210BBCZ](#) [FIDO5200CBCZ](#) [ADIN1110BCPZ](#) [ADIN1110CCPZ](#) [ADIN1100BCPZ](#) [ADIN1110CCPZ-R7](#) [ADIN1100CCPZ-R7](#) [DM9000EP](#) [DM9161AEP](#) [HG82567LM S LAVY](#) [LAN9210-ABZJ](#) [LAN9221-ABZJ](#) [LAN9221I-ABZJ](#) [LAN9211-ABZJ](#) [EZFM4105F897C S LKAM](#) [EZFM4224F1433E S LKAD](#) [EZFM4224F1433I S LKAE](#) [FBFM2112F897C S LJLS](#) [JL82576GB S LJBM](#) [JL82576NS S LJBP](#) [RC82545GM 855561](#)