

# VSC8531

## Single Port Gigabit Ethernet Copper PHY with RGMII/RMII Interfaces

Low-power, small form-factor Cu PHY with IEEE 802.3az Energy Efficient Ethernet (EEE) and Wake-on-LAN (WoL), with widest I/O LVCMOS support.

The VSC8531 device, offered in a tiny 6 mm x 6 mm single-row QFN package, is designed for space-constrained 10/100/1000BASE-T applications. It features integrated line-side termination to conserve board space, lower EMI, and improve system performance. Additionally, integrated RGMII version 2.0 standard timing compliant compensation eliminates the need for on-board delay lines.

The device supports the industry's widest range of LVCMOS levels for a parallel MAC interface including 1.5 V, 1.8 V, 2.5 V, and 3.3 V, as well as 1.2 V, 1.5 V, 1.8 V, 2.5 V, and 3.3 V support on the MDIO/MDC interface.

VSC8531 includes Microsemi's EcoEthernet™ 2.0 technology with Energy Efficient Ethernet and power saving features to reduce power based on link state and cable reach. It optimizes power consumption at all link operating speeds, and features Wake-on-LAN power management using magic packets.

### Highlights

- EcoEthernet™ 2.0, with Energy Efficient Ethernet
- Widest voltage range, fully-compliant parallel MAC interface device
- Tiny 6 mm x 6 mm QFN package
- Configurable drive strength on MAC interface enables better control of system-level EMI/EMC

### Applications

- 3D printers, 2D printers
- IoT applications, such as digital signage and eHealth
- Consumer electronics, such as CPE, UHD TV, media servers, and NAS

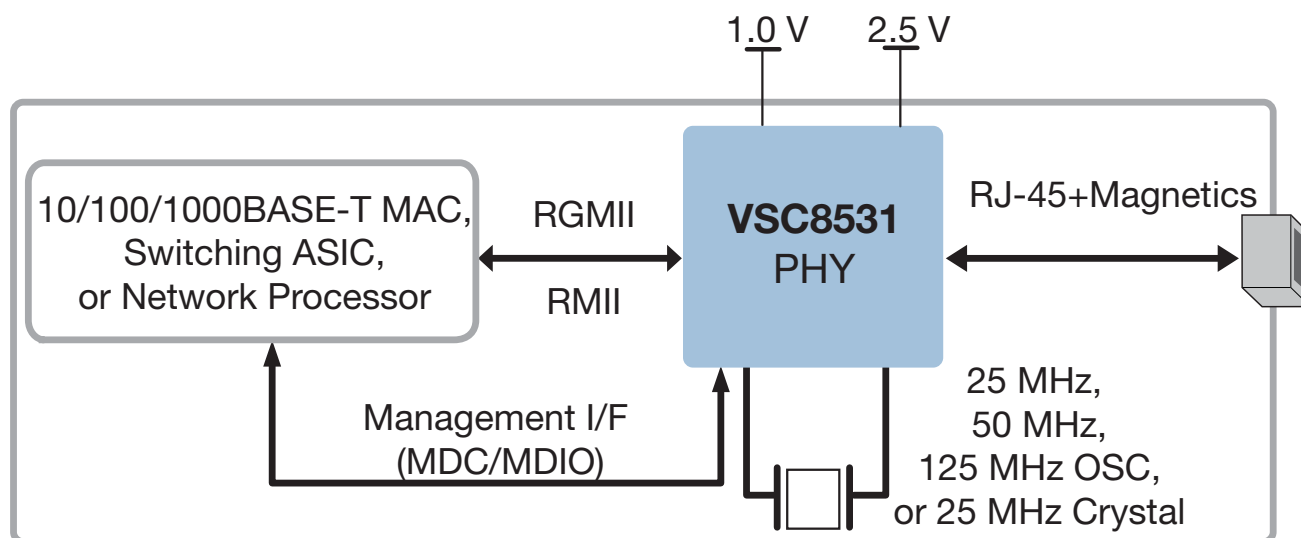

# VSC8531

## Single Port Gigabit Ethernet Copper PHY with RGMII/RMII Interfaces

### Superior PHY and Interface Technology

- 10/100/1000BASE-T Ethernet copper transceiver (IEEE 802.3ab compliant) with Microsemi exclusive non-TDR based VeriPHY™ cable diagnostics software enables testing without taking down link or impacting data bandwidth while in 1000BASE-T mode
- Patented line driver with low-EMI voltage mode and integrated line-side termination resistors
- WOL support using magic packets
- HP Auto-MDIX and manual MDI/MDIX support
- RGMII/RMII MAC interface with widest voltage range support in the industry: 1.5 V, 1.8 V, 2.5 V, and 3.3 V (LVCMOS)
- Jumbo frame support up to 16 kilobytes with programmable synchronization FIFOs
- Additional internal FIFO located on ingress side enables support for EtherCAT® applications

### Best-in-Class Power Consumption

- EcoEthernet™ 2.0 green energy efficiency with ActiPHY™, PerfectReach™, and IEEE 802.3az EEE
- Clause 45 registers to support IEEE 802.3az EEE and IEEE 802.3bf
- Fully optimized power consumption for all link speeds
- 10BASE-Te mode support enables even lower power consumption than 10BASE-T

### Key Specifications

- Compliant with IEEE 802.3 (10BASE-T, 10BASE-Te, 100BASE-TX, and 1000BASE-T)

- Supports RGMII (version 1.3) and RMII (version 1.2) at 1.5 V, 1.8 V, 2.5 V, and 3.3 V LVCMOS
- RGMII version 2.0 timing compliant
- Supports clocking from 25 MHz crystal or 25/50/125 MHz oscillator
- Microcontroller-free configurability through hardware strapping
- Optionally reports if a link partner is requesting inline Power over Ethernet (PoE and PoE+)
- Optional stand-alone capability supports even the most cost-sensitive Ethernet enabled designs
- Devices support operating temperatures of -40 °C ambient to 125 °C junction or 0 °C ambient to 125 °C junction
- Available in 6 mm x 6 mm, 48-pin single-row QFN package

### Related Products

Visit [www.microsemi.com](http://www.microsemi.com) for information about these related products:

- VSC8541/VSC8541-03: Single Port Gigabit Ethernet Copper PHY with GMII/RGMII/RMII/MII Interface
- VSC8540-03: Single Port Fast Ethernet Copper PHY with Synchronous Ethernet, RGMII/MII/RMII Interface
- VSC8530-03: Single Port Industrial Grade Fast Ethernet Copper PHY with RGMII/RMII Interface

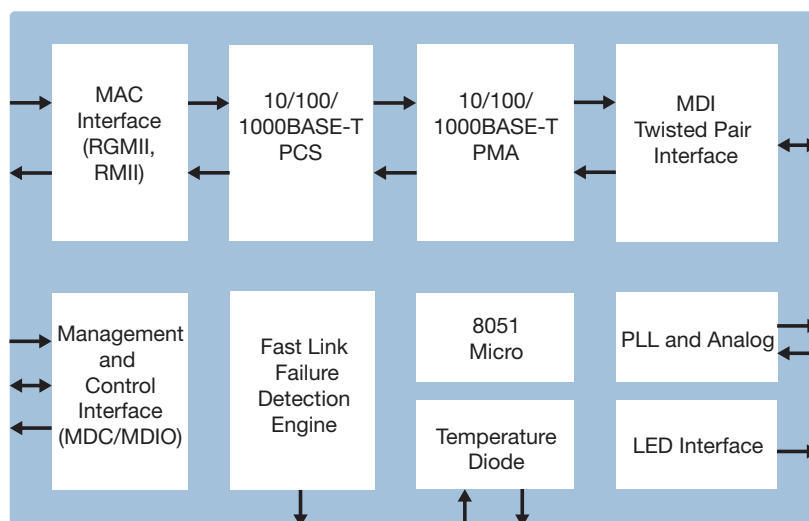

**Microsemi Corporate Headquarters**  
 One Enterprise, Aliso Viejo, CA 92656 USA  
 Within the USA: +1 (800) 713-4113  
 Outside the USA: +1 (949) 380-6100  
 Sales: +1 (949) 380-6136  
 Fax: +1 (949) 215-4996  
 email: [sales.support@microsemi.com](mailto:sales.support@microsemi.com)  
[www.microsemi.com](http://www.microsemi.com)

Microsemi Corporation (Nasdaq: MSCC) offers a comprehensive portfolio of semiconductor and system solutions for communications, defense & security, aerospace and industrial markets. Products include high-performance and radiation-hardened analog mixed-signal integrated circuits, FPGAs, SoCs and ASICs; power management products; timing and synchronization devices and precise time solutions, setting the world's standard for time; voice processing devices; RF solutions; discrete components; enterprise storage and communication solutions, security technologies and scalable anti-tamper products; Ethernet solutions; Power-over-Ethernet ICs and midspans; as well as custom design capabilities and services. Microsemi is headquartered in Aliso Viejo, Calif., and has approximately 4,800 employees globally. Learn more at [www.microsemi.com](http://www.microsemi.com).

## X-ON Electronics

Largest Supplier of Electrical and Electronic Components

*Click to view similar products for [Microchip manufacturer](#):*

Other Similar products are found below :

[ATSTK600-RC46](#) [ATF750C-10GM/883](#) [AT28C010-20FM/883](#) [MCP87022T-U/MF](#) [PIC24FJ128GB202-I/SS](#) [PIC32MZ2048ECG124-I/TL](#)  
[PIC32MZ1024ECH124-I/TL](#) [MX573NBA622M080](#) [BM71BLES1FC2-0002AA](#) [MCP73834-CNI/MF](#) [DSPIC33EP128GS702-E/SO](#)  
[PIC16C73B-20/SS](#) [DSC1001CL5-114.0000](#) [PIC18LF45K42-E/P](#) [ATXMEGA64A1U-C7U](#) [AT97SC3205T-H3M4C10B](#) [RN4871-V/RM118](#)  
[DSC1001BI5-020.0000](#) [DSC1001AE1-006.1440](#) [AT28C010E-15TU-T](#) [MIC2585-1JYTS](#) [PCM16XB1](#) [MA180024](#) [MCP121T-270E/TT](#)  
[MCP1630RD-DDBK3](#) [MCP2030DM-TPR](#) [MCP23S17T-E/SO](#) [MCP2562-HMF](#) [MCP3551DM-PCTL](#) [MCP4642T-503E/MF](#) [MCP607-I/SN](#)  
[MCP621-E/SN](#) [MIC1344YFT-EV](#) [MIC5356-JGYMME](#) [PIC10F206-E/P](#) [PIC16C73B-20/SO](#) [PIC16F1773-I/SS](#) [PIC16F677-I/P](#) [PIC16F690-](#)  
[I/SS](#) [PIC16F914-I/P](#) [PIC16LC621A-04I/SO](#) [PIC16LF1789-IMV](#) [PIC18F448-I/P](#) [PIC18F4680-E/ML](#) [PIC18F8723-I/PT](#) [PIC18LF2523-ISO](#)  
[PIC32MX230F064B-VSP](#) [PIC32MZ1024EFF144-I/PL](#) [AC164142](#) [AC164326](#)