

## Features

- Output Current in Excess of 0.5 Ampere
- Internal Thermal Overload Protection
- Internal Short-circuit Current Limiting
- High Power Dissipation Capability
- Moisture Sensitivity Level 1
- Epoxy Meets UL 94 V-0 Flammability Rating
- Halogen Free Available Upon Request By Adding Suffix "-HF"
- Lead Free Finish/RoHS Compliant ("P" Suffix designates RoHS Compliant. See ordering information)

## Maximum Ratings

Parameter	Symbol	Value	Unit
Input Voltage	$V_I$	35	V
Power Dissipation	$P_D$	1.25	W
Operating Junction Temperature $T_{OJ}^*$	$T_{OPR}$	0~125	°C
Storage Temperature Range	$T_{STG}$	-65~125	°C
Thermal Resistance junction to Ambient	$R_{\theta JA}$	100	°C/W

# Three-Terminal Positive Voltage Regulators

## DPAK(TO-252)

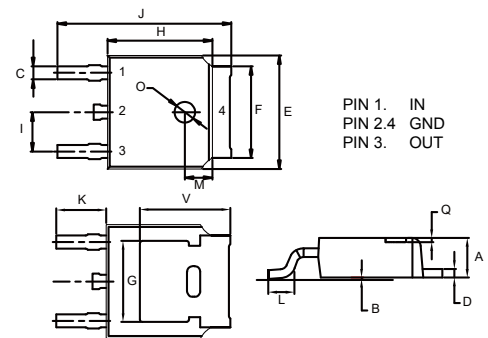

### DIMENSIONS

DIM	INCHES		MM		NOTE
	MIN	MAX	MIN	MAX	
A	0.087	0.094	2.20	2.40	
B	0.000	0.005	0.00	0.13	
C	0.026	0.034	0.66	0.86	
D	0.018	0.023	0.46	0.58	
E	0.256	0.264	6.50	6.70	
F	0.201	0.215	5.10	5.46	
G	0.190		4.83		TYP.
H	0.236	0.244	6.00	6.20	
I	0.086	0.094	2.18	2.39	
J	0.386	0.409	9.80	10.40	
K	0.114		2.90		TYP.
L	0.055	0.067	1.40	1.70	
M	0.063		1.60		TYP.
O	0.043	0.051	1.10	1.30	
Q	0.000	0.012	0.00	0.30	
V	0.211		5.35		TYP.

**Electrical Characteristics**

( $V_i=10V$ ,  $I_o=350mA$ ,  $0^\circ C < T_j < 125^\circ C$ ,  $C_i=0.33\mu F$ ,  $C_o=0.1\mu F$ , Unless Otherwise Specified)

Parameter	Symbol	Test Conditions	Min	Typ	Max	Unit
Output Voltage	$V_o$	$T_j=25^\circ C$	4.8	5.0	5.2	V
		$7V \leq V_i \leq 20V$ , $5mA \leq I_o \leq 350mA$ , $P_D=15W$	4.75	5.0	5.25	V
Load Regulation	$\Delta V_o$	$5mA \leq I_o \leq 500mA$ , $T_j=25^\circ C$	-	15	100	mV
		$5mA \leq I_o \leq 200mA$ , $T_j=25^\circ C$	-	5.0	50	mV
Line Regulation	$\Delta V_o$	$7.0V \leq V_i \leq 25V$ , $I_o=0.5A$	-	3.0	100	mV
		$8.0V \leq V_i \leq 25V$ , $I_o=0.5A$	-	1.0	50	mV
Quiescent Current	$I_q$	$T_j=25^\circ C$	-	4.2	6.0	mA
Quiescent Current Change	$\Delta I_q$	$8V \leq V_i \leq 25V$ , $I_o=200mA$ , $5mA \leq I_o \leq 350mA$	-	-	0.8	mA
			-	-	0.5	mA
Output Noise Voltage	$V_N$	$10Hz \leq f \leq 120Hz$	-	40	200	$\mu V$
Ripple Rejection	RR	$8V \leq V_i \leq 18V$ , $f=120Hz$ , $I_o=0.3A$ , $T_j=25^\circ C$	62	80	-	dB
Dropout Voltage	$V_d$	$I_o=0.35A$ , $T_j=25^\circ C$	-	2.0	2.5	V
Output Short Circuit Current	$I_{sc}$	$V_i=10V$ , $T_j=25^\circ C$	-	300	-	mA
Peak Output Current	$I_{PK}$	$T_j=25^\circ C$	-	0.7	-	A

**Typical Application**

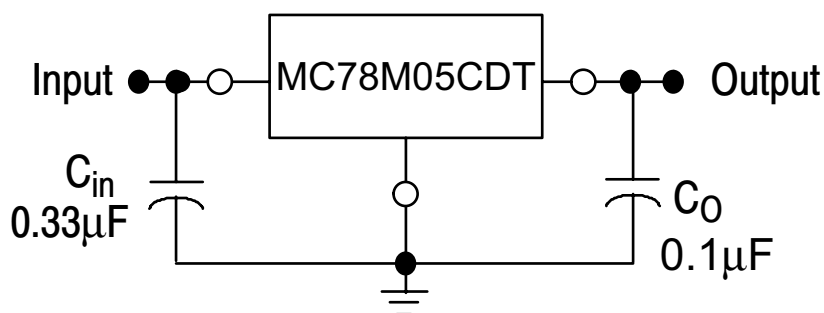

Curve Characteristics

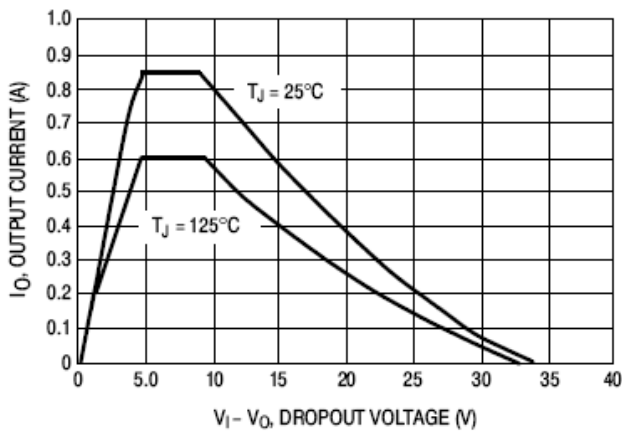

Figure 1. Peak Output Current versus Dropout Voltage

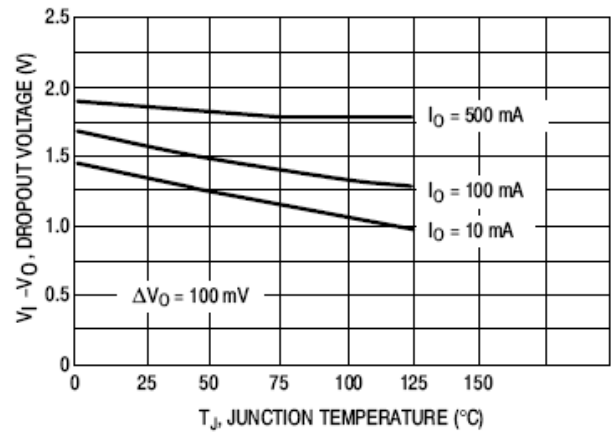

Figure 2. Dropout Voltage versus Junction Temperature

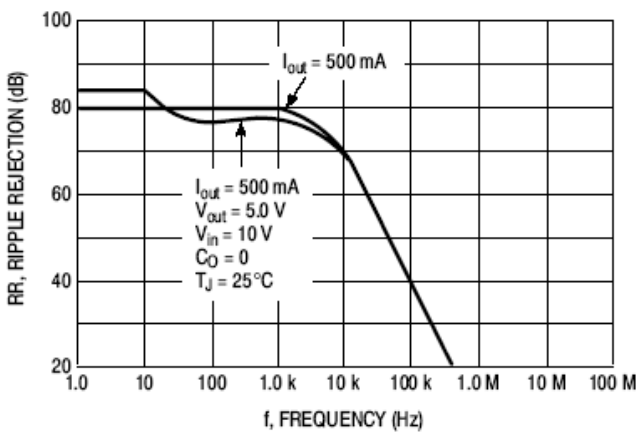

Figure 3. Ripple Rejection versus Frequency

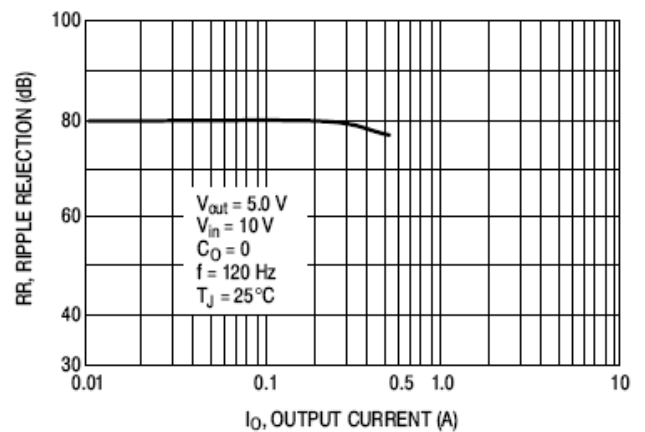

Figure 4. Ripple Rejection versus Output Current

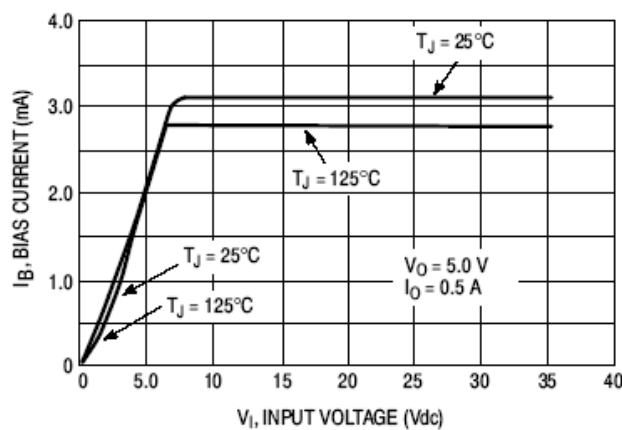

Figure 5. Bias Current versus Input Voltage

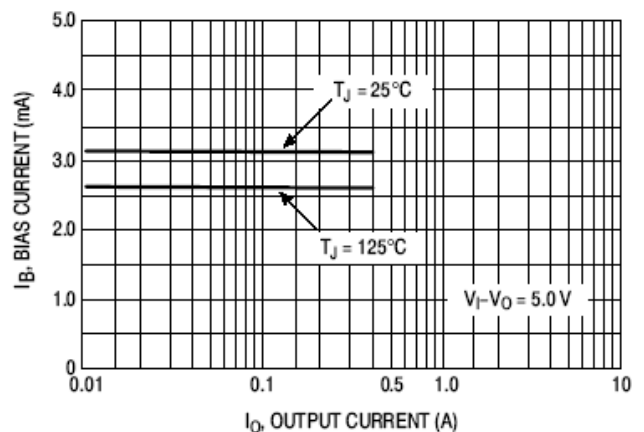

Figure 6. Bias Current versus Output Current

## Ordering Information

Device	Packing
Part Number-TP	Tape&Reel:2.5Kpcs/Reel

Note : Adding "-HF" Suffix For Halogen Free, eg. Part Number-TP-HF

### \*\*\*IMPORTANT NOTICE\*\*\*

**Micro Commercial Components Corp.** reserves the right to make changes without further notice to any product herein to make corrections, modifications , enhancements , improvements , or other changes . **Micro Commercial Components Corp.** does not assume any liability arising out of the application or use of any product described herein; neither does it convey any license under its patent rights ,nor the rights of others . The user of products in such applications shall assume all risks of such use and will agree to hold **Micro Commercial Components Corp.** and all the companies whose products are represented on our website, harmless against all damages. **Micro Commercial Components Corp.** products are sold subject to the general terms and conditions of commercial sale, as published at <https://www.mccsemi.com/Home/TermsAndConditions>.

### \*\*\*LIFE SUPPORT\*\*\*

MCC's products are not authorized for use as critical components in life support devices or systems without the express written approval of Micro Commercial Components Corporation.

### \*\*\*CUSTOMER AWARENESS\*\*\*

Counterfeiting of semiconductor parts is a growing problem in the industry. Micro Commercial Components (MCC) is taking strong measures to protect ourselves and our customers from the proliferation of counterfeit parts. MCC strongly encourages customers to purchase MCC parts either directly from MCC or from Authorized MCC Distributors who are listed by country on our web page cited below. Products customers buy either from MCC directly or from Authorized MCC Distributors are genuine parts, have full traceability, meet MCC's quality standards for handling and storage. **MCC will not provide any warranty coverage or other assistance for parts bought from Unauthorized Sources.** MCC is committed to combat this global problem and encourage our customers to do their part in stopping this practice by buying direct or from authorized distributors.

## X-ON Electronics

Largest Supplier of Electrical and Electronic Components

*Click to view similar products for [Linear Voltage Regulators](#) category:*

*Click to view products by [Micro Commercial Components \(MCC\)](#) manufacturer:*

Other Similar products are found below :

[LV56831P-E](#) [LV5684PVD-XH](#) [MCDTSA6-2R](#) [L7815ACV-DG](#) [PQ3DZ53U](#) [LV56801P-E](#) [TLE42794G](#) [L78L05CZ/1SX](#) [L78LR05DL-MA-E](#) [636416C](#) [714954EB](#) [BA033LBSG2-TR](#) [LV5680P-E](#) [L78M15CV-DG](#) [TLS202B1MBV33HTSA1](#) [L79M05T-E](#) [TLS202A1MBVHTSA1](#) [L78LR05D-MA-E](#) [NCV317MBTG](#) [NTE7227](#) [LV5680NPVC-XH](#) [LT1054CN8](#) [MP2018GZD-5-Z](#) [MP2018GZD-33-Z](#) [MIC5281-3.3YMM](#) [RT9078-28GQZ](#) [MC78L06BP-AP](#) [TA48LS05F\(TE85L,F\)](#) [TA78L12F\(TE12L,F\)](#) [TC47BR5003ECT](#) [TCR2LN12,LF\(S\)](#) [TCR2LN28,LF\(S\)](#) [TCR2LN30,LF\(S\)](#) [TCR3DF295,LM\(CT\)](#) [TCR3DF40,LM\(CT\)](#) [BA178M20CP-E2](#) [L78M12ABDT](#) [LM7812SX/NOPB](#) [LR645N3-G-P003](#) [LR645N3-G-P013](#) [ZXTR2005P5-13](#) [SCD7812BTG](#) [TCR3DF335,LM\(CT\)](#) [ZXTR2012K-13](#) [TLE42994E V33](#) [ZXTR2008K-13](#) [ZXTR2005K-13](#) [LA5693D-E](#) [L88R05DL-E](#) [ADP3300ARTZ-2.7RL7](#)