

Features

- Lead Free Finish/RoHS Compliant(Note 1) ("P" Suffix Designates Compliant. See Ordering Information)
- Epoxy Meets UL 94 V-0 Flammability Rating
- Moisture Sensitivity Level 1
- Low Forward Voltage
- Halogen Free. "Green" Device (Note 2)
- High Current Capability

Maximum Ratings

- Operating Junction Temperature Range: -55°C to +125°C(SK22-L~SK24-L)
- Operating Junction Temperature Range: -55°C to +150°C(SK26-L~SK220-L)
- Storage Temperature Range: -55°C to +150°C
- Thermal Resistance: 71°C/W Junction to Ambient(Note 3)
- Thermal Resistance: 15°C/W Junction to Lead(Note 3)

MCC Part Number	Device Marking	Maximum Recurrent Peak Reverse Voltage	Maximum RMS Voltage	Maximum DC Blocking Voltage
SK22-L	SK22	20V	14V	20V
SK23-L	SK23	30V	21V	30V
SK24-L	SK24	40V	28V	40V
SK25-L	SK25	50V	35V	50V
SK26-L	SK26	60V	42V	60V
SK28-L	SK28	80V	56V	80V
SK210-L	SK210	100V	70V	100V
SK2150-L	SK2150	150V	105V	150V
SK220-L	SK220	200V	140V	200V

Electrical Characteristics @ 25°C Unless Otherwise Specified

Average Forward Current	$I_{F(AV)}$	2.0A	$T_L=105^\circ\text{C}$
Peak Forward Surge Current	I_{FSM}	50A	8.3ms, half sine
Maximum Instantaneous Forward Voltage	V_F	SK22-L~SK24-L SK25-L~SK26-L SK28-L~SK210-L SK2150-L~SK220-L	$I_{FM}=2.0A;$ $T_J=25^\circ\text{C}^*$
		0.50V	
		0.70V	
		0.85V	
	0.90V		
Maximum Reverse Current at VR	I_R	SK22-L~SK26-L SK28-L~SK210-L SK2150-L~SK220-L	$T_J=25^\circ\text{C};$
		100µA	
		50µA	
		10µA	
Typical Junction Capacitance	C_J	SK22-L~SK24-L SK25-L~SK26-L SK28-L~SK210-L SK2150-L~SK220-L	Measured at 1.0MHz $V_R=4.0V$
		130pF	
		90pF	
		70pF	
		40pF	

*Pulse test: Pulse width 300 usec, Duty cycle 2%

1. High Temperature Solder Exemptions Applied, see EU Directive Annex 7a.
2. Halogen free "Green" products are defined as those which contain <900ppm bromine, <900ppm chlorine (<1500ppm total Br + Cl) and <1000ppm antimony compounds.
3. Mounted on P.C.B. with 0.3" x 0.3" (8.0 mm x 8.0 mm) copper pad areas.

**2 Amp Schottky Rectifier
20 to 200 Volts**

**DO-214AA
(SMB) (LEAD FRAME)**

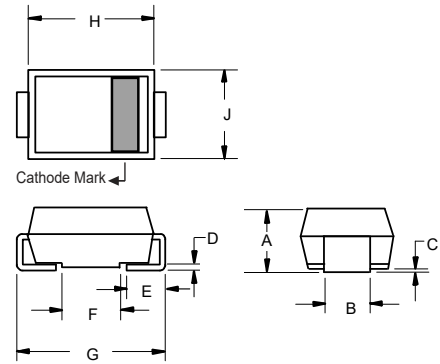

DIM	DIMENSIONS				NOTE
	INCHES		MM		
	MIN	MAX	MIN	MAX	
A	0.079	0.103	2.00	2.62	
B	0.075	0.087	1.91	2.21	
C	0.002	0.008	0.05	0.20	
D	0.006	0.012	0.15	0.31	
E	0.030	0.060	0.76	1.52	
F	0.065	0.091	1.65	2.32	
G	0.200	0.220	5.08	5.59	
H	0.160	0.191	4.06	4.85	
J	0.130	0.155	3.30	3.94	

Suggested Solder Pad Layout

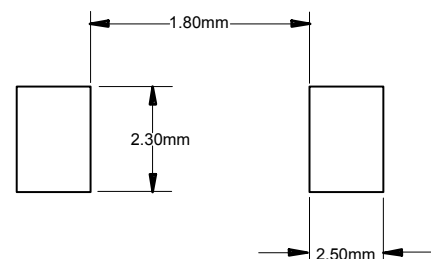

Curve Characteristics

Fig. 1 - Forward Current Derating Curve

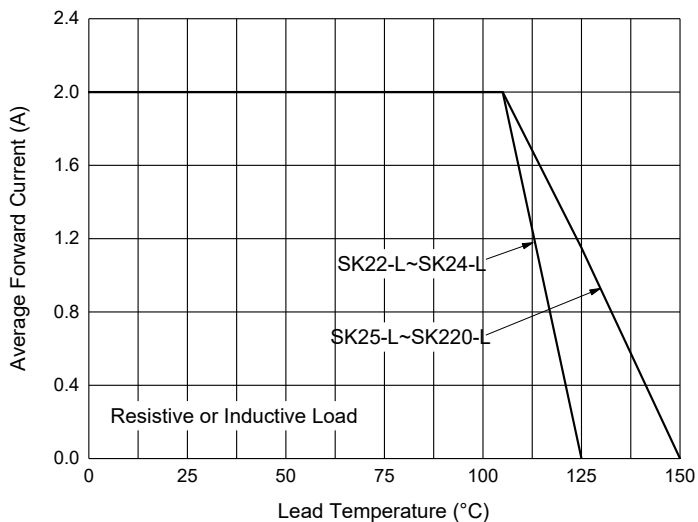

Fig. 2 - Maximum Non-Repetitive Peak Forward Surge Current

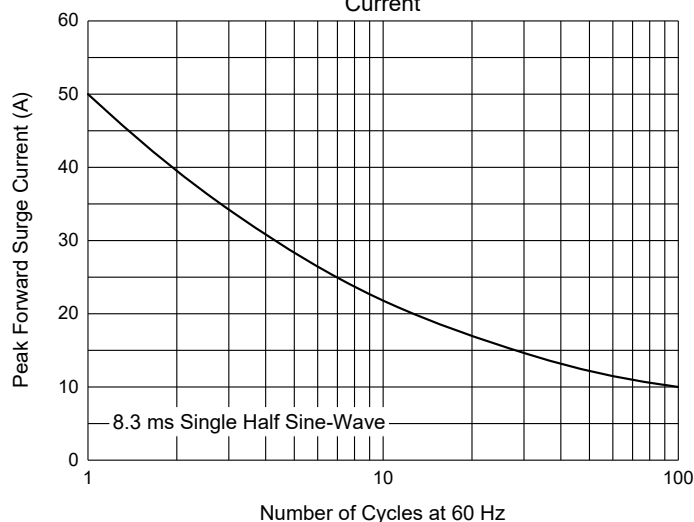

Fig. 3 - Typical Instantaneous Forward Characteristics

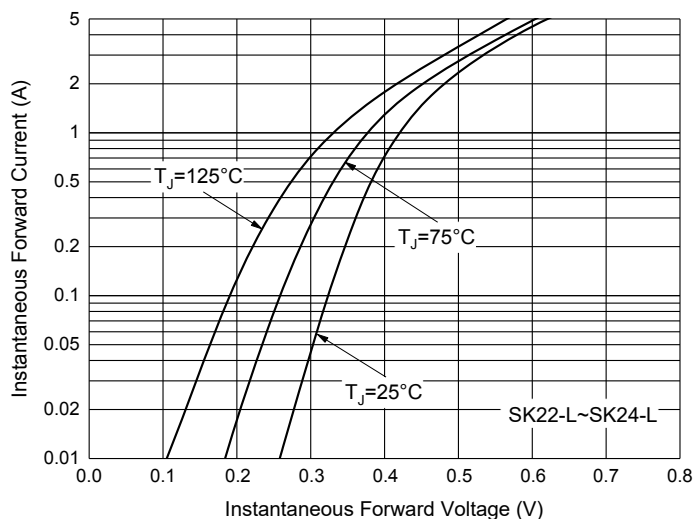

Fig. 4 - Typical Instantaneous Forward Characteristics

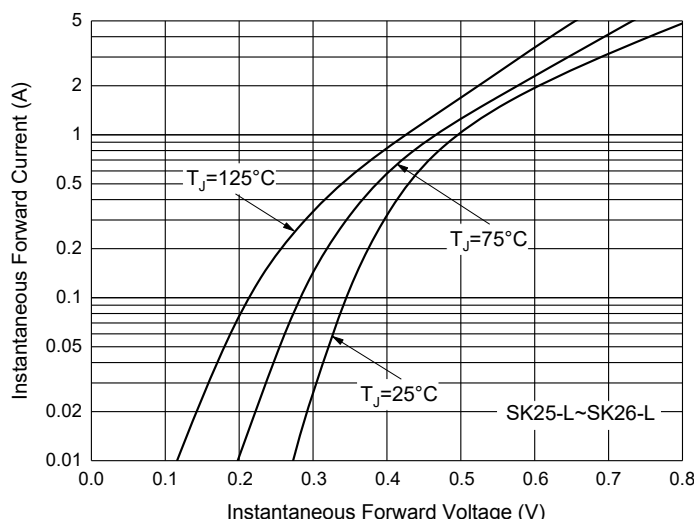

Fig. 5 - Typical Instantaneous Forward Characteristics

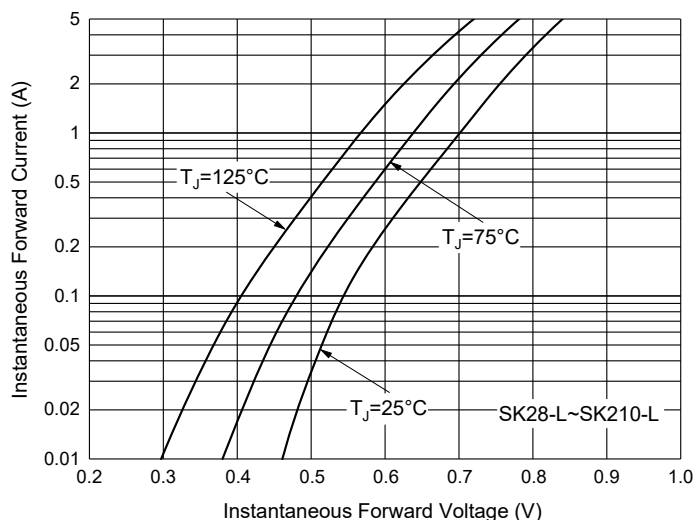
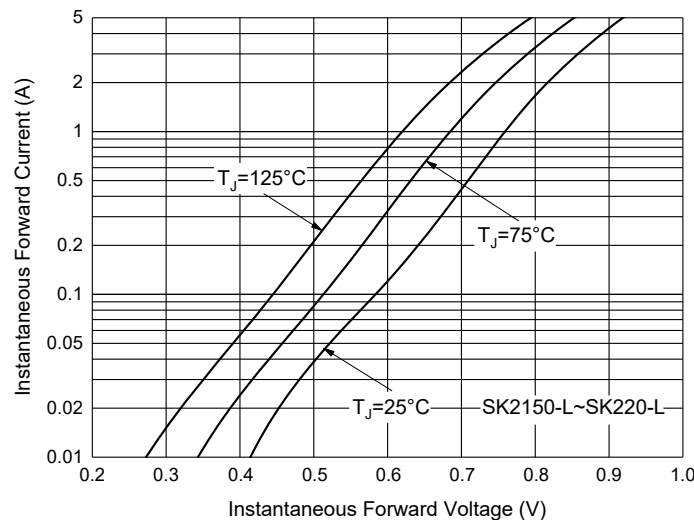

Fig. 6 - Typical Instantaneous Forward Characteristics



Curve Characteristics

Fig. 7 - Typical Reverse Leakage Characteristics

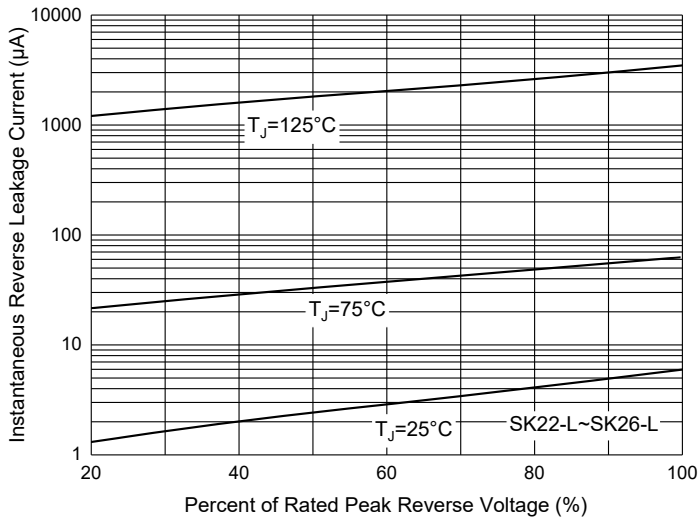

Fig. 8 - Typical Reverse Leakage Characteristics

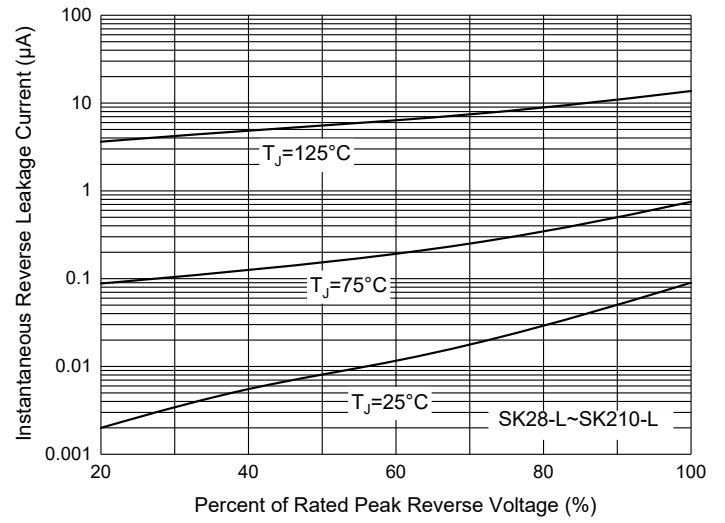
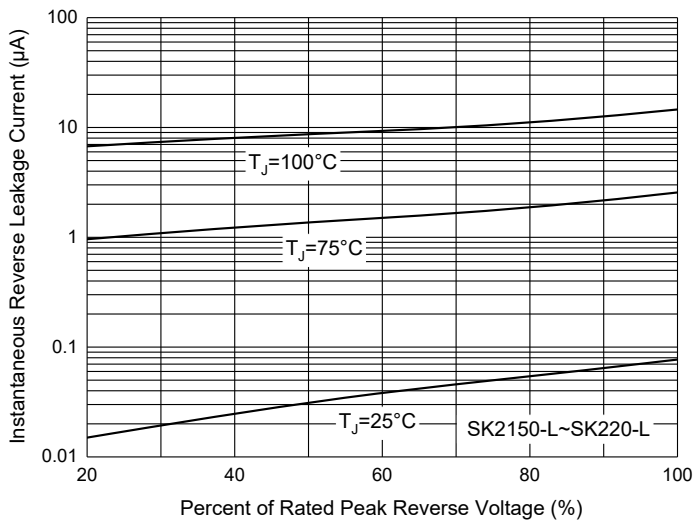

Fig. 9 - Typical Reverse Leakage Characteristics



Ordering Information

Device	Packing
SK22-LTP~SK220-LTP	Tape&Reel: 3Kpcs/Reel

IMPORTANT NOTICE

Micro Commercial Components Corp. reserves the right to make changes without further notice to any product herein to make corrections, modifications, enhancements, improvements, or other changes. **Micro Commercial Components Corp.** does not assume any liability arising out of the application or use of any product described herein; neither does it convey any license under its patent rights, nor the rights of others. The user of products in such applications shall assume all risks of such use and will agree to hold **Micro Commercial Components Corp.** and all the companies whose products are represented on our website, harmless against all damages. **Micro Commercial Components Corp.** products are sold subject to the general terms and conditions of commercial sale, as published at <https://www.mccsemi.com/Home/TermsAndConditions>.

LIFE SUPPORT

MCC's products are not authorized for use as critical components in life support devices or systems without the express written approval of Micro Commercial Components Corporation.

CUSTOMER AWARENESS

Counterfeiting of semiconductor parts is a growing problem in the industry. Micro Commercial Components (MCC) is taking strong measures to protect ourselves and our customers from the proliferation of counterfeit parts. MCC strongly encourages customers to purchase MCC parts either directly from MCC or from Authorized MCC Distributors who are listed by country on our web page cited below. Products customers buy either from MCC directly or from Authorized MCC Distributors are genuine parts, have full traceability, meet MCC's quality standards for handling and storage. **MCC will not provide any warranty coverage or other assistance for parts bought from Unauthorized Sources.** MCC is committed to combat this global problem and encourage our customers to do their part in stopping this practice by buying direct or from authorized distributors.

X-ON Electronics

Largest Supplier of Electrical and Electronic Components

Click to view similar products for [Schottky Diodes & Rectifiers](#) category:

Click to view products by [Micro Commercial Components \(MCC\)](#) manufacturer:

Other Similar products are found below :

[MA4E2039](#) [D1FH3-5063](#) [MBR0530L-TP](#) [MBR10100CT-BP](#) [MBR1545CT](#) [MMBD301M3T5G](#) [RB160M-50TR](#) [RB551V-30](#)
[BAS16E6433HTMA1](#) [BAT 54-02LRH E6327](#) [NSR05F40QNXT5G](#) [NTE555](#) [JANS1N6640](#) [SB07-03C-TB-H](#) [SB1003M3-TL-W](#) [SK310-T](#)
[SK32A-LTP](#) [SK34B-TP](#) [SS3003CH-TL-E](#) [GA01SHT18](#) [CRS10I30A\(TE85L,QM](#) [MA4E2501L-1290](#) [MBRB30H30CT-1G](#) [SB007-03C-TB-](#)
[E](#) [SK32A-TP](#) [SK33B-TP](#) [SK38B-TP](#) [NRVBM120LT1G](#) [NTE505](#) [NTSB30U100CT-1G](#) [SS15E-TP](#) [VS-6CWQ10FNHM3](#) [ACDBA1100LR-](#)
[HF](#) [ACDBA1200-HF](#) [ACDBA140-HF](#) [ACDBA2100-HF](#) [ACDBA3100-HF](#) [CDBQC0530L-HF](#) [CDBQC0240LR-HF](#) [ACDBA260LR-HF](#)
[ACDBA1100-HF](#) [SK310B-TP](#) [MA4E2502L-1246](#) [MA4E2502H-1246](#) [NRVBM120ET1G](#) [NSR01L30MXT5G](#) [NTE573](#) [NTE6081](#) [SB560](#)
[PMAD1108-LF](#)