

RV-2123-C2

Real-Time Clock Module with SPI-Bus

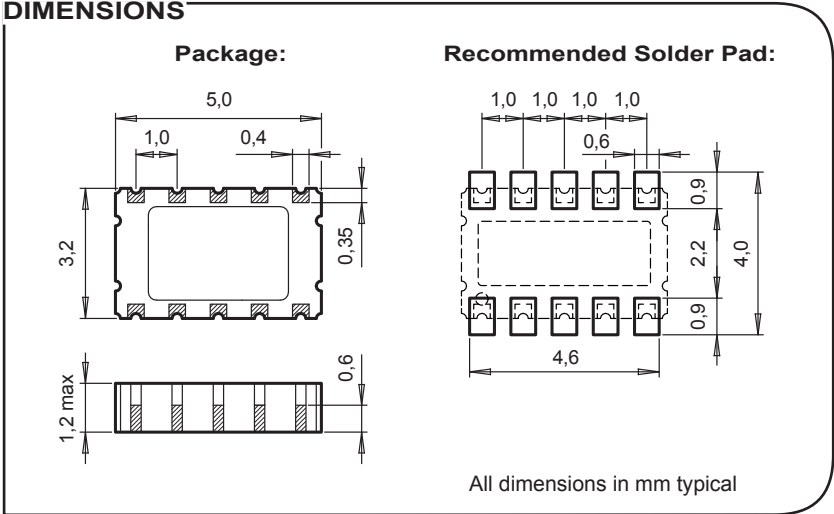

APPLICATIONS

- IoT
- Metering
- Industrial
- Portables
- Automotive
- Health Care

DESCRIPTION

The RV-2123-C2 is a SMT Real-Time Clock Module that incorporates an integrated CMOS circuit together with an XTAL. It operates under vacuum in a hermetically sealed ceramic package with glass lid.

FEATURES

- Low power consumption: 130 nA @ 3 V.
- Wide operating voltage range: 1.1 V to 5.5 V.
- Time accuracy: ± 20 ppm @ 25°C.
- Operating temperature range: -40 to +85°C.
- User programmable offset value.
- Oscillator stop detection.
- Provides year, month, weekday, date, hours, minutes and seconds.
- Automatic leap year calculation: 2000 to 2099.
- Timer and Alarm functions.
- Clock output frequencies: 32.768 kHz to 1 Hz.
- SPI-bus interface: 4-wire, 8 MHz.
- 100% Pb-free, RoHS-compliant.
- Automotive qualification according to AEC-Q200 available.

BLOCK DIAGRAM

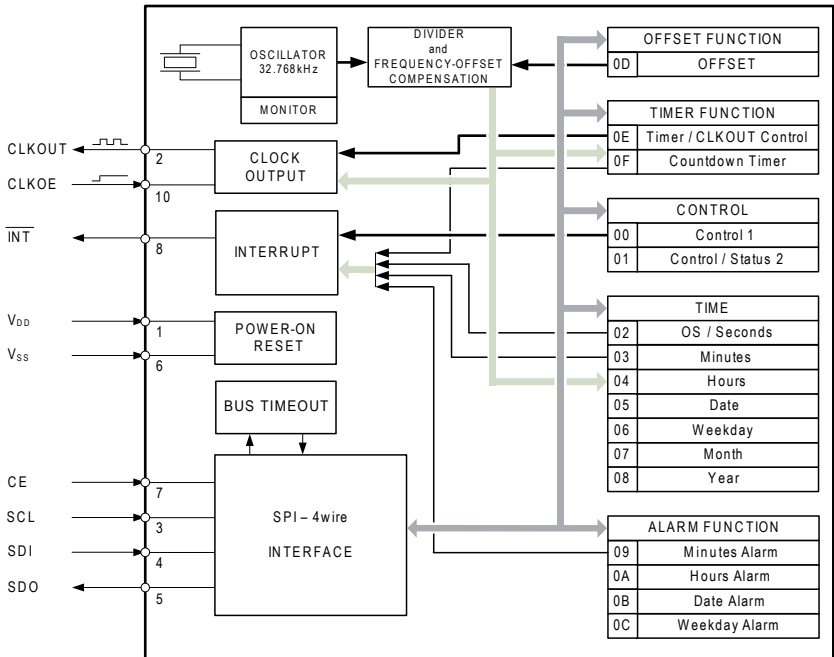

ELECTRICAL CHARACTERISTICS AT 25°C

More detailed information can be found in the Application Manual.

| | Symbol | Condition | Min. | Typ. | Max | Unit |
|--|---------------------|--|-------------------------|------|-----|------|
| Supply voltage | V _{DD} | SPI-bus active | 1.6 | | 5.5 | V |
| Supply voltage | V _{DD} | Time keeping | 1.1 | | 5.5 | V |
| Current consumption Time keeping mode | I _{DDO} | SPI-bus inactive, V _{DD} = 3 V | | 130 | 180 | nA |
| CLKOUT frequency | F _{CLKOUT} | Programmable | 32768 to 1 | | | Hz |
| Freq. tol. typ./max. | ΔF/F | @ 25°C | ±10 / ±20 ¹⁾ | | | ppm |
| Aging first year max. | ΔF/F | @ 25°C | ±3 | | | ppm |

1) Tighter frequency tolerances on request.

ENVIRONMENTAL CHARACTERISTICS

| | Conditions | Max. Dev. |
|--------------------------------|-----------------------------|-----------|
| Storage temp. range | -55 to +125°C | |
| TA Operating temperature range | -40 to +85°C | |
| Shock resistance | ΔF/F 5000 g, 0.3 ms, ½ sine | ±5 ppm |
| Vibration resistance | ΔF/F 20 g / 10–2000 Hz | ±5 ppm |

TERMINATIONS AND PROCESSING

| Package | Termination | Processing |
|---------|-----------------|---|
| SON-10 | Au flashed pads | IPC/JEDEC J-STD-020C 260°C / 20 - 40 s |

FREQUENCY TEMPERATURE CHARACTERISTICS

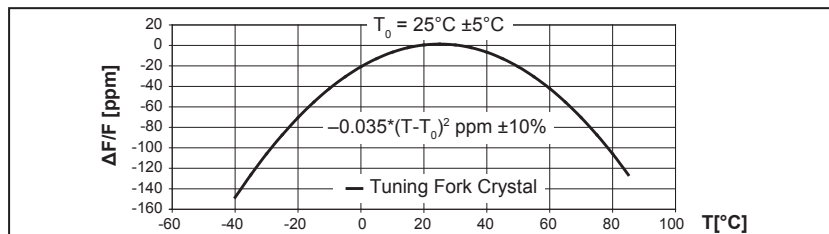

PIN CONNECTIONS TOP VIEW

| Pin | Connection |
|-----|--------------------------------------|
| 1 | V _{DD} Power Supply Voltage |
| 2 | CLKOUT Clock Output |
| 3 | SCL Serial Clock Input |
| 4 | SCI Serial Data Input |
| 5 | SDO Serial Data Output |
| 6 | V _{SS} Ground |
| 7 | CE Chip Enable |
| 8 | INT̄ Interrupt Output |
| 9 | NC Not connected |
| 10 | CLKOE Clock Output Enable |

ORDERING INFORMATION

| RV - 2123 - C2 TA QC |
|---|
| RTC module |
| Product type |
| Package size C2 = 5.0 x 3.2 x 1.2 mm |
| Qualification QC = Commercial Grade (Standard) QA = Automotive Grade AEC-Q200 |
| Temperature range TA = -40 to +85°C (Standard) |

A unique part number will be generated for each product specification, i.e.:

| | |
|-------------|---------------------------------------|
| 20xxxx-MG01 | 1'000 pcs (in 12 mm tape on 7" reel) |
| 20xxxx-PG05 | 5'000 pcs (in 12 mm tape on 13" reel) |

All specifications subject to change without notice.



A COMPANY OF THE SWATCH GROUP

Micro Crystal AG
Muehlestrasse 14
CH-2540 Grenchen
Switzerland

Phone +41 32 655 82 82
Fax +41 32 655 82 83
sales@microcrystal.com
www.microcrystal.com

X-ON Electronics

Largest Supplier of Electrical and Electronic Components

Click to view similar products for [Clock & Timer Development Tools](#) category:

Click to view products by [Micro Crystal](#) manufacturer:

Other Similar products are found below :

[AD9517-0A/PCBZ](#) [AD9517-2A/PCBZ](#) [AD9522-4/PCBZ](#) [AD9520-5PCBZ](#) [AD9530/PCBZ](#) [AD9553/PCBZ](#) [ADCLK914PCBZ](#)
[LMH2180SDEVAL](#) [DSC400-0333Q0032KE1-EVB](#) [TDGL013](#) [MAX2880EVKIT#](#) [MAX2750EVKIT](#) [MAX2752EVKIT](#) [ADCLK946PCBZ](#)
[ADCLK946/PCBZ](#) [MAX2622EVKIT](#) [EKIT01-HMC1032LP6G](#) [Si5332-8IX-EVB](#) [Si5332-12IX-EVB](#) [RV-3029-C2-EVALUATION-BOARD-](#)
[OPTION-B](#) [Si5332-6IX-EVB](#) [SKY72310-11-EVB](#) [EV1HMC8364LP6G](#) [RV-8263-C7-EVALUATION-BOARD](#) [EVK9FGV1002](#)
[EVK9FGV1008](#) [EV1HMC6832ALP5L](#) [EVAL01-HMC830LP6GE](#) [EVAL01-HMC911LC4B](#) [EVAL01-HMC988LP3E](#) [TS3002DB](#) [125605-](#)
[HMC702LP6CE](#) [LMX2487E-EVM](#) [MIKROE-2481](#) [2045](#) [EKIT01-HMC835LP6G](#) [EKIT01-HMC834LP6GE](#) [TS3006DB](#) [DSC-](#)
[TIMEFLASH2-KIT1](#) [110227-HMC510LP5](#) [110227-HMC513LP5](#) [AD9515/PCBZ](#) [ADCLK948/PCBZ](#) [ADCLK954/PCBZ](#) [112261-](#)
[HMC739LP4](#) [ADCLK925/PCBZ](#) [AD9522-0/PCBZ](#) [AD9520-4/PCBZ](#) [AC164147](#) [DFR0469](#)