

# DEVELOPMENT BOARD

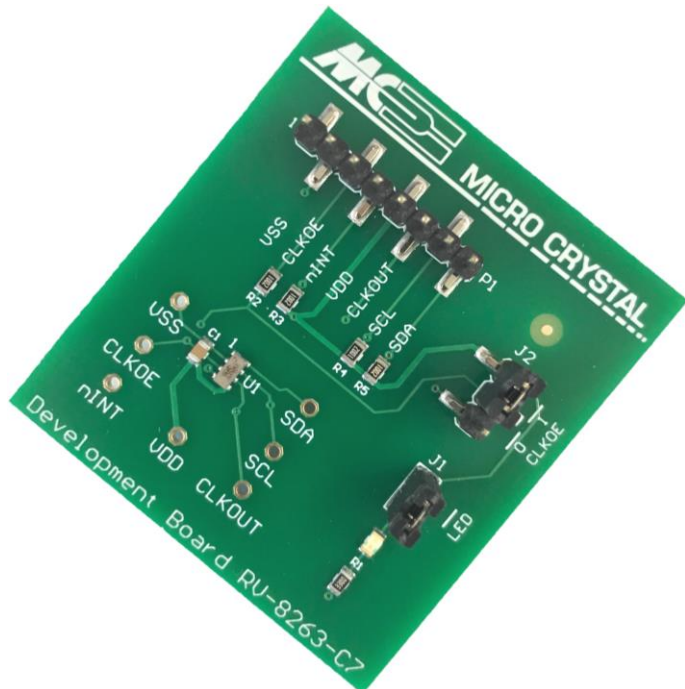

# RV-8263-C7

## Low-Power Real-Time Clock / Calendar Module

## RV-8263-C7

The RV-8263-C7 is soldered onto the Development Board.  
 Every pin is either accessible at test pins 1 – 8 or at the test vias situated around the device.

The following passive components are already soldered on the board:

C1	10 nF	Decoupling capacitor between V <sub>SS</sub> and V <sub>DD</sub>
R1	330 Ω	Current limiting resistor for LED
LED	green	Supply on, current consumption of the LED has to be considered
R2	10 kΩ	Protection resistor to prevent short-circuit between external CLKOE signal and Jumper
R3	10 kΩ	Pull-up resistor $\overline{\text{INT}}$ to V <sub>DD</sub>
R4	10 kΩ	Pull-up resistor SCL to V <sub>DD</sub>
R5	10 kΩ	Pull-up resistor SDA to V <sub>DD</sub>

### DEVELOPMENT BOARD

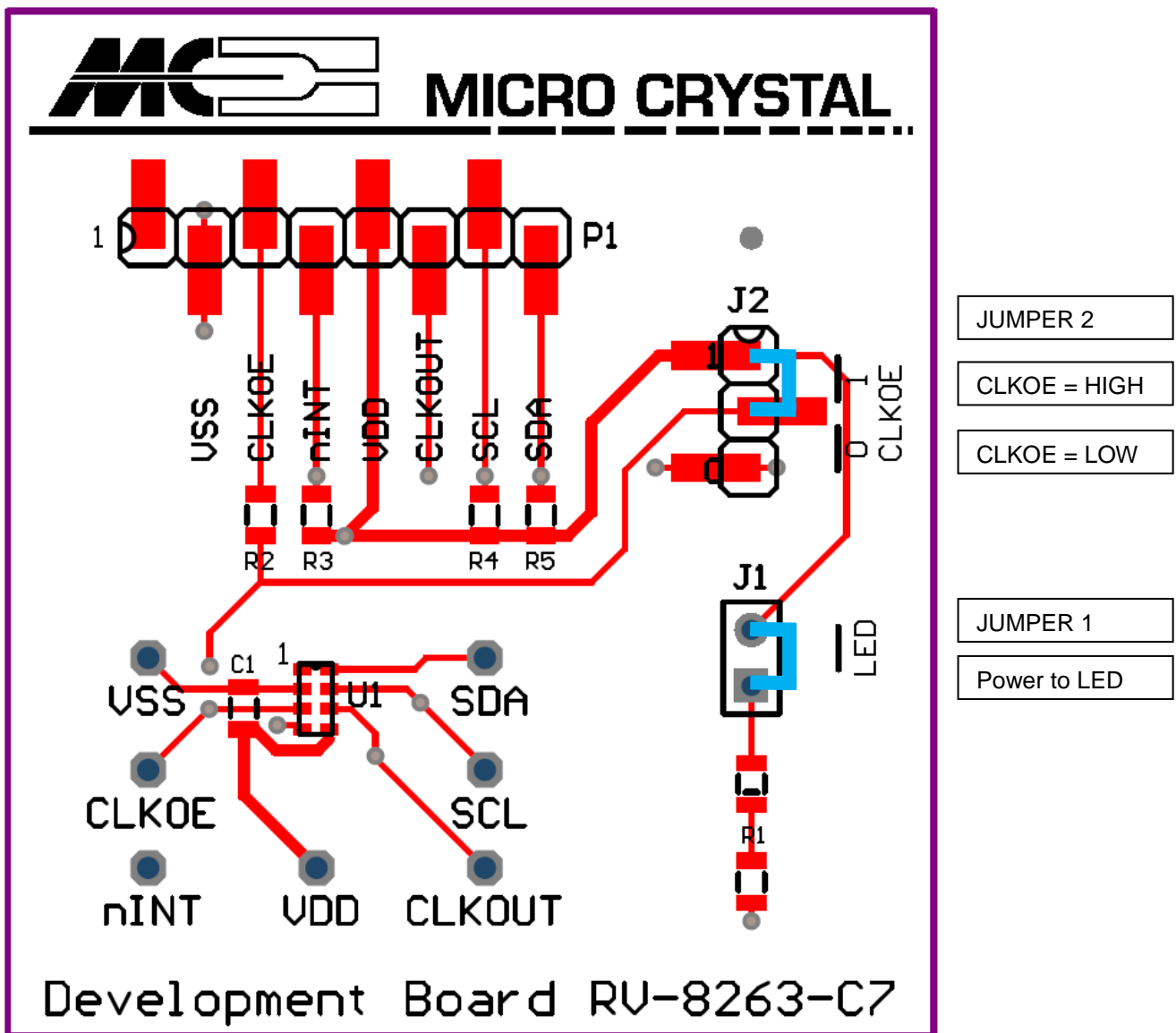

SCHEMATICS

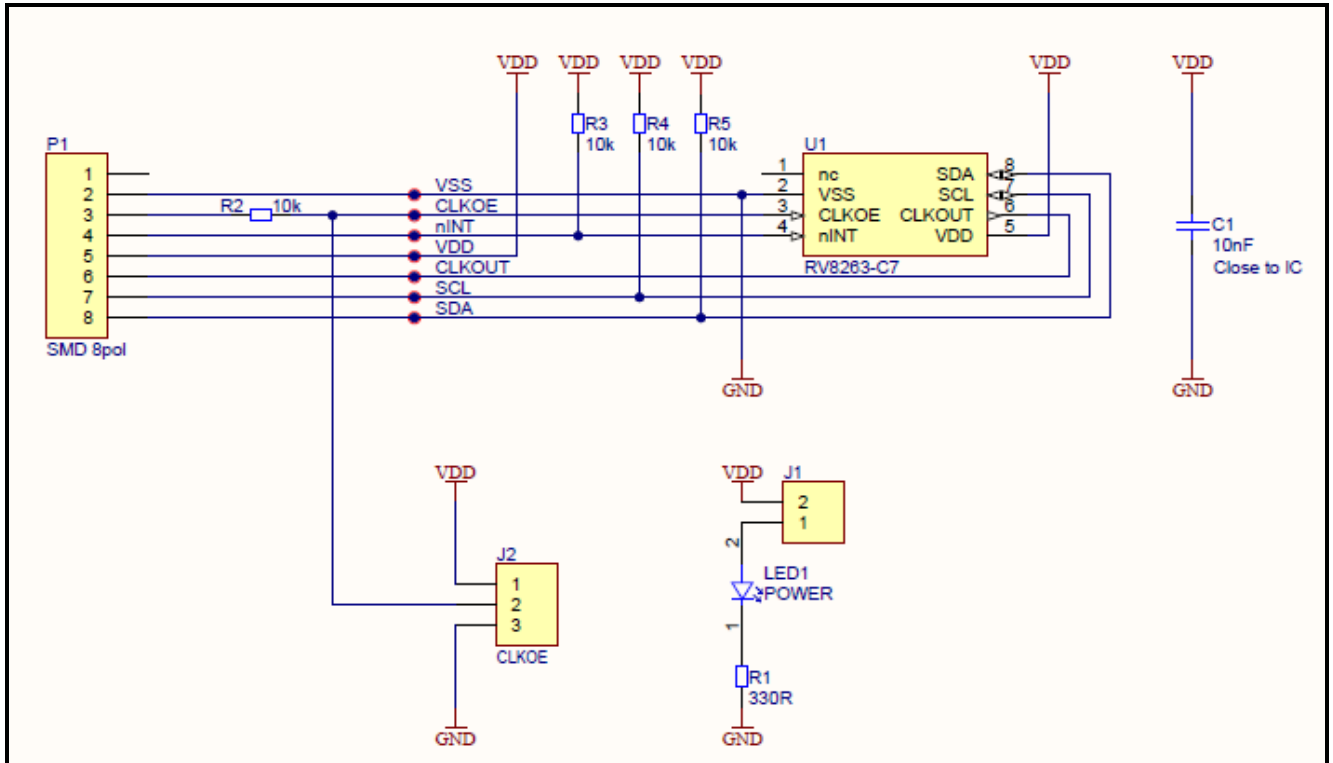

PINOUT RV-8263-C7

# 1	NC	# 8	SDA
# 2	V <sub>ss</sub>	# 7	SCL
# 3	CLKOE	# 6	CLKOUT
# 4	$\overline{\text{INT}}$	# 5	V <sub>DD</sub>

PIN DESCRIPTION

Symbol	Pin #	Description
NC	1	Not connected. Is internally connected and should be left floating.
V <sub>SS</sub>	2	Ground
CLKOE	3	Input to enable the CLKOUT pin. If CLKOE is HIGH, the CLKOUT pin is in output mode. When CLKOE is tied to Ground, the CLKOUT pin is LOW.
$\overline{\text{INT}}$	4	Interrupt Output; open-drain; active LOW; requires pull-up resistor; Used to output alarm, minute, half minute, countdown timer and compensation Interrupt signals
V <sub>DD</sub>	5	Power Supply Voltage
CLKOUT	6	Clock Output; push-pull; controlled by CLKOE. If CLKOE is active HIGH, the CLKOUT pin drives the square wave of 32.768 kHz, 16.384 kHz, 8.192 kHz, 4.096 kHz, 2.048 kHz, 1.024 kHz or 1 Hz (Default value is 32.768 kHz). When CLKOE is tied to Ground, the CLKOUT pin is LOW
SCL	7	I2C Serial Clock Input. Requires pull-up resistor.
SDA	8	I2C Serial Data Input-Output. Requires pull-up resistor.

Datasheet and Application-Manual are available for download under: [www.microcrystal.com](http://www.microcrystal.com)

## X-ON Electronics

Largest Supplier of Electrical and Electronic Components

*Click to view similar products for [Clock & Timer Development Tools](#) category:*

*Click to view products by [Micro Crystal](#) manufacturer:*

Other Similar products are found below :

[AD9517-0A/PCBZ](#) [AD9517-2A/PCBZ](#) [AD9522-4/PCBZ](#) [AD9520-5PCBZ](#) [AD9553/PCBZ](#) [ADCLK914PCBZ](#) [LMH2180SDEVAL](#) [DSC400-0333Q0032KE1-EVB](#) [TDGL013](#) [MAX2880EVKIT#](#) [MAX2750EVKIT](#) [MAX2752EVKIT](#) [ADCLK946PCBZ](#) [ADCLK946/PCBZ](#) [MAX2622EVKIT](#) [EKIT01-HMC1032LP6G](#) [Si5332-8IX-EVB](#) [RV-2251-C3-EVALUATION-BOARD](#) [Si5332-12IX-EVB](#) [RV-3029-C2-EVALUATION-BOARD-OPTION-B](#) [Si5332-6IX-EVB](#) [SKY72310-11-EVB](#) [EV1HMC8364LP6G](#) [RV-8263-C7-EVALUATION-BOARD](#) [EVK9FGV1002](#) [EVK9FGV1008](#) [EV1HMC6832ALP5L](#) [EVAL01-HMC830LP6GE](#) [EVAL01-HMC911LC4B](#) [TS3002DB](#) [125605-HMC702LP6CE](#) [LMX2487E-EVM](#) [MIKROE-2481](#) [2045](#) [EKIT01-HMC835LP6G](#) [EKIT01-HMC834LP6GE](#) [TS3006DB](#) [DSC-TIMEFLASH2-KIT1](#) [110227-HMC510LP5](#) [110227-HMC513LP5](#) [AD9515/PCBZ](#) [ADCLK948/PCBZ](#) [ADCLK954/PCBZ](#) [112261-HMC739LP4](#) [ADCLK925/PCBZ](#) [AD9522-0/PCBZ](#) [AD9520-4/PCBZ](#) [AC164147](#) [DFR0469](#) [LMK04133EVAL/NOPB](#)