

仕样书编号 NO.: QW-QA-332 REV1.2

CUSTOMER: \_\_\_\_\_

日期 DATE: \_\_\_\_\_

# 纳入仕样书 SPECIFICATION

产品名称 PRODUCT NAME: 叠层片式天线

Multilayer Chip Antenna

贵司料号 YOUR PART NO.: \_\_\_\_\_

敝司料号 OUR PART NO.: MGMA5220H2450-A04

接受 RECEPTION THE SPECIFICATION HAS BEEN ACCEPTED. 该纳入仕样书已被我司接受  <div style="display: flex; justify-content: space-between;"> <div style="text-align: right;">           公司: COMPANY:         </div> <div style="text-align: left;">           日期: DATE:         </div> </div>		
批准 CFMD	审核 CHKD	接收 RCVD

本纳入仕样书共 13 页

MANUFACTURING NAME

深圳市麦捷微电子科技股份有限公司  
 SHENZHEN MICROGATE TECHNOLOGY CO., LTD  
 TEL: 86-755-28085000  
 FAX: 86-755-28085605

CFMD. 批准	CHKD. 审核	DSGD. 担当
罗盛滔	胡潞乐	曾艳锋

# 目录 CATALOG

1 适用范围 Scope.....	3
2 品名构成 Product Identification.....	3
3 形状、尺寸 Appearance and Dimensions.....	3
4 测试电路 Test Circuit.....	3
5 电气性能 Electrical Characteristics.....	4
6 特性曲线 Characteristic curve.....	4
7 方向图 Radiation Pattern.....	5
8 信赖性试验 Reliable Performance.....	6
9 焊接条件 Recommended Soldering Conditions.....	8
10 包装 Packaging.....	9
11 装箱清单及标志 Packing documents and marking.....	10
12 保管 Storage.....	12
<b>APPENDIX A</b>	
纳入仕様书改定履历 Modify History of Specification .....	13

## 1 适用范围 Scope

"麦捷"叠层片式天线 MGMA 系列产品，设计用于 WLAN、蓝牙天线、PHS，手机多频天线，GPS 等小体积 SMD 片式设计。

"Microgate" Multilayer Chip Antenna series are designed to be used in WLAN、Bluetooth、PHS、Multiple-band Mobile phone antenna, GPS, etc and compact size SMD chip design.

## 2 品名构成 Product Identification

MGMA 5220 H 2450 -A04

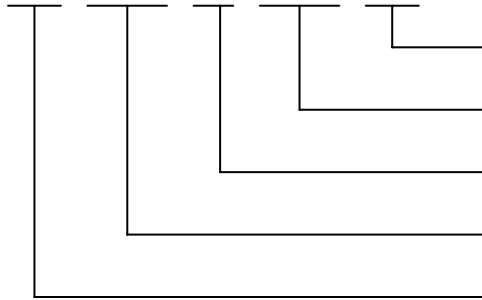

产品名称，编号 A01/Normaling Type: A04

中心频率/ Center Frequency: 2450MHz

结构系列/Structure Series

产品尺寸/Size: 5.2×2.0×1.1

多层结构天线/Multi-layer Antenna

## 3 形状、尺寸 Appearance and Dimensions

(Unit: mm)

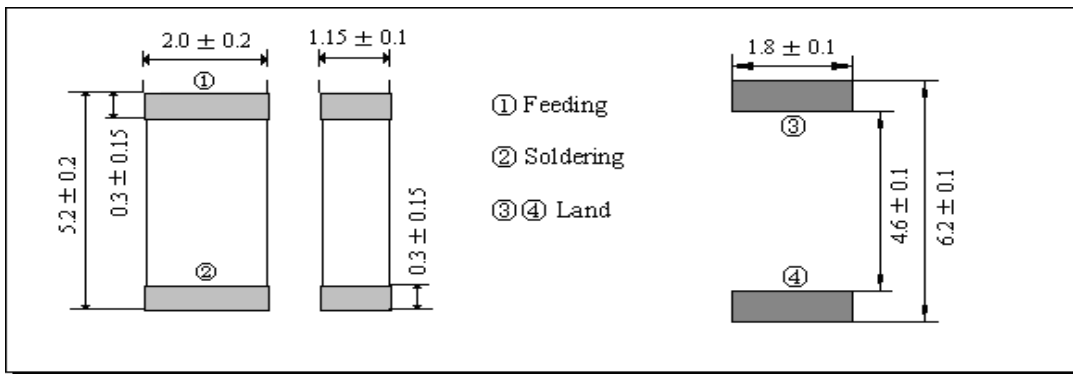

## 4 测试电路 Test Circuit

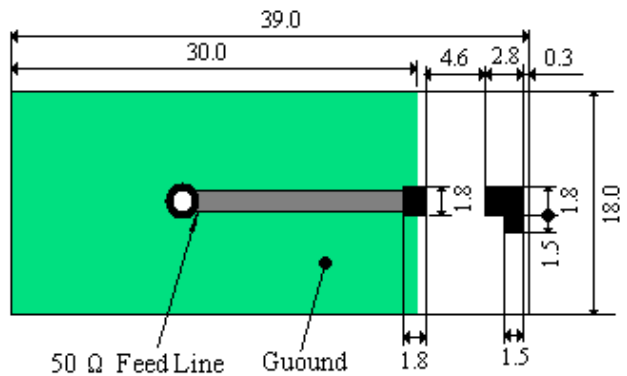
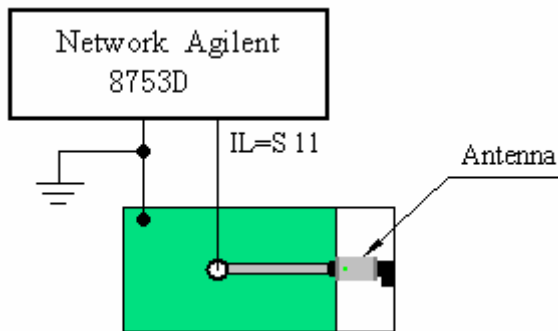

深圳市麦捷微电子科技股份有限公司

地址：深圳市宝安区观澜镇高尔夫大道裕兴路

电话(Tel): 0755-28085000

传真(Fax): 0755-28085605

邮编(Postcode): 518110

3

## 5 电气性能 Electrical Characteristics

操作温度范围 Operating Temperature Range : -40 to +85°C

保存温度范围 Storage Temperature Range : -40 to +85°C

No.	Item (项目)	Specifications (特性)
5.1	Working Central Frequency 中心工作频率	2450 MHz
5.2	Band Width 通带宽度	±75 MHz ( 2375~2525MHz )
5.3	Gain 增益	0~2 dBi
5.4	V.S.W.R (in BW) 驻波比	≤2.0
5.5	Polarization 极化方式	Linear 线性
5.6	Azimuth Beam width 方位角	Omni-directional 全向
5.7	Impedance 阻抗	50 Ω

\*本天线在应用 PCB 上通过设计匹配电路，将天线工作频率调整到 2.45GHz 中心工作频率。

## 6 特性曲线 Characteristic curve



深圳市麦捷微电子科技股份有限公司

地址：深圳市宝安区观澜镇高尔夫大道裕兴路

电话(Tel): 0755-28085000

传真(Fax): 0755-28085605

邮编(Postcode): 518110

4

## 7 方向图 Radiation Pattern

XY-V/XY-H

XY cut @2.45GHz  
 — Vertical  
 - - - Horizontal

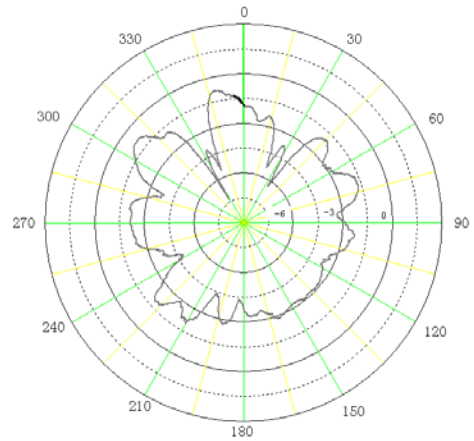
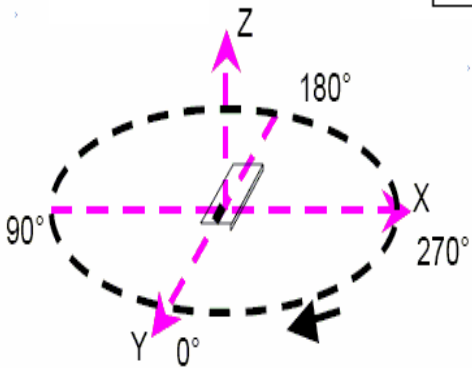

XZ-V/XZ-H

XZ cut @2.45GHz  
 — Vertical  
 - - - Horizontal

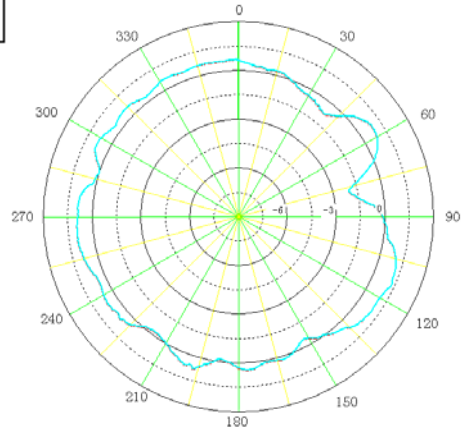
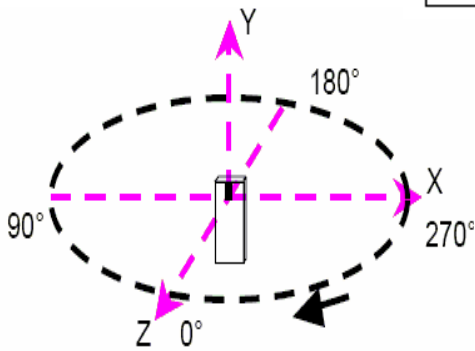

YZ-V/YZ-H

XZ cut @2.45GHz  
 — Vertical  
 - - - Horizontal

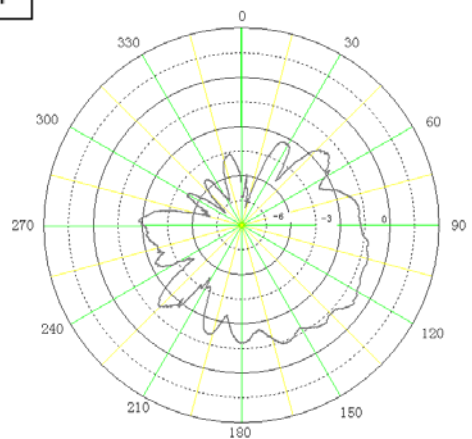
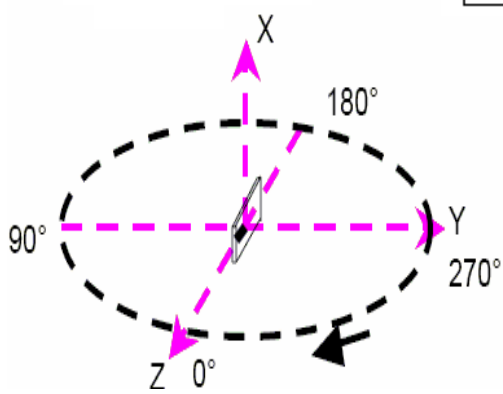

## 8 信赖性试验 Reliable Performance

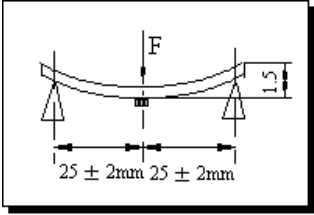
NO.	Item	Specifications	Test Methods	
7-1	Solder-Ability 可焊性	More than 90% of termination should be covered with new solder. 端电极焊锡覆盖率为90%以上。	焊锡 Solder: Sn: Pb=	100:0
			焊锡温度 Temperature:	255°C+5°C/-0°C
			助焊剂 Flux: 松香 rosin	
			浸渍时间 Duration:	5±0.5s
7-2	Leaching Resistance 耐焊性	More than 75% of termination Should be covered with new solder. 端电极焊锡覆盖率为75%以上	焊锡 Solder: Sn: Pb=	100:0
			焊锡温度 Temperature:	270°C+2°C/-0°C
			助焊剂 Flux: 松香 rosin	
			浸渍时间 Duration:	10±0.5s
7-3	Terminal Strength 端头强度	The terminal and body should be no damage 端头和瓷体不应见损伤	The device should not be broken after tensile force of 1.0kg is slowly applied to pull a lead pin of the fixed device in the lead axis direction for 10±1 seconds. 在产品电极端子上或表面上应能承受 1kg 垂直拉力 10±1 秒	
7-4	Bending Strength 弯曲试验	No mechanical damage should be noticed 不应见机械损伤	<p>Weld the product to the center part of the PCB with the thickness 1.6±0.2mm as the illustration shows, and keep exerting force arrow-ward on it at speed of: 1mm/S, and hold for 5±1S at the position of 1.5mm bending distance, so far, any peeling off of the product metal coating should not be detected.</p> <p>将产品按图焊在 1.6±0.2mm 的 PCB 板中间, 由箭头方向施力 1mm/S, 弯曲距离 1.5mm, 保持 5±1S, 产品金属层无脱落。</p> 	

NO.	Item	Specifications	Test Methods	
7-5	Drop 跌落	Post Environmental Tolerance (环境试验后允许附加误差)	Drop 10 times on a concrete floor from a height of 1m. 从距混凝土地面 1m 高度自由落下, 重复 3 次。	
7-6	Vibration 振动		频率 Frequency: 10 to 55Hz 振幅 Amplitude: 1.5mm 方向及时间 Direction and time: X, Y and Z directions for 2 hours each.	
7-7	Humidity resistance 耐潮湿		a. 试验条件 Test condition 温度 Temp.: 60±2℃ 湿度 Humidity: 90%~95% 试验时间 Test time: 96±2 h b. 测量条件 Measurement method: 试验后常温常湿环境中放置 (24±2) 小时后测量。 The component should be stabilized at normal condition for (24±2) hours before test.	
7-8	High temperature resistance 耐高温		1 Center Frequency 中心频率: ±25 MHz; 2 Band Width 通带宽度: ±20 MHz; 3 Gain 增益: ±0.2 dBi 4 V.S.W.R (in BW) 驻波比: ±0.5 dB;	a. 试验条件 Test condition 温度 Temp.: + 85±2℃ 试验时间 Test time: 96±2 h b. 测量条件 Measurement method: 试验后常温常湿环境中放置 (24±2) 小时后测量。 The component should be stabilized at normal condition for (24±2) hours before test.
7-9	Low temperature resistance 耐低温		a. 试验条件 Test condition 温度 Temp.: -40±2℃ 试验时间 Test time: 96±2 h b. 测量条件 Measurement method: 试验后常温常湿环境中放置 (24±2) 小时后测量。 The component should be stabilized at normal condition for (24±2) hours before test.	
7-10	Thermal shock (Temperature cycle) 热冲击 (温度循环)		a. 试验条件 Test condition 1) 温度 Temp.: -40℃, 时间 time: 30±3min 2) 温度 Temp.: +85℃, 时间 time: 30±3min 5 cycles b. 测量条件 Measurement method: 试验后常温常湿环境中放置 (24±2) 小时后测量。 The component should be stabilized at normal condition for (24±2) hours before test.	

## 9 焊接条件 Recommended Soldering Conditions

### 1、焊剂 Flux, Solder

① 使用松香助焊剂，禁止使用卤化物含量超过 0.2wt% 的强酸性助焊剂。

Use rosin-based flux. Don't use highly acidic flux with halide content exceeding 0.2wt% (chlorine conversion value).

② 使用纯锡焊料 Use Sn solder.

### 2、回流焊条件 Reflow soldering conditions

● 预热时，产品表温与焊料温度的温差最大不允许超出 150℃，焊接完后冷却时，产品表温与溶剂温度之间的温差最大不允许超出 100℃。预热不足有可能引发产品表面裂纹，导致产品品质下降。

Pre-heating should be in such a way that the temperature difference between solder and product surface is limited to 150℃ max. Cooling into solvent after soldering also should be in such a way that temperature difference is limited to 100℃ max. Unwrought pre-heating may cause cracks on the product, resulting in the deterioration of products quality.

● 标准回流焊曲线 Standard soldering profile.

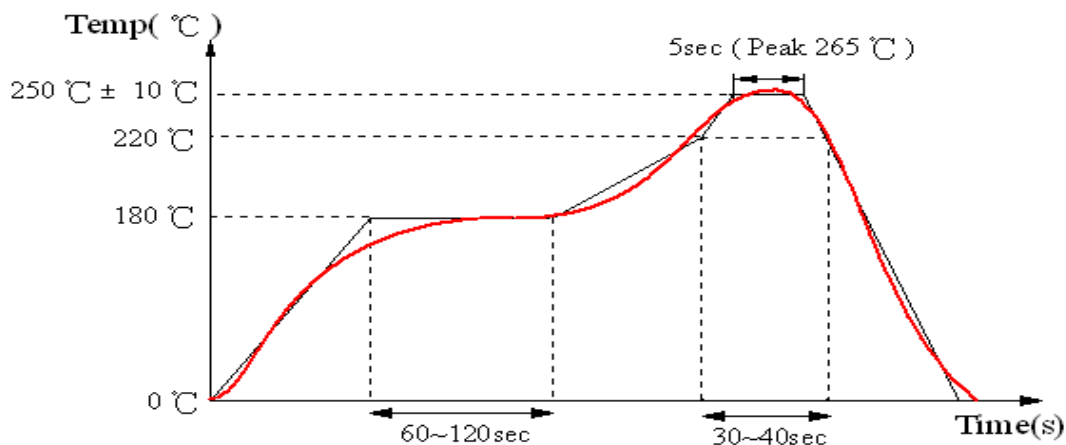

### 3、手工返工 Reworking with soldering iron

当使用电烙铁进行手工焊接时，以下条件必须严格遵守 The following conditions must be strictly followed when using a soldering iron.

预热 Pre-heating	150°C, 1 minute
尖端温度 Tip temperature	350°C max
输出功率 Soldering iron output	80w max
电烙铁头尖端尺寸 End of soldering iron	φ3mm max
焊接时间 Soldering time	3 seconds max



## 10 包装 Packaging

### ① 编带尺寸 Dimensions of Tape:

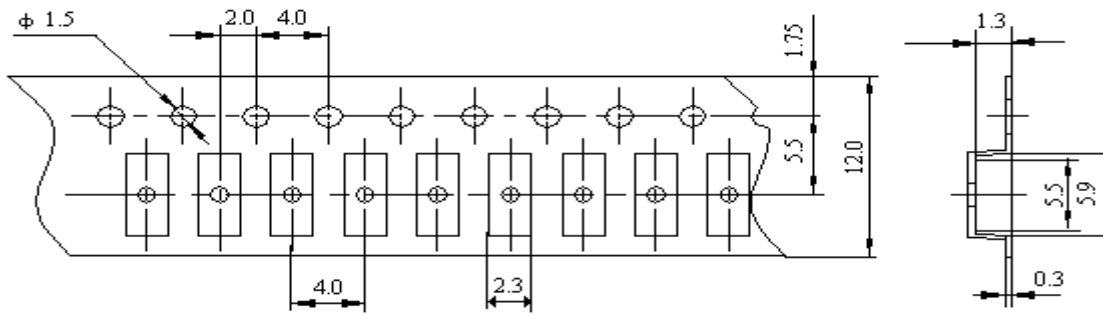

### ② 带轮尺寸 Dimensions of Reel

Unit: mm

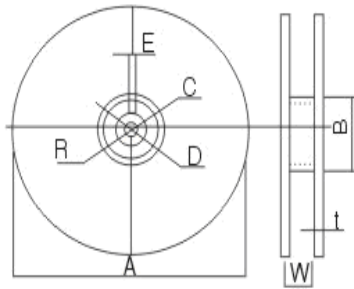

Reel material: PS (Polystyrene)

A	178±2
B	60±2
C	13.0±0.5
D	21.0±0.8
E	2.0±0.5
W	12.5±1.5
t	1.2±0.2
R	1.0±0.25

### ③ 编带抗拉强度 Pulling strength of tapes:

载带 Carrier tape	10N or more (1kgf or more)
上盖带 Cover tape	5N or more (1kgf or more)

### ④ 编带简图及拉伸方向 Taping figure and drawing direction:

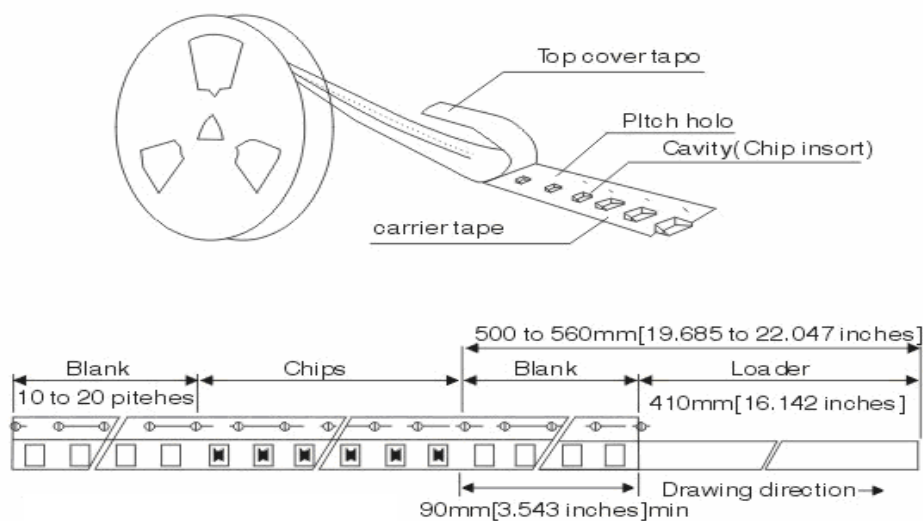

深圳市麦捷微电子科技股份有限公司

地址: 深圳市宝安区观澜镇高尔夫大道裕兴路

电话(Tel): 0755-28085000

传真(Fax): 0755-28085605

邮编(Postcode): 518110

9

⑤ 盖带的剥离强度 Peeling strength of cover tape:

盖带 Cover tape	0.3~0.7N (30gf~70gf)
---------------	----------------------

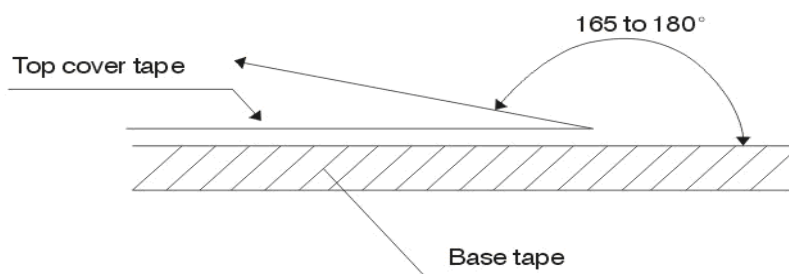

测试条件 Test condition:

- 1) 剥离角度 peel angle: 165°~180° vs. carrier tape.
- 2) 剥离速度 peel speed: 300mm/min±10%.

⑥ 包装数量 Packaging quantities: 3000 PCS / Reel

## 11 装箱清单及标志 Packing documents and marking

### 1. 包装文件 Packing documents

Packing includes the following:

- a. 装箱清单 Packing list.
- b. 合格证书 Certificate of compliance.

### 2. 盘上标记 Marking on reels:

- a 麦捷料号 MICROGATE Part No.
- b 生产批号 Lot number
- c 盘装数量 Quantity per reel
- d 检验员号 Inspector No.

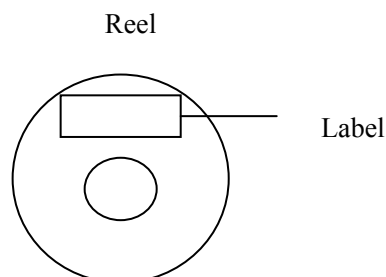

以上内容必须在标签上注明.All above shall be shown on marking label

麦捷公司标签如下所示: MICROGATE marking label will be as following:

MICROGATE		
CUSTOMER:	P. O. NO	
CUSTOMER PART NO:	DATE CODE	LOT NO
MG PART NO:	QUANTITY	INSP. NO



**MG PART NO**

深圳市麦捷微电子科技股份有限公司

地址: 深圳市宝安区观澜镇高尔夫大道裕兴路

电话(Tel): 0755-28085000

传真(Fax): 0755-28085605

邮编(Postcode): 518110

检验合格后,检验员在标签上盖上合格章。合格章如下所示: The eligible reels will be pressed a mark onto the surface. The mark will be as following:

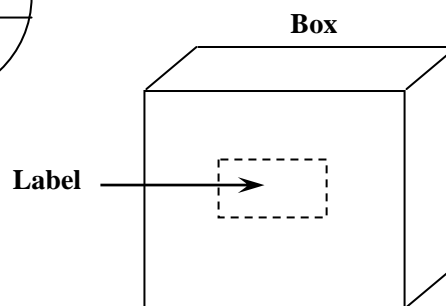
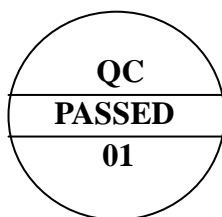

3. 内包装盒标记:Marking on inner box

- a. 型号 MICROGATE part No.
- b. 每盒数量 Quantity per box
- c. 包装日期 Date

以上内容必须在标签上注明(标签见 11.2 所示)。Above shall be shown on marking label (The marking label is shown in item 9.2).

4. 外包装箱标记 Marking on outer case:

- 1) 制造商 Manufacturer: “MICROGATE” ①

“中国深圳制造” “Made in Shenzhen CHINA”②

- 2) 发运标记 Ship marking:

“向上” “UP”, “小心轻放”“HAND CARE”, “防潮”“MOISTURE-PROOF”.

- 3) 包装标签包括以下内容 Packing label include the following:

- a. 型号 MICROGATE Part No
- b. 总数量 Total quantity per case
- c. 包装日期 Date;

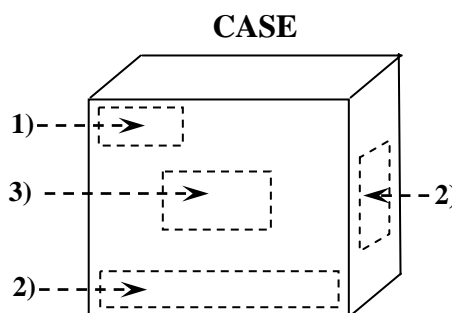

以上内容必须在标签上注明。(参见 11.2 所示)

All above shall be shown on marking label.

(The marking label is shown in item 11.2)

## 12 保管 Storage

### ①. 保管期限 Storage period

距麦捷出厂检验时间六个月内，产品可以使用；检验时间可以通过包装外侧标记的检验号确认；若时间超出六个月，应检查焊接性能后方可使用。Products which inspected in MICROGATE over 6 months ago should be examined and used, which can be confirmed with inspection No. marked on the container. Solder ability should be checked if this period is exceeded.

### ②. 保存条件 Storage conditions

●存放货物的库房应满足以下条件 Products should be storage in the warehouse on the following conditions

温度 Temperature:  $\leq 40^{\circ}\text{C}$

湿度 Humidity :  $\leq 70\%$  relative humidity

不允许温、湿度有极剧变化。No rapid change on temperature and humidity

●禁止将产品保管在腐蚀性物质中，例如硫磺、氯气或者酸，否则将引起端头氧化，导致降低焊接性。Don't keep products in corrosive gases such as sulfur, chlorine gas or acid, or it may cause oxidization of electrode, resulting in poor solder ability.

●为了避免受潮气、灰尘等物质的影响，产品应保管于货架上。Products should be storage on the palette for the prevention of the influence from humidity, dust and so on.

●产品保管在库房中时，应避免热冲击，振动以及直接光照等等。Products should be storage in the warehouse without heat shock, vibration, and direct sunlight and so on.

●产品应密封包装 Products should be storage under the airtight packaged condition.

**APPENDIX A**

**纳入仕様书改定履历 MODIFY HISTORY OF SPECIFICATION**

NO.	DATE	CONTENT	REV	APPROVED
1	2006-10-25	初稿 Constitute	1.0	张海恩
2	2007.12.01	修改 MARK 标识 Update the mark pattern	1.1	张海恩
3	2009.03.31	删除 MARK 标识 Delete the mark pattern	1.2	张海恩

## Test Report

No. : CE/2011/72710 Date : 2011/07/19 Page : 1 of 7

SHENZHEN MICROGATE TECHNOLOGY., LTD.  
YUXING ROAD, GOLF STREET, GUANLAN TOWN, BAO'AN DISTRICT, SHENZHEN



The following sample(s) was/were submitted and identified by/on behalf of the client as:

Sample Description : MULTILAYER CHIP CERAMIC RF COMPONENTS  
SGS Ref No. : SZ13231280-6.1  
Sample Receiving Date : 2011/07/13  
Testing Period : 2011/07/13 TO 2011/07/19

=====  
Test Result(s) : Please refer to next page(s).

  
  
Chenyu Kung / Operation Manager  
Signed for and on behalf of  
SGS TAIWAN LTD.  
Chemical Laboratory – Taipei

Unless otherwise stated the results shown in this test report refer only to the sample(s) tested. This test report cannot be reproduced, except in full, without prior written permission of the Company. 除非另有說明，此報告結果僅對測試的樣品負責。本報告未經本公司書面許可，不可部份複製。  
This document is issued by the Company subject to its General Conditions of Service printed overleaf, available on request or accessible at [www.sgs.com/terms\\_and\\_conditions.htm](http://www.sgs.com/terms_and_conditions.htm) and, for electronic format documents, subject to Terms and Conditions for Electronic Documents at [www.sgs.com/terms\\_e-document.htm](http://www.sgs.com/terms_e-document.htm). Attention is drawn to the limitation of liability, indemnification and jurisdiction issues defined therein. Any holder of this document is advised that information contained hereon reflects the Company's findings at the time of its intervention only and within the limits of Client's instructions, if any. The Company's sole responsibility is to its Client and this document does not exonerate parties to a transaction from exercising all their rights and obligations under the transaction documents. This document cannot be reproduced except in full, without prior written approval of the Company. Any unauthorized alteration, forgery or falsification of the content or appearance of this document is unlawful and offenders may be prosecuted to the fullest extent of the law.

# Test Report

No. : CE/2011/72710 Date : 2011/07/19 Page : 2 of 7

SHENZHEN MICROGATE TECHNOLOGY., LTD.  
YUXING ROAD, GOLF STREET, GUANLAN TOWN, BAO'AN DISTRICT, SHENZHEN



## Test Result(s)

PART NAME No.1 : MIXED ALL PARTS (FIVE TYPES)

Test Item (s):	Unit	Method	MDL	Result
				No.1
Cadmium (Cd)	mg/kg	With reference to IEC 62321: 2008 and performed by ICP-AES.	2	n.d.
Lead (Pb)	mg/kg	With reference to IEC 62321: 2008 and performed by ICP-AES.	2	14
Mercury (Hg)	mg/kg	With reference to IEC 62321: 2008 and performed by ICP-AES.	2	n.d.
Hexavalent Chromium Cr(VI) by alkaline extraction	mg/kg	With reference to IEC 62321: 2008 and performed by UV-VIS.	2	n.d.
<b>Sum of PBBs</b>	mg/kg	With reference to IEC 62321: 2008 and performed by GC/MS.	-	n.d.
Monobromobiphenyl			5	n.d.
Dibromobiphenyl			5	n.d.
Tribromobiphenyl			5	n.d.
Tetrabromobiphenyl			5	n.d.
Pentabromobiphenyl			5	n.d.
Hexabromobiphenyl			5	n.d.
Heptabromobiphenyl			5	n.d.
Octabromobiphenyl			5	n.d.
Nonabromobiphenyl			5	n.d.
Decabromobiphenyl			5	n.d.
<b>Sum of PBDEs</b>			-	n.d.
Monobromodiphenyl ether			5	n.d.
Dibromodiphenyl ether			5	n.d.
Tribromodiphenyl ether			5	n.d.
Tetrabromodiphenyl ether			5	n.d.
Pentabromodiphenyl ether			5	n.d.
Hexabromodiphenyl ether			5	n.d.
Heptabromodiphenyl ether			5	n.d.
Octabromodiphenyl ether			5	n.d.
Nonabromodiphenyl ether			5	n.d.
Decabromodiphenyl ether			5	n.d.

Unless otherwise stated the results shown in this test report refer only to the sample(s) tested. This test report cannot be reproduced, except in full, without prior written permission of the Company. 除非另有說明，此報告結果僅對測試的樣品負責。本報告未經本公司書面許可，不可部份複製。  
This document is issued by the Company subject to its General Conditions of Service printed overleaf, available on request or accessible at [www.sgs.com/terms\\_and\\_conditions.htm](http://www.sgs.com/terms_and_conditions.htm) and, for electronic format documents, subject to Terms and Conditions for Electronic Documents at [www.sgs.com/terms\\_e-document.htm](http://www.sgs.com/terms_e-document.htm). Attention is drawn to the limitation of liability, indemnification and jurisdiction issues defined therein. Any holder of this document is advised that information contained hereon reflects the Company's findings at the time of its intervention only and within the limits of Client's instructions, if any. The Company's sole responsibility is to its Client and this document does not exonerate parties to a transaction from exercising all their rights and obligations under the transaction documents. This document cannot be reproduced except in full, without prior written approval of the Company. Any unauthorized alteration, forgery or falsification of the content or appearance of this document is unlawful and offenders may be prosecuted to the fullest extent of the law.

# Test Report

No. : CE/2011/72710 Date : 2011/07/19 Page : 3 of 7

SHENZHEN MICROGATE TECHNOLOGY., LTD.  
YUXING ROAD, GOLF STREET, GUANLAN TOWN, BAO'AN DISTRICT, SHENZHEN



Test Item (s):	Unit	Method	MDL	Result
				No.1
<b>Halogen</b>				
Halogen-Fluorine (F) (CAS No.: 14762-94-8)	mg/kg	With reference to BS EN 14582:2007. Analysis was performed by IC.	50	n.d.
Halogen-Chlorine (Cl) (CAS No.: 22537-15-1)			50	n.d.
Halogen-Bromine (Br) (CAS No.: 10097-32-2)			50	n.d.
Halogen-Iodine (I) (CAS No.: 14362-44-8)			50	n.d.

**Note :**

1. mg/kg = ppm ; 0.1wt% = 1000ppm
2. n.d. = Not Detected
3. MDL = Method Detection Limit
4. " - " = Not Regulated
5. The sample(s) was/were analyzed on behalf of the applicant as mixing sample in one testing. The above result(s) was/were only given as the informality value.

Unless otherwise stated the results shown in this test report refer only to the sample(s) tested. This test report cannot be reproduced, except in full, without prior written permission of the Company. 除非另有說明，此報告結果僅對測試的樣品負責。本報告未經本公司書面許可，不可部份複製。  
This document is issued by the Company subject to its General Conditions of Service printed overleaf, available on request or accessible at [www.sgs.com/terms\\_and\\_conditions.htm](http://www.sgs.com/terms_and_conditions.htm) and, for electronic format documents, subject to Terms and Conditions for Electronic Documents at [www.sgs.com/terms\\_e-document.htm](http://www.sgs.com/terms_e-document.htm). Attention is drawn to the limitation of liability, indemnification and jurisdiction issues defined therein. Any holder of this document is advised that information contained hereon reflects the Company's findings at the time of its intervention only and within the limits of Client's instructions, if any. The Company's sole responsibility is to its Client and this document does not exonerate parties to a transaction from exercising all their rights and obligations under the transaction documents. This document cannot be reproduced except in full, without prior written approval of the Company. Any unauthorized alteration, forgery or falsification of the content or appearance of this document is unlawful and offenders may be prosecuted to the fullest extent of the law.



## Test Report

No. : CE/2011/72710 Date : 2011/07/19 Page : 4 of 7

SHENZHEN MICROGATE TECHNOLOGY., LTD.

YUXING ROAD, GOLF STREET, GUANLAN TOWN, BAO'AN DISTRICT, SHENZHEN



- 1) These samples were dissolved totally by pre-conditioning method according to below flow chart.  
(Cr<sup>6+</sup> test method excluded)
- 2) Name of the person who made measurement: Climbgreat Yang
- 3) Name of the person in charge of measurement: Troy Chang

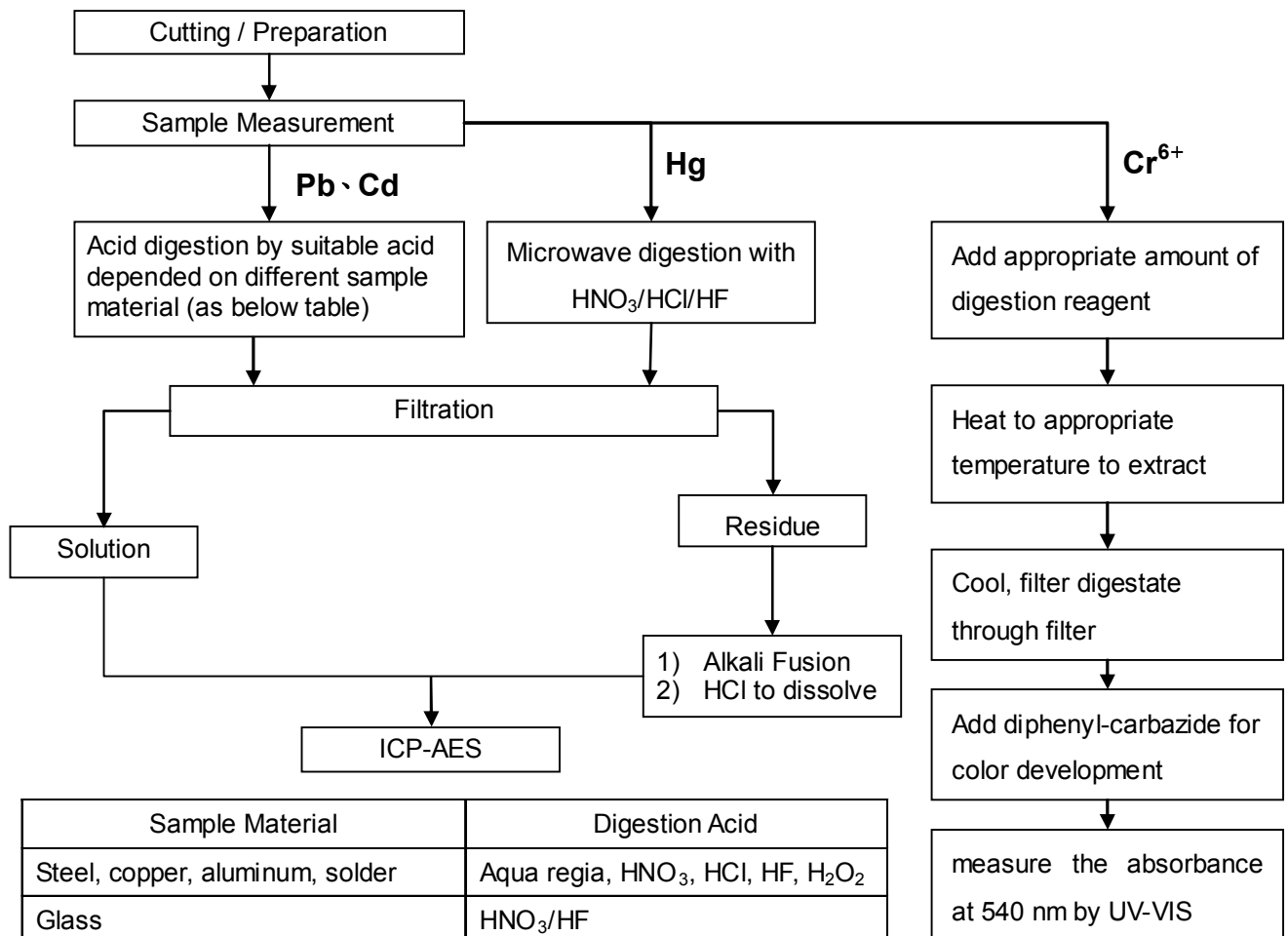

Sample Material	Digestion Acid
Steel, copper, aluminum, solder	Aqua regia, HNO <sub>3</sub> , HCl, HF, H <sub>2</sub> O <sub>2</sub>
Glass	HNO <sub>3</sub> /HF
Gold, platinum, palladium, ceramic	Aqua regia
Silver	HNO <sub>3</sub>
Plastic	H <sub>2</sub> SO <sub>4</sub> , H <sub>2</sub> O <sub>2</sub> , HNO <sub>3</sub> , HCl
Others	Any acid to total digestion

Unless otherwise stated the results shown in this test report refer only to the sample(s) tested. This test report cannot be reproduced, except in full, without prior written permission of the Company. 除非另有說明，此報告結果僅對測試的樣品負責。本報告未經本公司書面許可，不可部份複製。  
This document is issued by the Company subject to its General Conditions of Service printed overleaf, available on request or accessible at [www.sgs.com/terms\\_and\\_conditions.htm](http://www.sgs.com/terms_and_conditions.htm) and, for electronic format documents, subject to Terms and Conditions for Electronic Documents at [www.sgs.com/terms\\_e-document.htm](http://www.sgs.com/terms_e-document.htm). Attention is drawn to the limitation of liability, indemnification and jurisdiction issues defined therein. Any holder of this document is advised that information contained hereon reflects the Company's findings at the time of its intervention only and within the limits of Client's instructions, if any. The Company's sole responsibility is to its Client and this document does not exonerate parties to a transaction from exercising all their rights and obligations under the transaction documents. This document cannot be reproduced except in full, without prior written approval of the Company. Any unauthorized alteration, forgery or falsification of the content or appearance of this document is unlawful and offenders may be prosecuted to the fullest extent of the law.

## Test Report

No. : CE/2011/72710 Date : 2011/07/19 Page : 5 of 7

SHENZHEN MICROGATE TECHNOLOGY., LTD.  
YUXING ROAD, GOLF STREET, GUANLAN TOWN, BAO'AN DISTRICT, SHENZHEN



### PBB/PBDE analytical FLOW CHART

- 1) Name of the person who made measurement: Roman Wong
- 2) Name of the person in charge of measurement: Troy Chang

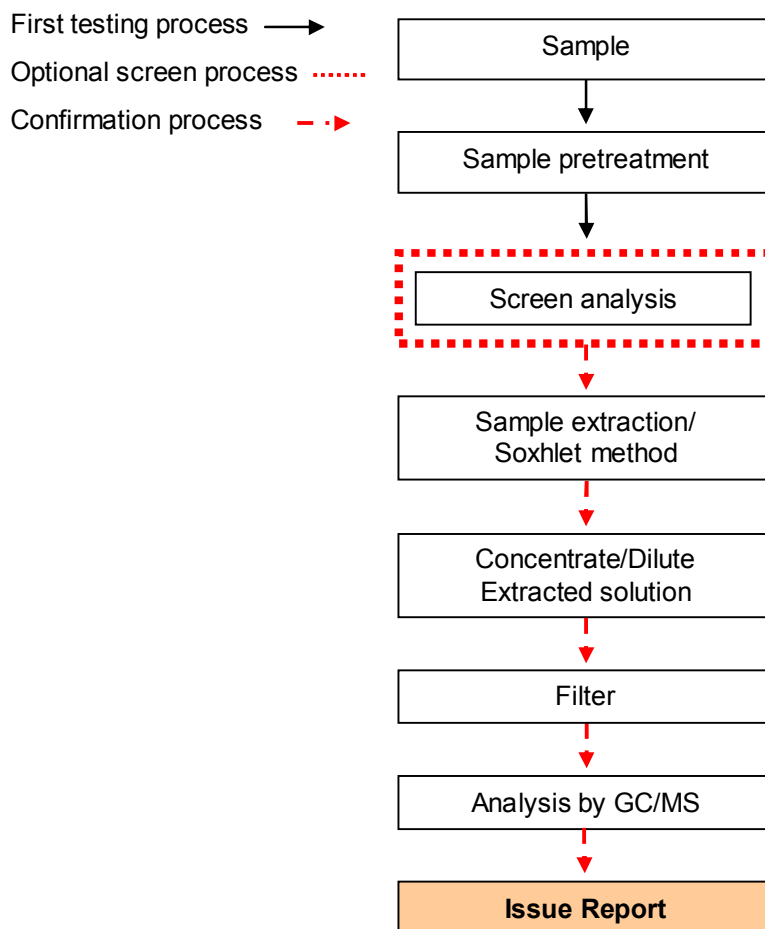

Unless otherwise stated the results shown in this test report refer only to the sample(s) tested. This test report cannot be reproduced, except in full, without prior written permission of the Company. 除非另有說明，此報告結果僅對測試的樣品負責。本報告未經本公司書面許可，不可部份複製。  
This document is issued by the Company subject to its General Conditions of Service printed overleaf, available on request or accessible at [www.sgs.com/terms\\_and\\_conditions.htm](http://www.sgs.com/terms_and_conditions.htm) and, for electronic format documents, subject to Terms and Conditions for Electronic Documents at [www.sgs.com/terms\\_e-document.htm](http://www.sgs.com/terms_e-document.htm). Attention is drawn to the limitation of liability, indemnification and jurisdiction issues defined therein. Any holder of this document is advised that information contained hereon reflects the Company's findings at the time of its intervention only and within the limits of Client's instructions, if any. The Company's sole responsibility is to its Client and this document does not exonerate parties to a transaction from exercising all their rights and obligations under the transaction documents. This document cannot be reproduced except in full, without prior written approval of the Company. Any unauthorized alteration, forgery or falsification of the content or appearance of this document is unlawful and offenders may be prosecuted to the fullest extent of the law.

## Test Report

No. : CE/2011/72710 Date : 2011/07/19 Page : 6 of 7

SHENZHEN MICROGATE TECHNOLOGY., LTD.  
YUXING ROAD, GOLF STREET, GUANLAN TOWN, BAO'AN DISTRICT, SHENZHEN



### Analytical flow chart of halogen content

- 1) Name of the person who made measurement: Rita Chen
- 2) Name of the person in charge of measurement: Troy Chang

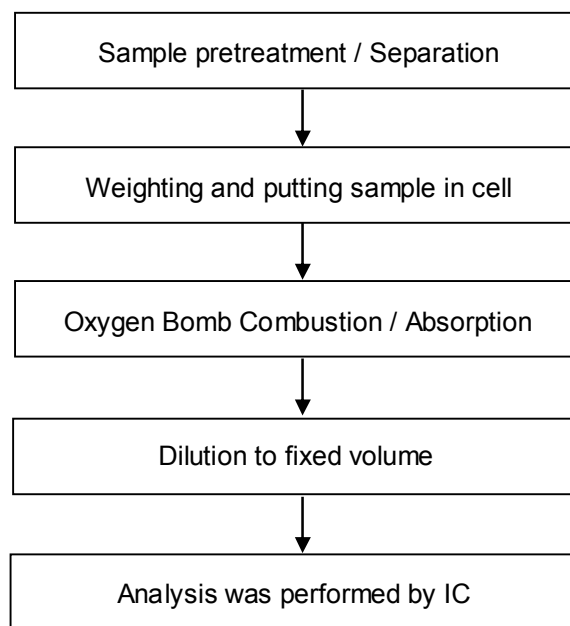

Unless otherwise stated the results shown in this test report refer only to the sample(s) tested. This test report cannot be reproduced, except in full, without prior written permission of the Company. 除非另有說明，此報告結果僅對測試的樣品負責。本報告未經本公司書面許可，不可部份複製。  
This document is issued by the Company subject to its General Conditions of Service printed overleaf, available on request or accessible at [www.sgs.com/terms\\_and\\_conditions.htm](http://www.sgs.com/terms_and_conditions.htm) and, for electronic format documents, subject to Terms and Conditions for Electronic Documents at [www.sgs.com/terms\\_e-document.htm](http://www.sgs.com/terms_e-document.htm). Attention is drawn to the limitation of liability, indemnification and jurisdiction issues defined therein. Any holder of this document is advised that information contained hereon reflects the Company's findings at the time of its intervention only and within the limits of Client's instructions, if any. The Company's sole responsibility is to its Client and this document does not exonerate parties to a transaction from exercising all their rights and obligations under the transaction documents. This document cannot be reproduced except in full, without prior written approval of the Company. Any unauthorized alteration, forgery or falsification of the content or appearance of this document is unlawful and offenders may be prosecuted to the fullest extent of the law.

## Test Report

No. : CE/2011/72710 Date : 2011/07/19 Page : 7 of 7

SHENZHEN MICROGATE TECHNOLOGY., LTD.

YUXING ROAD, GOLF STREET, GUANLAN TOWN, BAO'AN DISTRICT, SHENZHEN

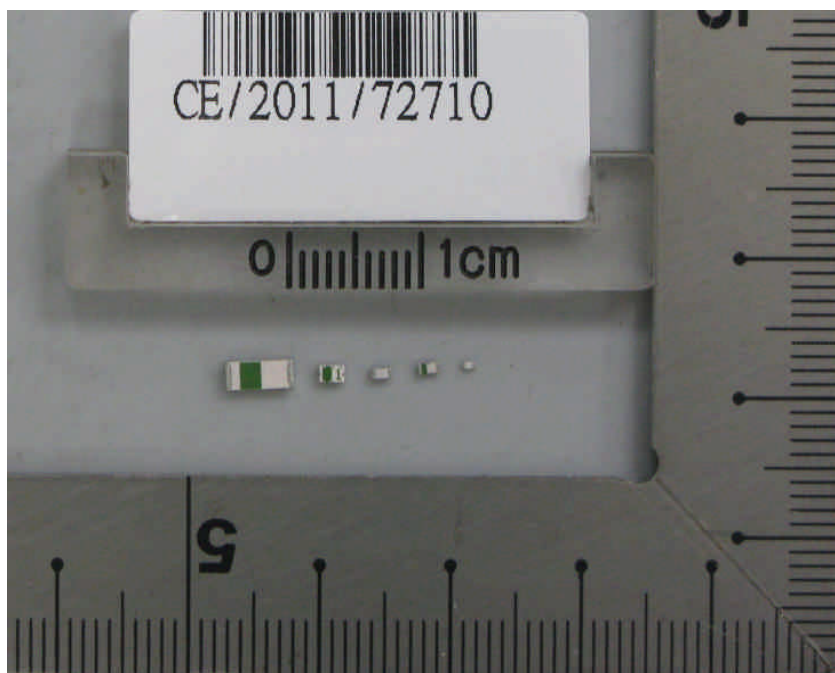
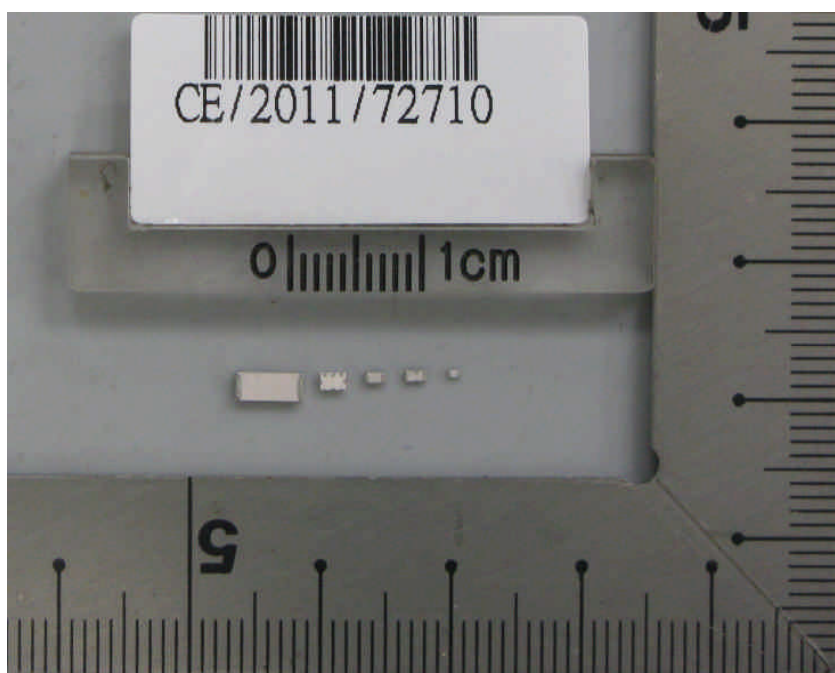

**\*\* End of Report \*\***

Unless otherwise stated the results shown in this test report refer only to the sample(s) tested. This test report cannot be reproduced, except in full, without prior written permission of the Company. 除非另有說明，此報告結果僅對測試的樣品負責。本報告未經本公司書面許可，不可部份複製。

This document is issued by the Company subject to its General Conditions of Service printed overleaf, available on request or accessible at [www.sgs.com/terms\\_and\\_conditions.htm](http://www.sgs.com/terms_and_conditions.htm) and, for electronic format documents, subject to Terms and Conditions for Electronic Documents at [www.sgs.com/terms\\_e-document.htm](http://www.sgs.com/terms_e-document.htm). Attention is drawn to the limitation of liability, indemnification and jurisdiction issues defined therein. Any holder of this document is advised that information contained hereon reflects the Company's findings at the time of its intervention only and within the limits of Client's instructions, if any. The Company's sole responsibility is to its Client and this document does not exonerate parties to a transaction from exercising all their rights and obligations under the transaction documents. This document cannot be reproduced except in full, without prior written approval of the Company. Any unauthorized alteration, forgery or falsification of the content or appearance of this document is unlawful and offenders may be prosecuted to the fullest extent of the law.

## X-ON Electronics

Largest Supplier of Electrical and Electronic Components

*Click to view similar products for [Antennas](#) category:*

*Click to view products by [microgate](#) manufacturer:*

Other Similar products are found below :

[CCT FM1](#) [ABFT](#) [AD-NM-SMAF 001-0021](#) [CTC110](#) [MAF94149](#) [EXE902SF](#) [MMCX-SMA-100](#) [PDQ24496-91NF](#) [GAN30084EU](#) [930-033-R](#) [A08-HABUF-P5I](#) [AAF95035](#) [DG-ANT-20DP-BG-B](#) [APAMPGJ-141](#) [1513563-1](#) [OF86315-FNF](#) [OP24516DS-91NM](#) [A09-HASM-7](#) [EXE902MD](#) [EXE902SM](#) [SPDA17806/2170LAR](#) [APAMPG-117](#) [GPS1575SP26-004](#) [GPS15MGSMA](#) [CMD69273P-30NF](#) [CMQ69273-30NF](#) [RD2458-5-OTDR-NM](#) [RD2458-5-RSMA](#) [TRAB24/49003](#) [W4120ER5000](#) [W6102B0100](#) [YE572113-30RSMM](#) [108-00014-50](#) [SPDA17RP918](#) [OP24516SX-91NM](#) [OP24516SX-91RSMM](#) [CMQ69273P-30NF](#) [CMS69273-30NF](#) [CMS69273P-30NF](#) [TRAB24003N](#) [TRAB24003NP](#) [TRAB8213NP](#) [TRAB8903](#) [A09-Y8NF](#) [A09-Y11NF](#) [A09-HSM-7](#) [A09-F8NF-M](#) [A09-F5NF-M](#)