

Micron Parallel NOR Flash Embedded Memory

Top/Bottom Boot Block 5V Supply

M29F200FT/B, M29F400FT/B, M29F800FT/B, M29F160FT/B

Features

- Supply voltage
 - $V_{CC} = 5V$
- Access time: 55ns
- Program/erase controller
 - Embedded byte/word program algorithms
- Erase suspend and resume modes
- Low power consumption
 - Standby and automatic standby
- 100,000 PROGRAM/ERASE cycles per block
- Electronic signature
 - Manufacturer code: 0x01h
- Top device codes
 - M29F200FT: 0x2251
 - M29F400FT: 0x2223
 - M29F800FT: 0x22D6
 - M29F160FT: 0x22D2
- Bottom device codes
 - M29F200FB: 0x2257
 - M29F400FB: 0x22AB
 - M29F800FB: 0x2258
 - M29F160FB: 0x22D8
- RoHS-compliant packages
 - TSOP48
 - SO44 (16Mb not available for this package)
- Automotive device grade 3
 - Temperature: -40 to $+125^{\circ}C$
- Automotive device grade 6
 - Temperature: -40 to $+85^{\circ}C$
- Automotive grade certified (AEC-Q100)

Part Numbering Information

Devices are shipped from the factory with memory content bits erased to 1. For available options, such as packages, or for further information, contact your Micron sales representative. Part numbers can be verified at www.micron.com. Feature and specification comparison by device type is available at www.micron.com/products. Contact the factory for devices not found.

Table 1: Part Number Information

Part Number Category	Category Details
Device Type	M29F = 5V
Density	200 = 2Mb
	400 = 4Mb
	800 = 8Mb
	160 = 16Mb (not available in SO 44 package)
Technology	F = 110nm
Configuration	T = Top boot
	B = Bottom boot
Speed	55 = 55ns device speed in conjunction with temperature range = 3, which denotes Auto Grade – 40 to 125 °C parts
	5A = 55ns access time (Auto Grade) only in conjunction with the Grade 6 option
Package	M = SO 44
	N = TSOP 48 12mm x 20mm AL 42
Temperature Range	6 = –40°C to +85°C
	3 = –40°C to +125°C
Shipping Options	blank = standard packing (Tray)
	E = RoHS-compliant package, standard packing (tray)
	T = Tape and reel packing (24mm)
	F = RoHS-compliant package, tape and reel packing (24mm)
Fab Location	2 = Fab 13 (Singapore)

Contents

Important Notes and Warnings	6
General Description	6
Signal Assignments	16
TSOP Pin Assignments	16
Small-Outline Pin Assignments	20
Signal Descriptions	23
Bus Operations	25
Read	25
Write	25
Output Disable	25
Standby	25
Automatic Standby	25
Command Interface	26
READ/RESET Command	26
AUTO SELECT Command	26
PROGRAM Command	27
UNLOCK BYPASS Command	27
UNLOCK BYPASS PROGRAM Command	28
UNLOCK BYPASS RESET Command	28
CHIP ERASE Command	28
BLOCK ERASE Command	28
ERASE SUSPEND Command	29
ERASE RESUME Command	29
READ CFI QUERY Command	29
16-Bit Mode Commands	30
8-Bit Mode Commands	31
Block Protection Operations	32
Programmer Technique	33
In-System Technique	35
Status Register	37
Data Polling Bit	37
Toggle Bit	38
Error Bit	39
Erase Timer Bit	39
Alternative Toggle Bit	40
Common Flash Interface (CFI)	41
Maximum Ratings and Operating Conditions	45
DC Electrical Specifications	47
AC Read Characteristics	48
AC Write Characteristics	50
Reset Specifications	52
PROGRAM/ERASE Characteristics	53
Package Dimensions	54
Revision History	56
Rev. C – 5/18	56
Rev. B – 2/14	56
Rev. A – 2/13	56

List of Figures

Figure 1: Logic Diagram	7
Figure 2: Block Addresses, M29F160 (x8)	7
Figure 3: Block Addresses, M29F160 (x16)	9
Figure 4: Block Addresses, M29F800 (x8)	10
Figure 5: Block Addresses, M29F800 (x16)	11
Figure 6: Block Addresses, M29F400 (x8)	12
Figure 7: Block Addresses, M29F400 (x16)	13
Figure 8: Block Addresses, M29F200 (x8)	14
Figure 9: Block Addresses, M29F200 (x16)	15
Figure 10: M29F160F	16
Figure 11: M29F800F	17
Figure 12: M29F400F	18
Figure 13: M29F200F	19
Figure 14: M29F800	20
Figure 15: M29F400	21
Figure 16: M29F200	22
Figure 17: Block Protect Flowchart – Programmer Equipment	33
Figure 18: Chip Unprotect Flowchart – Programmer Equipment	34
Figure 19: Block Protect Flowchart – In-System Equipment	35
Figure 20: Chip Protection Flowchart – In-System Equipment	36
Figure 21: Data Polling Flowchart	38
Figure 22: Data Toggle Flowchart	39
Figure 23: AC Measurement I/O Waveform	45
Figure 24: AC Measurement Load Circuit	46
Figure 25: Read Mode AC Waveforms	48
Figure 26: Write AC Waveforms, Write Enable Controlled	50
Figure 27: Write AC Waveforms, Chip Enable Controlled	51
Figure 28: Reset/Block Temporary Unprotect AC Waveforms	52
Figure 29: 48-Lead TSOP – 12mm x 20mm	54
Figure 30: 44-Lead Small-Outline – 500 Mil	55

List of Tables

Table 1: Part Number Information	2
Table 2: Signal Descriptions	23
Table 3: Bus Operations	25
Table 4: Read Electronic Signature	27
Table 5: 16-Bit Mode Commands (BYTE# = HIGH)	30
Table 6: 8-Bit Mode Commands (BYTE# = LOW)	31
Table 7: Block and Chip Protection Signal Settings	32
Table 8: Status Register Bits	37
Table 9: Query Structure Overview	41
Table 10: CFI Query Identification String	41
Table 11: CFI Query System Interface Information	42
Table 12: Device Geometry Definition	42
Table 13: Primary Algorithm-Specific Extended Query Table	43
Table 14: Security Code Area	44
Table 15: Absolute Maximum Ratings	45
Table 16: Operating and AC Measurement Conditions	45
Table 17: Device Capacitance	46
Table 18: DC Characteristics	47
Table 19: Read AC Characteristics	48
Table 20: Write AC Characteristics, Write Enable Controlled	50
Table 21: Write AC Characteristics, Chip Enable Controlled	51
Table 22: Reset/Block Temporary Unprotect AC Characteristics	52
Table 23: Program/Erase Characteristics	53

Important Notes and Warnings

Micron Technology, Inc. ("Micron") reserves the right to make changes to information published in this document, including without limitation specifications and product descriptions. This document supersedes and replaces all information supplied prior to the publication hereof. You may not rely on any information set forth in this document if you obtain the product described herein from any unauthorized distributor or other source not authorized by Micron.

Automotive Applications. Products are not designed or intended for use in automotive applications unless specifically designated by Micron as automotive-grade by their respective data sheets. Distributor and customer/distributor shall assume the sole risk and liability for and shall indemnify and hold Micron harmless against all claims, costs, damages, and expenses and reasonable attorneys' fees arising out of, directly or indirectly, any claim of product liability, personal injury, death, or property damage resulting directly or indirectly from any use of non-automotive-grade products in automotive applications. Customer/distributor shall ensure that the terms and conditions of sale between customer/distributor and any customer of distributor/customer (1) state that Micron products are not designed or intended for use in automotive applications unless specifically designated by Micron as automotive-grade by their respective data sheets and (2) require such customer of distributor/customer to indemnify and hold Micron harmless against all claims, costs, damages, and expenses and reasonable attorneys' fees arising out of, directly or indirectly, any claim of product liability, personal injury, death, or property damage resulting from any use of non-automotive-grade products in automotive applications.

Critical Applications. Products are not authorized for use in applications in which failure of the Micron component could result, directly or indirectly in death, personal injury, or severe property or environmental damage ("Critical Applications"). Customer must protect against death, personal injury, and severe property and environmental damage by incorporating safety design measures into customer's applications to ensure that failure of the Micron component will not result in such harms. Should customer or distributor purchase, use, or sell any Micron component for any critical application, customer and distributor shall indemnify and hold harmless Micron and its subsidiaries, subcontractors, and affiliates and the directors, officers, and employees of each against all claims, costs, damages, and expenses and reasonable attorneys' fees arising out of, directly or indirectly, any claim of product liability, personal injury, or death arising in any way out of such critical application, whether or not Micron or its subsidiaries, subcontractors, or affiliates were negligent in the design, manufacture, or warning of the Micron product.

Customer Responsibility. Customers are responsible for the design, manufacture, and operation of their systems, applications, and products using Micron products. ALL SEMICONDUCTOR PRODUCTS HAVE INHERENT FAILURE RATES AND LIMITED USEFUL LIVES. IT IS THE CUSTOMER'S SOLE RESPONSIBILITY TO DETERMINE WHETHER THE MICRON PRODUCT IS SUITABLE AND FIT FOR THE CUSTOMER'S SYSTEM, APPLICATION, OR PRODUCT. Customers must ensure that adequate design, manufacturing, and operating safeguards are included in customer's applications and products to eliminate the risk that personal injury, death, or severe property or environmental damages will result from failure of any semiconductor component.

Limited Warranty. In no event shall Micron be liable for any indirect, incidental, punitive, special or consequential damages (including without limitation lost profits, lost savings, business interruption, costs related to the removal or replacement of any products or rework charges) whether or not such damages are based on tort, warranty, breach of contract or other legal theory, unless explicitly stated in a written agreement executed by Micron's duly authorized representative.

General Description

This description applies specifically to the M29F 16Mb (2 Meg x 8 or 1 Meg x 16) nonvolatile memory device, but also applies to lower densities. The device enables READ, ERASE, and PROGRAM operations using a single, low-voltage (4.5–5.5V) supply. On

power-up, the device defaults to read mode and can be read in the same way as a ROM or EPROM.

The device is divided into blocks that can be erased independently, preserving valid data while old data is erased. Each block can be protected independently to prevent accidental PROGRAM or ERASE operations from modifying the memory. PROGRAM and ERASE commands are written to the command interface. An on-chip program/erase controller simplifies the process of programming or erasing the device by managing the operations required to update the memory contents.

The end of a PROGRAM or ERASE operation can be detected and any error conditions identified. The command set required to control the memory is consistent with JEDEC standards.

The blocks are asymmetrically arranged. The first or last 64KB have been divided into four additional blocks. The 16KB boot block can be used for small initialization code to start the microprocessor. The two 8KB parameter blocks can be used for parameter storage. The remaining 32KB is a small main block where the application may be stored.

CE#, OE#, and WE# control the bus operation of the memory. They enable simple connection to most microprocessors, often without additional logic. Devices are offered in 48-pin TSOP (12mm x 20mm) and 44-pin small-outline packages. The device is supplied with all the bits erased (set to 1).

Figure 1: Logic Diagram

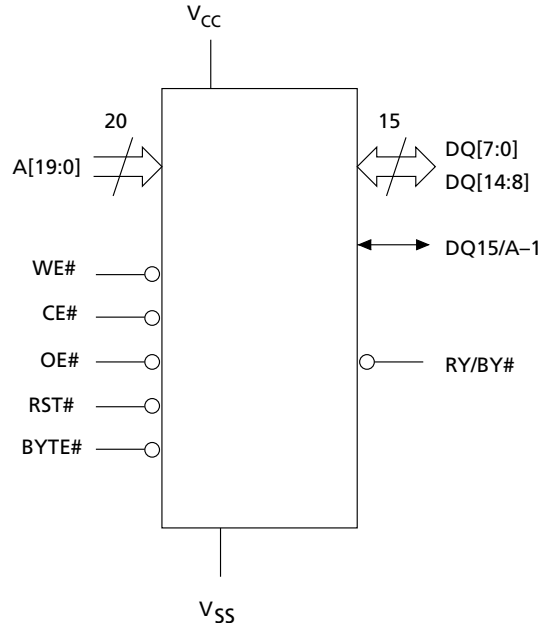

Figure 2: Block Addresses, M29F160 (x8)

Top boot block addresses (x8)

Bottom boot block addresses (x8)

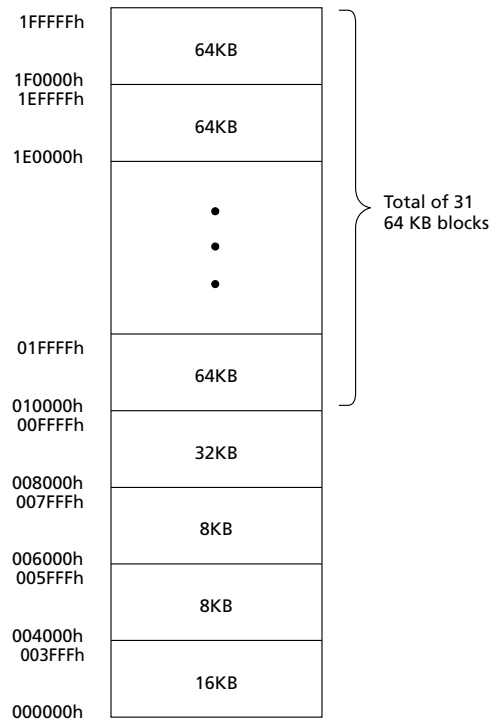
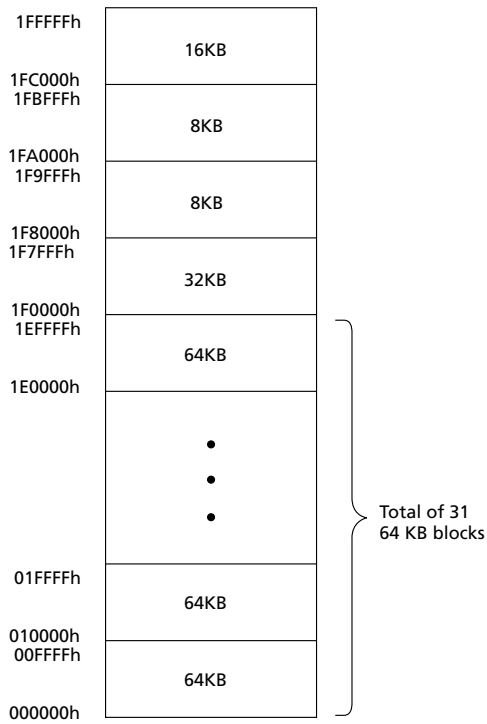

Figure 3: Block Addresses, M29F160 (x16)

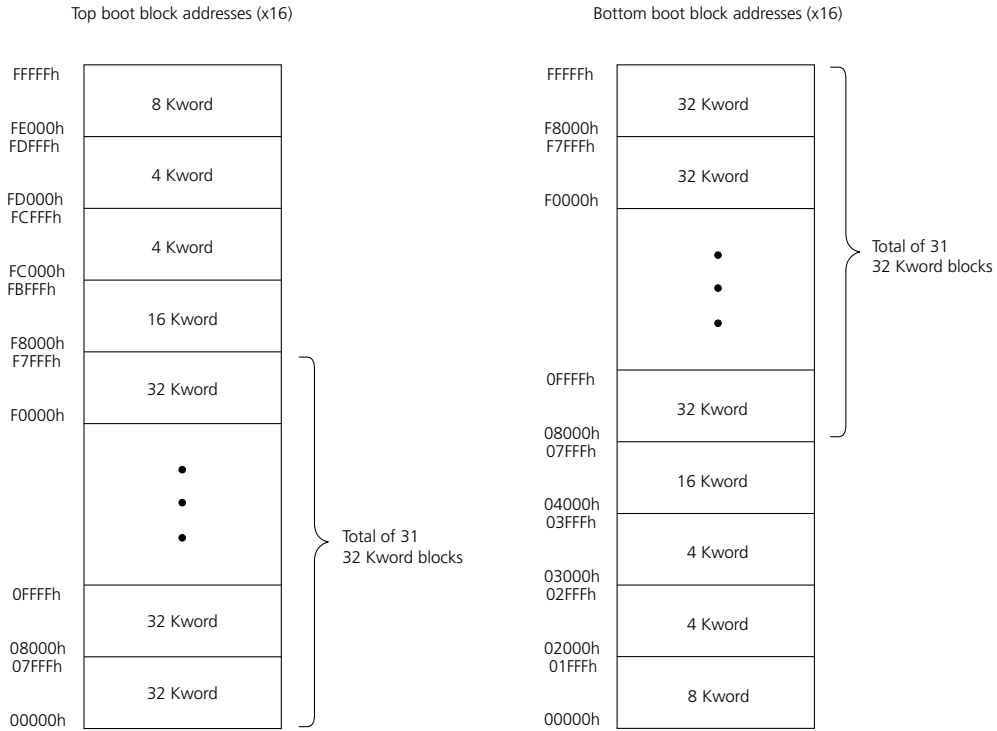

Figure 4: Block Addresses, M29F800 (x8)

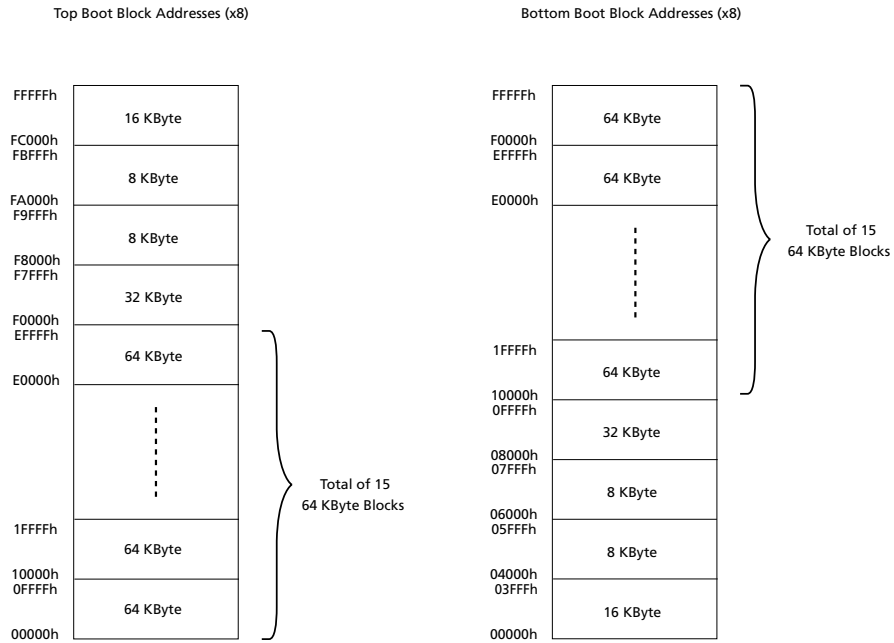

Figure 5: Block Addresses, M29F800 (x16)

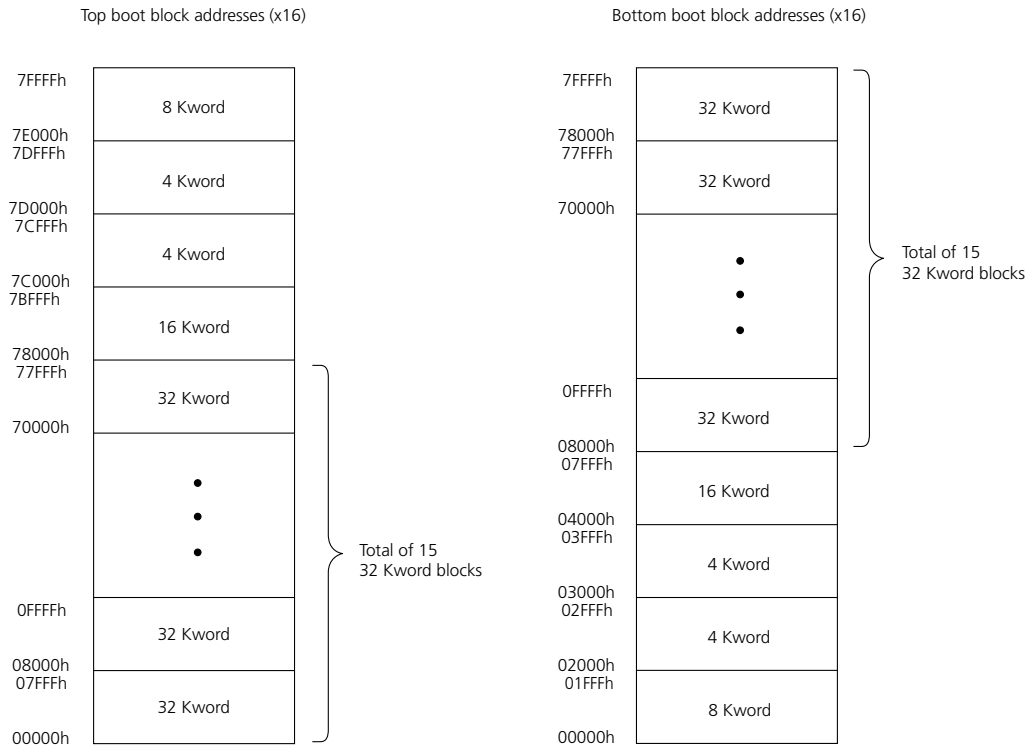

Figure 6: Block Addresses, M29F400 (x8)

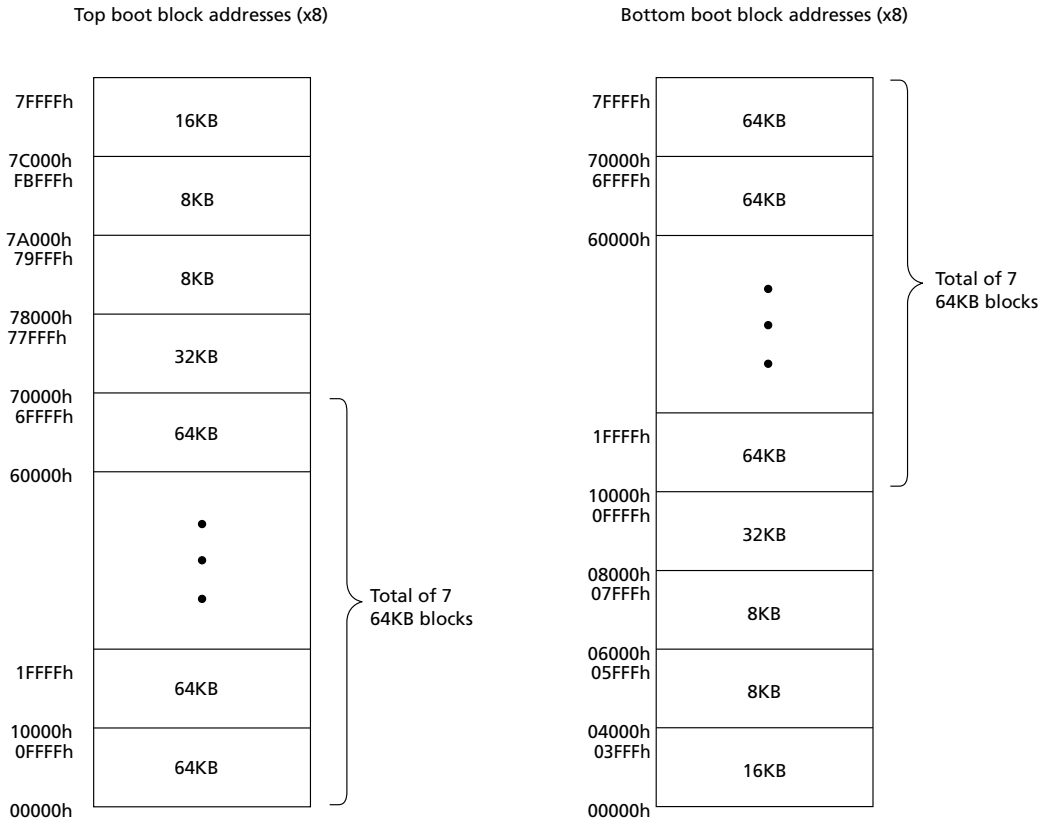

Figure 7: Block Addresses, M29F400 (x16)

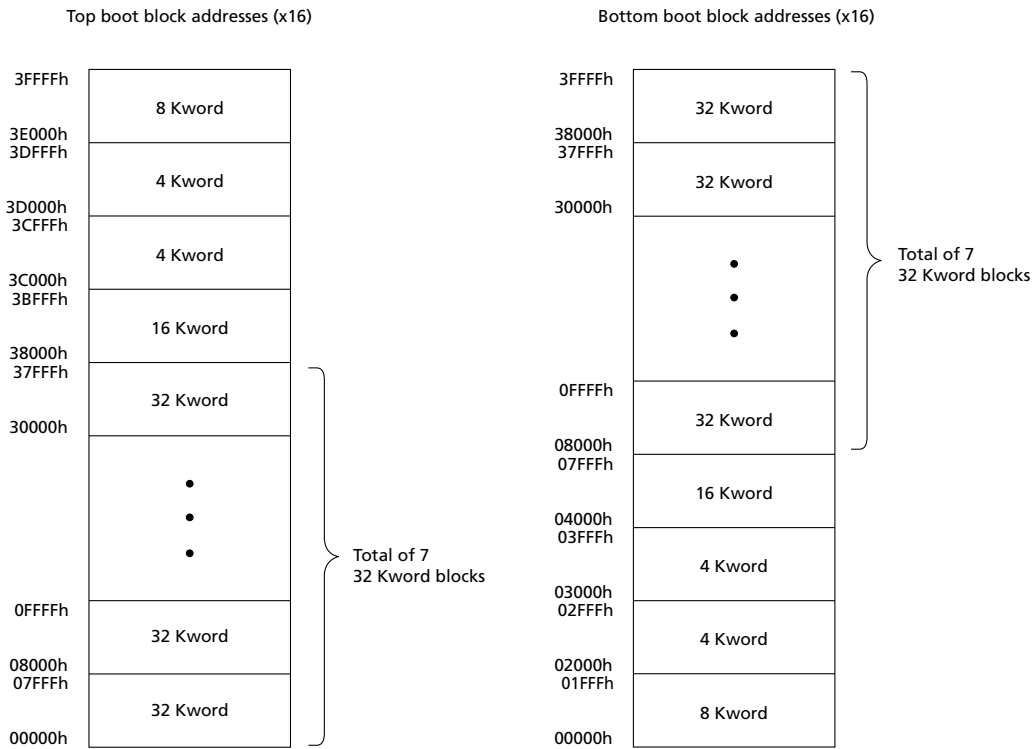

Figure 8: Block Addresses, M29F200 (x8)

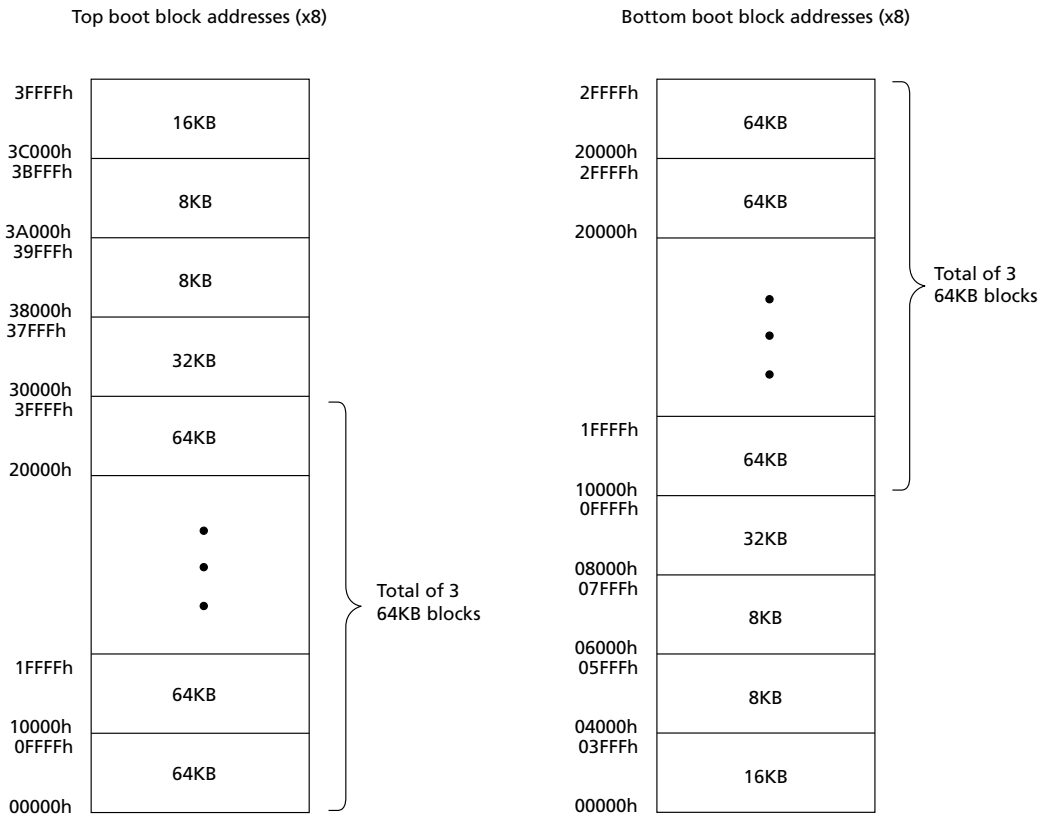
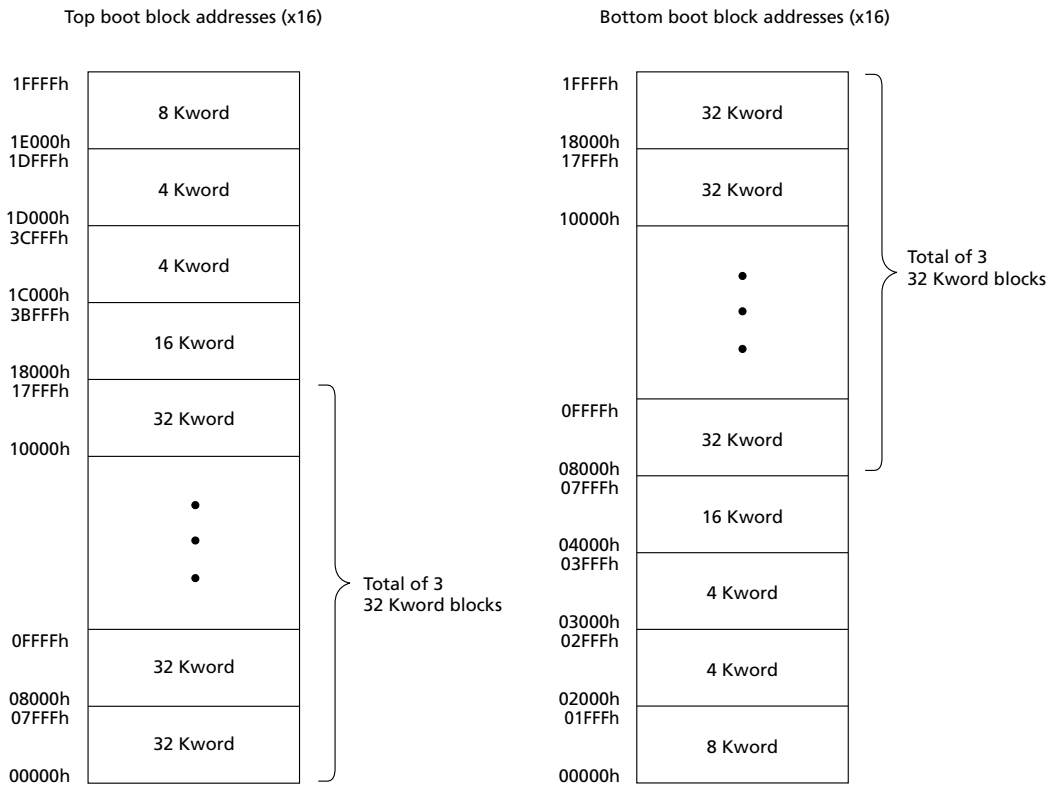

Figure 9: Block Addresses, M29F200 (x16)



Signal Assignments

TSOP Pin Assignments

Figure 10: M29F160F

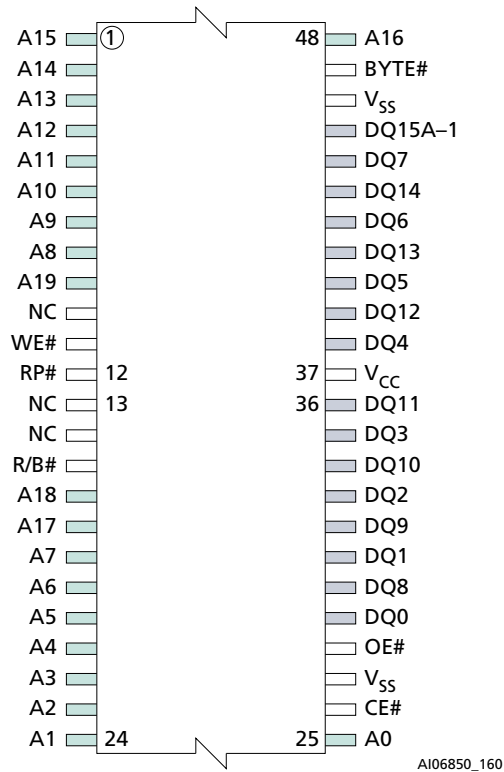

Figure 11: M29F800F

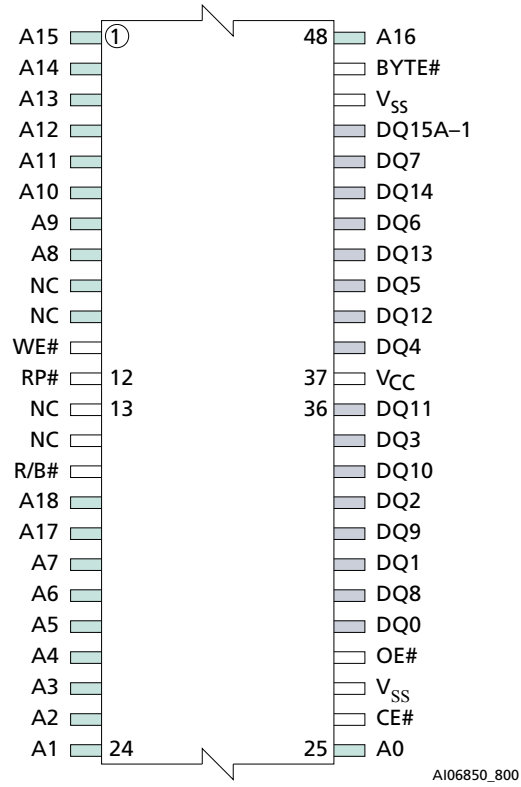

Figure 12: M29F400F

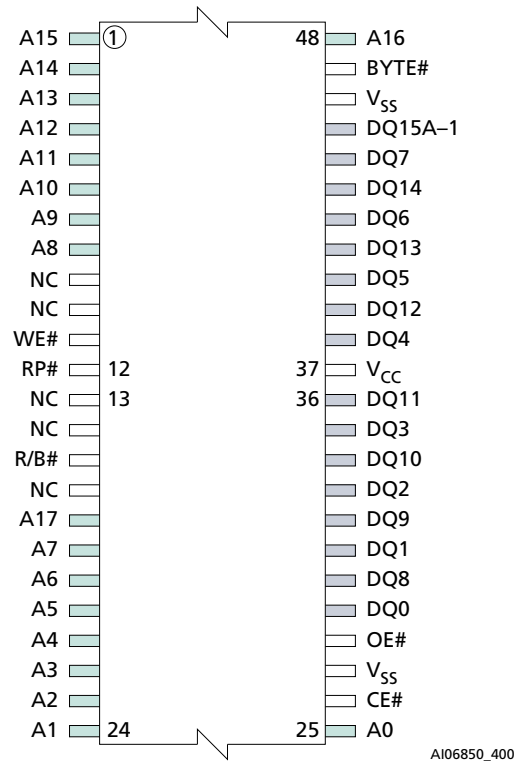
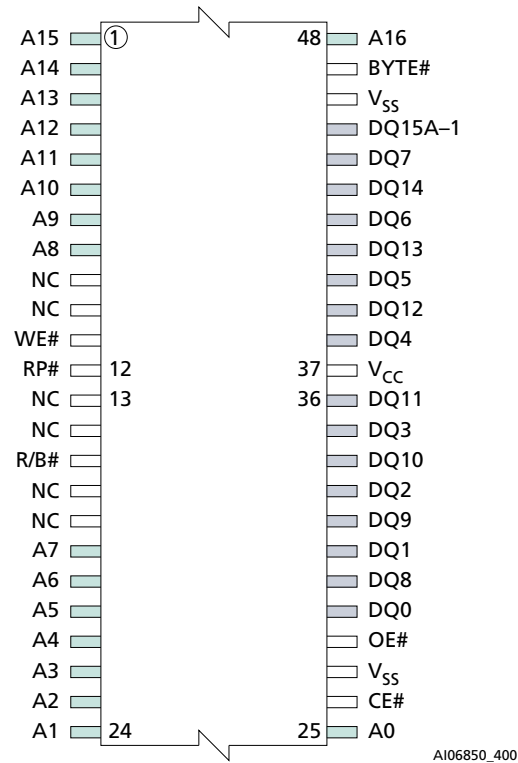
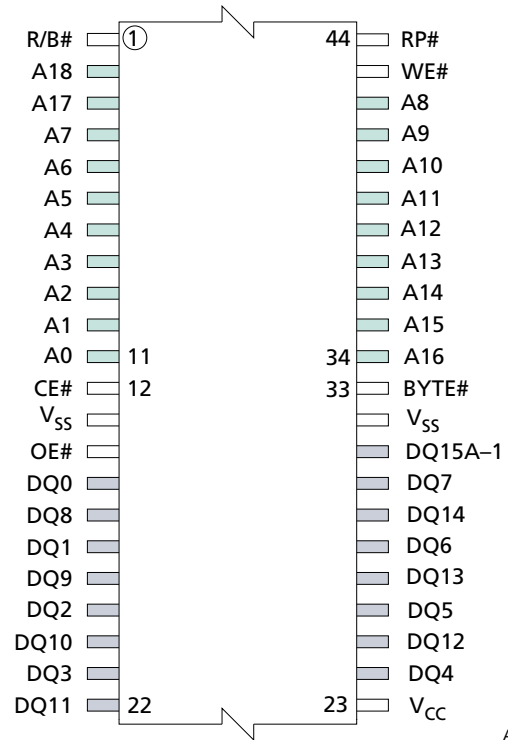

Figure 13: M29F200F



Small-Outline Pin Assignments

Figure 14: M29F800



AI02906_800

Figure 15: M29F400

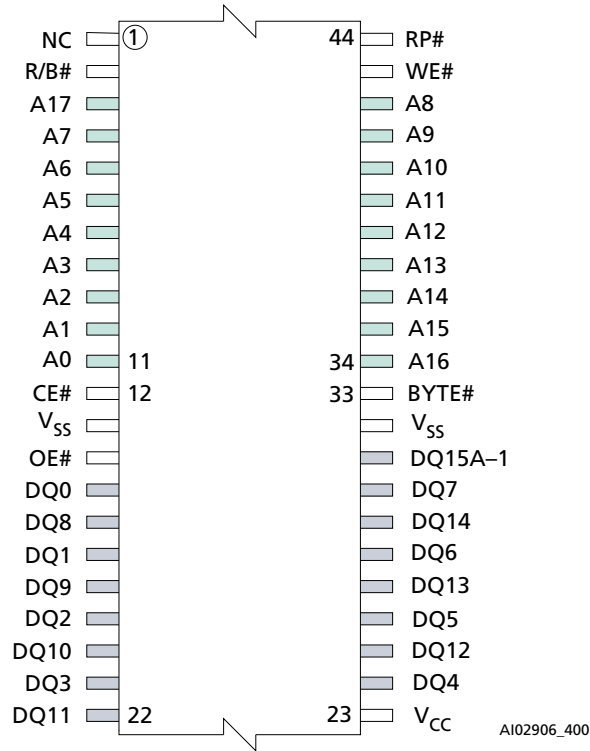
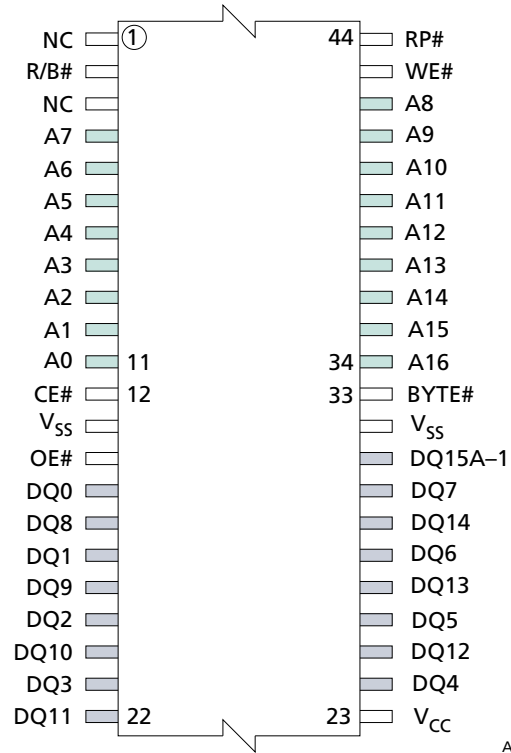

Figure 16: M29F200



AI02906_200

Signal Descriptions

The signal description table below is a comprehensive list of signals for this device family. All signals listed may not be supported on this device. See Signal Assignments for information specific to this device.

Table 2: Signal Descriptions

Name	Type	Description
A[MAX:0]	Input	Address: Selects the cells in the array to access during READ operations. During WRITE operations, they control the commands sent to the command interface of the program/erase controller.
CE#	Input	Chip enable: Activates the device, enabling READ and WRITE operations to be performed. When CE# is HIGH, all other pins are ignored.
OE#	Input	Output enable: Controls the bus READ operation.
WE#	Input	Write enable: Controls the bus WRITE operation of the command interface.
BYTE#	Input	Byte/word organization select: Switches between x8 and x16 bus modes. When BYTE# is LOW, the device is in x8 mode; when HIGH, the device is in x16 mode.
RST#	Input	Reset: Applies a hardware reset to the device, which is achieved by holding RST# LOW for at least t^{PLPX} . After RST# goes HIGH, the device is ready for READ and WRITE operations (after t^{PHEL} or t^{RHEL} , whichever occurs last). Holding RST# at V_{ID} will temporarily unprotect the protected blocks. PROGRAM and ERASE operations on all blocks will then be possible. The transition from V_{IH} to V_{ID} must be slower than t^{PHPHH} .
DQ[7:0]	I/O	Data I/O: Outputs the data stored at the selected address during a READ operation. During WRITE operations, they represent the commands sent to the command interface of the program/erase controller.
DQ[14:8]	I/O	Data I/O: Outputs the data stored at the selected address during a READ operation when BYTE# is HIGH. When BYTE# is LOW, these pins are not used and are High-Z. During WRITE operations, these bits are not used. When reading the status register, these bits should be ignored.
DQ15/A-1	I/O	Data I/O or address input: When the device operates in x16 bus mode, this pin behaves as data I/O, together with DQ[14:8]. When the device operates in x8 bus mode, this pin behaves as the least significant bit of the address. Except where stated explicitly otherwise, DQ15 = data I/O (x16 mode); A-1 = address input (x8 mode).
RY/BY#	Output	Ready busy: Open-drain output that can be used to identify when the device is performing a PROGRAM or ERASE operation. During PROGRAM or ERASE operations, RY/BY# is LOW, and is High-Z during read mode, auto select mode, and erase suspend mode. After a hardware reset, READ and WRITE operations cannot begin until RY/BY# goes High-Z (see RESET AC Specifications for more details). The use of an open-drain output enables the RY/BY# pins from several devices to be connected to a single pull-up resistor to V_{CCQ} . A low value will then indicate that one (or more) of the devices is (are) busy.

Table 2: Signal Descriptions (Continued)

Name	Type	Description
V _{CC}	Supply	<p>Supply voltage: Provides the power supply for READ, PROGRAM, and ERASE operations. The command interface is disabled when V_{CC} < V_{LKO}. This prevents WRITE operations from accidentally damaging the data during power-up, power-down, and power surges. If the program/erase controller is programming or erasing during this time, then the operation aborts and the contents being altered will be invalid.</p> <p>A 0.1μF capacitor should be connected between V_{CC} and V_{SS} to decouple the current surges from the power supply. The PCB track widths must be sufficient to carry the currents required during PROGRAM and ERASE operations (see DC Characteristics).</p>
V _{SS}	Supply	<p>Ground: Reference for all voltage measurements. All V_{SS} pins must be connected to the system ground.</p>
NC	–	<p>Not connected: Not connected internally.</p>

Bus Operations

Table 3: Bus Operations

Notes 1 through 2 apply to entire table

Operation	CE#	OE#	WE#	8-Bit Mode			16-Bit Mode	
				A[MAX:0], DQ15/A-1	DQ[14:8]	DQ[7:0]	A[MAX:0]	DQ15/A-1, DQ[14:0]
READ	L	L	H	Cell address	High-Z	Data output	Cell address	Data output
WRITE	L	H	L	Command address	High-Z	Data input	Command address	Data input
OUTPUT DISABLE	X	H	H	X	High-Z	High-Z	X	High-Z
STANDBY	H	X	X	X	High-Z	High-Z	X	High-Z

- Notes: 1. H = Logic level HIGH (V_{IH}); L = Logic level LOW (V_{IL}); X = HIGH or LOW.
 2. Typically glitches of less than 5ns on Chip Enable or Write Enable are ignored by the memory and do not affect bus operations.

Read

Bus READ operations read from the memory cells or specific registers in the command interface. A valid bus READ operation involves setting the desired address on the address inputs, taking CE# and OE# LOW, and holding WE# HIGH. The data I/Os will output the value. (See AC Characteristics for details about when the output becomes valid.)

Write

Bus WRITE operations write to the command interface. A valid bus WRITE operation begins by setting the desired address on the address inputs. The address inputs are latched by the command interface on the falling edge of CE# or WE#, whichever occurs last. The data I/Os are latched by the command interface on the rising edge of CE# or WE#, whichever occurs first. OE# must remain HIGH during the entire bus WRITE operation. (See AC Characteristics for timing requirement details.)

Output Disable

Data I/Os are High-Z when OE# is HIGH.

Standby

When CE# is HIGH, the device enters standby, and data I/Os are High-Z. To reduce the supply current to the standby supply current (I_{CC2}), CE# must be held within $V_{CC} \pm 0.2V$. (See DC Characteristics.) During PROGRAM or ERASE operations the device will continue to use the program/erase supply current (I_{CC3}) until the operation completes.

Automatic Standby

If CMOS levels ($V_{CC} \pm 0.2V$) are used to drive the bus, and the bus is inactive for 150ns or more, the device enters automatic standby, and the internal supply current is reduced to that of the standby supply current, I_{CC2} . The data I/Os will output data if a READ operation is in progress.

Command Interface

All WRITE operations are interpreted by the command interface. Commands consist of one or more sequential WRITE operations. Failure to observe a valid sequence will result in the memory returning to read mode. The long command sequences are imposed to maximize data security.

The address used for the commands changes depending on whether the memory is in 16-bit or 8-bit mode.

READ/RESET Command

The READ/RESET command returns the device to read mode, where it behaves like a ROM or EPROM, unless otherwise stated. It also resets the errors in the status register. Either one or three WRITE operations can be used to issue the READ/RESET command.

The READ/RESET command can be issued, between WRITE cycles, before the start of a PROGRAM or ERASE operation, to return the device to read mode. Once the PROGRAM or ERASE operation has started, the READ/RESET command is no longer accepted. The READ/RESET command will not abort an ERASE operation when issued while in erase suspend.

AUTO SELECT Command

The AUTO SELECT command is used to read the electronic signature, including the manufacturer code, the device code and the block protection status. Three consecutive WRITE operations are required to issue the AUTO SELECT command. Once the command is issued, the memory remains in auto select mode until a READ/RESET command is issued. READ CFI QUERY and READ/RESET commands are accepted in auto select mode, while all other commands are ignored.

Note: These operations are intended for use by programming equipment and are not typically used in applications. They require V_{ID} to be applied to some of the pins.

From the auto select mode the manufacturer code can be read using a READ operation with $A0 = V_{IL}$ and $A1 = V_{IL}$. The other address bits may be set to either V_{IL} or V_{IH} . The manufacturer code for Micron is 0001h.

The device code can be read using a READ operation with $A0 = V_{IH}$ and $A1 = V_{IL}$. The other address bits may be set to either V_{IL} or V_{IH} .

The block protection status of each block can be read using a READ operation with $A0 = V_{IL}$, $A1 = V_{IH}$, and $A12-A19$ specifying the address of the block. The other address bits may be set to either V_{IL} or V_{IH} . If the addressed block is protected then 01h is output on Data Inputs/Outputs DQ0-DQ7, otherwise 00h is output. See Block Protection Operations for information on the block protection status; the Programmer Technique Block Protection table includes block protection bus READ information.

Table 4: Read Electronic Signature

Notes 1 applies to entire table.

Operation	CE#	OE#	WE#	8-Bit Mode			16-Bit Mode	
				A[MAX:0], DQ15/A-1	DQ[14:8]	DQ[7:0]	A[MAX:0]	DQ15/A-1, DQ[14:0]
READ MANUFACTURER CODE	L	L	H	A0 = V _{IL} , A1 = V _{IL} , A9 = V _{ID} , Others = V _{IL} /V _{ID}	High-Z	0x01	A0 = V _{IL} , A1 = V _{IL} , A9 = V _{ID} , Others = V _{IL} /V _{ID}	0x0001
READ DEVICE CODE	L	L	H	A0 = V _{IH} , A1 = V _{IL} , A9 = V _{ID} , Others = V _{IL} /V _{IH}	High-Z	0x51 (M29F200FT) 0x57 (M29F200FB) 0x23 (M29F400FT) 0xAB(M29F400FB) 0xD6 (M29F800FT) 0x58 (M29F800FB) 0xD2 (M29F160FT) 0xD8 (M29F160FB)	A0 = V _{IH} , A1 = V _{IL} , A9 = V _{ID} , Others = V _{IL} /V _{IH}	0x2251 (M29F200FT) 0x2257 (M29F200FB) 0x2223 (M29F400FT) 0x22AB (M29F400FB) 0x22D6 (M29F800FT) 0x2258 (M29F800FB) 0x22D2 (M29F160FT) 0x22D8(M29F160FB)

 Note: 1. H = Logic level HIGH (V_{IH}); L = Logic level LOW (V_{IL}); X = HIGH or LOW.

PROGRAM Command

The PROGRAM command can be used to program a value to one address at a time. The command requires four bus WRITE operations. The final WRITE operation latches the address and data, and starts the program/erase controller.

If the address falls in a protected block, then the PROGRAM command is ignored, the data remains unchanged. The status register is never read and no error condition is given.

During the PROGRAM operation, the memory will ignore all commands. It is not possible to issue any command to abort or pause the operation. Typical program times are given in READ CFI QUERY Command. READ operations during the PROGRAM operation will output the status register on the data I/Os. (See Registers.)

After the PROGRAM operation has completed, the memory returns to read mode, unless an error has occurred. When an error occurs, the memory continues to output the status register. A READ/RESET command must be issued to reset the error condition and return to read mode.

Note that the PROGRAM command cannot change a bit set at 0 back to 1. One of the ERASE commands must be used to set all the bits in a block, or in the whole device, from 0 to 1.

UNLOCK BYPASS Command

The UNLOCK BYPASS command is used in conjunction with the UNLOCK BYPASS PROGRAM command to program the memory. When the access time to the device is long (as with some EPROM programmers), considerable time saving can be made by using these commands. Three WRITE operations are required to issue the UNLOCK BYPASS command.

Once the UNLOCK BYPASS command has been issued, the memory will only accept the UNLOCK BYPASS PROGRAM command and the UNLOCK BYPASS RESET command. The memory can be read as though in read mode.

UNLOCK BYPASS PROGRAM Command

The UNLOCK BYPASS PROGRAM command can be used to program one address in memory at a time. The command requires two WRITE operations, the final write operation latches the address and data, and starts the program/erase controller.

The PROGRAM operation using the UNLOCK BYPASS PROGRAM command behaves identically to the PROGRAM operation using the PROGRAM command. A protected block cannot be programmed; the operation cannot be aborted and the status register is read. Errors must be reset using the READ/RESET command, which leaves the device in unlock bypass mode. (See the PROGRAM command for details.)

UNLOCK BYPASS RESET Command

The UNLOCK BYPASS RESET command can be used to return to read/reset mode from unlock bypass mode. Two WRITE operations are required to issue the UNLOCK BYPASS RESET command. The READ/RESET command does not exit from unlock bypass mode.

CHIP ERASE Command

The CHIP ERASE command can be used to erase the entire chip. Six WRITE operations are required to issue the CHIP ERASE command and start the program/erase controller.

If any blocks are protected then these are ignored and all the other blocks are erased. If all of the blocks are protected, the CHIP ERASE operation appears to start but will terminate within about 100 μ s, leaving the data unchanged. No error condition is given when protected blocks are ignored.

During an ERASE operation, the memory will ignore all commands. It is not possible to issue any command to abort the operation. Typical chip erase times are given in READ CFI QUERY Command. All READ operations during the CHIP ERASE operation will output the status register on the data I/Os. (See Registers for more details.)

After the CHIP ERASE operation has completed, the memory will return to read mode, unless an error has occurred. When an error occurs, the memory will continue to output the status register. A READ/RESET command must be issued to reset the error condition and return to read mode.

The CHIP ERASE command sets all of the bits in unprotected blocks to 1. All previous data is lost.

BLOCK ERASE Command

The BLOCK ERASE command can be used to erase a list of one or more blocks. Six WRITE operations are required to select the first block in the list. Each additional block in the list can be selected by repeating the sixth WRITE operation, using the address of the additional block. The BLOCK ERASE operation starts the program/erase controller about 50 μ s after the last WRITE operation. Once the program/erase controller starts, it is not possible to select any more blocks. Each additional block must therefore be selected within 50 μ s of the last block. The 50 μ s timer restarts when an additional block is selected. The status register can be read after the sixth WRITE operation. See Status Regis-

ter for details on how to identify whether the program/erase controller has started the BLOCK ERASE operation.

If any selected blocks are protected, then these are ignored and all the other selected blocks are erased. If all of the selected blocks are protected, the BLOCK ERASE operation appears to start but will terminate within about 100 μ s, leaving the data unchanged. No error condition is given when protected blocks are ignored.

During the BLOCK ERASE operation, the device will ignore all commands except the ERASE SUSPEND command. All READ operations during the BLOCK ERASE operation will output the status register on the data I/Os.

After the BLOCK ERASE operation has completed, the device will return to read mode, unless an error has occurred. When an error occurs, the device will continue to output the status register. A READ/RESET command must be issued to reset the error condition and return to read mode.

The BLOCK ERASE command sets all of the bits in the unprotected selected blocks to 1. All previous data in the selected blocks is lost.

ERASE SUSPEND Command

The ERASE SUSPEND command may be used to temporarily suspend a BLOCK ERASE operation and return the device to read mode. The command requires one WRITE operation.

The program/erase controller will suspend within the erase suspend latency time of the ERASE SUSPEND command being issued. Once the program/erase controller has stopped, the device will be set to read mode and the erase will be suspended. If the ERASE SUSPEND command is issued during the period when the device is waiting for an additional block (before the program/erase controller starts), then the erase is suspended immediately and will start immediately when the ERASE SUSPEND command is issued. It is not possible to select any further blocks to erase after the erase resume.

During erase suspend, it is possible to read and program cells in blocks that are not being erased; both READ and PROGRAM operations behave as normal on these blocks. If any attempt is made to program in a protected block or in the suspended block then the PROGRAM command is ignored and the data remains unchanged. The status register is not read and no error condition is given. Reading from blocks that are being erased will output the status register.

It is also possible to issue the AUTO SELECT, READ CFI QUERY, and UNLOCK BYPASS commands during an erase suspend. The READ/RESET command must be issued to return the device to read array mode before the RESUME command will be accepted.

ERASE RESUME Command

The ERASE RESUME command must be used to restart the program/erase controller from erase suspend. An erase can be suspended and resumed more than once.

READ CFI QUERY Command

The READ CFI QUERY command reads data from the CFI. This command is valid when the device is in read array mode, or when the device is in auto select mode. One WRITE cycle is required to issue the READ CFI QUERY command. Once the command is issued, subsequent READ operations then read from the CFI. The READ/RESET command

must be issued to return the device to the previous mode (read array or auto select mode). A second READ/RESET command would be needed if the device is to be placed in read array from auto select mode.

16-Bit Mode Commands

Table 5: 16-Bit Mode Commands (BYTE# = HIGH)

Command	Length	WRITE Operations											
		1st		2nd		3rd		4th		5th		6th	
		Addr	Data	Addr	Data	Addr	Data	Addr	Data	Addr	Data	Addr	Data
READ/RESET	1	X	F0										
	3	555	AA	2AA	55	X	F0						
AUTO SELECT	3	555	AA	2AA	55	555	90						
PROGRAM	4	555	AA	2AA	55	555	A0	PA	PD				
UNLOCK BYPASS	3	555	AA	2AA	55	555	20						
UNLOCK BYPASS PROGRAM	2	X	A0	PA	PD								
UNLOCK BYPASS RESET	2	X	90	X	00								
CHIP ERASE	6	555	AA	2AA	55	555	80	555	AA	2AA	55	555	10
BLOCK ERASE	6+	555	AA	2AA	55	555	80	555	AA	2AA	55	BA	30
ERASE SUSPEND	1	X	B0										
ERASE RESUME	1	X	30										
READ CFI QUERY	1	55	98										

- Notes:
1. X = "Don't Care;" PA = Program address; PD = Program data; BA = Any address in the block. All values in the table are in hexadecimal.
 2. Command interface: Only uses A-1, A[10;0], and DQ[7;0] to verify the commands; A[19;11], DQ[14;8], and DQ15 are "Don't Care." DQ15/A-1 is A-1 when BYTE is LOW or DQ15 when BYTE is HIGH.
 3. **Read/Reset:** After a READ/RESET command, read the memory as normal until another command is issued.
 4. **Auto Select:** After an AUTO SELECT command, read manufacturer ID, device ID, or block protection status.
 5. **Program, Unlock Bypass Program, Chip Erase, Block Erase:** After issuing these commands, read the status register until the program/erase controller completes and the device returns to read mode. Add additional blocks during a BLOCK ERASE command with additional bus WRITE operations until the timeout bit is set.
 6. **Unlock Bypass:** After the UNLOCK BYPASS command, issue an UNLOCK BYPASS PROGRAM or UNLOCK BYPASS RESET command.
 7. **Unlock Bypass Reset:** After the UNLOCK BYPASS RESET command, read the memory as normal until another command is issued.
 8. **Erase Suspend:** After the ERASE SUSPEND command, read non-erasing blocks as normal. Issue AUTO SELECT and PROGRAM commands on non-erasing blocks as normal.
 9. **Erase Resume:** After the ERASE RESUME command, the suspended ERASE operation resumes. Read the status register until the program/erase controller completes and the device returns to read mode.

10. **CFI Query:** Command is valid when device is ready to read array data or when device is in auto select mode.

8-Bit Mode Commands

Table 6: 8-Bit Mode Commands (BYTE# = LOW)

Command	Length	WRITE Operations											
		1st		2nd		3rd		4th		5th		6th	
		Addr	Data	Addr	Data	Addr	Data	Addr	Data	Addr	Data	Addr	Data
READ/RESET	1	X	F0										
	3	AAA	AA	555	55	X	F0						
AUTO SELECT	3	AAA	AA	555	55	AAA	90						
PROGRAM	4	AAA	AA	555	55	AAA	A0	PA	PD				
UNLOCK BYPASS	3	AAA	AA	555	55	AAA	20						
UNLOCK BYPASS PROGRAM	2	X	A0	PA	PD								
UNLOCK BYPASS RESET	2	X	90	X	00								
CHIP ERASE	6	AAA	AA	555	55	AAA	80	AAA	AA	555	55	AAA	10
BLOCK ERASE	6+	AAA	AA	555	55	AAA	80	AAA	AA	555	55	BA	30
ERASE SUSPEND	1	X	B0										
ERASE RESUME	1	X	30										
READ CFI QUERY	1	AA	98										

- Notes:
1. X = "Don't Care;" PA = Program address; PD = Program data; BA = Any address in the block. All values in the table are in hexadecimal.
 2. Command interface: Only uses A-1, A[10;0], and DQ[7;0] to verify the commands; A[19;11], DQ[14;8], and DQ15 are "Don't Care." DQ15/A-1 is A-1 when BYTE is LOW or DQ15 when BYTE is HIGH.
 3. **Read/Reset:** After a READ/RESET command, read the memory as normal until another command is issued.
 4. **Auto Select:** After an AUTO SELECT command, read manufacturer ID, device ID, or block protection status.
 5. **Program, Unlock Bypass Program, Chip Erase, Block Erase:** After issuing these commands, read the status register until the program/erase controller completes and the device returns to read mode. Add additional blocks during a BLOCK ERASE command with additional bus WRITE operations until the timeout bit is set.
 6. **Unlock Bypass:** After the UNLOCK BYPASS command, issue an UNLOCK BYPASS PROGRAM or UNLOCK BYPASS RESET command.
 7. **Unlock Bypass Reset:** After the UNLOCK BYPASS RESET command, read the memory as normal until another command is issued.
 8. **Erase Suspend:** After the ERASE SUSPEND command, read non-erasing blocks as normal. Issue AUTO SELECT and PROGRAM commands on non-erasing blocks as normal.
 9. **Erase Resume:** After the ERASE RESUME command, the suspended ERASE operation resumes. Read the status register until the program/erase controller completes and the device returns to read mode.
 10. **CFI Query:** Command is valid when device is ready to read array data or when device is in auto select mode.

Block Protection Operations

Block protection can be used to prevent any operation from modifying the data stored in the Flash memory. Each Block can be protected individually. Once protected, Program and Erase operations on the block fail to change the data. Block protection status of the device is read using the AUTO SELECT command.

Two techniques for controlling block protection are explained here: Programmer technique and In-System technique.

Note: A third technique for controlling block protection, Temporary Unprotection, is described in the Signal Descriptions table, RP pin (Reset/Block Temporary Unprotection).

Unlike the Command Interface of the Program/Erase Controller, the techniques for protecting and unprotecting blocks could change between different Flash memory suppliers.

Table 7: Block and Chip Protection Signal Settings

Signals	Block Protect	Chip Unprotect	Verify Block Protection	Verify Block Unprotect
CE#	L	V _{ID}	L	L
OE#	V _{ID}	V _{ID}	L	L
WE#	L pulse	L pulse	H	H
Address Input, 8-Bit and 16-Bit				
A[MAX:16]	Block base address	X	Block base address	Block base address
A15		H		
A14		X		
A13		X		
A12		H		
A11	X	X	X	X
A10	X	X	X	X
A9	V _{ID}	V _{ID}	V _{ID}	V _{ID}
A8	X	X	X	X
A7	X	X	X	X
A6	X	X	L	H
A5	X	X	X	X
A4	X	X	X	X
A3	X	X	X	X
A2	X	X	X	X
A1	X	X	H	H
A0	X	X	L	L
Data I/O, 8-Bit and 16-Bit				

Table 7: Block and Chip Protection Signal Settings (Continued)

Signals	Block Protect	Chip Unprotect	Verify Block Protection	Verify Block Unprotect
DQ[15]/A-1, and DQ[14:0]	X	X	Pass = XX01h	Retry = XX01h
	X	X	Retry = XX00h	Pass = XX00h

Note: 1. H = Logic level HIGH (V_{IH}); L = Logic level LOW (V_{IL}); X = HIGH or LOW.

Programmer Technique

The Programmer technique uses high (V_{ID}) voltage levels on some of the bus pins. These cannot be achieved using a standard microprocessor bus, therefore the technique is recommended only for use in Programming Equipment.

To protect a block, follow the Programmer Equipment Block Protect flowchart. During the Block Protect algorithm, the A19-A12 Address Inputs indicate the address of the block to be protected. The block will be correctly protected only if A19-A12 remain valid and stable, and if Chip Enable is kept Low, V_{IL} , all along the Protect and Verify phases.

The Chip Unprotect algorithm is used to unprotect all the memory blocks at the same time. This algorithm can only be used if all of the blocks are protected first. To unprotect the chip follow the Programmer Equipment Chip Unprotect flowchart and the Programmer Technique Block Protection table, which give a summary of each operation.

The timing on these flowcharts is critical. Care should be taken to ensure that, where a pause is specified, it is followed as closely as possible. Do not abort the procedure before reaching the end. Chip Unprotect can take several seconds and a user message should be provided to show that the operation is progressing.

Figure 17: Block Protect Flowchart – Programmer Equipment

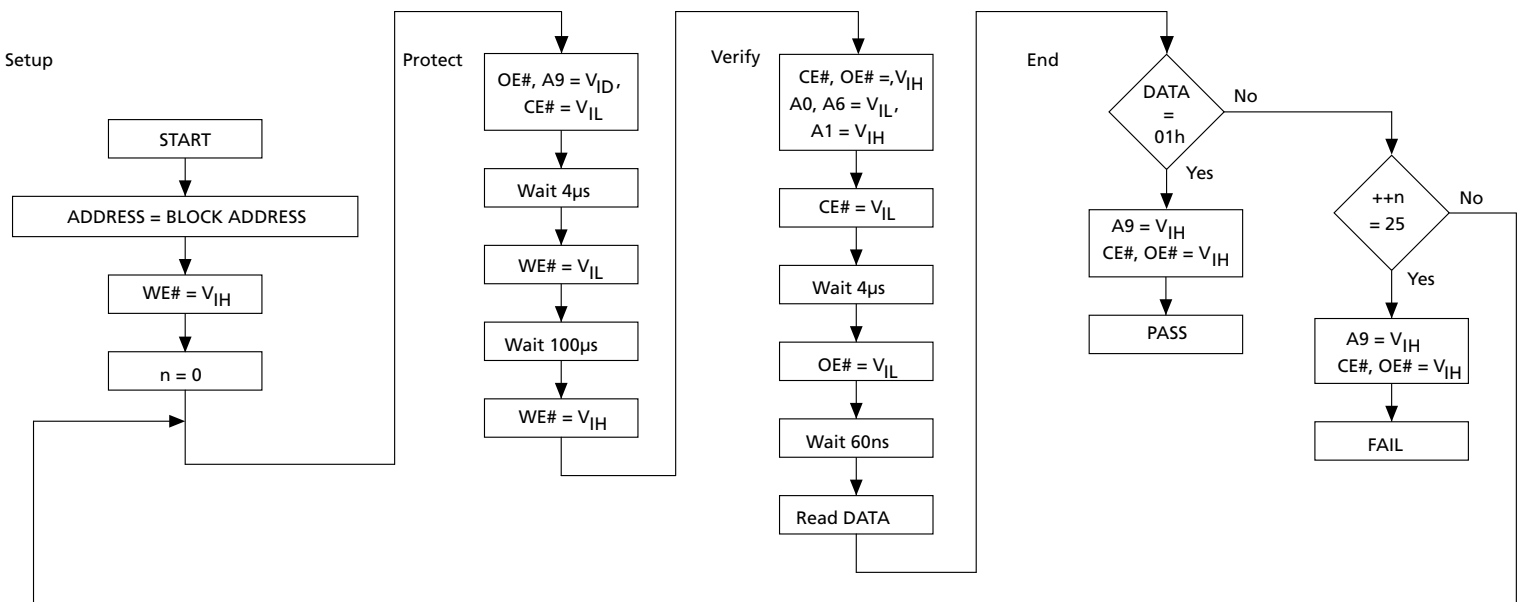
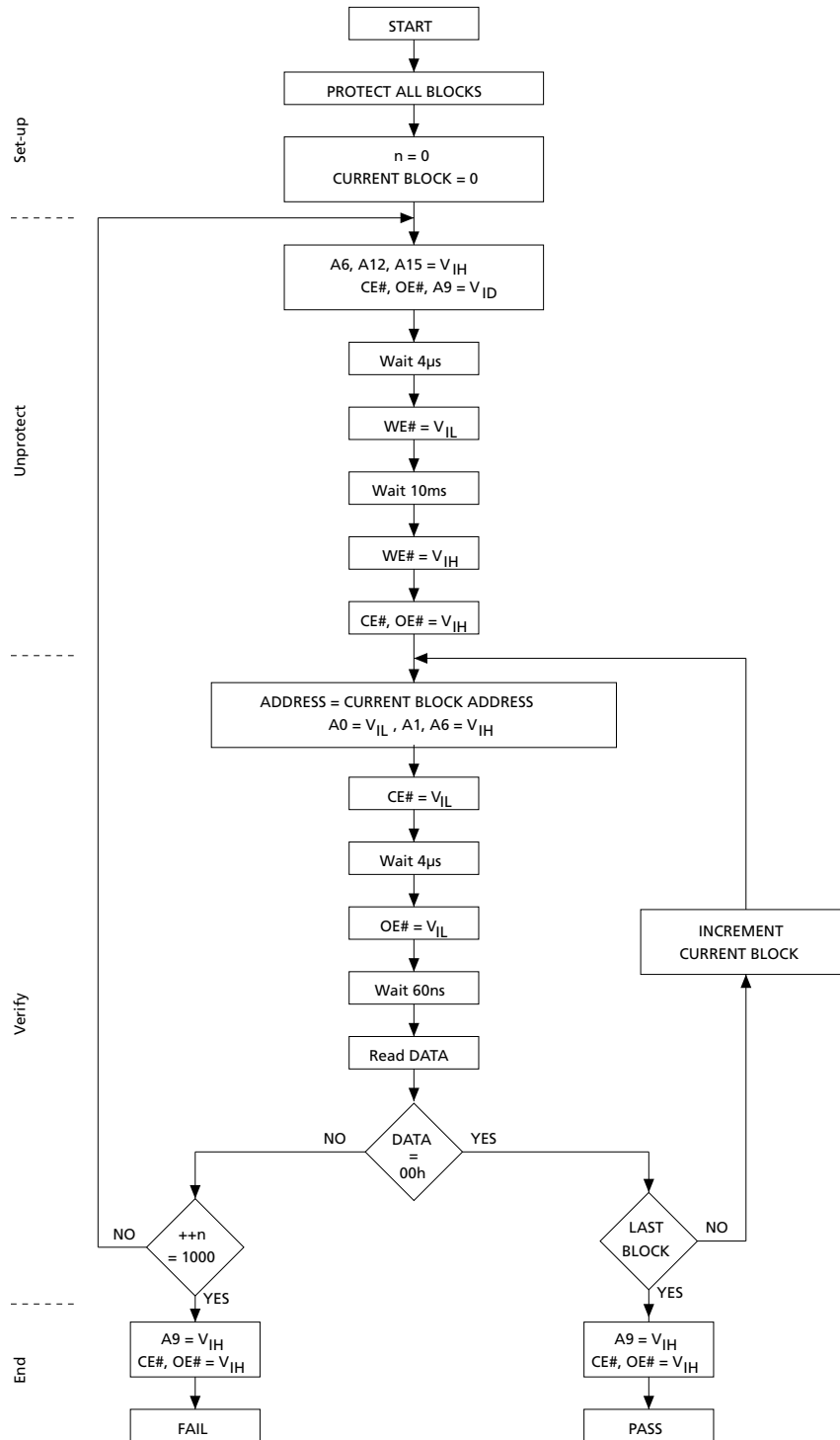

Figure 18: Chip Unprotect Flowchart – Programmer Equipment



- Notes:
1. Address Inputs A[9:12] give the address of the block that is to be protected. It is imperative that they remain stable during the operation.
 2. During the protect and verify phases of the algorithm, CE# must be kept LOW.

In-System Technique

The In-System technique requires a high voltage level on the Reset/Blocks Temporary Unprotect pin, RP. This can be achieved without violating the maximum ratings of the components on the microprocessor bus, therefore this technique is suitable for use after the Flash memory has been fitted to the system.

To protect a block follow the In-System Equipment Block Protect flowchart . To unprotect the whole chip it is necessary to protect all of the blocks first, then all the blocks can be unprotected at the same time. To unprotect the chip follow the In-System Equipment Chip Unprotect flowchart.

The timing on these flowcharts is critical. Care should be taken to ensure that, where a pause is specified, it is followed as closely as possible. Do not allow the microprocessor to service interrupts that will upset the timing and do not abort the procedure before reaching the end. Chip Unprotect can take several seconds and a user message should be provided to show that the operation is progressing.

Figure 19: Block Protect Flowchart – In-System Equipment

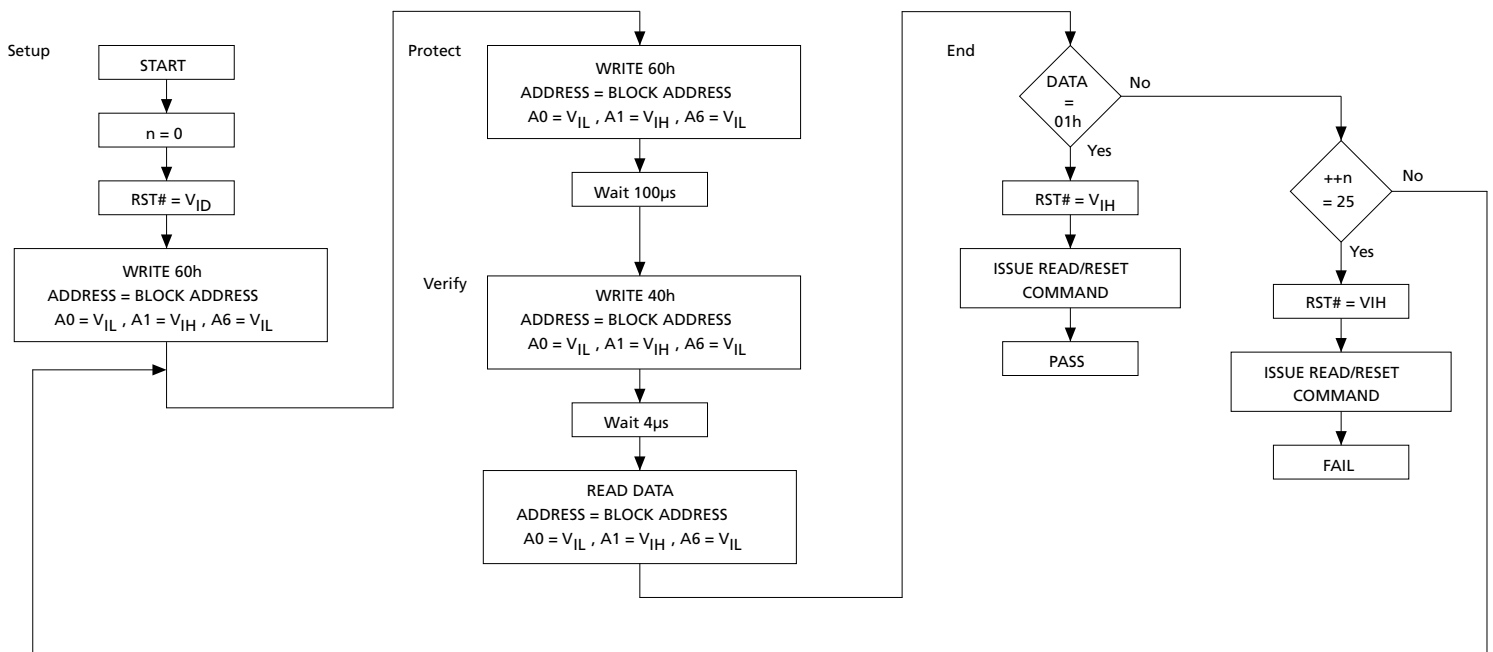
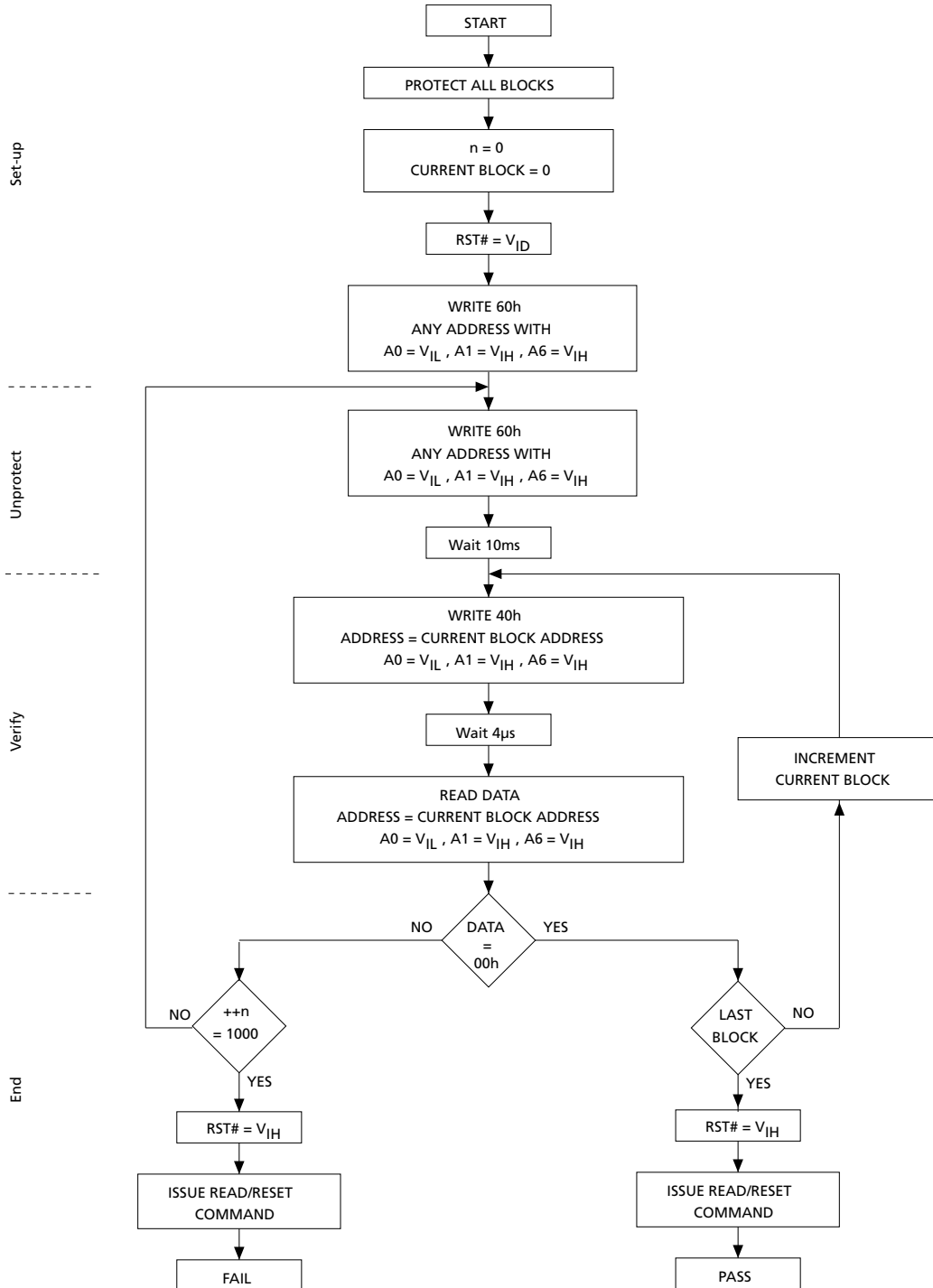

Figure 20: Chip Protection Flowchart – In-System Equipment



Status Register

Bus Read operations from any address always read the Status Register during Program and Erase operations. It is also read during Erase Suspend when an address within a block being erased is accessed.

Table 8: Status Register Bits

Operation	Address	DQ7	DQ6	DQ5	DQ3	DQ2	RB#
Program	Any Address	DQ7#	Toggle	0	–	–	0
Program During Erase Suspend	Any Address	DQ7#	Toggle	0	–	–	0
Program Error	Any Address	DQ7#	Toggle	1	–	–	0
Chip Erase	Any Address	0	Toggle	0	1	Toggle	0
Block Erase before time-out	Erasing Block	0	Toggle	0	0	Toggle	0
	Non-Erasing Block	0	Toggle	0	0	No Toggle	0
Block Erase	Erasing Block	0	Toggle	0	1	Toggle	0
	Non-Erasing Block	0	Toggle	0	1	No Toggle	0
Erase Suspend	Erasing Block	1	No Toggle	0	–	Toggle	1
	Non-Erasing Block	Data read as normal					
Erase Error	Good Block Address	0	Toggle	1	1	No Toggle	0
	Faulty Block Address	0	Toggle	1	1	Toggle	0

Note: 1. Unspecified data bits should be ignored.

Data Polling Bit

The Data Polling Bit (DQ7) can be used to identify whether the Program/Erase Controller has successfully completed its operation or if it has responded to an Erase Suspend. The Data Polling Bit is output on DQ7 when the Status Register is read.

During Program operations the Data Polling Bit outputs the complement of the bit being programmed to DQ7. After successful completion of the Program operation the memory returns to Read mode and Bus Read operations from the address just programmed output DQ7, not its complement.

During Erase operations the Data Polling Bit outputs '0', the complement of the erased state of DQ7. After successful completion of the Erase operation the memory returns to Read Mode.

In Erase Suspend mode the Data Polling Bit will output a '1' during a Bus Read operation within a block being erased. The Data Polling Bit will change from a '0' to a '1' when the Program/Erase Controller has suspended the Erase operation.

The Data Polling Flowchart, gives an example of how to use the Data Polling Bit. A Valid Address is the address being programmed or an address within the block being erased.

Figure 21: Data Polling Flowchart

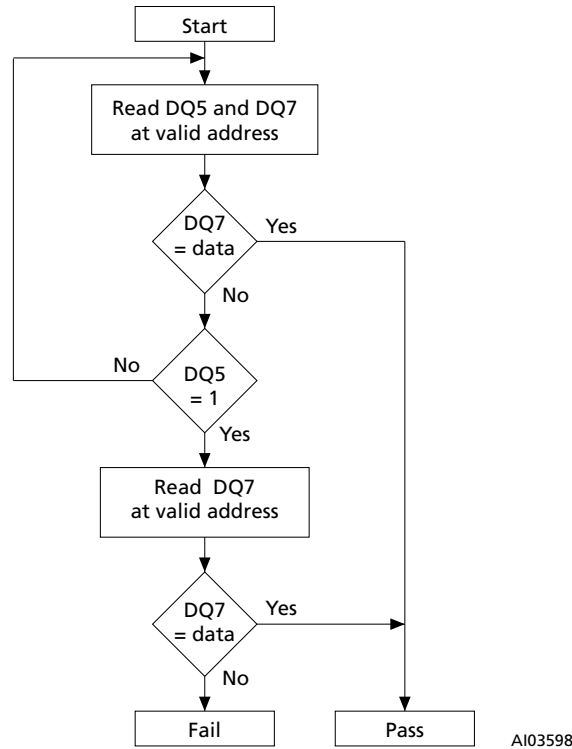

Toggle Bit

The Toggle Bit (DQ6) can be used to identify whether the Program/Erase Controller has successfully completed its operation or if it has responded to an Erase Suspend. The Toggle Bit is output on DQ6 when the Status Register is read.

During Program and Erase operations the Toggle Bit changes from '0' to '1' to '0', etc., with successive Bus Read operations at any address. After successful completion of the operation the memory returns to Read mode.

During Erase Suspend mode the Toggle Bit will output when addressing a cell within a block being erased. The Toggle Bit will stop toggling when the Program/Erase Controller has suspended the Erase operation.

If any attempt is made to erase a protected block, the operation is aborted, no error is signalled and DQ6 toggles for approximately 100µs. If any attempt is made to program a protected block or a suspended block, the operation is aborted, no error is signalled and DQ6 toggles for approximately 1µs.

The Data Toggle Flowchart, gives an example of how to use the Data Toggle Bit.

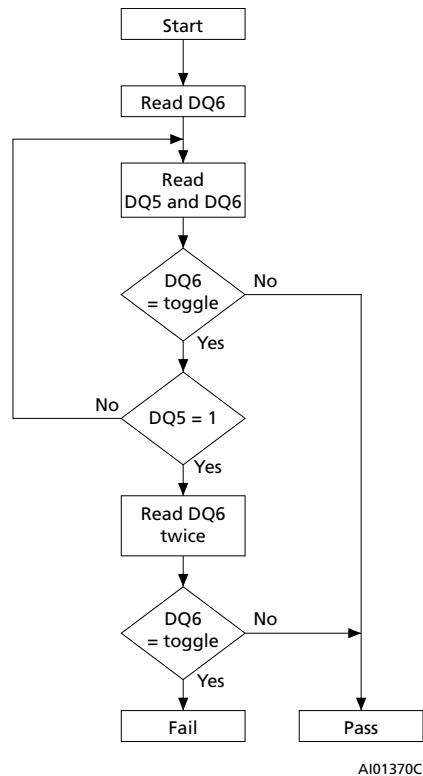
Figure 22: Data Toggle Flowchart

Error Bit

The Error Bit (DQ5) can be used to identify errors detected by the Program/Erase Controller. The Error Bit is set to '1' when a Program, Block Erase or Chip Erase operation fails to write the correct data to the memory. If the Error Bit is set a Read/Reset command must be issued before other commands are issued. The Error bit is output on DQ5 when the Status Register is read.

Note that the Program command cannot change a bit set to '0' back to '1' and attempting to do so will set DQ5 to '1'. A Bus Read operation to that address will show the bit is still '0'. One of the Erase commands must be used to set all the bits in a block or in the whole memory from '0' to '1'

Erase Timer Bit

The Erase Timer Bit (DQ3) can be used to identify the start of Program/Erase Controller operation during a Block Erase command. Once the Program/Erase Controller starts erasing the Erase Timer Bit is set to '1'. Before the Program/Erase Controller starts the Erase Timer Bit is set to '0' and additional blocks to be erased may be written to the Command Interface. The Erase Timer Bit is output on DQ3 when the Status Register is read.

Alternative Toggle Bit

The Alternative Toggle Bit (DQ2) can be used to monitor the Program/Erase controller during Erase operations. The Alternative Toggle Bit is output on DQ2 when the Status Register is read.

During Chip Erase and Block Erase operations the Toggle Bit changes from '0' to '1' to '0', etc., with successive Bus Read operations from addresses within the blocks being erased. A protected block is treated the same as a block not being erased. Once the operation completes the memory returns to Read mode.

During Erase Suspend the Alternative Toggle Bit changes from '0' to '1' to '0', etc. with successive Bus Read operations from addresses within the blocks being erased. Bus Read operations to addresses within blocks not being erased will output the memory cell data as if in Read mode.

After an Erase operation that causes the Error Bit to be set the Alternative Toggle Bit can be used to identify which block or blocks have caused the error. The Alternative Toggle Bit changes from '0' to '1' to '0', etc. with successive Bus Read Operations from addresses within blocks that have not erased correctly. The Alternative Toggle Bit does not change if the addressed block has erased correctly.

Common Flash Interface (CFI)

The Common Flash Interface is a JEDEC approved, standardized data structure that can be read from the Flash memory device. It allows a system software to query the device to determine various electrical and timing parameters, density information and functions supported by the memory. The system can interface easily with the device, enabling the software to upgrade itself when necessary.

When the CFI Query Command is issued the device enters CFI Query mode and the data structure is read from the memory. Addresses used to retrieve the data are shown in the following tables:

The CFI data structure also contains a security area where a 64-bit unique security number is written. This area can be accessed only in Read mode by the final user. It is impossible to change the security number after it has been written by Micron. Issue a Read command to return to Read mode.

Table 9: Query Structure Overview

Address		Sub-section Name	Description
x16	x8		
10h	20h	CFI Query Identification String	Command set ID and algorithm data offset
1Bh	36h	System Interface Information	Device timing & voltage information
27h	4Eh	Device Geometry Definition	Flash device layout
40h	80h	Primary Algorithm-specific Extended Query table	Additional information specific to the Primary Algorithm (optional)
61h	C2h	Security Code Area	64 bit unique device number

Note: 1. Query data are always presented on the lowest order data outputs.

Table 10: CFI Query Identification String

Address		Data	Description	Value
x16	x8			
10h	20h	0051h		"Q"
11h	22h	0052h	Query Unique ASCII String "QRY"	"R"
12h	24h	0059h		"Y"
13h	26h	0002h	Primary Algorithm Command Set and Control Interface ID code 16 bit ID code defining a specific algorithm	AMD Compatible
14h	28h	0000h		
15h	2Ah	0040h	Address for Primary Algorithm extended Query table (see the Device Geometry table.)	P = 40h
16h	2Ch	0000h		
17h	2Eh	0000h	Alternate Vendor Command Set and Control Interface ID Code second vendor - specified algorithm supported	NA
18h	30h	0000h		
19h	32h	0000h	Address for Alternate Algorithm extended Query table	NA
1Ah	34h	0000h		

Note: 1. Query data are always presented on the lowest order data outputs (DQ7-DQ0) only. DQ8-DQ15 are '0'.

Table 11: CFI Query System Interface Information

Address		Data	Description	Value
x16	x8			
1Bh	36h	0045h	V _{CC} Logic Supply Minimum Program/Erase voltage bit 7 to 4 BCD value in volts bit 3 to 0 BCD value in 100 mV	4.5V
1Ch	38h	0055h	V _{CC} Logic Supply Maximum Program/Erase voltage bit 7 to 4 BCD value in volts bit 3 to 0 BCD value in 100 mV	5.5V
1Dh	3Ah	0000h	V _{PP} [Programming] Supply Minimum Program/Erase voltage	NA
1Eh	3Ch	0000h	V _{PP} [Programming] Supply Maximum Program/Erase voltage	NA
1Fh	3Eh	0003h	Typical timeout per single Byte/Word program = 2 ⁿ μs	8μs
20h	40h	0000h	Typical timeout for minimum size write buffer program = 2 ⁿ μs	NA
21h	42h	000Ah	Typical timeout per individual block erase = 2 ⁿ ms	1 s
22h	44h	0000h	Typical timeout for full chip erase = 2 ⁿ ms	NA
23h	46h	0004h	Maximum timeout for Byte/Word program = 2 ⁿ times typical	256μs
24h	48h	0000h	Maximum timeout for write buffer program = 2 ⁿ times typical	NA
25h	4Ah	0003h	Maximum timeout per individual block erase = 2 ⁿ times typical	8 s
26h	4Ch	0000h	Maximum timeout for chip erase = 2 ⁿ times typical	NA

Table 12: Device Geometry Definition

Address		Data	Description	Value
x16	x8			
27h	4Eh	0015h	Device Size = 2 ⁿ in number of Bytes	2MB
		0014h		1MB
		0013h		512KB
		0012h		256KB
28h	50h	0002h	Flash Device Interface Code description	x8, x16 Async.
29h	52h	0000h		
2Ah	54h	0000h	Maximum number of Bytes in multi-Byte program or page = 2 ⁿ	NA
2Bh	56h	0000h		
2Ch	58h	0004h	Number of Erase Block Regions within the device. It specifies the number of regions within the device containing contiguous Erase Blocks of the same size.	4
2Dh	5Ah	0000h	Region 1 Information Number of identical size erase block = 0000h+1	1
2Eh	5Ch	0000h		
2Fh	5Eh	0040h	Region 1 Information Block size in Region 1 = 0040h * 256 Byte	16KB
30h	60h	0000h		
31h	62h	0001h	Region 2 Information Number of identical size erase block = 0001h+1	2
32h	64h	0000h		
33h	66h	0020h	Region 2 Information Block size in Region 2 = 0020h * 256 Byte	8KB
34h	68h	0000h		

Table 12: Device Geometry Definition (Continued)

Address		Data	Description	Value
x16	x8			
35h	6Ah	0000h	Region 3 Information	1
36h	6Ch	0000h	Number of identical size erase block = 0000h+1	
37h	6Eh	0080h	Region 3 Information	32KB
38h	70h	0000h	Block size in Region 3 = 0080h * 256 Byte	
39h	72h	001Eh	Region 4 Information (2 MByte)	31
3Ah	74h	0000h	Number of identical-size erase block = 001Eh+1	
39h	72h	000Eh	Region 4 Information (1 MByte)	15
3Ah	74h	0000h	Number of identical-size erase block = 000Eh+1	
39h	72h	0006h	Region 4 Information (512 KByte)	7
3Ah	74h	0000h	Number of identical-size erase block = 0006h+1	
39h	72h	0002h	Region 4 Information (256 KByte)	3
3Ah	74h	0000h	Number of identical-size erase block = 0002h+1	
3Bh	76h	0000h	Region 4 Information	64KB
3Ch	78h	0001h	Block size in Region 4 = 0100h * 256 Byte	

Table 13: Primary Algorithm-Specific Extended Query Table

Address		Data	Description	Value
x16	x8			
40h	80h	0050h	Primary Algorithm extended Query table unique ASCII string "PRI"	"P"
41h	82h	0052h		"R"
42h	84h	0049h		"I"
43h	86h	0031h	Major version number, ASCII	"1"
44h	88h	0030h	Minor version number, ASCII	"0"
45h	8Ah	0000h	Address Sensitive Unlock (bits 1 to 0) 00 = required, 01 = not required Silicon Revision Number (bits 7 to 2)	Yes
46h	8Ch	0002h	Erase Suspend 00 = not supported, 01 = Read only, 02 = Read and Write	2
47h	8Eh	0001h	Block Protection 00 = not supported, x = number of blocks in per group	1
48h	90h	0001h	Temporary Block Unprotect 00 = not supported, 01 = supported	Yes
49h	92h	0002h 0004h 0008h 0160h	Block Protect /Unprotect 02 = M29F200 04 = M29F400 08 = M29F800 10 = M29F160	2 4 8 16
4Ah	94h	0000h	Simultaneous Operations, 00 = not supported	No
4Bh	96h	0000h	Burst Mode, 00 = not supported, 01 = supported	No

Table 13: Primary Algorithm-Specific Extended Query Table (Continued)

Address		Data	Description	Value
x16	x8			
4Ch	98h	0000h	Page Mode, 00 = not supported, 01 = 4 page Word, 02 = 8 page Word	No

Table 14: Security Code Area

Address		Data	Description
x16	x8		
61h	C3h, C2h	XXXX	64 bit: unique device number
62h	C5h, C4h	XXXX	
63h	C7h, C6h	XXXX	
64h	C9h, C8h	XXXX	

Maximum Ratings and Operating Conditions

Stressing the device above the rating listed in the Absolute Maximum Ratings table may cause permanent damage to the device. Exposure to Absolute Maximum Rating conditions for extended periods may affect device reliability. These are stress ratings only and operation of the device at these or any other conditions above those indicated in the Operating sections of this specification is not implied.

Table 15: Absolute Maximum Ratings

Symbol	Parameter	Min	Max	Unit
T_{BIAS}	Temperature Under Bias	-50	125	°C
T_{STG}	Storage Temperature	-65	150	°C
V_{IO}	Input or Output Voltage	-0.6	$V_{CC} + 0.6$	V
V_{CC}	Supply Voltage	-0.6	6	V
V_{ID}	Identification Voltage	-0.6	13.5	V

- Notes:
1. Input or Output Voltage parameter: Minimum voltage may undershoot to -2V during transition and for less than 20ns during transitions.
 2. Input or Output Voltage parameter: Maximum voltage may overshoot to $V_{CC} + 2V$ during transition and for less than 20ns during transitions.

The parameters in the tables that follow, are derived from tests performed under the Measurement Conditions shown here. Designers should check that the operating conditions in their circuit match the operating conditions when relying on the quoted parameters.

Table 16: Operating and AC Measurement Conditions

Parameter	Min	Max	Unit
V_{CC} Supply Voltage	4.5	5.5	V
Ambient Operating Temperature	-40	125	°C
Load Capacitance (C_L)	30	30	pF
Input Rise and Fall Times	—	5	ns
Input Pulse Voltages	0 to V_{CC}	0 to V_{CC}	V
Input and Output Timing Reference Voltages	$V_{CC}/2$	$V_{CC}/2$	V

Figure 23: AC Measurement I/O Waveform

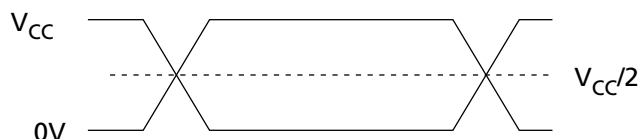

AI04498

Figure 24: AC Measurement Load Circuit

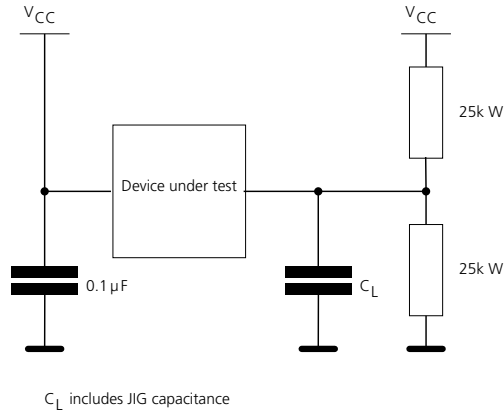

Table 17: Device Capacitance

Symbol	Parameter	Test Condition	Min	Max	Unit
C_{IN}	Input Capacitance	$V_{IN} = 0V$		6	pF
C_{OUT}	Output Capacitance	$V_{OUT} = 0V$		12	pF

Note: 1. Sampled only, not 100% tested.

DC Electrical Specifications

Table 18: DC Characteristics

Symbol	Parameter	Test Condition	Min	Typ	Max	Unit
I_{LI}	Input Leakage Current	$0V \leq V_{IN} \leq V_{CC}$	—	—	± 1	μA
I_{LO}	Output Leakage Current	$0V \leq V_{OUT} \leq V_{CC}$	—	—	± 1	μA
I_{CC1}	Supply Current (Read)	CE# = V_{IL} , OE# = V_{IH} , f = 6MHz	—	7	20	mA
I_{CC2}	Supply Current (Standby)	CE# = $V_{CC} \pm 0.2V$, RP# = $V_{CC} \pm 0.2V$	—	60	120	μA
I_{CC3}	Supply Current (Program/Erase)	Program/Erase Controller active	—	—	30	mA
V_{IL}	Input Low Voltage	—	-0.5	—	0.8	V
V_{IH}	Input High Voltage	—	$0.7V_{CC}$	—	$V_{CC} + 0.3$	V
V_{OL}	Output Low Voltage	$I_{OL} = 1.8mA$	—	—	0.45	V
V_{OH}	Output High Voltage	$I_{OH} = -100\mu A$	$V_{CC} - 0.4$	—	—	V
V_{ID}	Identification Voltage	—	11.5	—	12.5	V
I_{ID}	Identification Current	A9 = V_{ID}	—	—	100	μA
V_{LKO}	Program/Erase Lockout Supply Voltage	—	1.8	—	2.3	V

Note: 1. Supply Current (Program/Erase) parameter: Sampled only, not 100% tested.

AC Read Characteristics

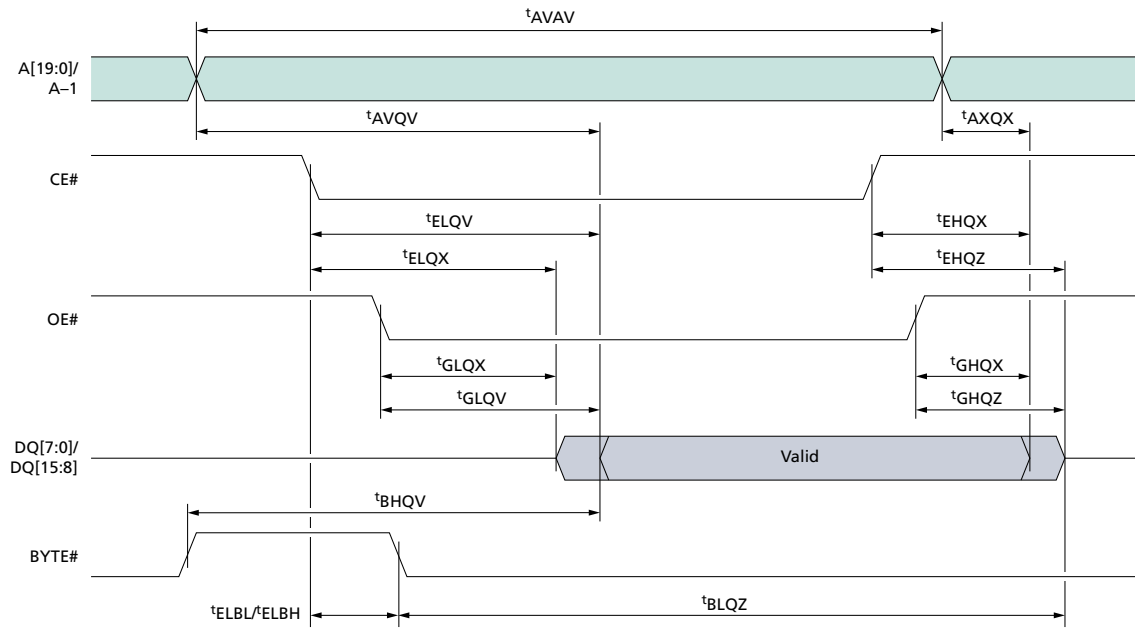
Figure 25: Read Mode AC Waveforms

Table 19: Read AC Characteristics

Symbol	Alt	Parameter	Test Condition	M29F160F		Unit
					55/5A	
t_{AVAV}	t_{RC}	Address Valid to Next Address Valid	$CE\# = V_{IL}, OE\# = V_{IL}$	Min	55	ns
t_{AVQV}	t_{ACC}	Address Valid to Output Valid	$CE\# = V_{IL}, OE\# = V_{IL}$	Max	55	ns
t_{ELQX}	t_{LZ}	Chip Enable Low to Output Transition	$OE\# = V_{IL}$	Min	0	ns
t_{ELQV}	t_{CE}	Chip Enable Low to Output Valid	$OE\# = V_{IL}$	Max	55	ns
t_{GLQX}	t_{OLZ}	Output Enable Low to Output Transition	$CE\# = V_{IL}$	Min	0	ns
t_{GLQV}	t_{OE}	Output Enable Low to Output Valid	$CE\# = V_{IL}$	Max	20	ns
t_{EHQZ}	t_{HZ}	Chip Enable High to Output Hi-Z	$OE\# = V_{IL}$	Max	15	ns
t_{GHQZ}	t_{DF}	Output Enable High to Output Hi-Z	$CE\# = V_{IL}$	Max	15	ns
t_{EHQX} t_{GHQX} t_{AXQX}	t_{OH}	Chip Enable, Output Enable or Address Transition to Output Transition	—	Min	0	ns

Table 19: Read AC Characteristics (Continued)

Symbol	Alt	Parameter	Test Condition	M29F160F		Unit
				55/5A		
t_{ELBL} t_{ELBH}	t_{ELFL} t_{ELFH}	Chip Enable to BYTE# Low or High	–	Max	3	ns
t_{BLQZ}	t_{FLQZ}	BYTE# Low to Output Hi-Z	–	Max	15	ns
t_{BHQV}	t_{FHQV}	BYTE# High to Output Valid	–	Max	20	ns

Note: 1. t_{ELQX} t_{GLQX} t_{EHQZ} and t_{GHQZ} parameters: Sampled only, not 100% tested.

AC Write Characteristics

Figure 26: Write AC Waveforms, Write Enable Controlled

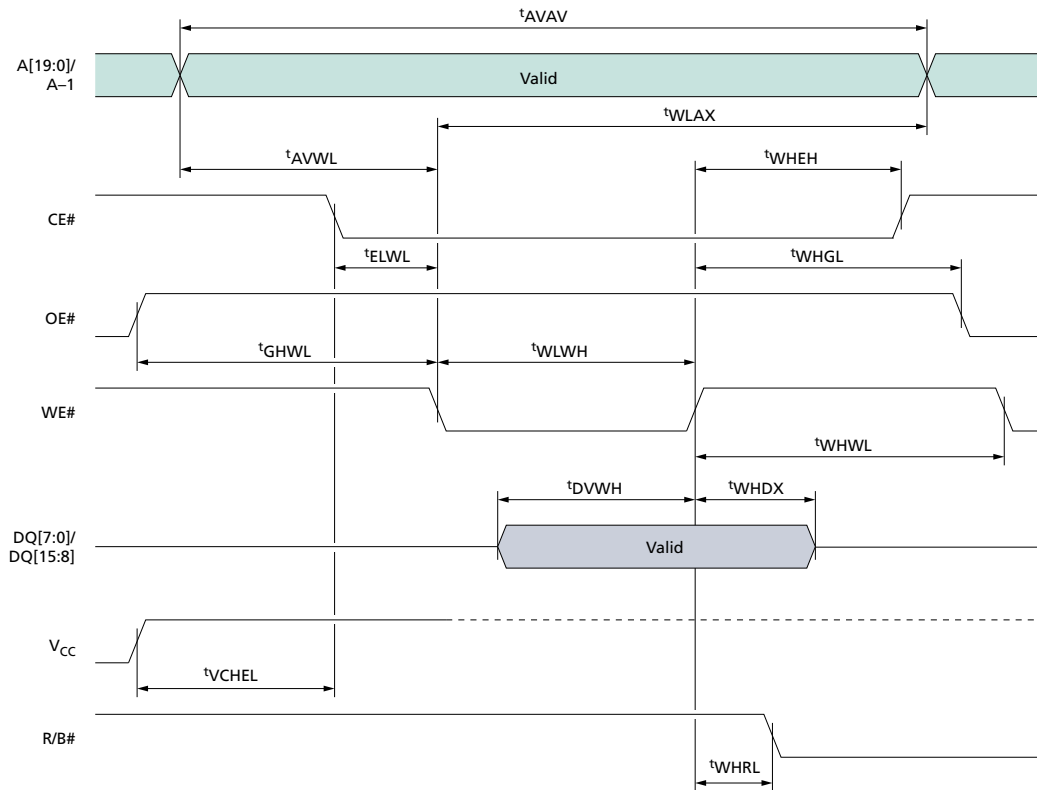

Table 20: Write AC Characteristics, Write Enable Controlled

Symbol	Alternate	Parameter	M29F160F		Unit
			55/5A		
t_{AVAV}	t_{WC}	Address Valid to Next Address Valid	Min	55	ns
t_{ELWL}	t_{CS}	Chip Enable Low to Write Enable Low	Min	0	ns
t_{WLWH}	t_{WP}	Write Enable Low to Write Enable High	Min	30	ns
t_{DWWH}	t_{DS}	Input Valid to Write Enable High	Min	20	ns
t_{WHDX}	t_{DH}	Write Enable High to Input Transition	Min	0	ns
t_{WHEH}	t_{CH}	Write Enable High to Chip Enable High	Min	0	ns
t_{WHWL}	t_{WPH}	Write Enable High to Write Enable Low	Min	15	ns
t_{AVWL}	t_{AS}	Address Valid to Write Enable Low	Min	0	ns
t_{WLAX}	t_{AH}	Write Enable Low to Address Transition	Min	30	ns
t_{GHWL}		Output Enable High to Write Enable Low	Min	0	ns
t_{WHGL}	t_{OEHL}	Write Enable High to Output Enable Low	Min	0	ns
t_{WHRL}	t_{BUSY}	Program/Erase Valid to RB# Low	Max	20	ns

Table 20: Write AC Characteristics, Write Enable Controlled (Continued)

Symbol	Alternate	Parameter	M29F160F		Unit
			55/5A		
t_{VCHL}	t_{VCS}	V_{CC} High to Chip Enable Low	Min	50	μs

Note: 1. t_{WHRL} parameter: Sampled only, not 100% tested.

Figure 27: Write AC Waveforms, Chip Enable Controlled

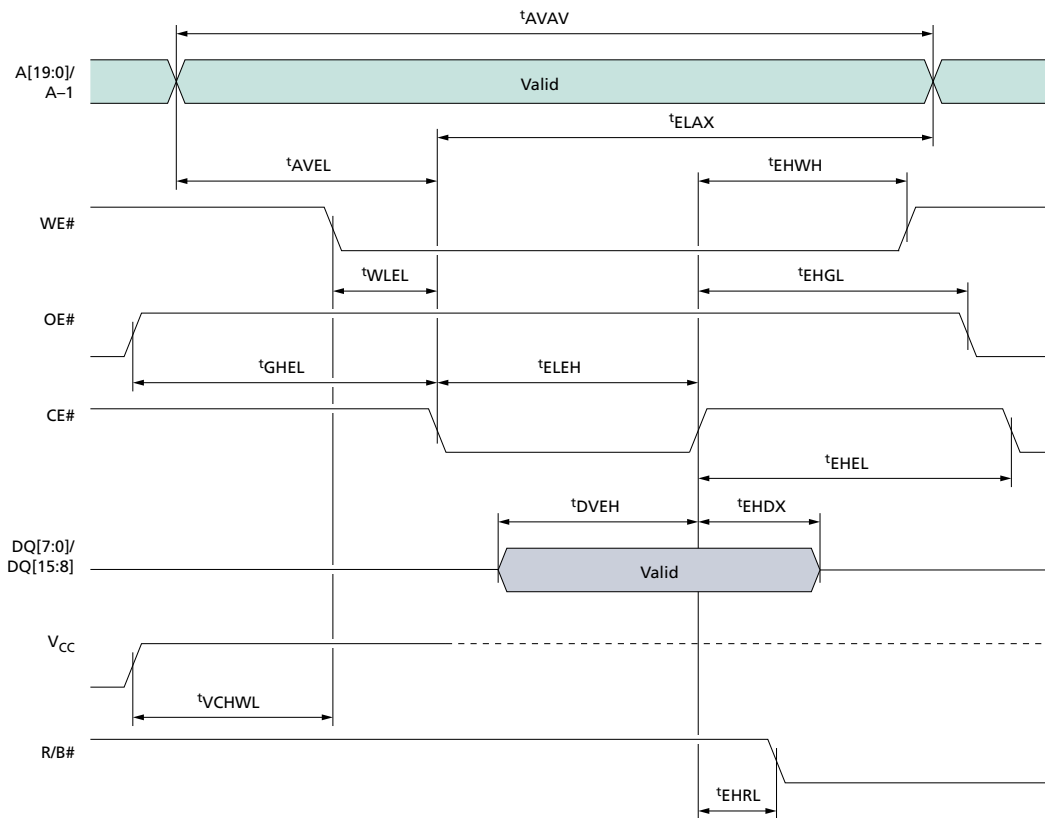

Table 21: Write AC Characteristics, Chip Enable Controlled

Symbol	Alt	Parameter	M29F160F		Unit
			55/5A		
t_{AVAV}	t_{WC}	Address Valid to Next Address Valid	Min	55	ns
t_{WLEL}	t_{WS}	Write Enable Low to Chip Enable Low	Min	0	ns
t_{ELEH}	t_{CP}	Chip Enable Low to Chip Enable High	Min	30	ns
t_{DVEH}	t_{DS}	Input Valid to Chip Enable High	Min	20	ns
t_{EHDX}	t_{DH}	Chip Enable High to Input Transition	Min	0	ns
t_{EHWH}	t_{WH}	Chip Enable High to Write Enable High	Min	0	ns

Table 21: Write AC Characteristics, Chip Enable Controlled (Continued)

Symbol	Alt	Parameter	M29F160F		Unit
			55/5A		
$t_{EH\text{EL}}$	t_{CPH}	Chip Enable High to Chip Enable Low	Min	15	ns
$t_{A\text{VEL}}$	t_{AS}	Address Valid to Chip Enable Low	Min	0	ns
t_{ELAX}	t_{AH}	Chip Enable Low to Address Transition	Min	30	ns
$t_{GH\text{EL}}$		Output Enable High Chip Enable Low	Min	0	ns
$t_{EH\text{GL}}$	$t_{OE\text{H}}$	Chip Enable High to Output Enable Low	Min	0	ns
$t_{EH\text{RL}}$	t_{BUSY}	Program/Erase Valid to RB# Low	Max	20	ns
$t_{VCH\text{WL}}$	t_{VCS}	V_{CC} High to Write Enable Low	Min	50	μs

Note: 1. $t_{EH\text{RL}}$ parameter: Sampled only, not 100% tested.

Reset Specifications

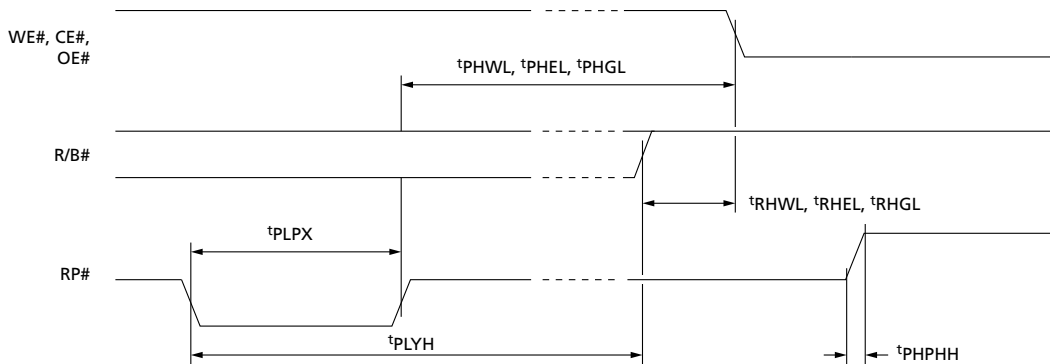
Figure 28: Reset/Block Temporary Unprotect AC Waveforms

Table 22: Reset/Block Temporary Unprotect AC Characteristics

Symbol	Alt	Parameter	M29F160F		Unit
			55/5A		
$t_{PH\text{WL}}$ $t_{PHE\text{L}}$ $t_{PH\text{GL}}$	t_{RH}	RP# High to Write Enable Low, Chip Enable Low, Output Enable Low	Min	50	ns
$t_{RH\text{WL}}$ $t_{RHE\text{L}}$ $t_{RH\text{GL}}$	t_{RB}	RB# High to Write Enable Low, Chip Enable Low, Output Enable Low	Min	0	ns
t_{PLPX}	t_{RP}	RP# Pulse Width	Min	500	ns
t_{PLYH}	$t_{RE\text{ADY}}$	RP# Low to Read Mode	Max	10	μs
$t_{PH\text{PH}}$	$t_{VI\text{DR}}$	RP# Rise Time to V_{ID}	Min	500	ns

Note: 1. $t_{PH\text{WL}}$ $t_{PH\text{GL}}$ $t_{RH\text{WL}}$ $t_{RHE\text{L}}$ $t_{RH\text{GL}}$ t_{PLYH} and $t_{PH\text{PH}}$ parameters: Sampled only, not 100% tested.

PROGRAM/ERASE Characteristics

Table 23: Program/Erase Characteristics

Parameter		Min	Typ	Max	Unit
Chip erase	M29F160F	—	25	120	s
	M29F800F		12	60	
	M29F400F		6	30	
	M29F200F		3	15	
Block erase (64KB)		—	0.8	6	s
Erase suspend latency time		—	20	25	μs
Program (byte or word)		—	11	200	μs
Chip program (byte-by-byte)	M29F160F	—	24	120	s
	M29F800F		12	60	
	M29F400F		6	30	
	M29F200F		4	16	
Chip program (word-by-word)	M29F160F	—	12	60	s
	M29F800F		6	30	
	M29F400F		3	15	
	M29F200F		2	8	
PROGRAM/ERASE cycles (per block)		100,000	—	—	cycles
Data retention		20	—	—	years

- Notes:
1. Typical values are measured at room temperature and nominal voltages; typical and maximum values are samples, not 100% tested.
 2. Chip erase, program, and chip program parameters: Maximum value measured at worst case conditions for both temperature and V_{CC} after 100,000 PROGRAM/ERASE cycles.
 3. Block erase and erase suspend latency parameter: Maximum value measured at worst-case conditions for both temperature and V_{CC} .

Package Dimensions

Figure 29: 48-Lead TSOP – 12mm x 20mm

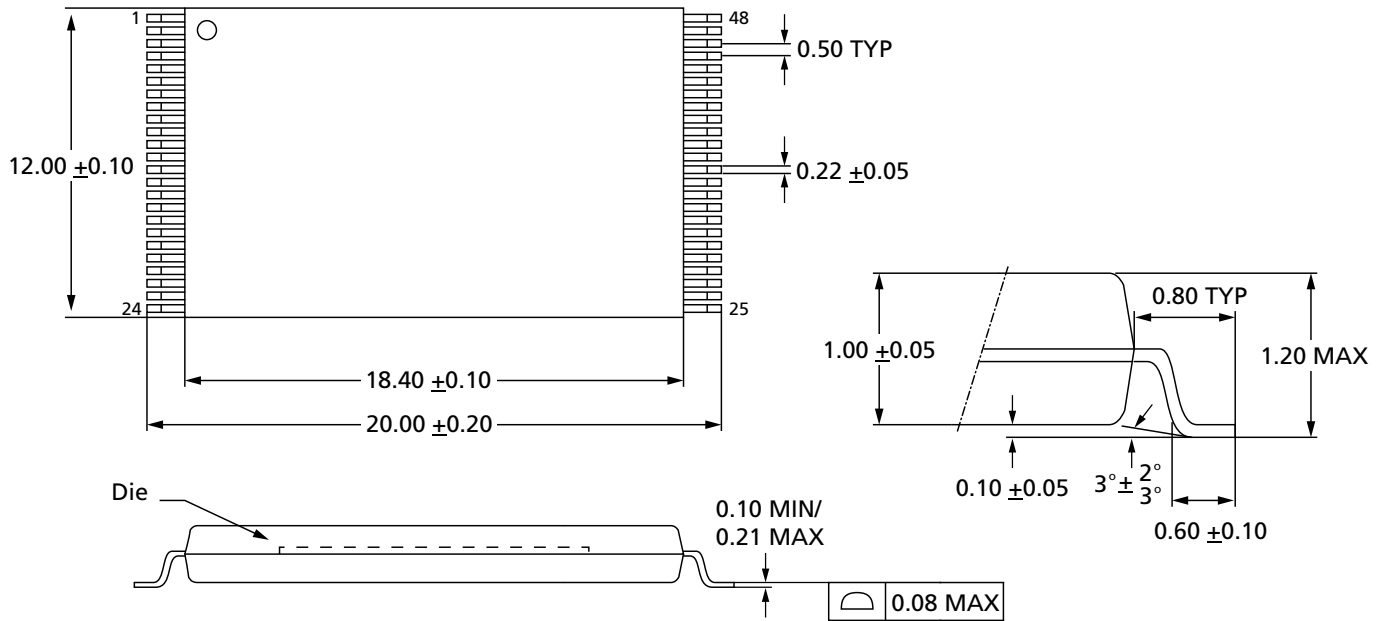

Note: 1. Drawing is not to scale.

Figure 30: 44-Lead Small-Outline – 500 Mil

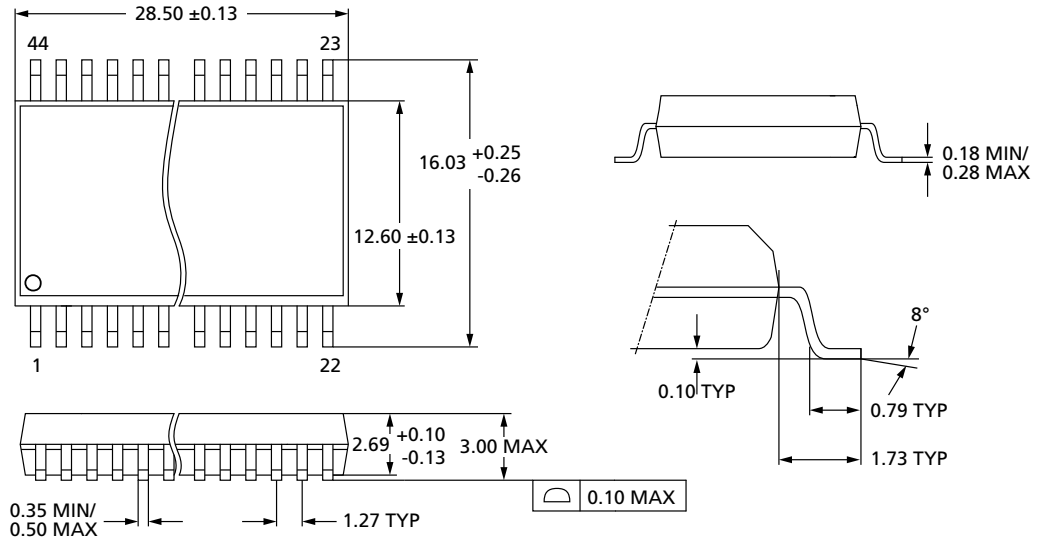

Note: 1. Drawing is not to scale.

Revision History

Rev. C – 5/18

- Added Important Notes and Warnings section for further clarification aligning to industry standards

Rev. B – 2/14

- In Block and Chip Protection section, added block protect and chip unprotect flowcharts

Rev. A – 2/13

- Initial Micron brand release

8000 S. Federal Way, P.O. Box 6, Boise, ID 83707-0006, Tel: 208-368-4000
www.micron.com/products/support Sales inquiries: 800-932-4992
Micron and the Micron logo are trademarks of Micron Technology, Inc.
All other trademarks are the property of their respective owners.

This data sheet contains minimum and maximum limits specified over the power supply and temperature range set forth herein. Although considered final, these specifications are subject to change, as further product development and data characterization sometimes occur.

X-ON Electronics

Largest Supplier of Electrical and Electronic Components

Click to view similar products for [NOR Flash](#) category:

Click to view products by [Micron](#) manufacturer:

Other Similar products are found below :

[AM29BL162CB-80RDPE1](#) [AM29F800BT-90DPE 2](#) [S29AL016J70BFI012](#) [S29AL016J70FFI022](#) [S29GL064N90BFI032](#)
[S29GL064N90BFI042](#) [S29GL064N90FFI012](#) [S29GL128P10FFI022](#) [S29GL256P11FFIV12](#) [S29GL256P11FFIV22](#) [S29GL512S10GHI020](#)
[S70FL01GSAGMFV011](#) [S99-50389 P](#) [AM29F016D-120DPI 1](#) [AT25DF011-SSHN-T](#) [AT25DF011-XMHN-T](#) [AT25DF041B-MHN-Y](#)
[AT25DN256-SSHF-T](#) [AT25DN512C-MAHF-T](#) [AT45DB161E-CCUD-T](#) [S29AL008J55BFIR22](#) [S29GL032N90TFI033](#) [S29GL032N90TFI043](#)
[S29GL256P11FFI012](#) [S29JL064J55TFI003](#) [S70FL01GSAGMFI013](#) [S99-50052](#) [S29AL008J55BFIR23](#) [M29W128GL70ZS3F](#)
[PC28F128J3F75B](#) [S29GL128P10TFI013](#) [S29GL064N90FFI022](#) [S29GL032N11FFIS12](#) [S29AL016D90DGI027](#) [S29JL032J70TFI423](#)
[S29GL128S10TFIV13](#) [S29AL016J70WEI029](#) [S25FL132K0XMFB043](#) [AT25DF041B-SSHNHR-T](#) [S25FL116K0XNFB010](#)
[S25FL132K0XBHA020](#) [AT25SL321-MBUE-T](#) [SST39VF800A-70-4I-MAQE](#) [LE25S40MB-AH](#) [S25FL116K0XNFA013](#) [SST39VF400A-70-](#)
[4C-MAQE](#) [AT25DF512C-XMHN-T](#) [S25FL256LAGMFI001](#) [S26KL128SDABHN020](#) [520366231286](#)