

e-MMC Memory

MTFC4GACAAAM-4M IT, MTFC8GACAAAM-4M IT

Features

- MultiMediaCard (MMC) controller and NAND Flash
- 153-ball VFBGA (RoHS compliant, "green" package)
- V_{CC} : 2.7–3.6V
- V_{CCQ} (dual voltage): 1.65–1.95V; 2.7–3.6V
- Temperature ranges
 - Operating temperature: -40°C to $+85^{\circ}\text{C}$
 - Storage temperature: -40°C to $+85^{\circ}\text{C}$

MMC-Specific Features

- JEDEC/MMC standard version 4.51-compliant (JEDEC Standard No. 84-B451) – SPI mode not supported 1
 - Advanced 11-signal interface
 - x1, x4, and x8 I/Os, selectable by host
 - SDR/DDR modes up to 52 MHz clock speed
 - HS200 mode
 - Real-time clock
 - Command classes: class 0 (basic); class 2 (block read); class 4 (block write); class 5 (erase); class 6 (write protection); class 7 (lock card)
 - Temporary write protection
 - Boot operation (high-speed boot)
 - Sleep mode
 - Replay-protected memory block (RPMB)
 - Secure erase and secure trim
 - Hardware reset signal
 - Multiple partitions with enhanced attribute
 - Permanent and power-on write protection
 - High-priority interrupt (HPI)

Figure 1: Micron e-MMC Device

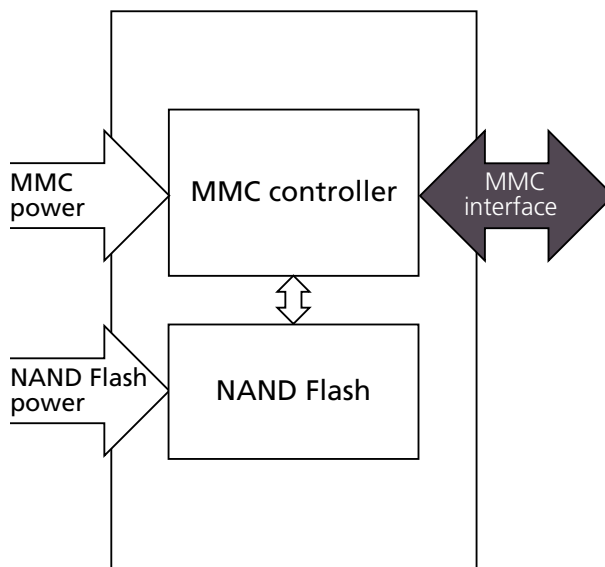

MMC-Specific Features (Continued)

- Background operation
- Reliable write
- Discard and sanitize
- Extended partitioning
- Context ID
- Data TAG
- Packed commands
- Dynamic device capacity
- Backward compatible with previous MMC
- Thermal specification
- Cache
- ECC and block management implemented

Note: 1. The JEDEC specification is available at www.jedec.org/sites/default/files/docs/JESD84-B451.pdf.



e-MMC Performance and Current Consumption

Table 1: MLC Partition Performance

Condition ¹	Typical Values		Unit
	4GB	8GB	
Sequential Write	11	24	MB/s
Sequential Read	80	120	MB/s
Random Write	1000	1000	IOPS
Random Read	4000	4000	IOPS

Note: 1. Bus in x8 I/O and HS200 modes. Sequential access of 1MB chunk; random access of 4KB chunk over 1GB span. Additional performance data, such as system performance on a specific application board, will be provided in a separate document upon customer request.

Table 2: 52 MHz DDR2 Performance

Condition ¹	Typical Values		Unit
	4GB	8GB	
Sequential Write	11	24	MB/s
Sequential Read	75	80	MB/s
Random Write	1000	1000	IOPS
Random Read	3800	3800	IOPS

Note: 1. Bus in x8 I/O and 52 MHz DDR2 modes. Sequential access of 1MB chunk; random access of 4KB chunk over 1GB span. Additional performance data, such as system performance on a specific application board, will be provided in a separate document upon customer request.

Table 3: Current Consumption

Condition ¹	Typical Values (I _{CC} /I _{CCQ})		Unit
	4GB	8GB	
Write	50/20	60/20	mA
Read	60/60	60/60	mA
Sleep	0/180	0/180	uA
Auto-Standby	25/150	50/180	uA

Note: 1. Bus in x8 I/O and HS200 modes. V_{CC} = 3.6V and V_{CCQ} = 1.95V. 25°C. Measurements done as average RMS current consumption. I_{CCQ} in READ operation might be affected by tester load.



Part Numbering Information

Micron® e-MMC memory devices are available in different configurations and densities.

Figure 2: e-MMC Part Numbering

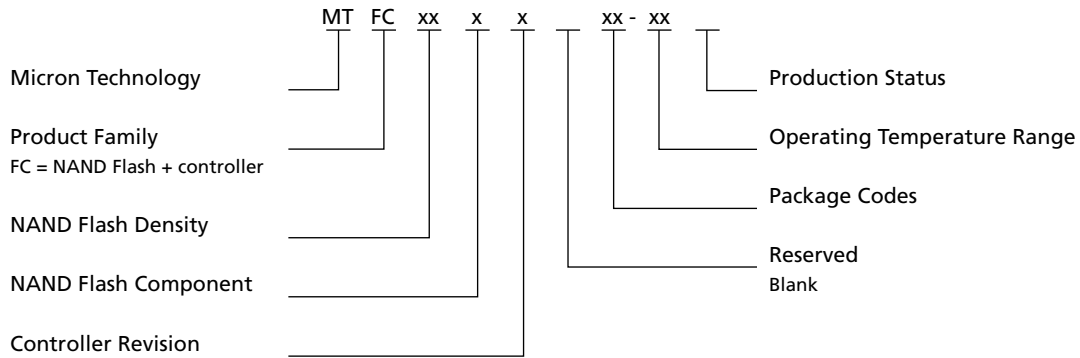

Table 4: Ordering Information

Base Part Number	Density	Package	Shipping
MTFC4GACAAAM-4M IT	4GB	153-ball VFBGA 11.5mm x 13.0mm x 1.0mm	Tray
			Tape and reel
MTFC8GACAAAM-4M IT	8GB	153-ball VFBGA 11.5mm x 13.0mm x 1.0mm	Tray
			Tape and reel

Device Marking

Due to the size of the package, the Micron-standard part number is not printed on the top of the device. Instead, an abbreviated device mark consisting of a 5-digit alphanumeric code is used. The abbreviated device marks are cross-referenced to the Micron part numbers at the FBGA Part Marking Decoder site: www.micron.com/decoder.



General Description

Micron *e*-MMC is a communication and mass data storage device that includes a Multi-MediaCard (MMC) interface, a NAND Flash component, and a controller on an advanced 11-signal bus, which is compliant with the MMC system specification. Its low cost, small size, Flash technology independence, and high data throughput make *e*-MMC ideal for smartphones, digital cameras, PDAs, MP3s, and other portable applications.

The nonvolatile *e*-MMC draws no power to maintain stored data, delivers high performance across a wide range of operating temperatures, and resists shock and vibration disruption.



Signal Descriptions

Table 5: Signal Descriptions

Symbol	Type	Description
CLK	Input	Clock: Each cycle of the clock directs a transfer on the command line and on the data line(s). The frequency can vary between the minimum and the maximum clock frequency.
RST_n	Input	Reset: The RST_n signal is used by the host for resetting the device, moving the device to the pre-idle state. By default, the RST_n signal is temporarily disabled in the device. The host must set ECSD register byte 162, bits[1:0] to 0x1 to enable this functionality before the host can use it.
CMD	I/O	Command: This signal is a bidirectional command channel used for command and response transfers. The CMD signal has two bus modes: open-drain mode and push-pull mode (see Operating Modes). Commands are sent from the MMC host to the device, and responses are sent from the device to the host.
DAT[7:0]	I/O	Data I/O: These are bidirectional data signals. The DAT signals operate in push-pull mode. By default, after power-on or assertion of the RST_n signal, only DAT0 is used for data transfer. The MMC controller can configure a wider data bus for data transfer either using DAT[3:0] (4-bit mode) or DAT[7:0] (8-bit mode). e-MMC includes internal pull-up resistors for data lines DAT[7:1]. Immediately after entering the 4-bit mode, the device disconnects the internal pull-up resistors on the DAT[3:1] lines. Upon entering the 8-bit mode, the device disconnects the internal pull-ups on the DAT[7:1] lines.
V _{CC}	Supply	V _{CC} : NAND interface (I/F) I/O and NAND Flash power supply.
V _{CCQ}	Supply	V _{CCQ} : e-MMC controller core and e-MMC I/F I/O power supply.
V _{SS} ¹	Supply	V _{SS} : NAND I/F I/O and NAND Flash ground connection.
V _{SSQ} ¹	Supply	V _{SSQ} : e-MMC controller core and e-MMC I/F ground connection.
V _{DDIM}		Internal voltage node: At least a 0.1µF capacitor is required to connect V _{DDIM} to ground. A 1µF capacitor is recommended. Do not tie to supply voltage or ground.
NC	–	No connect: No internal connection is present.
RFU	–	Reserved for future use: No internal connection is present. Leave it floating externally.

Note: 1. V_{SS} and V_{SSQ} are connected internally.



153-Ball Signal Assignments

Figure 3: 153 Ball (Top View, Ball Down)

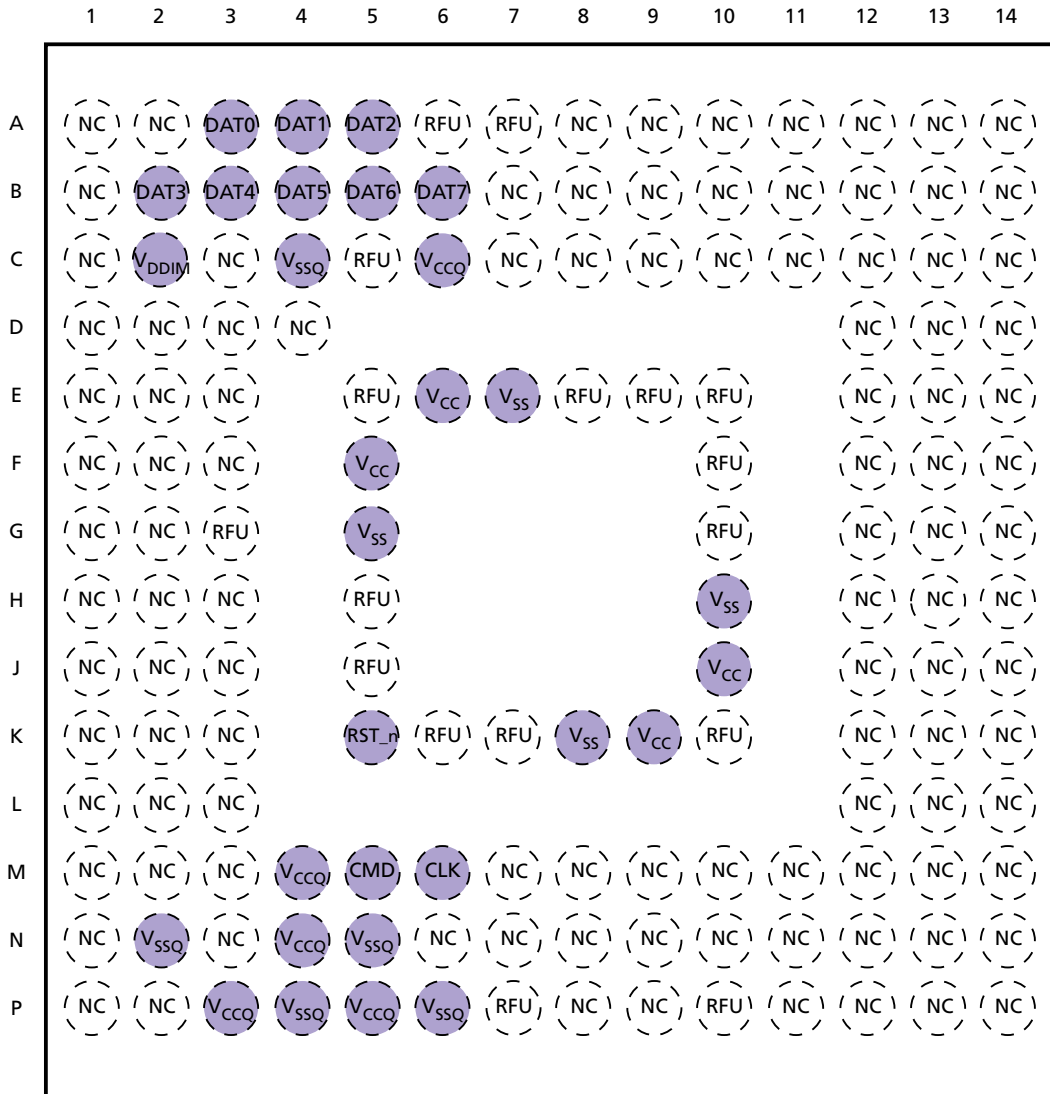

- Notes:
1. Some previous versions of the JEDEC product or mechanical specification had defined reserved for future use (RFU) balls as no connect (NC) balls. NC balls assigned in the previous specifications could have been connected to ground on the system board. To enable new feature introduction, some of these balls are assigned as RFU in the v4.4 mechanical specification. Any new PCB footprint implementations should use the new ball assignments and leave the RFU balls floating on the system board.
 2. V_{CC}, V_{CCQ}, V_{SS}, and V_{SSQ} balls must all be connected on the system board.



Package Dimensions

Figure 4: 153-Ball VFBGA – 11.50mm x 13.00mm x 1.00mm (Package Code: AM)

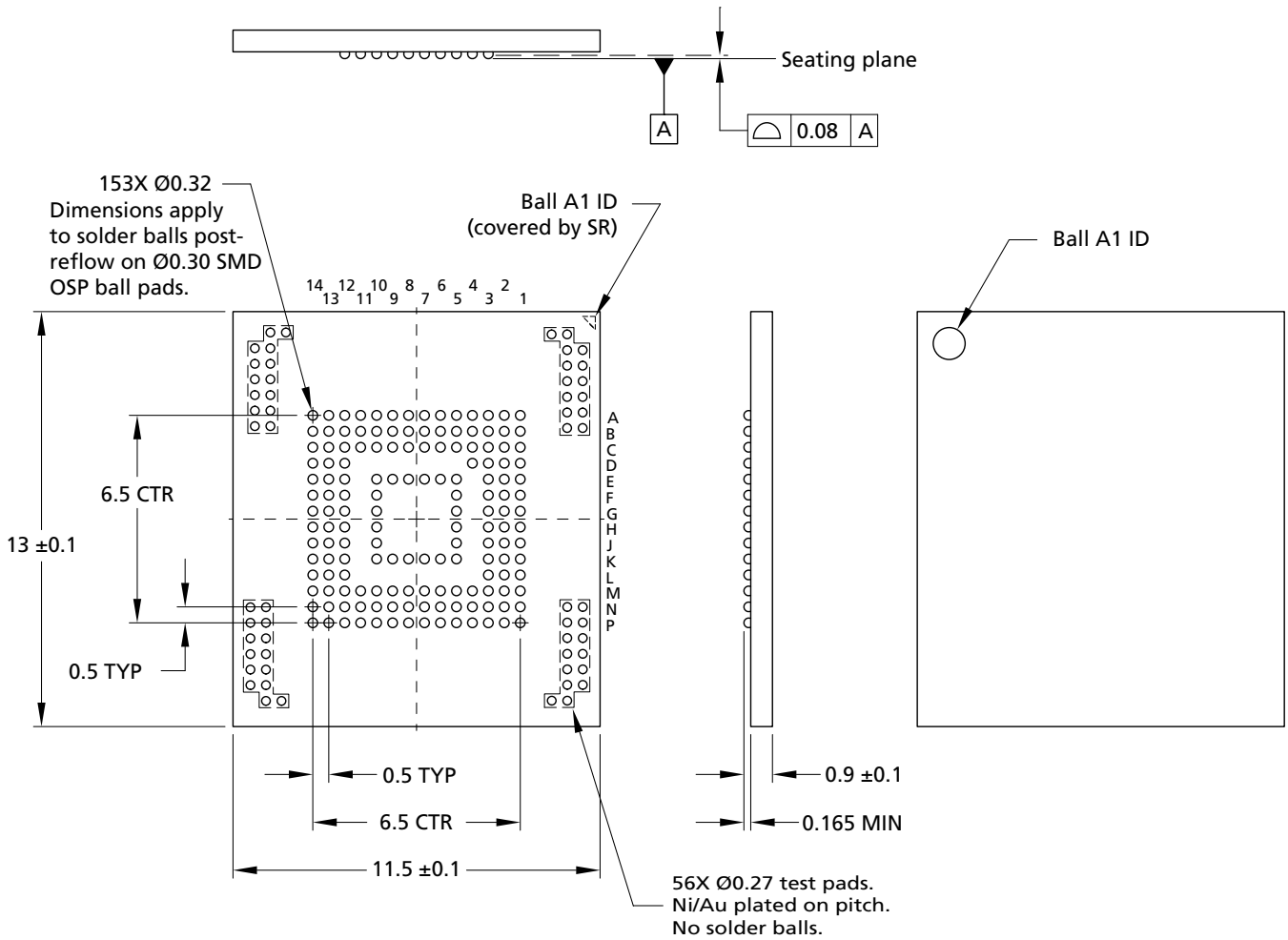

Note: 1. Dimensions are in millimeters.

Architecture

Figure 5: e-MMC Functional Block Diagram

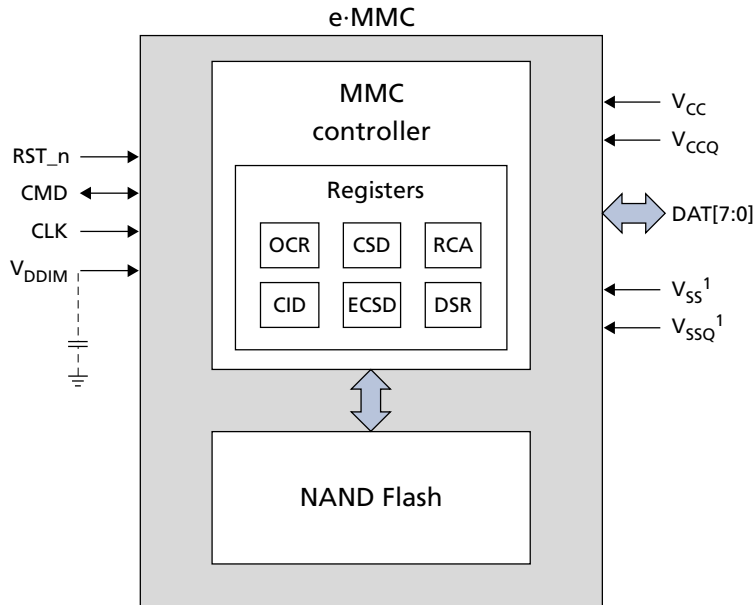

Note: 1. V_{SS} and V_{SSQ} are internally connected.

MMC Protocol Independent of NAND Flash Technology

The MMC specification defines the communication protocol between a host and a device. The protocol is independent of the NAND Flash features included in the device. The device has an intelligent on-board controller that manages the MMC communication protocol.

The controller also handles block management functions such as logical block allocation and wear leveling. These management functions require complex algorithms and depend entirely on NAND Flash technology (generation or memory cell type).

The device handles these management functions internally, making them invisible to the host processor.

Defect and Error Management

Micron e-MMC incorporates advanced technology for defect and error management. If a defective block is identified, the device completely replaces the defective block with one of the spare blocks. This process is invisible to the host and does not affect data space allocated for the user.

The device also includes a built-in error correction code (ECC) algorithm to ensure that data integrity is maintained.

To make the best use of these advanced technologies and ensure proper data loading and storage over the life of the device, the host must exercise the following precautions:

- Check the status after WRITE, READ, and ERASE operations.
- Avoid power-down during WRITE and ERASE operations.



OCR Register

The 32-bit operation conditions register (OCR) stores the V_{DD} voltage profile of the card and the access mode indication. In addition, this register includes a status information bit.

Table 6: OCR Parameters

OCR Bits	OCR Value	Description
[31]	1b (ready)/0b (busy) ¹	Device power-on status bit
[30:29]	10b	Sector mode
[28:24]	0 0000b	Reserved
[23:15]	1 1111 1111b	V_{DD} : 2.7–3.6V range
[14:8]	000 0000b	V_{DD} : 2.0–2.7V range
[7]	1b	V_{DD} : 1.70–1.95V range
[6:0]	000 0000b	Reserved

Note: 1. OCR = C0FF8080h after the device has completed power-up.



CID Register

The card identification (CID) register is 128 bits wide. It contains the device identification information used during the card identification phase as required by *e*-MMC protocol. Each device is created with a unique identification number.

Table 7: CID Register Field Parameters

Name	Field	Width	CID Bits	CID Value
Manufacturer ID	MID	8	[127:120]	FEh
Reserved	–	6	[119:114]	–
Card/BGA	CBX	2	[113:112]	01h
OEM/application ID	OID	8	[111:104]	4Eh
Product name	PNM	48	[103:56]	P1xxxx
Product revision	PRV	8	[55:48]	–
Product serial number	PSN	32	[47:16]	–
Manufacturing date	MDT	8	[15:8]	–
CRC7 checksum	CRC	7	[7:1]	–
Not used; always 1	–	1	0	–



CSD Register

The card-specific data (CSD) register provides information about accessing the device contents. The CSD register defines the data format, error correction type, maximum data access time, and data transfer speed, as well as whether the DSR register can be used. The programmable part of the register (entries marked with W or E in the following table) can be changed by the PROGRAM_CSD (CMD27) command.

Table 8: CSD Register Field Parameters

Name	Field	Size (Bits)	Cell Type ¹	CSD Bits	CSD Value
CSD structure	CSD_STRUCTURE	2	R	[127:126]	03h
System specification version	SPEC_VERS	4	R	[125:122]	04h
Reserved ²	–	2	–	[121:120]	–
Data read access time 1	TAAC	8	R	[119:112]	4Fh
Data read access time 2 in CLK cycles (NSAC × 100)	NSAC	8	R	[111:104]	01h
Maximum bus clock frequency	TRAN_SPEED	8	R	[103:96]	32h
Card command classes ³	CCC	12	R	[95:84]	0F5h
Maximum read data block length	READ_BL_LEN	4	R	[83:80]	09h
Partial blocks for reads supported	READ_BL_PARTIAL	1	R	[79]	0h
Write block misalignment	WRITE_BLK_MISALIGN	1	R	[78]	0h
Read block misalignment	READ_BLK_MISALIGN	1	R	[77]	0h
DSR implemented ⁴	DSR_IMP	1	R	[76]	1h
Reserved	–	2	–	[75:74]	–
Device size	C_SIZE	12	R	[73:62]	FFFh
Maximum read current at V _{DD,min}	VDD_R_CURR_MIN	3	R	[61:59]	07h
Maximum read current at V _{DD,max}	VDD_R_CURR_MAX	3	R	[58:56]	07h
Maximum write current at V _{DD,min}	VDD_W_CURR_MIN	3	R	[55:53]	07h
Maximum write current at V _{DD,max}	VDD_W_CURR_MAX	3	R	[52:50]	07h
Device size multiplier	C_SIZE_MULT	3	R	[49:47]	07h
Erase group size	ERASE_GRP_SIZE	5	R	[46:42]	1Fh
Erase group size multiplier	ERASE_GRP_MULT	5	R	[41:37]	1Fh
Write protect group size	WP_GRP_SIZE	4GB	R	[36:32]	07h
		8GB			0Fh
		16GB			1Fh
Write protect group enable	WP_GRP_ENABLE	1	R	[31]	1h
Manufacturer default ECC	DEFAULT_ECC	2	R	[30:29]	00h
Write-speed factor	R2W_FACTOR	3	R	[28:26]	02h
Maximum write data block length	WRITE_BL_LEN	4	R	[25:22]	09h
Partial blocks for writes supported	WRITE_BL_PARTIAL	1	R	[21]	0h
Reserved	–	4	–	[20:17]	–
Content protection application	CONTENT_PROT_APP	1	R	[16]	0h

Table 8: CSD Register Field Parameters (Continued)

Name	Field	Size (Bits)	Cell Type ¹	CSD Bits	CSD Value
File-format group	FILE_FORMAT_GRP	1	R/W	[15]	0h
Copy flag (OTP)	COPY	1	R/W	[14]	0h
Permanent write protection	PERM_WRITE_PROTECT	1	R/W	[13]	0h
Temporary write protection	TMP_WRITE_PROTECT	1	R/W/E	[12]	0h
File format	FILE_FORMAT	2	R/W	[11:10]	00h
ECC	ECC	2	R/W/E	[9:8]	00h
CRC	CRC	4GB	R/W/E	[7:1]	47h
		8GB			5Fh
		16GB			6Fh
Reserved	–	1	–	[0]	–

- Notes:
1. R = Read-only;
R/W = One-time programmable and readable;
R/W/E = Multiple writable with value kept after a power cycle, assertion of the RST_n signal, and any CMD0 reset, and readable
 2. Reserved bits should be read as 0.
 3. CM0 restriction: CMD0 (SW RESET) is not supported during programming command. If SW RESET is issued during programming commands, a power cycle is required.
 4. The $I_{PEAK, max}$ driving capability can be modified according to the actual capacitive load on the e-MMC interface signals in the user application board, using CMD4. In HS200 mode, the driver strength value is set in EXT_CSD[185], using CMD6.

CMD4 Argument	Driving Capability (mA)
0x01000000	4
0x02000000	8
0x04000000	12 (default)
0x08000000	16
0x10000000	20
0x20000000	24
0x40000000	28
0x80000000	32



ECSD Register

The 512-byte extended card-specific data (ECSD) register defines device properties and selected modes. The most significant 320 bytes are the properties segment. This segment defines device capabilities and cannot be modified by the host. The lower 192 bytes are the modes segment. The modes segment defines the configuration in which the device is working. The host can change the properties of modes segments using the SWITCH command.

Table 9: ECSD Register Field Parameters

Name	Field	Size (Bytes)	Cell Type ¹	ECSD Bytes	ECSD Value	
Properties Segment						
Reserved ²	–	6	–	[511:506]	–	
Extended security protocol	EXT_SECURITY_ERR	1	R	[505]	00h	
Supported command sets	S_CMD_SET	1	R	[504]	01h	
HPI features	HPI_FEATURES	1	R	[503]	03h	
Background operations support	BKOPS_SUPPORT	1	R	[502]	01h	
Max-packed read commands	MAX_PACKED_READS	1	R	[501]	3Ch	
Max-packed write commands	MAX_PACKED_WRITES	1	R	[500]	3Ch	
Data tag support	DATA_TAG_SUPPORT	1	R	[499]	01h	
Tag unit size	TAG_UNIT_SIZE	1	R	[498]	03h	
Tag resources size	TAG_RES_SIZE	1	R	[497]	00h	
Context management capabilities	CONTEXT_CAPABILITIES	1	R	[496]	05h	
Large unit size	LARGE_UNIT_SIZE_M1	4GB	1	R	[495]	03h
		8GB			07h	
Extended partitions attribute support	EXT_SUPPORT	1	R	[494]	03h	
Reserved	–	241	–	[493:253]	–	
Cache size	CACHE_SIZE	4	R	[252:249]	00000020h	
Generic CMD6 timeout	GENERIC_CMD6_TIME	1	R	[248]	19h	
Power-off notification (long) timeout	POWER_OFF_LONG_TIME	1	R	[247]	FFh	
Background operations status	BKOPS_STATUS	1	R	[246]	00h	
Number of correctly programmed sectors	CORRECTLY_PROG_SECTORS_NUM	4	R	[245:242]	00000000h	
First initialization time after partitioning (first CMD1 to device ready)	INI_TIMEOUT_AP	1	R	[241]	32h	
Reserved	–	1	–	[240]	–	
Power class for 52 MHz, DDR at 3.6V	PWR_CL_DDR_52_360	1	R	[239]	04h	
Power class for 52 MHz, DDR at 1.95V	PWR_CL_DDR_52_195	1	R	[238]	09h	
Power class for 200 MHz at 1.95V	PWR_CL_200_195	1	R	[237]	09h	
Power class for 200 MHz, at 1.3V	PWR_CL_200_130	1	R	[236]	00h	
Minimum write performance for 8-bit at 52 MHz in DDR mode	MIN_PERF_DDR_W_8_52	1	R	[235]	00h	

Table 9: ECSD Register Field Parameters (Continued)

Name	Field	Size (Bytes)	Cell Type ¹	ECSD Bytes	ECSD Value	
Minimum read performance for 8-bit at 52 MHz in DDR mode	MIN_PERF_DDR_R_8_52	1	R	[234]	00h	
Reserved	–	1	–	[233]	–	
TRIM multiplier	TRIM_MULT	1	R	[232]	03h	
Secure feature support	SEC_FEATURE_SUPPORT	1	R	[231]	55h	
Secure erase multiplier	SEC_ERASE_MULT	1	R	[230]	06h	
Secure trim multiplier	SEC_TRIM_MULT	1	R	[229]	09h	
Boot information	BOOT_INFO	1	R	[228]	07h	
Reserved	–	1	–	[227]	–	
Boot partition size	BOOT_SIZE_MULT	4GB	1	R	[226]	80h
		8GB				80h
Access size	ACC_SIZE	4GB	1	R	[225]	06h
		8GB				07h
High-capacity erase unit size	HC_ERASE_GRP_SIZE	4GB	1	R	[224]	08h
		8GB				10h
High-capacity erase timeout	ERASE_TIMEOUT_MULT	1	R	[223]	01h	
Reliable write-sector count	REL_WR_SEC_C	1	R	[222]	01h	
High-capacity write protect group size	HC_WP_GRP_SIZE	1	R	[221]	01h	
Sleep current (V _{CC})	S_C_VCC	1	R	[220]	06h	
Sleep current (V _{CCQ})	S_C_VCCQ	1	R	[219]	09h	
Reserved	–	1	–	[218]	–	
Sleep/awake timeout	S_A_TIMEOUT	1	R	[217]	10h	
Reserved	–	1	–	[216]	–	
Sector count	SEC_COUNT	4GB	4	R	[215:212]	00734000h
		8GB				00E68000h
Reserved	–	1	–	[211]	–	
Minimum write performance for 8-bit at 52 MHz	MIN_PERF_W_8_52	1	R	[210]	08h	
Minimum read performance for 8-bit at 52 MHz	MIN_PERF_R_8_52	1	R	[209]	08h	
Minimum write performance for 8-bit at 26 MHz and 4-bit at 52 MHz	MIN_PERF_W_8_26_4_52	1	R	[208]	08h	
Minimum read performance for 8-bit at 26 MHz and 4-bit at 52 MHz	MIN_PERF_R_8_26_4_52	1	R	[207]	08h	
Minimum write performance for 4-bit at 26 MHz	MIN_PERF_W_4_26	1	R	[206]	08h	
Minimum read performance for 4-bit at 26 MHz	MIN_PERF_R_4_26	1	R	[205]	08h	
Reserved	–	1	–	[204]	–	

Table 9: ECSD Register Field Parameters (Continued)

Name	Field	Size (Bytes)	Cell Type ¹	ECSD Bytes	ECSD Value
Power class for 26 MHz at 3.6V	PWR_CL_26_360	1	R	[203]	02h
Power class for 52 MHz at 3.6V	PWR_CL_52_360	1	R	[202]	02h
Power class for 26 MHz at 1.95V	PWR_CL_26_195	1	R	[201]	05h
Power class for 52 MHz at 1.95V	PWR_CL_52_195	1	R	[200]	05h
Partition switching timing	PARTITION_SWITCH_TIME	1	R	[199]	03h
Out-of-interrupt busy timing	OUT_OF_INTERRUPT_TIME	1	R	[198]	0Ah
I/O driver strength	DRIVER_STRENGTH	1	R	[197]	0Fh
Card type	CARD_TYPE	1	R	[196]	17h
Reserved	–	1	–	[195]	–
CSD structure version	CSD_STRUCTURE	1	R	[194]	02h
Reserved	–	1	–	[193]	–
Extended CSD revision	EXT_CSD_REV	1	R	[192]	06h
Modes Segment					
Command set	CMD_SET	1	R/W/E_P	[191]	00h
Reserved	–	1	–	[190]	–
Command set revision	CMD_SET_REV	1	R	[189]	00h
Reserved	–	1	–	[188]	–
Power class	POWER_CLASS	1	R/W/E_P	[187]	00h
Reserved	–	1	–	[186]	–
High-speed interface timing ⁴	HS_TIMING	1	R/W/E_P	[185]	00h
Reserved	–	1	–	[184]	–
Bus width mode	BUS_WIDTH	1	W/E_P	[183]	00h
Reserved	–	1	–	[182]	–
Erased memory content	ERASED_MEM_CONT	1	R	[181]	00h
Reserved	–	1	–	[180]	–
Partition configuration	PARTITION_CONFIG	1	R/W/E, R/W/E_P	[179]	00h
Boot configuration protection	BOOT_CONFIG_PROT	1	R/W, R/W/C_P	[178]	00h
Boot bus width	BOOT_BUS_WIDTH	1	R/W/E	[177]	00h
Reserved	–	1	–	[176]	–
High-density erase group definition	ERASE_GROUP_DEF	1	R/W/E_P	[175]	00h
Boot write protection status registers	BOOT_WP_STATUS	1	R	[174]	00h
Boot area write protection register	BOOT_WP	1	R/W, R/W/C_P	[173]	00h
Reserved	–	1	–	[172]	–

Table 9: ECSD Register Field Parameters (Continued)

Name	Field	Size (Bytes)	Cell Type ¹	ECSD Bytes	ECSD Value
User write protection register	USER_WP	1	R/W, R/W/C_P, R/W/E_P	[171]	00h
Reserved	–	1	–	[170]	–
Firmware configuration	FW_CONFIG	1	R/W	[169]	00h
RPMB size	RPMB_SIZE_MULT	1	R	[168]	01h
Write reliability setting register ³	WR_REL_SET	1	R/W	[167]	00h
Write reliability parameter register	WR_REL_PARAM	1	R	[166]	05h
SANITIZE START operation	SANITIZE_START	1	W/E_P	[165]	00h
Manually start background operations	BKOPS_START	1	W/E_P	[164]	00h
Enable background operations hand-shake	BKOPS_EN	1	R/W	[163]	00h
Hardware reset function	RST_n_FUNCTION	1	R/W	[162]	00h
HPI management	HPI_MGMT	1	R/W/E_P	[161]	00h
Partitioning support	PARTITIONING_SUPPORT	1	R	[160]	07h
Maximum enhanced area size	MAX_ENH_SIZE_MULT	3	R	[159:157]	0001CDh
Partitions attribute	PARTITIONS_ATTRIBUTE	1	R/W	[156]	00h
Partitioning setting	PARTITION_SETTING_COMPLETED	1	R/W	[155]	00h
General-purpose partition size	GP_SIZE_MULT_GP3	12	R/W	[154:152]	000000h
	GP_SIZE_MULT_GP2			[151:149]	000000h
	GP_SIZE_MULT_GP1			[148:146]	000000h
	GP_SIZE_MULT_GP0			[145:143]	000000h
Enhanced user data area size	ENH_SIZE_MULT	3	R/W	[142:140]	000000h
Enhanced user data start address	ENH_START_ADDR	4	R/W	[139:136]	00000000h
Reserved	–	1	–	[135]	–
Bad block management mode	SEC_BAD_BLK_MGMNT	1	R/W	[134]	00h
Reserved	–	1	–	[133]	–
Package case temperature is controlled	TCASE_SUPPORT	1	W/E_P	[132]	00h
Periodic wake-up	PERIODIC_WAKEUP	1	R/W/E	[131]	00h
Program CID/CSD in DDR mode support	PROGRAM_CID_CSD_DDR_SUPPORT	1	R	[130]	01h
Reserved	–	2	TBD	[129:128]	TBD
Vendor specific fields	VENDOR_SPECIFIC_FIELD	64	<vendor specific>	[127:64]	TBD
Native sector size	NATIVE_SECTOR_SIZE	1	R	[63]	00h
Sector size emulation	USE_NATIVE_SECTOR	1	R/W	[62]	00h
Sector size	DATA_SECTOR_SIZE	1	R	[61]	00h
1st initialization after disabling sector size emulation	INI_TIMEOUT_EMU	1	R	[60]	0Ah

Table 9: ECSD Register Field Parameters (Continued)

Name	Field	Size (Bytes)	Cell Type ¹	ECSD Bytes	ECSD Value
Class 6 commands control	CLASS_6_CTRL	1	R/W/E_P	[59]	00h
Number of addressed group to be re-released	DYNCAP_NEEDED	1	R	[58]	00h
Exception events control	EXCEPTION_EVENTS_CTRL	2	R/W/E_P	[57:56]	00h
Exception events status	EXCEPTION_EVENTS_STATUS	2	R	[55:54]	00h
Extended partitions attribute	EXT_PARTITIONS_ATTRIBUTE	2	R/W	[53:52]	00h
Context configuration	CONTEXT_CONF	15	R/W/E_P	[51:37]	00h
Packed command status	PACKED_COMMAND_STATUS	1	R	[36]	00h
Packed command failure index	PACKED_FAILURE_INDEX	1	R	[35]	00h
Power-off notification	POWER_OFF_NOTIFICATION	1	R/W/E_P	[34]	00h
Control to turn the Cache ON/OFF	CACHE_CTRL	1	R/W/E_P	[33]	00h
Flushing of the cache	FLUSH_CACHE	1	W/E_P	[32]	00h
Reserved	–	32	TBD	[31:0]	–

- Notes:
1. R = Read-only;
R/W = One-time programmable and readable;
R/W/E = Multiple writable with the value kept after a power cycle, assertion of the RST_n signal, and any CMD0 reset, and readable;
R/W/C_P = Writable after the value is cleared by a power cycle and assertion of the RST_n signal (the value not cleared by CMD0 reset) and readable;
R/W/E_P = Multiple writable with the value reset after a power cycle, assertion of the RST_n signal, and any CMD0 reset, and readable;
W/E_P = Multiple writable with the value reset after power cycle, assertion of the RST_n signal, and any CMD0 reset, and not readable
 2. Reserved bits should be read as 0.
 3. Micron has tested power failure under best-application knowledge conditions with positive results. Customers may request a dedicated test for their specific application condition. Micron set this register during factory test and used the one-time programming option.
 4. ^tH parameter in HS200 is 1.4ns. Refer to the JEDEC specification for the output timing diagram.



DC Electrical Specifications – Device Power

The device current consumption for various device configurations is defined in the power class fields of the ECSD register.

V_{CC} is used for the NAND Flash device and its interface voltage; V_{CCQ} is used for the controller and the e-MMC interface voltage.

Figure 6: Device Power Diagram

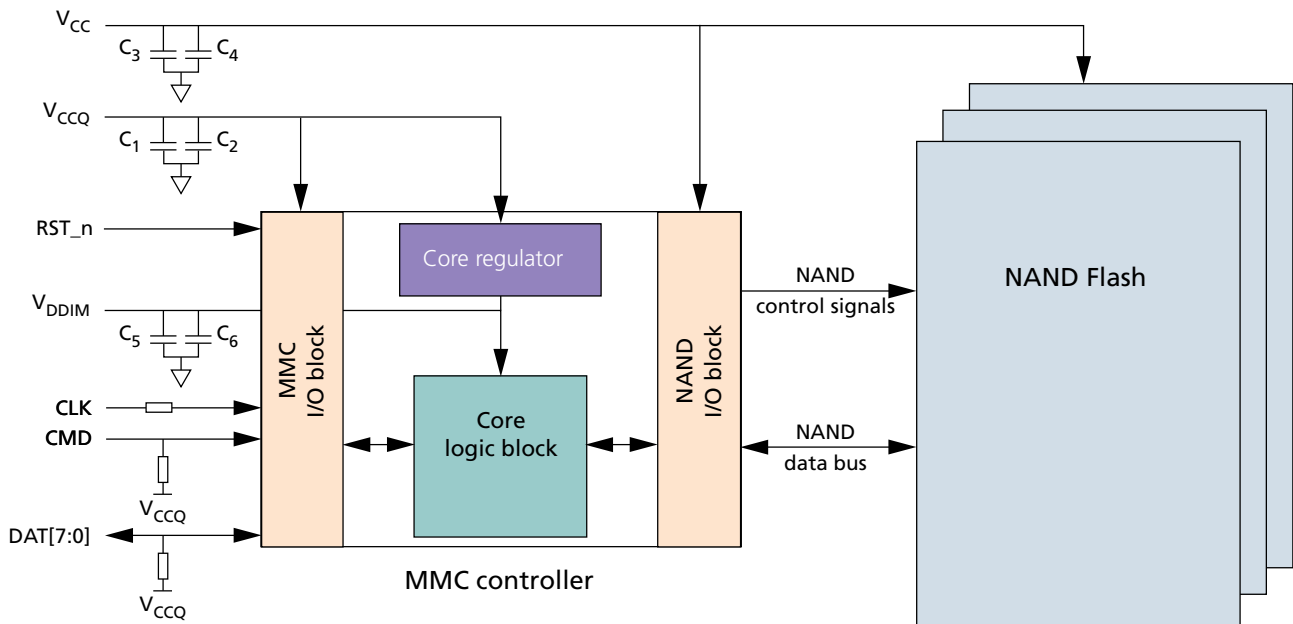

Table 10: Absolute Maximum Ratings

Parameters	Symbol	Min	Max	Unit
Voltage input	V_{IN}	-0.6	4.6	V
V_{CC} supply	V_{CC}	-0.6	4.6	V
V_{CCQ} supply	V_{CCQ}	-0.6	4.6	V

Table 11: Power Domains

Parameter	Symbol	Comments
Host interface	V_{CCQM}	High voltage range = 3.3V (nominal) Low voltage range = 1.8V (nominal)
Memory	V_{CCM}	High voltage range = 3.3V (nominal)
Internal	V_{DDIM}	The internal regulator connection to an external decoupling capacitor

Table 12: Capacitor and Resistance Specifications

Parameter	Symbol	Min	Max	Typ	Units	Notes
Pull-up resistance: CMD	R_CMD	4.7	50	10	kΩ	1
Pull-up resistance: DAT[7:0]	R_DAT	10	50	50	kΩ	1
Pull-up resistance: RST_n	R_RST_n	4.7	50	50	kΩ	2
CLK/CMD/DAT[7:0] impedance		45	55	50	Ω	3
Serial resistance on CLK	SR_CLK	0	47	22	Ω	
V _{CCQ} capacitor	C1	2.2	4.7	2.2	μF	4
	C2	0.1	0.22	0.1		
V _{CC} capacitor (≤8GB)	C3	2.2	4.7	2.2	μF	5
	C4	0.1	0.22	0.1		
V _{CC} capacitor (>8GB)	C3	2.2	4.7	4.7	μF	5
	C4	0.1	0.22	0.22		
V _{DDIM} capacitor (C _{reg})	C5	1	4.7	1	μF	6
	C6	0.1	0.1	0.1		

- Notes:
- Used to prevent bus floating.
 - If host does not use H/W RESET (RST_n), pull-up resistance is not needed on RST_n line (Extended_CSD[162] = 00h).
 - Impedance match.
 - The coupling capacitor should be connected with V_{CCQ} and V_{SSQ} as closely as possible.
 - The coupling capacitor should be connected with V_{CC} and V_{SS} as closely as possible.
 - The coupling capacitor should be connected with V_{DDIM} and V_{SS} as closely as possible.



Revision History

Rev. E – 06/14

- Changed "WFBGA" to "VFBGA" in the Features section
- Changed the package dimensions diagram to VFBGA

Rev. D – 05/14

- Updated the operating temperature range and ⁴IH spec

Rev. C – 04/14

- Added the "Absolute Maximum Ratings" table to the DC Electrical Specifications section

Rev. B – 02/14

- Removed "Preliminary" from the document and promoted to "Production" status

Rev. A – 10/13

- Initial release

8000 S. Federal Way, P.O. Box 6, Boise, ID 83707-0006, Tel: 208-368-3900
www.micron.com/productsupport Customer Comment Line: 800-932-4992
Micron and the Micron logo are trademarks of Micron Technology, Inc.
All other trademarks are the property of their respective owners.

This data sheet contains minimum and maximum limits specified over the power supply and temperature range set forth herein. Although considered final, these specifications are subject to change, as further product development and data characterization sometimes occur.

X-ON Electronics

Largest Supplier of Electrical and Electronic Components

Click to view similar products for [Flash Memory](#) category:

Click to view products by [Micron](#) manufacturer:

Other Similar products are found below :

[MBM29F200TC-70PFTN-SFLE1](#) [MBM29F400BC-70PFTN-SFLE1](#) [MBM29F800BA-90PF-SFLE1](#) [8 611 200 906 9990933135](#)
[AM29F200BB-90DPI 1](#) [AT25DF021A-MHN-Y](#) [AT25DF256-SSHN-T](#) [EAN62691701](#) [N25Q512A83G1240F](#) [P520366230636](#) [8 905 959](#)
[076T](#) [8 905 959 252](#) [8 925 850 296](#) [260332-002 04](#) [S29AL008J55BFIR20](#) [S29AL008J55TFIR23](#) [S29AL008J70BFI010](#)
[S29AL008J70BFI013](#) [S29AL032D90TFA040](#) [S29AS016J70BHIF40](#) [S29GL064N90TFI013](#) [S29PL064J55BFI120](#) [S76MSA90222AHD000](#)
[S99AL016D0019](#) [9990932415](#) [A2C53026990](#) [SST39VF400A-70-4I-MAQE](#) [AM29F400BB-55SF0](#) [AM29F400BB-55SI](#) [MBM29F400BC-](#)
[90PFVGTSFLE1](#) [MBM29F800BA-70PFTN-SFLE1](#) [MBM29F800TA-90PFCN-SFLE1](#) [AT25DF011-MAHN-T](#) [AT25DN011-MAHF-T](#)
[AT45DQ161-SHFHB-T](#) [RP-SDCCTH0](#) [S29AL016J70TFN013](#) [S29CD016J0MQFM110](#) [S29GL032N90BFI042](#) [S29GL032N90FAI033](#)
[S29GL064N90TFI023](#) [S29GL128S10GHIV20](#) [S29PL127J70BAI020](#) [S34ML01G200GHI000](#) [S34ML02G200TFI003](#) [S34MS02G200BHI000](#)
[S34MS02G200TFI000](#) [S71VS256RC0AHK4L0](#) [AT25SF041-MHD-T](#)