

Small Package, High Performance, Asynchronous Boost For 10 WLED Driver ME2212

General Description:

The **ME2212** is a high frequency, asynchronous boost converter. The internal MOSFET can support up to 10 White LEDs for backlighting and OLED power application, and the internal soft start function can reduce the inrush current. The device operates with 1-MHz fixed switching frequency to allow small external components and to simplify possible EMI problems. Moreover, the IC comes with 46V over voltage protection to allow inexpensive and small-output capacitors with lower voltage ratings. The LED current is initially set with the external sense resistor R_s .

Features:

- VIN Operating Range : 2.5V to 5.5V
- Internal Power N-MOSFET Switch
- Wide Range for PWM Dimming (100Hz to 200kHz)
- 1MHz Switching Frequency
- Minimize the External Component Counts
- Internal Soft Start
- Internal Compensation
- Under Voltage Protection
- Over Voltage Protection
- Over Temperature Protection

Applications:

- Cellular Phones
- Digital still cameras
- PDAs and Smart Phones and MP3 and OLED.
- Probable Instruments

R_s Resistor Value Selection:

TYP. (Ω)	I_{LED} (mA)
10	20

Typical Application:

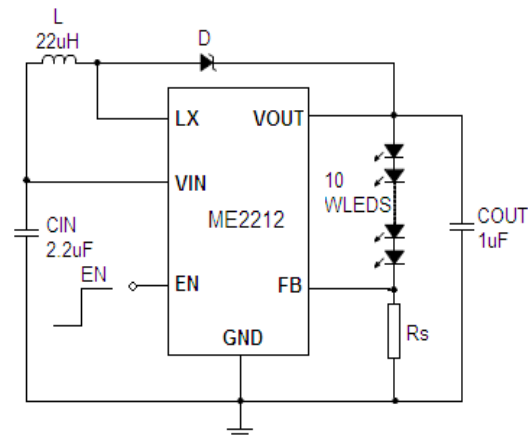

$$I_{LED} = 20\text{mA}, \quad R_s = 10\Omega$$

Selection Guide:

Pin Configuration & Marking Information:

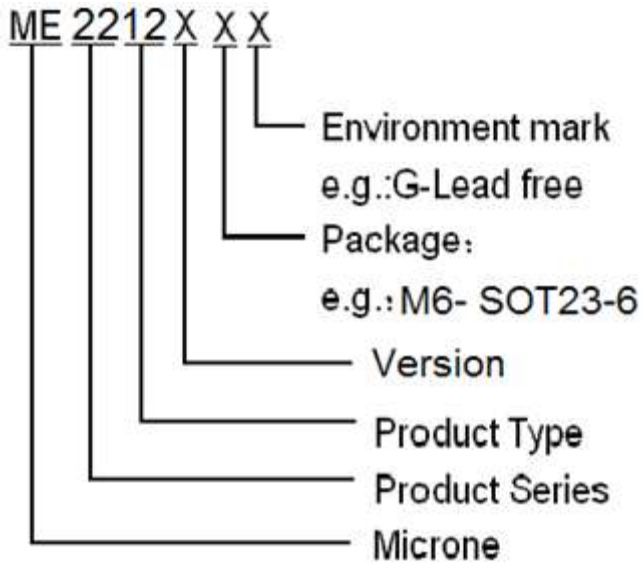

Pin information:

Pin Number	Name	Function
1	LX	Switch
2	GND	Ground
3	FB	Feedback
4	EN	Chip Enable
5	VOUT	Output
6	VIN	Input

Absolute Maximum Ratings:

Parameter	Symbol	Ratings	Units
Input Voltage	V_{IN}	-0.3V~6V	V
LX Pin Voltage	LX	-0.3V~6V	V
FB Pin Voltage	FB	-0.3V~6V	V
Operating Temperature Range	T_{OPR}	-40°C~85°C	°C
Storage Temperature Range	T_{STG}	-65°C~125°C	°C
Lead Temperature (Soldering, 10 sec)	T_L	260°C	°C
Internal Power Dissipation (SOT23-6)	P_D	400	mW

Function Block Diagram:

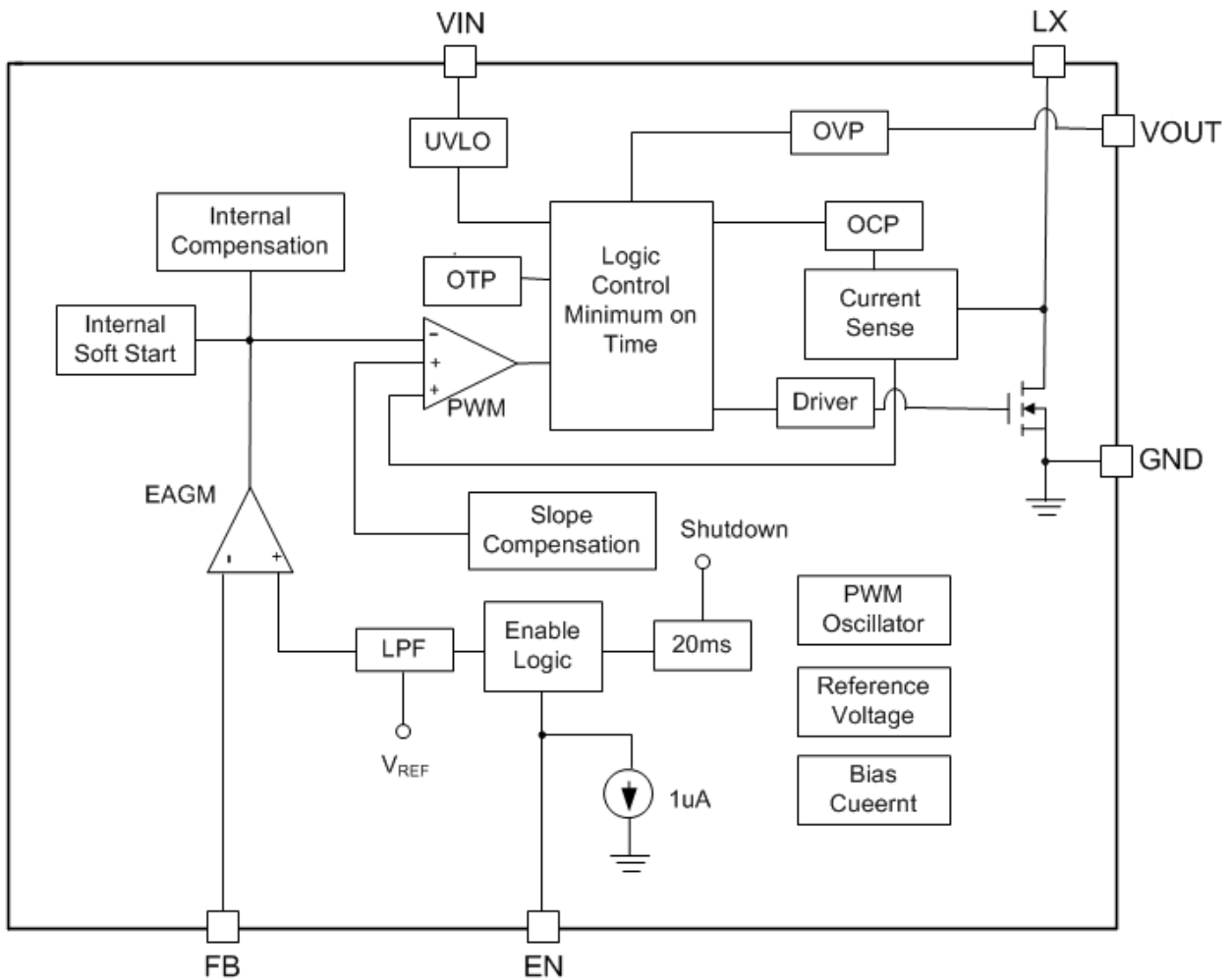

Electrical Characteristic

T=25°C, $V_{IN}=V_{EN}=3.7V$, L=22uH, $C_{in}=2.2\ \mu F$, $C_{out}=1\ \mu F$, unless otherwise noted.

Parameter	Symbol	Condition	Min	Typ	Max	Unit
Input Voltage Range	V_{IN}		2.5	3.7	5.5	V
Under Voltage Lock Out	V_{UVLO}		2	2.2	2.45	V
UVLO Hystersis				0.1		V
Supply Current	ISS	No external Component		0.8	1.5	mA
Shutdown Current	I_{SHDN}	No external Component $V_{EN}=0V$	1	3	5	uA
Oscillator Frequency	F_{OSC}		0.85	1.1	1.5	MHz
Maximum Duty Cycle			90	92		%
Feedback Voltage	V_{FB}		190	200	210	mV
On Resistance	$R_{DS(ON)}$			0.7	1.2	Ω
EN Threshold	Logic-High Voltage	V_{IH}	1.6			V
	Logic-Low Voltage	V_{IL}			0.9	V
Over-Voltage Threshold	V_{OCP}		42	46	50	V
Over-Current Threshold	I_{OCP}		1	1.2		A
Efficiency	η	$I_{LED}=20mA$		85		%
Over Temperature Shutdown	OTS			150		°C

Typical Operating Characteristics

1. Efficiency vs. Output Current (3 White LEDs)

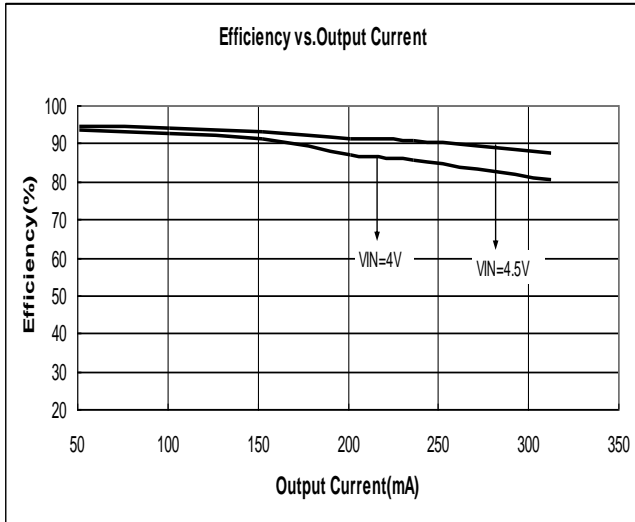

2. Efficiency vs. Input Voltage (10 White LEDs)

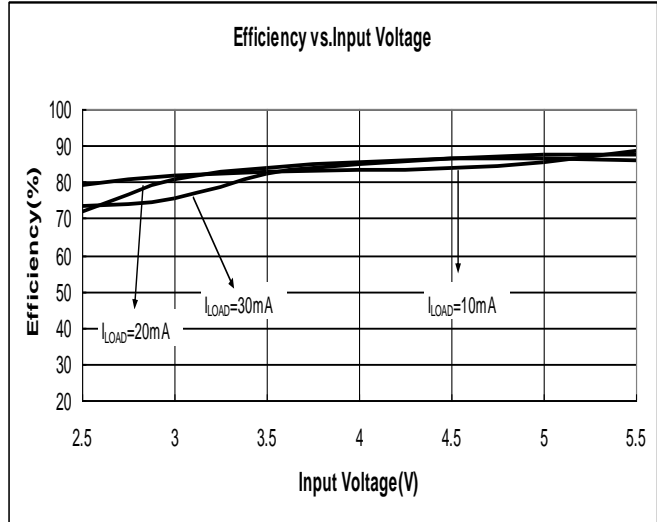

3. Frequency vs. Input Voltage (I_LED=20mA)

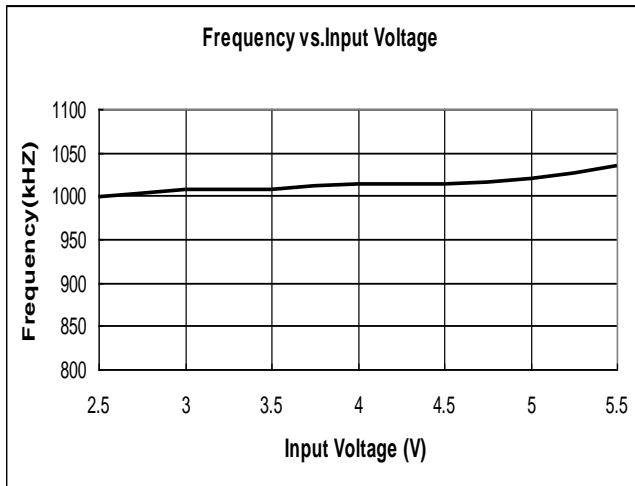

4. Frequency vs. Temperature (V_IN=3.7V, I_LED=20mA)

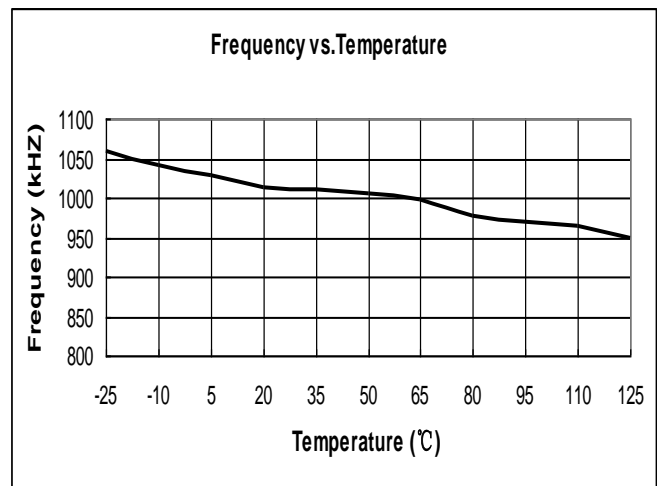

5. V_{FB} vs. Input Voltage
(10 White LEDs, $I_{LED}=20mA$)

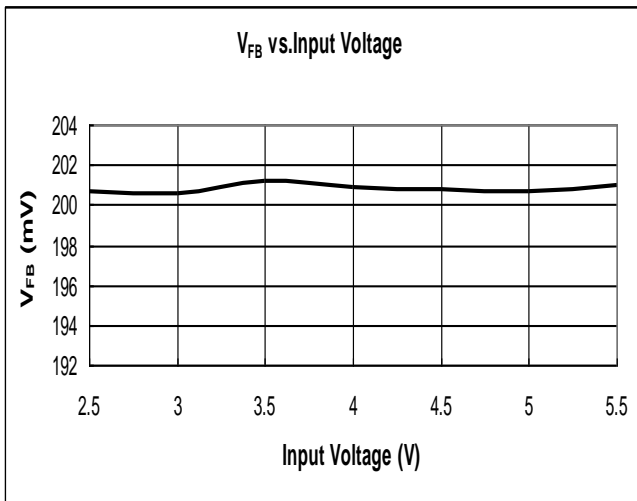

6. V_{FB} vs. Temperature
($I_{LED}=20mA$)

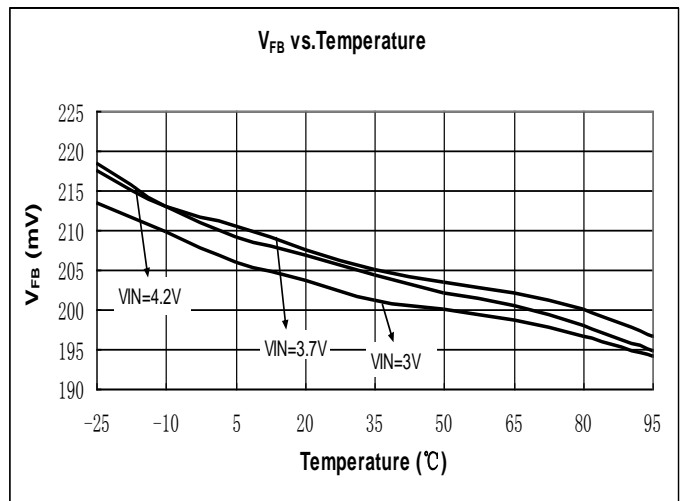

7. V_{FB} vs. Output Current
(10 White LEDs)

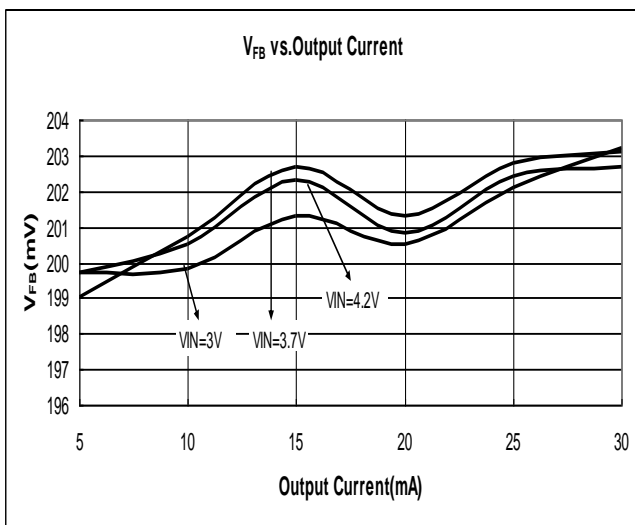

8. Enable Voltage vs. Input Voltage
(10 White LEDs)

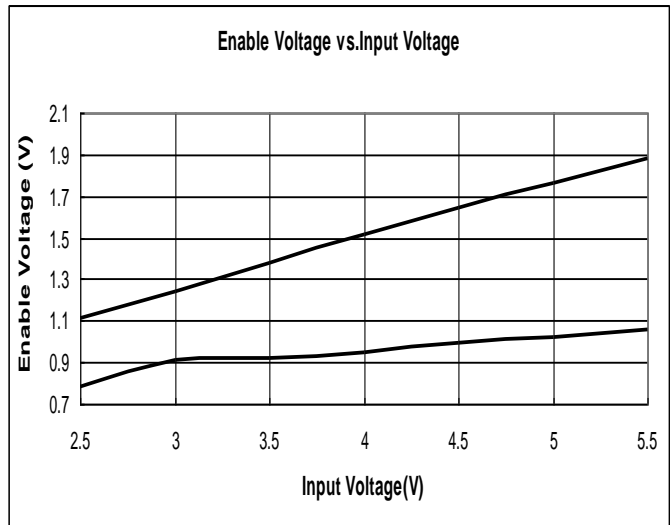

Package Information

• SOT-23-6

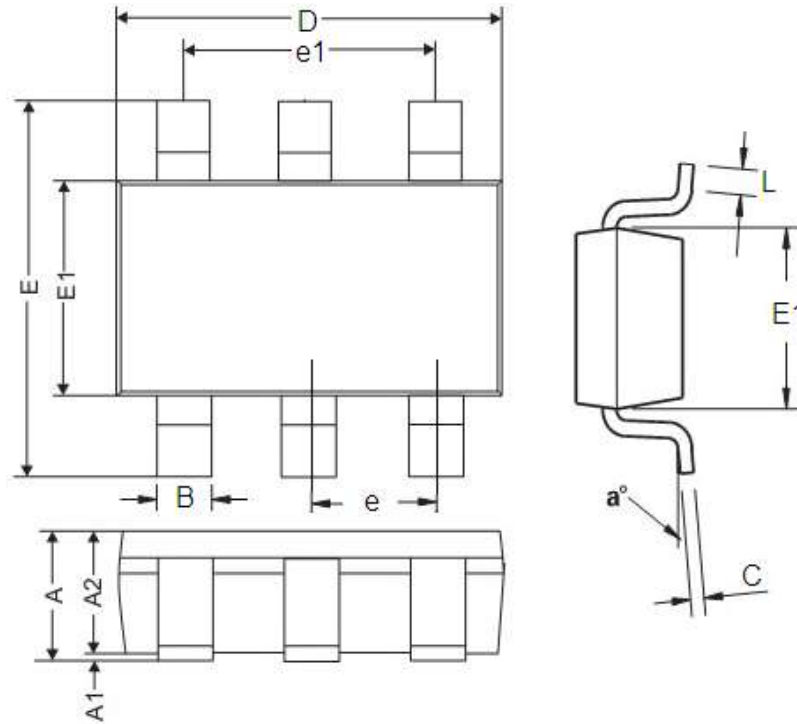

DIM	Millimeters		Inches	
	Min	Max	Min	Max
A	0.9	1.45	0.0354	0.0570
A1	0	0.15	0	0.0059
A2	0.9	1.3	0.0354	0.0511
B	0.2	0.5	0.0078	0.0196
C	0.09	0.26	0.0035	0.0102
D	2.7	3.10	0.1062	0.1220
E	2.2	3.2	0.0866	0.1181
E1	1.30	1.80	0.0511	0.0708
e	0.95REF		0.0374REF	
e1	1.90REF		0.0748REF	
L	0.10	0.60	0.0039	0.0236
a°	0°	30°	0°	30°

- The information described herein is subject to change without notice.
- Nanjing Micro One Electronics Inc is not responsible for any problems caused by circuits or diagrams described herein whose related industrial properties, patents, or other rights belong to third parties. The application circuit examples explain typical applications of the products, and do not guarantee the success of any specific mass-production design.
- Use of the information described herein for other purposes and/or reproduction or copying without the express permission of Nanjing Micro One Electronics Inc is strictly prohibited.
- The products described herein cannot be used as part of any device or equipment affecting the human body, such as exercise equipment, medical equipment, security systems, gas equipment, or any apparatus installed in airplanes and other vehicles, without prior written permission of Nanjing Micro One Electronics Inc.
- Although Nanjing Micro One Electronics Inc exerts the greatest possible effort to ensure high quality and reliability, the failure or malfunction of semiconductor products may occur. The user of these products should therefore give thorough consideration to safety design, including redundancy, fire-prevention measures, and malfunction prevention, to prevent any accidents, fires, or community damage that may ensue.

X-ON Electronics

Largest Supplier of Electrical and Electronic Components

Click to view similar products for [LED Display Drivers](#) category:

Click to view products by [Micro One](#) manufacturer:

Other Similar products are found below :

[STP16CPP05XTTR](#) [SCT2027CSSG](#) [KP22306WGA](#) [KP1199AWPA](#) [KP1199BWPA](#) [WS9088AS7P](#) [GN1628T](#) [BCT3236EGH-TR](#)
[HT1628BRWZ](#) [KP1192SPA](#) [KP1182SPA](#) [KP1262FSPA](#) [KP1072LSPA](#) [KP1191SPA](#) [KP18001WPA](#) [KP1070LSPA](#) [KP1221SPA](#)
[KP107ALSPA](#) [GN1640T](#) [MBI5253GP-A](#) [MBI5124GM-B](#) [WS90561T S7P](#) [WS9821B S7P](#) [WS9032GS7P](#) [LYT3315D](#) [M08888G-11](#)
[M08890G-13](#) [SCT2001ASIG](#) [SCT2024CSOG](#) [SCT2024CSSG](#) [AL8400QSE-7](#) [PR4401](#) [PR4403](#) [PCA9685PW](#) [STP16CPC05XTTR](#)
[WS2821B](#) [PR4402](#) [M08898G-13](#) [RT8471GJ5](#) [RT9284A-20GJ6E](#) [TLC59482DBQR](#) [ISL97634IRT14Z-TK](#) [AW36413CSR](#) [LP5562TMX](#)
[WS2818B](#) [BCR401R](#) [BCR401U](#) [BCR402U](#) [SCT2004CSOG](#) [SCT2026CSOG](#)