



Ultra-small package High-precision Voltage Detector with delay circuit, ME2805 Series

General Description

ME2805 Series is a series of high-precision voltage detectors with a built-in delay time generator of fixed time developed using CMOS process. Internal oscillator and counter timer can delay the release signal without external parts. Detect voltage is extremely accurate with minimal temperature drift. CMOS output configurations are available.

Features

- Highly accuracy: $\pm 1\%$
- Low power consumption: TYP 0.9 μ A ($V_{DD}=3V$)
- Detect voltage range : 1.0V~6.5V in 0.1V increments
- Operating voltage range: 0.7V~7V
- Detect voltage temperature characteristics: TYP ± 100 ppm/ $^{\circ}C$
- Output configuration: CMOS

Typical Application

- Power monitor for portable equipment such as notebook computers, digital still cameras, PDA, and cellular phones
- Constant voltage power monitor for cameras, video equipment and communication devices.
- Power monitor for microcomputers and reset for CPUs.
- System battery life and charge voltage monitors

Package

- 3-pin SOT23-3、SOT23

Typical Application Circuit

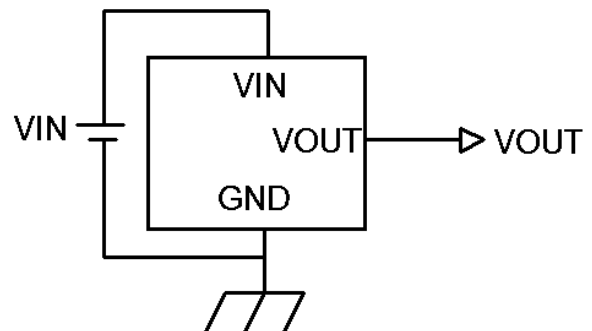

Selection Guide

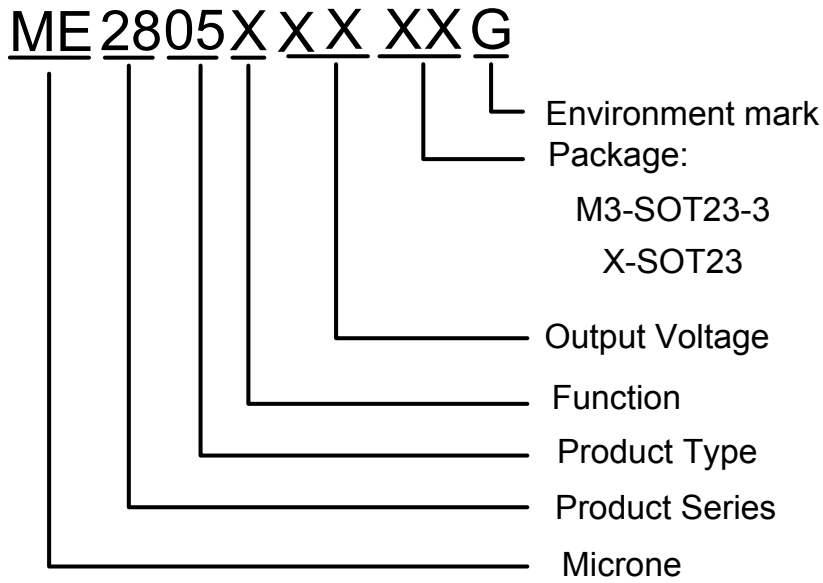

| product series | product description |
|----------------|--|
| ME2805A263M3G | V _{OUT} =2.63V; Rising edge detection; Package: SOT23-3 |
| ME2805A263XG | V _{OUT} =2.63V; Rising edge detection; Package: SOT23 |
| ME2805A293M3G | V _{OUT} =2.93V; Rising edge detection; Package: SOT23-3 |
| ME2805A293XG | V _{OUT} =2.93V; Rising edge detection; Package: SOT23 |
| ME2805A308XG | V _{OUT} =3.08V; Rising edge detection; Package: SOT23 |
| ME2805A463XG | V _{OUT} =4.63V; Rising edge detection; Package: SOT23 |

NOTE: If you need other voltage and package, please contact our sales staff.

Pin Configuration

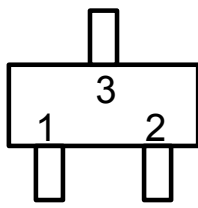

SOT-23

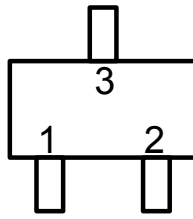

SOT-23-3

Pin Assignment

| PIN Number | Pin Name | Function |
|-----------------|----------|----------------|
| SOT-23-3/SOT-23 | | |
| 1 | VSS | Ground |
| 2 | VOUT | Output Voltage |
| 3 | VDD | Input Voltage |

Block Diagram

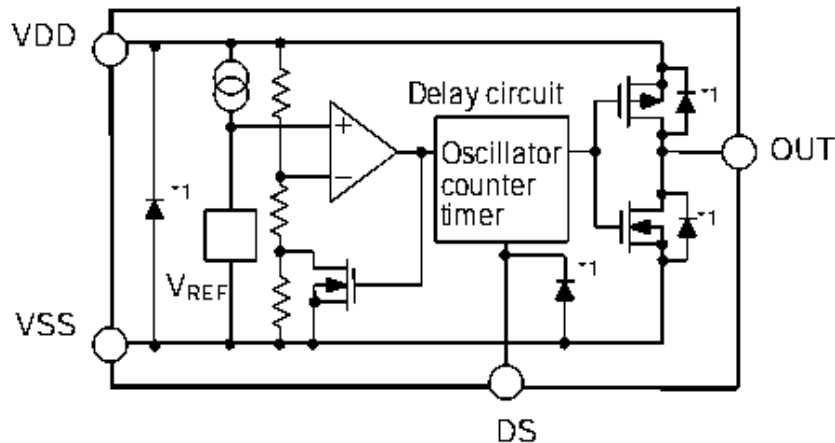

*1. Parasitic diode

Absolute Maximum Ratings

| PARAMETER | SYMBOL | RATINGS | UNITS |
|------------------------------------|--------------|------------|-----------------------|
| V_{IN} Input Voltage | V_{IN} | 8 | V |
| Output Current | I_{OUT} | 50 | mA |
| Output Voltage | CMOS | V_{OUT} | GND-0.3~ $V_{IN}+0.3$ |
| Continuous Total Power Dissipation | SOT-23-3 | P_d | 300 |
| | SOT-23 | | 250 |
| Operating Ambient Temperature | T_{Opr} | -40~+85 | °C |
| Storage Temperature | T_{stg} | -40~+125 | °C |
| Soldering temperature and time | T_{solder} | 260°C, 10s | |
| ESD | MM | 400 | V |
| | HBM | 4000 | V |

Electrical Characteristics

($-V_{DET}(S)=1.0V$ to $6.5V\pm 2\%$, $T_a=25^\circ C$, unless otherwise noted)

| Parameter | Symbol | Conditions | Min. | Typ | Max. | Units | Test circuit |
|---------------------------------|--|--|---------------------------|---------------|---------------------------|-----------------|--------------|
| Detect Voltage (Output Voltage) | $-V_{DET}$ | - | $-V_{DET}(S) \times 0.99$ | $-V_{DET}(S)$ | $-V_{DET}(S) \times 1.01$ | V | 1 |
| Hysteresis Range | V_{HYS} | - | 0.03 | 0.06 | 0.1 | V | |
| Supply Current | ISS | VDD=3V (below 2.5V) | - | 0.9 | 1.5 | uA | 2 |
| | | VDD=5V (2.5V-4.5V) | - | 1.4 | 2.8 | | |
| | | VDD=7V (4.5V-6.5V) | - | 1.8 | 3.6 | | |
| Output Current | Iout N-ch | VDS=0.5V VDD=0.7V | 0.01 | 0.19 | -- | mA | 3 |
| | Iout P-ch | VDS=0.5V VDD=7V | 1.7 | 3.4 | -- | mA | 4 |
| Operating voltage | VDD | - | 0.7 | - | 7 | V | 1 |
| Delay time | Td1 | VDD=-VDET+1V DS low | 130 | 200 | 290 | ms | 1 |
| | Td2 | VDD=-VDET+1V DS high | 110 | 220 | 330 | us | 5 |
| Temperature characteristics | $\frac{\Delta - V_{DET}}{\Delta T_a \bullet -V_{DET}}$ | $\Delta T_a = -40^\circ C \sim 85^\circ C$ | - | ± 100 | ± 350 | ppm/ $^\circ C$ | 1 |

- Note: 1、 $-V_{DET}(S)$: Specified Detection Voltage value
 2、 $-V_{DET}$: Actual Detection Voltage value
 3、Release Voltage: $+V_{DET}=-V_{DET}+V_{HYS}$

Test Circuits:

1.

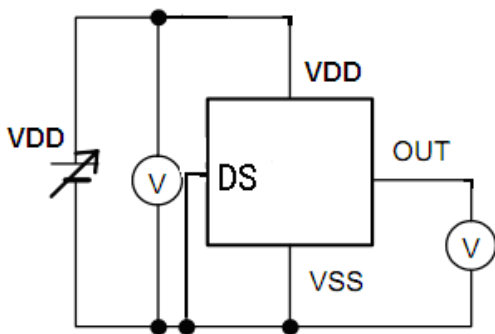

2.

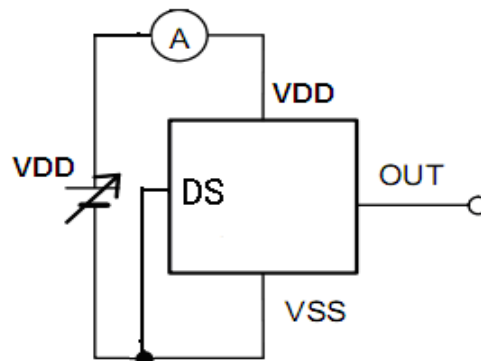

3.

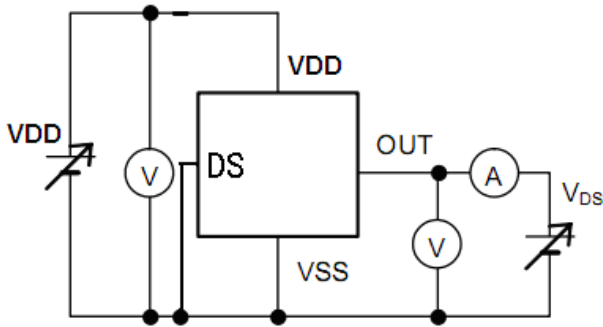

4.

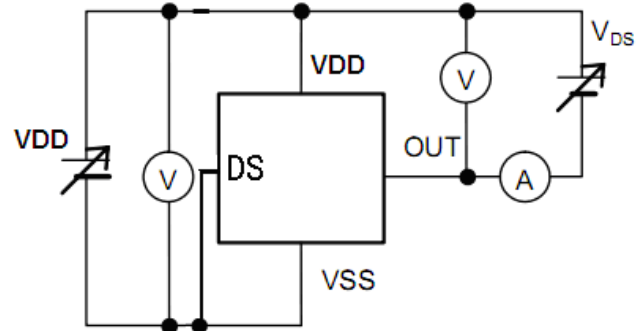

5.

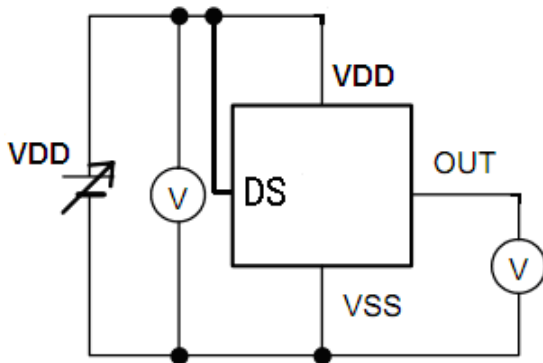

Functional Description:

1. Basic Operation: CMOS Output (Active Low)

1-1. When the power supply voltage (VDD) is higher than the release voltage (+VDET), the Nch transistor is OFF and the Pch transistor is ON to provide VDD (high) at the output. Since the Nch transistor N1 in Figure 1 is OFF, the

comparator input voltage is $\frac{(R_B + R_C) \cdot VDD}{R_A + R_B + R_C}$.

1-2. When the VDD goes below +VDET, the output provides the VDD level, as long as VDD remains above the detection voltage (-VDET). When the VDD falls below -VDET (point A in Figure 2), the Nch transistor becomes ON, the Pch transistor becomes OFF, and the VSS level appears at the output. At this time the Nch

transistor N1 in Figure 1 becomes ON, the comparator input voltage is changed to $\frac{R_B \cdot VDD}{R_A + R_B}$.

1-3. When the VDD falls below the minimum operating voltage, the output becomes undefined, or goes to VDD when the output is pulled up to VDD.

1-4. The VSS level appears when VDD rises above the minimum operating voltage. The VSS level still appears even when VDD surpasses the -VDET, as long as it does not exceed the release voltage +VDET.

1-5. When VDD rises above +VDET (point B in Figure 2), the Nch transistor becomes OFF and the Pch transistor becomes ON to provide VDD at the output. The VDD at the OUT pin is delayed for Td due to the delay circuit.

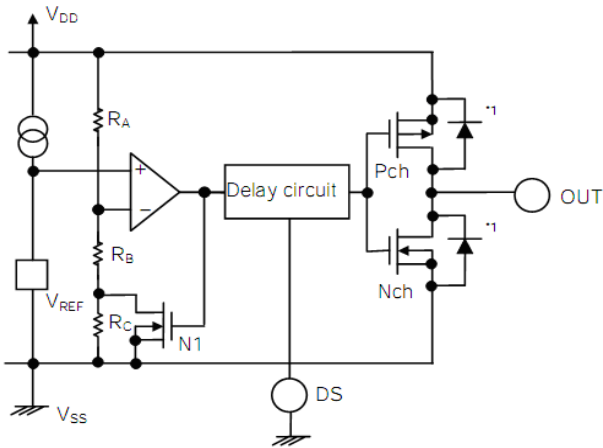

*1. Paracitic diode

Figure 1 Operation 1

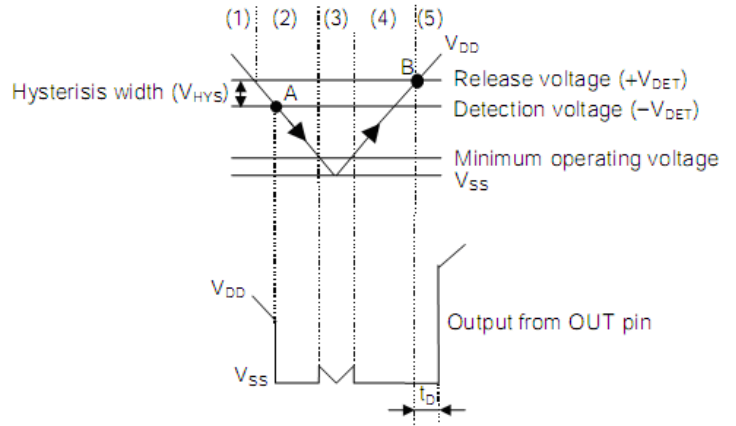

Figure 2 Operation 2

2. Delay Circuit

2-1. Delay Time

The delay circuit delays the output signal from the time at which the power voltage (V_{DD}) exceeds the release voltage ($+V_{DET}$) when V_{DD} is turned on. The output signal is not delayed when the V_{DD} goes below the detection voltage ($-V_{DET}$). (Refer to Figure 2.) The delay time (t_D) is a fixed value that is determined by a built-in oscillation circuit and counter.

2-2. DS Pin (ON/OFF Switch Pin for Delay Time)

The DS pin should be connected to Low or High. When the DS pin is High, the output delay time becomes short since the output signal is taken from the middle of counter circuit (Refer to Figure 3).

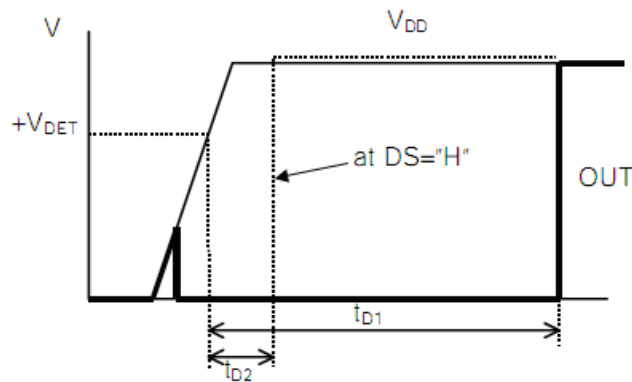

Figure 3

Directions for use:

- 1、 Please use this IC within the stated maximum ratings. Operation beyond these limits may cause degrading or permanent damage to the device.
- 2、 When a resistor is connected between the V_{DD} pin and the input with CMOS output configurations, oscillation may occur as a result of voltage drops at R_{IN} if load current(I_{OUT}) exists.(refer to the Oscillation Description(1) below)
- 3、 When a resistor is connected between the V_{DD} pin and the input with CMOS output configurations, oscillation may occur as a result of through current at the time of voltage release even if load current(I_{OUT}) does not exist. (refer to the Oscillation Description(2) below)
- 4、 With a resistor connected between the V_{DD} and the input, detect and release voltage will rise as a result of the IC's supply current flowing through the V_{DD} pin.
- 5、 In order to stabilize the IC's operations, please ensure that V_{DD} pin's input frequency's rise and fall times are more than several μ Sec/V.

Oscillation Description:

- 1、 Output current oscillation with the CMOS output configuration

When the voltage applied at IN rises, release operations commence and the detector's output voltage increase. Load current(I_{OUT}) will flow at R_L . Because a voltage drop($R_{IN} * I_{OUT}$) is produced at the R_{IN} resistor, located between the input(IN) and the V_{DD} pin. The load current will flow via the IC's pin. The voltage drop will also lead to a fall in the voltage level at the V_{DD} pin. When the V_{DD} pin voltage level falls below the detect voltage level, detect operations will commence. Following detect operations, load current flow will cease and since voltage drop at R_{IN} will disappear, the voltage level at the V_{DD} pin will rise and release operations will begin over again. Oscillation may occur with this "release-detect-release" repetition. Further, this condition will also appear via means of a similar mechanism during detect operations.

- 2、 Oscillation as a result of through current

Since the ME2805 series are CMOS IC's, through current will flow when the IC's internal circuit switching operates(during release and detect operations). Consequently, oscillation is liable to occur as a result of drops in voltage at the through current's resistor(R_{IN}) during release voltage operations.(refer to diagram 2) since hysteresis exists during detect operations, oscillation is unlikely to occur.

Type Characteristics

1、 SUPPLY CURRENT VS. AMBIENT TEMPERATURE

VDD=5V,-VDET=2.63V

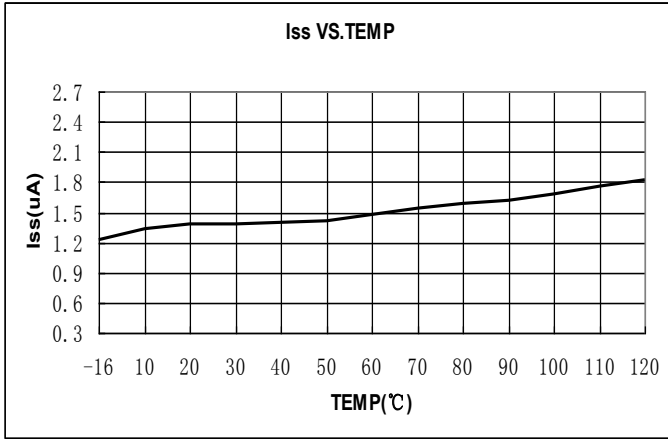

VDD=2.5V,-VDET=2.63V

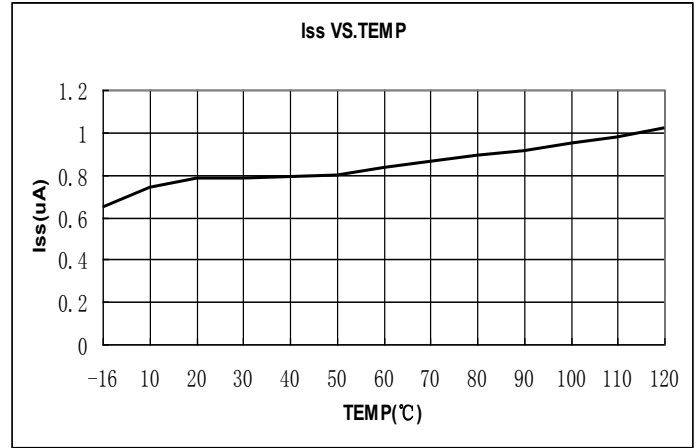

2、 SUPPLY CURRENT VS. INPUT VOLTAGE

-VDET=2.63V (T=25°C)

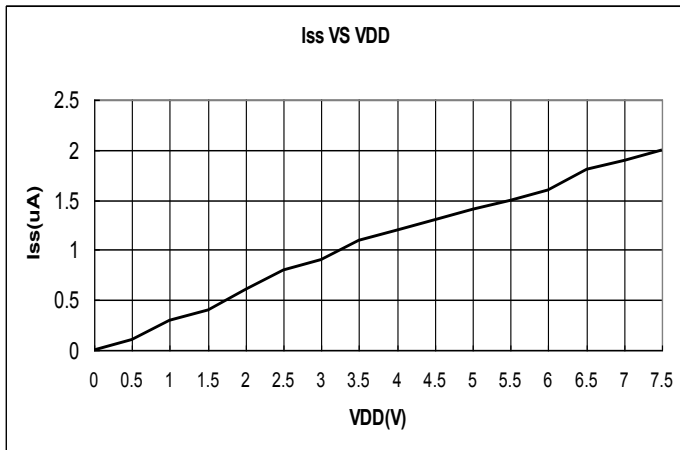

3、 DETECT,RELEASE VOLTAGE VS. AMBIENT TEMPERATURE

-VDET=2.63V

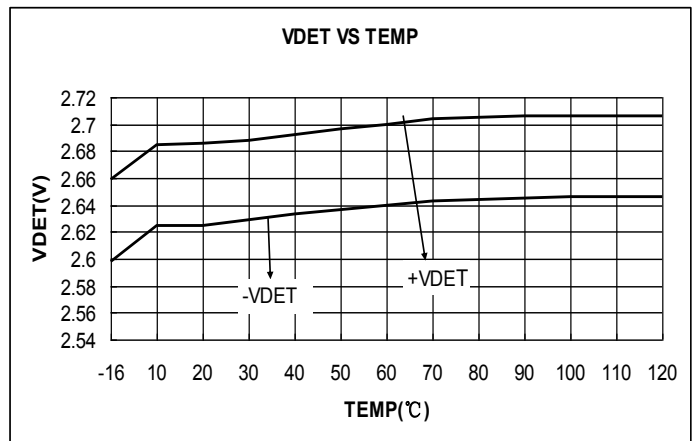

4、 OUTPUT CURRENT VS. INPUT VOLTAGE

N-ch VDS=0.5V,-VDET=2.63V

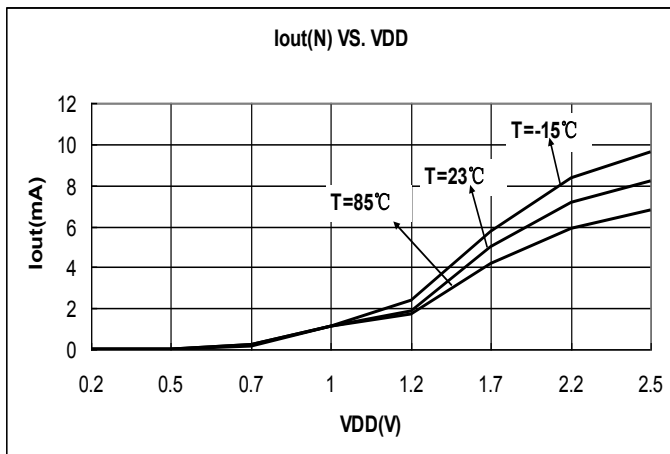

P-ch VDS=0.5V,-VDET=2.63V

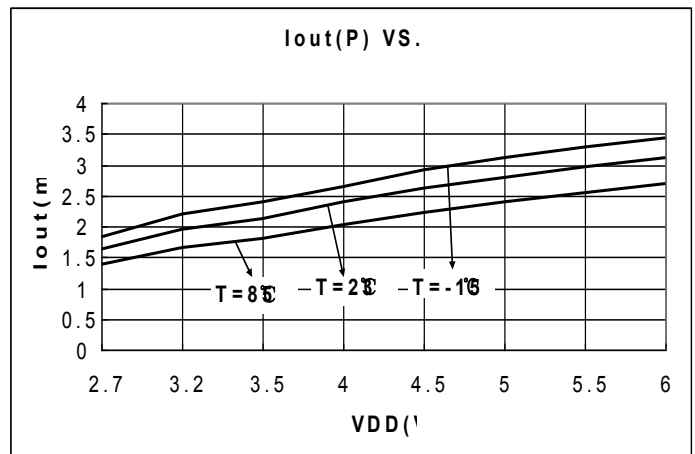

Packaging Information

● SOT23

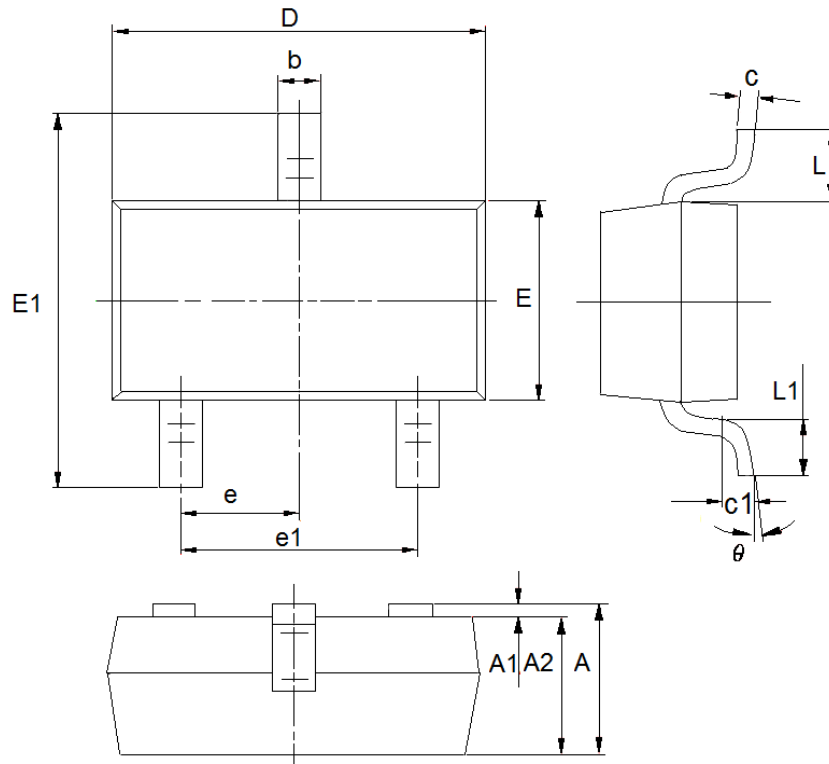

| DIM | Millimeters | | Inches | |
|-------|-------------|------|-------------|--------|
| | Min | Max | Min | Max |
| A | 0.9 | 1.2 | 0.0354 | 0.0472 |
| A1 | 0 | 0.14 | 0.0000 | 0.0055 |
| A2 | 0.9 | 1.05 | 0.0354 | 0.0413 |
| b | 0.28 | 0.52 | 0.0110 | 0.0205 |
| c | 0.07 | 0.23 | 0.0028 | 0.0091 |
| D | 2.8 | 3.0 | 0.1102 | 0.1181 |
| e1 | 1.8 | 2.0 | 0.0709 | 0.0787 |
| E | 1.2 | 1.4 | 0.0472 | 0.0551 |
| E1 | 2.2 | 2.6 | 0.0866 | 0.1024 |
| e | 0.95(TYP) | | 0.0374(TYP) | |
| L | 0.55(TYP) | | 0.0217(TYP) | |
| L1 | 0.25 | 0.55 | 0.0098 | 0.0217 |
| theta | 0 | 8° | 0.0000 | 8° |
| c1 | 0.25(TYP) | | 0.0098(TYP) | |

● SOT23-3

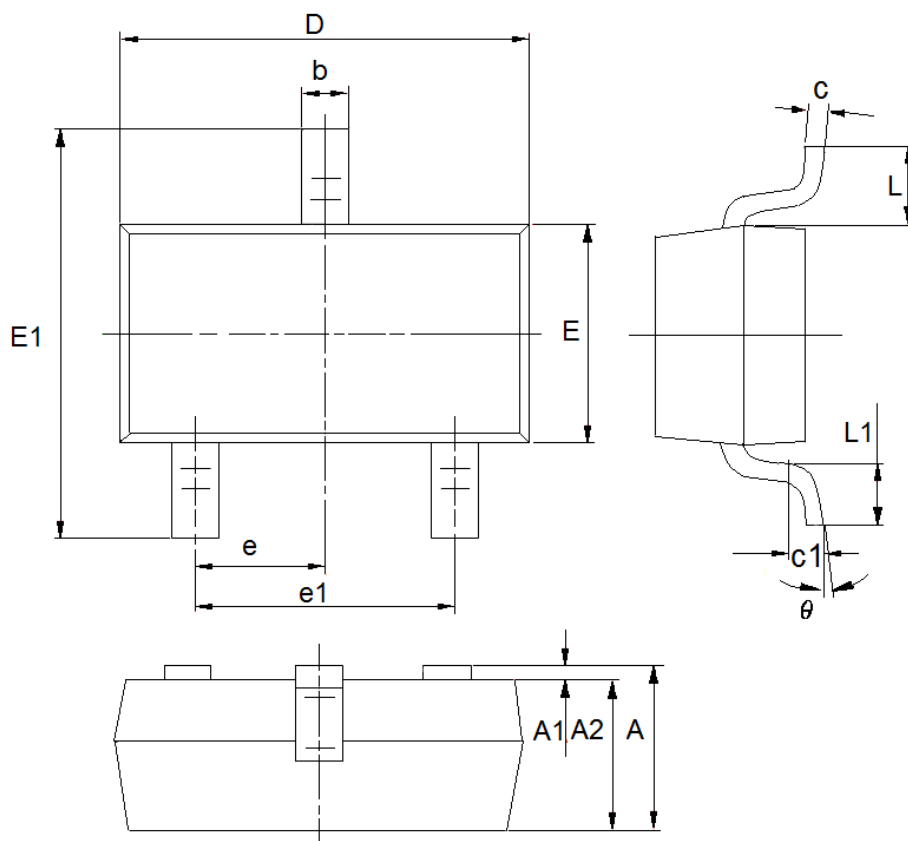

| DIM | Millimeters | | Inches | |
|----------|-------------|------|-------------|--------|
| | Min | Max | Min | Max |
| A | 0.9 | 1.2 | 0.0354 | 0.0472 |
| A1 | 0 | 0.14 | 0.0000 | 0.0055 |
| A2 | 0.9 | 1.05 | 0.0354 | 0.0413 |
| b | 0.28 | 0.52 | 0.0110 | 0.0205 |
| c | 0.07 | 0.23 | 0.0028 | 0.0091 |
| D | 2.8 | 3.0 | 0.1102 | 0.1181 |
| e1 | 1.8 | 2.0 | 0.0709 | 0.0787 |
| E | 1.2 | 1.4 | 0.0472 | 0.0551 |
| E1 | 2.2 | 2.6 | 0.0866 | 0.1024 |
| e | 0.95(TYP) | | 0.0374(TYP) | |
| L | 0.55(TYP) | | 0.0217(TYP) | |
| L1 | 0.25 | 0.55 | 0.0098 | 0.0217 |
| θ | 0 | 8° | 0.0000 | 8° |
| c1 | 0.25(TYP) | | 0.0098(TYP) | |

- The information described herein is subject to change without notice.
- Nanjing Micro One Electronics Inc is not responsible for any problems caused by circuits or diagrams described herein whose related industrial properties, patents, or other rights belong to third parties. The application circuit examples explain typical applications of the products, and do not guarantee the success of any specific mass-production design.
- Use of the information described herein for other purposes and/or reproduction or copying without the express permission of Nanjing Micro One Electronics Inc is strictly prohibited.
- The products described herein cannot be used as part of any device or equipment affecting the human body, such as exercise equipment, medical equipment, security systems, gas equipment, or any apparatus installed in airplanes and other vehicles, without prior written permission of Nanjing Micro One Electronics Inc.
- Although Nanjing Micro One Electronics Inc exerts the greatest possible effort to ensure high quality and reliability, the failure or malfunction of semiconductor products may occur. The user of these products should therefore give thorough consideration to safety design, including redundancy, fire-prevention measures, and malfunction prevention, to prevent any accidents, fires, or community damage that may ensue.

X-ON Electronics

Largest Supplier of Electrical and Electronic Components

Click to view similar products for [Microprocessors - MPU category](#):

Click to view products by [Micro One manufacturer](#):

Other Similar products are found below :

[MCIMX6D5EYM12AD](#) [A2C00010998 A](#) [ALXD800EEXJCVD C3](#) [LS1020ASE7KQB](#) [LS1020AXE7KQB](#) [A2C00010729 A](#)
[T1022NSE7MQB](#) [T1024NXE7PQA](#) [T1042NSN7WQB](#) [MPC8313EVRADDC](#) [BOXSTCK1A8LFCL](#) [LS1021ASE7KQB](#) [LS1021ASN7KQB](#)
[T1024NXN7MQA](#) [T2080NXE8MQB](#) [T2080NXN8PTB](#) [MCIMX6L3EVN10AB](#) [T2080NXE8PTB](#) [T1024NXE7MQA](#) [CM8063501521600S](#)
[R19L](#) [LS1043AXE7MQB](#) [T1024NXN7PQA](#) [LS1043ASE7QQB](#) [LS1012AXE7HKA](#) [T4240NSN7PQB](#) [MVF30NN152CKU26](#)
[FH8067303534005S](#) [R3ZM](#) [R9A07G044L24GBG#AC0](#) [SVF311R3K2CKU2](#) [HW8076502640002S](#) [R38F](#) [R7S721030VLFP#AA0](#)
[M0516LBN](#) [MCF5208CVM166](#) [MCIMX6S6AVM08AC](#) [MCIMX6U5DVM10AC](#) [TEN54LSDV23GME](#) [MC68302AG33C](#) [MC68302EH16C](#)
[MCF5233CVM150](#) [MCIMX6D6AVT10AD](#) [MCIMX6G1CVM05AB](#) [MPC8314ECVRAGDA](#) [MPC8314VRAGDA](#) [MPC8315VRAGDA](#)
[MPC8541VTAPF](#) [PIC16F1828-I/SS](#) [PIC16F690T-I/SS](#) [PIC16F877-20/PQ](#) [PIC16F727-I/PT](#) [PIC16F1823-I/SL](#)