



## Voltage Detectors , ME2808 Series

### General Description

**ME2808 Series** are a set of three-terminal low power voltage detectors implemented in NMOS technology. Each voltage detector in the series detects a particular fixed voltage ranging from 2.0V to 7.0V. The voltage detectors consist of a high precision and low power consumption standard voltage source, a comparator, hysteresis circuit, and an output driver. NMOS technology ensures low power consumption.

### Features

- Highly accuracy:  $\pm 1\%$
- Low power consumption: TYP 1.8uA ( $V_{in}=3V$ )
- Detect voltage range : 2.0V~7.0V in 0.1V increments
- Operating voltage range: 1.5V~18V
- Detect voltage temperature characteristics:  
TYP  $\pm 0.9mV/^{\circ}C$
- Output configuration: NMOS
- Package: SOT23, SOT23-3, SOT23-5, SOT89-3, TO-92

### Typical Application

- battery checkers
- Level selectors
- Power failure detectors
- Microcomputer reset
- Battery backup of Memories
- Store non-volatile RAM signal protectors

### Package

- 3-pin SOT23、SOT23-3、SOT89-3、TO-92
- 5-pin SOT23-5

### Typical Application Circuit

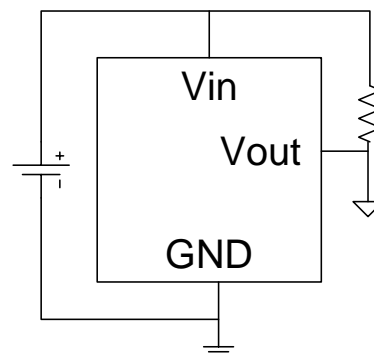

## Selection Guide

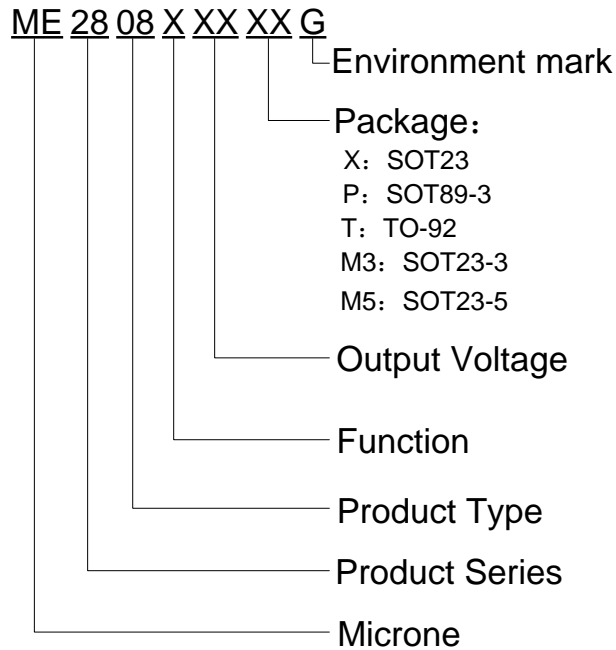

product series	product description
ME2808A25XG	V <sub>OUT</sub> =2.5V; Rising edge detection; Package: SOT23
ME2808A36XG	V <sub>OUT</sub> =3.6V; Rising edge detection; Package: SOT23
ME2808A22M3G	V <sub>OUT</sub> =2.2V; Rising edge detection; Package: SOT23-3
ME2808A33M3G	V <sub>OUT</sub> =3.3V; Rising edge detection; Package: SOT23-3
ME2808A60M3G	V <sub>OUT</sub> =6.0V; Rising edge detection; Package: SOT23-3
ME2808A30PG	V <sub>OUT</sub> =3.0V; Rising edge detection; Package: SOT89-3
ME2808A27TG	V <sub>OUT</sub> =2.7V; Rising edge detection; Package: TO-92
ME2808A42M5G	V <sub>OUT</sub> =4.2V; Rising edge detection; Package: SOT23-5
ME2808B28M3G	V <sub>OUT</sub> =2.8V; Falling edge detection; Package: SOT23-3

**NOTE:** At present ,there are eighteen kinds of voltage value: 2.2V、2.4V、2.5V、2.7V、2.8V、3.0V、3.2V、3.3V、3.5V、3.6V、3.8V、3.9V、4.0V、4.2V、4.3V、4.5V、5.0V、6.0V。If you need other voltage and package, please contact our sales staff.

## Pin Configuration

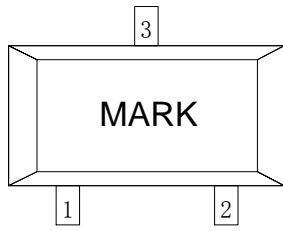

SOT23

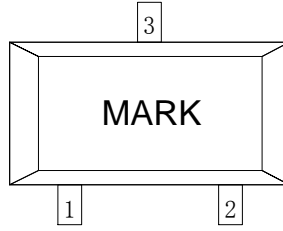

SOT23-3

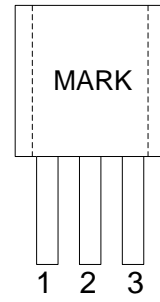

TO-92

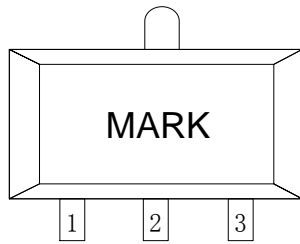

SOT89-3

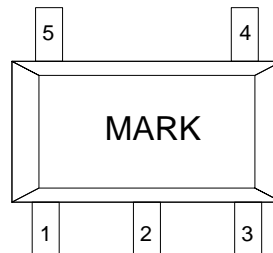

SOT23-5

## Pin Assignment

Pin Number					Pin Name	Functions
SOT23	SOT23-3	SOT23-5	SOT89-3	TO-92		
2	2	3	3	3	GND	Ground
1	1	1	1	1	$V_{OUT}$	Output Voltage
3	3	2	2	2	$V_{IN}$	Input Voltage
		4			NC	No Connection
		5			NC	No Connection

## Block Diagram

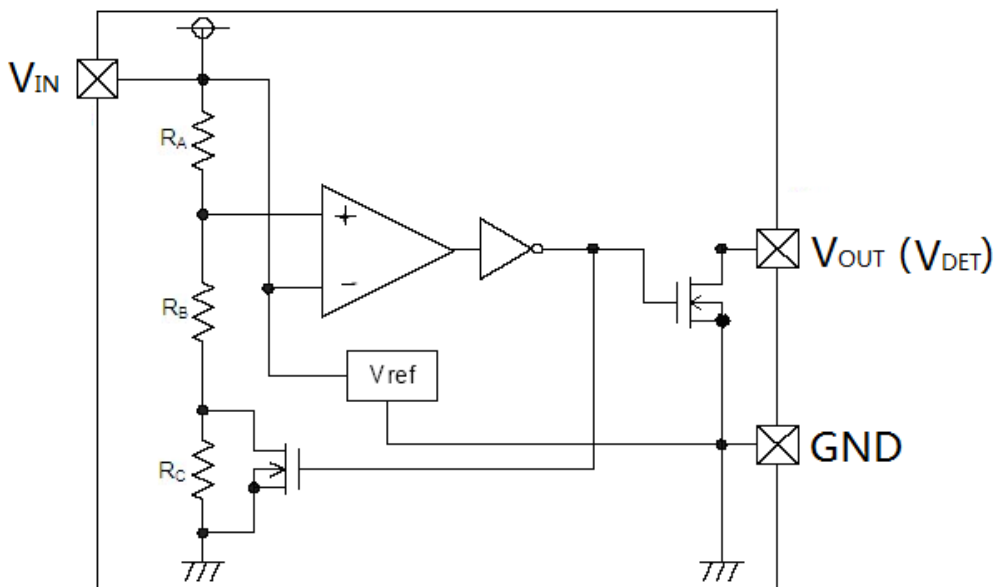

## Absolute Maximum Ratings

PARAMETER		SYMBAL	RATINGS	UNITS
V <sub>IN</sub> Input Voltage		V <sub>IN</sub>	18	V
Output Current		I <sub>OUT</sub>	50	mA
Output Voltage	NMOS	V <sub>OUT</sub>	GND-0.3~ V <sub>IN</sub> +0.3	V
Continuous Total Power Dissipation	SOT23	P <sub>D</sub>	250	mW
	SOT23-3/5		300	
	SOT89-3		500	
	TO-92		500	
Operating Ambient Temperature		T <sub>Opr</sub>	-40~+85	°C
Storage Temperature		T <sub>stg</sub>	-50~+125	°C
Soldering temperature and time		T <sub>solder</sub>	260°C, 10s	

## Electrical Characteristics (V<sub>DET</sub> =2.0V to 7.0V ,T<sub>A</sub>=25°C ,unless otherwise noted)

Parameter	Symbol	Conditions		Min.	Typ.	Max.	Units
V <sub>DET</sub>	Detect Voltage			V <sub>DET</sub> ×0.99	V <sub>DET</sub>	V <sub>DET</sub> ×1.01	V
V <sub>HYS</sub>	Hysteresis Width			V <sub>DET</sub> ×0.02	V <sub>DET</sub> ×0.05	V <sub>DET</sub> ×0.1	V
I <sub>IN</sub>	Operating Current	V <sub>DET</sub> =2.0V~ 2.8V	V <sub>IN</sub> =3.0V	-	1.8	3	μA
		V <sub>DET</sub> =2.8V~ 3.6V	V <sub>IN</sub> =4.0V	-	1.8	4	
		V <sub>DET</sub> =3.6V ~ 4.7V	V <sub>IN</sub> =5.0V	-	2.1	4	
		V <sub>DET</sub> =4.7V~ 7.0V	V <sub>IN</sub> =8.0V	-	2.5	4	
V <sub>IN</sub>	Operating Voltage	V <sub>DET</sub> =2.0V to 7.0V		0.7	-	18	V
I <sub>OL</sub>	Output Sink Current	V <sub>DET</sub> =2.0V~ 2.8V	V <sub>IN</sub> =-V <sub>DET(S)</sub> -0.2 V , V <sub>OUT</sub> =0.2V	0.5			mA
		V <sub>DET</sub> =2.8V~ 3.6V	V <sub>IN</sub> =-V <sub>DET(S)</sub> -0.5 V , V <sub>OUT</sub> =0.3V	0.5			
		V <sub>DET</sub> =3.6V ~ 4.7V	V <sub>IN</sub> =-V <sub>DET(S)</sub> -0.5 V , V <sub>OUT</sub> =0.3V	1.2			
		V <sub>DET</sub> =4.7V~ 7.0V	V <sub>IN</sub> =-V <sub>DET(S)</sub> -0.5 V , V <sub>OUT</sub> =0.3V	2.5			
ΔV <sub>DET</sub> /ΔT <sub>A</sub>	Temperature characteristics	0°C≤T <sub>opr</sub> ≤70°C			±0.9		mV/°C

- Note:**
- 1、VDF(S) : Specified Detection Voltage value
  - 2、VDF : Actual Detection Voltage value
  - 3、Release Voltage: VDR=VDF+VHYS (ME2808A series)  
VDR=VDF-VHYS (ME2808B series)

## Functional Description

The ME2808 series is a set of voltage detectors equipped with a high stability voltage reference which is connected to the negative input of a comparator — denoted as  $V_{REF}$  in the following figure (Fig. 1). When the voltage drop to the positive input of the comparator (i.e.,  $V_B$ ) is higher than  $V_{REF}$ ,  $V_{OUT}$  goes high, M1 turns off, and  $V_B$  is expressed as  $V_{BH} = V_{IN} \times (R_B + R_C) / (R_A + R_B + R_C)$ . If  $V_{IN}$  is decreased so that  $V_B$  falls to a value that is less than  $V_{REF}$ , the comparator output inverts (from high to low),  $V_{OUT}$  goes low,  $V_C$  is high, M1 turns on,  $R_C$  is bypassed, and  $V_B$  becomes:  $V_{BL} = V_{IN} \times R_B / (R_A + R_B)$ , which is less than  $V_{BH}$ . By so doing the comparator out-put will stay low to prevent the circuit from oscillating when  $V_B \approx V_{REF}$ . If  $V_{IN}$  falls below the minimum operating voltage, the output becomes undefined. When  $V_{IN}$  goes from low to  $V_{IN} \times R_B / (R_A + R_B) > V_{REF}$ , the comparator output goes high and  $V_{OUT}$  goes high again. The detection voltage is as defined:

$$V_{DET(-)} = (R_A + R_B + R_C) \times V_{REF} / (R_B + R_C)$$

The release voltage is as defined:

$$V_{DET(+)} = (R_A + R_B) \times V_{REF} / R_B$$

The hysteresis width is:

$$V_{HYS} = V_{DET(+)} - V_{DET(-)}$$

Fig.1 demonstrates the NMOS output type with positive output polarity ( $V_{OUT}$  is normally high, active low).

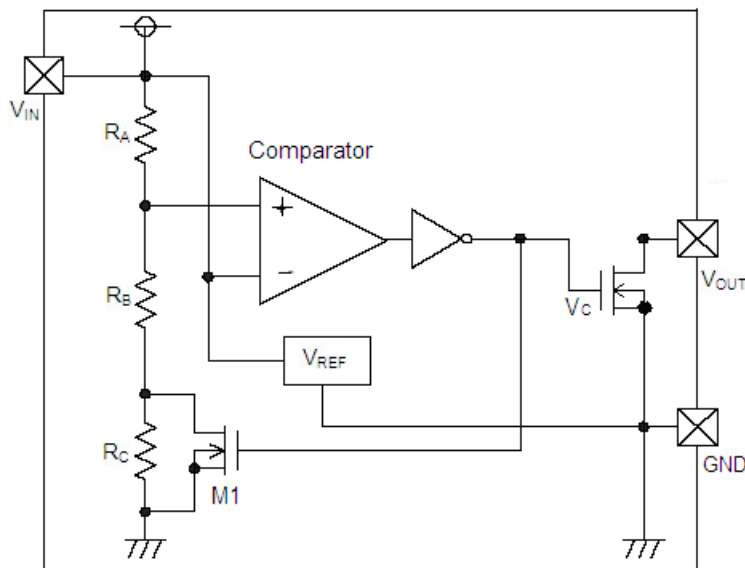
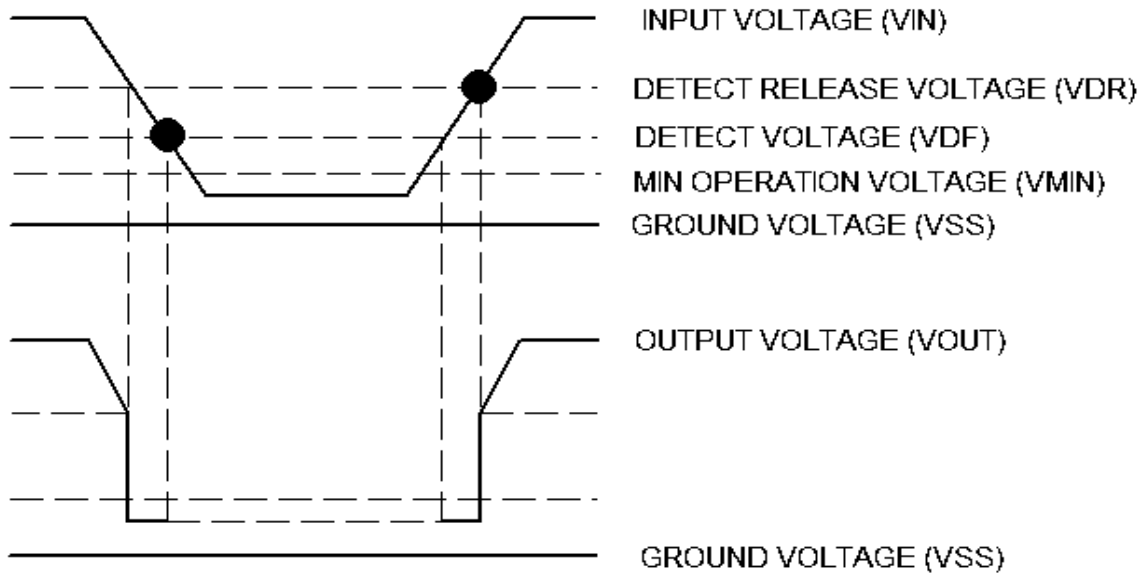

Fig.1 NMOS output voltage detector (ME2808)

## Timing Chart

ME2808A:



ME2808B:

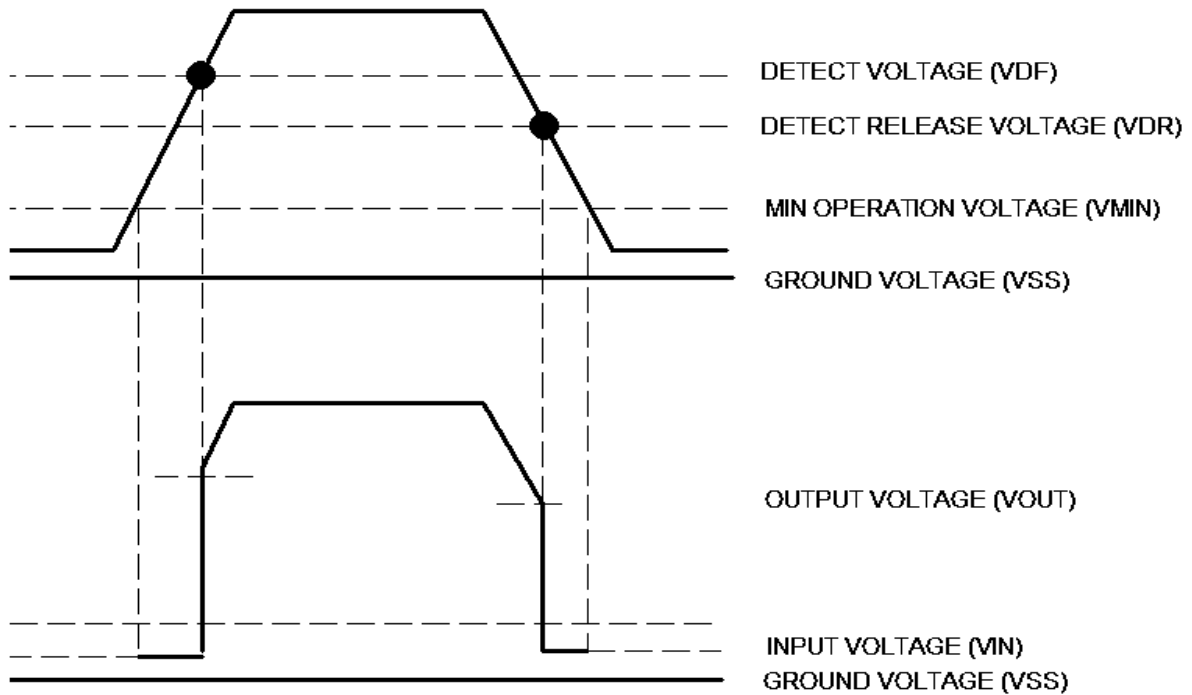

## Packaging Information

● SOT23

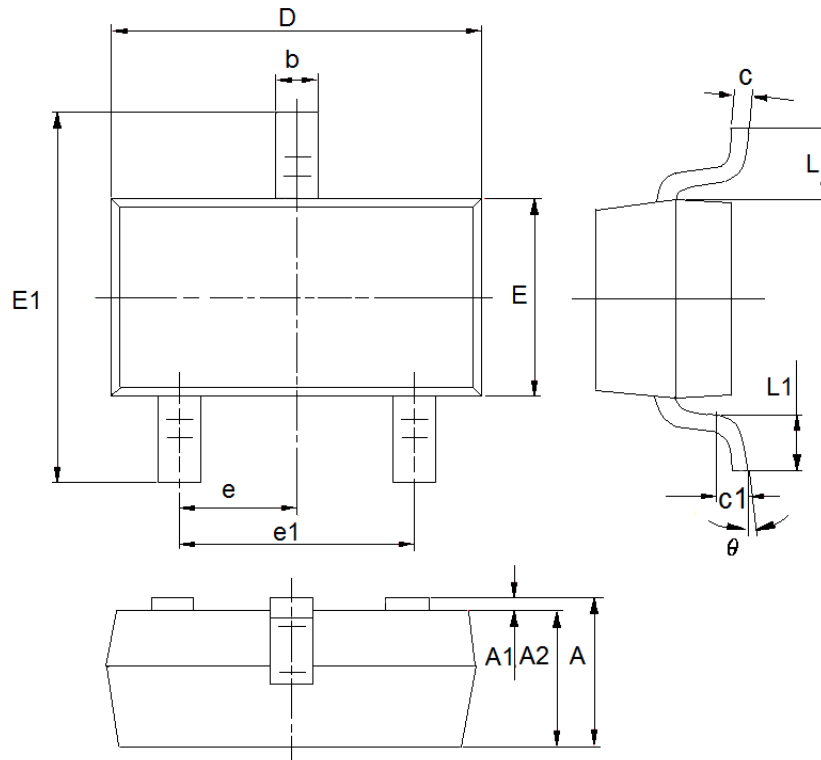

DIM	Millimeters		Inches	
	Min	Max	Min	Max
A	0.9	1.2	0.0354	0.0472
A1	0	0.14	0.0000	0.0055
A2	0.9	1.05	0.0354	0.0413
b	0.28	0.52	0.0110	0.0205
c	0.07	0.23	0.0028	0.0091
D	2.8	3.0	0.1102	0.1181
e1	1.8	2.0	0.0709	0.0787
E	1.2	1.4	0.0472	0.0551
E1	2.2	2.6	0.0866	0.1024
e	0.95(TYP)		0.0374(TYP)	
L	0.55(TYP)		0.0217(TYP)	
L1	0.25	0.55	0.0098	0.0217
theta	0	8°	0.0000	8°
c1	0.25(TYP)		0.0098(TYP)	

● SOT23-3

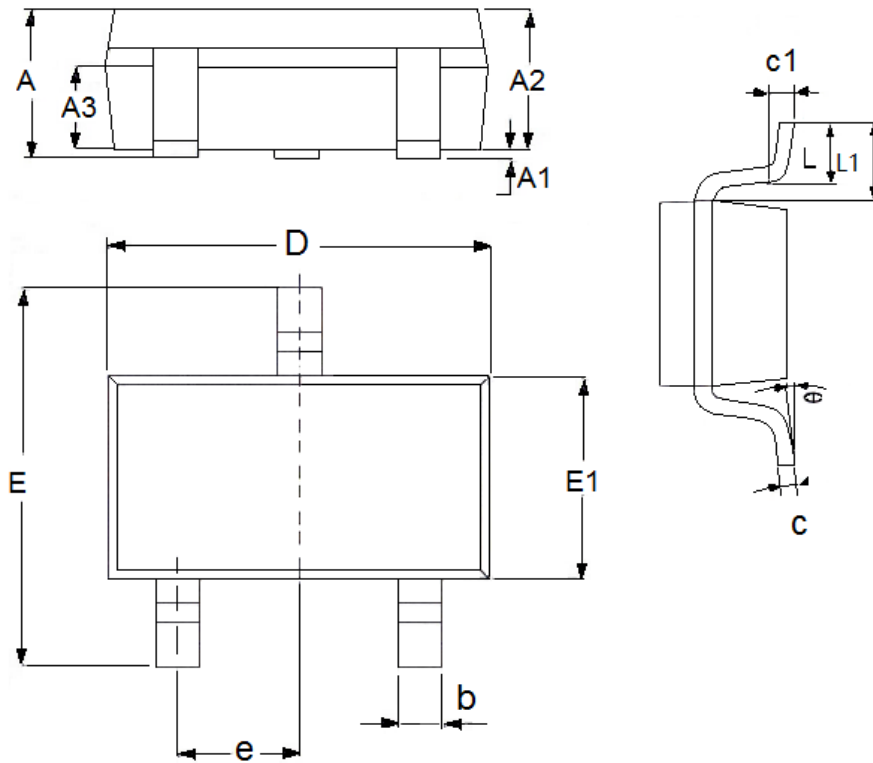

DIM	Millimeters		Inches	
	Min	Max	Min	Max
A	1	1.5	0.0394	0.0591
A1	0	0.15	0.0000	0.0059
A2	0.9	1.3	0.0354	0.0512
A3	0.6	0.7	0.0236	0.0276
b	0.25	0.5	0.0098	0.0197
c	0.1	0.25	0.0039	0.0098
D	2.8	3.1	0.1102	0.1220
E	2.6	3.1	0.1023	0.1220
E1	1.5	1.8	0.0591	0.0709
e	0.95(TYP)		0.0374(TYP)	
L	0.25	0.6	0.0098	0.0236
L1	0.59(TYP)		0.0232(TYP)	
θ	0	8°	0.0000	8°
c1	0.2(TYP)		0.0079(TYP)	
L1	0.59(TYP)		0.0232(TYP)	
θ	0	8°	0.0000	8°
c1	0.2(TYP)		0.0079(TYP)	



● SOT89-3

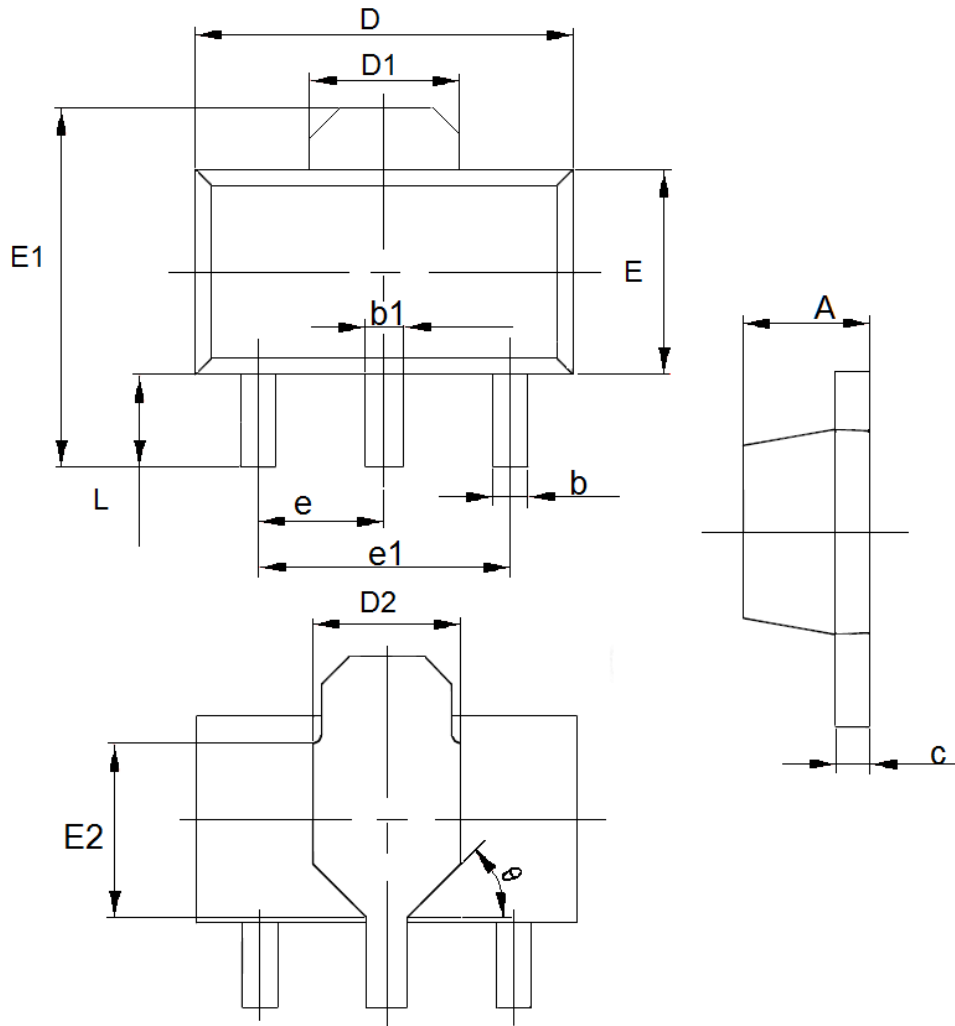

DIM	Millimeters		Inches	
	Min	Max	Min	Max
A	1.4	1.6	0.0551	0.0630
b	0.32	0.52	0.0126	0.0205
b1	0.4	0.58	0.0157	0.0228
c	0.35	0.45	0.0138	0.0177
D	4.4	4.6	0.1732	0.1811
D1	1.55(TYP)		0.061(TYP)	
D2	1.75(TYP)		0.0689(TYP)	
e1	3.0(TYP)		0.1181(TYP)	
E	2.3	2.6	0.0906	0.1023
E1	3.94	4.4	0.1551	0.1732
E2	1.9(TYP)		0.0748(TYP)	
e	1.5(TYP)		0.0591(TYP)	
L	0.8	1.2	0.0315	0.0472
θ	45°		45°	

● SOT23-5

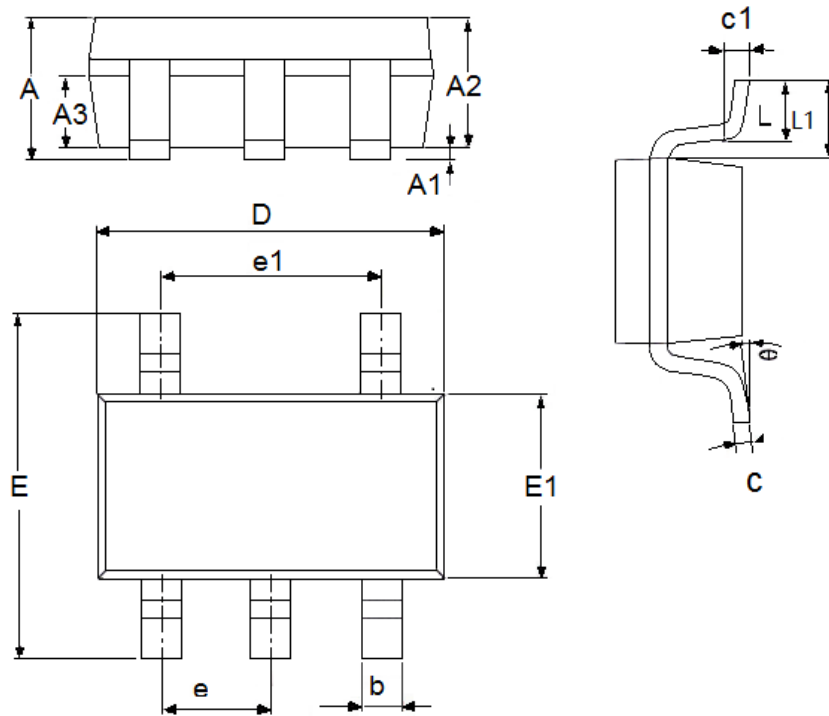

DIM	Millimeters		Inches	
	Min	Max	Min	Max
A	0.9	1.45	0.0354	0.0571
A1	0	0.15	0.0000	0.0059
A2	0.9	1.3	0.0354	0.0512
A3	0.6	0.7	0.0236	0.0276
b	0.25	0.5	0.0098	0.0197
c	0.1	0.26	0.0039	0.0102
D	2.8	3.1	0.1102	0.1220
e1	1.9(TYP)		0.0748(TYP)	
E	2.6	3.1	0.1024	0.1201
E1	1.5	1.8	0.0512	0.0709
e	0.95(TYP)		0.0374(TYP)	
L	0.25	0.6	0.0098	0.0236
L1	0.59(TYP)		0.0232(TYP)	
θ	0	8°	0.0000	8°
c1	0.2(TYP)		0.0079(TYP)	

● TO-92

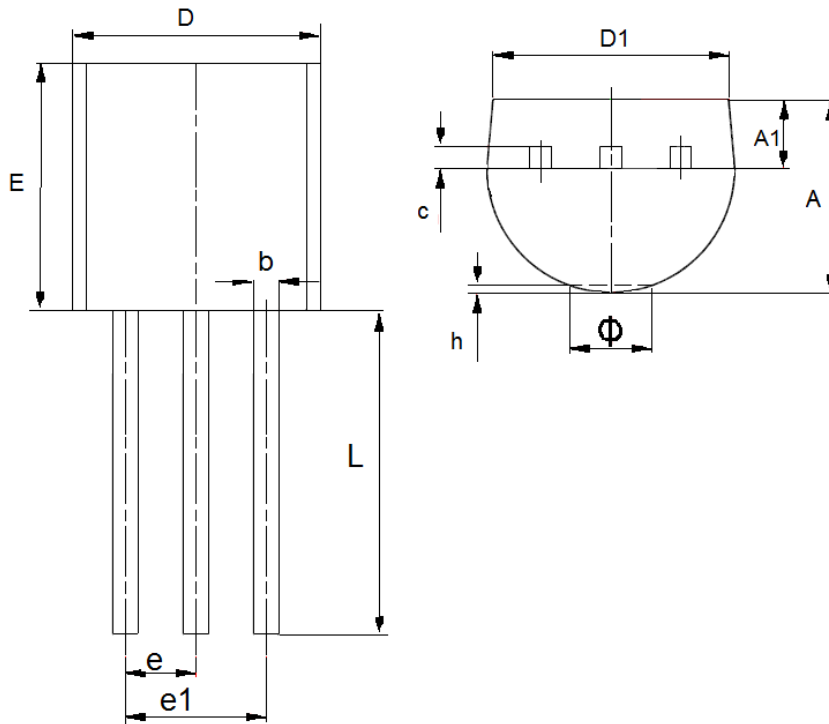

DIM	Millimeters		Inches	
	Min	Max	Min	Max
A	3.3	3.7	0.1299	0.1457
A1	1.1	1.4	0.0433	0.0551
b	0.38	0.55	0.015	0.0217
c	0.36	0.51	0.0142	0.0201
D	4.3	4.7	0.1693	0.185
D1	3.43	—	0.135	—
E	4.3	4.7	0.1693	0.185
e	1.27TYP		0.05TYP	
e1	2.44	2.64	0.0961	0.1039
L	14.1	14.5	0.5551	0.5709
h	0	0.38	0	0.015
Φ	—	1.6	—	0.063

- The information described herein is subject to change without notice.
- Nanjing Micro One Electronics Inc is not responsible for any problems caused by circuits or diagrams described herein whose related industrial properties, patents, or other rights belong to third parties. The application circuit examples explain typical applications of the products, and do not guarantee the success of any specific mass-production design.
- Use of the information described herein for other purposes and/or reproduction or copying without the express permission of Nanjing Micro One Electronics Inc is strictly prohibited.
- The products described herein cannot be used as part of any device or equipment affecting the human body, such as exercise equipment, medical equipment, security systems, gas equipment, or any apparatus installed in airplanes and other vehicles, without prior written permission of Nanjing Micro One Electronics Inc.
- Although Nanjing Micro One Electronics Inc exerts the greatest possible effort to ensure high quality and reliability, the failure or malfunction of semiconductor products may occur. The user of these products should therefore give thorough consideration to safety design, including redundancy, fire-prevention measures, and malfunction prevention, to prevent any accidents, fires, or community damage that may ensue.

## X-ON Electronics

Largest Supplier of Electrical and Electronic Components

*Click to view similar products for [Supervisory Circuits](#) category:*

*Click to view products by [Micro One](#) manufacturer:*

Other Similar products are found below :

[CAT1161LI-25-G](#) [CAT853STBI-T3](#) [TC54VN2402EMB713](#) [MCP1316T-44NE/OT](#) [MCP1316MT-45GE/OT](#) [MCP1316MT-23LI/OT](#)  
[DS1232L](#) [NCV302HSN45T1G](#) [MCP1316T-23LI/OT](#) [PT7M6130NLTA3EX](#) [S-1000N28-I4T1U](#) [CAT1161LI-28-G](#) [MCP1321T-29AE/OT](#)  
[MCP1319MT-47QE/OT](#) [S-1000N23-I4T1U](#) [S-1000N19-I4T1U](#) [CAT824UTDI-GT3](#) [TC54VC2502ECB713](#) [PT7M6133NLTA3EX](#)  
[PT7M6127NLTA3EX](#) [BD48E23G-TR](#) [BD48E49G-TR](#) [BD48E52G-TR](#) [MP6412GQGU-Z](#) [XC61GN2502HR-G](#) [HG810RM3/TR](#)  
[ME2808A33XG](#) [ME2801A33M3G](#) [SGM809B-RXN3LG/TR](#) [HT7033S](#) [UM803RS](#) [UM805RE](#) [BL8506-40CRM](#) [SSP54123](#)  
[SSP61CN1902MR](#) [Aip54123](#) [MAX809C263NR](#) [HE61CN2402MR](#) [UM810MS](#) [MAX809C293NR](#) [MAX809C308NR](#) [HE61CN2702MR](#)  
[UM811SE](#) [XC61CN1902MR](#) [BD48K34G-TL](#) [BL8506-20CRM](#) [CN825R](#) [XC61CC1502MR](#) [XC61CN1802MR](#) [BL8509CCB3TR263DC](#)