

## 5V, 2A Current Mode Synchronous Step-Down DC/DC Converter

### Description

ME3104-N is a current mode synchronous step-down DC/DC converter with an input voltage range of 2.8V to 6V. And the output voltage is set externally.

It works at PFM/PWM mode; it operates in nearly constant switching frequency 1.5MHz (TYP) over the heavy load and works in PFM mode that maintains high efficiency during light load operation.

ME3104-N integrated a few protect circuits to make the system works in safety stations. It contains input Under-Voltage Lockout, over-current protection and short-circuit protection and over temperature protection.

### Feature

- Output current: 2A(TYP)
- Efficiency: 94% (@ $I_{OUT}=500mA$ ,  $V_{out}=3.3V$ )
- Input Voltage: 2.8V~6V
- Feedback Voltage: 0.6V ( $\pm 2.0\%$ )
- Frequency: 1.5MHz (TYP) at PWM model
- PFM/PWM control mode
- Low Dropout Operation: 100% Duty Cycle
- Input Voltage UVLO
- Internally Soft-Start Function
- Over-current protection and short-circuit protection
- Over Temperature protection

### Applications

- Bluetooth, Cable Modem
- LCD TV Power Supply& Metering Platforms
- General Purpose Point-of-Load(POL)
- Mobile devices

### Package

- 5-pin SOT23-5

### Typical Application Circuit

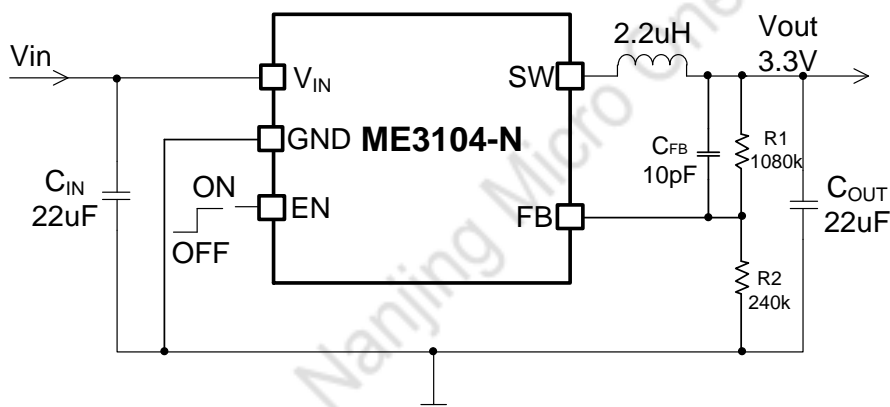

## Selection Guide

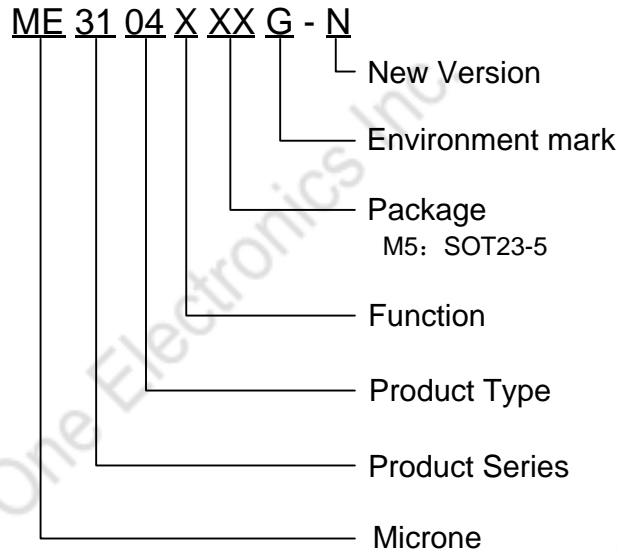

product serie	product description
ME3104AM5G-N	Package: SOT23-5

**NOTE:** If you need other voltage and package, please contact our sales staff.

## Pin Configuration

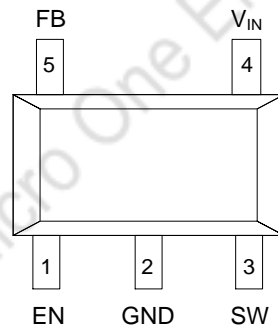

**SOT23-5**

## Pin Assignment

PIN Number	symbol	Function
1	EN	Enable
2	GND	Ground
3	SW	Switch
4	V <sub>IN</sub>	Input
5	FB	Feedback

## Block Diagram

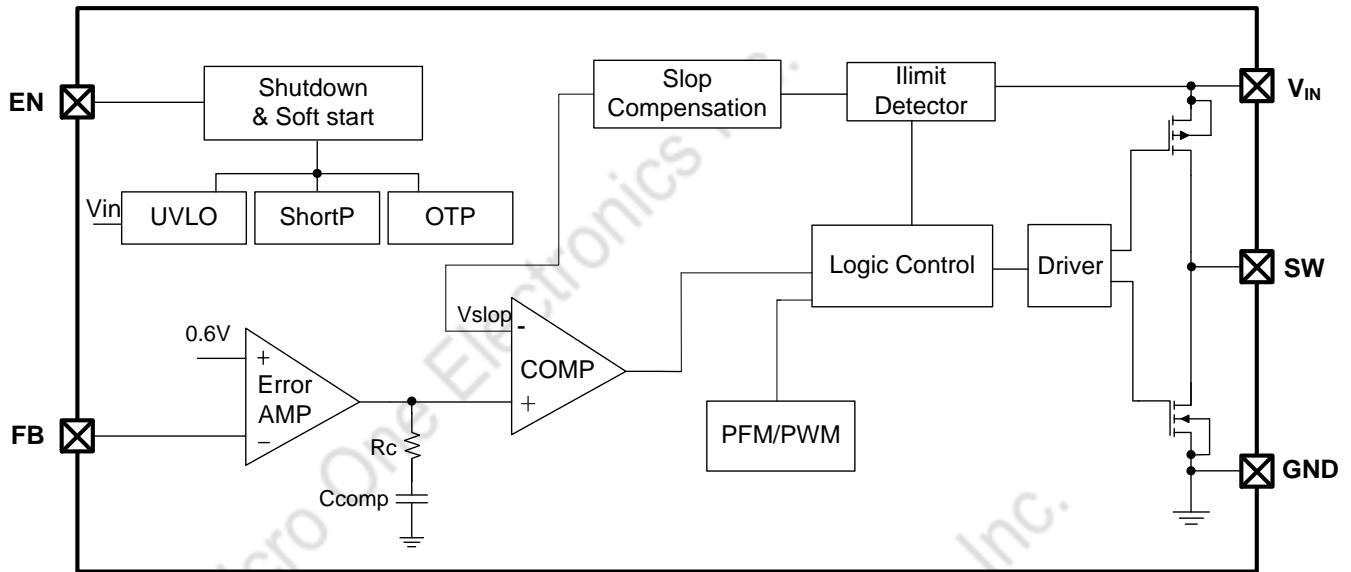

## Absolute Maximum Ratings

Parameter	Symbol	Ratings	Units
Input Voltage	$V_{IN}$	-0.3~6.0	V
SW Pin Voltage	$V_{SW}$	-0.3~6.0	V
EN Pin Voltage	$V_{EN}$	-0.3~6.0	V
FB Pin Voltage	$V_{FB}$	-0.3~6.0	V
Internal Power Dissipation (SOT23-5)	$P_d$	600	mW
Thermal resistance (Junction to air) (SOT23-5)	$\theta_{JA}$	210	$^{\circ}C/W$
Operating Ambient Temperature Range	$T_{Opr}$	-40~+70	$^{\circ}C$
Storage Temperature Range	$T_{stg}$	-55~+150	$^{\circ}C$
Maximum junction temperature	$T_J$	-40~+150	$^{\circ}C$

## Electrical Characteristic

**ME3104-N** test conditions:  $V_{IN}=5V$ ,  $V_{CE}=5V$ ,  $T_{opt}=25^{\circ}C$  unless otherwise noted.

Parameter	Symbol	Condition	Min	Typ	Max	Unit	CIRCUIT
Input Voltage Range	$V_{IN}$		2.8	-	6	V	1
Feedback Voltage	$V_{FB}$		0.588	0.6	0.612	V	1
UVLO Voltage	$V_{UVLO}$	$V_{IN}$ rising	2	2.2	2.4	V	2
		Hysteresis		0.2			
Output Voltage Line Regulation	LNR	$V_{IN}=2.8V$ to $6V$ $I_{OUT}=10mA$	--	--	1	%/V	1
Output Voltage Load Regulation	LDR	$0mA < I_{OUT} < 800mA$	--	--	1	%/V	1
DC Bias Current	$I_q$	$V_{FB}=1V$	-	50	60	$\mu A$	2
	$I_{SBY}$	$V_{EN}=0V$	-	0.0	1.0	$\mu A$	2
Switching Frequency	$F_{OSC}$	$V_{IN}=5V, I_{OUT}=300mA$	1.2	1.5	1.8	Mhz	1
		$V_{FB}=0V$ or $V_{OUT}=0V$	--	500	--	KHz	1
Over-Temperature Threshold	$T_{SD}$	$I_{OUT}=10mA$	--	170	--	$^{\circ}C$	1
	$T_{SDHY}$	$I_{OUT}=10mA$	--	25	--	$^{\circ}C$	1
Switch ON Resistance, High	$R_{PMOS}$	$V_{OUT}=0V, I_{LX}=100mA^{(*1)}$	--	0.110	--	$\Omega$	2
Switch ON Resistance, Low <sup>(*2)</sup>	$R_{NMOS}$		-	0.13	--	$\Omega$	
Peak Current Limit Valley Current Limit <sup>(*2)</sup>	$I_{LIMH}$		--	3.5	--	A	1
Enable Input Voltage	$V_{ENH}$	$V_{FB}=0V$ , Applied voltage to $V_{EN}$ , $V_{SW}$ up to "H" level <sup>(*3)</sup>	1.4	-	6	V	2
	$V_{ENL}$	$V_{FB}=0V$ , Applied voltage to $V_{EN}$ , $V_{SW}$ down to "L" level <sup>(*3)</sup>	GND	-	0.3	V	2
Soft-start Time Short Protection Threshold Voltage	tss	After "H" is fed to CE, the time when Lx pin oscillates	0.1	0.3	0.5	mS	1

**NOTES:** (\*1)  $R_{PMOS} = (V_{IN} - V_{SW}) / 100mA$

(\*2) Design value for the ME3104-N series.

(\*3) "H"= $V_{IN}$ , "L"=GND

## Test Circuits

**Circuit No.1**

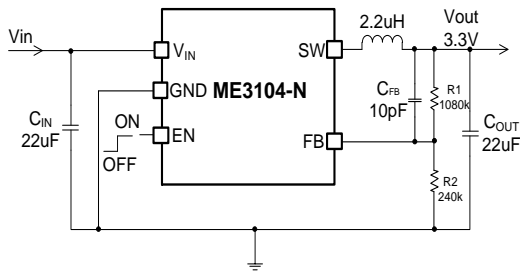

**Circuit No.2**

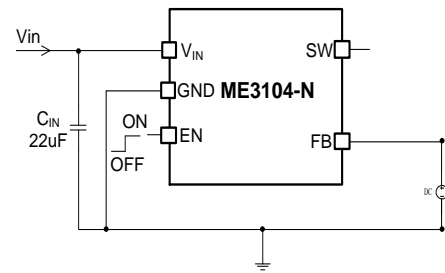

## Operation Principles

The ME3104-N is a synchronous low voltage step-down DC/DC converter that can support the input voltage range of 2.8V to 6V and the output voltage is set externally.

The error amplifier EA adjusts COMP voltage by comparing the feedback signal ( $V_{FB}$ ) from the output voltage with the internal reference. When the load current increases, it causes a drop in the feedback voltage relative to the reference, then the COMP voltage rises to allow higher inductor current to match the load current.

### Soft start

An internal current source charges an internal capacitor to build the soft-start ramp voltage. The  $V_{FB}$  voltage will track the reference voltage during soft-start interval. The typical soft-start time is 0.3ms.

### PFM/PWM Auto change

In PFM/PWM control mode, the ME3104-N works in two states according to the load condition. It adopts PFM mode in light load, PWM mode in heavy load. So the ME3104-N could acquire high efficiency in all over the loads.

### Enable

A logic-high enables the converter; a logic-low forces the device into shutdown mode.

### UVLO

If the  $V_{IN}$  lower than threshold voltage 2V (TYP), the UVLO comparator's output will go high and the switch controller will turn off the high side MOSFET. If the  $V_{IN}$  higher than 2.2V (typical value), the controller will resume the working state.

### Over temperature protection (OTP)

The ME3104-N implements an internal thermal shutdown function when the junction temperature exceeds 170°C (TYP). The thermal shutdown forces the device to stop switching when the junction temperature exceeds the thermal shutdown threshold. Once the temperature decreases below the hysteresis of 25°C (TYP), the device works again.

### 100% Duty Cycle Operation

When the input supply voltage decreases toward the output voltage, the duty cycle increases toward the maximum on-time. Further reduction of the supply voltage forces the main switch to remain on for more than one cycle, eventually reaching 100% duty cycle. The output voltage will then be determined by the input voltage minus the voltage drop across the internal P-MOSFET and the inductor.

### Over Current Protection (OCP) & Short-circuit protection function

The ME3104-N provides over current protection by detecting the high side MOSFET. When the peak current over 3.5A (TYP), the OCP will be triggered. When the OCP is triggered, the ME3104-N will turn off the high side

MOSFET immediately. And the voltage will go down. The ME3104-N has short-circuit protection function. When the output is shorted to ground or  $V_{FB}$  lower than 0.2V, the system works at the lowest frequency 500kHz, to prevent current runaway from occurring.

## Output Voltage Setting

The output voltage is set by an external resistive divider according to the following equation:

$$V_{OUT} = V_{REF} \times (1 + R_1/R_2)$$

**NOTE:** if set output voltage 0.6V, please select  $L=0.5\mu H$ ,  $C_{IN}=C_{OUT}=47\mu F$ .

## Typical Performance Characteristics

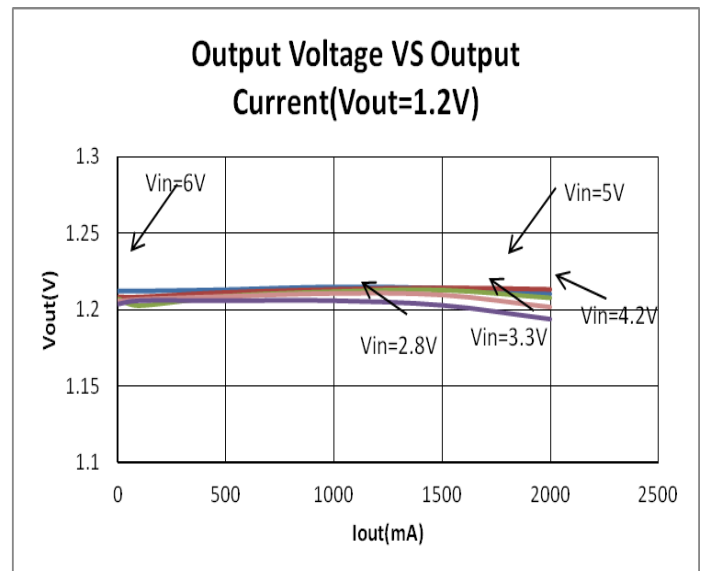
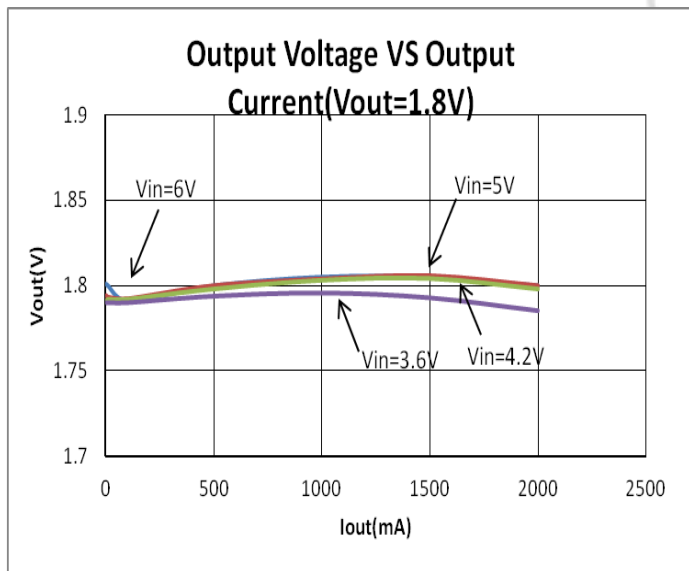
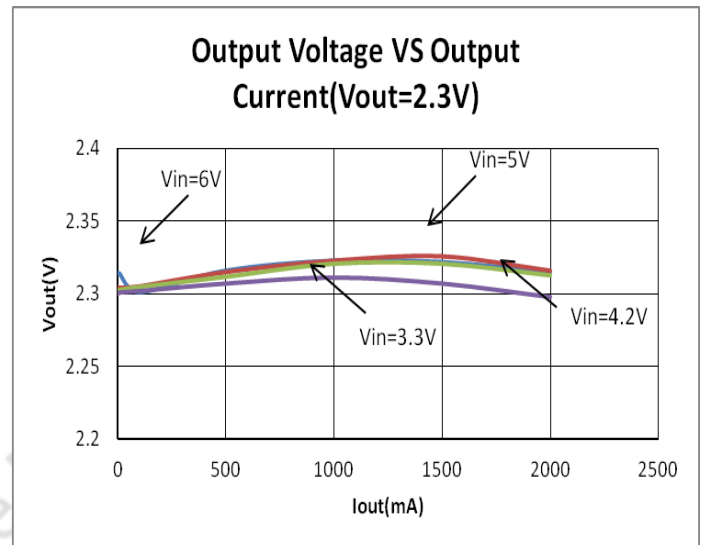
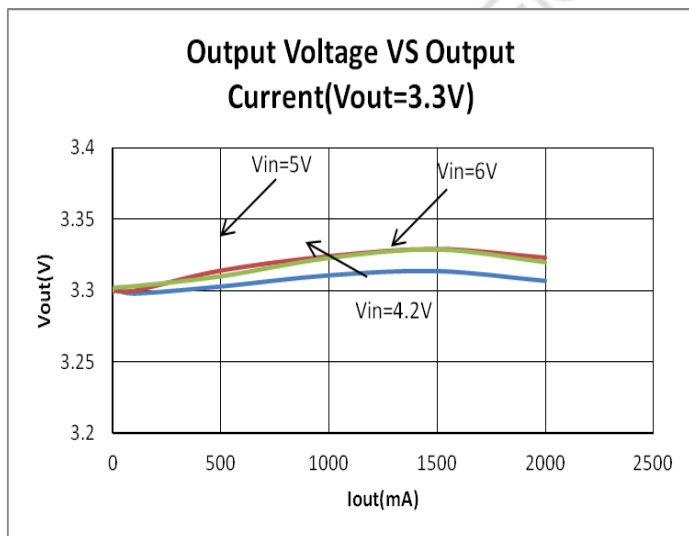

### Efficiency VS Output Current(Vout=3.3V)

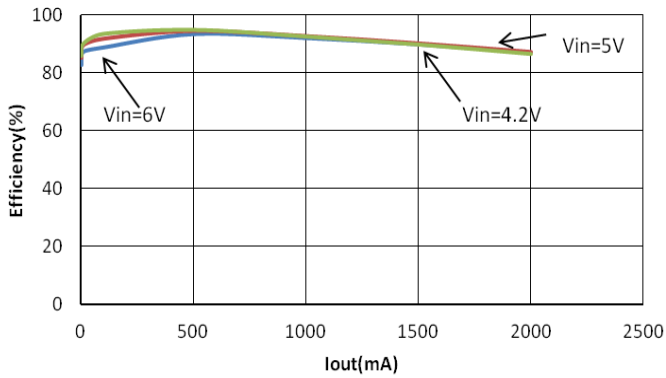

### Efficiency VS Output Current(Vout=2.3V)

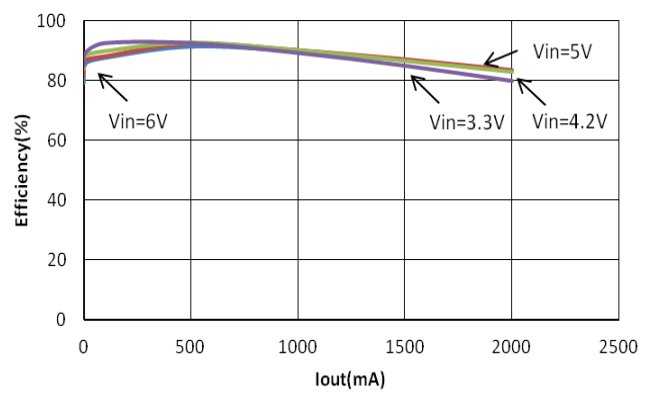

### Efficiency VS Output Current(Vout=1.8V)

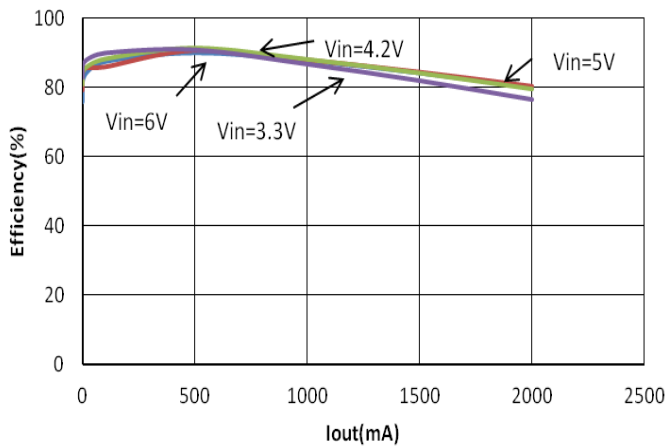

### Efficiency VS Output Current(Vout=1.2V)

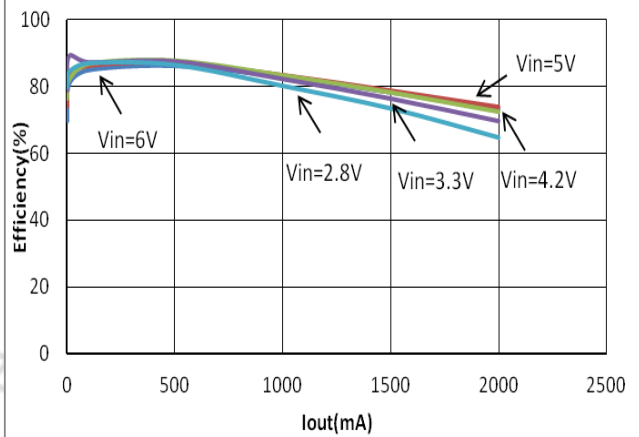

### Feedback Voltage VS Temperature

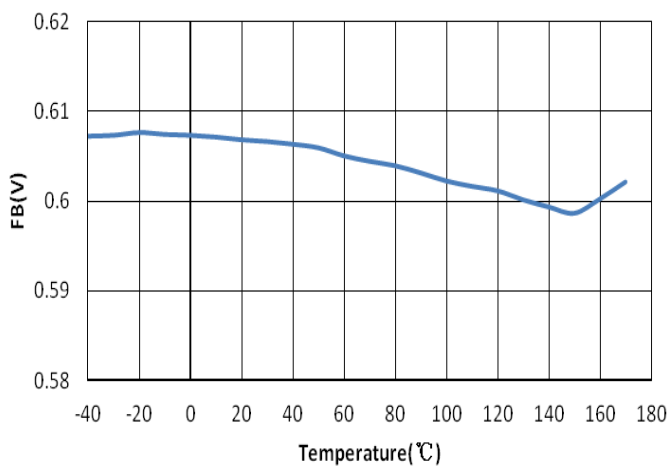

### Oscillator Frequency VS Supply Voltage

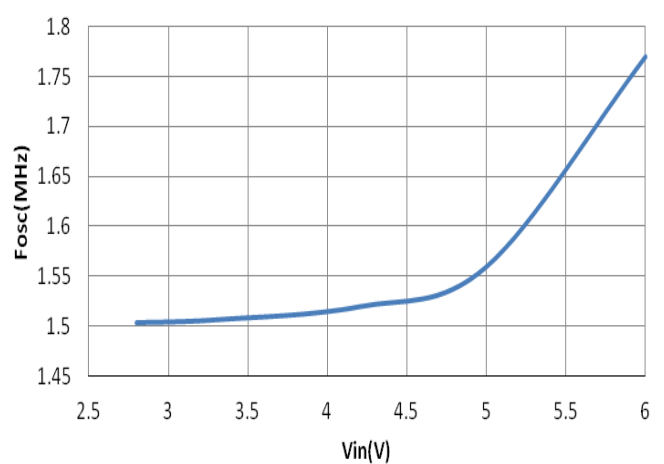

Transient response: Iout=10mA->2A->10mA, Vin=5V, Vout=3.3V, L=2.2uH, Cin=22uF, Cout=47uF F(ceramics)



EN start up: Vout=3.3V Vin=5V Iout=2A

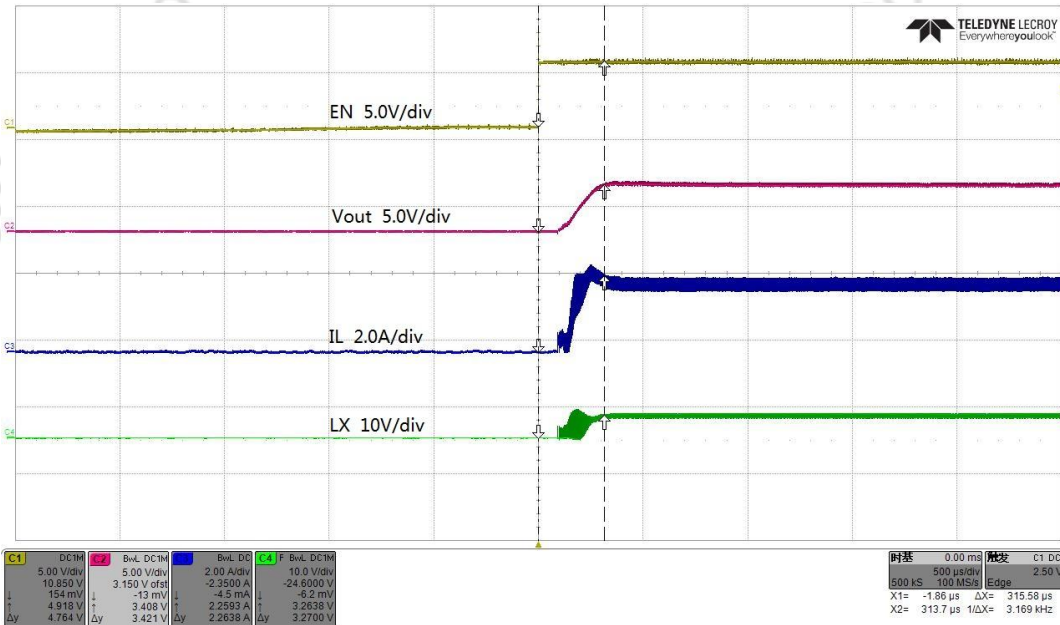

EN shutdown: Vout=3.3V Vin=5V Iout=2A

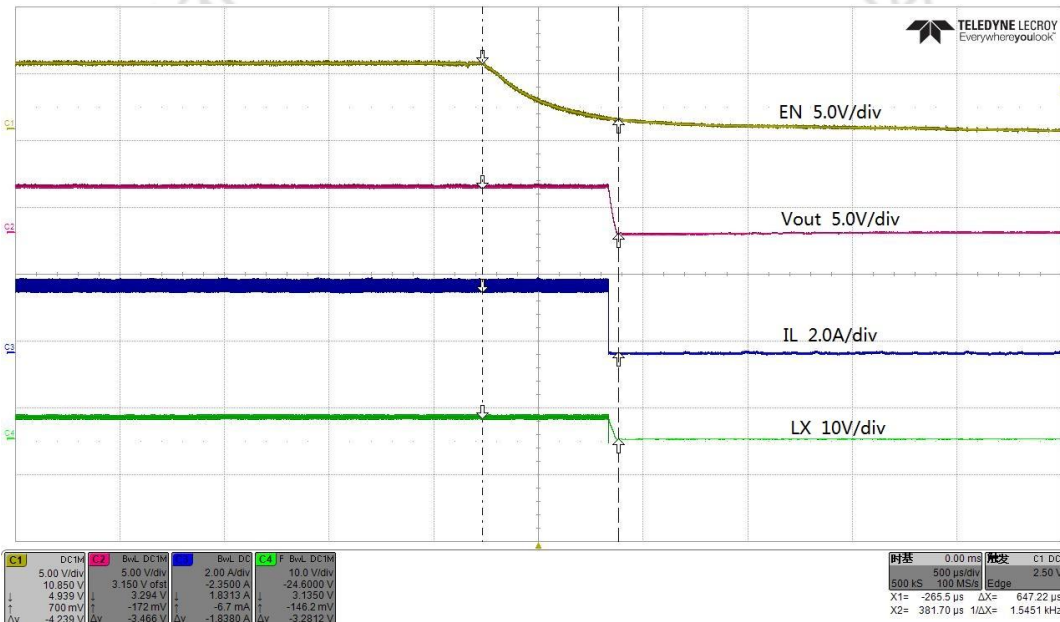



## 封装信息

- 封装类型: SOT23-5

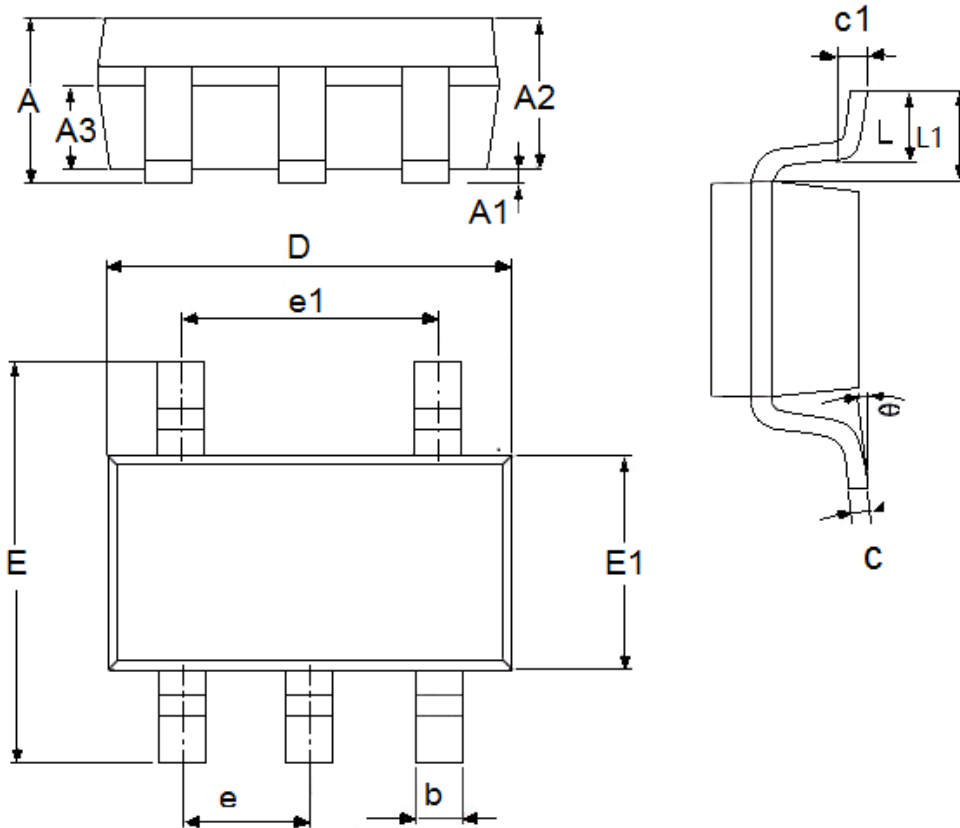

DIM	Millimeters		Inches	
	Min	Max	Min	Max
A	1.05	1.45	0.0413	0.0571
A1	0	0.15	0.0000	0.0059
A2	0.9	1.3	0.0354	0.0512
A3	0.6	0.7	0.0236	0.0276
b	0.25	0.5	0.0098	0.0197
c	0.1	0.23	0.0039	0.0091
D	2.82	3.05	0.1110	0.1201
e1	1.9(TYP)		0.0748(TYP)	
E	2.6	3.05	0.1024	0.1201
E1	1.5	1.75	0.0512	0.0689
e	0.95(TYP)		0.0374(TYP)	
L	0.3	0.6	0.0118	0.0236
L1	0.59(TYP)		0.0232(TYP)	
θ	0	8°	0.0000	8°
c1	0.2(TYP)		0.0079(TYP)	

- The contents of this document will be updated with the product's improvement without prior notice. Please consult our sales staff before using this document to ensure that you are using the latest version.
- The application circuit examples described in this document are only used to indicate the representative use of the product and do not guarantee the design of mass production.
- Please use this product within the limits stated in this document. We will not be responsible for any damage caused by improper use.
- The products described in this document are not allowed to be used in equipment or devices that affect the human body without the written permission of our company, including but not limited to: health equipment, medical equipment, disaster prevention equipment, fuel control equipment, automobile equipment, aviation equipment and vehicle equipment.
- Although our company has always been committed to improving product quality and reliability, semiconductor products have a certain probability of malfunction or wrong work. To prevent personal injury or property damage caused by such accidents, please pay full attention to safety design, for example: Alternate design, fire protection design, and prevention of wrong action design.
- When exporting this product or this document overseas, you should abide by applicable import and export control laws.
- Copying or reprinting part or all of this document in any form without the permission of our company is strictly prohibited.

## X-ON Electronics

Largest Supplier of Electrical and Electronic Components

*Click to view similar products for [Isolated DC/DC Converters](#) category:*

*Click to view products by [Micro One](#) manufacturer:*

Other Similar products are found below :

[PSL486-7LR](#) [Q48T30020-NBB0](#) [JAHW100Y1](#) [SPB05C-12](#) [SQ24S15033-PS0S](#) [CE-1003](#) [CE-1004](#) [MAU228](#) [J80-0041NL](#) [DFC15U48D15](#)  
[XGS-1205](#) [06322](#) [SPB05B-15](#) [L-DA20](#) [DCG40-5G](#) [XKS-2405](#) [DPA423R](#) [vi-m13-cw-03](#) [VI-L53-CV](#) [24IBX15-50-0ZG](#) [HZZ01204-G](#)  
[SPU02L-09](#) [SPU02M-09](#) [SPU02N-09](#) [QUINT4-BUFFER/24DC/40](#) [QUINT4-CAP/24DC/5/4KJ](#) [73-551-5039I](#) [DFC15U48D15G](#) [SEN-6471-](#)  
[1EM](#) [AHV2815DF/HBB](#) [MI-LC21-IX](#) [PAH-48/8.5-D48NB1-C](#) [BM3020-7A](#) [QRS2050P025R06](#) [QRS2050P025K00](#) [CM2320-9EG](#)  
[SKMW15F-05](#) [V300A28H400BF3](#) [TEN 15-1223](#) [TEQ 100-2418WIR](#) [TEQ 160-7218WIR](#) [R05C05TE05S-R](#) [HQA2W085W033V-N07-S](#)  
[AM1SS-2405SJZ](#) [AM2DS-1224SJZ](#) [AM2DS-2405DJZ](#) [AM10SBO-4824SNZ-B](#) [AM15E-2405S-NZ](#) [AM2DS-1212SJZ](#) [AM30SBO-](#)  
[4805SNZ-B](#)