



## Constant Voltage and Constant Current controller ME4313

### General Description

ME4313 is a highly integrated solution for a constant voltage/constant current mode SMPS application.

The ME4313 contains one 1.21V voltage reference with  $\pm 1\%$  accuracy, one current sensing circuit and two operational amplifiers. Combining the voltage reference with one operational amplifier makes ME4313 an ideal voltage controller for use in adapters and battery chargers. The other low voltage reference combined with the other operational amplifier makes it an ideal current limiter for output low side current sensing.

### Typical Application

- Adapters
- Battery Chargers

### Features

- Constant Voltage and Constant Current Control
- Precision Internal Voltage Reference
- Few External Components
- Easy Compensation
- Low supply current: 0.5mA
- Current Control Loop Reference
  - ME4313B: 200mV
  - ME4313C : 70mV
- Operating temperature range:-40 ~ 85°C
- Operating Supply Voltage:2.5V ~ 18V

### Package

- 6-pin SOT23-6

Typical Application Circuit

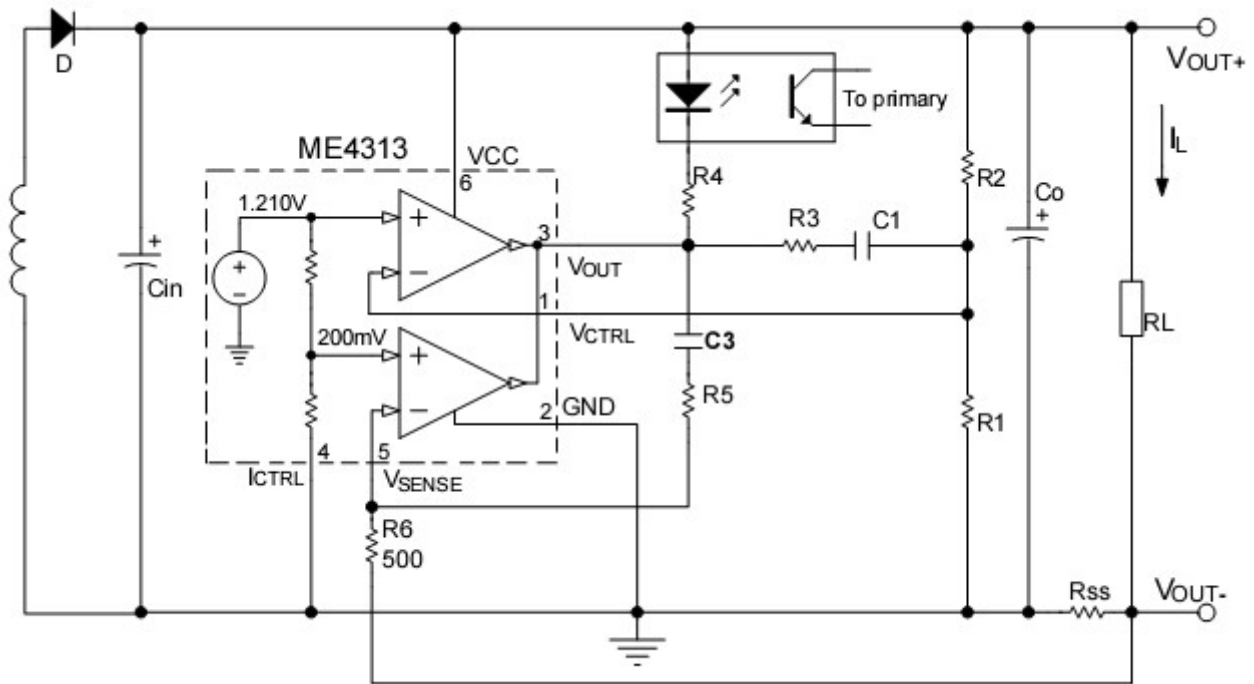

$$V_{OUT} = V_{REF} \times \frac{R1+R2}{R1} - (I_L \times R_{ss}) \text{ (V)}$$

$$\text{CurrentLimit} = \frac{V_{SENSE} \times V_{REF}}{(V_{SENSE} + V_{REF}) R_{ss}} \text{ (A)}$$

Fig.1

## Selection Guide

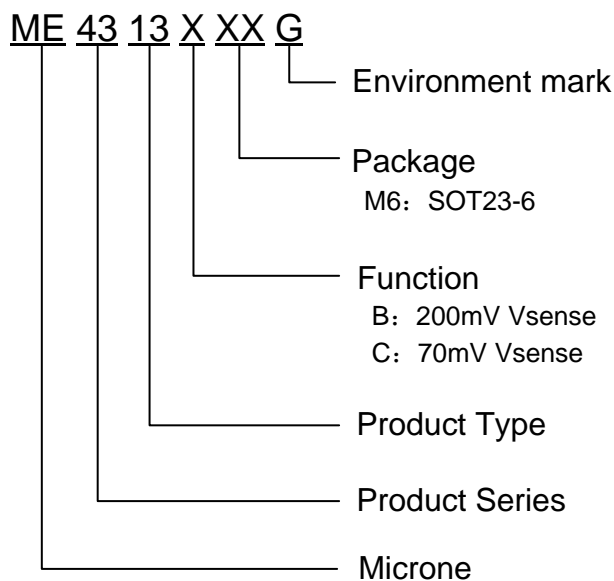

product series	product description
ME4313BM6G	$V_{SENSE} = 200\text{mV}$ ; $1.198 \leq V_{REF} \leq 1.222\text{V}$ ; Package: SOT23-6
ME4313CM6G-1	$V_{SENSE} = 70\text{mV}$ ; $1.198 \leq V_{REF} \leq 1.21\text{V}$ ; Package: SOT23-6
ME4313CM6G-2	$V_{SENSE} = 70\text{mV}$ ; $1.21 \leq V_{REF} \leq 1.222\text{V}$ ; Package: SOT23-6

## Pin Configuration

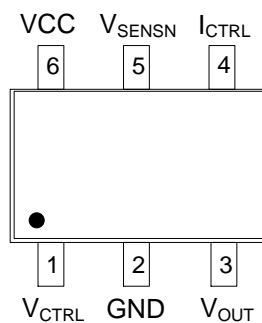

## Pin Assignments

Pin Num.	Symbol	Description
1	$V_{CTRL}$	Input pin of the voltage control loop
2	GND	Ground
3	$V_{OUT}$	Output pin. Sinking current only
4	$I_{CTRL}$	Input pin of the current control loop
5	$V_{SENSE}$	Input pin of the current control loop
6	VCC	Power supply

## Block Diagram

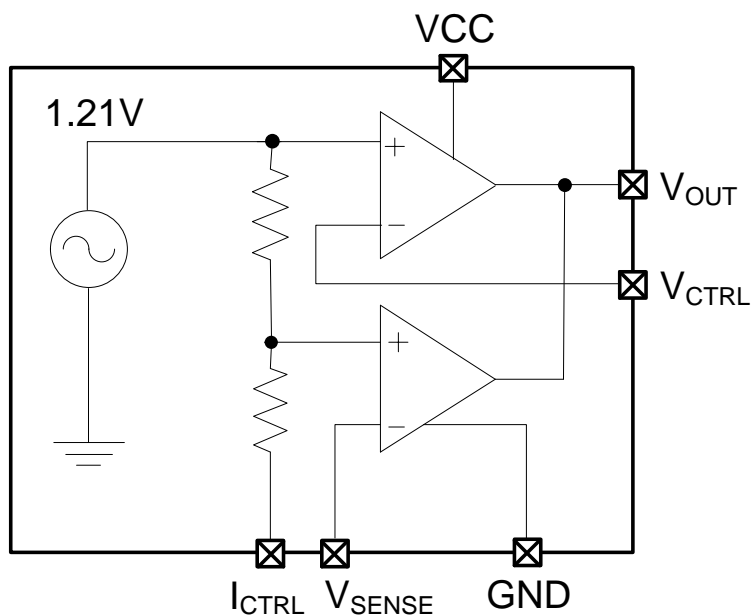

## Absolute Maximum Ratings

Parameter	Range	Unit
Power Supply Voltage VCC	20	V
Input Voltage V <sub>IN</sub>	-0.3 ~ V <sub>CC</sub>	V
Operating Ambient Temperature Range T <sub>A</sub>	-40 ~ +85	°C
Junction Temperature T <sub>J</sub>	-40 ~ +150	°C
Storage Temperature T <sub>STG</sub>	-55 ~ +150	°C
Lead Temperature (Soldering, 5sec) T <sub>LEAD</sub>	260	°C
Thermal resistance (Junction to air) θ <sub>JA</sub>	200	°C/W
Internal Power Dissipation Pd	0.63	W

Caution: The absolute maximum ratings are rated values exceeding which the product could suffer physical damage.

These values must therefore not be exceeded under any conditions.

## Recommended Operating Condition

Parameter	Range	Unit
Power Supply Voltage VCC	2.5 ~ 18	V
Operating Ambient Temperature Range T <sub>A</sub>	-40 ~ 85	°C

## Electrical Characteristics (T<sub>A</sub> = 25°C, VCC=5V, if not otherwise noted)

Symbol	Parameter	Test Conditions	Min	Typ.	Max	Unit	
<b>Total Current Consumption</b>							
I <sub>CC</sub>	Total Supply Current Not Including the Output Sinking Current		-	0.6	1.2	mA	
<b>Voltage Control Loop</b>							
G <sub>mv</sub>	Transconduction Gain (V <sub>CTRL</sub> ). Sink Current Only		1	3.5	-	mA/mV	
V <sub>REF</sub>	Voltage Control Loop Reference	ME4313BM6G	1.198	1.21	1.222	V	
		ME4313CM6G-1	1.198	-	1.21	V	
		ME4313CM6G-2	1.21	-	1.222	V	
I <sub>IBV</sub>	Input Bias Current (V <sub>CTRL</sub> )		-	50	-	nA	
<b>Current Control Loop</b>							
G <sub>mi</sub>	Transconduction Gain (I <sub>CTRL</sub> )		1.5	7	-	mA/mV	
V <sub>SENSE</sub>	Current Control Loop Reference	I <sub>OUT</sub> =2.5mA	B Version	196	200	204	mV
			C Version	66.5	70	73.5	mV
I <sub>IBI</sub>	Current Out of Pin ICTRL at Vsense	B Version		-	25	-	μA
		C Version			18		μA
<b>Output Stage</b>							
V <sub>OL</sub>	Low Output Voltage at 10Ma Sinking Current		-	200	-	mV	
I <sub>OS</sub>	Output Short Circuit Current. Output to VCC.Sink Current Only		-	27	60	mA	

Type Characteristics

Vref vs. Temperature

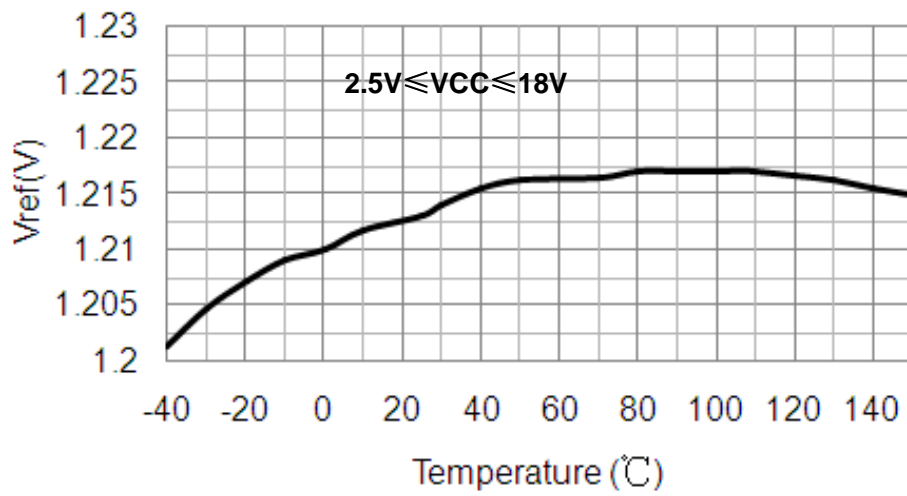

Vsense vs. Temperature

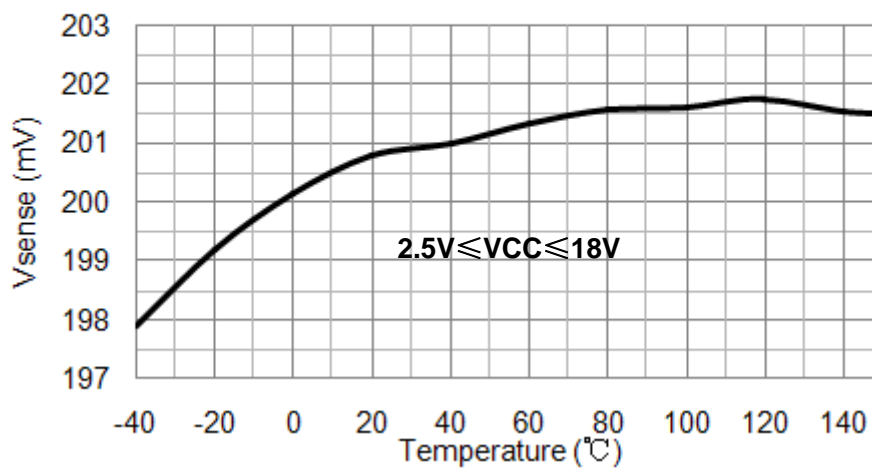

Vsense vs. Temperature

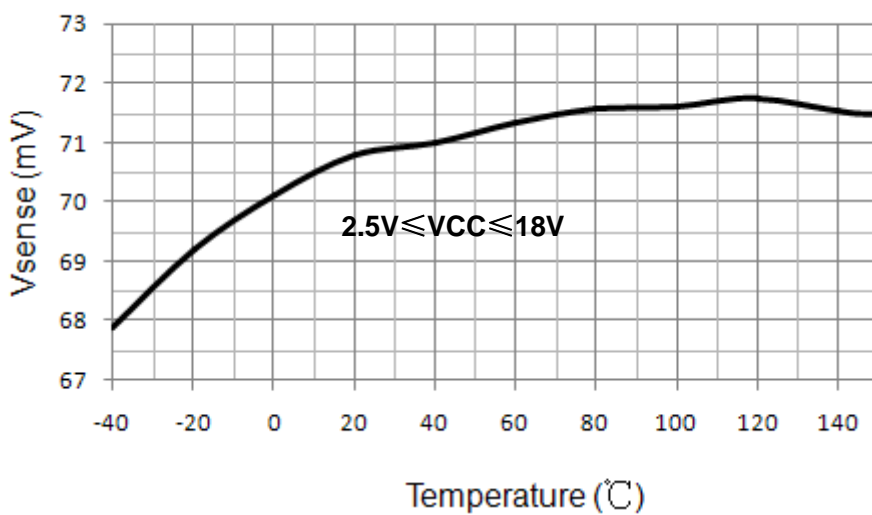

### I<sub>cc</sub> vs. Temperature

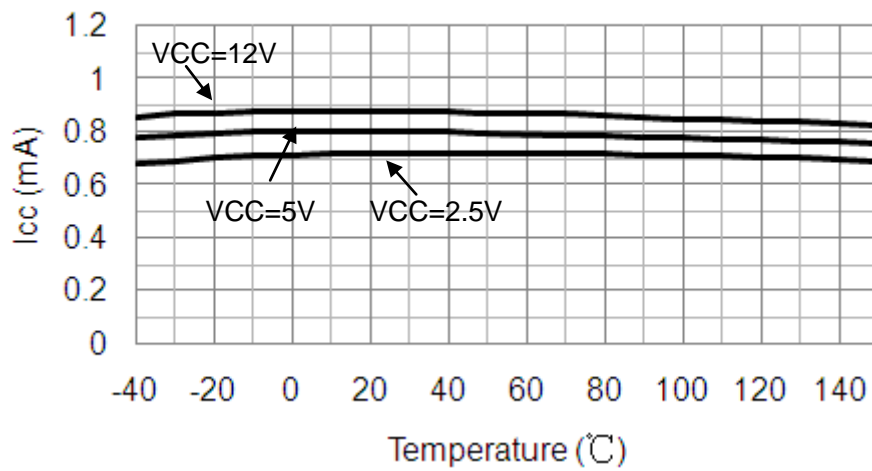

### Output short circuit current $I_{os}$ vs. Temperature

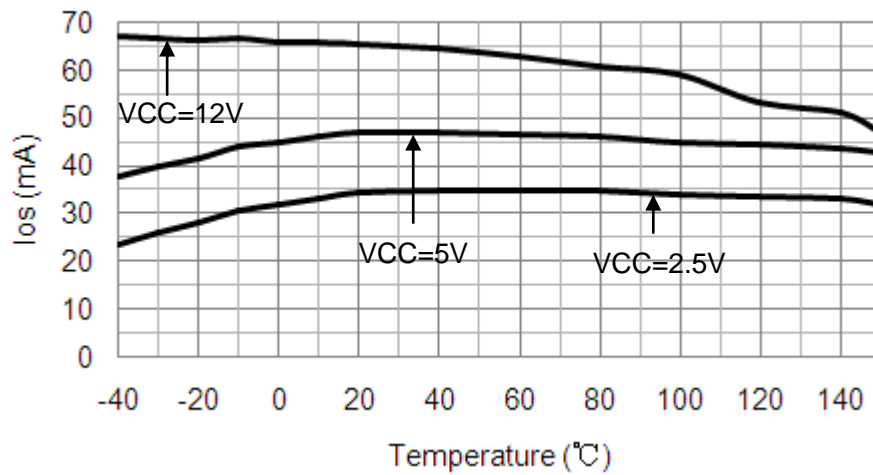

## Packaging Information

- Package Type:SOT23-6

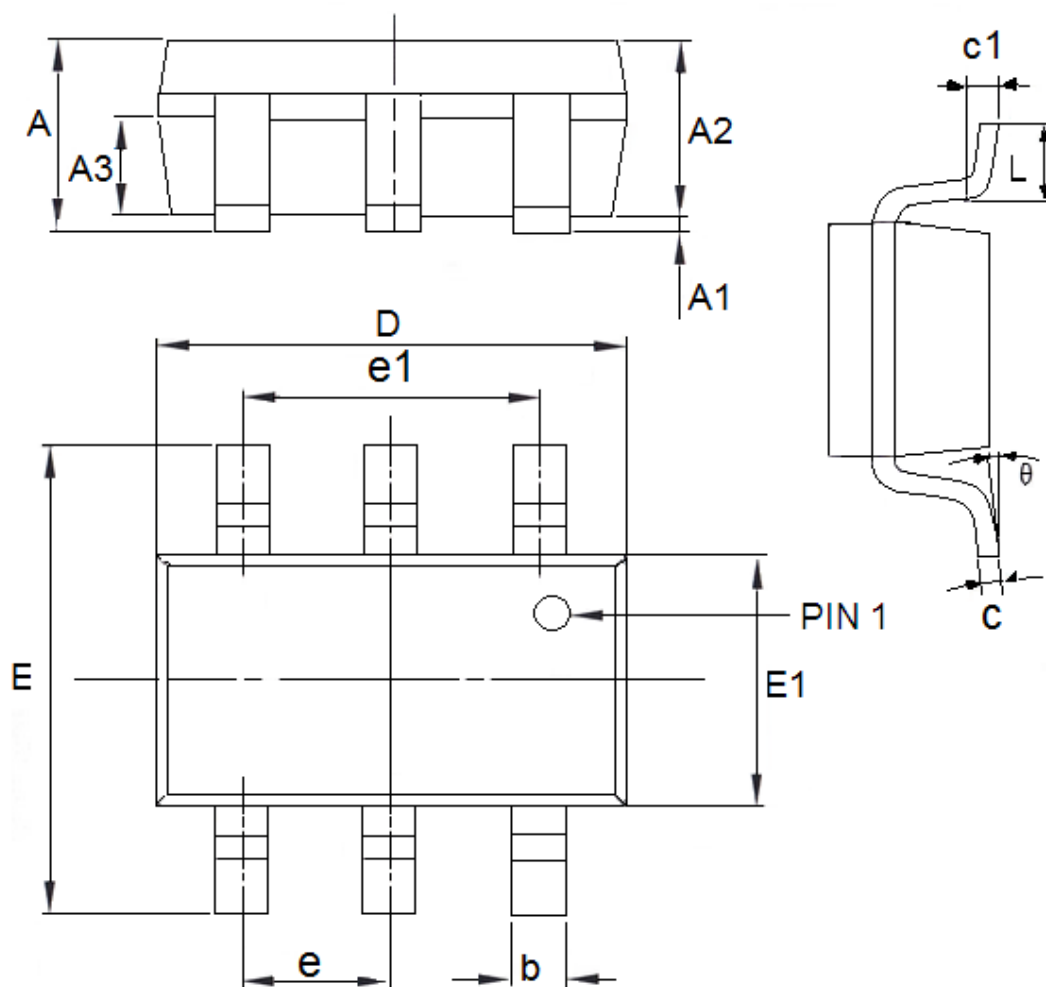

DIM	Millimeters		Inches	
	Min	Max	Min	Max
A	1.05	1.45	0.0413	0.0571
A1	0	0.15	0.0000	0.0059
A2	0.9	1.3	0.0354	0.0512
A3	0.55	0.75	0.0217	0.0295
b	0.25	0.5	0.0098	0.0197
c	0.1	0.25	0.0039	0.0098
D	2.7	3.12	0.1063	0.1228
e1	1.9(TYP)		0.0748(TYP)	
E	2.6	3.1	0.1024	0.1220
E1	1.4	1.8	0.0551	0.0709
e	0.95(TYP)		0.0374(TYP)	
L	0.25	0.6	0.0098	0.0236
theta	0	8°	0.0000	8°
c1	0.2(TYP)		0.0079(TYP)	



- The contents of this document will be updated with the product's improvement without prior notice. Please consult our sales staff before using this document to ensure that you are using the latest version.
- The application circuit examples described in this document are only used to indicate the representative use of the product and do not guarantee the design of mass production.
- Please use this product within the limits stated in this document. We will not be responsible for any damage caused by improper use.
- The products described in this document are not allowed to be used in equipment or devices that affect the human body without the written permission of our company, including but not limited to: health equipment, medical equipment, disaster prevention equipment, fuel control equipment, automobile equipment, aviation equipment and vehicle equipment.
- Although our company has always been committed to improving product quality and reliability, semiconductor products have a certain probability of malfunction or wrong work. To prevent personal injury or property damage caused by such accidents, please pay full attention to safety design, for example: Alternate design, fire protection design, and prevention of wrong action design.
- When exporting this product or this document overseas, you should abide by applicable import and export control laws.
- Copying or reprinting part or all of this document in any form without the permission of our company is strictly prohibited.

## X-ON Electronics

Largest Supplier of Electrical and Electronic Components

*Click to view similar products for [Switching Voltage Regulators](#) category:*

*Click to view products by [Micro One](#) manufacturer:*

Other Similar products are found below :

[FAN53610AUC33X](#) [FAN53611AUC123X](#) [MP2374DS-LF-Z](#) [EN6310QA](#) [NCP81108MNTXG](#) [NCP81109BMNTXG](#) [FAN48610BUC45X](#)  
[FAN48617UC50X](#) [R3](#) [KE177614](#) [EP5358LUA](#) [MPQ4423GQ-AEC1-Z](#) [FAN53611AUC12X](#) [MAX809TTR](#) [NCV891234MW50R2G](#)  
[AST1S31PUR](#) [NCP81103MNTXG](#) [NCP81203PMNTXG](#) [NCP81208MNTXG](#) [NCP81109GMNTXG](#) [SCY1751FCCT1G](#)  
[NCP81109JMNTXG](#) [MP2161AGJ-Z](#) [NCP81241MNTXG](#) [MP2388GQEU-Z](#) [MPQ4481GU-AEC1-P](#) [MP8756GD-P](#) [MPQ2171GJ-P](#)  
[IR3888MTRPBFAUMA1](#) [MPQ2171GJ-AEC1-P](#) [MP2171GJ-P](#) [NCV1077CSTBT3G](#) [MP28160GC-Z](#) [MPM3509GQVE-AEC1-P](#)  
[LTM4691EV#PBF](#) [XCL207A123CR-G](#) [XDPE132G5CG000XUMA1](#) [XDPE12284C0000XUMA1](#) [LTM4691IV#PBF](#) [MP5461GC-P](#)  
[MP28301GG-P](#) [MIC23356YFT-TR](#) [ISL95338IRTZ](#) [MP3416GJ-P](#) [BD9S201NUX-CE2](#) [ISL9113AIRAZ-T](#) [MP5461GC-Z](#) [MPQ2172GJ-](#)  
[AEC1-Z](#) [MPQ4415AGQB-Z](#) [MPQ4590GS-Z](#)