



1A High Speed LDO Regulators ME6118 Series

General Description

The ME6118 series are highly accurate, low noise, LDO Voltage Regulators that are capable of providing an output current that is in excess of 1A with a maximum dropout voltage of 1.3V at 1A (ME6118 A33). This series contains eight fixed output voltages of 0.75V, 1.2V, 1.8V, 2.5V, 3.3V, 3.6V, 4.3V and 5.0V that have no minimum load requirement to maintain regulation. On chip trimming adjusts the reference/output voltage to within $\pm 2\%$ accuracy. Internal protection features consist of output current limiting, safe operating area compensation, and thermal shutdown. The ME6118 series can operate with up to 18V input.

Features

- Output Current in Excess of 1A
- Dropout Voltage: 80mV @ $I_{OUT} = 100\text{mA}$ (ME6118A33)
- Operating Voltage Range:
2.5V ~ 18V ($V_{OUT} \geq 1.2\text{V}$)
2.5V ~ 8V ($V_{OUT} = 0.75\text{V}$)
- Highly Accuracy: $\pm 2\%$
- Standby Current: 52uA (TYP.)
- High Ripple Rejection: 70dB @ 1KHz (ME6118A33)
- Line Regulation: 2mV (TYP.)
- Temperature Stability $\leq 0.5\%$
- Thermal Shutdown Protection: 160°C

Typical Application

- Consumer and Industrial Equipment Point of Regulation
- Switching Power Supply Post Regulation
- Hard Drive Controllers
- Battery Chargers

Package

- 3-pin SOT223, SOT23-3, SOT89-3, TO252-2
- 8-pin DFN3*3-8 (P=0.65)

Typical Application Circuit

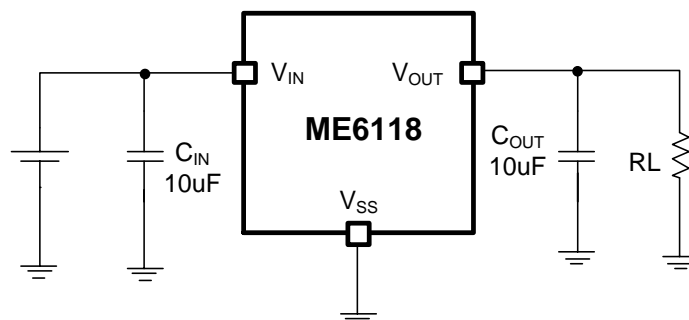

Selection Guide

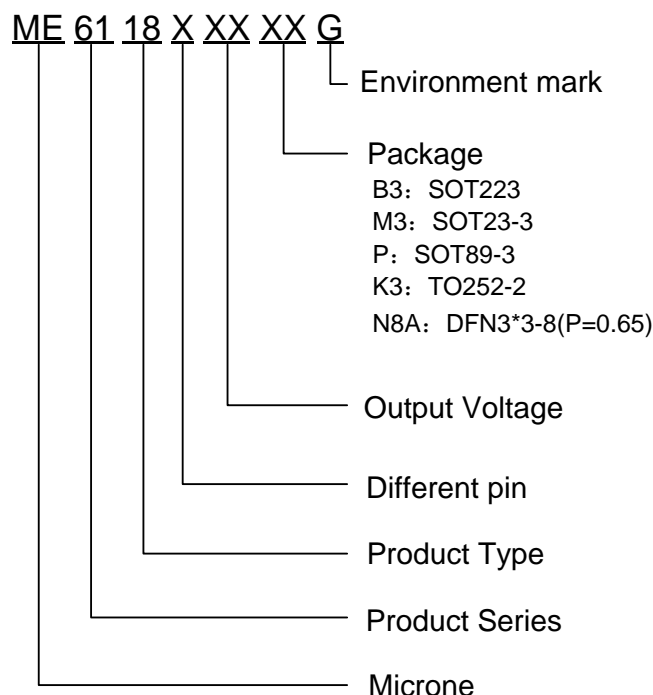

product series	product description
ME6118A12B3G	V _{OUT} =1.2V; Package: SOT223
ME6118A18B3G	V _{OUT} =1.8V; Package: SOT223
ME6118A18N8AG	V _{OUT} =1.8V; Package: DFN3*3-8 (P=0.65)
ME6118A25B3G	V _{OUT} =2.5V; Package: SOT223
ME6118A33B3G	V _{OUT} =3.3V; Package: SOT223
ME6118A33PG	V _{OUT} =3.3V; Package: SOT89-3
ME6118A33M3G	V _{OUT} =3.3V; Package: SOT23-3
ME6118A33K3G	V _{OUT} =3.3V; Package: TO252-2
ME6118A36PG	V _{OUT} =3.6V; Package: SOT89-3
ME6118A43B3G	V _{OUT} =4.3V; Package: SOT223
ME6118A50B3G	V _{OUT} =5.0V; Package: SOT223
ME6118A50PG	V _{OUT} =5.0V; Package: SOT89-3
ME6118B075N8AG	V _{OUT} =0.75V; Package: DFN3*3-8 (P=0.65); Different pin
ME6118E25B3G	V _{OUT} =2.5V; Package: SOT223; Different pin
ME6118E33B3G	V _{OUT} =3.3V; Package: SOT223; Different pin
ME6118H33B3G	V _{OUT} =3.3V; Package: SOT223; Different pin
ME6118H33PG	V _{OUT} =3.3V; Package: SOT89-3; Different pin
ME6118L50K3G	V _{OUT} =5.0V; Package: TO252-2; Different pin

NOTE: At present ,there are eight kinds of voltage value: 0.75V、1.2V、1.8V、2.5V、3.3V、3.6V、4.3V、5.0V。

If you need other voltage and package, please contact our sales staff.

Pin Configuration

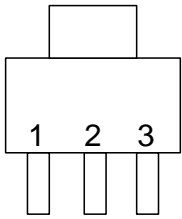

SOT223

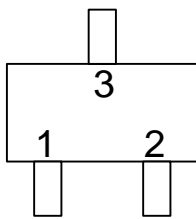

SOT23-3

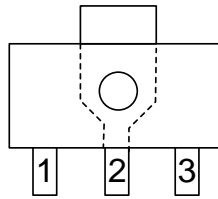

SOT89-3

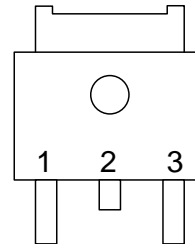

TO252-2

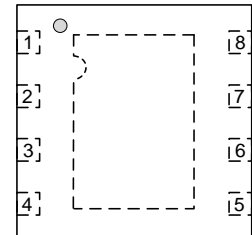

DFN3*3-8

Pin Assignment

ME6118AXX

Pin Number					Pin Name	Functions
SOT223	SOT89-3	TO252-2	SOT23-3	DFN3*3-8		
1	1	1	1	7	GND	Ground
2	3	2	2	3,4	V _{OUT}	Output
3	2	3	3	1,2	V _{IN}	Power Input
				5,6,8	NC	

ME6118BXX

Pin Number	Pin Name	Functions
DFN3*3-8		
4	GND	Ground
1	V _{OUT}	Output
8	V _{IN}	Power Input
2,3,5,6,7	NC	

ME6118EXX

Pin Number		Pin Name	Functions
SOT223	TO252-2		
1	1	GND	Ground
2	2	V _{IN}	Power Input
3	3	V _{OUT}	Output

ME6118HXX

Pin Number			Pin Name	Functions
SOT223	TO252-2	SOT89-3		
1	1	1	V _{OUT}	Output
2	2	2	GND	Ground
3	3	3	V _{IN}	Power Input

ME6118LXX

Pin Number		Pin Name	Functions
SOT223	TO252-2		
1	1	V _{IN}	Power Input
2	2	GND	Ground
3	3	V _{OUT}	Output

Block Diagram

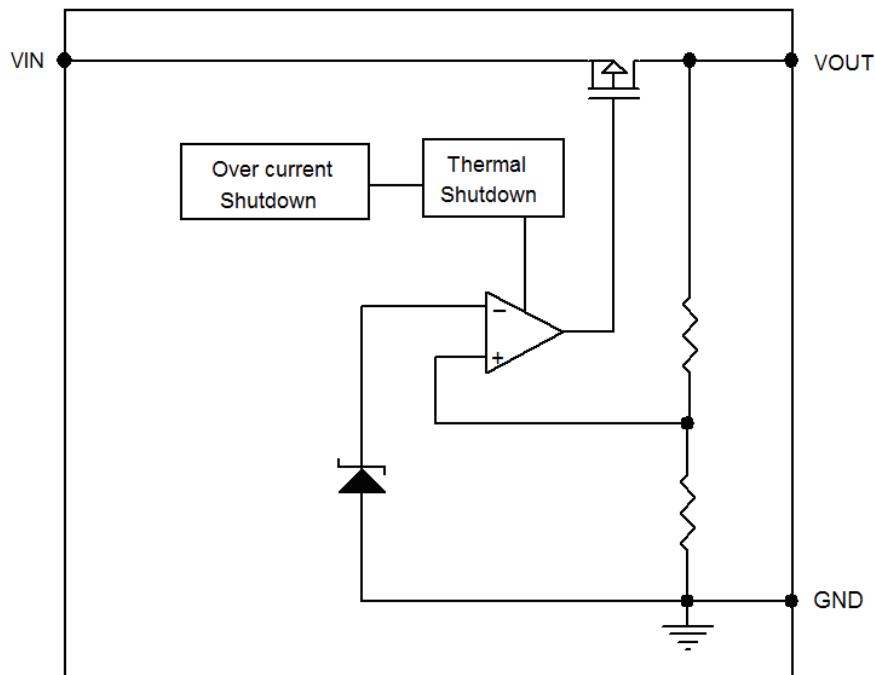

Absolute Maximum Ratings

Parameter	Symbol	Ratings	Units	
Input Voltage	V_{IN}	18	V	
Output Current	I_{OUT}	1.1	A	
Output Voltage	V_{OUT}	$V_{SS}-0.3 \sim V_{IN}+0.3$	V	
Thermal resistance	θ_{ja}	SOT223	70	$^{\circ}\text{C}/\text{W}$
		SOT89-3	100	
		TO252-2	55	
		SOT23-3	230	
		DFN3*3-8	70	
Power Dissipation	P_D	SOT223	1.8	W
		SOT89-3	1.25	
		TO252-2	2.25	
		SOT23-3	0.54	
		DFN3*3-8	1.8	
Operating Ambient Temperature Range	T_{OPR}	-40 ~ +85	$^{\circ}\text{C}$	
Storage Temperature Range	T_{STG}	-55 ~ +150	$^{\circ}\text{C}$	
Junction temperature Range	T_J	-40 ~ +150	$^{\circ}\text{C}$	
Lead Temperature		260 $^{\circ}\text{C}$, 4sec		

Electrical Characteristics

ME6118B075 (Package:DFN3*3-8)

($V_{IN} = V_{OUT} + 1.0V$, $C_{IN} = C_L = 10\mu F$, $T_a = 25^\circ C$, unless otherwise noted)

Parameter	Symbol	Conditions	Min.	Typ.	Max.	Units
Output Voltage	$V_{OUT}(E)$ (Note 2)	$I_{OUT} = 10mA$, $V_{IN} = V_{OUT} + 1.0V$	X 0.98	$V_{OUT}(T)$ (Note 1)	X 1.02	V
Maximum Output Current	I_{OUTMAX}	$V_{IN} = V_{OUT} + 1.0V$		400		mA
Load Regulation	ΔV_{OUT}	$V_{IN} = V_{OUT} + 1.0V$, $1mA \leq I_{OUT} \leq 400mA$		3		mV
Dropout Voltage (Note 3)	V_{DIF}	$I_{OUT} = 400mA$		1000		mV
Quiescent Current	I_{SS}	$V_{IN} = V_{OUT} + 1.3V$		46		μA
Line Regulation	ΔV_{OUT}	$I_{OUT} = 0mA$ $V_{OUT} + 1.0V \leq V_{IN} \leq 8V$		1		mV
Thermal Shutdown Protection	T_{sd}	$I_{OUT} = 10mA$, $V_{IN} = V_{OUT} + 1.3V$		160		$^\circ C$
Over Current Protection	I_{limit}	$V_{IN} = 3V$		1.1		A

ME6118A12/E12/H12/L12 (Packages:SOT223 , SOT89-3, TO252-2)

($V_{IN} = V_{OUT} + 1.3V$, $C_{IN} = C_L = 10\mu F$, $T_a = 25^\circ C$, unless otherwise noted)

Parameter	Symbol	Conditions	Min.	Typ.	Max.	Units
Output Voltage	$V_{OUT}(E)$ (Note 2)	$I_{OUT} = 10mA$, $V_{IN} = V_{OUT} + 1.3V$	X 0.98	$V_{OUT}(T)$ (Note 1)	X 1.02	V
Maximum Output Current	I_{OUTMAX}	$V_{IN} = V_{OUT} + 1.3V$		800		mA
Load Regulation	ΔV_{OUT}	$V_{IN} = V_{OUT} + 1.3V$, $1mA \leq I_{OUT} \leq 800mA$		3		mV
Dropout Voltage (Note 3)	V_{DIF1}	$I_{OUT} = 100mA$		195		mV
	V_{DIF2}	$I_{OUT} = 400mA$		665		mV
	V_{DIF3}	$I_{OUT} = 800mA$		1250		mV
	V_{DIF4}	$I_{OUT} = 1000mA$		1600		mV
Quiescent Current	I_{SS}	$V_{IN} = V_{OUT} + 1.3V$		53		μA
Line Regulation	ΔV_{OUT}	$I_{OUT} = 0mA$ $V_{OUT} + 1.3V \leq V_{IN} \leq 18V$		2		mV
Thermal Shutdown Protection	T_{sd}	$I_{OUT} = 10mA$, $V_{IN} = V_{OUT} + 1.3V$		155		$^\circ C$
Over Current Protection	I_{limit}	$V_{IN} = 3V$		1.1		A

ME6118A18/E18/H18/L18 (Packages:SOT223 , SOT89-3, TO252-2, DFN3*3-8)

 $(V_{IN} = V_{OUT} + 1.2V, C_{IN} = C_L = 10\mu F, T_a = 25^\circ C, \text{ unless otherwise noted})$

Parameter	Symbol	Conditions	Min.	Typ.	Max.	Units
Output Voltage	$V_{OUT(E)}$ (Note 2)	$I_{OUT} = 10mA$ $V_{IN} = V_{OUT} + 1.2V$	X 0.98	$V_{OUT(T)}$ (Note 1)	X 1.02	V
Maximum Output Current	I_{OUTMAX}	$V_{IN} = V_{OUT} + 1.2V$		800		mA
Load Regulation	ΔV_{OUT}	$V_{IN} = V_{OUT} + 1.2V$, $1mA \leq I_{OUT} \leq 800mA$		5		mV
Dropout Voltage (Note 3)	V_{DIF1}	$I_{OUT} = 100mA$		115		mV
	V_{DIF2}	$I_{OUT} = 400mA$		450		mV
	V_{DIF3}	$I_{OUT} = 800mA$		940		mV
	V_{DIF4}	$I_{OUT} = 1000mA$		1600		mV
Quiescent Current	I_{SS}	$V_{IN} = V_{OUT} + 1.2V$		52		uA
Line Regulation	ΔV_{OUT}	$I_{OUT} = 0mA$ $V_{OUT} + 1.2V \leq V_{IN} \leq 18V$		2		mV
Thermal Shutdown Protection	T_{SD}	$I_{OUT} = 10mA$ $V_{IN} = V_{OUT} + 1.2V$		160		°C
Over Current Protection	I_{LIMIT}	$V_{IN} = 3.5V$		1.1		A

ME6118A25/E25/H25/L25 (Packages:SOT223 , SOT89-3, TO252-2)

 $(V_{IN} = V_{OUT} + 1.2V, C_{IN} = C_L = 10\mu F, T_a = 25^\circ C, \text{ unless otherwise noted})$

Parameter	Symbol	Conditions	Min.	Typ.	Max.	Units
Output Voltage	$V_{OUT(E)}$ (Note 2)	$I_{OUT} = 10mA$, $V_{IN} = V_{OUT} + 1.2V$	X 0.98	$V_{OUT(T)}$ (Note 1)	X 1.02	V
Maximum Output Current	I_{OUTMAX}	$V_{IN} = V_{OUT} + 1.2V$		800		mA
Load Regulation	ΔV_{OUT}	$V_{IN} = V_{OUT} + 1.2V$, $1mA \leq I_{OUT} \leq 800mA$		5		mV
Dropout Voltage (Note 3)	V_{DIF1}	$I_{OUT} = 100mA$		90		mV
	V_{DIF2}	$I_{OUT} = 500mA$		450		mV
	V_{DIF3}	$I_{OUT} = 800mA$		790		mV
	V_{DIF4}	$I_{OUT} = 1000mA$		1300		mV
Quiescent Current	I_{SS}	$V_{IN} = V_{OUT} + 1.2V$		53		uA
Line Regulation	ΔV_{OUT}	$I_{OUT} = 0mA$ $V_{OUT} + 1.2V \leq V_{IN} \leq 18V$		2		mV
Thermal Shutdown Protection	T_{SD}	$I_{OUT} = 10mA$, $V_{IN} = V_{OUT} + 1.2V$		160		°C
Over Current Protection	I_{LIMIT}	$V_{IN} = 4.0V$		1.1		A

ME6118A33/E33/H33/L33 (Packages:SOT223 , SOT89-3, TO252-2)

($V_{IN} = V_{OUT} + 1.2V$, $C_{IN} = C_L = 10\mu F$, $T_a = 25^\circ C$, unless otherwise noted)

Parameter	Symbol	Conditions	Min.	Typ.	Max.	Units
Output Voltage	$V_{OUT(E)}$ (Note 2)	$I_{OUT} = 10mA$, $V_{IN} = V_{OUT} + 1.2V$	X 0.98	$V_{OUT(T)}$ (Note 1)	X 1.02	V
Maximum Output Current	I_{OUTMAX}	$V_{IN} = V_{OUT} + 1.2V$		800		mA
Load Regulation	ΔV_{OUT}	$V_{IN} = V_{OUT} + 1.2V$, $1mA \leq I_{OUT} \leq 800mA$		7		mV
Dropout Voltage (Note 3)	V_{DIF1}	$I_{OUT} = 100mA$		80		mV
	V_{DIF2}	$I_{OUT} = 500mA$		400		mV
	V_{DIF3}	$I_{OUT} = 800mA$		680		mV
	V_{DIF4}	$I_{OUT} = 1000mA$		1300		mV
Quiescent Current	I_{SS}	$V_{IN} = V_{OUT} + 1.2V$		53		uA
Line Regulation	ΔV_{OUT}	$I_{OUT} = 0mA$ $V_{OUT} + 1.2V \leq V_{IN} \leq 18V$		2		mV
Thermal Shutdown Protection	T_{sd}	$I_{OUT} = 10mA$, $V_{IN} = V_{OUT} + 1.2V$		160		$^\circ C$
Over Current Protection	I_{limit}	$V_{IN} = 5.0V$		1.1		A

ME6118A33 (Package: SOT23-3)

($V_{IN} = V_{OUT} + 1.2V$, $C_{IN} = C_L = 10\mu F$, $T_a = 25^\circ C$, unless otherwise noted)

Parameter	Symbol	Conditions	Min.	Typ.	Max.	Units
Output Voltage	$V_{OUT(E)}$ (Note 2)	$I_{OUT} = 10mA$, $V_{IN} = V_{OUT} + 1.2V$	X 0.98	$V_{OUT(T)}$ (Note 1)	X 1.02	V
Maximum Output Current	I_{OUTMAX}	$V_{IN} = V_{OUT} + 1.2V$		500		mA
Load Regulation	ΔV_{OUT}	$V_{IN} = V_{OUT} + 1.2V$, $1mA \leq I_{OUT} \leq 500mA$		10		mV
Dropout Voltage (Note 3)	V_{DIF1}	$I_{OUT} = 100mA$		70		mV
	V_{DIF2}	$I_{OUT} = 300mA$		220		mV
	V_{DIF3}	$I_{OUT} = 500mA$		385		mV
Quiescent Current	I_{SS}	$V_{IN} = V_{OUT} + 1.2V$		53		uA
Line Regulation	ΔV_{OUT}	$I_{OUT} = 0mA$ $V_{OUT} + 1.2V \leq V_{IN} \leq 18V$		2		mV
Thermal Shutdown Protection	T_{sd}	$I_{OUT} = 10mA$, $V_{IN} = V_{OUT} + 1.2V$		160		$^\circ C$
Over Current Protection	I_{limit}	$V_{IN} = 5.0V$		1.1		A

ME6118A36 (Packages: SOT89-3)

($V_{IN} = V_{OUT} + 1.2V$, $C_{IN} = C_L = 10\mu F$, $T_a = 25^\circ C$, unless otherwise noted)

Parameter	Symbol	Conditions	Min.	Typ.	Max.	Units
Output Voltage	$V_{OUT(E)}$ (Note 2)	$I_{OUT} = 10mA$, $V_{IN} = V_{OUT} + 1.2V$	X 0.98	$V_{OUT(T)}$ (Note 1)	X 1.02	V
Maximum Output Current	I_{OUTMAX}	$V_{IN} = V_{OUT} + 1.2V$		800		mA
Load Regulation	ΔV_{OUT}	$V_{IN} = V_{OUT} + 1.2V$, $1mA \leq I_{OUT} \leq 800mA$		7		mV
Dropout Voltage (Note 3)	V_{DIF1}	$I_{OUT} = 100mA$		80		mV
	V_{DIF2}	$I_{OUT} = 500mA$		380		mV
	V_{DIF3}	$I_{OUT} = 800mA$		660		mV
	V_{DIF4}	$I_{OUT} = 1000mA$		900		mV
Quiescent Current	I_{SS}	$V_{IN} = V_{OUT} + 1.2V$		53		μA
Line Regulation	ΔV_{OUT}	$I_{OUT} = 0mA$ $V_{OUT} + 1.2V \leq V_{IN} \leq 18V$		2		mV
Thermal Shutdown Protection	T_{SD}	$I_{OUT} = 10mA$, $V_{IN} = V_{OUT} + 1.2V$		160		$^\circ C$
Over Current Protection	I_{LIMIT}	$V_{IN} = 5.0V$		1.1		A

ME6118A43 (Packages: SOT223, SOT89-3, TO252-2)

($V_{IN} = V_{OUT} + 1.2V$, $C_{IN} = C_L = 10\mu F$, $T_a = 25^\circ C$, unless otherwise noted)

Parameter	Symbol	Conditions	Min.	Typ.	Max.	Units
Output Voltage	$V_{OUT(E)}$ (Note 2)	$I_{OUT} = 10mA$, $V_{IN} = V_{OUT} + 1.2V$	X 0.98	$V_{OUT(T)}$ (Note 1)	X 1.02	V
Maximum Output Current	I_{OUTMAX}	$V_{IN} = V_{OUT} + 1.2V$		800		mA
Load Regulation	ΔV_{OUT}	$V_{IN} = V_{OUT} + 1.2V$, $1mA \leq I_{OUT} \leq 800mA$		7		mV
Dropout Voltage (Note 3)	V_{DIF1}	$I_{OUT} = 100mA$		80		mV
	V_{DIF2}	$I_{OUT} = 500mA$		350		mV
	V_{DIF3}	$I_{OUT} = 800mA$		600		mV
	V_{DIF4}	$I_{OUT} = 1000mA$		900		mV
Quiescent Current	I_{SS}	$V_{IN} = V_{OUT} + 1.2V$		53		μA
Line Regulation	ΔV_{OUT}	$I_{OUT} = 0mA$ $V_{OUT} + 1.2V \leq V_{IN} \leq 18V$		2		mV
Thermal Shutdown Protection	T_{SD}	$I_{OUT} = 10mA$, $V_{IN} = V_{OUT} + 1.2V$		160		$^\circ C$
Over Current Protection	I_{LIMIT}	$V_{IN} = 5.8V$		1.1		A

ME6118A50/E50/H50/L50 (Packages:SOT223 , SOT89-3, TO252-2)

($V_{IN} = V_{OUT} + 1.2V$, $C_{IN} = C_L = 10\mu F$, $T_a = 25^\circ C$, unless otherwise noted)

Parameter	Symbol	Conditions	Min.	Typ.	Max.	Units
Output Voltage	$V_{OUT}(E)$ (Note 2)	$I_{OUT} = 10mA$, $V_{IN} = V_{OUT} + 1.2V$	X 0.98	$V_{OUT}(T)$ (Note 1)	X 1.02	V
Maximum Output Current	I_{OUTMAX}	$V_{IN} = V_{OUT} + 1.2V$		800		mA
Load Regulation	ΔV_{OUT}	$V_{IN} = V_{OUT} + 1.2V$, $1mA \leq I_{OUT} \leq 800mA$		8		mV
Dropout Voltage (Note 3)	V_{DIF1}	$I_{OUT} = 100mA$		60		mV
	V_{DIF2}	$I_{OUT} = 500mA$		300		mV
	V_{DIF3}	$I_{OUT} = 800mA$		500		mV
	V_{DIF4}	$I_{OUT} = 1000mA$		900		mV
Quiescent Current	I_{SS}	$V_{IN} = V_{OUT} + 1.2V$		53		μA
Line Regulation	ΔV_{OUT}	$I_{OUT} = 0mA$ $V_{OUT} + 1.2V \leq V_{IN} \leq 18V$		2		mV
Thermal Shutdown Protection	T_{SD}	$I_{OUT} = 10mA$, $V_{IN} = V_{OUT} + 1.2V$		160		$^\circ C$
Over Current Protection	I_{LIMIT}	$V_{IN} = 6.5V$		1.1		A

Note :

- $V_{OUT}(T)$: Specified Output Voltage
- $V_{OUT}(E)$: Effective Output Voltage (ie. The output voltage when " $V_{OUT}(T) + 1.2V$ " is provided at the V_{IN} pin while maintaining a certain I_{OUT} value.)
- V_{DIF} : $V_{IN1} - V_{OUT}(E)$
 V_{IN1} : The input voltage when $V_{OUT}(E)$ appears as input voltage is gradually decreased.
 $V_{OUT}(E)$ = A voltage equal to 98% of the output voltage whenever an amply stabilized I_{OUT} and $\{V_{OUT}(T) + 1.2V\}$ is input.

Type Characteristics

(1) Output Voltage VS. Output Current

ME6118A12B3G ($V_{IN}=V_{OUT}+1.3V$)

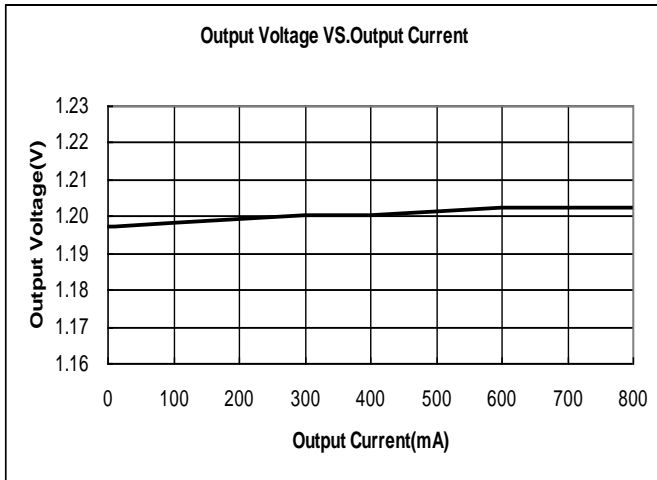

ME6118A18B3G ($V_{IN}=V_{OUT}+1.2V$)

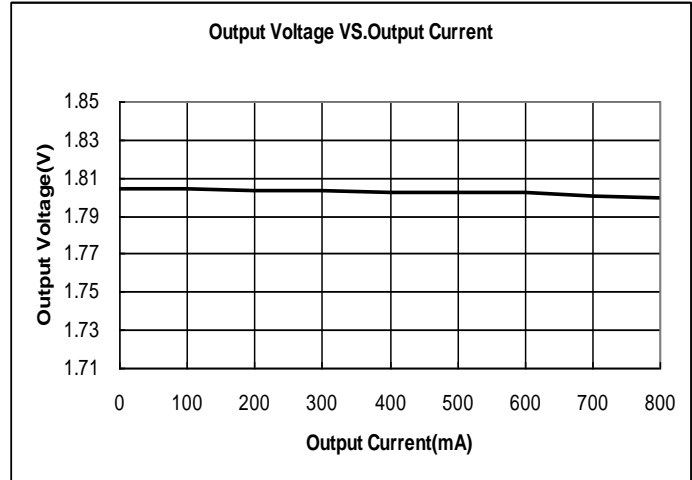

ME6118A25B3G ($V_{IN}=V_{OUT}+1.2V$)

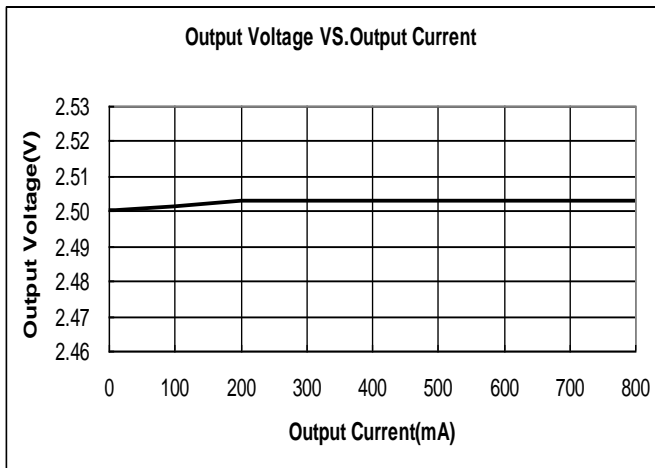

ME6118A33B3G ($V_{IN}=V_{OUT}+1.2V$)

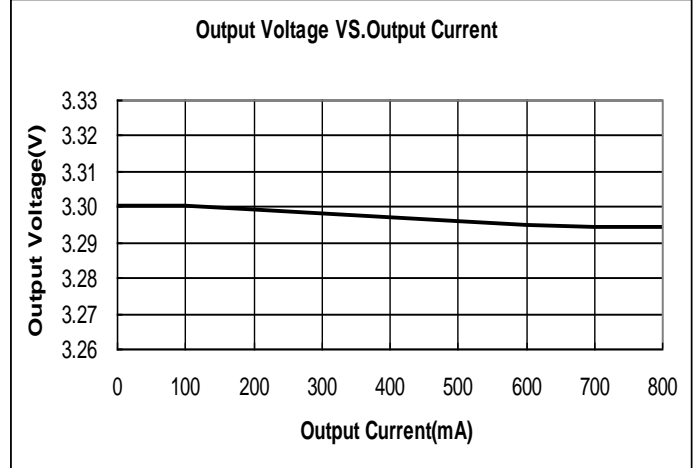

ME6118B075N8AG ($V_{IN}=V_{OUT}+1.0V$)

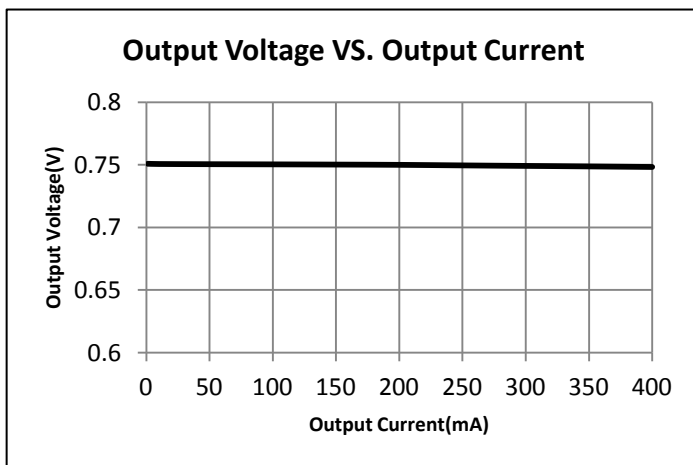

(2) Output Voltage VS. Temperature

ME6118A12B3G ($V_{IN}=V_{OUT}+1.3V$, $I_{OUT}=10mA$)

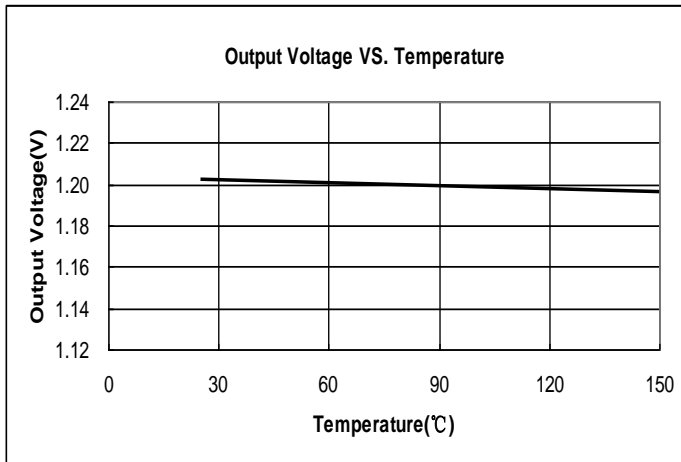

ME6118A18B3G ($V_{IN}=V_{OUT}+1.2V$, $I_{OUT}=10mA$)

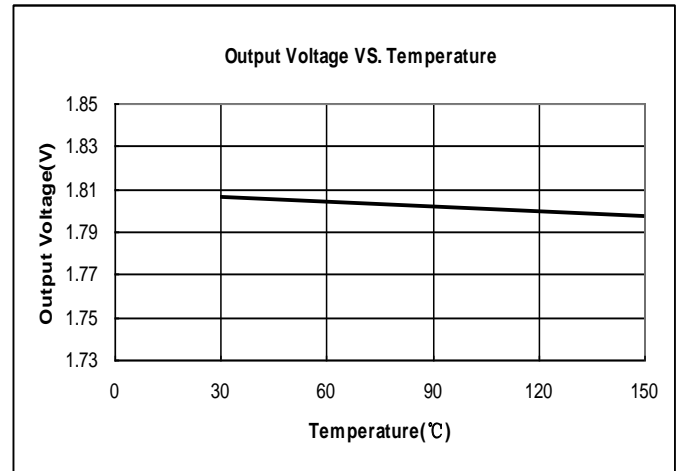

ME6118A25B3G ($V_{IN}=V_{OUT}+1.2V$, $I_{OUT}=10mA$)

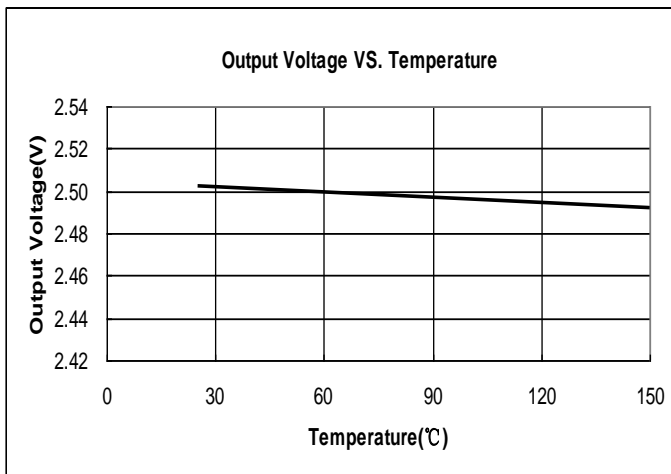

ME6118A33B3G ($V_{IN}=V_{OUT}+1.2V$, $I_{OUT}=10mA$)

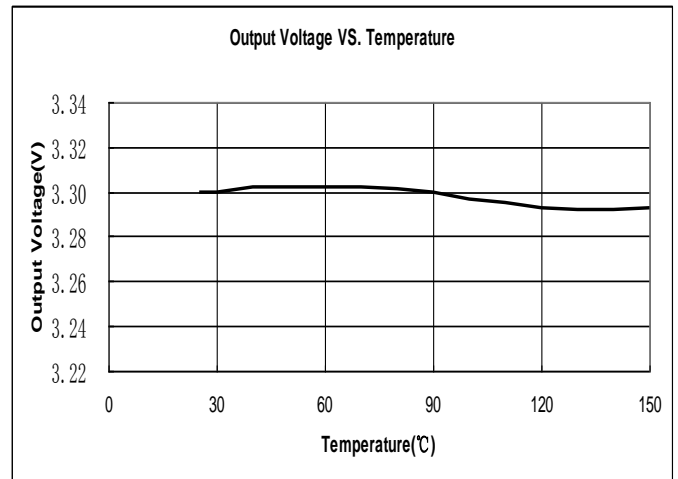

ME6118B075N8AG ($V_{IN}=V_{OUT}+1.0V$, $I_{OUT}=10mA$)

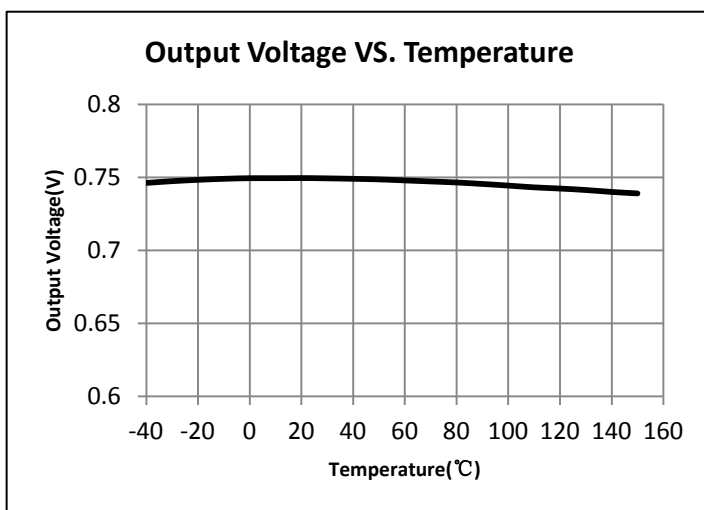

(3) Dropout Voltage VS. Output Current (Ta = 25 °C)

ME6118A12B3G

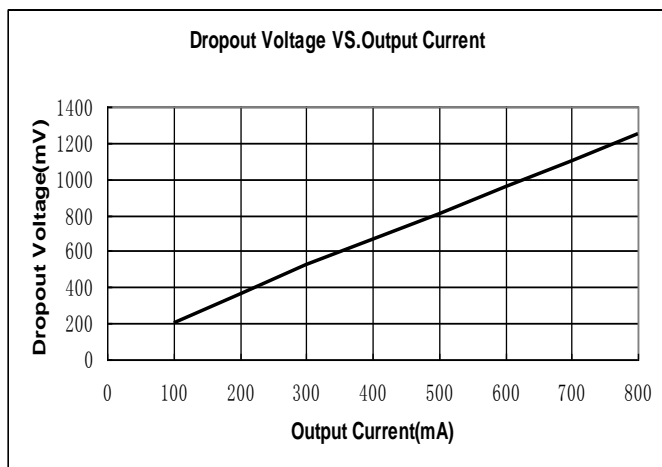

ME6118A18B3G

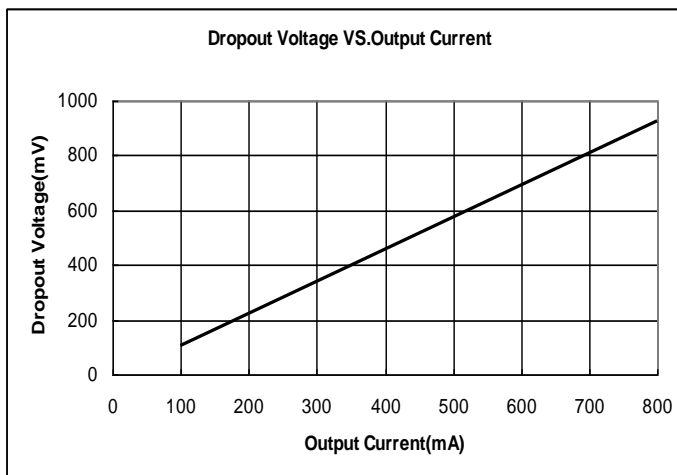

ME6118A25B3G

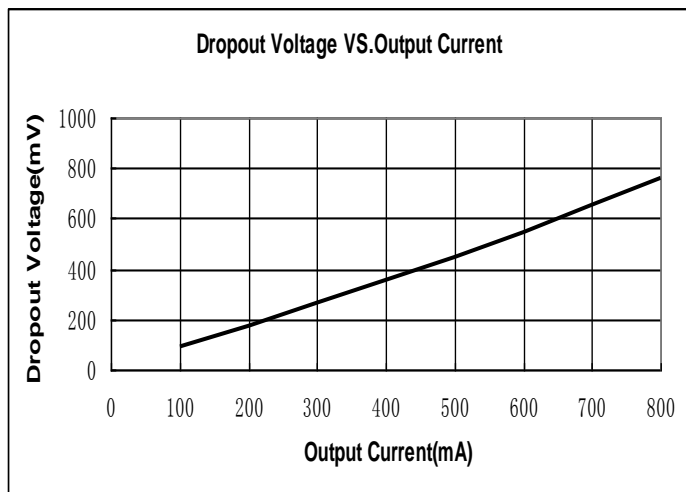

ME6118A33B3G

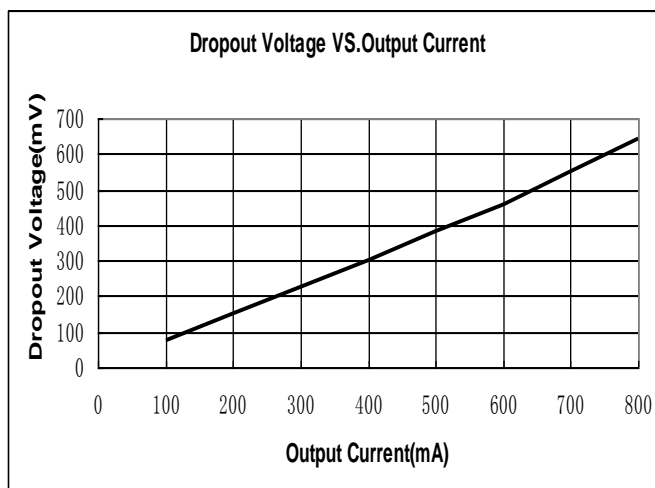

(4) Output Voltage VS. Input Voltage (Ta = 25 °C)

ME6118A12B3G

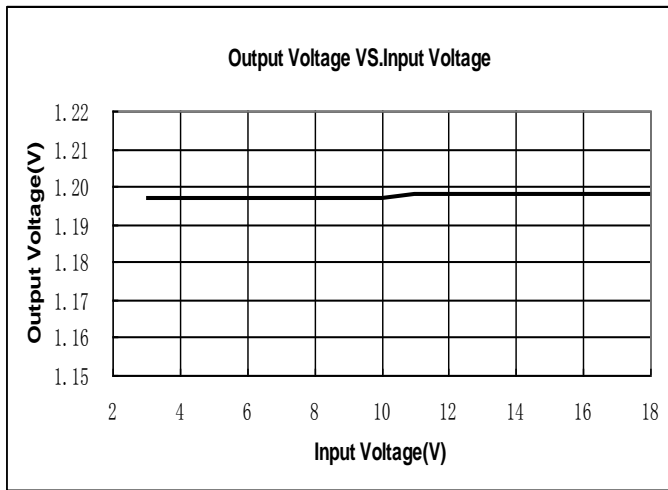

ME6118A18B3G

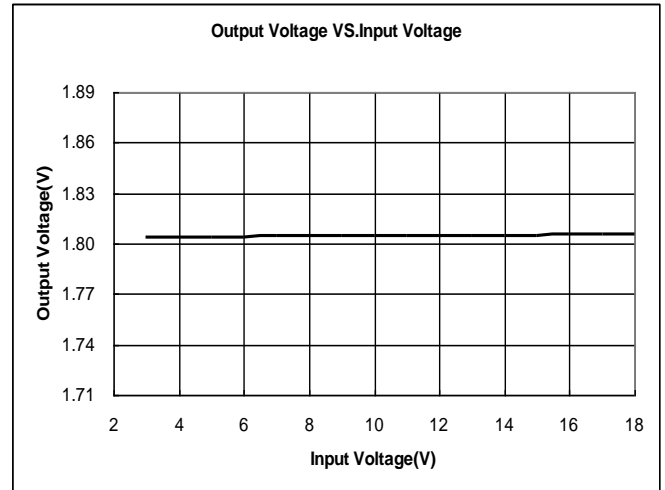

ME6118A25B3G

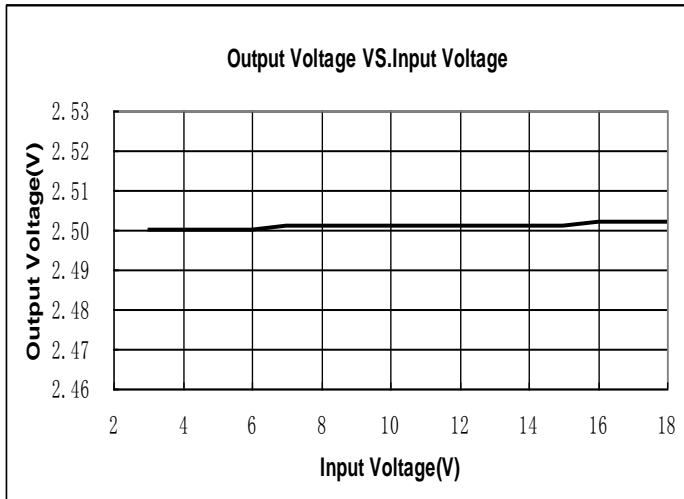

ME6118A33B3G

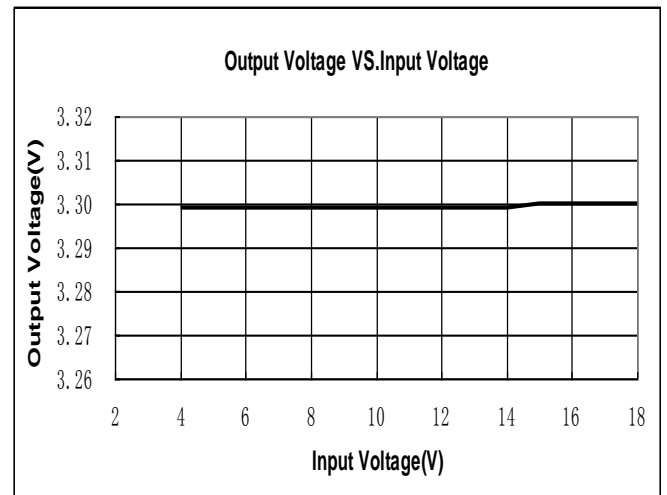

ME6118B075N8AG (VIN=VOUT+1.0V, IOUT=10mA)

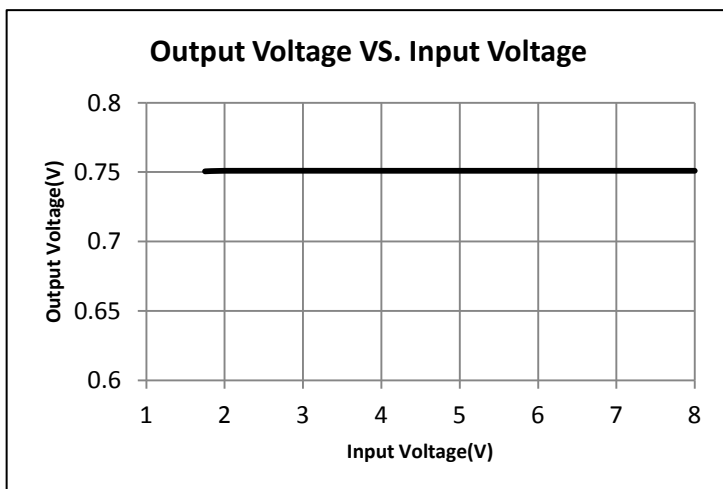

(5) Quiescent Current VS. Input Voltage

ME6118A12B3G

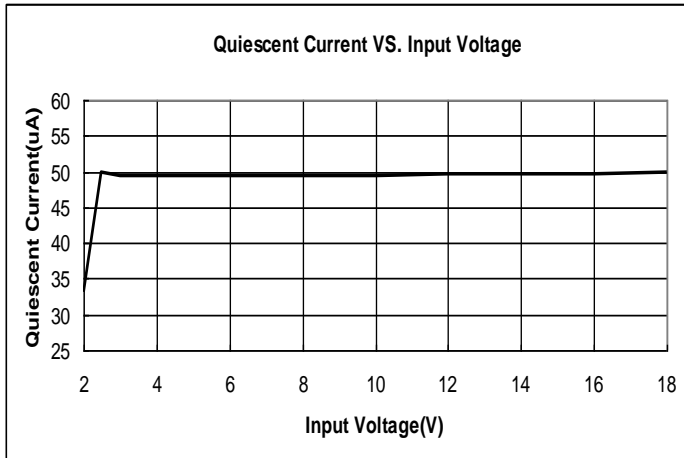

ME6118A18B3G

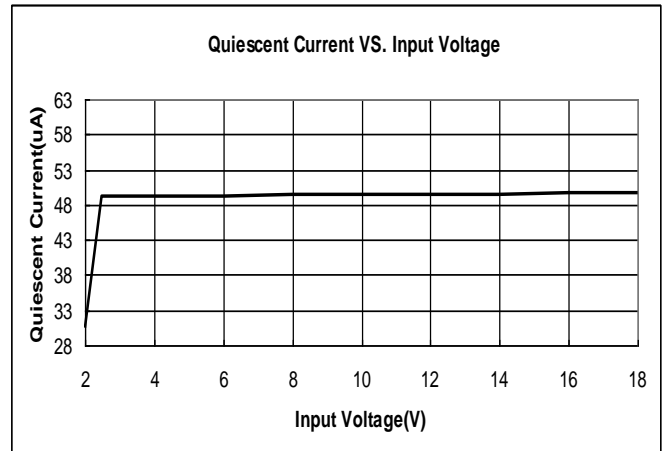

ME6118A25B3G

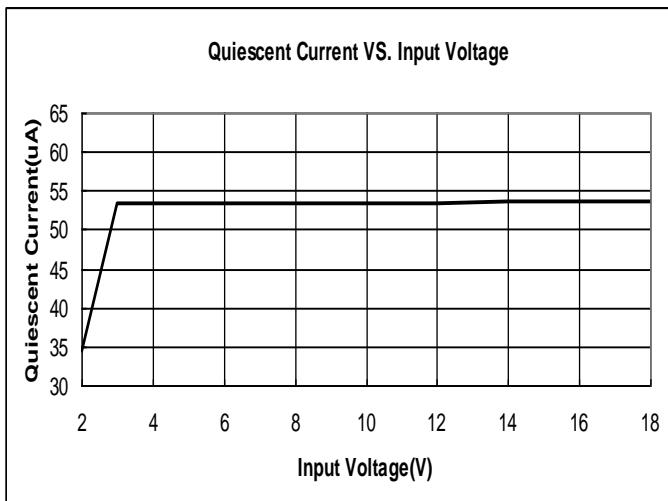

ME6118A33B3G

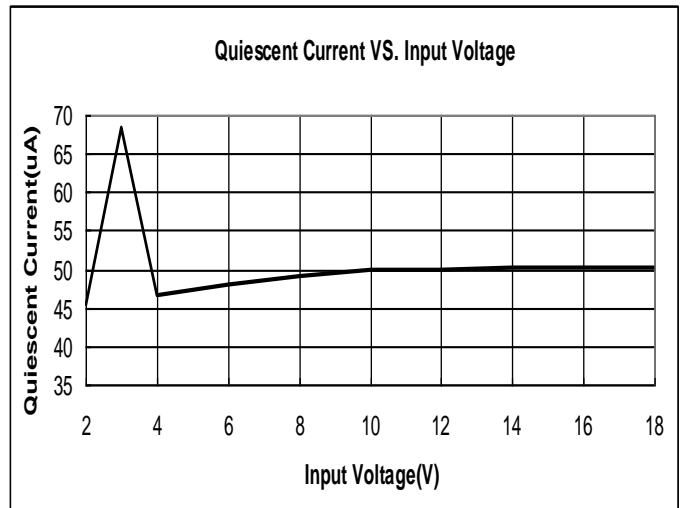

ME6118B075N8AG

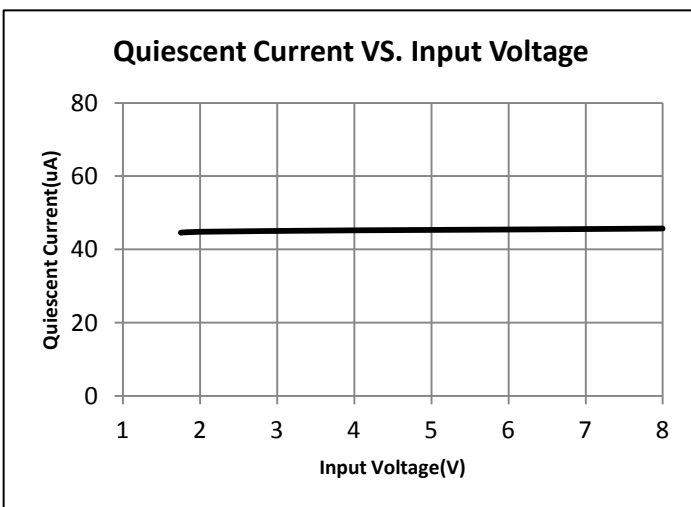

Applications Information

1. Input Bypass Capacitor

An input capacitor is recommended. A 10uF tantalum on the input is a suitable input bypassing for almost all applications.

2. Output Capacitor

The output capacitor is critical in maintaining regulator stability, and must meet the required conditions for both minimum amount of capacitance and ESR (Equivalent Series Resistance). The minimum output capacitance required by the ME6118 is 10μF, if a tantalum capacitor is used. Any increase of the output capacitance will merely improve the loop stability and transient response. The ESR of the output capacitor should be less than 0.5Ω.

3. Load Regulation

The ME6118 regulates the voltage that appears between its output and ground pins. In some cases, line resistances can introduce errors to the voltage across the load. To obtain the best load regulation, a few precautions are needed. Figure1, shows a typical application using a fixed output regulator. The R_{t1} and R_{t2} are the line resistances. It is obvious that the V_{LOAD} is less than the V_{OUT} by the sum of the voltage drops along the line resistances. In this case, the load regulation seen at the R_{LOAD} would be degraded from the datasheet specification. To improve this, the load should be tied directly to the output terminal on the positive side and directly tied to the ground terminal on the negative side.

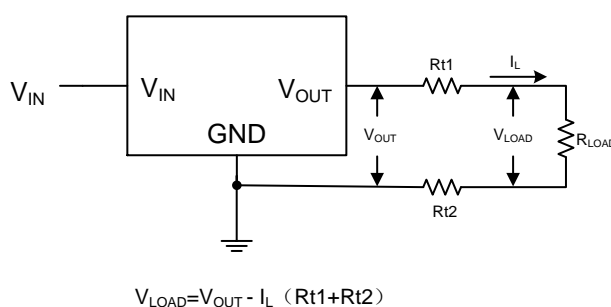

$$V_{LOAD} = V_{OUT} - I_L (R_{t1} + R_{t2})$$

FIGURE 1. Typical Application using Fixed Output Regulator

Application Circuit

(1) Regulator with Reference

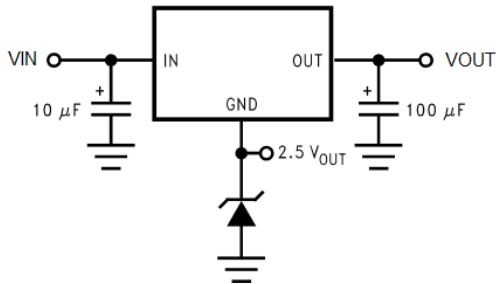

(2) Adjusting Output of Fixed Voltage Regulators

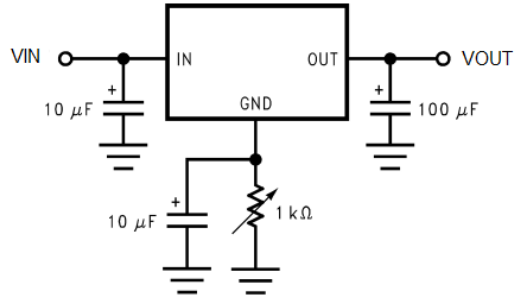

(3) Battery Backed-Up Power Supply

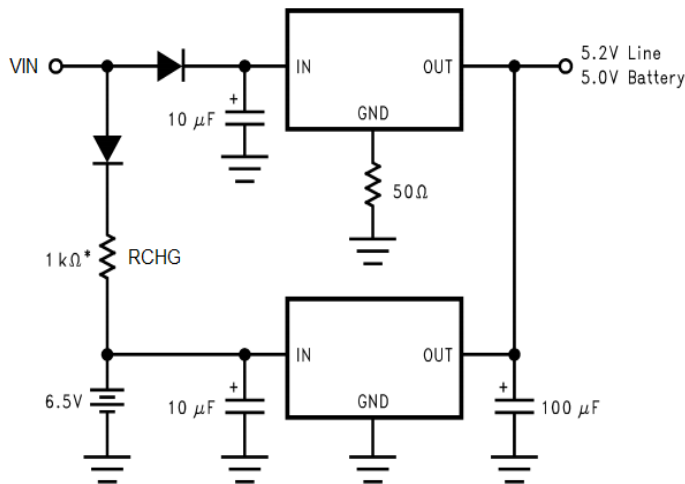

* Select for charge rate.

(4) Low Dropout Negative Supply

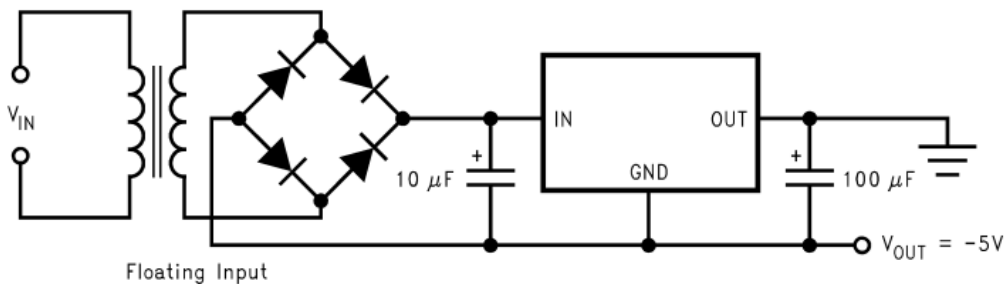

Packaging Information

- SOT223

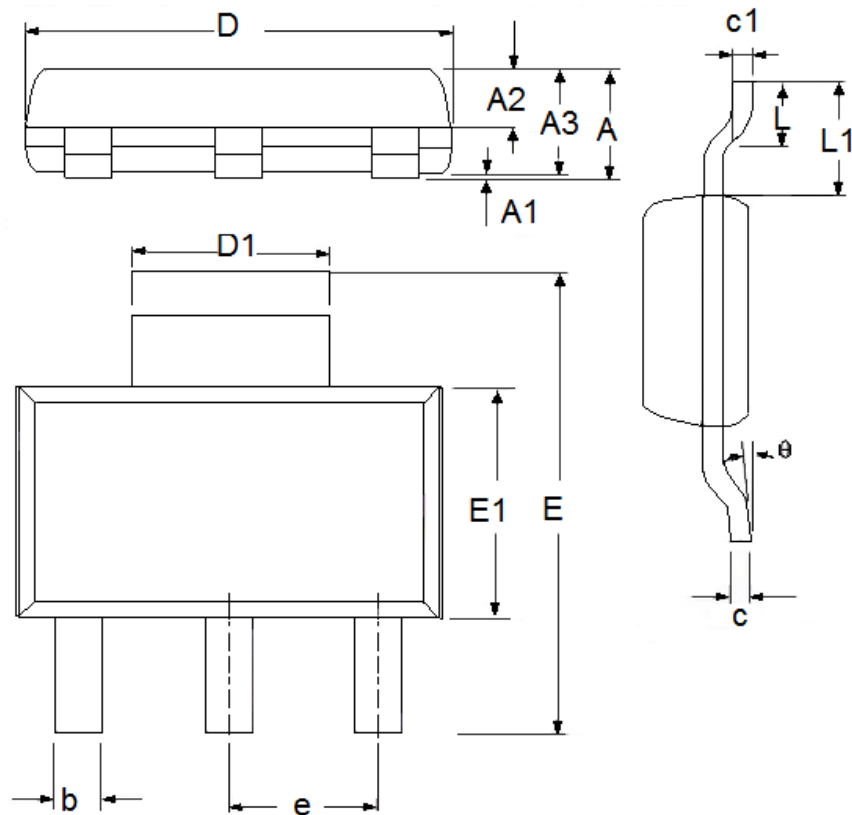

DIM	Millimeters		Inches	
	Min	Max	Min	Max
A	1.48	1.8	0.0583	0.0709
A1	0	0.15	0.0000	0.0059
A2	0.6	0.95	0.0236	0.0374
A3	1.45	1.75	0.0571	0.0689
b	0.6	0.82	0.0236	0.0323
c	0.2	0.35	0.0079	0.0138
D	6.2	6.6	0.2441	0.2598
D1	2.9	3.1	0.1142	0.1220
E	6.7	7.3	0.2638	0.2784
E1	3.3	3.7	0.1299	0.1457
e	2.3(TYP)		0.0906(TYP)	
L	0.76	1.16	0.0299	0.0457
L1	1.75(TYP)		0.0689(TYP)	
θ	0	10°	0.0000	10°
c1	0.25(TYP)		0.0098(TYP)	

● SOT23-3

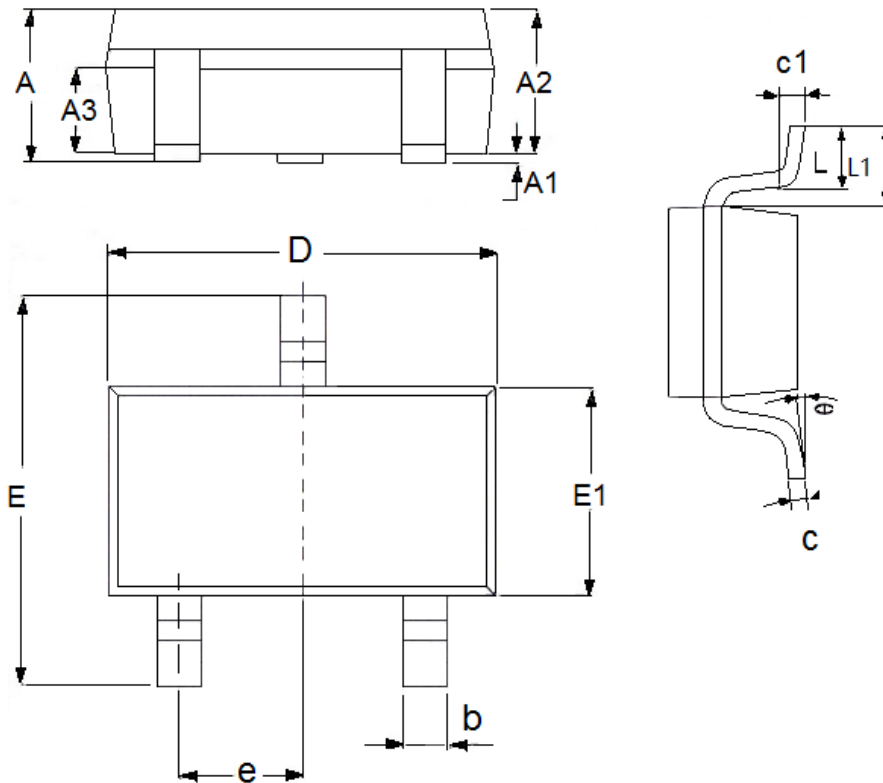

DIM	Millimeters		Inches	
	Min	Max	Min	Max
A	1.05	1.45	0.0413	0.0571
A1	0	0.15	0.0000	0.0059
A2	0.9	1.3	0.0354	0.0512
A3	0.6	0.7	0.0236	0.0276
b	0.25	0.5	0.0098	0.0197
c	0.1	0.25	0.0039	0.0098
D	2.8	3.1	0.1102	0.1220
E	2.6	3.1	0.1023	0.1220
E1	1.5	1.8	0.0591	0.0709
e	0.95(TYP)		0.0374(TYP)	
L	0.25	0.6	0.0098	0.0236
L1	0.59(TYP)		0.0232(TYP)	
θ	0	8°	0.0000	8°
c1	0.2(TYP)		0.0079(TYP)	

● TO252-2

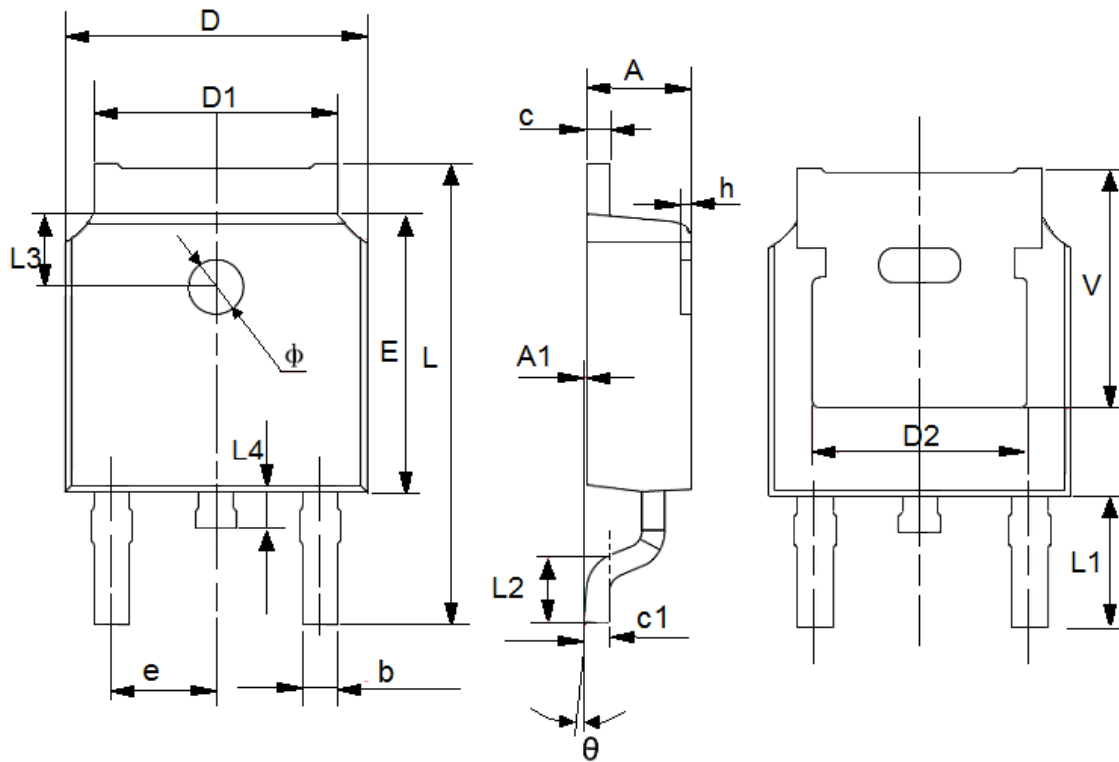

DIM	Millimeters		Inches	
	Min	Max	Min	Max
A	2.2	2.4	0.0866	0.0945
A1	0	0.127	0	0.005
b	0.66	0.86	0.026	0.0339
c	0.46	0.58	0.0181	0.0228
c1	0.498	0.6	0.0196	0.0236
D	6.5	6.7	0.2559	0.2638
D1	5.33(TYP)		0.2098(TYP)	
D2	4.83(TYP)		0.1902(TYP)	
E	6	6.2	0.2362	0.2441
e	2.286(TYP)		0.09(TYP)	
L	9.8	10.4	0.3858	0.4094
L1	2.9(TYP)		0.1142(TYP)	
L2	1.4	1.7	0.0551	0.0669
L3	1.8(TYP)		0.07(TYP)	
L4	0.6	1	0.0236	0.0394
h	0	0.3	0	0.0118
Φ	1.1	1.3	0.0433	0.0512
V	5.3(TYP)		0.2087(TYP)	
θ	0	8°	0	8°

● SOT89-3

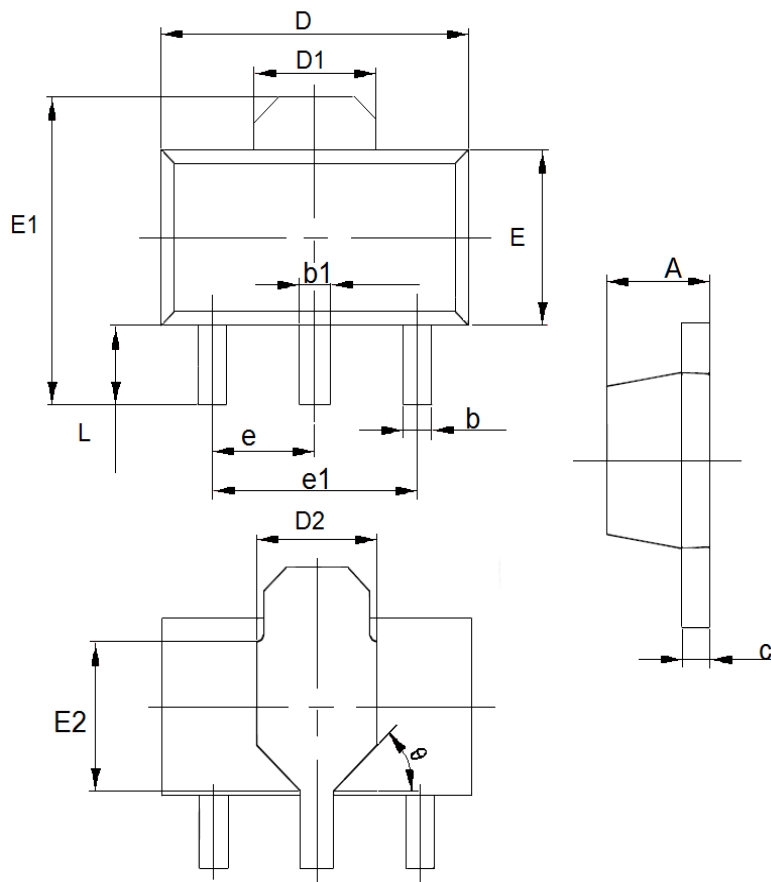

DIM	Millimeters		Inches	
	Min	Max	Min	Max
A	1.4	1.6	0.0551	0.0630
b	0.32	0.52	0.0126	0.0205
b1	0.4	0.58	0.0157	0.0228
c	0.35	0.45	0.0138	0.0177
D	4.4	4.6	0.1732	0.1811
D1	1.55(TYP)		0.061(TYP)	
D2	1.75(TYP)		0.0689(TYP)	
e1	3.0(TYP)		0.1181(TYP)	
E	2.3	2.6	0.0906	0.1023
E1	3.94	4.4	0.1551	0.1732
E2	1.9(TYP)		0.0748(TYP)	
e	1.5(TYP)		0.0591(TYP)	
L	0.8	1.2	0.0315	0.0472
θ	45°		45°	

● DFN3*3-8 (P=0.65)

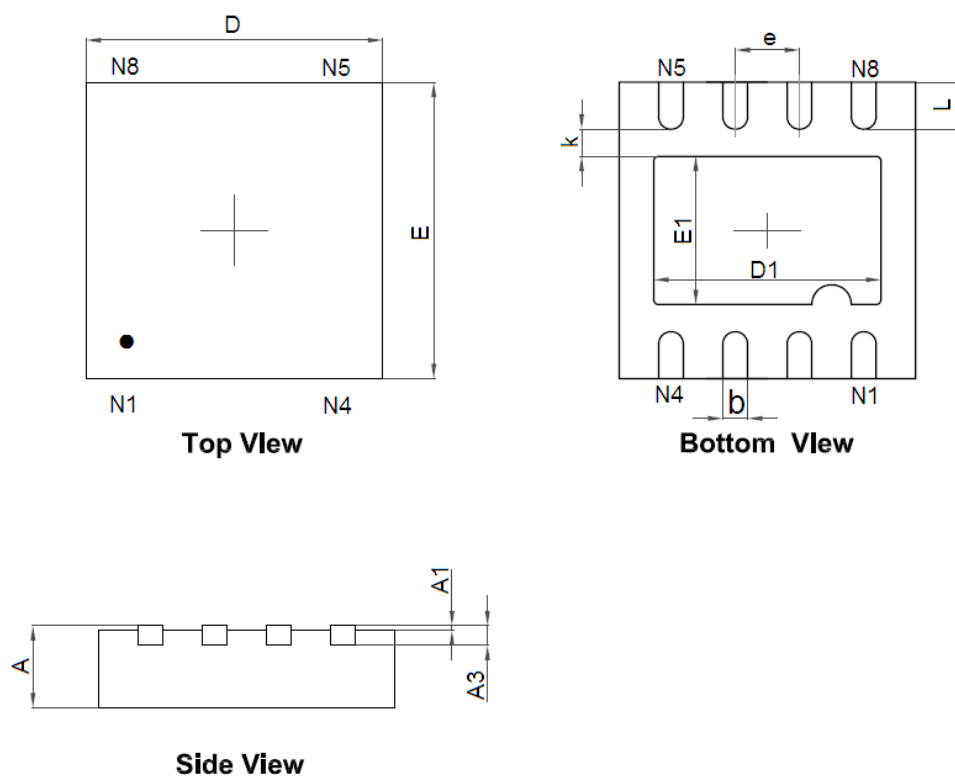

DIM	Millimeters		Inches	
	Min	Max	Min	Max
A	0.7	0.8	0.0276	0.0315
A1		0.05		0.002
A3	0.203 (TYP)		0.008(TYP)	
b	0.2	0.3	0.0079	0.0118
D	2.924	3.076	0.1151	0.1211
E	2.924	3.076	0.1151	0.1211
D1	2.2	2.4	0.0866	0.0945
E1	1.4	1.6	0.0551	0.0630
k	0.2		0.0079	
e	0.65(TYP)		0.0256(TYP)	
L	0.399	0.551	0.0157	0.0217

- The contents of this document will be updated with the product's improvement without prior notice. Please consult our sales staff before using this document to ensure that you are using the latest version.
- The application circuit examples described in this document are only used to indicate the representative use of the product and do not guarantee the design of mass production.
- Please use this product within the limits stated in this document. We will not be responsible for any damage caused by improper use.
- The products described in this document are not allowed to be used in equipment or devices that affect the human body without the written permission of our company, including but not limited to: health equipment, medical equipment, disaster prevention equipment, fuel control equipment, automobile equipment, aviation equipment and vehicle equipment.
- Although our company has always been committed to improving product quality and reliability, semiconductor products have a certain probability of malfunction or wrong work. To prevent personal injury or property damage caused by such accidents, please pay full attention to safety design, for example: Alternate design, fire protection design, and prevention of wrong action design.
- When exporting this product or this document overseas, you should abide by applicable import and export control laws.
- Copying or reprinting part or all of this document in any form without the permission of our company is strictly prohibited.

X-ON Electronics

Largest Supplier of Electrical and Electronic Components

Click to view similar products for [Linear Voltage Regulators](#) category:

Click to view products by [Micro One](#) manufacturer:

Other Similar products are found below :

[LV5684PVD-XH](#) [MCDTSA6-2R](#) [L7815ACV-DG](#) [LV56801P-E](#) [UA7805CKC](#) [714954EB](#) [ZMR500QFTA](#) [BA033LBSG2-TR](#)

[NCV78M05ABDTRKG](#) [LV5680P-E](#) [L79M05T-E](#) [L78LR05D-MA-E](#) [NCV317MBTG](#) [NTE7227](#) [MP2018GZD-33-P](#) [MP2018GZD-5-P](#)

[LV5680NPVC-XH](#) [ZTS6538SE](#) [UA78L09CLP](#) [UA78L09CLPR](#) [CAT6221-PPTD-GT3](#) [MC78M09CDTRK](#) [NCV51190MNTAG](#)

[BL1118CS8TR1833](#) [BL8563CKETR18](#) [BL8077CKETR33](#) [BL9153-33CC3TR](#) [BL9161G-15BADRN](#) [BL9161G-28BADRN](#)

[BRCO7530MMC](#) [CJ7815B-TFN-ARG](#) [LM317C](#) [GM7333K](#) [GM7350K](#) [XC6206P332MR](#) [HT7533](#) [LM7912S/TR](#) [LT1764S/TR](#) [LM7805T](#)

[LM338T](#) [LM1117IMP-3.3/TR](#) [HT1117AM-3.3](#) [HT7550S](#) [AMS1117-3.3](#) [HT7150S](#) [78L12](#) [HT7550](#) [HT7533-1](#) [HXY6206I-2.5](#) [HT7133](#)