



400mA Adjustable Voltage High Speed LDO Regulators ME6119 Series

General Description

The ME6119 series are highly accurate, low noise, LDO Voltage Regulators. On chip trimming adjusts the reference/output voltage to within $\pm 2\%$ accuracy. Internal protection features consist of output current limiting, safe operating area compensation, and thermal shutdown. The current limiter's feedback circuit also operates as a short protect for the output current limiter and the output pin. The CE function allows the output of regulator to be turned off, resulting in greatly reduced power consumption. The ME6119 series can operate with up to 18V input.

Features

- Maximum Output Current: 400mA
- Dropout Voltage: 104mV@ $I_{OUT} = 100mA$
- Operating Voltage Range: 2.5V~18V
- Highly Accuracy: $\pm 2\%$
- Adjustable Output Voltage Option
- Standby Current: 60uA (TYP.)
- Line Regulation: 30mV (TYP.)
- Temperature Stability $\leq 0.5\%$
- Thermal Shutdown Protection: 164°C

Typical Application

- Consumer and Industrial Equipment Point of Regulation
- Switching Power Supply Post Regulation
- Hard Drive Controllers

Package

- 3-pin SOT89-3
- 5-pin SOT23-5

Typical Application Circuit

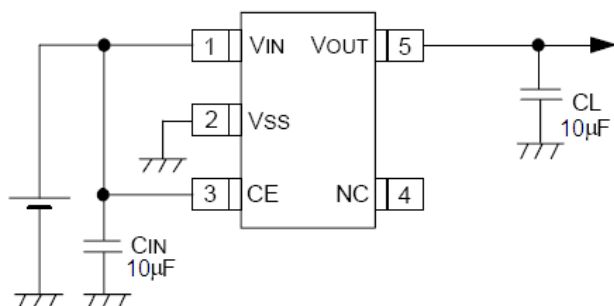

Selection Guide

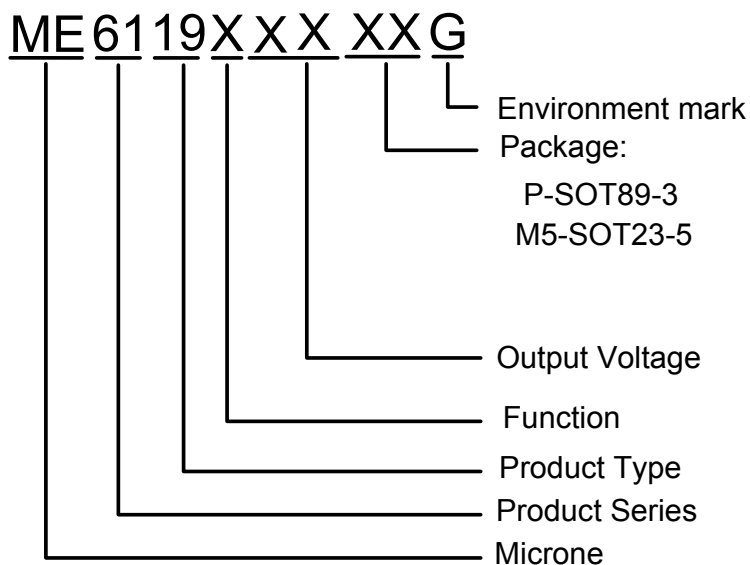

product series	product description
ME6119A30PG	V _{OUT} =3.0V; Have no enable ; Package: SOT89-3
ME6119C30M5G	V _{OUT} =3.0V; Have enable ; Package: SOT23-5

NOTE: At present ,there are five kinds of voltage value: 3.0V、3.3V、3.6V、4.0V、5.0V。
If you need other voltage and package, please contact our sales staff.

Pin Configuration

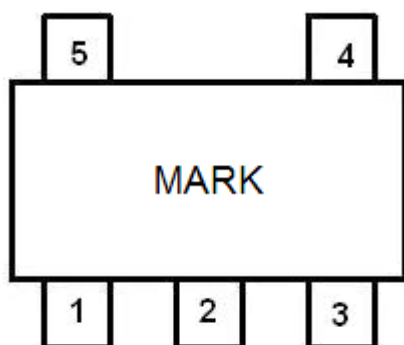

SOT23-5

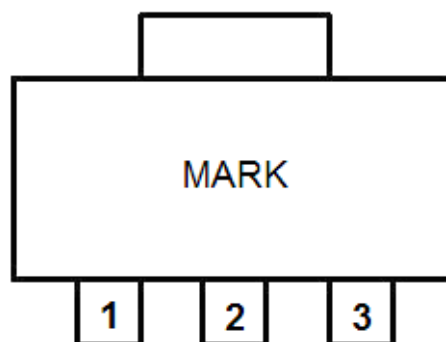

SOT89-3

Pin Assignment

ME6119CXX

Pin Number	Pin Name	Functions
SOT23-5		
1	V_{IN}	Power Input
2	V_{SS}	Ground
3	CE	ON / OFF Control
4	NC	No Connect
5	V_{OUT}	Output

ME6119AXX

Pin Number	Pin Name	Functions
SOT89-3		
1	V_{SS}	Ground
2	V_{IN}	Power Input
3	V_{OUT}	Output

Absolute Maximum Ratings

Parameter	Symbol	Ratings	Units	
Input Voltage	V_{IN}	18	V	
Output Current	I_{OUT}	500	mA	
Output Voltage	V_{OUT}	$V_{SS}-0.3 \sim V_{IN} + 0.3$	V	
CE Pin Voltage	V_{CE}	$V_{SS}-0.3 \sim V_{IN} + 0.3$	V	
Power Dissipation	SOT23-5	P_D	300	mW
	SOT89	P_D	500	mW
Operating Temperature Range	T_{OPR}	$-40 \sim +125$	$^{\circ}C$	
Storage Temperature Range	T_{STG}	$-40 \sim +150$	$^{\circ}C$	
Lead Temperature		$260^{\circ}C, 4sec$		

Block Diagram

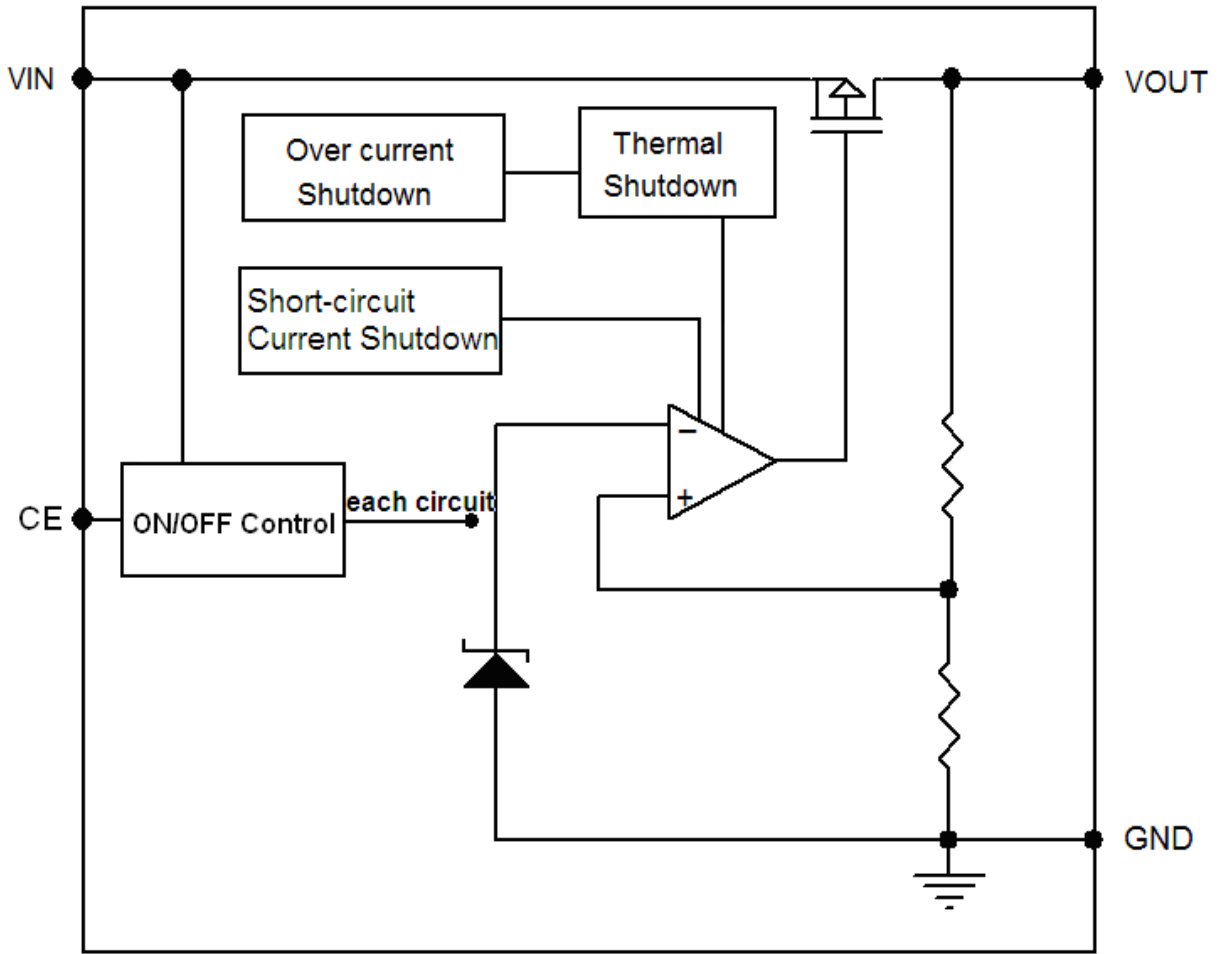

Electrical Characteristics

ME6119A33/C33

($V_{IN} = V_{OUT} + 1V$, $V_{CE} = V_{IN}$, $C_{IN} = C_L = 10\mu F$, $T_a = 25^\circ C$, unless otherwise noted)

Parameter	Symbol	Conditions	Min.	Typ.	Max.	Units
Output Voltage	$V_{OUT(E)}$ (Note 2)	$I_{OUT} = 30mA$, $V_{IN} = V_{OUT} + 1V$	X 0.98	$V_{OUT(T)}$ (Note 1)	X 1.02	V
Maximum Output Current	I_{OUTMAX}	$V_{IN} = V_{OUT} + 1V$		400		mA
Load Regulation	ΔV_{OUT}	$V_{IN} = V_{OUT} + 1V$, $1mA \leq I_{OUT} \leq 100mA$		8		mV
Dropout Voltage (Note 1)	V_{DIF1}	$I_{OUT} = 100mA$		130		mV
	V_{DIF2}	$I_{OUT} = 200mA$		260		mV
Supply Current	I_{SS}	$V_{IN} = V_{OUT} + 1V$		60		μA
Stand-by Current	I_{CEL}	$V_{CE} = 0V$		0		μA
Line Regulation	ΔV_{OUT}	$I_{OUT} = 30mA$ $V_{OUT} + 1V \leq V_{IN} \leq 18V$		20		mV
CE "High" Voltage	VCEH	Start up	1.20			V
CE "Low" Voltage	VCEL	Shut down			0.8	V
Short-circuit Current	I_{SHORT}	$V_{IN} = V_{OUT} + 1V$, $V_{CE} = V_{IN}$, $V_{OUT} = 0V$		60		mA
Thermal Shutdown Protection	T_{sd}	$I_{OUT} = 1mA$, $V_{IN} = V_{OUT} + 1V$		164		$^\circ C$
Over Current Protection	I_{limit}	$V_{IN} = 4.3V$		550		mA

ME6119A50/C50

($V_{IN} = V_{OUT} + 1V$, $V_{CE} = V_{IN}$, $C_{IN} = C_L = 10\mu F$, $T_a = 25^\circ C$, unless otherwise noted)

Parameter	Symbol	Conditions	Min.	Typ.	Max.	Units
Output Voltage	$V_{OUT(E)}$ (Note 2)	$I_{OUT} = 30mA$, $V_{IN} = V_{OUT} + 1V$	X 0.98	$V_{OUT(T)}$ (Note 1)	X 1.02	V
Maximum Output Current	I_{OUTMAX}	$V_{IN} = V_{OUT} + 1V$		400		mA
Load Regulation	ΔV_{OUT}	$V_{IN} = V_{OUT} + 1V$, $1mA \leq I_{OUT} \leq 100mA$		8		mV
Dropout Voltage (Note 1)	V_{DIF1}	$I_{OUT} = 100mA$		104		mV
	V_{DIF2}	$I_{OUT} = 200mA$		210		mV
Supply Current	I_{SS}	$V_{IN} = V_{OUT} + 1V$		60		μA
Stand-by Current	I_{CEL}	$V_{CE} = 0V$		0		μA
Line Regulation	ΔV_{OUT}	$I_{OUT} = 30mA$ $V_{OUT} + 1V \leq V_{IN} \leq 18V$		30		mV
CE "High" Voltage	V_{CEH}	Start up	1.20			V
CE "Low" Voltage	V_{CEL}	Shut down			0.8	V
Short-circuit Current	I_{SHORT}	$V_{IN} = V_{OUT} + 1V$, $V_{CE} = V_{IN}$, $V_{OUT} = 0V$		50		mA
Thermal Shutdown Protection	T_{sd}	$I_{OUT} = 1mA$, $V_{IN} = V_{OUT} + 1V$		164		$^\circ C$
Over Current Protection	I_{limit}	$V_{IN} = 6.0V$		510		mA

Note :

- $V_{OUT(T)}$: Specified Output Voltage
- $V_{OUT(E)}$: Effective Output Voltage (i.e. The output voltage when " $V_{OUT(T)} + 1.0V$ " is provided at the V_{in} pin while maintaining a certain I_{OUT} value.)
- V_{DIF} : $V_{IN1} - V_{OUT(E)}$
 V_{IN1} : The input voltage when $V_{OUT(E)}$ appears as input voltage is gradually decreased.
 $V_{OUT(E)}$ = A voltage equal to 98% of the output voltage whenever an amply stabilized $I_{OUT} \{V_{OUT(T)} + 1.0V\}$ is input.

Type Characteristics ($V_{OUT}=5.0V$)

(1) Output Voltage VS. Output Current
($V_{IN}=V_{OUT}+1V$)

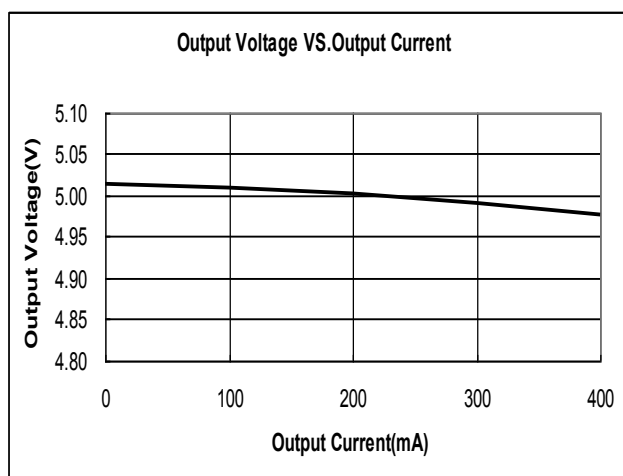

(2) Output Voltage VS. Temperature
($V_{IN}=V_{OUT}+1V, I_{OUT}=1mA$)

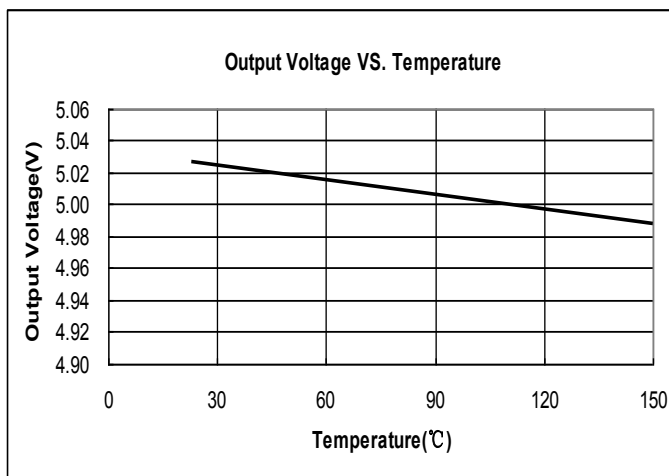

(3) Dropout Voltage VS. Output Current ($T_a = 25^\circ C$)

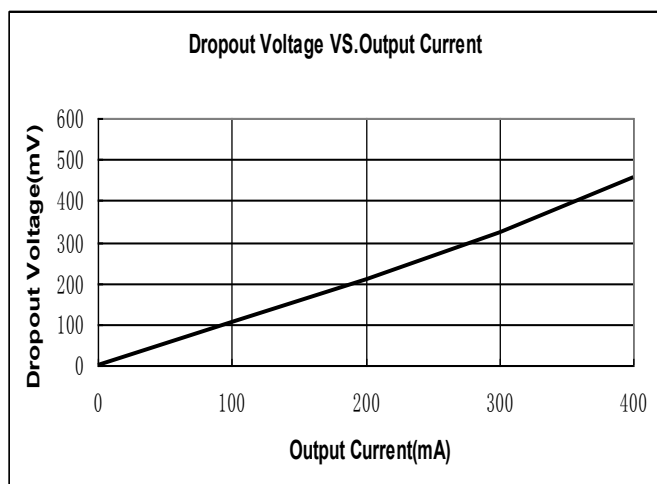

(4) Output Voltage VS. Input Voltage ($I_{OUT} = 10mA$)
($T_a = 25^\circ C$)

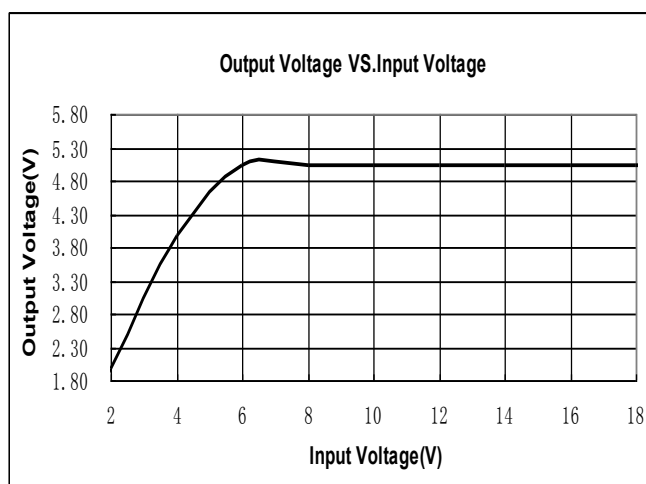

(5) Quiescent Current VS. Input Voltage

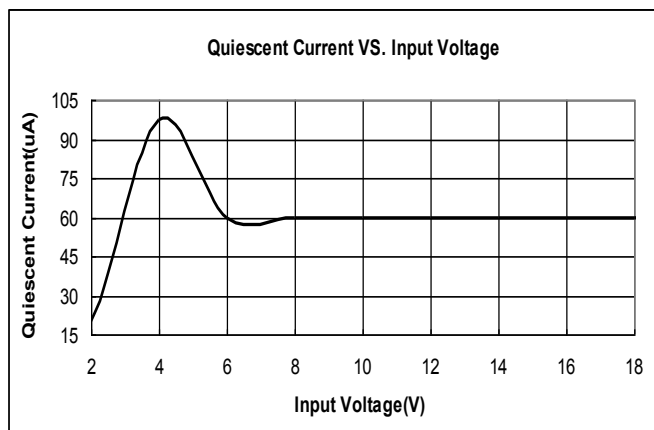

Applications Information

1. Input Bypass Capacitor

An input capacitor is recommended. A 10uF tantalum on the input is a suitable input bypassing for almost all applications.

2. Output Capacitor

The output capacitor is critical in maintaining regulator stability, and must meet the required conditions for both minimum amount of capacitance and ESR (Equivalent Series Resistance). The minimum output capacitance required by the ME6119 is 10μF, if a tantalum capacitor is used. Any increase of the output capacitance will merely improve the loop stability and transient response. The ESR of the output capacitor should be less than 0.5Ω.

3. Load Regulation

The ME6119 regulates the voltage that appears between its output and ground pins, or between its output and adjust pins. In some cases, line resistances can introduce errors to the voltage across the load. To obtain the best load regulation, a few precautions are needed. Figure1, shows a typical application using a fixed output regulator. The R_{t1} and R_{t2} are the line resistances. It is obvious that the V_{LOAD} is less than the V_{OUT} by the sum of the voltage drops along the line resistances. In this case, the load regulation seen at the R_{LOAD} would be degraded from the datasheet specification. To improve this, the load should be tied directly to the output terminal on the positive side and directly tied to the ground terminal on the negative side.

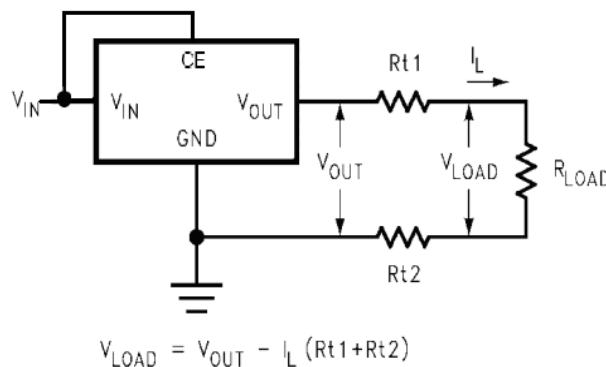
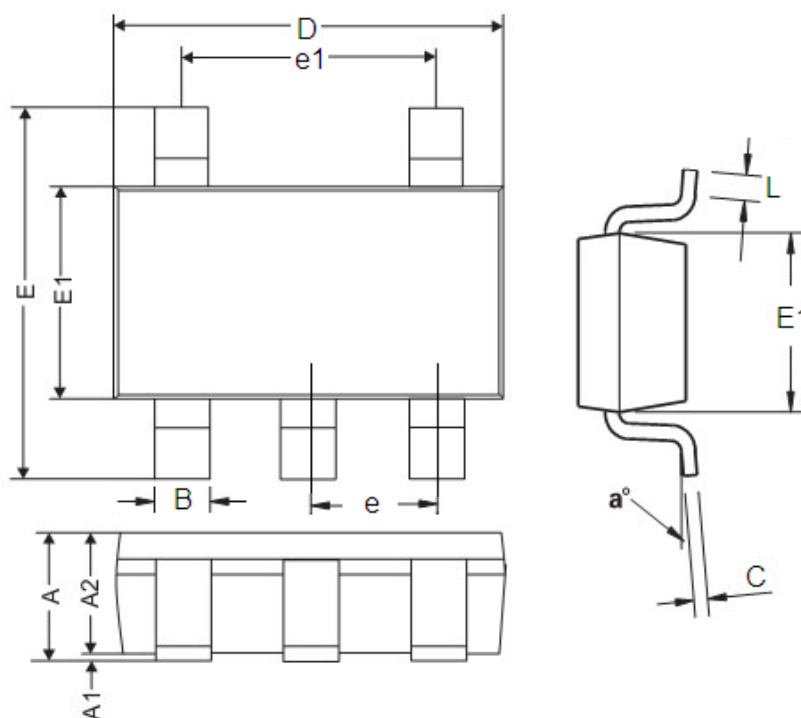

FIGURE 1. Typical Application using Fixed Output Regulator

Packaging Information

● SOT23-5 Unit: mm (inch)



DIM	Millimeters		Inches	
	Min	Max	Min	Max
A	0.9	1.45	0.0354	0.0570
A1	0	0.15	0	0.0059
A2	0.9	1.3	0.0354	0.0511
B	0.2	0.5	0.0078	0.0196
C	0.09	0.26	0.0035	0.0102
D	2.7	3.10	0.1062	0.1220
E	2.2	3.2	0.0866	0.1181
E1	1.30	1.80	0.0511	0.0708
e	0.95REF		0.0374REF	
e1	1.90REF		0.0748REF	
L	0.10	0.60	0.0039	0.0236
a°	0°	30°	0°	30°

● SOT89-3 Unit: mm (inch)

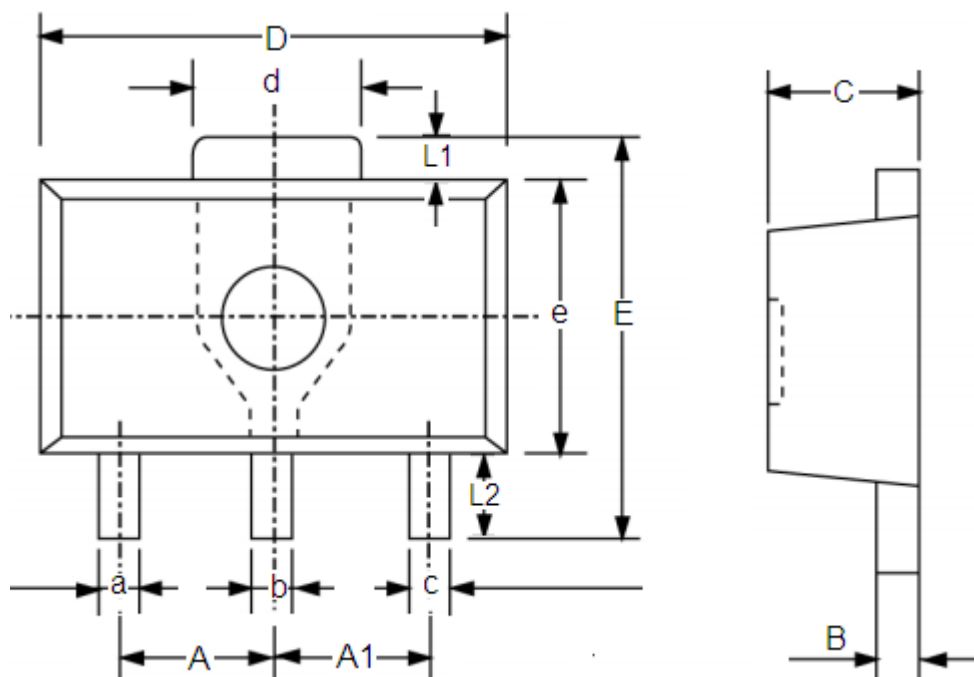

DIM	Millimeters		Inches	
	Min	Max	Min	Max
A	1.4	1.6	0.0551	0.0630
A1	1.4	1.6	0.0551	0.0630
a	0.36	0.48	0.0142	0.0189
b	0.41	0.53	0.0161	0.0209
c	0.36	0.48	0.0142	0.0189
d	1.4	1.75	0.0551	0.0689
B	0.38	0.43	0.015	0.0169
C	1.4	1.6	0.0551	0.0630
D	4.4	4.6	0.1732	0.181
E	-	4.25	-	0.1673
e	2.4	2.6	0.0945	0.1023
L1	0.4	-	0.0157	-
L2	0.8	-	0.0315	-

- The information described herein is subject to change without notice.
- Nanjing Micro One Electronics Inc is not responsible for any problems caused by circuits or diagrams described herein whose related industrial properties, patents, or other rights belong to third parties. The application circuit examples explain typical applications of the products, and do not guarantee the success of any specific mass-production design.
- Use of the information described herein for other purposes and/or reproduction or copying without the express permission of Nanjing Micro One Electronics Inc is strictly prohibited.
- The products described herein cannot be used as part of any device or equipment affecting the human body, such as exercise equipment, medical equipment, security systems, gas equipment, or any apparatus installed in airplanes and other vehicles, without prior written permission of Nanjing Micro One Electronics Inc.
- Although Nanjing Micro One Electronics Inc exerts the greatest possible effort to ensure high quality and reliability, the failure or malfunction of semiconductor products may occur. The user of these products should therefore give thorough consideration to safety design, including redundancy, fire-prevention measures, and malfunction prevention, to prevent any accidents, fires, or community damage that may ensue.

X-ON Electronics

Largest Supplier of Electrical and Electronic Components

Click to view similar products for [LDO Voltage Regulators](#) category:

Click to view products by [Micro One](#) manufacturer:

Other Similar products are found below :

[AP7363-SP-13](#) [L79M05TL-E](#) [AP7362-HA-7](#) [PT7M8202B12TA5EX](#) [TCR3DF185,LM\(CT](#) [TCR3DF45,LM\(CT](#) [TLE4473G V52](#) [059985X](#)
[NCP4687DH15T1G](#) [701326R](#) [NCV8170AXV250T2G](#) [AP7315-25W5-7](#) [AP2111H-1.2TRG1](#) [ZLDO1117QK50TC](#) [AZ1117ID-ADJTRG1](#)
[TCR3DG12,LF](#) [MIC5514-3.3YMT-T5](#) [SCD7912BTG](#) [NCP154MX180270TAG](#) [SCD33269T-5.0G](#) [NCV8170BXV330T2G](#)
[NCV8170BMX330TCG](#) [NCV8170AMX120TCG](#) [NCP706ABMX300TAG](#) [NCP153MX330180TCG](#) [NCP114BMX075TCG](#) [MC33269T-3.5G](#)
[CAT6243-ADJCMT5T](#) [TCR3DG33,LF](#) [TCR4DG35,LF](#) [TAR5S15U\(TE85L,F\)](#) [TAR5S18U\(TE85L,F\)](#) [TCR3UG19A,LF](#) [TCR4DG105,LF](#)
[MPQ2013AGG-5-P](#) [NCV8170AMX360TCG](#) [TLE4268GSXUMA2](#) [NCP715SQ15T2G](#) [MIC5317-3.0YD5-T5](#) [NCV563SQ18T1G](#)
[NCP715MX30TBG](#) [NCV8702MX25TCG](#) [NCV8170BXV120T2G](#) [MIC5317-1.2YD5-T5](#) [NCV8170AMX150TCG](#) [NCV8170BMX150TCG](#)
[AP2213D-3.3TRG1](#) [NCV8170BMX120TCG](#) [NCV8170BMX310TCG](#) [NCV8170BMX360TCG](#)