

## High Input Voltage LDO Linear Regulators ME6203 Series

### General Description

ME6203 series are low-dropout linear voltage regulators with a built-in voltage reference module, error correction module and phase compensation module. ME6203 series are based on the CMOS process and allow high voltage input with low quiescent current. This series can deliver 100mA output current and allow an input voltage as high as 40V. This series has the function of internal feedback resistor setting from 1.8V to 12V. There are two output accuracy levels:  $\pm 1\%$  ( $V_{OUT} = 3.3V, 5.0V, 10.0V$ ) and  $\pm 2\%$  (other voltage values).

### Typical Application

- Electronic weighbridge
- SCM
- Phones, cordless phones
- Security Products
- Water meters, power meters

### Typical Application

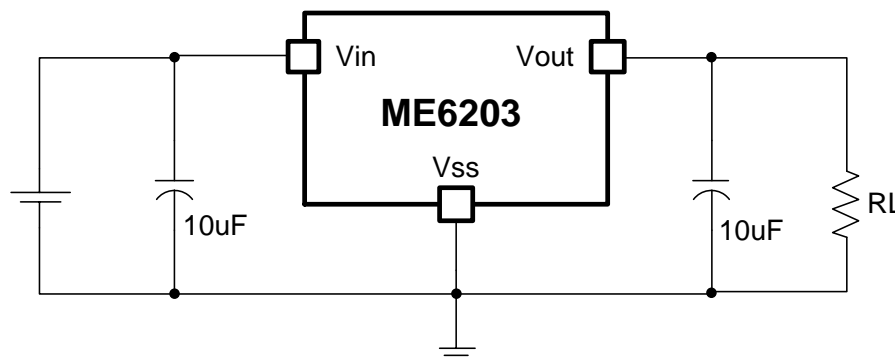

**Suggesting :** The circuit uses the electrolytic capacitors or tantalum capacitors in the best ,when it is applied in the high input voltage.

### Features

- High output accuracy:
  - $\pm 1\%$  ( $V_{OUT} = 3.3V, 5.0V, 10V$ )
  - $\pm 2\%$  (Others)
- Input voltage: up to 40 V
- Output voltage: 1.8V ~ 12V
- Ultra-low quiescent current (Typ.= 3  $\mu$  A)
- Output Current:  $I_{OUT} = 100mA$   
(When  $V_{IN} = 5.5V$  and  $V_{OUT} = 3.3V$ )
- Short-circuit Current: (Typ.= 20mA)
- Low temperature coefficient
- Ceramic capacitor can be used

### Package

- 3-pin SOT89-3 、 SOT23-3 、 TO92

## Selection Guide

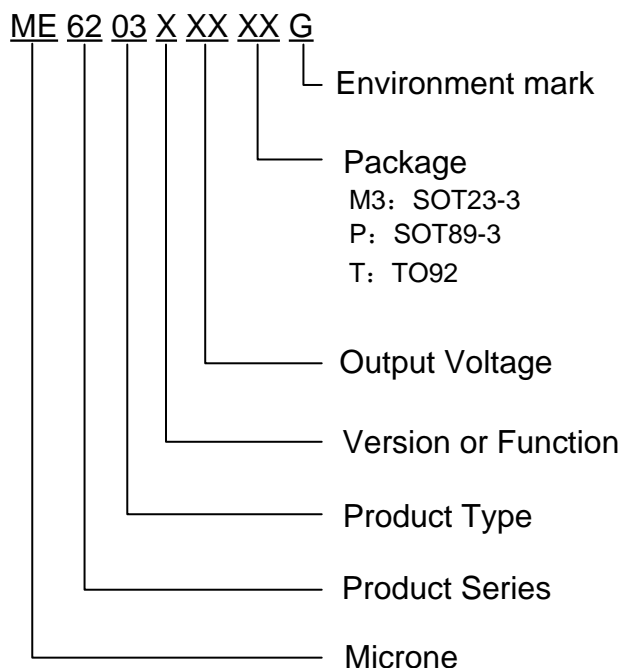

product series	product description
ME6203A18M3G	$V_{OUT} = 1.8V \pm 2\%$ ; Package: SOT23-3
ME6203A18PG	$V_{OUT} = 1.8V \pm 2\%$ ; Package: SOT89-3
ME6203A25M3G	$V_{OUT} = 2.5V \pm 2\%$ ; Package: SOT23-3
ME6203A25PG	$V_{OUT} = 2.5V \pm 2\%$ ; Package: SOT89-3
ME6203A30M3G	$V_{OUT} = 3.0V \pm 2\%$ ; Package: SOT23-3
ME6203A30PG	$V_{OUT} = 3.0V \pm 2\%$ ; Package: SOT89-3
ME6203A33M3G	$V_{OUT} = 3.3V \pm 1\%$ ; Package: SOT23-3
ME6203A33PG	$V_{OUT} = 3.3V \pm 1\%$ ; Package: SOT89-3
ME6203A33TG	$V_{OUT} = 3.3V \pm 1\%$ ; Package: TO92
ME6203A36M3G	$V_{OUT} = 3.6V \pm 2\%$ ; Package: OT23-3
ME6203A36PG	$V_{OUT} = 3.6V \pm 2\%$ ; Package: OT89-3
ME6203A36TG	$V_{OUT} = 3.6V \pm 2\%$ ; Package: TO92
ME6203A44M3G	$V_{OUT} = 4.4V \pm 2\%$ ; Package: SOT23-3
ME6203A44PG	$V_{OUT} = 4.4V \pm 2\%$ ; Package: SOT89-3
ME6203A50M3G	$V_{OUT} = 5.0V \pm 1\%$ ; Package: SOT23-3
ME6203A50PG	$V_{OUT} = 5.0V \pm 1\%$ ; Package: SOT89-3
ME6203A50TG	$V_{OUT} = 5.0V \pm 1\%$ ; Package: TO92
ME6203A100M3G	$V_{OUT} = 10.0V \pm 1\%$ ; Package: SOT23-3
ME6203A100PG	$V_{OUT} = 10.0V \pm 1\%$ ; Package: SOT89-3

**NOTE:** If you need other voltage and package, please contact our sales staff.

## Pin Configuration

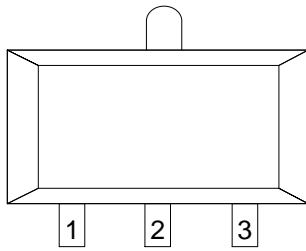

SOT-89-3

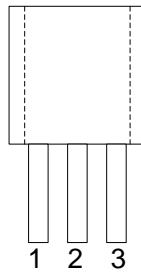

TO-92

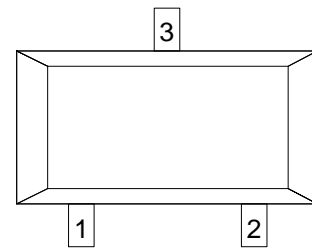

SOT23-3

## Pin Assignment

Pin Number		Pin Name	Functions
SOT89-3 / TO92	SOT23-3		
1	1	$V_{SS}$	Ground
2	3	$V_{IN}$	Power Input
3	2	$V_{OUT}$	Output

## Block Diagram

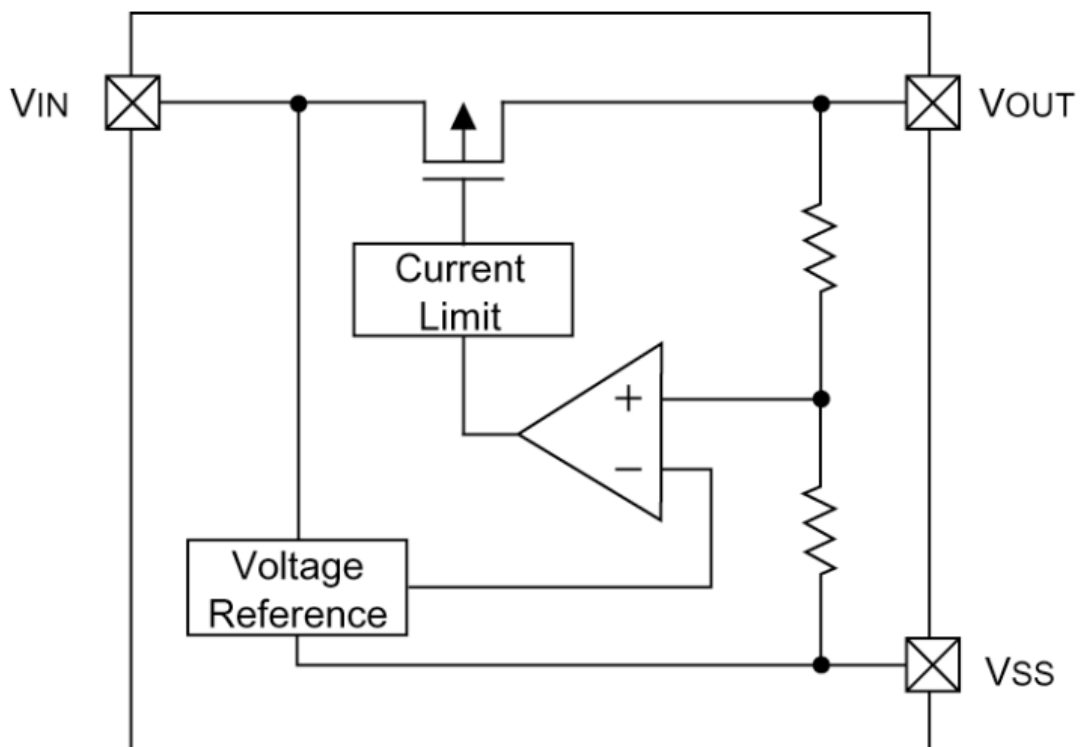

## Absolute Maximum Ratings

Parameter		Symbol	Ratings	Units
Input Voltage		$V_{IN}$	40	V
Output Current		$I_{OUT}$	150	mA
Output Voltage		$V_{OUT}$	$V_{SS}-0.3 \sim V_{IN} + 0.3$	V
Power Dissipation	SOT23-3	$P_D$	0.54	W
	SOT89-3		1.25	
	TO-92		0.83	
Thermal resistance	SOT23-3	$\theta_{JA}$	230	°C / W
	SOT89-3		100	
	TO-92		150	
Operating Ambient Temperature Range		$T_{OPR}$	-40 ~ +85	°C
Storage Temperature Range		$T_{STG}$	-55 ~ +150	°C
Maximum junction temperature		$T_J$	-40 ~ +150	°C
Lead Temperature		$T_{solder}$	260°C, 10sec	

## Electrical Characteristics

**ME6203A18** ( $V_{IN} = V_{OUT} + 2.0V$ ,  $C_{IN} = C_L = 10\mu F$ ,  $T_a = 25^\circ C$ , unless otherwise noted)

Parameter	Symbol	Conditions	Min.	Typ.	Max.	Units
Output Voltage	$V_{OUT(E)}$ (Note 2)	$I_{OUT} = 10mA$	X 0.98	$V_{OUT(T)}$ (Note 1)	X 1.02	V
Input Voltage	$V_{IN}$		3.0		40	V
Maximum Output Current	$I_{OUT\_max}$	$V_{IN} = V_{OUT} + 3.7V$		100		mA
Load Regulation	$\Delta V_{OUT}$	$V_{IN} = V_{OUT} + 3.7V$ , $1mA \leq I_{OUT} \leq 100mA$		30	60	mV
Dropout Voltage (Note 3)	$V_{DIF}$	$I_{OUT} = 100mA$		3.7		V
Supply Current	$I_{SS}$	$V_{IN} = V_{OUT} + 2V$		2.0	4	$\mu A$
Line Regulations	$\frac{\Delta V_{OUT}}{\Delta V_{IN} \times V_{OUT}}$	$I_{OUT} = 1mA$ $V_{OUT} + 1V \leq V_{IN} \leq 40V$		0.03	0.1	%/V
Short-circuit Current	$I_{SHORT}$	$V_{OUT} = V_{SS}$		20	40	mA
Temperature Coefficient (Note 4)	$\frac{\Delta V_{OUT}}{V_{OUT} \times \Delta T_a}$	$I_{OUT} = 10mA$ $-40^\circ C \leq T_a \leq 85^\circ C$		80		ppm/°C

**ME6203A25** ( $V_{IN} = V_{OUT} + 2.0V$ ,  $C_{IN} = C_L = 10\mu F$ ,  $T_a = 25^\circ C$ , unless otherwise noted)

Parameter	Symbol	Conditions	Min.	Typ.	Max.	Units
Output Voltage	$V_{OUT(E)}$ (Note 2)	$I_{OUT} = 10mA$	X 0.98	$V_{OUT(T)}$ (Note 1)	X 1.02	V
Input Voltage	$V_{IN}$		3.0		40	V
Maximum Output Current	$I_{OUT\_max}$	$V_{IN} = V_{OUT} + 3.0V$		100		mA

Load Regulation	$\Delta V_{OUT}$	$V_{IN} = V_{OUT} + 3.0V$ , $1mA \leq I_{OUT} \leq 100mA$		32	60	mV
Dropout Voltage (Note 3)	$V_{DIF}$	$I_{OUT} = 100mA$		3.0		V
Supply Current	$I_{SS}$	$V_{IN} = V_{OUT} + 2V$		2.5	4	$\mu A$
Line Regulations	$\frac{\Delta V_{OUT}}{\Delta V_{IN} \times V_{OUT}}$	$I_{OUT} = 1mA$ $V_{OUT} + 1V \leq V_{IN} \leq 40V$		0.02	0.1	%/V
Short-circuit Current	$I_{SHORT}$	$V_{OUT} = V_{SS}$		20	40	mA
Temperature Coefficient(Note 4)	$\frac{\Delta V_{OUT}}{V_{OUT} \times \Delta Ta}$	$I_{OUT} = 10mA$ $-40^{\circ}C \leq Ta \leq 85^{\circ}C$		80		ppm/ $^{\circ}C$

**ME6203A30** ( $V_{IN} = V_{OUT} + 2.0V$ ,  $C_{IN} = C_L = 10\mu F$ ,  $Ta = 25^{\circ}C$ , unless otherwise noted)

Parameter	Symbol	Conditions	Min.	Typ.	Max.	Units
Output Voltage	$V_{OUT(E)}$ (Note 2)	$I_{OUT} = 10mA$	X 0.98	$V_{OUT(T)}$ (Note 1)	X 1.02	V
Input Voltage	$V_{IN}$		3.0		40	V
Maximum Output Current	$I_{OUT\_max}$	$V_{IN} = V_{OUT} + 2.5V$		100		mA
Load Regulation	$\Delta V_{OUT}$	$V_{IN} = V_{OUT} + 2.5V$ , $1mA \leq I_{OUT} \leq 100mA$		30	60	mV
Dropout Voltage (Note 3)	$V_{DIF}$	$I_{OUT} = 10mA$		0.25		V
		$I_{OUT} = 50mA$		1.2		V
Supply Current	$I_{SS}$	$V_{IN} = V_{OUT} + 2V$		3	4	$\mu A$
Line Regulations	$\frac{\Delta V_{OUT}}{\Delta V_{IN} \times V_{OUT}}$	$I_{OUT} = 1mA$ $V_{OUT} + 1V \leq V_{IN} \leq 40V$		0.02	0.1	%/V
Short-circuit Current	$I_{SHORT}$	$V_{OUT} = V_{SS}$		20	40	mA
Temperature Coefficient(Note 4)	$\frac{\Delta V_{OUT}}{V_{OUT} \times \Delta Ta}$	$I_{OUT} = 10mA$ $-40^{\circ}C \leq Ta \leq 85^{\circ}C$		80		ppm/ $^{\circ}C$

**ME6203A33** ( $V_{IN} = V_{OUT} + 2.0V$ ,  $C_{IN} = C_L = 10\mu F$ ,  $Ta = 25^{\circ}C$ , unless otherwise noted)

Parameter	Symbol	Conditions	Min.	Typ.	Max.	Units
Output Voltage	$V_{OUT(E)}$ (Note 2)	$I_{OUT} = 10mA$	X 0.99	$V_{OUT(T)}$ (Note 1)	X 1.01	V
Input Voltage	$V_{IN}$		3.3		40	V
Maximum Output Current	$I_{OUT\_max}$	$V_{IN} = V_{OUT} + 2.2V$		100		mA
Load Regulation	$\Delta V_{OUT}$	$V_{IN} = V_{OUT} + 2.2V$ , $1mA \leq I_{OUT} \leq 100mA$		30	60	mV
Dropout Voltage (Note 3)	$V_{DIF}$	$I_{OUT} = 10mA$		0.22		V
		$I_{OUT} = 50mA$		1.1		V
Supply Current	$I_{SS}$	$V_{IN} = V_{OUT} + 2V$		3	4	$\mu A$

Line Regulations	$\frac{\Delta V_{OUT}}{\Delta V_{IN} \times V_{OUT}}$	$I_{OUT} = 1\text{mA}$ $V_{OUT} + 1\text{V} \leq V_{IN} \leq 40\text{V}$	0.04	0.1	%/V
Short-circuit Current	$I_{SHORT}$	$V_{OUT} = V_{SS}$	20	40	mA
Temperature Coefficient(Note 4)	$\frac{\Delta V_{OUT}}{V_{OUT} \times \Delta T_a}$	$I_{OUT} = 10\text{mA}$ $-40^\circ\text{C} \leq T_a \leq 85^\circ\text{C}$	80		ppm/°C

**ME6203A36** ( $V_{IN} = V_{OUT} + 2.0\text{V}$ ,  $C_{IN} = C_L = 10\mu\text{F}$ ,  $T_a = 25^\circ\text{C}$ , unless otherwise noted)

Parameter	Symbol	Conditions	Min.	Typ.	Max.	Units
Output Voltage	$V_{OUT(E)}$ (Note 2)	$I_{OUT} = 10\text{mA}$	X 0.98	$V_{OUT(T)}$ (Note 1)	X 1.02	V
Input Voltage	$V_{IN}$		3.6		40	V
Maximum Output Current	$I_{OUT\_max}$	$V_{IN} = V_{OUT} + 2.2\text{V}$		100		mA
Load Regulation	$\Delta V_{OUT}$	$V_{IN} = V_{OUT} + 2.2\text{V}$ , $1\text{mA} \leq I_{OUT} \leq 100\text{mA}$		30	60	mV
Dropout Voltage (Note 3)	$V_{DIF}$	$I_{OUT} = 10\text{mA}$		0.20		V
		$I_{OUT} = 50\text{mA}$		1.0		V
Supply Current	$I_{SS}$	$V_{IN} = V_{OUT} + 2\text{V}$		3	4	$\mu\text{A}$
Line Regulations	$\frac{\Delta V_{OUT}}{\Delta V_{IN} \times V_{OUT}}$	$I_{OUT} = 1\text{mA}$ $V_{OUT} + 1\text{V} \leq V_{IN} \leq 40\text{V}$		0.02	0.1	%/V
Short-circuit Current	$I_{SHORT}$	$V_{OUT} = V_{SS}$		20	40	mA
Temperature Coefficient(Note 4)	$\frac{\Delta V_{OUT}}{V_{OUT} \times \Delta T_a}$	$I_{OUT} = 10\text{mA}$ $-40^\circ\text{C} \leq T_a \leq 85^\circ\text{C}$		80		ppm/°C

**ME6203A44** ( $V_{IN} = V_{OUT} + 2.0\text{V}$ ,  $C_{IN} = C_L = 10\mu\text{F}$ ,  $T_a = 25^\circ\text{C}$ , unless otherwise noted)

Parameter	Symbol	Conditions	Min.	Typ.	Max.	Units
Output Voltage	$V_{OUT(E)}$ (Note 2)	$I_{OUT} = 10\text{mA}$	X 0.98	$V_{OUT(T)}$ (Note 1)	X 1.02	V
Input Voltage	$V_{IN}$		4.4		40	V
Maximum Output Current	$I_{OUT\_max}$	$V_{IN} = V_{OUT} + 2.0\text{V}$		100		mA
Load Regulation	$\Delta V_{OUT}$	$V_{IN} = V_{OUT} + 2.0\text{V}$ , $1\text{mA} \leq I_{OUT} \leq 100\text{mA}$		31	60	mV
Dropout Voltage (Note 3)	$V_{DIF}$	$I_{OUT} = 10\text{mA}$		0.17		V
		$I_{OUT} = 50\text{mA}$		0.82		V
Supply Current	$I_{SS}$	$V_{IN} = V_{OUT} + 2\text{V}$		3	4	$\mu\text{A}$
Line Regulations	$\frac{\Delta V_{OUT}}{\Delta V_{IN} \times V_{OUT}}$	$I_{OUT} = 1\text{mA}$ $V_{OUT} + 1\text{V} \leq V_{IN} \leq 40\text{V}$		0.02	0.1	%/V
Short-circuit Current	$I_{SHORT}$	$V_{OUT} = V_{SS}$		20	40	mA
Temperature Coefficient(Note 4)	$\frac{\Delta V_{OUT}}{V_{OUT} \times \Delta T_a}$	$I_{OUT} = 10\text{mA}$ $-40^\circ\text{C} \leq T_a \leq 85^\circ\text{C}$		80		ppm/°C

**ME6203A50** ( $V_{IN} = V_{OUT} + 2.0V$ ,  $C_{IN} = C_L = 10\mu F$ ,  $T_a = 25^\circ C$ , unless otherwise noted)

Parameter	Symbol	Conditions	Min.	Typ.	Max.	Units
Output Voltage	$V_{OUT(E)}$ (Note 2)	$I_{OUT} = 10mA$	X 0.99	$V_{OUT(T)}$ (Note 1)	X 1.01	V
Input Voltage	$V_{IN}$		5.0		40	V
Maximum Output Current	$I_{OUT\_max}$	$V_{IN} = V_{OUT} + 2.0V$		100		mA
Load Regulation	$\Delta V_{OUT}$	$V_{IN} = V_{OUT} + 2.0V$ , $1mA \leq I_{OUT} \leq 100mA$		33	60	mV
Dropout Voltage (Note 3)	$V_{DIF}$	$I_{OUT} = 10mA$		0.13		V
		$I_{OUT} = 50mA$		0.68		V
Supply Current	$I_{SS}$	$V_{IN} = V_{OUT} + 2V$		3.3	4.5	$\mu A$
Line Regulations	$\frac{\Delta V_{OUT}}{\Delta V_{IN} \times V_{OUT}}$	$I_{OUT} = 1mA$ $V_{OUT} + 1V \leq V_{IN} \leq 40V$		0.03	0.1	%/V
Short-circuit Current	$I_{SHORT}$	$V_{OUT} = V_{SS}$		25	40	mA
Temperature Coefficient (Note 4)	$\frac{\Delta V_{OUT}}{V_{OUT} \times \Delta T_a}$	$I_{OUT} = 10mA$ $-40^\circ C \leq T_a \leq 85^\circ C$		80		ppm/ $^\circ C$

**ME6203A100** ( $V_{IN} = V_{OUT} + 1.5V$ ,  $C_{IN} = C_L = 10\mu F$ ,  $T_a = 25^\circ C$ , unless otherwise noted)

Parameter	Symbol	Conditions	Min.	Typ.	Max.	Units
Output Voltage	$V_{OUT(E)}$ (Note 2)	$I_{OUT} = 10mA$	X 0.99	$V_{OUT(T)}$ (Note 1)	X 1.01	V
Input Voltage	$V_{IN}$		10.0	-	40	V
Maximum Output Current	$I_{OUT\_max}$	$V_{IN} = V_{OUT} + 1.5V$	-	100	-	mA
Load Regulation	$\Delta V_{OUT}$	$V_{IN} = V_{OUT} + 1.5V$ , $1mA \leq I_{OUT} \leq 100mA$	-	20	60	mV
Dropout Voltage (Note 3)	$V_{DIF}$	$I_{OUT} = 10mA$	-	0.09	-	V
		$I_{OUT} = 50mA$	-	0.45	-	V
Supply Current	$I_{SS}$	$V_{IN} = V_{OUT} + 1.5V$	-	5	7.5	$\mu A$
Line Regulations	$\frac{\Delta V_{OUT}}{\Delta V_{IN} \times V_{OUT}}$	$I_{OUT} = 1mA$ $V_{OUT} + 1V \leq V_{IN} \leq 40V$	-	0.02	0.1	%/V
Short-circuit Current	$I_{SHORT}$	$V_{OUT} = V_{SS}$	-	30	40	mA
Temperature Coefficient (Note 4)	$\frac{\Delta V_{OUT}}{V_{OUT} \times \Delta T_a}$	$I_{OUT} = 10mA$ $-40^\circ C \leq T_a \leq 85^\circ C$	-	80	-	ppm/ $^\circ C$

**Note :**

- $V_{OUT(T)}$  : Specified Output Voltage
- $V_{OUT(E)}$  : Effective Output Voltage ( ie. The output voltage when " $V_{OUT(T)} + 2.0V$ " is provided at the  $V_{IN}$  pin while maintaining a certain  $I_{OUT}$  value.)
- $V_{DIF} = V_{IN1} - V_{OUT(E)}$   
 $V_{IN1}$  : The input voltage when  $V_{OUT(E)}$  appears as input voltage is gradually decreased.  
 $V_{OUT(E)}$  : A voltage equal to 98% of the output voltage whenever an amply stabilized  $I_{OUT}$  and  $\{V_{OUT(T)} + 2.2V\}$  is input.
- guaranteed by design.

## Type Characteristics

(1) Input Voltage VS. Output Voltage (  $T_a = 25\text{ }^\circ\text{C}$  )

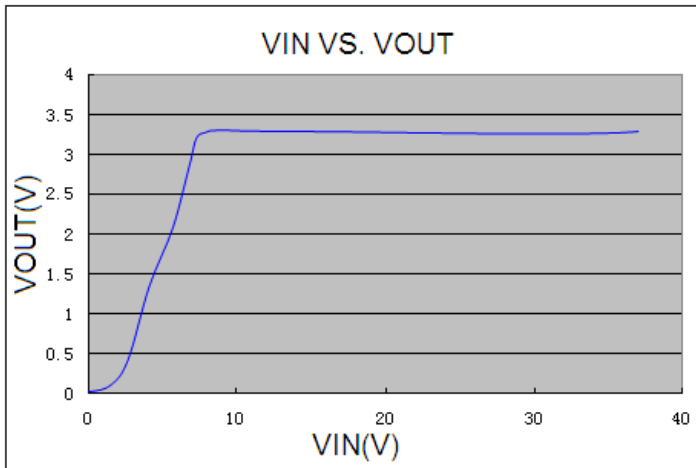

(2) Quiescent Current VS. Input Voltage (  $T_a = 25\text{ }^\circ\text{C}$  )

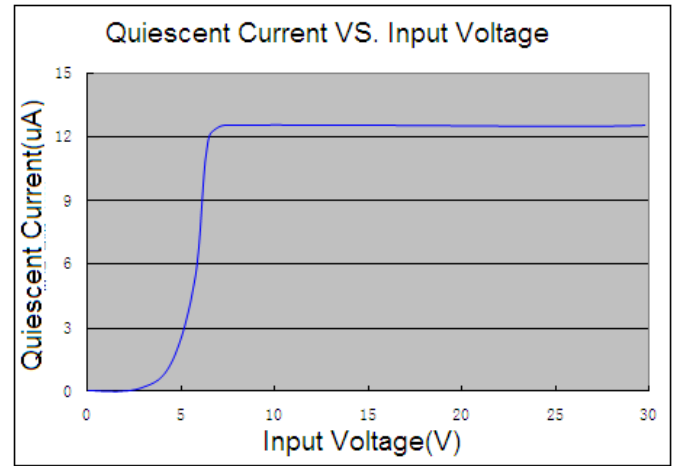

(3) Output Voltage VS. Output Current (  $T_a = 25\text{ }^\circ\text{C}$  )

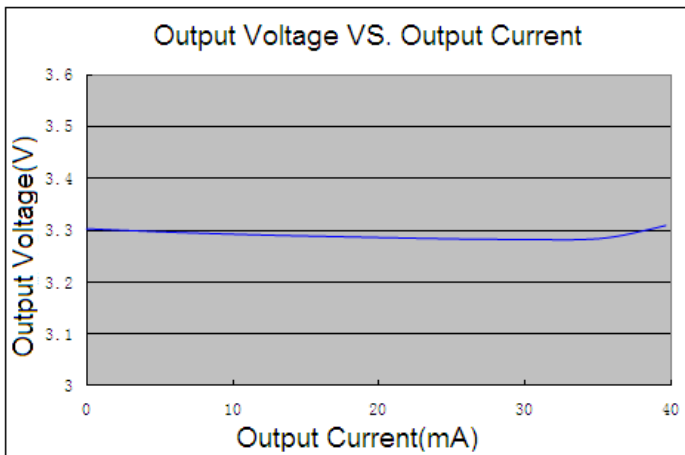

(4) Output Voltage VS. Temperature

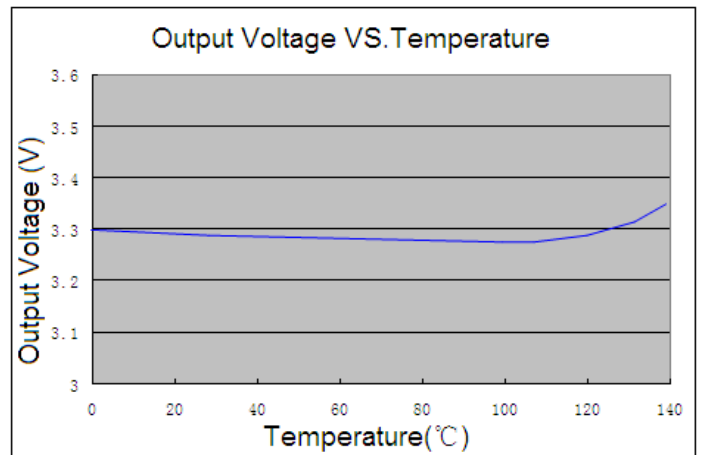

(5) Max output current VS. Input Voltage (  $T_a = 25\text{ }^\circ\text{C}$  )

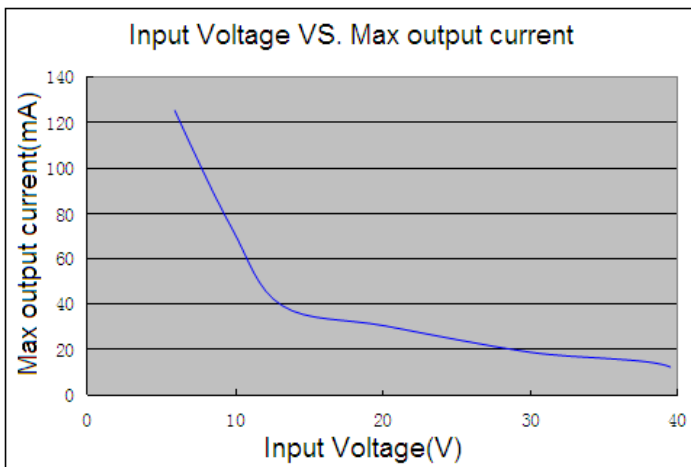

(6) Quiescent Current VS. Temperature

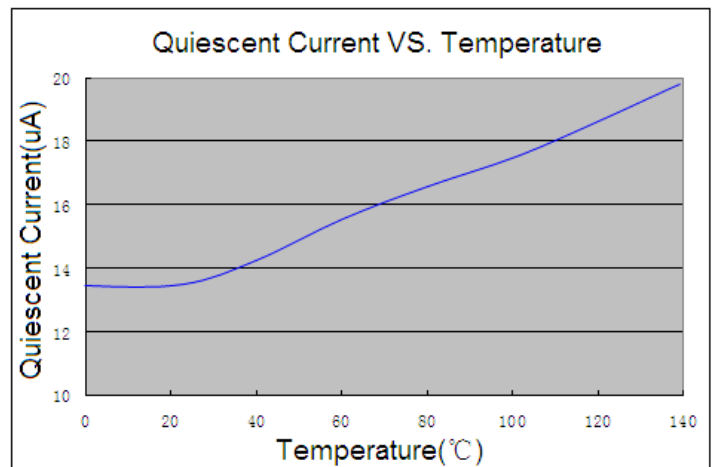



(7) Start Time(CH1:  $V_{IN}=18V$ , CH2: $V_{OUT}=3.3V$ ,  $T_A=25^{\circ}C$ )

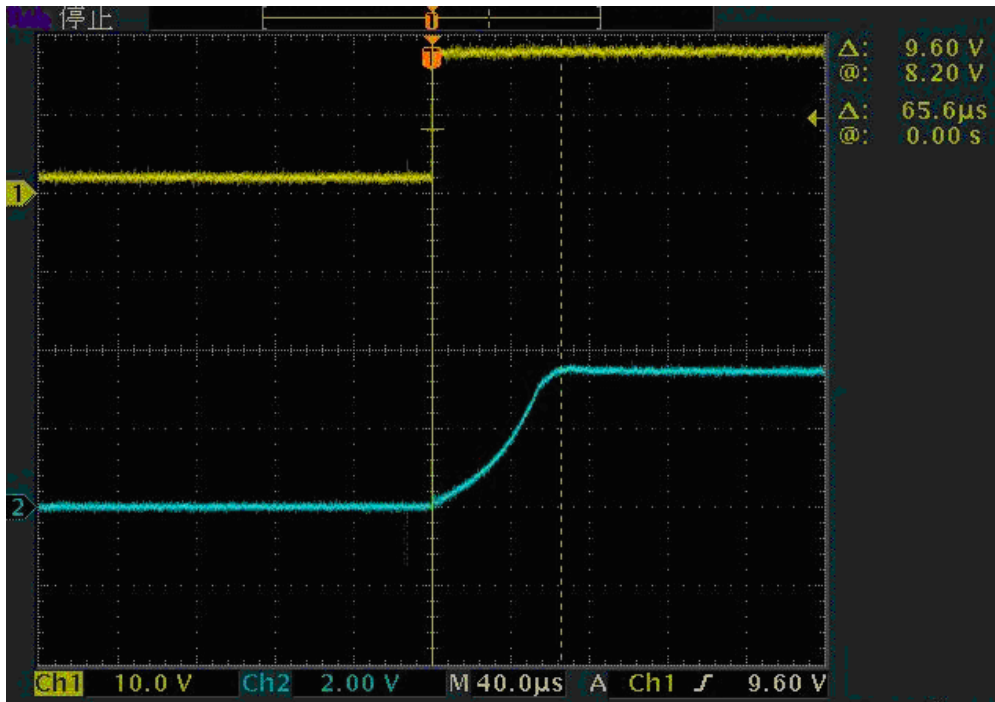

## Packaging Information

- Packaging Type: SOT89-3

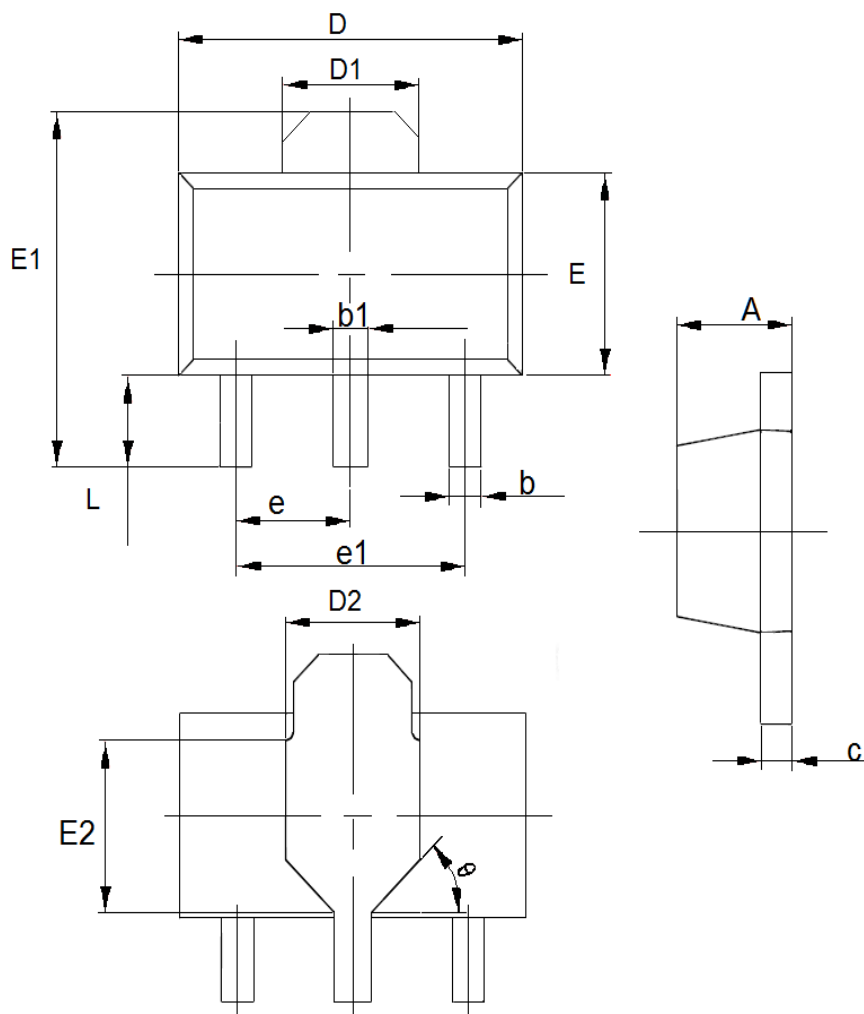

DIM	Millimeters		Inches	
	Min	Max	Min	Max
A	1.4	1.6	0.0551	0.0630
b	0.32	0.52	0.0126	0.0205
b1	0.4	0.58	0.0157	0.0228
c	0.35	0.45	0.0138	0.0177
D	4.4	4.6	0.1732	0.1811
D1	1.55(TYP)		0.061(TYP)	
D2	1.75(TYP)		0.0689(TYP)	
e1	3.0(TYP)		0.1181(TYP)	
E	2.3	2.6	0.0906	0.1023
E1	3.94	4.4	0.1551	0.1732
E2	1.9(TYP)		0.0748(TYP)	
e	1.5(TYP)		0.0591(TYP)	
L	0.8	1.2	0.0315	0.0472
θ	45°		45°	

● Packaging Type: TO92

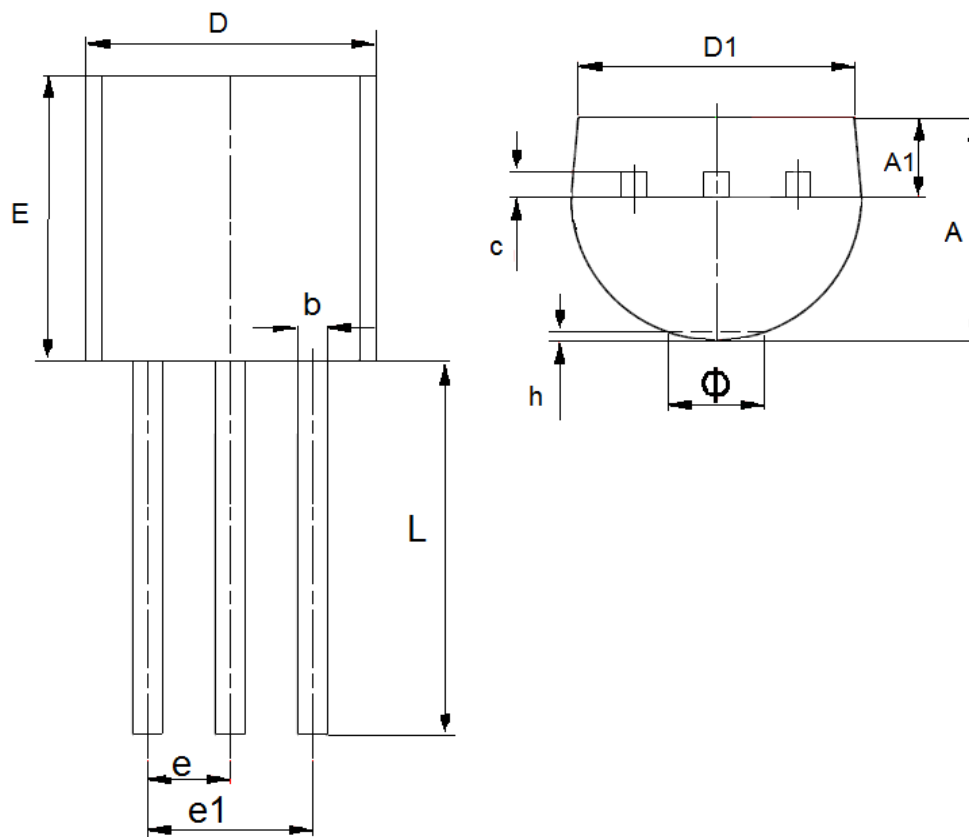

DIM	Millimeters		Inches	
	Min	Max	Min	Max
A	3.3	3.7	0.1299	0.1457
A1	1.1	1.4	0.0433	0.0551
b	0.38	0.55	0.015	0.0217
c	0.36	0.51	0.0142	0.0201
D	4.3	4.7	0.1693	0.185
D1	3.43	—	0.135	—
E	4.3	4.7	0.1693	0.185
e	1.27TYP		0.05TYP	
e1	2.44	2.64	0.0961	0.1039
L	14.1	14.5	0.5551	0.5709
h	0	0.38	0	0.015
Φ	—	1.6	—	0.063

● Packaging Type: SOT23-3

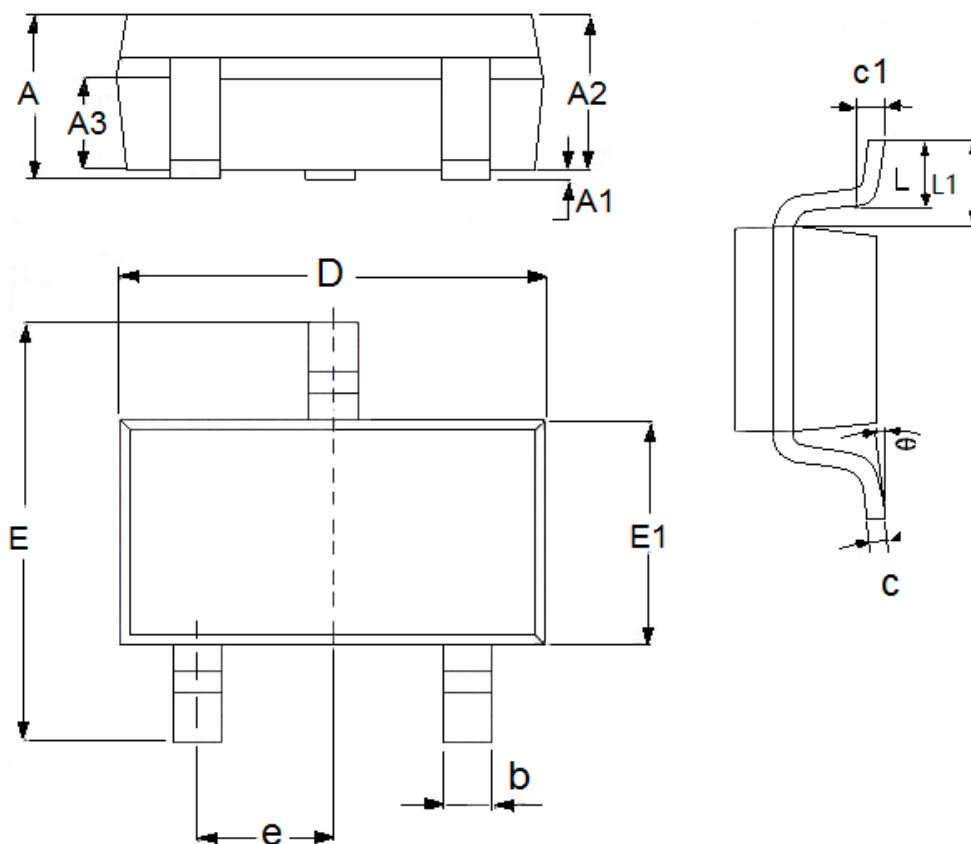

DIM	Millimeters		Inches	
	Min	Max	Min	Max
A	1.05	1.45	0.0413	0.0571
A1	0	0.15	0.0000	0.0059
A2	0.9	1.3	0.0354	0.0512
A3	0.6	0.7	0.0236	0.0276
b	0.25	0.5	0.0098	0.0197
c	0.1	0.25	0.0039	0.0098
D	2.8	3.1	0.1102	0.1220
E	2.6	3.1	0.1023	0.1220
E1	1.5	1.8	0.0591	0.0709
e	0.95(TYP)		0.0374(TYP)	
L	0.25	0.6	0.0098	0.0236
L1	0.59(TYP)		0.0232(TYP)	
theta	0	8°	0.0000	8°
c1	0.2(TYP)		0.0079(TYP)	

- The contents of this document will be updated with the product's improvement without prior notice. Please consult our sales staff before using this document to ensure that you are using the latest version.
- The application circuit examples described in this document are only used to indicate the representative use of the product and do not guarantee the design of mass production.
- Please use this product within the limits stated in this document. We will not be responsible for any damage caused by improper use.
- The products described in this document are not allowed to be used in equipment or devices that affect the human body without the written permission of our company, including but not limited to: health equipment, medical equipment, disaster prevention equipment, fuel control equipment, automobile equipment, aviation equipment and vehicle equipment.
- Although our company has always been committed to improving product quality and reliability, semiconductor products have a certain probability of malfunction or wrong work. To prevent personal injury or property damage caused by such accidents, please pay full attention to safety design, for example: Alternate design, fire protection design, and prevention of wrong action design.
- When exporting this product or this document overseas, you should abide by applicable import and export control laws.
- Copying or reprinting part or all of this document in any form without the permission of our company is strictly prohibited.

## X-ON Electronics

Largest Supplier of Electrical and Electronic Components

*Click to view similar products for [Linear Voltage Regulators](#) category:*

*Click to view products by [Micro One](#) manufacturer:*

Other Similar products are found below :

[LV5684PVD-XH](#) [MCDTSA6-2R](#) [L7815ACV-DG](#) [LV56801P-E](#) [UA7805CKC](#) [714954EB](#) [ZMR500QFTA](#) [BA033LBSG2-TR](#)  
[NCV78M05ABDTRKG](#) [LV5680P-E](#) [L79M05T-E](#) [L78LR05D-MA-E](#) [NCV317MBTG](#) [NTE7227](#) [MP2018GZD-33-P](#) [MP2018GZD-5-P](#)  
[LV5680NPVC-XH](#) [ZTS6538SE](#) [UA78L09CLP](#) [UA78L09CLPR](#) [CAT6221-PPTD-GT3](#) [MC78M09CDTRK](#) [NCV51190MNTAG](#)  
[BL1118CS8TR1833](#) [BL8563CKETR18](#) [BL8077CKETR33](#) [BL9153-33CC3TR](#) [BL9161G-15BADRN](#) [BL9161G-28BADRN](#)  
[BRCO7530MMC](#) [CJ7815B-TFN-ARG](#) [LM317C](#) [GM7333K](#) [GM7350K](#) [XC6206P332MR](#) [HT7533](#) [LM7912S/TR](#) [LT1764S/TR](#) [LM7805T](#)  
[LM338T](#) [LM1117IMP-3.3/TR](#) [HT1117AM-3.3](#) [HT7550S](#) [AMS1117-3.3](#) [HT7150S](#) [78L12](#) [HT7550](#) [HT7533-1](#) [HXY6206I-2.5](#) [HT7133](#)