

High Input Voltage LDO Regulators ME6203 Series

General Description

The ME6203 series are highly accurate, low noise, LDO Voltage Regulators that are manufactured using CMOS technology and the input voltage of ME6203 series is in Excess of 30 V. This series contains three fixed output voltages of 3.0V, 3.3V and 5.0V that have no minimum load requirement to maintain regulation. On chip trimming adjusts the output voltage to within $\pm 2.5\%$ accuracy. ME6203 consists of a output current limiting, a driver transistor, a precision reference voltage and an error amplifier. Output voltage is selectable in 100mV steps between 1.5V ~ 6.0V. The Devices are available in SOT-89(500mW).

Features

- Output Current in Excess of 100mA
- Operating Voltage Range: 7V ~ 30V
- Highly Accuracy: $\pm 2.5\%$
- Small Standby Current: 13 μ A (TPY.)
- Ripple Rejection: 40dB@1KHz (ME6203A33)
- Line Regulation: 0.5% (TYP.)
- Temperature Stability: 0.5% (TYP.)
- Operational Temperature Range: 0 $^{\circ}$ C ~ 100 $^{\circ}$ C
- Small Packages: SOT-89

Selection Guide

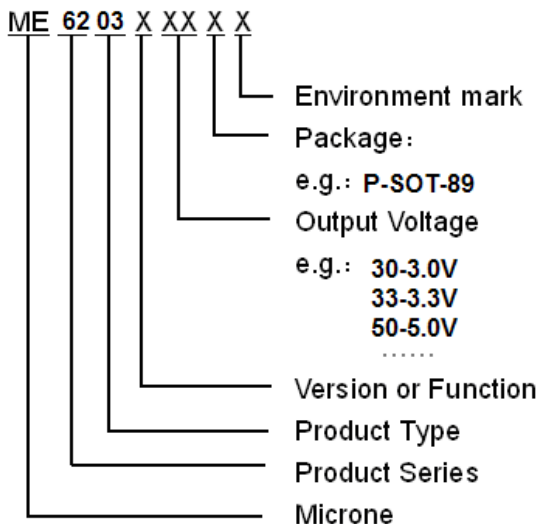

Typical Application

- Consumer and Industrial Equipment Point of Regulation
- Portable AV equipment
- Battery powered equipment
- Cameras, video recorders
- Reference voltage

Typical Application Circuit

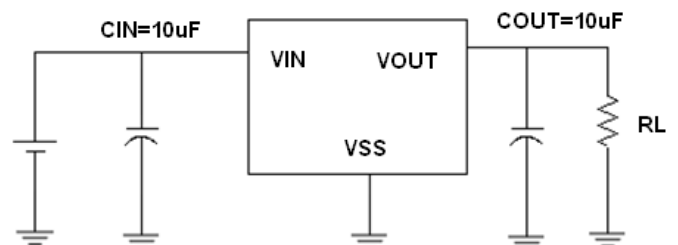

Pin Configuration

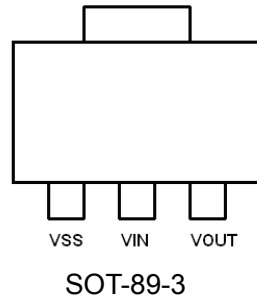

Pin Assignment

ME6203AXX

Pin Number	Pin Name	Functions
1	V _{SS}	Ground
2	V _{IN}	Input
3	V _{OUT}	Output

Block Diagram

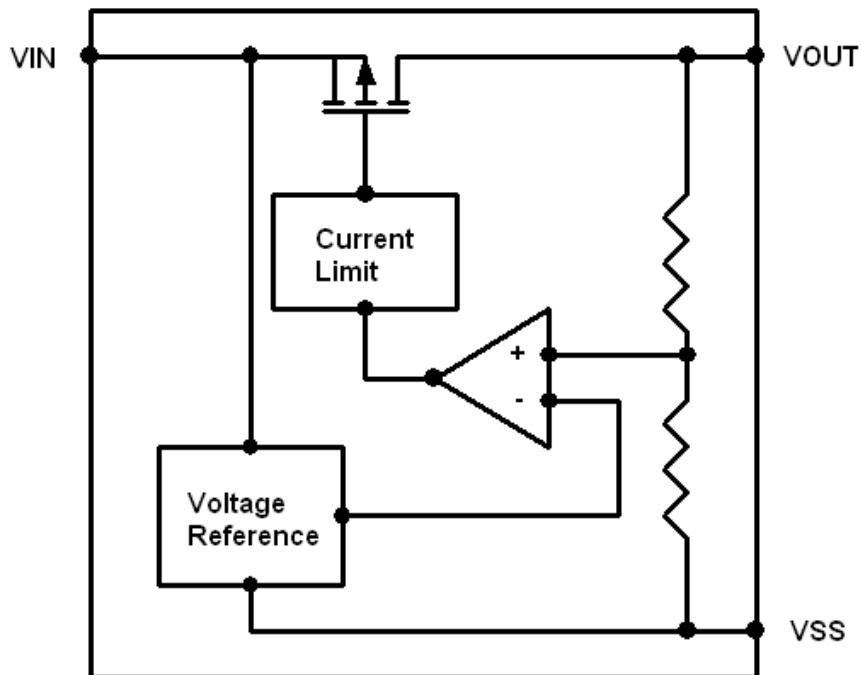

Absolute Maximum Ratings

Parameter	Symbol	Ratings	Units
Input Voltage	V_{IN}	36	V
Output Voltage	V_{OUT}	$V_{SS}-0.3 \sim V_{IN} + 0.3$	V
Power Dissipation	SOT-89 P_D	500	mW
Operating Temperature Range	T_{OPR}	0 ~ +100	°C
Storage Temperature Range	T_{STG}	-40 ~ +150	°C
Lead Temperature	SOT-89	260°C, 10sec	

Electrical Characteristics

ME6203A30

($V_{IN}=7V$, $C_{IN}=C_L=10\mu F$, $T_a=25^\circ C$, unless otherwise noted)

Parameter	Symbol	Conditions	Min.	Typ.	Max.	Units
Output Voltage	$V_{OUT(E)}$ (Note 2)	$I_{OUT}=10mA$, $7V \leq V_{IN} \leq 30V$	X 0.975	$V_{OUT(T)}$ (Note 1)	X 1.025	V
Input Voltage	V_{IN}		7		30	V
Maximum Output Current	I_{OUTMAX}	$V_{IN}=7V$		100		mA
		$V_{IN}=24V$		20		
		$V_{IN}=30V$		15		
Load Regulation	ΔV_{OUT}	$V_{IN}=7V$, $0mA \leq I_{OUT} \leq 100mA$		10	30	mV
Line Regulation	ΔV_{OUT}	$I_{OUT}=10mA$, $7V \leq V_{IN} \leq 30V$		10	35	mV
Temperature Stability	ΔV_{OUT}	$V_{IN}=7V$, $I_{OUT}=10mA$, $0 \sim 100^\circ C$		0.5	1.5	%
Quiescent Current	I_s			13	18	μA
short-circuit current	I_{short}	$V_{IN}=7V$		13	30	mA
Ripple Rejection Rate	PSRR	$V_{IN}=12V+1Vp-pAC$ $I_{OUT}=5mA, 1kHz$		40		dB

ME6203A33

($V_{IN}=7V$, $C_{IN}=C_L=10\mu F$, $T_a=25^{\circ}C$, unless otherwise noted)

Parameter	Symbol	Conditions	Min.	Typ.	Max.	Units
Output Voltage	$V_{OUT(E)}$ (Note 2)	$I_{OUT}=10mA$, $7V \leq V_{IN} \leq 30V$	X 0.975	$V_{OUT(T)}$ (Note 1)	X 1.025	V
Input Voltage	V_{IN}		7		30	V
Maximum Output Current	I_{OUTMAX}	$V_{IN}=7V$		100		mA
		$V_{IN}=24V$		20		
		$V_{IN}=30V$		15		
Load Regulation	ΔV_{OUT}	$V_{IN}=7V$, $0mA \leq I_{OUT} \leq 100mA$		10	30	mV
Line Regulation	ΔV_{OUT}	$I_{OUT}=10mA$, $7V \leq V_{IN} \leq 30V$		10	35	mV
Temperature Stability	ΔV_{OUT}	$V_{IN}=7V$, $I_{OUT}=10mA$, $0 \sim 100^{\circ}C$		0.5	1.5	%
Quiescent Current	I_s			13	18	μA
short-circuit current	I_{short}	$V_{IN}=7V$		13	30	mA
Ripple Rejection Rate	PSRR	$V_{IN}=12V+1Vp-pAC$ $I_{OUT}=5mA, 1kHz$		40		dB

ME6203A50

($V_{IN}=7V$, $C_{IN}=C_L=10\mu F$, $T_a=25^{\circ}C$, unless otherwise noted)

Parameter	Symbol	Conditions	Min.	Typ.	Max.	Units
Output Voltage	$V_{OUT(E)}$ (Note 2)	$I_{OUT}=10mA$, $7V \leq V_{IN} \leq 30V$	X 0.975	$V_{OUT(T)}$ (Note 1)	X 1.025	V
Input Voltage	V_{IN}		7		30	V
Maximum Output Current	I_{OUTMAX}	$V_{IN}=7V$		100		mA
		$V_{IN}=24V$		20		
		$V_{IN}=30V$		15		
Load Regulation	ΔV_{OUT}	$V_{IN}=7V$, $0mA \leq I_{OUT} \leq 100mA$		10	40	mV
Line Regulation	ΔV_{OUT}	$I_{OUT}=10mA$, $7V \leq V_{IN} \leq 30V$		10	45	mV
Temperature Stability	ΔV_{OUT}	$V_{IN}=7V$, $I_{OUT}=10mA$, $0 \sim 100^{\circ}C$		0.5	1.5	%
Quiescent Current	I_s			15	18	μA
short-circuit current	I_{short}	$V_{IN}=7V$		15	30	mA
Ripple Rejection Rate	PSRR	$V_{IN}=12V+1Vp-pAC$ $I_{OUT}=5mA, 1kHz$		40		dB

Note :

1. $V_{OUT(T)}$: Specified Output Voltage
2. $V_{OUT(E)}$: Effective Output Voltage

Type Characteristics

- (1) Output Voltage VS. Input Voltage
($I_{OUT}=10mA$, $T_a = 25\text{ }^\circ\text{C}$)

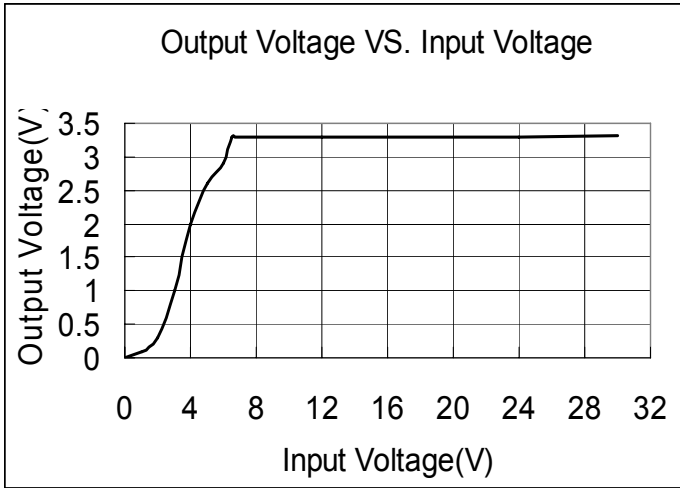

- (2) Output Voltage Change vs. Temperature
($V_{IN}=7V$, $I_{OUT}=10mA$)

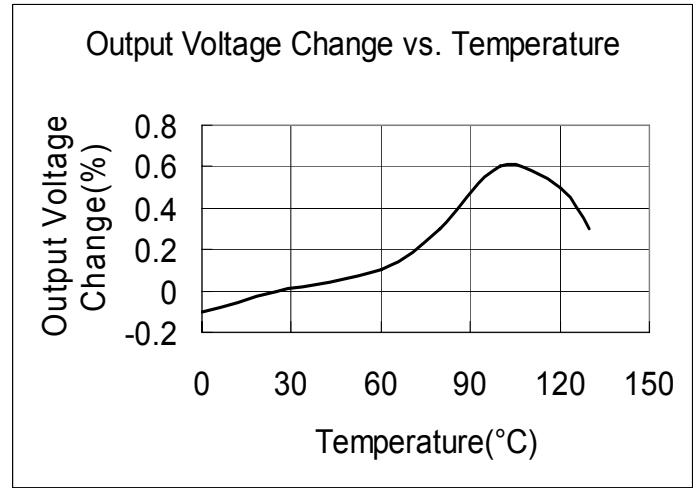

- (3) Output Voltage VS. Output Current
($V_{IN}=7V$, $T_a = 25\text{ }^\circ\text{C}$)

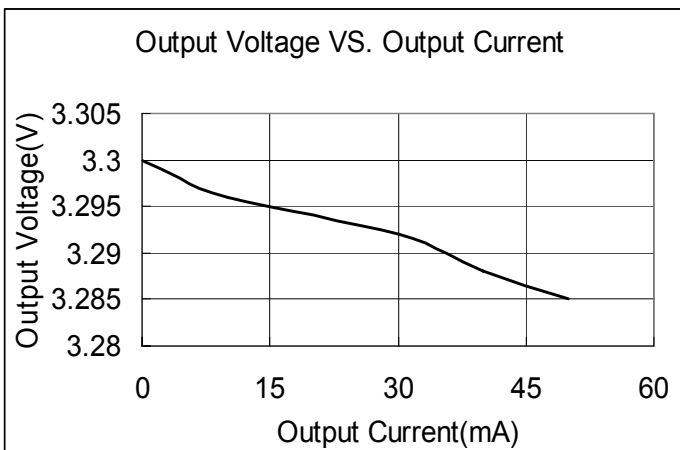

- (4) Ripple Rejection vs. Frequency
($V_{IN} = 12V + 1Vp-pAC$, $I_{OUT}=5mA$, $T_a = 25\text{ }^\circ\text{C}$)

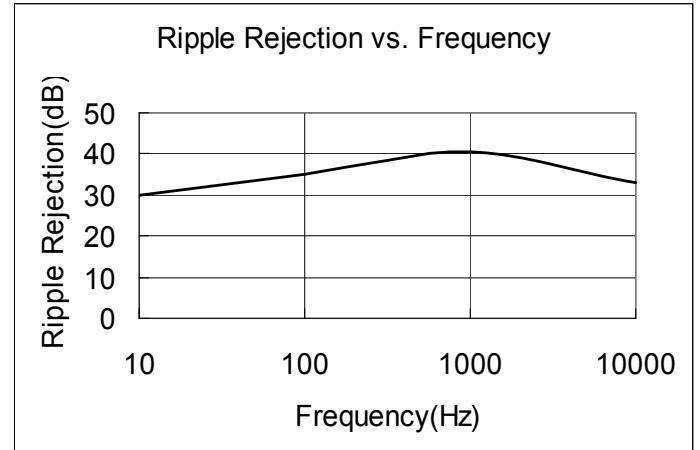

(5) Line Transient Response

ME6203A33

Ch1: Output Voltage Ch2: Input Voltage

$V_{IN}=30V, I_{OUT}=0mA, T_a = 25^\circ C$

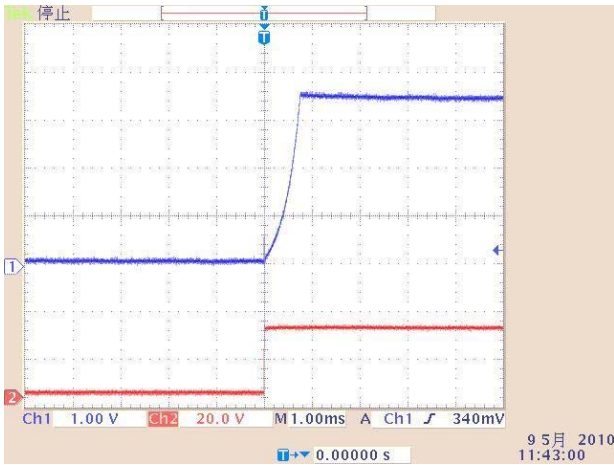

(6) rectangle wave Transient Response

ME6203A33

Ch1: Output Voltage Ch2: Input Voltage

$V_{IN}:0V\sim 20V, T_a = 25^\circ C$

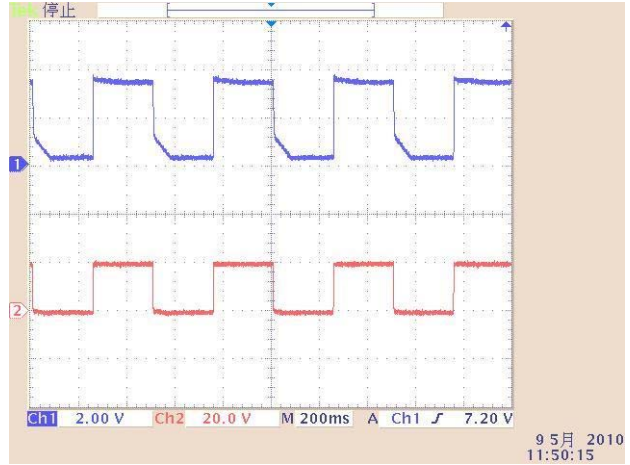

$V_{IN}:10V\sim 30V, T_a = 25^\circ C$

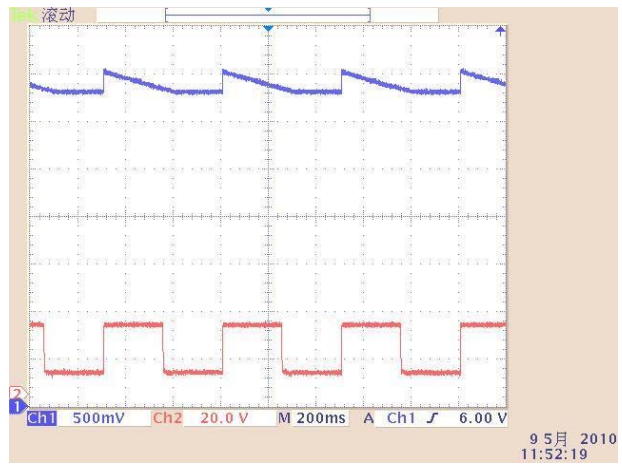

Packaging Information:

SOT-89-3

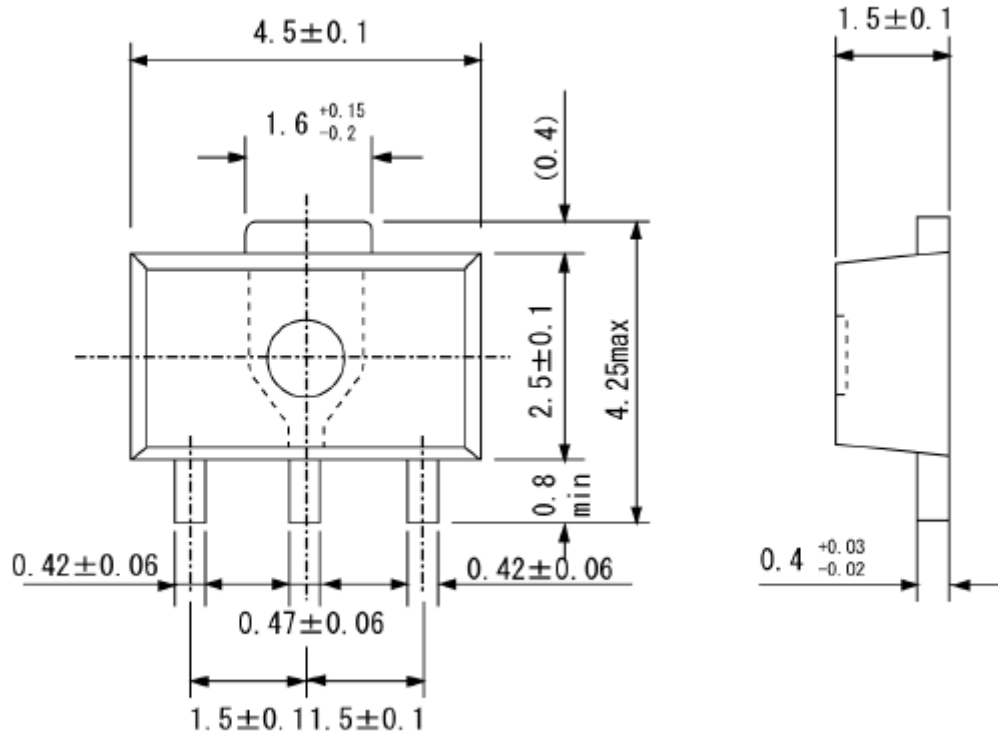

- The information described herein is subject to change without notice.
- Nanjing Micro One Electronics Inc is not responsible for any problems caused by circuits or diagrams described herein whose related industrial properties, patents, or other rights belong to third parties. The application circuit examples explain typical applications of the products, and do not guarantee the success of any specific mass-production design.
- Use of the information described herein for other purposes and/or reproduction or copying without the express permission of Nanjing Micro One Electronics Inc is strictly prohibited.
- The products described herein cannot be used as part of any device or equipment affecting the human body, such as exercise equipment, medical equipment, security systems, gas equipment, or any apparatus installed in airplanes and other vehicles, without prior written permission of Nanjing Micro One Electronics Inc.
- Although Nanjing Micro One Electronics Inc exerts the greatest possible effort to ensure high quality and reliability, the failure or malfunction of semiconductor products may occur. The user of these products should therefore give thorough consideration to safety design, including redundancy, fire-prevention measures, and malfunction prevention, to prevent any accidents, fires, or community damage that may ensue.

X-ON Electronics

Largest Supplier of Electrical and Electronic Components

Click to view similar products for [LDO Voltage Regulators](#) category:

Click to view products by [Micro One](#) manufacturer:

Other Similar products are found below :

[AP7363-SP-13](#) [L79M05TL-E](#) [AP7362-HA-7](#) [PT7M8202B12TA5EX](#) [TCR3DF185,LM\(CT](#) [TCR3DF45,LM\(CT](#) [TLE4473G V52](#) [059985X](#)
[NCP4687DH15T1G](#) [701326R](#) [NCV8170AXV250T2G](#) [AP7315-25W5-7](#) [AP2111H-1.2TRG1](#) [ZLDO1117QK50TC](#) [AZ1117ID-ADJTRG1](#)
[TCR3DG12,LF](#) [MIC5514-3.3YMT-T5](#) [SCD7912BTG](#) [NCP154MX180270TAG](#) [SCD33269T-5.0G](#) [NCV8170BXV330T2G](#)
[NCV8170BMX330TCG](#) [NCV8170AMX120TCG](#) [NCP706ABMX300TAG](#) [NCP153MX330180TCG](#) [NCP114BMX075TCG](#) [MC33269T-3.5G](#)
[CAT6243-ADJCMT5T](#) [TCR3DG33,LF](#) [TCR4DG35,LF](#) [TAR5S15U\(TE85L,F\)](#) [TAR5S18U\(TE85L,F\)](#) [TCR3UG19A,LF](#) [TCR4DG105,LF](#)
[MPQ2013AGG-5-P](#) [NCV8170AMX360TCG](#) [TLE4268GSXUMA2](#) [NCP715SQ15T2G](#) [MIC5317-3.0YD5-T5](#) [NCV563SQ18T1G](#)
[NCP715MX30TBG](#) [NCV8702MX25TCG](#) [NCV8170BXV120T2G](#) [MIC5317-1.2YD5-T5](#) [NCV8170AMX150TCG](#) [NCV8170BMX150TCG](#)
[AP2213D-3.3TRG1](#) [NCV8170BMX120TCG](#) [NCV8170BMX310TCG](#) [NCV8170BMX360TCG](#)